



# **KNIGHT**

## **MECHANICAL DRIVE TRUCK PARTS MANUAL PRO TWIN SLINGER MODELS 8118, 8124**

### TABLE OF CONTENTS

Abbreviations .....	2
Using This Listing .....	3
Front Drive Parts .....	4-6
Hydraulic Pump Parts .....	7
Discharge Parts .....	8-9
Rear Drive Parts .....	10-11
Auger & Splash Guard Parts .....	12-13
PTO Driveline 2:1 Gearbox only .....	14-15
2:1 Drive parts .....	16
Right Angle Drive parts .....	17
2:1 Gearbox parts .....	18-19
Right Angle Gearbox parts .....	20-21
Truck Frame Mounting Parts .....	22
Fender and Mounting Parts .....	23
Lid Parts .....	24-25
Decal & Paint List .....	26
Hardware Listing .....	27-28
Part Number Index .....	29-30

Catalog Part Number 006020      Unit Serial Number \_\_\_\_\_

Operator Instruction Manual for this unit: 006017

**ABBREVIATIONS**

Assy	Assembly
A/R	As Required
B	Bolt
Brg	Bearing
BSN	Before Serial Number
Btm	Bottom
C-Bolt	Carriage Bolt
Cttr	Cotter
CV	Constant Velocity
Deg	Degree
Dia	Diameter
ea	Each
eq or Equiv	Equivalent
Fln	Flanged Lock Nut
Fw	Flat Washer
Ga	Gauge
Gr or Grd	Grade
Hd	Head
Hfw	Heavy Flat Washer
Hyd	Hydraulic
ID	Inside Diameter
Ill or Illus	Illustration
Ind	Indicator
Jn	Jam Nut
Kw	Keyway
LH	Left Hand
Ln	Lock Nut
Lw	Lock Washer
Mtg Hrd	Mounting Hardware
NC	National Coarse
NF	National Fine
NLA	No Longer Available
NPT	National Pipe Thread
OD	Outside Diameter
Pc(s)	Piece(s)
PD	Pitch Diameter
PTO	Power Takeoff (shaft)
Qty	Quantity
RH	Right Hand
SN	Serial Number
SHCS	Socket Head Cap Screw
Spk, or Spkt or Sprkt	Sprocket
Sq	Square
SS	Stainless Steel
SSB	Stainless Steel Bolt
St	Straight
Std	Standard
STS	Self Tapping Screw
UASN	Used After Serial Number
UBSN	Used Before Serial Number
W	With
W/O	With Out

## USING THIS SERVICE PARTS LISTING

This listing uses a number indentation system to specify the parts of an assembly. Any number which is indented to the right, indicates that it is a component of the item to the upper left. Example:

<u>Part no</u>	<u>Qty</u>	<u>Description</u>
102-AAA	#	Assembly A
102-BBB	#	Sub-Assembly B
(Component of A)		
140-xxx	#	Sub-Component of B
140-xxx	#	Sub-Component of B
102-CCC	#	Sub-Assembly C
(Component of A)		
etc.		

Using this system, the subassemblies and their components are included if an **Assembly** is ordered. Similarly, the components of a subassemblies are included if a subassembly is ordered.

The quantity (Qty) associated with an assembly, represents the number of times an assembly could be shown in the drawing. The subassembly quantity however, is the number of times a subassembly is used to build one assembly. Similarly, the component quantity refers to the number of times a given component is found in one subassembly.

MODEL AND SERIAL NUMBER INFORMATION is located near the front left hand corner (Fig. A). The model number, serial number and part number should be known when asking service personnel for parts.

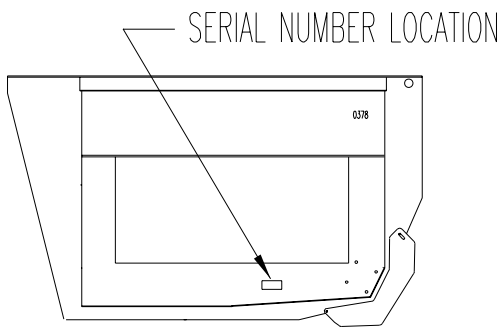

Fig. A

The serial number may consist of a number, or a number with a letter prefix. When referring to serial number breaks in the text of this manual, a serial number with a prefix will have been manufactured after a serial number without a prefix (A001 made after 0123). Likewise, a higher prefix letter would indicate manufacture after a lower prefix letter (B001 made after A123). Therefore, if the text refers to units manufactured after serial number B123, this would include "B" series numbers greater than 123, and all numbers with a higher letter prefix.

If you cannot find the part you need, be as descriptive as possible when placing an order:

**Sprockets:** give the bore size, number of teeth, and size of keyway.

**Roller chain:** give the size of chain (stamped on the side of each link) and number of links.

**Shafting:** give the diameter, length, and quantity and size of keyways.

Hardware is generally not included with parts. If you need any hardware, check the size, the length, and the grade (Fig. B), then check the hardware list in this manual for the part numbers.

**All hex head bolts are grade 5, and nuts are grade 5 unless otherwise stated.**

The hardware listing also includes zerks, cotter pins, set screws, and roller chain links.

**The illustrations in this manual are meant to be used only as a guide for identifying parts and locating their relative positions.**

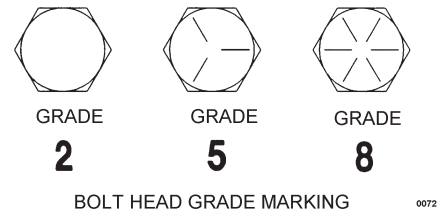
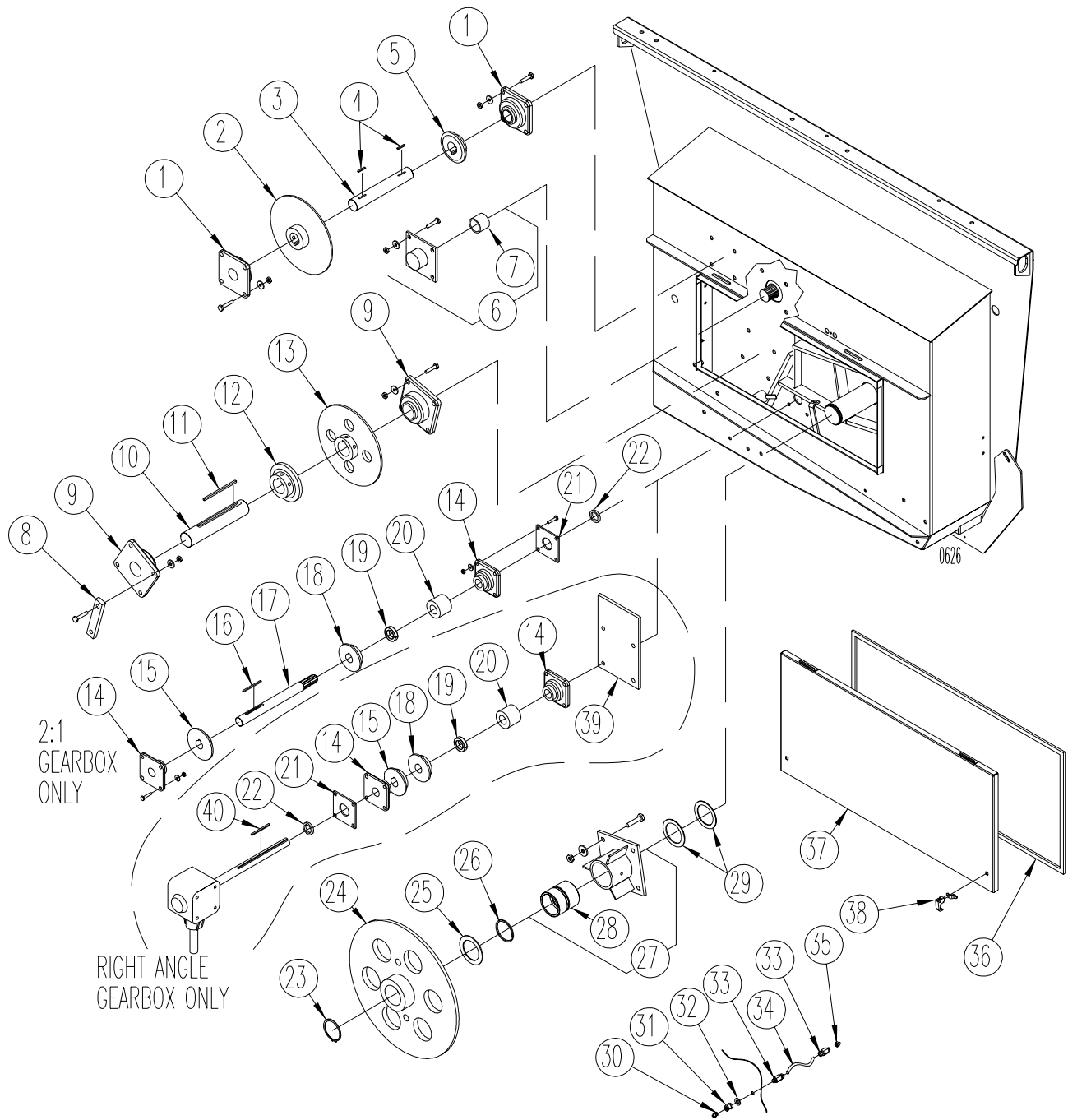

Fig. B

**FRONT DRIVE PARTS**



**FRONT DRIVE PARTS**

REF	PART NO	QTY	DESCRIPTION
1	170-008	2	Bearing, 2" Roller; Mtg Hrd: 5/8" x 1-3/4" Bolt, LW, Nut (4 ea)
2	133-476	1	Sprocket; 60-B-55 x 2" Bore, Inc. 170-249 set screw
3	134-842	1	Counter Shaft; 2" x 12 1/2"
4	170-835	2	Key; 1/2" Sq. x 1-1/2"
5	135-551	1	Sprocket; 80-B-15 x 2" Bore, Inc. 170151 set screw
6	102-212	1	Bearing Assy 2"; Mtg Hrd: 5/8" x 1 1/4" Bolt (4 ea), FW (8 ea), LN (4ea)
7	135-614	1	Bushing, straight; 3" ID x 2 1/2" O.D.
8	135-540	1	Bearing Standoff Bar
9	170-053	2	Bearing, 2 1/2" Roller; Mtg Hrd: 5/8" x 2 1/2" Bolt ( <b>front brg.</b> ) 5/8" x 1-3/4" Bolt, ( <b>rear brg.</b> ) LW, Nut (4 ea)
10	133-530	1	Counter Shaft; 2-1/2" x 12 3/4"
11	171-769	1	Key; 5/8" Sq. x 4-3/8"
12	130-175	1	Sprocket; 120-B-12 x 2 1/2" Bore, Inc. 170-249 set screw
13	135-541	1	Sprocket; 80-B-42 x 2 1/2" Bore, Inc. 170-249 set screw
14	172-288	2	Bearing, Flanged, 1 1/2" ID; Mtg Hrd: 1/2" x 1 3/4" Bolt, LW, Nut (4ea)
15	134-786	1	Sprocket; 60-B-21 x 1 1/2" Bore
16	172-894	1	Key, 3/8" x 3/8" x 2 3/8"
17	134-918	1	Input Shaft; 1 1/2" x 17"
18	134-602	1	Sprocket; 60-B-18 x 1 1/2" Bore
19	172-287	1	Shaft Collar, 1 1/2" ID
20	134-907	1	Chain Guide, 3" OD x 2 1/2"
21	134-906	1	Seal Retainer
22	172-355	1	Seal, Lip, 1 1/2" ID
23	171-607	1	Snap Ring; 3 1/2"
24	134-792	1	Sprocket; 120-B-48 x 3-1/2" Bore
25	136-286	1	Nylon Thrust Washer 1/8" x 3 1/2" ID
26	172-874	1	Quadring Seal
27	102-215	1	Bearing Housing; Mtg Hrd: 5/8" x 1 1/4" Bolt, FW, Nut (4 ea)
28	135-613	1	Bushing, Straight; 3 1/2" I.D. x 4 1/4" O.D.
29	135-598	2	Thrust Washer
30	170-865	1*	Grease Zerk 1/8" NPT
31	172-024	1*	Coupling
32	170-244	1*	Flat Washer 3/8"
33	172-822	2*	Compression Fitting
34	180-630**		Grease Line Tubing
		21"	Required for rear upper counter shaft bearing
		9"	Required for rear lower counter shaft bearing
		25"	Required for left front auger bearing
		12 "	Required for right front auger bearing
		12"	Required for front upper counter shaft bearing
		19"	Required for front lower counter shaft bearing
		37"	Required for front input shaft bearing
		50"	Required for rear input shaft bearing
		19"	Required for front hammer shaft bearing
35	172-823***	1*	Adapter Fitting
36	171-935	10***	Gasket; Foam Seal
37	104-038	1	Shield; Front Oil Enclosure
38	173-027	2	Lift and Turn latch
39	134-908	1	Cover Plate; Mtg Hrd: (4) 1/2" x 1" Bolt, Lw, Nut

\* Quantity required to complete 1 grease line assy

\*\* Sold by the linear foot.

\*\*\* Not required on all installations.

**FRONT DRIVE PARTS**

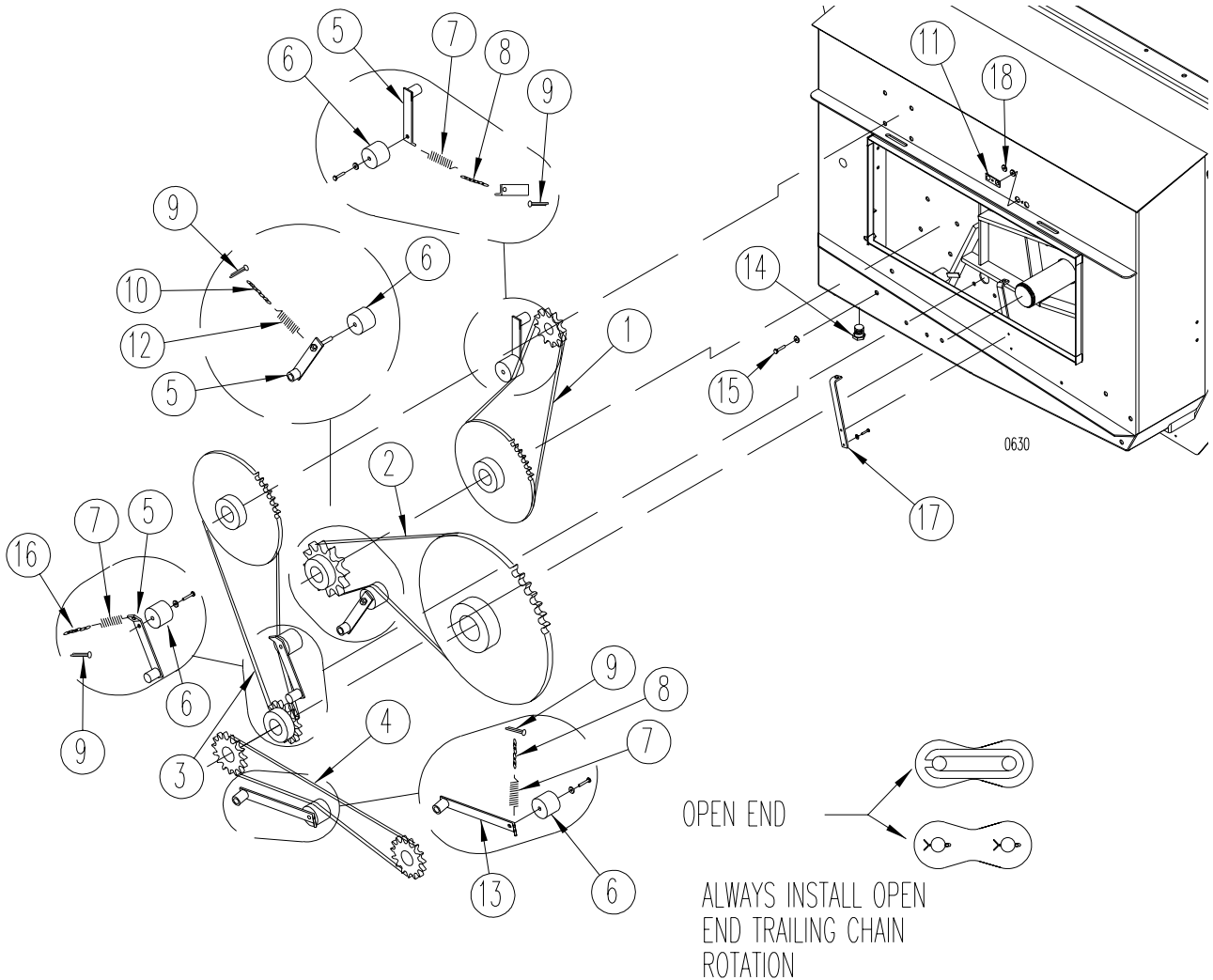

REF	PART NO	QTY	DESCRIPTION
1	172-831	1	Roller Chain; 80-1-86 P
2	172-912	1	Roller Chain; 120-1-68 P
3	172-910	1	Roller Chain; 60-1-124 P
4	172-911	1	Roller Chain; 60-H-124 P
5	101-911	3	Tightener Arm
6	134-155	4	Plastic Tightener Block; Mtg Hrd; 1/2" x 2-3/4" Bolt, FW, LW, Nut (1 ea)
7	172-005	3	Spring, 6" x 1"
8	170-845	2	Machine Chain; #4 x 17 Links
9	170-800	4	Pin, clinch 3/16 x 1 1/2"
10	171-045	1	Machine Chain; #4 x 22 Links
11	135-607	1	Grommet Retainer; Mtg Hrd: 1/4" x 3/4" Bolt, LW, Nut (1 ea)
12	172-751	1	Spring, 8 1/4 x 1 1/2"
13	101-761	1	Tightener Arm
14	171-919	1	Plug: 1 1/4" PVC
15	171-252	1	1/2" x 3/4" Bolt and <b>172-884</b> Washer, Nylon 1/2"
16	170-518	1	Machine Chain; #4 x 30 Links
17	134-889	1	Retainer Arm; Mtg Hrd: 5/16" x 3/4" Bolt, FLN (2 ea)
18	172-876	2	Rubber Grommet

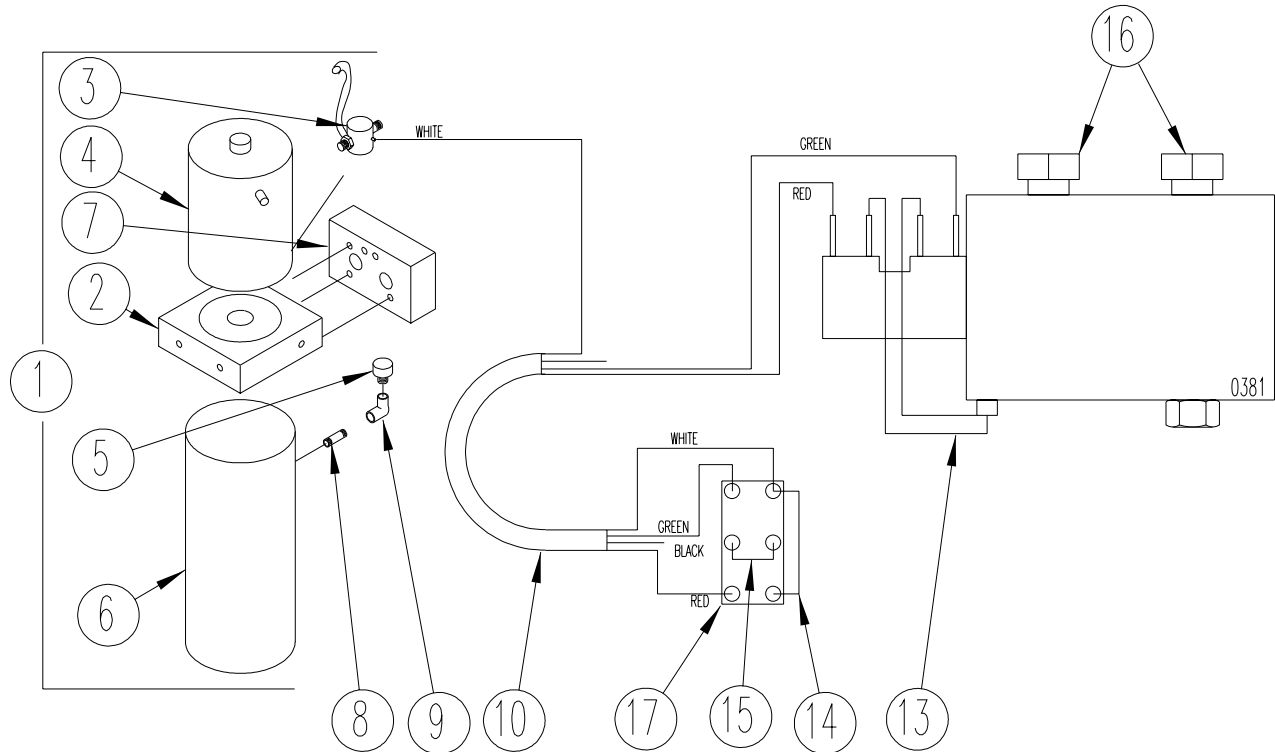
**HYDRAULIC PUMP PARTS**

REF	PART NO	QTY	DESCRIPTION
1	174-529	1	Pump, Hydraulic 12 Volt; Mtg Hrd: 3/8" x 1" Bolt, Lw, Fw (2 ea) Haldex # 1261215
2	174-734	1	Pump, Replacement
3	174-536	1	Solenoid
4	174-535	1	Motor
5	174-537	1	Breather Cap
6	174-735	1	Reservoir
7	174-531		Valve, Manifold Double - For Door and Deflector
	174-532		Valve Manifold, Triple - For Door, Deflector and Hydraulic Lid
	174-534		Switch, Valve Solenoid 12 VDC
	174-533		Valve, Cartridge, 12V 4 Way
8	174-541	1	Nipple, Pipe 3/8" x 2 1/2"
9	174-542	1	Elbow, Pipe 45°, 3/8"
10	103-511	1*	Wire, Control
11	171-062	1	Cable, 2 GA 192", Not Illustrated
12	174-715	2	Eyelet, Connector, Not Illustrated
13	103-510	1*	Wire, Ground
14	103-513	1*	Wire, Jumper
15	172-743	1*	Jumper Strip 2 Conductor
16	173-646	2*	Adapter, Straight 9/16" O.R.B. x 3/8 FM SW
17	171-199	1*	Switch Toggle
18	140-170	1*	Mounted Plate-Switch, Not Illustrated

\* Quantity per valve

For pump replacement parts other than the ones shown contact Haldex for a distributor near you at (815)-398-4400. You will need the pump model number and serial number to order parts.

**DISCHARGE PARTS**

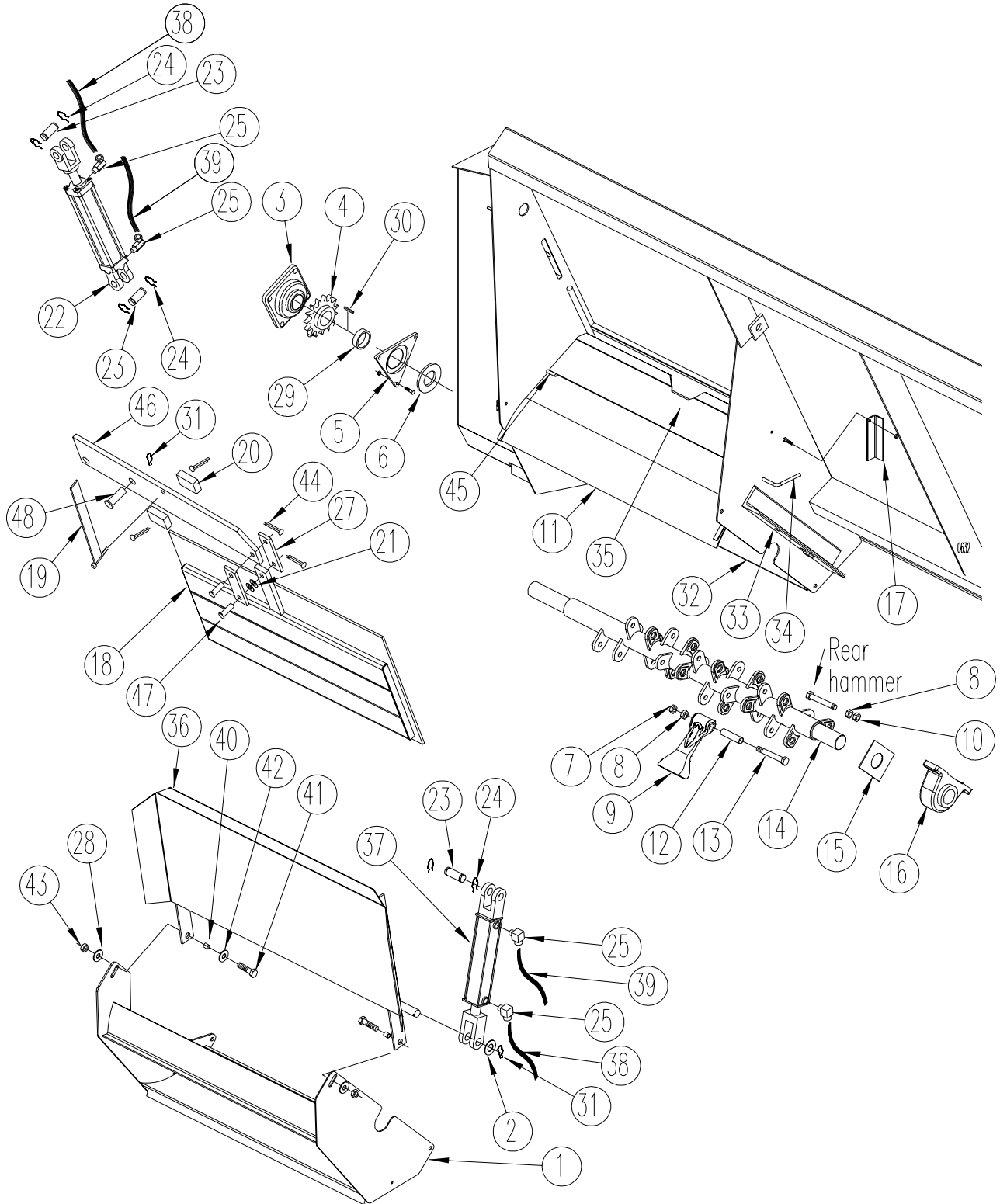



**DISCHARGE PARTS**

REF	PART NO	QTY	DESCRIPTION
1	104-041	1	Discharge Shroud Assy; Mtg Hrd 1/2" x 1 1/4" Bolt, & LN (2 ea) <b>(lower shroud mt. only)</b>
2	170-122	1	Washer, Flat, 1"
3	170-008	1	Bearing; 2" Flanged; Mtg Hrd 5/8" x 1 3/4" LW & Nut (4 ea)
4	134-460	1	Sprocket; 60-B-23, 2" Bore 1/2" KW, Inc. 170151 set screw
5	134-831	1	Seal Retainer Plate; Mtg Hrd: 5/16" x 1" FLN (3 ea)
6	133-277	1	Seal, 2 1/2" ID Plastic
7	170-031	14	Lock Nut; 5/8" <b>(Grade 5)</b>
8	170-037	15	Jam Nut; 5/8" <b>(Grade 5)</b>
9	175-035	15	Hammer
10	172-866	2	Jam Lock Nut; 5/8" (Grade 5)(rear hammer only)
11	134-846	1	Top Door Frame; Weld On
12	172-422	15	Bushing; Straight Nylon
13	172-421	14	Bolt; 5/8" x 5 1/2" Bolt <b>(Grade 5)</b>
	142-003	1	Bolt; 5/8" x 4 3/4" Bolt <b>(Grade 5) (rear hammer only)</b>
14	101-988	1	Hammer Shaft Assy
15	134-875	1	Plastic Shaft Seal; 1/8" x 4" x 5"
16	171-586	1	Pillow Block Bearing 2"; Mtg Hrd; 5/8" x 2 1/2" <b>(172-381)</b> B, FW, JN & LN (2 ea.)
17	134-874	1	Lock Angle; Mtg Hrd: 5/16" x 1" Bolt, Fw, & Nut
18	101-986	1	Discharge Door Assy
19	102-208	1	Door Height Indicator Bar; Mtg Hrd; 1/2", LN
20	172-875	2	Foam Seal; 7/8" x 2" x 3"; Mtg Hrd 170-056 1/4" x 2 cotter pin (1EA)
21	170-066	A/R	Flat Washer; 5/8"
22	173-271	1	Hydraulic Cylinder; 2 1/2" x 8", Order <b>Seal Kit # (170-464)</b>
23	173-274	3	Clevis Pin; 1"
24	173-275	6	Hair Pin Clip
25	171-030	4	Adapter; 3/8" x 90 Degree
26	171-782	1	Double Hose Clamp; Mtg Hrd: 5/16" x 3/4" Bolt, Lw & Nut (not shown)
27	135-608	2	Door Linkage
28	175-299	2	Heavy Washer; 1/2"
29	172-772	1	Lock Collar, 2"
30	170-835	1	Key; 1/2" x 1/2" x 1 1/2"
31	170-074	2	Hair Pin
32	134-649	1	Mount; Bottom 5/16 x 14 1/32 x 38 5/8, Weld On
33	133-288	1	Bearing Mount; RH, Weld On
34	134-902	1	Clean Out Handle; Weld On
35	134-899	1	Clean Out Door; Weld On
36	103-622	1	Deflector Assembly
37	173-273	1	Cylinder; 2" DIA x 10" stroke, (Seal Kit #170-075)
38	171-428	2	Hydraulic Hose; 1/4" x 102" OAL
39	172-042	2	Hydraulic Hose; 1/4" x 111" OAL
40	142-082	2	Bushing
41	170-002	2	Bolt; 1/2" x 1 3/4"
42	171-774	2	Washer; 1/2"
43	170-042	2	Lock Nut; 1/2"
44	170-236	2	Cotter Pin 5/32" x 1 1/2"
45	133-637	1	Cover Hinge; 3/8" x 2", Weld On
46	136-495	1	Pivot Linkage
47	171-696	2	Clevis Pin; 5/8" x 2"
48	170-073	2	Clevis Pin; 1" x 2 1/2"FW, JN & LN (2 ea.)

**REAR DRIVE PARTS**

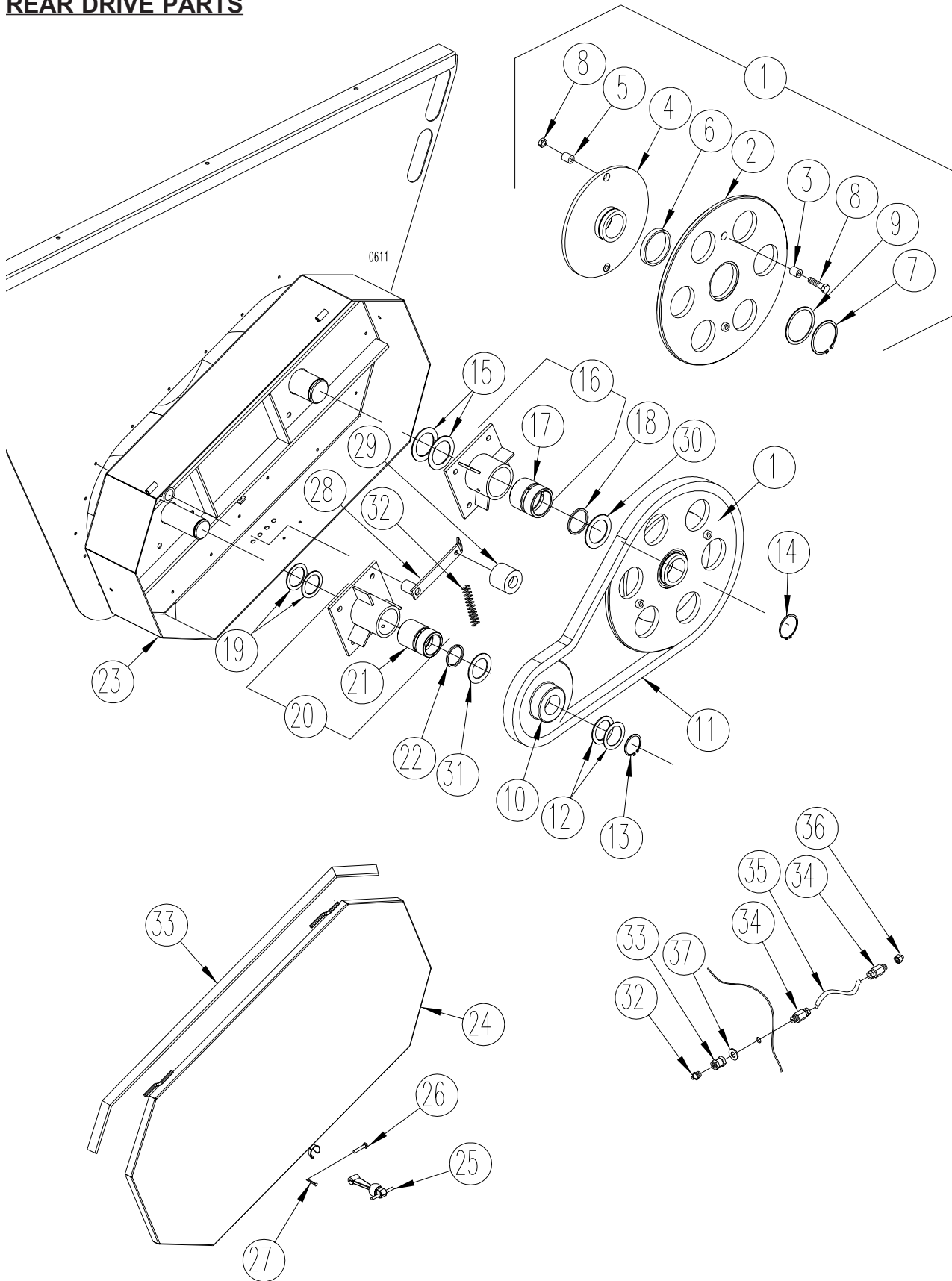

**REAR DRIVE PARTS**

REF	PART NO	QTY	DESCRIPTION
1	102-207	1	Shear Sprocket and Hub Assembly
2	102-226	1	Shear Sprocket Assembly
3	134-893	2	Bushing (weld on)
4	102-225	1	Shear Hub Assembly
5	134-893	2	Bushing (weld on)
6	134-481	1	Bronze Bushing (press fit into hub)
7	171-989	1	Snap Ring; 4" External
8	170-168	2	Shear Bolt; 1/2" x 3" Grade 5; 170-042: Lock Nut, 1/2" Grade 5
9	134-892	1	Retainer Plate
10	135-550	1	Sprocket 100B-24 2 1/2" Splined Bore
11	170-952	1	Roller Chain 100-1-78P
12	172-046	A/R	Spacer Washer 2 1/2" I.D. 14 Gage
	171-968	A/R	Spacer Washer 2 1/2" I.D. 10 Gage
13	170-152	1	Snap Ring; 2 1/2" External
14	171-934	1	Snap Ring; 3" External
15	135-597	2	Thrust Washer, plastic; 3" I.D.
16	102-214	1	Bearing Assembly; 3" Mtg Hrd: 5/8" x 1 1/4" Bolt, LN (4 ea), FW (8 ea)
17	135-612	1	Bushing, Straight 3" I.D. x 3.75 O.D.
18	172-873	1	Quadring Seal; 2 7/8" I.D.
19	135-596	2	Thrust Washer; 2 1/2" I.D.
20	102-213	1	Bearing Assembly; 2-1/2" Mtg Hrd: Mtg Hrd: 5/8" x 1 1/4" B, LN (4 ea), Fw (8 ea)
21	135-611	1	Bushing, Straight; 2-1/2" I.D. x 3.25 O.D.
22	172-872	1	Quadring Seal; 2-3/8" I.D.
23	102-205	1	Rear End Enclosure Assembly; Mtg Hrd; 5/16" x 3/4" Bolt, LW, Nut (22 ea)
24	102-224	1	Rear Shield Assembly
25	170-950	1	Rubber Latch
26	171-137	1	Pin; 1/4" x 1-1/2"
27	170-364	1	Cotter Pin
28	101-911	1	Tightener Arm
29	134-155	1	Tightener Block; Mtg Hrd; 1/2" x 2-3/4" Bolt, LW, Nut (1 ea)
30	136-285	1	Nylon Thrust Washer, 3"
31	136-284	1	Nylon Thrust Washer, 2 1/2"
32	172-751	1	Spring 8 1/2" LG x 1 1/2" O.D.
33	171-935*	5'	Foam Gasket" (4' 7" long)

**GREASE LINES**

32	170-865	1*	Grease Zerk 1/8" NPT
33	172-024	1*	Coupling
34	172-822	2*	Compression Fitting
35	180-630**		Grease Line Tubing
		10"	Required for left rear auger bearing
		10"	Required for right rear auger bearing
36	172-823***	1*	Adapter Fitting
37	170-244	1*	Flat Washer 3/8"

\* Sold by the linear foot.

\*\* Sold by the linear foot

\*\*\* Not Required on all installations

**AUGER & SPLASH GUARD PARTS**

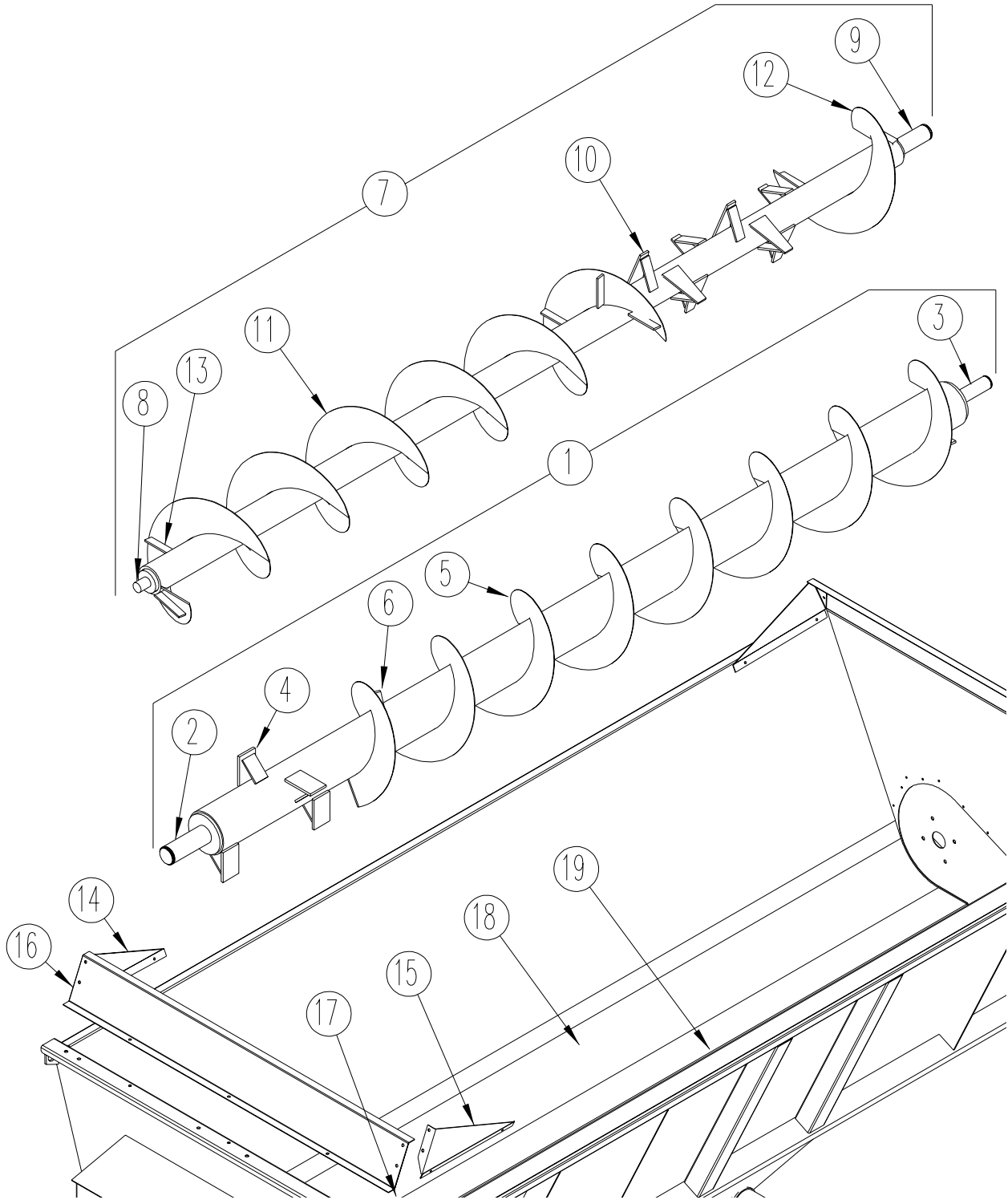

**AUGER & SPLASH GUARD PARTS**

REF	PART NO	QTY	DESCRIPTION
1	102-241	1	Left Auger Assembly
2	102-240	1	Front Plug Assembly; 3 1/2"
3	102-238	1	Rear Plug Assembly; 2 1/2"
4	102-216	6	Paddle Assembly
5	142-031	8	Flighting; 3/8" x 8-5/8" x 20"
6	135-555	6	Flighting Brace
7	102-521	1	Right Auger assembly
8	102-520	1	Front Plug Assembly, 2"
9	102-519	1	Rear Plug Assembly, 3"
10	103-517	8	Paddle Assembly; 5 9/16" Dia Tube
11	142-032	6	Flighting; 3/8" x 5 9/16" x 20"
12	142-035	1	Flighting; 3/8" x 5 9/16" x 20"
13	136-979	8	Flighting Brace; 5 9/16" Dia
14	136-716	1	Splash Guard <b>(RH FT &amp; LH RR)</b> Mtg Hrd; 174-874B, FW (2 ea)
15	136-717	1	Splash Guard <b>(LH FT &amp; RH RR)</b> Mtg Hrd; 174-874B, FW (2 ea)
16	142-028	1	Splash Guard End <b>8124 (FT &amp; RR)</b> Mtg Hrd; 5/16" x 1"B, FW, LW, Nut (7 ea)
	142-027	1	Splash Guard End <b>8118 (FT &amp; RR)</b> Mtg Hrd; 5/16" x 1"B, FW, LW, Nut (7 ea)
17	102-235	1	Shear Shelf (weld on)
19	141-275	A/R	Right hopper repair section 48" (weld on)
20	141-276	A/R	Left hopper repair section 48" (weld on)

**PTO DRIVELINE & FRICTION CLUTCH (2:1 Gearbox only)**

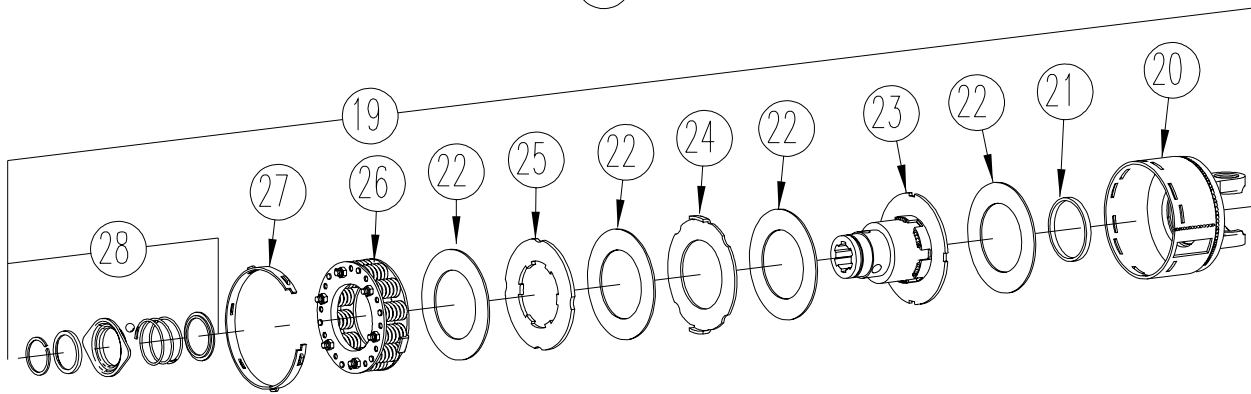
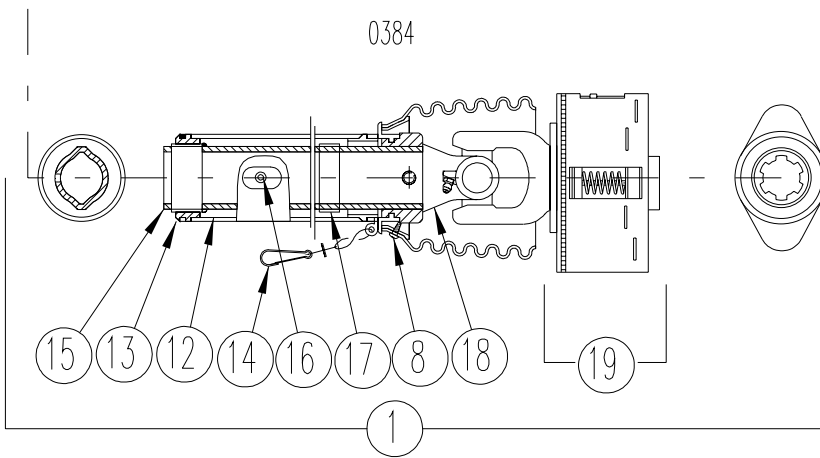
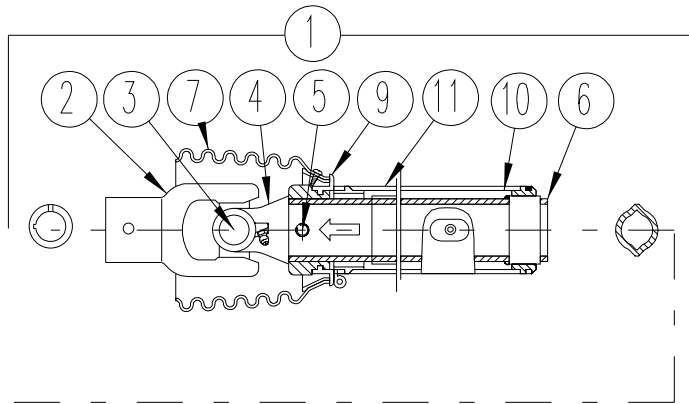

**PTO DRIVELINE & FRICTION CLUTCH (2:1 Gearbox only)**

REF	PART NO	QTY	DESCRIPTION
1	172-774	1	PTO Driveline Assembly
2	172-775	1	6-Spline Yoke & Slide Collar; 1 1/2" Bore Yoke
3	171-980	2	Cross & Bearing Kit
4	172-039	1	Inner Board Yoke
5	171-983	2	Spring Pin
6	171-981	1	Inner Profile Tube
7	172-030	2	Shield Cone
8	172-210	1	Screw
9	171-979	2	Shield Bearing
10	172-032	1	Outer Shield Tube w/Cap
11	171-550	1	Outer Danger Decal
12	172-031	1	Inner Shield Tube w/Cap
13	172-207	1	Support Bearing
14	172-040	1	Safety Chain
15	171-982	1	Outer Profile Tube
16	172-209	1	Zerk
17	171-799	1	Decal, Danger
18	172-033	1	Inboard Yoke
19			Friction Clutch (individual components only)
20	172-037	1	Housing
21	172-038	1	Ring
22	171-977	4	Friction Disc
23	172-036	1	Hub Assembly
24	171-976	1	Drive Plate
25	171-975	1	Drive Plate
26	171-974	1	Spring Pack
27	171-978	1	Setting Ring
28	172-029	1	Flange Quick Detach Kit

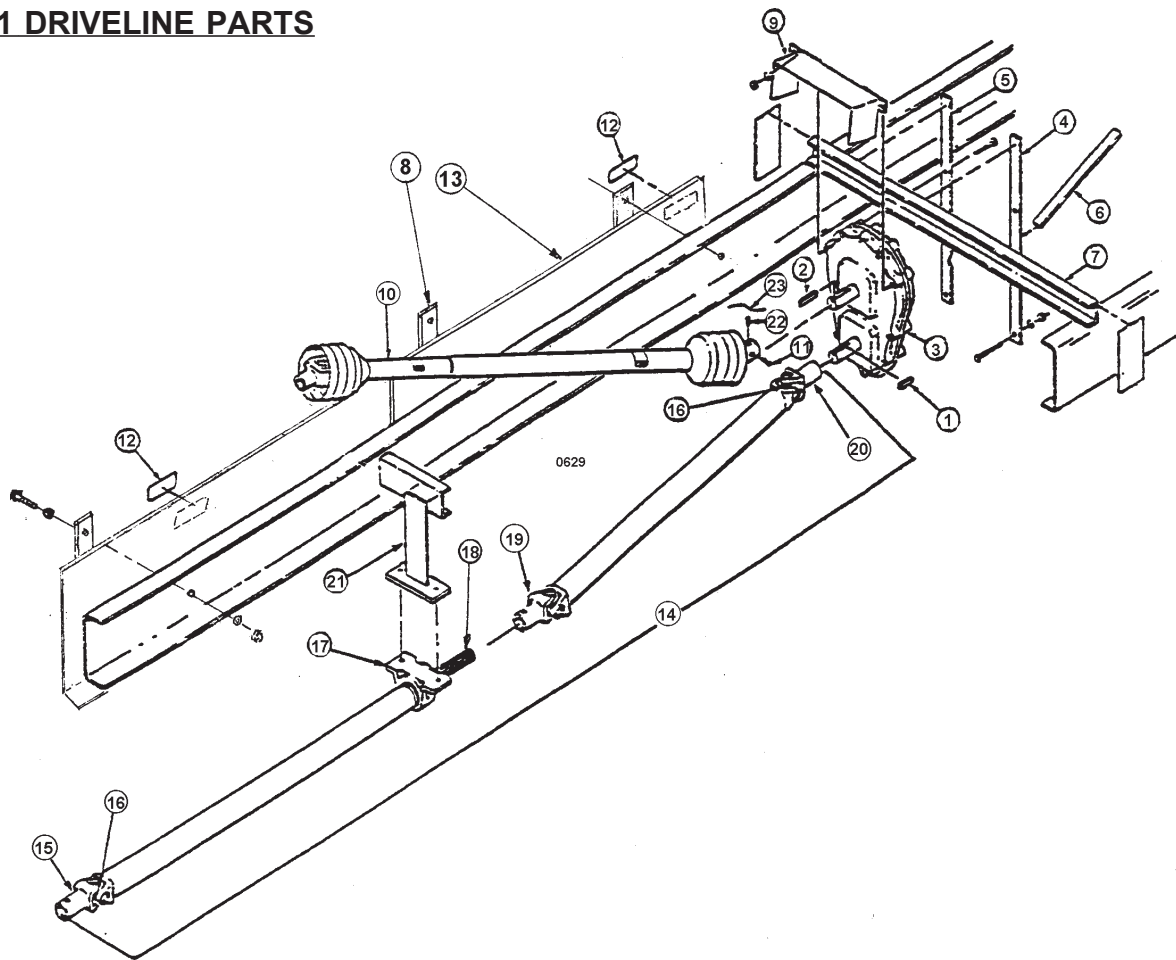
**2:1 DRIVELINE PARTS**

REF	PART NO	QTY	DESCRIPTION
1	170-627	1	Key; 5/16" Sq. x 1 3/4"
2	170-052	1	Key; 3/8" Sq. x 2 1/2"
3	171-384	1	Gearcase
4	133-028	1	Gearcase Mount
5	133-027	1	Gearcase Mount, Notched
6	133-029	1	Gearcase Mount
7	131-845	1	3" x 34" Channel
8	134-969	4	Shield Mount Bracket
9	102-070	1	Gearcase Shield
10	172-774	1	Driveline
11	170-151	1	Set Screw
12	172-786	2	Warning Decal
13	134-970	2	Sheet; Shield
14	172-896	1	PTO Driveline, Complete (Specify length when ordering complete drivelines)
15	172-899	1	Yoke 1 1/4" x 5/16" Keyway
16	172-901	2	Journal and Bearing Kit
17	172-902	1	Center Bearing Assembly
18	172-904	1	Mid-ship Stubshaft
19	172-905	1	Slip Yoke
20	172-900	1	Yoke 1 3/8" x 5/16" Keyway, Mtg hrd: 174-307 U-bolt
21	102-236	1	Mid-ship Bearing Hanger
22	170-290	3	Set Screw (square HD) 3/8 x 3/4
23	172-780	1	Lock Wire

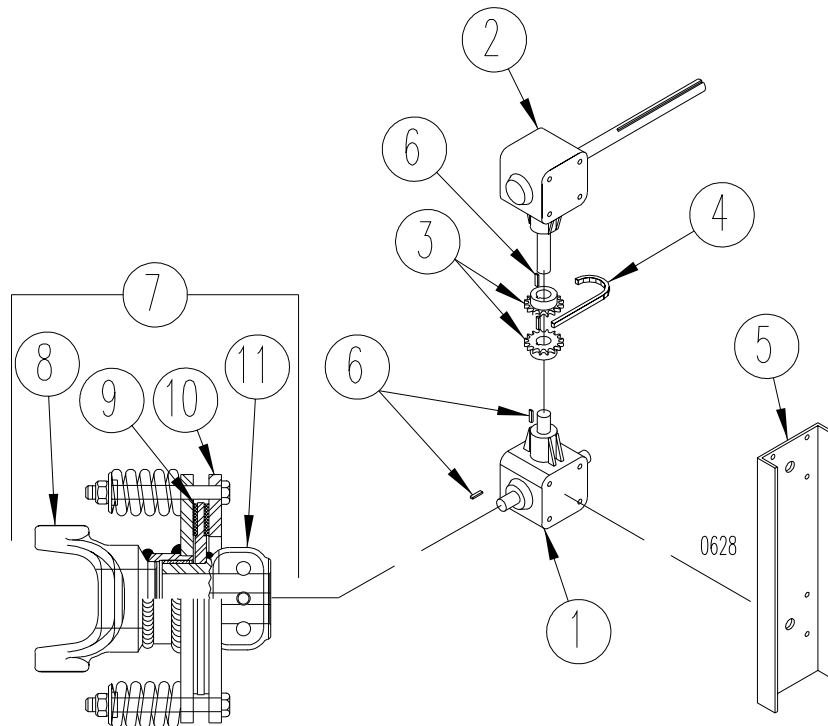

**RIGHT ANGLE DRIVE**

REF	PART NO	QTY	DESCRIPTION
1	173-046	1	Gearcase Assy, 1.35:1
2	173-045	1	Gearcase, 1.35:1
3	136-119	2	Sprocket, 50-B-16, 1 3/8"
4	170-316	1	Chain, Roller, 50-2-16 P
5	136-174	1	Gearcase Mount
6	170-627	3	Key, 5/16" x 5/16" x 1 3/4"
7	173-047	1	Friction Clutch
8	175-133	1	Yoke, hub and plate weldment
9	175-134	1	Friction Clutch repair kit
10	171-759	1	Pressure plate
11	175-135	1	Hub weldment

**2:1 GEARBOX**

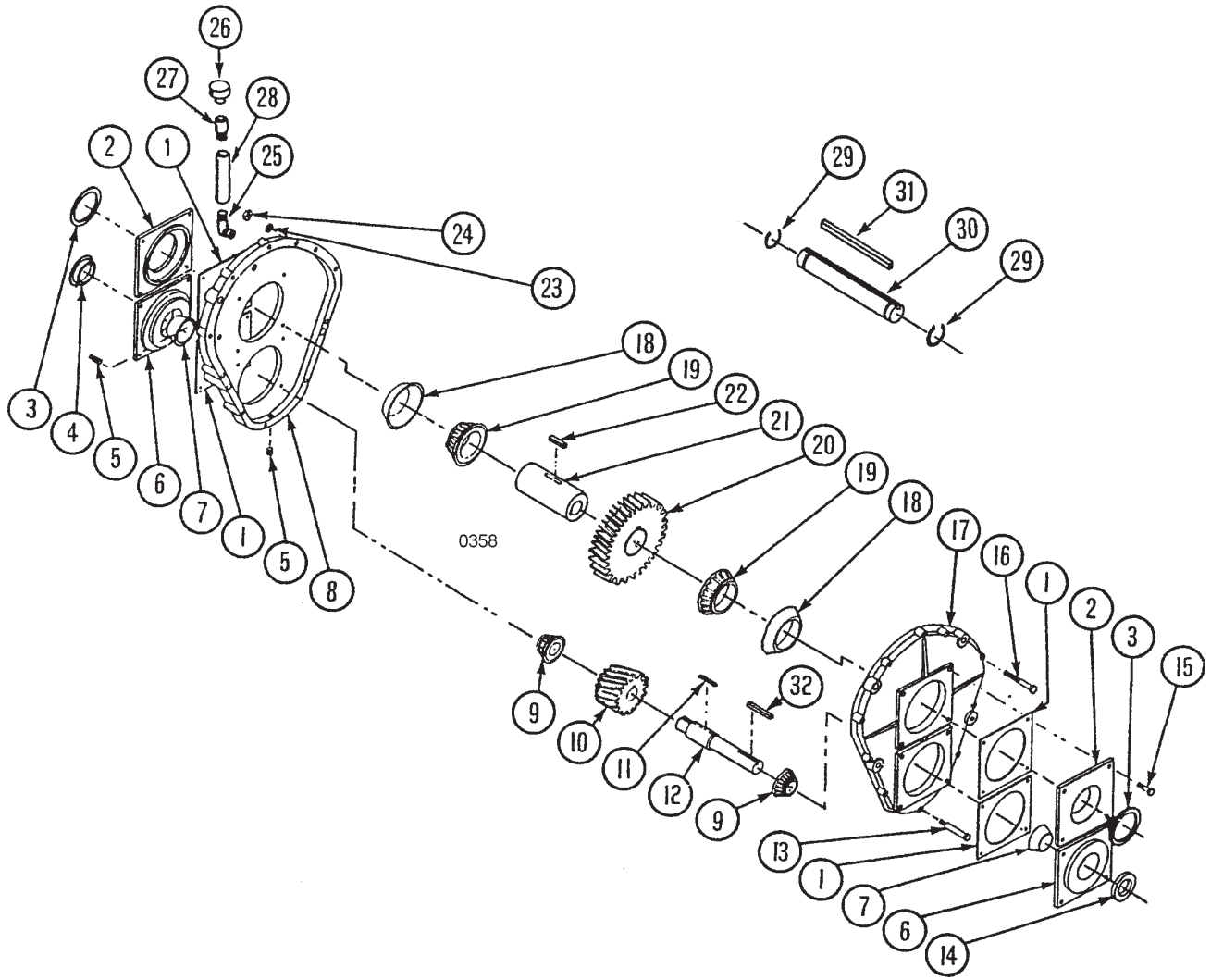

**2:1 GEARBOX**

REF	PART NO	QTY	DESCRIPTION
	171-384	1	Gearbox Assembly Complete
1	171-646	A/R	Shim
2	171-652	2	Cover
3	171-647	2	Grease Seal C/R 26186
4	171-645	1	Cap
5	170-579	2	Plug, 3/8" NPT
6	171-651	2	Cover
7	171-637	2	Bearing Race HM88610
8	171-650	1	Rear Housing
9	171-638	2	Bearing Cone HM88648
10	171-633	1	Pinion Gear
11	171-642	1	Key; 5/16" x 1 5/8"
12	171-641	1	Input Shaft w/ 1 3/8" Keyway
13	171-640	2	Shoulder Bolt; 3/8" x 2 3/4"
14	171-644	1	Grease Seal
15	170-027	16	Bolt; 5/16" x 1"
16	171-639	8	Bolt; 5/16" x 3 1/4" Grade 5
17	171-649	1	Front Housing
18	171-635	2	Bearing Race Timken 394A
19	171-636	2	Bearing Cone Timken 394A
20	171-634	1	Gear; 7 PD, 48 Teeth
21	171-648	1	Output Sleeve
22	171-643	1	Key; 1/2" x 1 1/4"
23	170-118	10	Lock Washer; 5/16"
24	170-119	10	Nut; 5/16" Grade 5
25	171-567	1	Elbow; 3/8" NPT
26	171-568	1	3/8" Breather
27	171-849	1	Coupling; 3/8"
28	171-848	1	Nipple; 3/8"
29	171-387	2	Snap Ring
30	134-922	1	1 1/2' x 7 1/2" Output Shaft
31	172-776	1	Key; 3/8" x 4 3/4"
32	170-627	1	Input Shaft Key; 5/16" x 1 3/4"

**RIGHT ANGLE GEARBOX (2 SHAFT)**

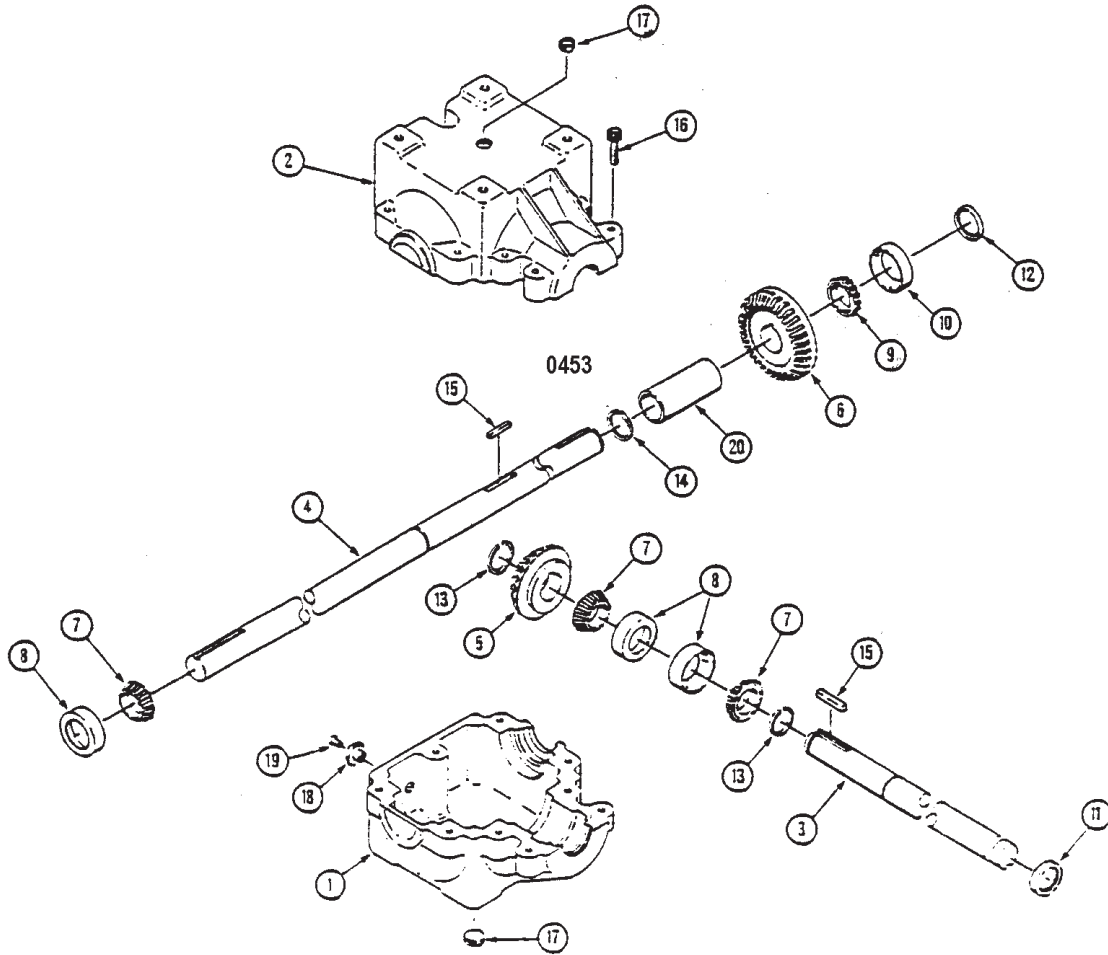

REF	PART NO	QTY	DESCRIPTION
	173-045	1	Gear Box Assembly Complete
1	173-121	1	Casting
2	173-122	1	Casting
3	173-135	1	Shaft; Pinion 1 3/8" X 14.52
4	173-136	1	Shaft; Cross 1 3/8 X 21.29
5	173-127	1	Gear; Superior # 531017
6	173-128	1	Gear; Superior # 531023
7	170-545	3	Bearing Cone (Timken p/n 14137A)
8	170-546	3	Bearing Cup ( Timken p/n 14276)
9	170-638	1	Bearing Cone (Timken p/n 13687)
10	170-639	1	Bearing Cup ( Timken p/n 13620)
11	173-141	1	Seal; 1-3/8" x 2" x 5/16" Thk (C/R 13569)
12	173-142	1	Seal; 1-1/2" x 2" x 5/16" Thk
13	173-144	2	Retaining Ring; 1-3/8"(Superior p/n 503413)
14	173-145	1	Retaining Ring; 1-1/2"(Superior p/n 402150)
15	173-147	2	Key; 5/16" Sq x 1-1/4" Lg
16	173-153	9	Bolt; 3/8"-16 x 2-1/4" SHCS
17	173-152	2	Plug; 1/2" NPT SOC.HD
18	173-150	1	Bushing; 1/2" NPT to 1/8" NPT
19	170-679	1	Plug; Pressure Relief
20	173-149	1	Spacer

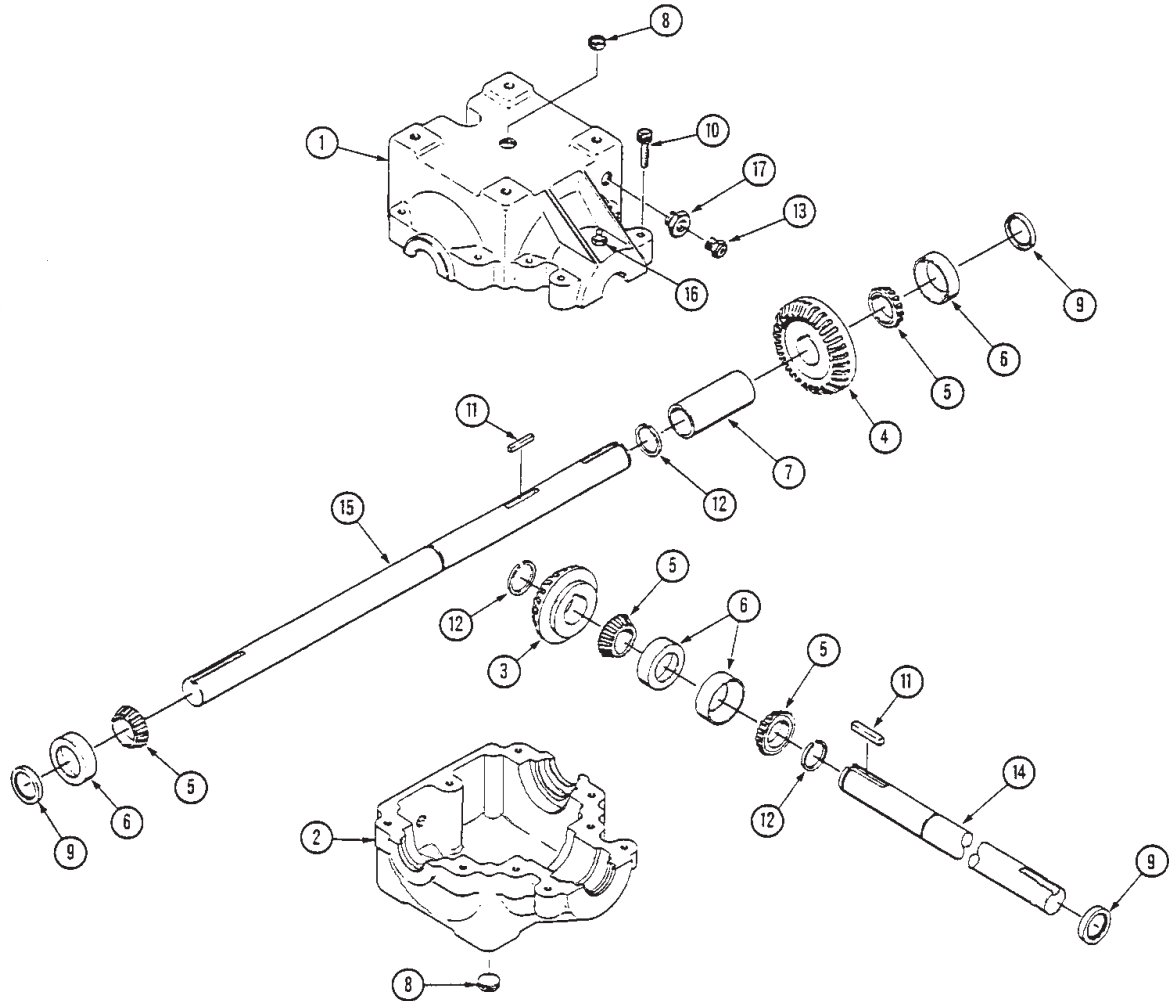
**RIGHT ANGLE GEARBOX ( 3 SHAFT)**

REF	PART NUMBER	QTY	DESCRIPTION
	173-046	1	Gear Box Assembly Complete
1	173-123	1	Casting
2	173-124	1	Casting
3	173-127	1	Gear; Superior # 531017
4	173-128	1	Gear; Superior # 531023
5	170-545	4	Bearing Cone (Timken p/n 14137A)
6	170-546	4	Bearing Cup ( Timken p/n 14276)
7	173-149	1	Spacer
8	173-152	2	Plug; 1/2" NPT SOC.HD
9	173-141	3	Seal; 1-3/8" (C/R 13569)
10	173-153	9	Bolt; 3/8"-16 x 2.25" Lg.
11	173-147	2	Key; 5/16" Sq x 1.2" Lg
12	173-144	3	Retaining Ring; 1-3/8"
13	170-679	1	Plug; Pressure Relief
14	173-137	1	Shaft; Pinion 1 3/8" X 7.52
15	173-138	1	Shaft; Cross 1 3/8" X 13.40
16	173-154	1	Grease Zerk; Spin Drive
17	173-151	1	Bushing; 1/4" NPT to 1/8" NPT

**TRUCK FRAME MOUNTING PARTS**

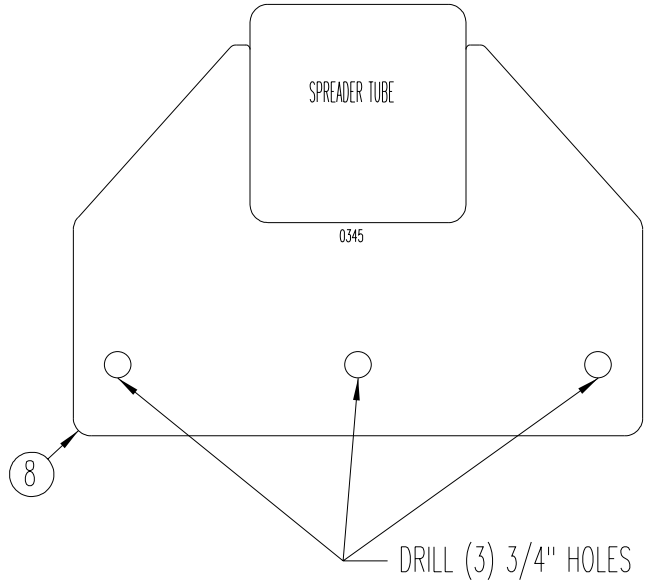
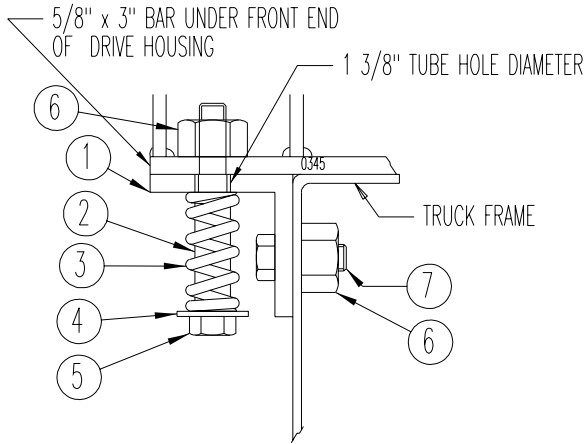

REF	PART NO	QTY	DESCRIPTION
1	136-297	2	Hold down Angle
2	136-298	2	Tube, 1 1/4" x 1/4" x 3 7/16"
3	173-232	2	Compression Spring
4	136-296	2	Washer, 3/8" x 2"
5	173-231	2	Bolt, 3/4" x 6" Grd 8
6	171-900	2	Nut, Lock, 3/4" Grd 8
7	171-877	2	Bolt, 3/4" x 2" Grd 8
8	136-299	2	Rear Truck Mount; Mtg. Hrd: 3/4" x 2" B Grd 8, Ln, Grd 8 (3 ea)

**FENDER & MOUNTING COMPONENTS**

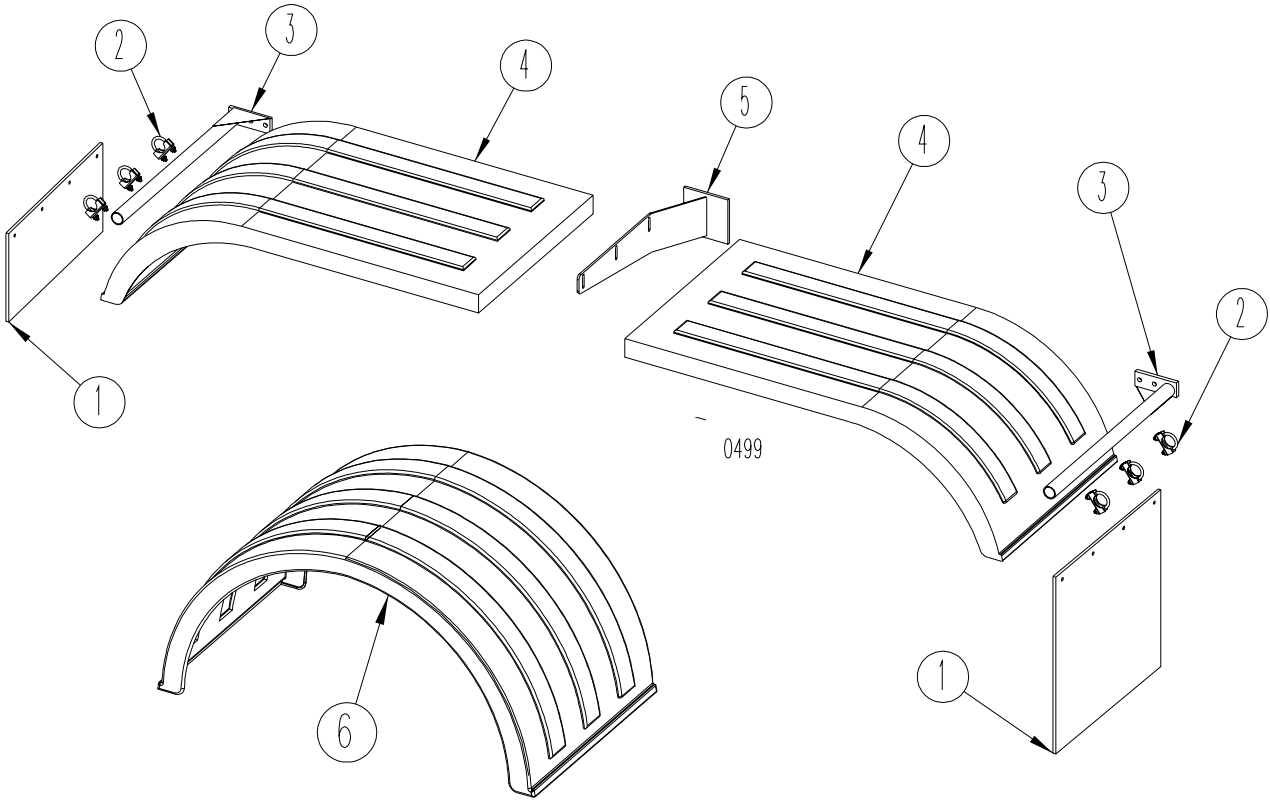

REF	PART NO	QTY	DESCRIPTION
1	173-760	3	Mud Flap; Mtg Hrd: (4) 5/16" x 1"B, (4) 3/8" Hfw, (4) 5/16" Fln (3rd flap is to be cut in half and mounted to the front of fenders)
2	175-204	12	Clamp, 1 1/2" x 5/16" U-bolt, 5/16" Fln (6)
3	103-920	4	Plastic Fender Mount;Mtg Hrd:(3) 5/16" x 1"B, (6) 3/8" HFw, (2) 1/2" x 1 3/4" B, (2) 1/2" Ln, (3) 5/16"Fln
4	175-116	4	Plastic Tandem Axle Fender
5	103-921	2	Plastic Fender Center Mount; Mtg Hrd: (2) 1/2" x 1 3/4" B, (2) 1/2" Ln,(3) 5/16"Fln
6	175-206	2	Plastic Single Axle Fender

**REAR BUMPER**

	PART NO	DESCRIPTION
1	102-905	Bumper Assy

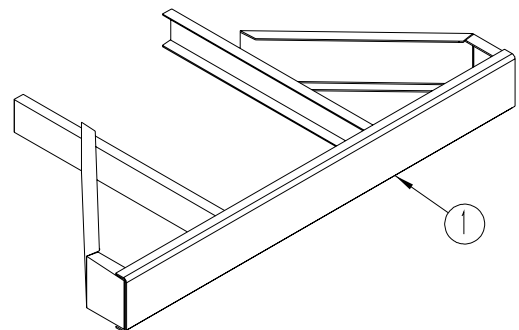

**LID PARTS**

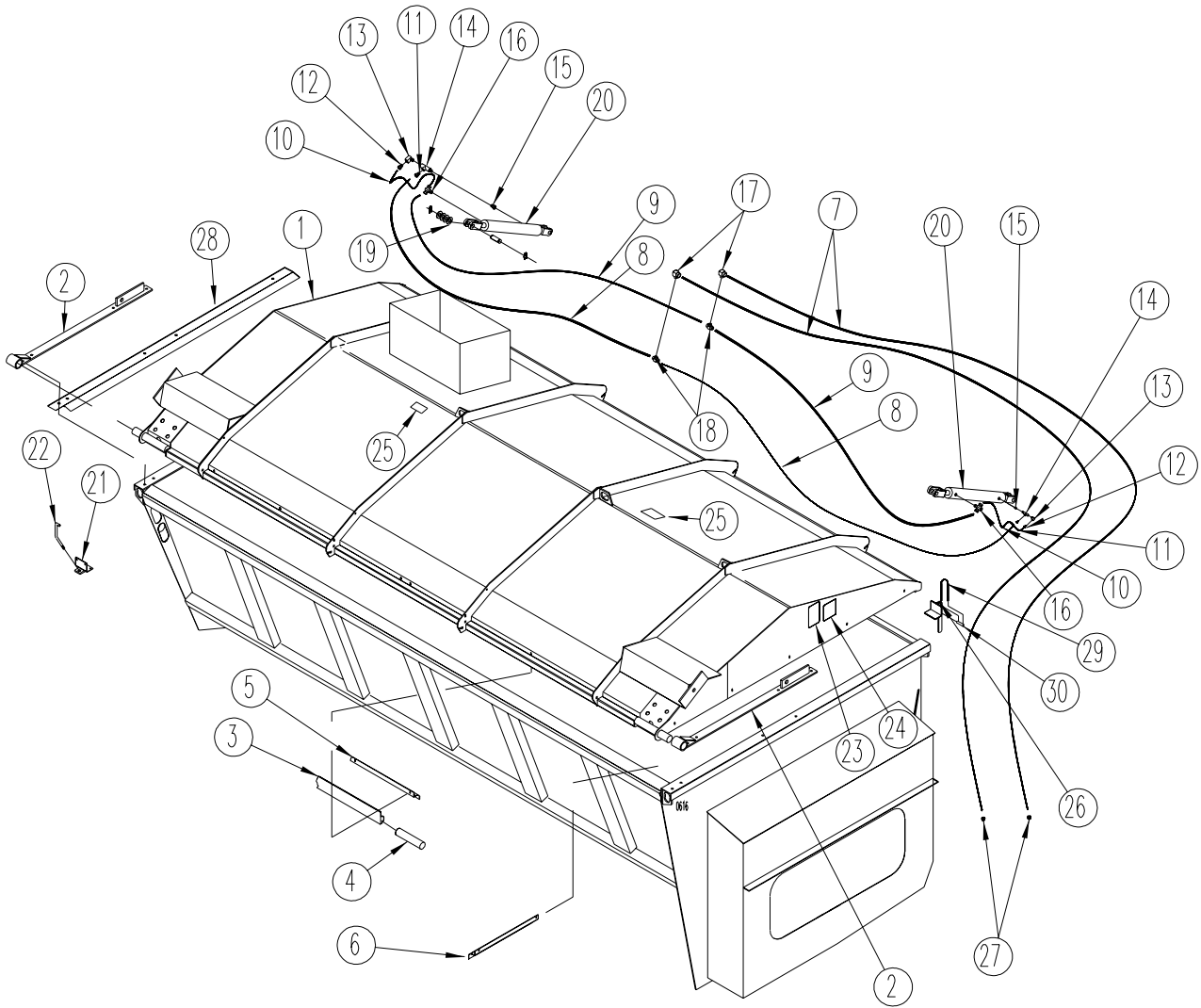



**LID PARTS**

REF	PART NO	QTY	DESCRIPTION
1	104-044	1	Lid Assembly (8118) (Includes Decals)
	104-034	1	Lid Assembly (8124) (Includes Decals)
2	102-073	2	Cylinder Mount - Pivot
3	174-848	50*	Polyester Fabric; Total for Unit
4	174-849	48*	Foam Rubber; 3/8"
5	140-863	4	Seal Retainer; RH&LH Mtg Hrd: 5/16" x 1" Bolt, FW, FLN (5 ea)
6	140-497	2	Seal Retainer (8018); Front and rear, Mtg Hrd: 5/16" x 1" Bolt, FW, LN (4 ea)
	142-023	2	Seal Retainer (8024); Front and rear, Mtg Hrd: 5/16" x 1" Bolt, FW, LN (4 ea)
7	172-793	2	Hydraulic Hose; 1/4" x 252"
8	170-466	2	Hydraulic Hose; 1/4" x 138"
9	171-998	2	Hydraulic Hose; 1/4" x 118"
10	172-794	2	Hydraulic Hose; 1/4" x 20"
11	170-233	2	Swivel Adapter; 3/8" M x 3/8" F SW
12	171-251	2	Swivel Adapter; 1/4" To 3/8" Straight
13	172-809	2	Adapter; 90° Street Elbow, 1/4"
14	172-806	2	Pilot Operated Check Valve
15	172-808	2	Flow Restrictor; 3/8"
16	172-807	2	Swivel Tee Adapter, 3/8" F SW x 3/8"
17	171-030	2	Swivel Adapter; 3/8" M x 3/8" F SW x 90°
18	171-442	2	Tee Adapter; 3/8" (Weld on)
19	170-122	12	Spacer Washers (Approximately 12 Req'd)
20	170-161	2	Hydraulic Cylinder; 2" x 18", (Includes clevis pin & hairpin clip)(Seal Kit 170-075)
21	103-768	2	Hold Down Bracket Mtg Hrd: 1/4" x 1" STS 174-874 (4 ea)
22	140-871	2	Seal Rod; Mtg Hrd: 1/2" FW (2ea), LN, Cotter pin(170-045)(1ea)
23	172-599	2	Decal; Danger Maintain Safe Clearance From Power Lines
24	172-787	2	Decal; Warning Crush Under Top
25	172-821	2	Decal; Caution Do Not Lift Implement Here
26	103-762	2	Hold Down Bracket Mtg Hrd: 1/4" x 1" STS 174-874 (4ea)
27	173-646	2	Reducer Fitting; 9/16"ORB x 3/8" female swivel
28	140-495	1	Seal Retainer (8118 Front) Mtg Hrd: 1/2" x 1 1/2"B,FW(10 ea),LN(5 ea)
	140-496	1	Seal Retainer (8118 Rear) Mtg Hrd:1/2" x 1 1/2"B,FW(10 ea), LN(5 ea)
	142-025	1	Seal Retainer (8124 Front) Mtg Hrd: 1/2" x 1 1/2"B,FW(10 ea),LN(5 ea)
	142-026	1	Seal Retainer (8124 Rear) Mtg Hrd:1/2" x 1 1/2"B,FW(10 ea), LN(5 ea)
29	140-878	2	U- Bolt; Mtg Hrd: 5/16" FLN, (2 ea)
30	140-879	2	Hold Down Pivot Bar
31	171-782	3	Double Hose Clamp; Mtg Hrd: 5/16" x 3/4" Bolt, Lw & Nut (not shown)

\* Sold by Linear Foot

**DECAL & PAINT LIST**

Use the operator's manual for safety decal location.

**Unit Decals:**

<b>PART NO</b>	<b>QTY</b>	<b>DESCRIPTION</b>
175-327	1	Complete Set of Decals <b>(8118)</b>
175-328	1	Complete Set of Decals <b>(8124)</b>
170-490	1	Engage PTO Slowly
170-849	2	Warning...Beware Of Power Driven Parts
171-712	1	Retighten Set Screws
171-799	1	Danger...Do not operate
171-820	4	Danger... Rotating Auger
171-821	2	Danger...Material Discharges
171-913	1	Warning...Do Not Operate
171-915	2	Danger...Shield Missing
172-786	2	Danger...Keep away
174-686	2	Red Reflector
174-687	3	Amber Reflector
172-171	1	Caution...Read Operators Manual
172-759	1	U.S. Patent Decal
175-281	2	"8118"
175-282	2	"8124"
172-820	1	Caution...Lifting Instructions
174-720	2	"KUH N KNIGHT PROTWIN SLINGER"
174-514	1	Kuhn Knight Logo
172-883	1	Oil Level Plug
173-040	1	Caution...PTO Operation

**Lid Decals:**

<b>PART NO</b>	<b>QTY</b>	<b>DESCRIPTION</b>
172-821	1	Decal; Caution - Do Not Lift Here
172-599	1	Decal; Danger - Overhead Wires
172-787	2	Decal; Warning - Crushing Under Top..( <b>Front &amp; Rear</b> )

**Paint:**

170-366 Kuhn Knight Yellow, Aerosol Can  
 170-812 Kuhn Knight Yellow, Quart Can  
 170-813 Kuhn Knight Yellow, Gallon Can

**HARDWARE PART NUMBER LISTING**

All fasteners are NC thread, Grade 5 unless otherwise specified.

**HEX HEAD BOLTS**

Size	Part No		
1/4 x 1/2	173-279	1/2 x 3/4	171-252
1/4 x 3/4	170-803	1/2 x 1	170-149
1/4 x 7/8	171-094	1/2 x 1-1/4	170-373
1/4 x 1	170-310	1/2 x 1-1/2	170-002
1/4 x 1-1/2	170-068	1/2 x 1-1/2 (Grade 8)	172-951
1/4 x 2	172-986	1/2 x 1-3/4	171-774
1/4 x 2 (Grade 8)	175-073	1/2 x 2	171-802
1/4 x 2-3/4	171-203	1/2 x 2-1/4	172-387
1/4 x 3	171-403	1/2 x 2-1/2	170-885
1/4 x 3-1/2	173-640	1/2 x 2-1/2 (Full thread)	171-099
1/4 x 4	173-505	1/2 x 2-3/4	172-007
		1/2 x 3	170-168
		1/2 x 3-1/2	170-167
5/16 x 5/8	170-532	1/2 x 3-1/2 (Grade 8)	172-950
5/16 x 3/4	170-262	1/2 x 4	173-111
5/16 x 3/4 (Stainless steel)	174-787	1/2 x 4 (Full thread)	171-509
5/16 x 7/8	170-256	1/2 x 5	171-412
5/16 x 1	170-027	1/2 x 6	173-506
5/16 x 1-1/4 (Full thread)	170-188	1/2 x 6 (Grade 8)	174-944
5/16 x 1-1/2	170-372	1/2 x 6-1/2	173-711
5/16 x 1-3/4	170-263	1/2 x 7	174-328
5/16 x 2	172-987	1/2 x 7-1/2	175-107
5/16 x 2-1/2	170-369	1/2 x 8-1/2	170-504
5/16 x 3	170-295	1/2 x 11	170-506
5/16 x 3-1/4	171-639		
5/16 x 3-1/2	173-748	9/16 x 1	173-699
5/16 x 4	170-293	9/16 x 1-1/4	173-700
5/16 x 4-1/2	170-294	9/16 x 1-1/2	173-701
5/16 x 5 (Grade 8)	172-983	9/16 x 2	172-219
5/16 x 5-1/2 (Grade 8)	172-952		
		5/8 x 1	171-087
3/8 x 3/4	170-439	5/8 x 1-1/4	171-366
3/8 x 3/4 (Stainless steel)	174-788	5/8 x 1-1/2	170-153
3/8 x 7/8	170-268	5/8 x 1-3/4 (Full thread)	170-030
3/8 x 7/8 (soc. hd.capscrew)	172-044	5/8 x 2	170-009
3/8 x 1	170-054	5/8 x 2 (Full thread)	171-772
3/8 x 1-1/4	170-005	5/8 x 2-1/4	173-009
3/8 x 1-1/4 (Stainless steel)	174-917	5/8 x 2-1/2	172-381
3/8 x 1-1/2	170-368	5/8 x 2-1/2 (Full thread)	170-129
3/8 x 1-3/4	172-383	5/8 x 2-3/4	172-356
3/8 x 2	170-245	5/8 x 3	170-258
3/8 x 2-1/4	170-320	5/8 x 3-1/2	170-038
3/8 x 2-1/2	170-257	5/8 x 4	170-371
3/8 x 2-1/2 (Full thread)	170-128	5/8 x 4-1/2	170-067
3/8 x 2-1/2 (Lag)	171-775	5/8 x 5	170-065
3/8 x 3	170-380	5/8 x 5-1/2	172-421
3/8 x 3-1/2	170-292	5/8 x 6	170-381
3/8 x 4	170-877	5/8 x 6-1/2	173-777
3/8 x 4-1/4 (Black oxide)	171-813	5/8 x 7-1/2	173-019
3/8 x 4-1/2	170-519	5/8 x 9-1/2	171-039
3/8 x 5	170-493		
3/8 x 5-1/2	174-196	3/4 x 1-1/2	173-507
3/8 x 5-1/2 (Full thread)	170-593	3/4 x 2	171-768
3/8 x 6	174-304	3/4 x 2 (Full thread)	170-058
3/8 x 6-1/2	171-291	3/4 x 2 (Grade 8)	171-877
3/8 x 7	172-587	3/4 x 2-1/4	171-275
		3/4 x 2-1/2	170-374
7/16 x 3/4	170-265	3/4 x 2-1/2 (Grade 8)	175-055
7/16 x 1	170-032	3/4 x 3	170-014
7/16 x 1-1/4	170-354	3/4 x 3 UNF	173-776
7/16 x 1-1/4 (Grade 8)	174-216	3/4 x 3-1/2	170-195
7/16 x 1-1/2	170-059	3/4 x 3-1/2 (Grade 8)	171-899
7/16 x 2	170-356	3/4 x 4	170-419
7/16 x 2-1/2	170-379	3/4 x 4 (Grade 8) UNF	173-579
7/16 x 3	170-270	3/4 x 4-1/2	170-846
7/16 x 5-1/2	170-377	3/4 x 4-1/2 (Grade 8)	173-039
7/16 x 6	170-378	3/4 x 4-1/2 (Grade 8) UNF	173-588
		3/4 x 5	173-508
		3/4 x 5 UNF	173-510
		3/4 x 5-1/2 (Grade 8) UNF	173-514
		3/4 x 6	171-116
		3/4 x 6 UNF	173-511
		3/4 x 6 (Grade 8)	173-231
		3/4 x 7	173-745
		3/4 x 7 UNF	173-747
		3/4 x 7-1/2	175-004
		3/4 x 8	173-509
		7/8 x 2-1/4	172-892
		7/8 x 3	172-002
		7/8 x 3-1/2	173-020
		7/8 x 4	173-299
		7/8 x 4 UNF	171-092
		7/8 x 6-1/2	173-774
		7/8 x 7	173-749
		7/8 x 7 UNF	174-097
		7/8 x 8	173-750
		7/8 x 8 UNF	173-515
		1 x 3-1/2	173-021
		1 x 4	175-119
		1 x 4 (Grade 8)	175-248
		1 x 7 UNF	173-516
		1 x 8	174-723
		1 x 8 (grade 8) UNF	173-713
		1-1/4 x 4-1/2 (grade 8)	175-003
		M8 x 16MM (Grade 8.8)	174-610
		M8 x 20MM (Grade 8.8)	175-193
		M8 x 25MM (Grade 8.8)	174-900
		M10 x 22MM (Grade 8.8)	175-016
		M10 x 25MM (Grade 8.8)	173-344
		M12 x 25MM (Grade 8.8)	171-566
		M12 x 35MM (Grade 8.8)	175-020
		M12 x 40MM (Grade 12.9)	175-190
		M12 x 45MM (Grade 10.9)	174-911
		M14 x 30MM (Grade 8.8)	173-518
		<b>CARRIAGE BOLTS</b>	
		1/4 x 1-1/4 (Grade 2)	170-311
		1/4 x 1-1/2 (Grade 2)	170-355
		1/4 x 2 (Grade 2)	170-299
		1/4 x 2-1/2 (Grade 2)	171-394
		1/4 x 2-3/4 (Grade 2)	170-508
		1/4 x 3	170-509
		5/16 x 1 (Grade 2)	170-370
		5/16 x 1-1/2 (Grade 2)	170-296
		5/16 x 2-1/2 (Grade 2)	171-395
		5/16 x 5-1/2 (Grade 2)	170-494
		3/8 x 3-1/2 (Grade 2)	171-283
		3/8 x 4-1/2 (Grade 2)	170-191
		3/8 x 5 (Grade 2)	170-495
		3/8 x 6-1/2 (Grade 2)	171-174
		3/8 x 8 (Grade 2)	170-297
		3/8 x 13 (Grade 2)	170-298
		3/8 x 13-1/2 (Grade 2)	170-300
		1/2 x 1-1/2 (Grade 5)	174-918
		1/2 x 6-1/2 (Grade 2)	171-098
		1/2 x 9 (Grade 2)	171-255
		5/8 x 2	175-110
		5/8 x 2-1/2 (Grade 5)	174-790

KUHN KNIGHT INC.

1501 West 7th Ave. Brodhead, WI 53520-0167

701 Cherry Ave. Greeley, Co. 80632

**HARDWARE PART NUMBER LISTING CONTINUED:****PLOW BOLTS**

5/8 x 2 .....	174-767
3/4 x 2-1/2 .....	174-948

**TRUSS HEAD BOLTS**

#6-32 x 3/4 .....	172-416
#6-32 x 1 .....	173-079
#8-32 x 1-1/2 .....	171-210
#10-32 x 3/4 .....	171-604
#10-32 x 1 .....	172-882
1/4 x 3/4 .....	170-193
1/4 x 1 .....	170-194
5/16 x 1 .....	170-117

**SET SCREWS (Socket Head)(Cup Point)**

1/4 x 1/4 .....	170-247
1/4 x 5/8 .....	172-985
5/16 x 1/4 .....	170-993
5/16 x 5/16 .....	170-248
5/16 x 5/16 UNF .....	170-825
5/16 x 3/8 UNF .....	173-367
5/16 x 1/2 .....	170-254
5/16 x 5/8 UNF .....	170-456
5/16 x 1 (Sq hd) .....	173-610
5/16 x 1-1/2 .....	172-917
3/8 x 1/4 .....	170-856
3/8 x 3/8 .....	170-151
3/8 x 1/2 .....	170-857
3/8 x 1/2 UNF .....	171-469
3/8 x 3/4 .....	174-190
3/8 x 3/4 (Sq hd) .....	170-290
3/8 x 1 .....	170-021
3/8 x 1 (Sq hd) .....	173-609
3/8 x 1 (Sq hd) (Dog pt) .....	171-551
7/16 x 7/16 .....	170-288
7/16 x 1 (Sq hd) .....	170-147
1/2 x 5/8 .....	170-249
1/2 x 1 .....	170-438
1/2 x 1-1/4 (half dog point) .....	171-085
5/8 x 5/8 .....	170-250
3/4 x 3/4 (Sq hd) (Dog pt) .....	170-251

**HEX NUTS**

#6-32 .....	172-418
#10-32 .....	171-606
1/4 .....	170-125
5/16 .....	170-119
3/8 .....	170-007
7/16 .....	170-062
7/16 (Grade 8) UNF .....	174-217
1/2 .....	170-004
9/16 .....	173-702
5/8 .....	170-011
3/4 .....	170-017
3/4 UNF .....	170-159
3/4 (Grade 8) UNF .....	173-520
7/8 .....	171-776
1 .....	173-022
1 UNF .....	173-714
1 (Grade 8) .....	175-247
1 (Grade 8) UNF .....	173-519
1-1/8 UNF .....	174-095
1-1/4 UNF .....	170-130
1-1/4 (Grade 8) .....	175-006
M8 x 1.25MM .....	172-949
M30 x 1.5MM .....	174-902
M50 x 1.5MM .....	175-200

**LOCK NUTS**

#6-32 .....	174-188
#10-32 .....	174-073
1/4 .....	170-069
5/16 .....	170-137
3/8 .....	170-047
7/16 .....	170-239
1/2 .....	170-042
1/2 UNF .....	170-566
1/2 (Grade 8) .....	171-671
9/16 .....	172-220
5/8 .....	170-031
3/4 .....	170-185
3/4 (Grade 8) .....	171-900
3/4 (Grade 8) UNF .....	173-578
7/8 .....	173-069
7/8 UNF .....	171-093
1 .....	174-928
1 UNF .....	170-527
M45 x 1.5MM .....	175-199
M50 x 1.5MM .....	175-197

**JAM NUTS**

1/4UNF .....	171-386
5/16 .....	173-521
3/8 .....	170-022
7/16 .....	170-046
1/2 .....	170-036
5/8 .....	170-037
3/4 .....	170-035
1 .....	174-927

**FLAT WASHERS**

#10 .....	171-525
1/4 .....	170-301
1/4 Heavy .....	171-083
1/4 Fender .....	173-672
5/16 .....	170-127
5/16 Fender .....	173-811
3/8 .....	170-244
3/8 Heavy .....	170-302
3/8 Aluminum .....	173-900
7/16 .....	170-138
1/2 .....	170-040
1/2 (Grade 8) .....	172-984
9/16 .....	173-693
5/8 .....	170-066
5/8 (Grade 8) .....	173-581
3/4 .....	170-015
7/8 .....	173-298
7/8 Heavy .....	170-131
1 .....	170-122
1-1/4 .....	170-928

**LOCK WASHERS**

#6 .....	172-417
#10 .....	171-605
1/4 .....	170-124
5/16 .....	170-118
3/8 .....	170-006
7/16 .....	170-061
1/2 .....	170-003
9/16 .....	173-692
5/8 .....	170-010
3/4 .....	170-016
3/4 External Tooth .....	174-793
7/8 .....	172-003
1 .....	171-021
1-1/4 .....	175-005

**ZERKS**

1/8 NPT .....	170-865
1/8 NPT-45 Deg .....	170-864
1/8 NPT-65 Deg .....	170-215
1/8 NPT-90 Deg .....	170-866
3/16 drive in .....	174-124
1/4-28 .....	170-023
1/4-28 - 45 Deg .....	170-148
1/4-28 - 90 Deg .....	170-049
1/4 NPT .....	170-277
1/4 NPT - 45 Deg .....	174-130

**COTTER PINS**

1/16 x 1/2 .....	170-992
3/32 x 3/4 .....	170-364
1/8 x 1 .....	170-045
1/8 x 1-1/4 .....	170-033
1/8 x 1-1/2 .....	170-382
5/32 x 1 .....	170-421
5/32 x 1-1/2 .....	170-236
5/32 x 3 .....	170-135
3/16 x 1-1/4 .....	170-991
3/16 x 2 .....	170-115
1/4 x 1-1/2 .....	170-521
1/4 x 2 .....	170-056
1/4 x 2-1/2 .....	173-961

**ROLLER CHAIN****CONNECTOR LINKS**

#50 .....	170-088
#50-2R .....	170-094
#60 .....	170-089
#60-2R .....	170-095
#60H .....	171-102
#80 .....	170-090
#80H .....	170-821
#100 .....	170-091
#100H .....	171-969
#120 .....	170-092
#140 .....	170-093
#140H .....	173-552
#160 .....	170-888

**OFFSET LINKS**

#50 .....	170-096
#50-2R .....	170-102
#60 .....	170-097
#60-2R .....	170-103
#60H .....	171-103
#80 .....	170-098
#80H .....	170-820
#100 .....	170-099
#100H .....	172-145
#120 .....	170-100
#140 .....	170-101
#140H .....	173-553
#160 .....	170-887

**ROLLER LINKS**

#50 .....	171-415
#60 .....	171-416
#80 .....	171-417
#80H .....	170-795
#100 .....	171-418
#100H .....	172-146
#120 .....	171-419
#140 .....	171-420
#160 .....	171-421

**PART NUMBER INDEX**

101-761	6	134-831	9	142-025	25	171-428	9
101-911	6,11	134-842	5	142-026	25	171-442	25
101-986	9	134-846	9	142-027	13	171-550	15
101-988	9	134-874	9	142-028	13	171-586	9
102-070	16	134-875	9	142-031	13	171-607	5
102-073	25	134-889	6	142-032	13	171-696	9
102-205	11	134-892	11	142-035	13	171-712	26
102-207	11	134-893	11	142-082	9	171-759	17
102-208	9	134-899	9	170-002	9	171-769	5
102-212	5	134-902	9	170-008	5,9	171-774	9
102-213	11	134-906	5	170-031	9	171-782	9,25
102-214	11	134-907	5	170-037	9	171-799	15,26
102-215	5	134-908	5	170-042	9	171-820	26
102-216	13	134-918	5	170-052	16	171-821	26
102-224	11	134-969	16	170-053	5	171-877	22
102-225	11	134-970	16	170-066	9	171-900	22
102-226	11	135-540	5	170-073	9	171-913	26
102-235	13	135-541	5	170-074	9	171-915	26
102-236	16	135-550	11	170-122	9,25	171-919	6
102-238	13	135-551	5	170-151	16	171-934	11
102-240	13	135-555	13	170-152	11	171-935	5,11
102-241	13	135-596	11	170-161	25	171-968	11
102-519	13	135-597	11	170-168	11	171-974	15
102-520	13	135-598	5	170-168	11	171-975	15
102-521	13	135-598	5	170-233	25	171-976	15
102-905	23	135-607	6	170-236	9	171-977	15
103-517	13	135-608	9	170-244	5,11	171-978	15
103-622	9	135-611	11	170-290	16	171-978	15
103-762	25	135-612	11	170-316	17	171-979	15
103-768	25	135-613	5	170-364	11	171-980	15
103-920	23	135-614	5	170-366	26	171-981	15
104-034	25	136-119	17	170-466	25	171-982	15
104-038	5	136-174	17	170-490	26	171-983	15
104-041	9	136-284	11	170-518	6	171-989	11
104-044	25	136-285	11	170-545	20,21	171-998	25
130-175	5	136-286	5	170-546	20,21	172-005	6
131-845	16	136-296	22	170-627	16,17	172-024	11
133-027	16	136-297	22	170-638	20	172-024	5
133-028	16	136-298	22	170-639	20	172-029	15
133-029	16	136-299	22	170-679	20,21	172-030	15
133-277	9	136-495	9	170-800	6	172-031	15
133-288	9	136-716	13	170-812	26	172-032	15
133-476	5	136-717	13	170-813	26	172-033	15
133-530	5	136-979	13	170-835	5,9	172-036	15
133-637	9	140-495	25	170-845	6	172-037	15
134-155	11	140-496	25	170-849	26	172-038	15
134-155	6	140-497	25	170-865	5,11	172-039	15
134-460	9	140-863	25	170-950	11	172-040	15
134-481	11	140-871	25	170-952	11	172-042	9
134-602	5	140-878	25	171-030	9,25	172-046	11
134-649	9	140-879	25	171-045	6	172-171	26
134-786	5	141-275	13	171-137	11	172-207	15
134-792	5	141-276	13	171-251	25	172-209	15
		142-003	9	171-252	6	172-210	15
		142-023	25	171-384	16		

**PART NUMBER INDEX**

172-287 ..... 5	173-135 ..... 20	171-384 ..... 19
172-288 ..... 5	173-136 ..... 20	171-387 ..... 19
172-355 ..... 5	173-137 ..... 21	171-567 ..... 19
172-421 ..... 9	173-138 ..... 21	171-568 ..... 19
172-422 ..... 9	173-141 ..... 20,21	171-633 ..... 19
172-599 ..... 25,26	173-142 ..... 20	171-634 ..... 19
172-751 ..... 6,11	173-144 ..... 20,21	171-635 ..... 19
172-759 ..... 26	173-145 ..... 20	171-636 ..... 19
172-772 ..... 9	173-147 ..... 20,21	171-637 ..... 19
172-774 ..... 15,16	173-149 ..... 20,21	171-638 ..... 19
172-775 ..... 15	173-150 ..... 20	171-639 ..... 19
172-780 ..... 16	173-151 ..... 21	171-640 ..... 19
172-786 ..... 16,26	173-152 ..... 20,21	171-641 ..... 19
172-787 ..... 25,26	173-153 ..... 20,21	171-642 ..... 19
172-793 ..... 25	173-154 ..... 21	171-643 ..... 19
172-794 ..... 25	173-231 ..... 22	171-644 ..... 19
172-806 ..... 25	173-232 ..... 22	171-645 ..... 19
172-807 ..... 25	173-271 ..... 9	171-646 ..... 19
172-808 ..... 25	173-273 ..... 9	171-647 ..... 19
172-809 ..... 25	173-274 ..... 9	171-648 ..... 19
172-820 ..... 26	173-275 ..... 9	171-649 ..... 19
172-821 ..... 25,26	173-646 ..... 25	171-650 ..... 19
172-822 ..... 5,11	173-760 ..... 23	171-651 ..... 19
172-823 ..... 5,11	174-514 ..... 26	171-652 ..... 19
172-831 ..... 6	174-686 ..... 26	171-848 ..... 19
172-866 ..... 9	174-687 ..... 26	171-849 ..... 19
172-872 ..... 11	174-720 ..... 26	172-743 ..... 7
172-873 ..... 11	174-848 ..... 25	172-776 ..... 19
172-874 ..... 5	174-849 ..... 25	173-646 ..... 7
172-875 ..... 9	175-035 ..... 9	174-529 ..... 7
172-876 ..... 6	175-116 ..... 23	174-531 ..... 7
172-883 ..... 26	175-133 ..... 17	174-532 ..... 7
172-894 ..... 5	175-134 ..... 17	174-533 ..... 7
172-896 ..... 16	175-135 ..... 17	174-534 ..... 7
172-899 ..... 16	175-204 ..... 23	174-535 ..... 7
172-900 ..... 16	175-281 ..... 26	174-536 ..... 7
172-901 ..... 16	175-282 ..... 26	174-537 ..... 7
172-902 ..... 16	175-299 ..... 9	174-541 ..... 7
172-904 ..... 16	175-327 ..... 26	174-542 ..... 7
172-905 ..... 16	175-328 ..... 26	174-715 ..... 7
172-910 ..... 6	180-630 ..... 5,11	174-734 ..... 7
172-911 ..... 6	103-921 ..... 23	174-735 ..... 7
172-912 ..... 6	103-510 ..... 7	175-206 ..... 23
173-027 ..... 5	103-511 ..... 7	
173-040 ..... 26	103-513 ..... 7	
173-045 ..... 17,20	134-922 ..... 19	
173-046 ..... 17,21	140-170 ..... 7	
173-047 ..... 17	170-027 ..... 19	
173-121 ..... 20	170-118 ..... 19	
173-122 ..... 20	170-119 ..... 19	
173-123 ..... 21	170-579 ..... 19	
173-124 ..... 21	170-627 ..... 19	
173-127 ..... 20,21	171-062 ..... 7	
173-128 ..... 20,21	171-199 ..... 7	