

Model
VCS5007
Shown

USER'S MANUAL for Models VCS5037

Gas Barbecue Grill (Propane & Natural Gas)



Warnings

DANGER

If you smell gas:

1. Shut off gas to the appliance;
2. Extinguish any open flame;
3. Open lid;
4. If odor continues, keep away from the appliance and immediately call your gas supplier or your fire department.

WARNING

Do not store or use gasoline or other flammable liquids or vapors in the vicinity of this or any other appliance.

An LP cylinder not connected for use shall not be stored in the vicinity of this or any other appliance.

- Always read and understand the **WARNINGS** and **SAFETY INSTRUCTIONS** that are contained in this Manual before attempting to use this Gas Barbecue Grill, to prevent possible bodily injury or property damage.
- Always keep this Manual in a safe place, for convenient future reference.
- Never store flammable or easily combustible objects (matches, butane lighters, cloths, etc.) in the pull out warming drawer (if equipped).

SIGNAL WORDS:

The Signal Words used in this Manual, and their intended meanings, are as follows :

DANGER: Indicates that a failure to observe the safety instructions could result in death or catastrophic bodily injury.

WARNING: Indicates that a failure to observe the safety instructions could result in serious bodily injury.

CAUTION: Indicates that a failure to observe the safety instructions could result in property damage or minor bodily injury.

NOTE: Designates important information relating to the safe use of the Grill.

IMPORTANT WARNINGS:

Since this outdoor cooking appliance is movable, is fueled by natural or propane gas, generates very high temperatures for cooking and emits carbon monoxide as a by-product of combustion, prudent precautions must be taken to assure its safe use.

- **DANGER:** This Grill has been designed for OUTDOOR use only.

Never use this outdoor Grill inside any building, garage, shed or breezeway, or inside any boat, trailer or recreational vehicle, to prevent a possible fire and to prevent the possibility of carbon monoxide poisoning or asphyxiation

- **DANGER:** Exposing an overfilled or a disconnected propane cylinder to heat could cause venting of fuel through the pressure release valve. Since propane vapor is heavier than air it tends to pool and, if ignited, could produce a violent fire or explosion.

Never install a propane cylinder if it is more than 80% full, as the contents may lack adequate room for expansion when exposed to heat.

Never store a spare Propane Gas Cylinder in the cylinder compartment of this Grill, because it will be exposed to high temperatures when the Grill is in use.

This Gas Barbecue Grill will provide you with many years of pleasure and enjoyment, if it is used in accordance with the Warnings and Safety Instructions contained in this Manual.

The essential Warnings and Safety Instructions are located throughout the pages of this Manual, but some of the principal ones have been summarized as follows for your convenience:

Warnings

A. SAFE LOCATIONS FOR USE OF THIS OUTDOOR GRILL

DANGER:

- Never use this outdoor Grill inside any building, garage, shed or breezeway, or inside any boat, trailer or recreational vehicle, to prevent a possible fire and to prevent the possibility of carbon monoxide poisoning or asphyxiation.

WARNINGS:

- Always confirm that this Grill is not positioned under a combustible object (e.g., an awning or umbrella) or in a covered area (e.g., a porch or gazebo) before lighting it, to prevent a possible fire.
- Always confirm that this Grill is not positioned under the overhang of a house, a garage or other structure before lighting it. An overhang will serve to deflect flare-ups and radiated heat into the structure itself, which could result in a fire.

- Always confirm that this Grill is positioned more than 36" (1 m) away from any combustible materials or surfaces before lighting it, and that no gasoline or other volatile substances are stored in the vicinity of this Grill. The temperature of a grease fire or of the radiated heat might otherwise be sufficient to ignite nearby combustibles or volatile substances.

- Always locate this Grill where there will be ample combustion and ventilation air, but never position it in the direct path of a strong wind.

- Never allow the Grill to operate while unattended, to prevent uncontrolled grease fires from erupting.

Never attempt to move this Grill while it is in operation or while it is still hot, to prevent possible personal injury.

- Never store or use gasoline or other flammable or volatile substances inside or in the vicinity of this Grill or in the vicinity of any other heat-generating appliance, because of the danger of starting a fire.

- Always confirm that the installation of this Grill conforms with the requirements of all local Codes or, in the absence of any applicable local Codes, with either the National Fuel Gas Code, ANSI Z223.1/NFPA54, or CAN/CGA-B149.1-05, Natural Gas and Propane Installation Code.

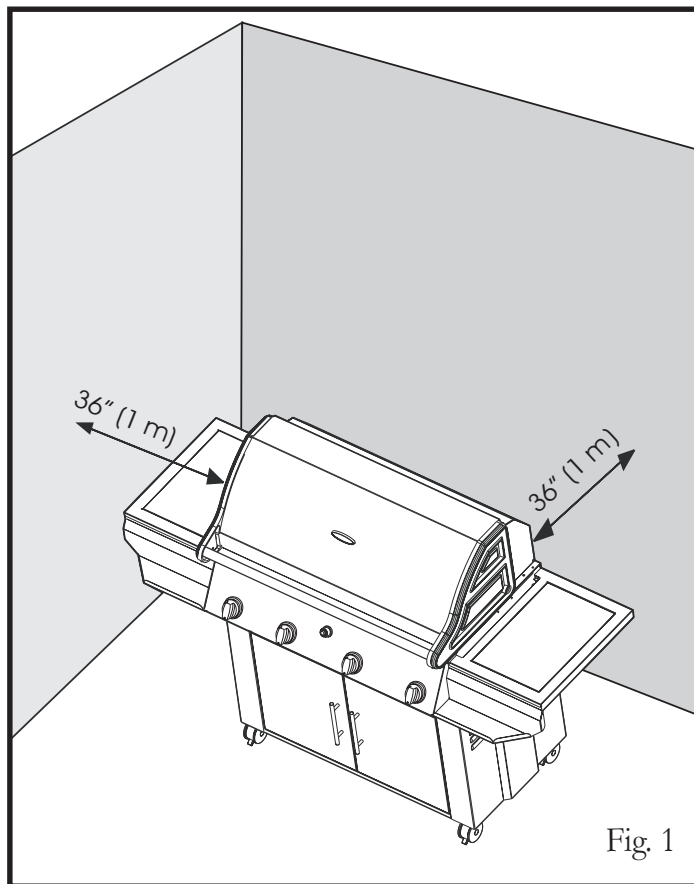

B. SAFE USE OF LP (PROPANE) GAS

DANGER:

- Never install a propane cylinder that is more than 80 % full, as the contents may lack adequate room for expansion when exposed to heat. Propane vapor may then be vented through the pressure release valve, which could accumulate in a pool and later result in a fire or explosion.

Always instruct your certified propane fuel supplier to confirm by weight that your cylinder is not more than 80 % full. An empty cylinder will weigh about 19 lb., while a properly filled cylinder should weigh no more than 39 lb.

- Never store a spare Propane Cylinder in the cylinder compartment of this Grill. Exposing a disconnected cylinder to heat could result in the venting of propane vapor through the pressure release valve, and the pooled vapor could result in a violent fire. (No hazard is posed by the connected cylinder if it is not overfilled, however, as it tends to refrigerate itself while it is being used.)
- Always confirm that all openings in the cylinder compartment of this Grill are free of any obstructions that would restrict the circulation of ventilation air. Good ventilation will prevent the pooling of leaked propane vapor, which is heavier than air, and which could explode if ignited.

WARNINGS:

- Always consult the Rating Label on the back of the Grill to confirm which fuel must be used with the Grill. Never operate the Grill with propane gas if it has been configured to use natural gas, to prevent hazardous overheating.
- Always confirm that there are no gas leaks before lighting this Grill. Apply a 50/50 solution of liquid soap and water to the gas supply line connectors with a brush or spray bottle, and watch for bubbles. Never use a match or open flame to test for gas leaks.
- Always visually inspect the gas supply line for fraying, cracking or rodent damage before each use of this Grill and, if necessary, install a replacement obtained from your dealer before lighting this Grill.

Always store your spare Propane Gas Cylinders in an outdoor area that is well-ventilated, shady, cool and removed from any heat source. Always store those cylinders in an upright position. Never store a spare cylinder in the vicinity of this Grill, or in the vicinity of any other heat-generating appliance.

C. SAFE USE OF NATURAL GAS

- Always consult the Rating Label on the back of the Grill to confirm which fuel must be used with the Grill. Never attempt to operate the Grill with natural gas if it has been configured to use propane gas, to prevent possible bodily injury.
- Always employ a qualified service agency to install all necessary gas supply plumbing, for safety reasons and to assure compliance with all applicable Codes.

Safety

- Always promptly shut off the gas supply and immediately extinguish all flames if you smell gas. Always seek assistance from your gas supplier or local Fire Department if the gas smell persists, because of the danger of fire or explosion.
- Always confirm that there are no gas leaks before lighting this Grill. Apply a 50/50 solution of liquid soap and water to the gas supply line connectors with a brush or spray bottle, and watch for bubbles. Never use a match or open flame to test for gas leaks.
- Always visually inspect the gas supply line for fraying, cracking or rodent damage before each use of this Grill and, if necessary, install a replacement before lighting this Grill.
- Never permit a gas supply line to contact any heated surface of this Grill.
- Ensure the Grill is properly cooled before placing the cover back on the Grill.

D. PREVENTION OF BURNS

- Always keep children and pets under close supervision when using this Grill, and never permit them to come near the Grill while it is in use, as the exterior surfaces will be very hot.
- Always wear insulated protective mitts when working at the Grill, or when attempting to close a gas supply valve after cooking has been completed, to prevent possible burns. Always use insulated pot holders when handling containers of hot food.
- Always wear an insulated protective mitt when adding a smoking agent to a Smoker Box.
- Never store or use gasoline or other flammable or volatile substances in the vicinity of this Grill, or in the vicinity of any other heat-generating appliance.

E. ELECTRICAL SAFETY

- Always confirm that this Grill has been grounded in accordance with local Codes or, in the absence of local Codes, with the National Electrical Code, ANSI/NFPA No. 70 or the Canadian Electrical Code, CSA C22.1, when an external electrical source is being utilized for the Rotisserie Motor.
- Always use a grounded three-prong outlet and a three-prong extension cord to energize the Rotisserie Motor. Never alter or remove the grounding prong on the Rotisserie Power Cord, as an electric shock hazard would then result.
- Never permit an electrical supply cord to contact any heated surface of this Grill.

Safety

FUELS

WARNING: Never use Natural Gas in a Grill that has been configured to burn Propane Gas, and never use Propane Gas in a Grill that has been configured to use Natural Gas, to avoid possible bodily injury. Always consult the Rating Label on the back of your Grill to confirm which fuel must be used with the Grill.

WARNING: Use only the pressure regulator and type I propane gas supply coupling and hose that is originally provided with this appliance or as specified, (see Fig. 2).

ADDITIONAL WARNINGS:

- Always install a 20 lb. propane cylinder that is equipped with a type I valve outlet (see Fig. 3), and that has a 12” diameter and an 18” height. Always use a propane cylinder that has been constructed and marked in conformance with either the specifications for LP Gas Cylinders of the U.S. Department of Transportation or the specifications in the National Standard of Canada, CAN/CSA-B339, Cylinder, Spheres and Tube for Transportation of Dangerous Goods, as applicable.
- Always confirm that your propane cylinder is equipped with a shutoff valve terminating in a Type I propane cylinder valve outlet connection, and that it has been provided with a collar to protect the cylinder valve.
- Never install a propane cylinder in this Grill unless it is equipped with a listed Overfill Protection Device (OPD).
- Always have a new propane cylinder properly purged of air by your certified propane gas dealer. Since a new cylinder is initially filled with air, the air must first be purged before it is filled with propane.
- Always visually inspect the gas supply line for fraying, cracking or rodent damage before each use of this Grill and, if necessary, install a replacement obtained from your dealer prior to lighting this Grill.
- Place dust cap on cylinder valve outlet whenever the cylinder is not in use. Only install the type of dust cap on the cylinder valve that is provided with the cylinder valve. Other types of caps or plugs may result in leakage of propane.

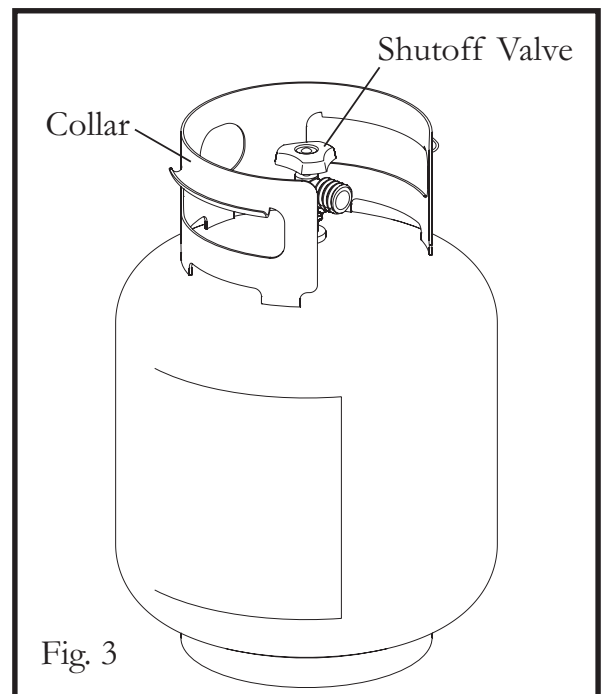
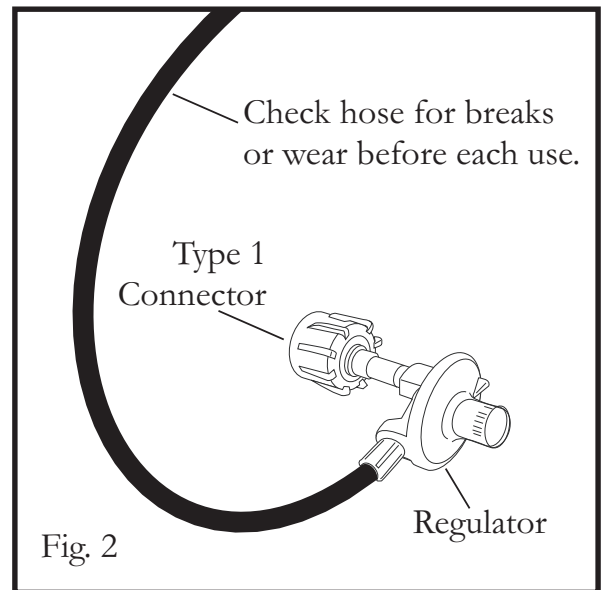

DANGER:

- a) Do not store a spare LP - Gas Cylinder under or near this appliance
- b) Never fill the cylinder beyond 80% full; and
- c) If the information in a) and b) is not followed exactly, a fire causing death or serious injury may occur.

WARNING: Always confirm that the openings in the cylinder compartment of the Grill are free of any obstructions that would restrict the circulation of ventilation air. Good ventilation will prevent any possible accumulation of leaked propane vapor, which is heavier than air and which could explode if ignited.

NOTE: Always have a certified propane gas supplier inspect and re-qualify your refillable propane gas cylinder prior to each refilling, in accordance with DOT or TC requirements for propane cylinders.

ADDITIONAL WARNINGS:

- Always handle propane cylinders with great care, as the contents are under high pressure.
- Always close the propane cylinder valve promptly after each use of the Grill.
- Always store propane cylinders outdoors, in an upright, secure position, out of direct sunlight, away from living quarters and in a well-ventilated, cool, dry area. **NEVER STORE A CYLINDER IN A BUILDING, GARAGE OR OTHER STRUCTURE OR ENCLOSED AREA.**
- Always keep cylinders out of reach of children.
- Always confirm that a valve dust cap has been tightly installed and that the valve itself is fully closed, whenever a propane cylinder has been disconnected.
- Always transport a propane cylinder in an upright, secure position, after confirming that its valve is closed.
- Always stabilize a cylinder so that it cannot move, when it is being transported in a car trunk.
- Never transport a propane cylinder in the passenger compartment of a car or truck.
- Never store a Gas Grill indoors, unless the propane cylinder has first been disconnected and removed from the Grill.
- Never expose a propane cylinder to any heat source, never apply heat directly to a cylinder and never store a spare cylinder in the vicinity of this Grill.
- Never paint a propane cylinder a dark color, as this can cause the cylinder and its contents to overheat.
- The LP cylinder must be arranged for vapor withdrawal. The cylinder must be upright with the valve at the top. (Fig. 3)

Gas Hookup

Hooking Up to the LP (Propane) Gas Supply

FOR YOUR SAFETY

1. **WARNING:** Never store or use gasoline or any other volatile substance in the vicinity of this Grill.
2. **WARNING:** Never store a spare propane cylinder in the vicinity of this Grill, or in the vicinity of any other potential heat source.

LP (PROPANE) GAS SUPPLY CONNECTION

1. Always place the propane tank in the tank locator hole in the bottom pan of the cylinder compartment and insure it is secured into place.
2. Always confirm that all burner control knobs are in the OFF position before activating the gas supply.
3. Always connect the gas supply regulator as follows:

Insert the nipple of the valve coupling into the tank valve and tighten the connection collar by turning it clockwise with one hand while holding the regulator with the other (see Fig. 4).

WARNING: Always conduct a leak test before lighting the Grill, to prevent a possible fire or explosion (see page 5).

CAUTION: For connection of an LP gas grill to a fixed pipe LP bulk system, consult your local gas supplier.

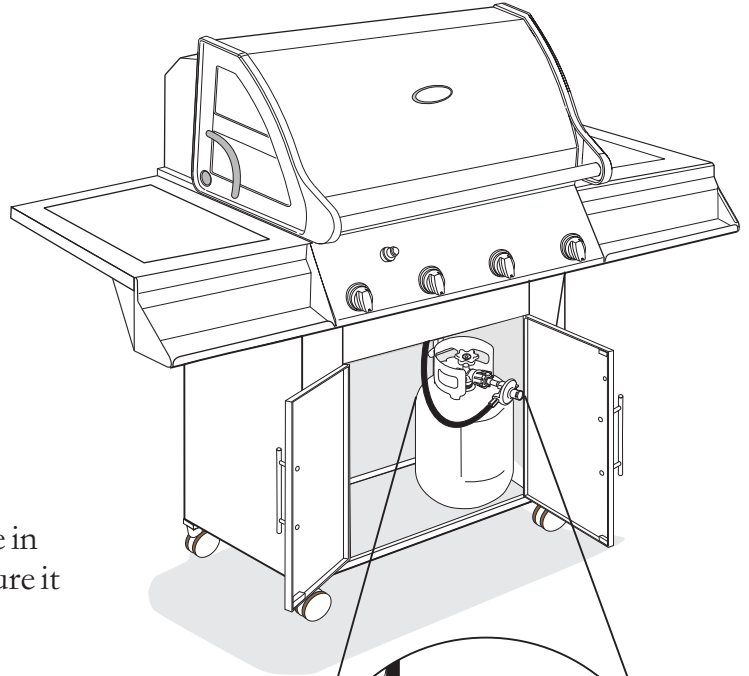

Fig. 4

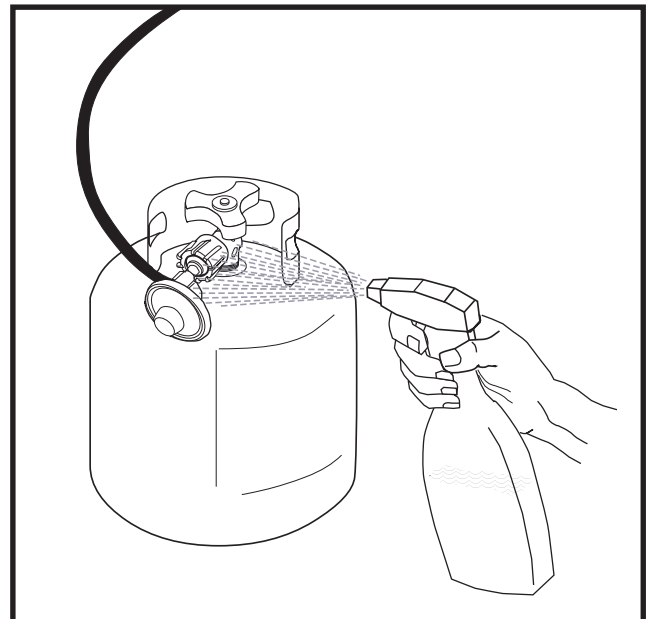

Fig. 5

Gas Hookup

NATURAL GAS SUPPLY CONNECTION

TO CONNECT:

1. Push back the Sleeve on the Socket as shown below (see Fig. 6a).
2. Insert Plug and release the Sleeve (see Fig. 6b).
3. Push the Plug until Sleeve snaps forward to lock the Plug in the Socket.

- **WARNING:** Always conduct the following safety tests before lighting the Grill, to prevent a possible fire or explosion (see leak test below).

TO DISCONNECT:

1. Push Sleeve back and pull the Plug out.

TESTING FOR GAS LEAKS (for LP and Natural Gas)

Before attempting to operate this Grill:

1. Always confirm that all burner control knobs are in the OFF position.
2. Always connect the gas supply hose first and then open the gas shutoff valve.
3. Always use a brush or spray bottle to apply a 50/50 solution of liquid soap and water to all connection points (see Fig. 5) to test for gas leaks. Never use a match or open flame for that purpose.
4. Always look for bubbles to appear, as the appearance of bubbles will indicate a gas leak. Always turn off the gas immediately and tighten the connection, if you find that a leak exists.
5. Always repeat this procedure until no further gas leaks are found to exist, before lighting the Grill.
6. Never attempt to light this Grill, however, if a leak cannot be stopped. Always call your gas supplier promptly to obtain assistance.

WARNINGS:

- Always consult the Rating Label on the back of the Grill to confirm that it has already been configured to burn Natural Gas.
- All gas supply plumbing should be performed only by a qualified service agency. In the U.S., the supply connection must be made in accordance with local code or, in the absence of local codes, with the national fuel gas codes, ANSI Z223.1/NFPA54. In Canada, the supply connection shall be carried out in accordance with the provincial authorities having jurisdiction and in accordance with the requirements of the CAN/CGA 1-B149.1 installation code. A shutoff valve must be installed between the gas grill and the main supply. For natural gas, use a 3/8" or 1/2" natural gas supply line capable of an a input of up to 100,000 BTUs (depending on the model).
- Always disconnect the Grill and close its individual manual shutoff valve, when conducting pressure tests of the gas supply piping system at pressures which exceed 1/2 psi (3.5 kPa).
- Always isolate the Grill from the gas supply piping system by closing its individual manual shutoff valve.

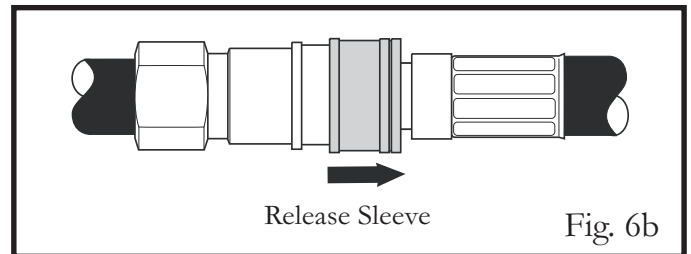
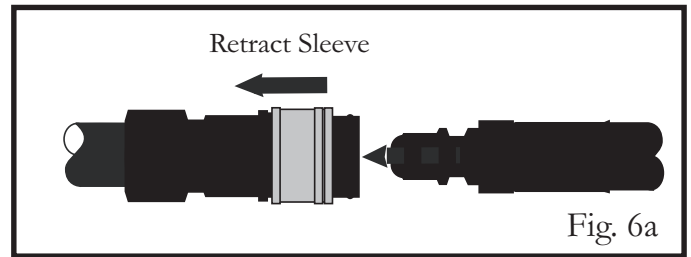

Operation

CONTROL FUNCTIONS

PROPANE TANK VALVE

WARNING: Never open the Tank Valve unless the Grill is being prepared for use, to prevent the pooling of propane vapor.

Always open the Valve immediately before lighting the Grill, and always close it immediately after cooking has been completed.

BURNER CONTROL VALVES (see Fig. 7)

On Models VCS3507, VCS3517 & VCS3507BI, there are three independent control valves for the main burners, and a separate control valve for the rotisserie burner (if equipped).

On Models VCS4007, VCS4017, VCS4027, & VCS4037, there are four independent control valves for the main burners, and a separate control valve for the rotisserie burner.

On Models VCS5007, VCS5017, VCS5027, VCS5037, & VCS5007BI, there are five independent control valves for the main burners, and a separate control valve for the rotisserie burner.

The OFF position is indicated above each knob. A full range of flame adjustment is available from High to Low, (by turning a knob counterclockwise).

ACTIVATING THE IGNITER

ELECTRONIC IGNITION SYSTEM

As you push and hold the Igniter Button, you will hear a series of clicks as the igniter module generates an ignition spark to the burners. The burner should light within five seconds. Depending on which model you have, the system is powered by either a single “AA” or a single “AAA” battery. Ensure the battery has been installed before using the igniter. To remove or replace the battery, turn the push button knob counterclockwise, and carefully pull out the spring and battery. Ensure that the positive end of the battery is in the down (bottom) position before replacing the knob.

PIEZO IGNITION SYSTEM (if equipped)

As you turn the Igniter Knob clockwise, you will hear a click as the Piezo module generates an ignition spark to the burner. Rotate the Igniter Knob until the burner lights. The burner should light within five seconds.

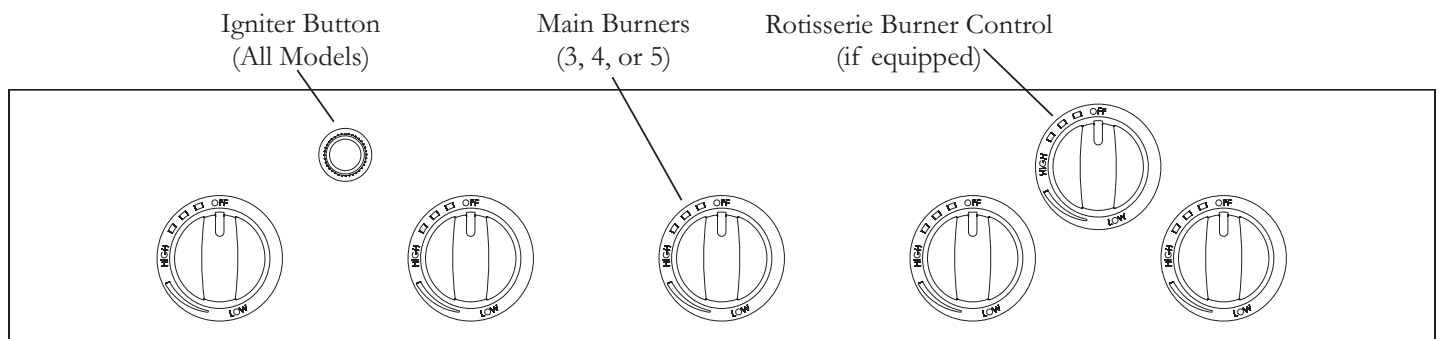

(VCS5007 Model Shown)

Operation

LIGHTING THE MAIN BURNERS

1. a. Always open the Hood completely and always inspect the Grill and burners to confirm that all components are properly positioned before lighting the main burners.
- b. Make sure the grease cup is empty and grease tray is clean.
- c. Always visually inspect the gas supply line for fraying, cracking, or rodent damage before lighting the grill and, if necessary, install a replacement obtained from your dealer prior to lighting the grill.

WARNING: Never stand with your head directly over the Grill when preparing to light the main burners, to prevent possible bodily injury.

2. Always confirm that all of the burner control knobs are in the OFF position before opening the gas supply.
3. Turn on the propane gas supply valve at the tank (1 to 2 turns) or turn on the main natural gas supply valve (see Fig. 8).
4. Turn the selected Burner Control Knob to the HIGH position by pushing down on the knob and turning it counter-clockwise.
5. Immediately activate the Igniter (see Page 6). The selected burner should light within five seconds. Light the burners sequentially from either left to right or right to left.

WARNING: IF THE SELECTED BURNER DOES NOT LIGHT, immediately turn the burner control knob to the OFF position, to prevent gas buildup. Wait five (5) minutes for the gas to clear and then repeat the preceding starting procedure. If the burner will not light when using the Igniter, follow the match lighting instructions (see Page 8).

6. Confirm that the burner is properly lit and that the flame pattern is as desired, (see Figs. 9a, 9b & 9c, for the proper flame patterns). If the flame pattern is other than normal, consult the Troubleshooting Guide on Page 23 for corrective action.
7. Always preheat the grill before starting cooking. Light all burners and adjust them to the HIGH position for 5 to 10 minutes or until the Grill reaches the desired cooking temperature. Before placing any food on the Grill, make sure that the cooking surface is free from food and debris.
8. Adjust the Controls to a medium setting for most cooking requirements. A light coating of cooking oil on the cooking grids, before heating the Grill, will help prevent foods from sticking to the Grill.

NOTE: When lighting the grill for the first time, burn with the main burners on HIGH for at least 30 minutes, to burn off any manufacturing residues.

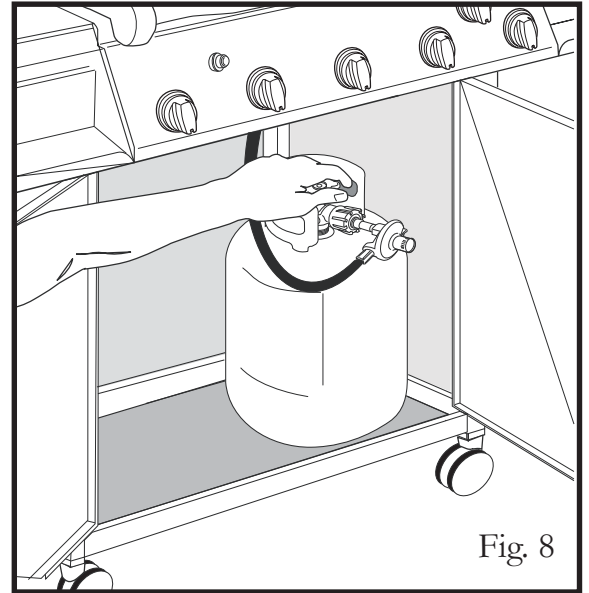

Fig. 8

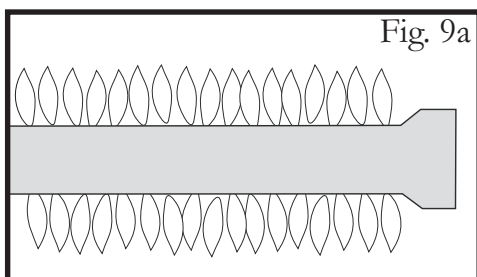

Fig. 9a

Normal: Soft blue flames

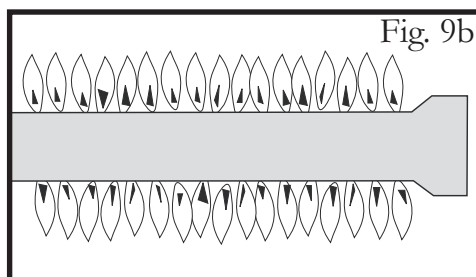

Fig. 9b

Out of Adjustment: Noisy, hard blue flames indicate too much air

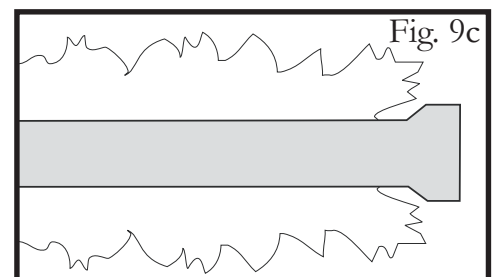

Fig. 9c

Poor Combustion: Wavy yellow flames indicate too little air

Operation

TURNING THE BURNERS OFF

1. Always turn the burner control knob(s) to the OFF position when cooking has been completed.
2. Promptly turn OFF the gas supply valve at the propane cylinder or at the main natural gas supply line.
3. Close the Hood of the Grill.

FLARE-UPS

“Flare-ups” sometimes occur when food drippings fall onto the hot sear plates or burners and ignite. Some flaring is normal and desirable, as it helps impart the unique flavors associated with grilled foods. Controlling the intensity of the flare-ups is also desirable, however, in order to avoid burned or unevenly cooked foods and to prevent the possibility of an accidental fire.

WARNING: Always monitor the Grill carefully while cooking and turn the flame level down (LOW), or OFF, if flare-ups intensify. To prevent uncontrolled grease fires from erupting, never allow the grill to operate while unattended.

MATCH LIGHTING THE MAIN BURNERS:

1. a. Always open the Hood completely and always inspect the Grill and burners to confirm that all components are properly positioned before lighting the main burners.
- b. Make sure the grease cup is empty and grease tray is clean.
- c. Always visually inspect the gas supply line for fraying, cracking, or rodent damage before lighting the grill and, if necessary, install a replacement obtained from your dealer prior to lighting the grill.

WARNING: Never stand with your head directly over the Grill when preparing to light the main burners, to prevent possible bodily injury.

2. Always confirm that all of the burner control knobs are in the OFF position before opening the gas supply.
3. Always turn on the propane gas supply valve at the tank (1 to 2 turns) or turn on the main natural gas supply valve.
4. Insert a lit match or a butane lighter into the match lighting hole located on the left hand side of the base, (see Fig. 10).
5. Turn the left Burner Control Knob to the HIGH position by pushing down on the knob and turning it counterclockwise.
6. Never store flammable or easily combustible objects (matches, butane lighters, cloths, etc.) in the pull out warming drawer (if equipped).

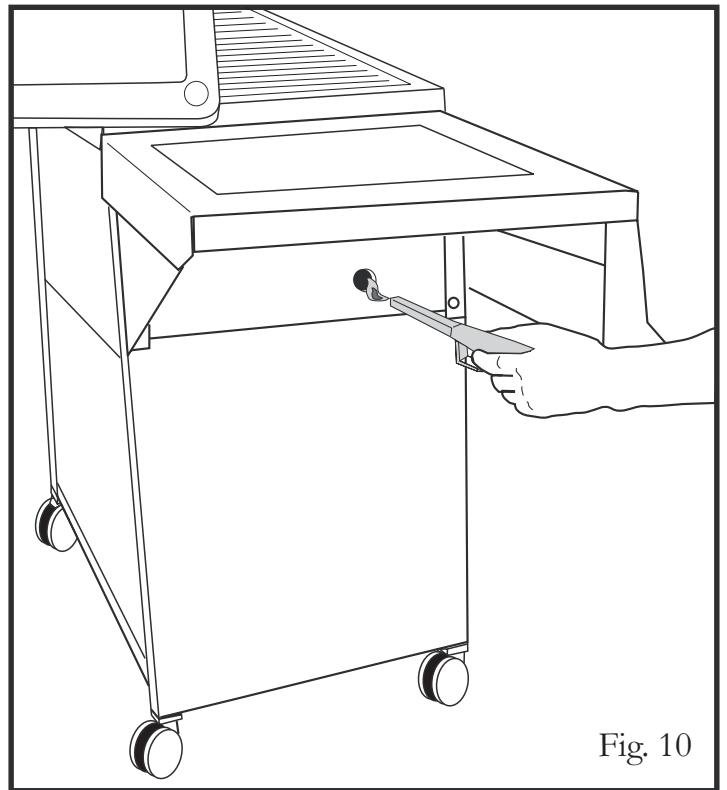

Fig. 10

LIGHTING THE ROTISSERIE BURNER (if equipped)

The Rotisserie burner provides the steady, even heat required to cook poultry and roasts to self-basted perfection.

TO START THE ROTISSERIE BURNER:

1. Always open the Hood completely before attempting to light the Grill.
- **WARNING:** Never stand with your head directly over the Grill when preparing to light the Rotisserie burner, to prevent possible bodily injury.
2. Always confirm that all of the burner control knobs are in the OFF position before opening the gas supply.
3. Turn on the propane gas supply valve at the tank (1 to 2 turns) or turn on the main natural gas supply valve.
4. Turn the Rotisserie Burner Control Knob to the HIGH position, by pushing down on the knob and turning it counterclockwise.
5. Immediately push the Igniter Button. The Rotisserie burner should light within five seconds.
- **WARNING:** IF THE ROTISSERIE BURNER DOES NOT LIGHT, immediately turn the burner control knob to the OFF position, to prevent gas buildup. Wait five (5) minutes for the gas to clear and then repeat the preceding starting procedure. If the burner will not light when using the Igniter, follow the match lighting instructions below.
6. Confirm that the burner is properly lit and that the flame pattern is as desired, (see Figs. 9a, 9b & 9c, for the proper flame patterns). If the flame pattern is other than normal, consult the Troubleshooting Guide on Page 22 for corrective action.
7. Always preheat the Grill before starting to cook on the rotisserie.
8. Never operate the main burner when the rotisserie burner is on.

MATCH LIGHTING THE ROTISSERIE BURNER:

1. Always open the Hood completely, before attempting to light the Grill.

WARNING: Never stand with your head directly over the Grill when preparing to light the Rotisserie Burner, to prevent possible bodily injury.

2. Always confirm that all of the burner control knobs are in the OFF position before opening the gas supply.
3. Turn on the propane gas supply valve at the tank (1 to 2 turns) or turn on the main natural gas supply valve.
4. Insert a lit match or a butane lighter into the match lighting hole located below the rotisserie screen (see Fig. 11).
5. Turn the Rotisserie Control Knob to the HIGH position by pushing down on the knob and turning it counterclockwise.

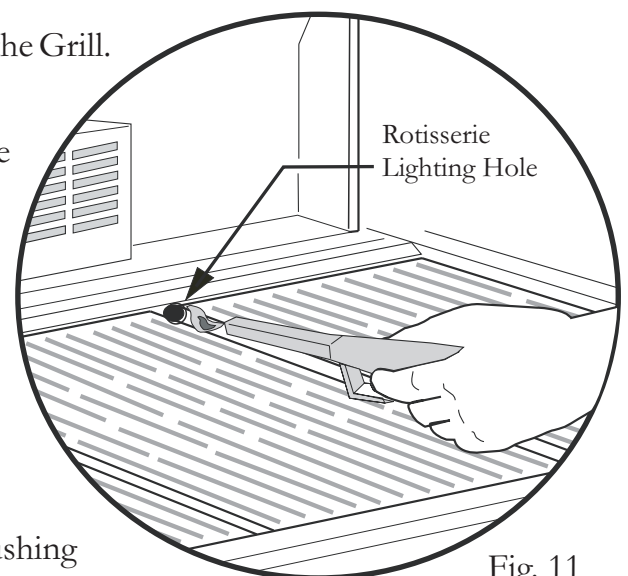

Fig. 11

Operation

ROTISSERIE SETUP (if equipped)

The Rotisserie burner is intended to be used for rotisserie cooking only.

WARNING: Never use the main burners while using the Rotisserie burner, as that could result in igniting the drippings, or overheating your Grill, which could result in damage of the Grill.

The Rotisserie assembly includes a counter-weight for large or irregular food items ; using the counterweight will reduce the strain on the motor.

1. Remove the warming rack. Lay a flat pan directly on the cooking grates to catch drippings. Large food items may require that you remove the middle cooking grate(s), and place the pan on the sear plates.

2. Insert the ends of the Rotisserie Support into the slots of the right cooking grate, so that the edge of the support is approximately 1” from the right casting, and the top groove is in line with the rotisserie spit hole in the left casting (see Fig. 12a).

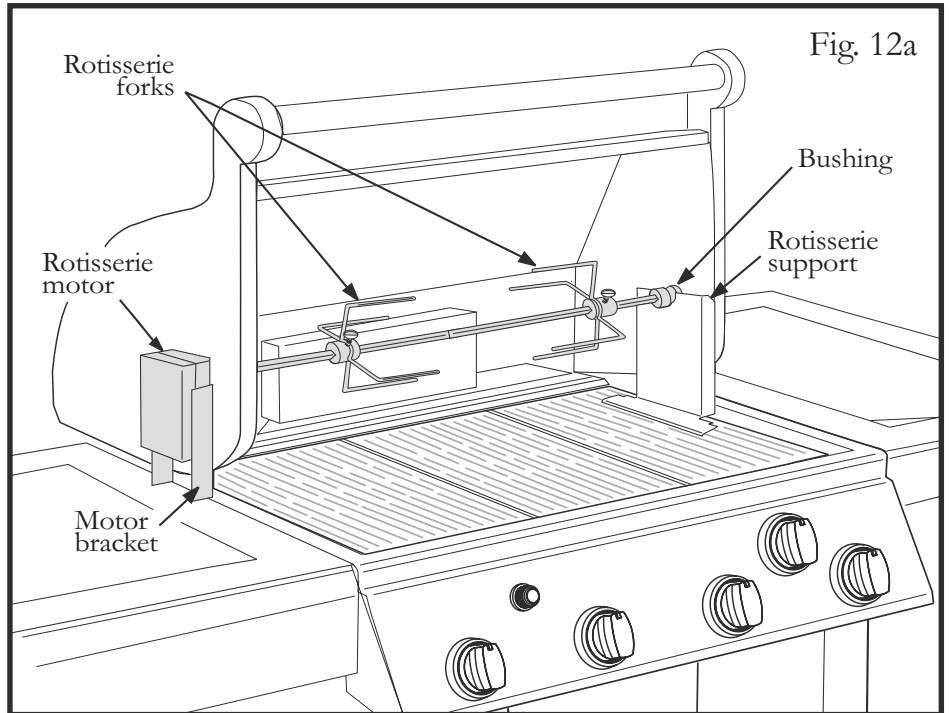

3. Engage the Motor Bracket to the left side of the base as per Rotisserie instructions.

4. Engage the Rotisserie Motor in the Motor Bracket (see Fig. 12a).

5. Assemble the spit and meat forks. Adjust the retainer bushing to keep the spit in place (see Fig. 12a).

6. Tighten the thumbscrews with small pliers.

7. Insert the Spit Rod into the Rotisserie Motor (see Fig. 12b).

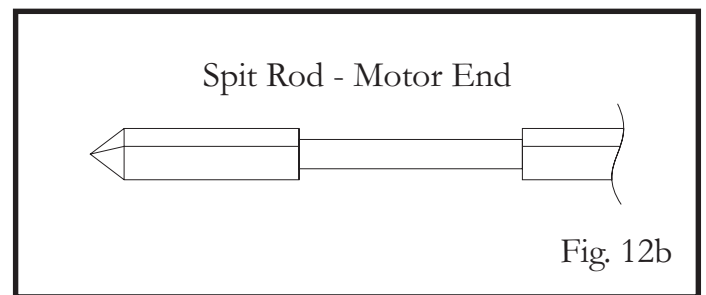

NOTES: Always use the counterweight to balance the spit when cooking large or irregular food items. The Rotisserie Motor is rated to turn a maximum load of 12 lb.

WARNINGS:

- Never use the Rotisserie Motor in the rain, and never use it if it has become wet.
- Always use a grounded three-prong outlet and a three-prong extension cord to energize the Rotisserie Motor. Never alter or remove the grounding prong on the Rotisserie Power Cord, as an electric shock hazard would then result.
- Never permit an electrical supply cord or a gas supply line to contact any heated surface of this Grill.

LIGHTING THE SIDE BURNER (if equipped)

WARNING: Never stand with your head directly over the Grill when preparing to light the side burner, to prevent possible bodily injury.

1. Turn the side burner control knob to HIGH (see Fig. 13).
2. Turn the Igniter Knob clockwise until the burner ignites. The burner should light within four clicks of the igniter. **NOTE:** Some models are equipped with an electronic igniter. Refer to page 6 for respective piezo and electronic igniter systems.

NOTE: Observe the flame pattern. Soft blue flames are normal ; hard blue flames or wavy yellow flames are not. You can adjust the flame with the air shutter below the control knob (see Fig 19). If yellow flames persist, refer to the Troubleshooting Guide on Page 22.

SHUTTING THE BURNER OFF

1. Turn the control knob counterclockwise to the HIGH position, then depress it and turn it to OFF. **NEVER** force the knob without depressing it, as that can damage the valve.

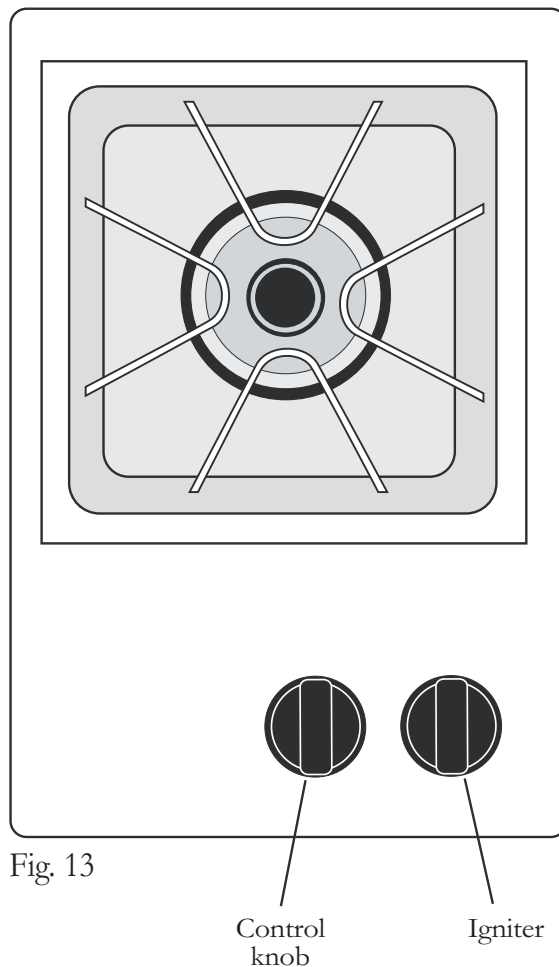

Fig. 13

NOTE: Single burner model shown.

Troubleshooting Guide

PROBLEM	POTENTIAL CAUSE	ACTION REQUIRED
Burner will not light	<p>Gas supply turned off</p> <p>Out of propane</p> <p>Blockage in the gas system</p> <p>Misalignment of the gas valve to the venturi tubes of the burner.</p> <p>Improper attachment of the propane hose and regulator</p>	<p>Turn on fuel supply and retry.</p> <p>Confirm the flow of gas by smell or by listening for the hiss of gas being emitted. Allow gas to clear before attempting to relight.</p> <p>Weigh your propane cylinder. A standard 20 lb. cylinder will weigh about 19 lb. when it is empty and 39 lb. when it is 80 % full.</p> <p>WARNING: Never take a propane cylinder indoors for any purpose.</p> <p>Confirm that the venturi tubes are not blocked by insects or other debris. Use a special venturi brush to clean (Fig. 15).</p> <p>Use a pin or needle to carefully probe the orifice in the gas valve. Never enlarge the orifice (Fig. 16).</p> <p>Look under the front control panel and reinsert the gas injector into the venturi tube, if required (Fig. 22).</p> <p>Tighten the regulator's plastic collar onto the cylinder valve.</p> <p>Hand-tighten only (Fig. 4).</p>
Unit won't heat up (LP)	Control knob left open at startup, or turning gas on too quickly	<p>For safety, the regulator coupling on your barbecue is equipped with a flow control mechanism. This device limits gas flow in the event of a sudden change in the demand for gas. This may be engaged inadvertently, if a burner control knob should be left ON when you open the propane cylinder valve. Rapidly opening the valve can also engage flow control. To resolve the problem, close your cylinder valve. Confirm that all burner control knobs are in the OFF position. Open the cylinder valve slowly (about 1 to 2 turns) and wait 5 seconds. Finally, turn a single burner ON and try relighting it.</p>
Unit won't stay lit	<p>Wind</p> <p>Running out of fuel</p>	<p>Always shelter your Grill from strong winds.</p> <p>Confirm the flow of gas by smell, or by listening for the hiss of gas being emitted.</p> <p>Weigh your propane cylinder. A standard 20 lb. cylinder will weigh about 19 lb. when it is empty and 39 lb. when it is 80% full.</p> <p>WARNING: Never take a propane cylinder indoors for any purpose.</p>

Troubleshooting Guide

PROBLEM	POTENTIAL CAUSE	ACTION REQUIRED
<p>Uneven burn pattern or Flashback fire</p>	<p>Blockage in the burner or gas system</p> <p>Corroded burner</p>	<p>Confirm that the venturi tubes are not blocked by insects or other debris. Use a special venturi brush to clean (Fig. 15).</p> <p>Use a pin or needle to probe the orifice in the gas valve. Never enlarge the orifice (Fig. 16).</p> <p>Use a small nail or toothpick to clean the burner ports (Fig. 16).</p> <p>Corrosion of a gas burner can cause the solid material between the gas ports to deteriorate, resulting in uneven burning. See your retailer for the appropriate replacement burner.</p>
<p>Excessive yellow flame</p>	<p>Improper air shutter opening</p>	<p>Your Grill should burn with a predominantly blue flame. If the flame is mostly yellow, check the venturi tubes for obstruction and clean as shown on Page 19. If yellow flames still persist, adjust the opening on the air shutter of the venturi tube located under the front console of the Grill (Fig. 20).</p>
<p>Flare-up</p>	<p>Excessively fatty foods</p> <p>Grease buildup</p>	<p>Trim all excess fat from meat before cooking.</p> <p>Confirm that the sear plate is clean and properly installed. Remove excess grease from the burn chamber.</p>
<p>Igniter does not spark</p>	<p>Electrode fouled</p> <p>Electrode improperly gapped</p> <p>Electrode cracked</p> <p>Lead wire is disconnected</p> <p>Lead wire is cracked</p> <p>Battery dead or installed wrong</p>	<p>Wipe the electrode with a soft, clean cloth.</p> <p>The electrode should be located 1/8" to 3/16" from the burner, and positioned to spark to the edge of a gas port. If the gap is incorrect, or the unit is not properly sparking, gently bend the electrode tip into position. Use caution so that the ceramic insulator does not crack.</p> <p>If the ceramic insulator on the electrode is cracked, it may short out. Replace the electrode.</p> <p>Confirm that the lead from the Ignitor module to the electrode is well seated on the termination of the module.</p> <p>A crack in the lead wire may result in shorting. Replace the wire.</p> <p>The battery in the Igniter Button may be dead or installed incorrectly. Correct position is positive end down.</p>



VCS4007 / VCS4017 / VCS4027 / VCS4037
VCS5007 / VCS5017 / VCS5027 / VCS5037
ASSEMBLY PROCEDURES

Tools Required: knife or scissors, Phillips or Robertson (square head) screwdriver..

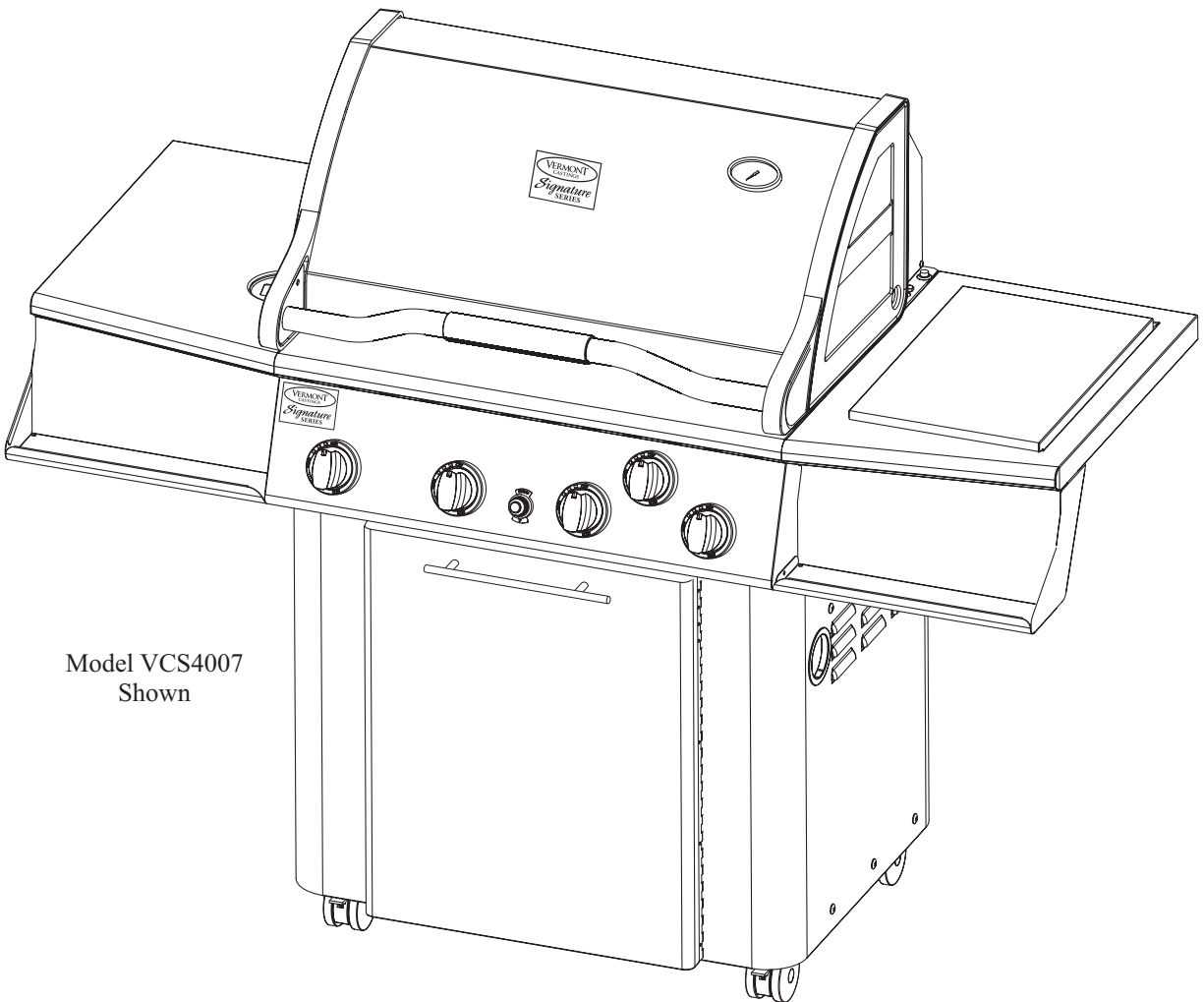

Model VCS4007
Shown

Step 1: Unpack Carton and Verify Contents

Use a sharp cutting tool to cut the straps on the packaging and then lift off the carton top. The sleeve surrounding the barbecue can be removed by lifting it straight up and over the top of the unit. Compare all contents to the parts list that accompanies this assembly manual. Next, remove the protective plastic coverings from the metal parts. Be careful not to scratch or damage the finish of the metal parts when removing the protective plastic. Refer to the parts list for fastener detail.

CAUTION: Some parts may have sharp edges; to avoid injury, wearing gloves during assembly is strongly recommended

Step 2: Install the Casters

Parts Required: (4) Casters, (1) Block (not included)

Note: Casters (wheels) may differ from those shown in the illustration depending on the model you purchased.

Select a side to begin installing the casters. Place a block of wood, a telephone book or anything else available - approximately 6 inches thick - under the side to support the weight of the barbecue. Next, insert the pin on the top of the caster into their respective holes located on the bottom, near the front and rear corners. If you have any difficulty snapping them into place, try rocking the castors in a circular motion. When both casters are in place, repeat the same procedure on the opposite side.

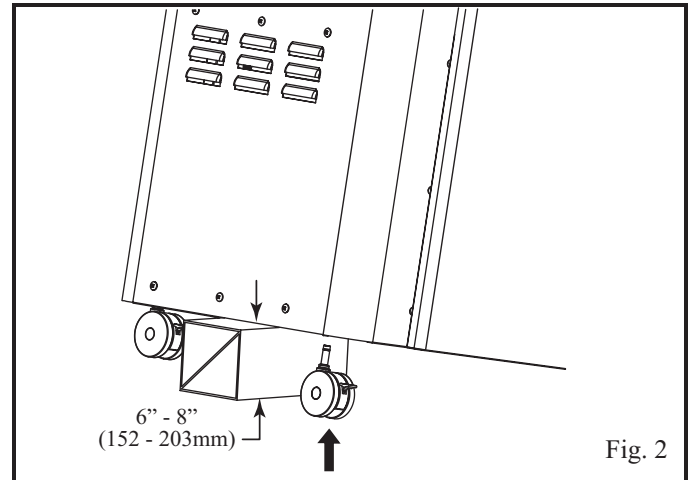

Step 3: Install U-Clip Fasteners

Parts Required:

- (4) #10-20 U-Clip Fasteners
- (1) Left Side Shelf Support, (1) Left Side Shelf
- (1) Right Side Shelf Support, (1) Right Side Shelf

Install the one (1) U-Clip fastener to each of the Side Shelf Supports as shown in Fig. 3a. One (1) U-Clip should be placed on each bracket, with the flat side down.

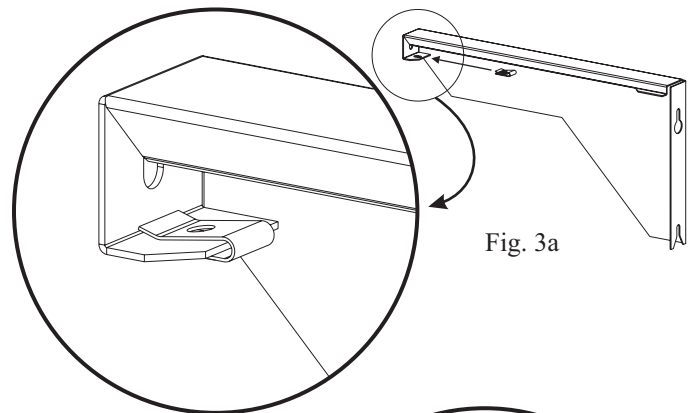

Install the one (1) U-Clip fastener to each of the Side Shelves as shown in Fig. 3b. One (1) U-Clip should be placed on the under side of each shelf, at the front outside corner, with the flat side out.

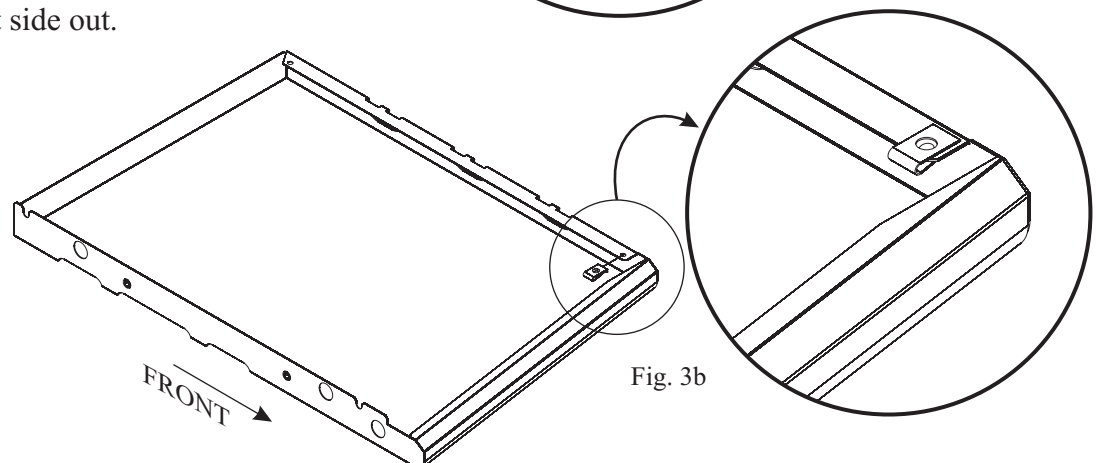

Step 4: Install the Side Shelf Supports

Parts Required:

- (1) Left Side Shelf Support
- (1) Left Condiment Tray
- (1) Right Side Shelf Support
- (1) Right Condiment Tray
- (8) 1/4-20 x 1-1/2" Bolts

Note: Only the right side assembly is shown in Fig. 4a and Fig. 4b. To install Left Side Support and Condiment Tray, repeat this step for the left side.

On the right side of the barbecue there are four threaded inserts, screw a bolt half way into each of the four threaded inserts. You will notice the bottom slot of the support has a 'Y' shaped slot and a 'keyhole' shaped hole above it. Take the Right Side Shelf Support and slide the top screw into the 'keyhole' and the bottom screw into the opening of the 'Y' shaped slot. Now take the Right Condiment Tray and align its holes over the two front bolts and gently push down until the bolts settle into the grooves of the tray.

Next: Gently push down on the support until the screw settles into the top of the groove. Do not fully tighten the support screws at this point.

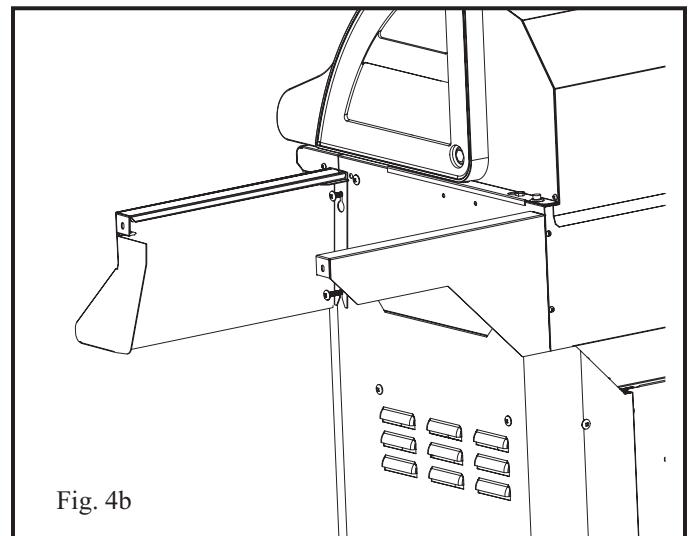
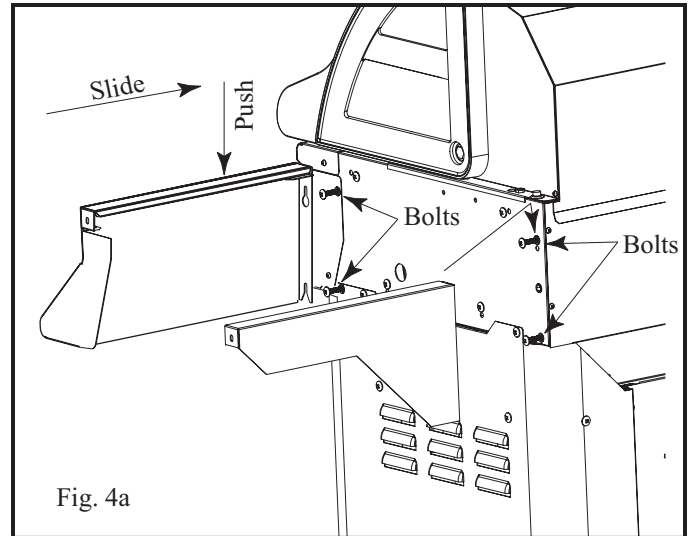

Step 5: Attach Shelves

Parts Required:

- (1) Right Shelf - S/B (Shown)
- (1) Left Shelf - Solid

Place the Right Shelf - S/B (shown) on top of the supports making sure the holes are aligned and then snap into place on the supports. The inside lip of the shelf will slide between the grill shell and the shelf supports.

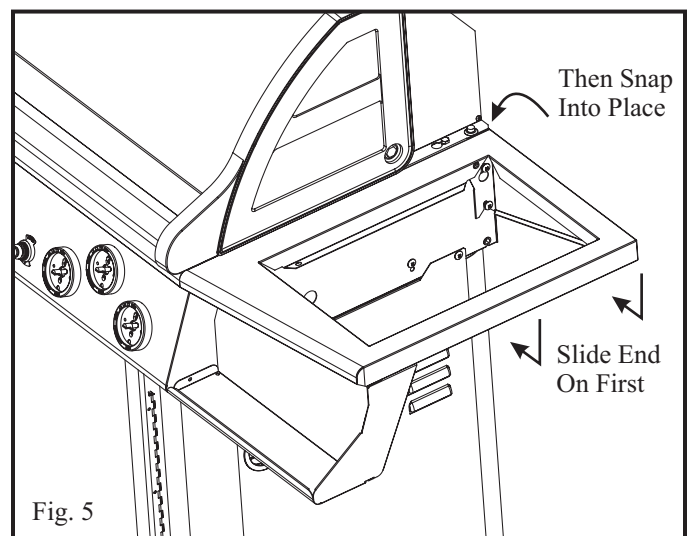

Step 6: Secure Shelves

Parts Required:

(4) 10-24 x 1/2" Bolts (black)

A. Secure each Shelf by inserting (2) 10-24 x 1/2" bolts through the U-Clip fasteners as shown in the diagram.

B. Tighten the four (4) Shelf Support bolts from Step 4 to secure the shelf supports to the grill body.

Repeat Steps 5 & 6 for the opposite side of the grill.

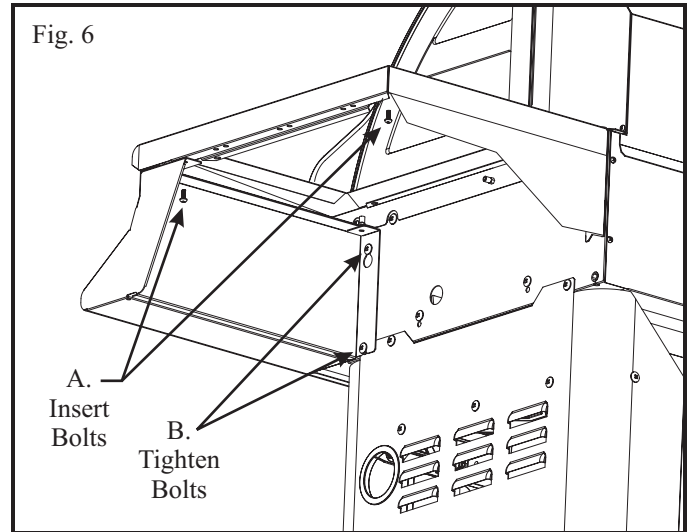

Step 7: Secure Side Shelf to Grill

Parts Required:

(3) 10-24 x 1/2" Bolts (black)

Lift the grill lid and insert two (2) #10-24 x 1/2" bolts, shown as "a" and "b" in Fig. 7, to further secure the Shelf Right - S/B to the grill body. Be sure to fully tighten the bolts before proceeding to the next step.

Next: Repeat Step 7 on the opposite side of the grill's interior to secure the Shelf Left - Solid to the grill body by inserting only one (1) #10-24 x 1/2" bolt in the "b" location as shown in the illustration.

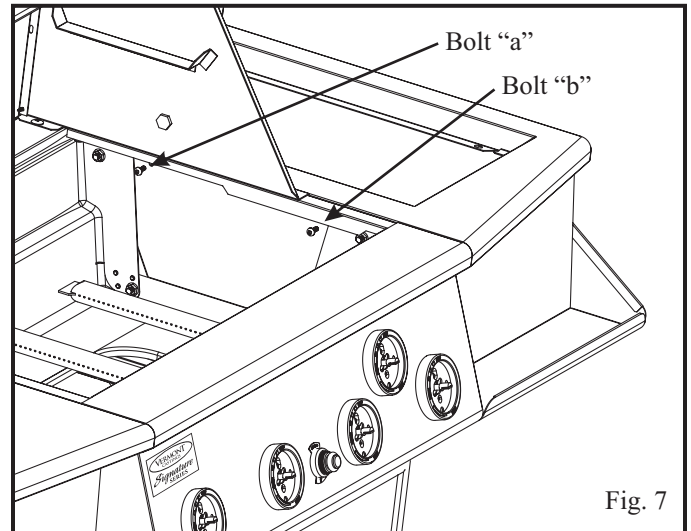

Step 8: Secure Condiment Tray to Console

Parts Required:

(2) #10-24 x 1/2" Bolts (stainless)

(2) #10-24 Nuts (black)

Secure the Left Condiment Tray to the Console using a #10-24 x 1/2" stainless bolt and a #10-24 nut. Make sure the holes of the Condiment Tray and the Console are aligned. Reach underneath the console and hold the nut in place with one finger and insert the bolt from the outside as shown in Fig. 8 and tighten until they are securely fastened.

Next: Repeat Step 5 to secure the Right Condiment Tray to the opposite side of the console.

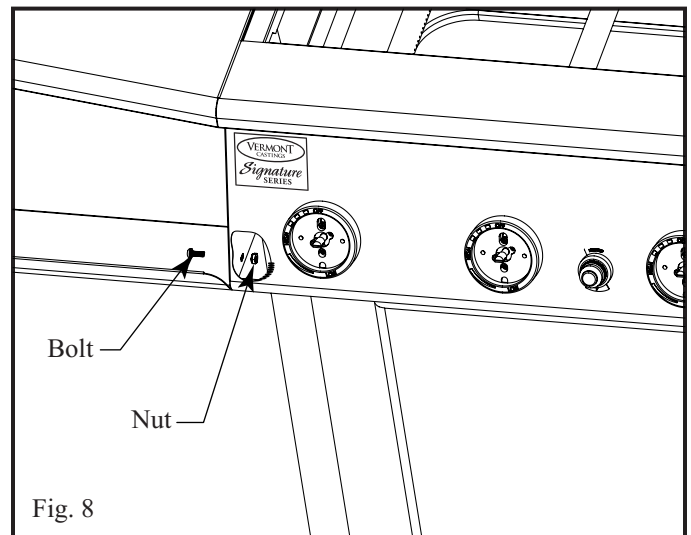

Step 9: Attach Side Burner Lid (S/B-Single)

Parts Required:

- (1) Side Burner Lid (S/B-Single)
- (2) #10-24 x 3/4" (1/4" Shank)*

* Included with the Side Burner Kit

Attach the lid marked (S/B-Single) to the Shelf Right top marked VM-S/B using two #10-24 x 3/4" (1/4" Shank) bolts. Align the holes at the back sides of the lid with the holes located in the shelf top and insert a bolt in each.

Note: If your unit is equipped with a side burner, please refer to the instruction sheet included with the side burner for installation instructions.

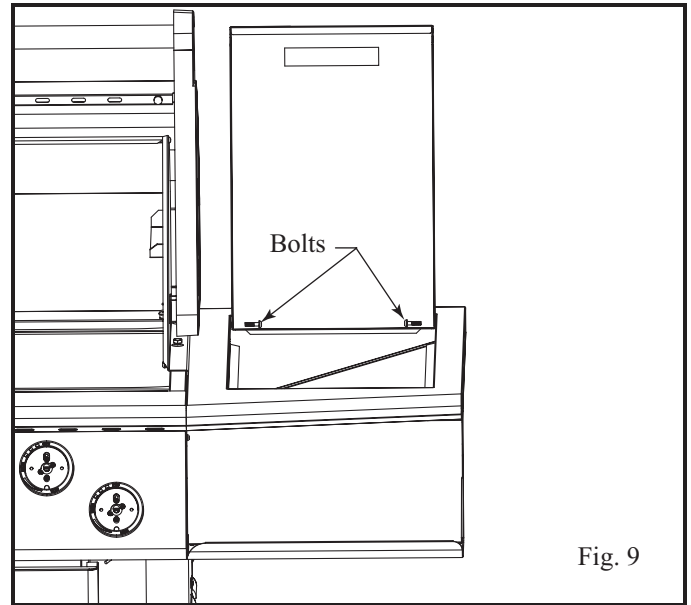

Fig. 9

Step 10: Attach Knobs

Parts Required:

- | | |
|--------------------|--------------------|
| VCS4007: (5) Knobs | VCS5007: (6) Knobs |
| VCS4017: (5) Knobs | VCS5017: (6) Knobs |
| VCS4027: (5) Knobs | VCS5027: (6) Knobs |
| VCS4037: (5) Knobs | VCS5037: (6) Knobs |

Note: Depending upon your specific model, your grill may require 5 or 6 knobs. Models VCS4007, VCS4017, VCS4027, & VCS4037 are equipped with five (5) knobs, and models VCS5007, VCS5017, VCS5027 & VCS5037 are equipped with six (6) knobs.

Align the knobs on the valve stems and push inward until the knob sits snugly on the stem.

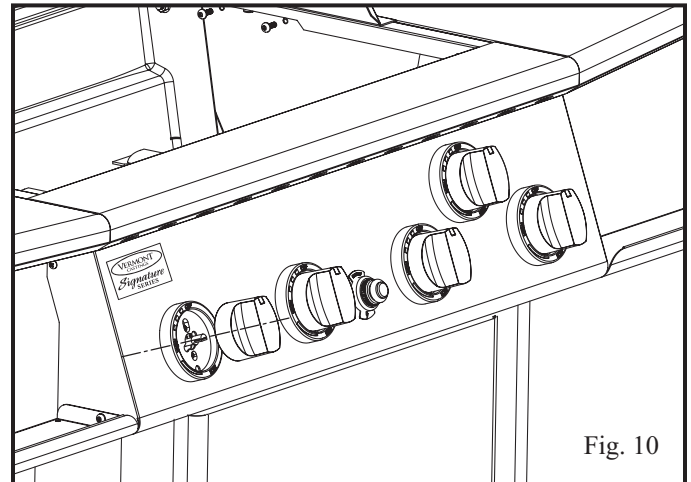

Fig. 10

Step 11: Remove the Packing Tape

Remove the Packing Tape from:

- The Grease Cup
- The Base Assembly (inside the grill)
- The Warming Rack

Note: For models VCS5007, VCS5017, VCS5027 & VCS5037, remove the Packing Tape from the front pull-out drawer.

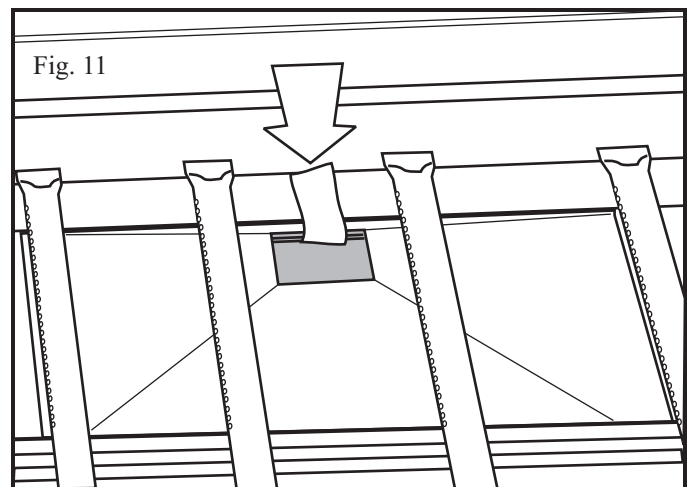

Fig. 11

Step 12: Attach the Handle to the Door

Parts Required:

VCS4007/VCS4017/VCS4027/VCS4037: (1) Handle
 VCS5007/VCS5017/VCS5027/VCS5037: (3) Handles

Note: Handles may not appear exactly as shown in diagram

Attach the Door handle(s) to the door(s) by aligning the handles over the holes and inserting the screws that were supplied with the handles through the door panel and into the handles. For models VCS5007, VCS5017, VCS5027 & VCS5037, attach the drawer handle using the same method.

Note: If doors are not aligned or have shifted during shipping, they can be adjusted by loosening the screws which fasten the hinge of the door to the grill body and shifting the doors until they are aligned. Once satisfied with alignment, fully tighten the screws to secure the doors into position.

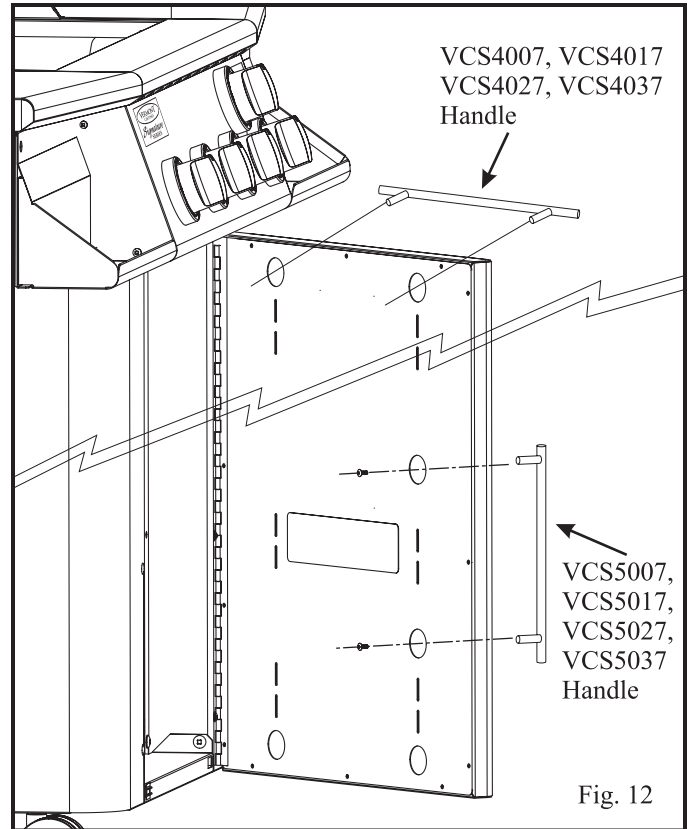

Fig. 12

Step 13: Install the Grease Cup and Grease Pan

Parts Required:

- (1) Grease Cup
- (1) Grease Pan

Install the Grease Cup into the cut-out in the Upper Base Panel located underneath the grill. It is accessible from the back of the grill. Once the Grease cup is in place, move the Grease pan into position above it by placing the side edges onto the support rails and sliding it into place.

Note: Make sure the funnel opening of the grease pan is positioned over the Grease Cup.

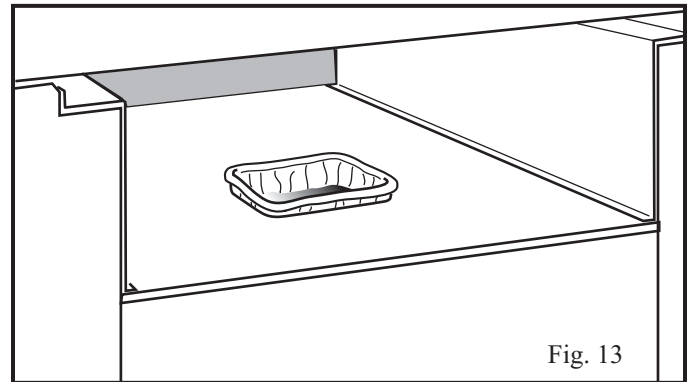

Fig. 13

Step 14: Attach Stabilizer Bracket

Parts Required:

- (2) #10-24 x 1/2" Bolts (black)
- (1) Stabilizer Bracket

Attach the Stabilizer Bracket underneath the bottom panel by aligning the holes and inserting both #10-24 x 1/2" bolts through the panel and into the Stabilizer Bracket as shown in Fig. 14.

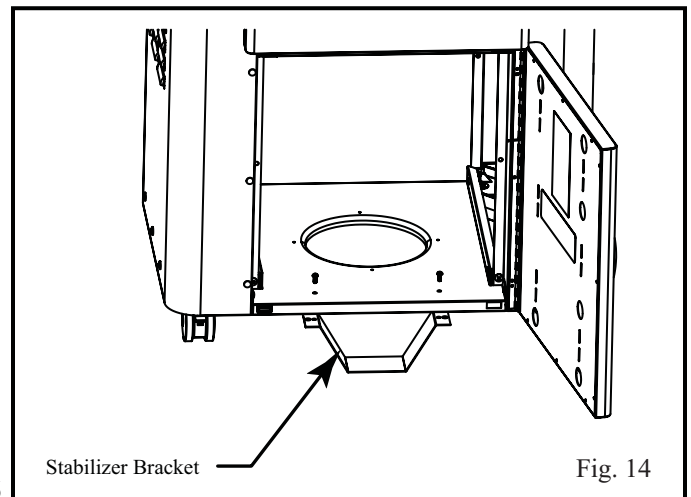

Fig. 14

Step 15: Install the Internal Components

Parts Required:

VCS4007 / VCS4017 :	(4) Sear Plates
VCS4027 / VCS4037	(3) Cooking Grates
	(1) Warming Rack
VCS5007 / VCS5017 :	(5) Sear Plates
VCS5027 / VCS5037	(4) Cooking Grates
	(1) Warming Rack

Carefully place each of the Sear plates side by side inside the barbecue, making sure the semicircular finger groove is facing toward the front of the grill. Each sear plate rests just above each burner tube.

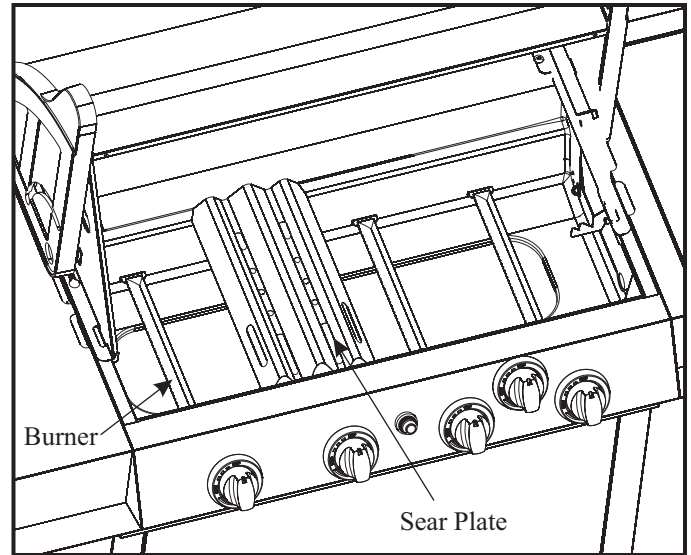

Fig. 15a

Next, set the cooking grates, side by side, on the upper ledge of the grill tub. Make sure the finger groove is facing toward the front of the grill.

Set the warming rack into the supports located on either side of the rear lid.

Note: One side of the Grate surface has a rounded side suitable for meats and a flat side suitable for delicate foods (i.e. fish). Grates can be turned over according to your preference.

Caution: Do not attempt to turn Cooking Grate over while the Grill is in use and grates are hot. Doing so could result in severe burns and other injuries.

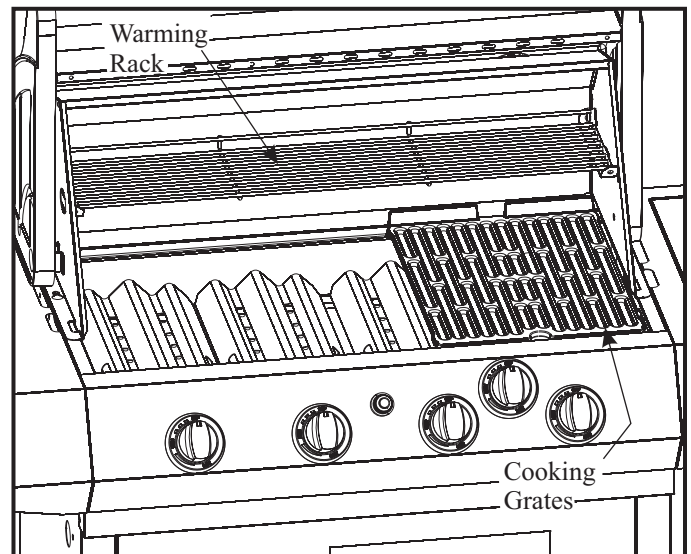
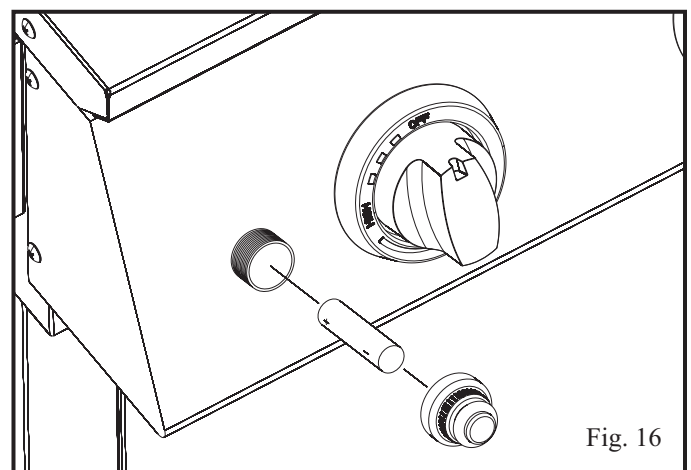

Fig. 15b

Step 16: Install the Battery

Note: requires a "AA" Battery.

Unscrew the Ignition Button from the console and insert a battery into the housing by placing the positive side of the battery in first. Then screw the Ignition button back into the console.



Step 17: Install the LP Cylinder (LP Models Only)

Parts Required:

(1) LP Gas Cylinder (not included)

Note: Check your user's manual for the cylinder filling requirements, how to attach the regulator and how to test for leaks before you try lighting the grill.

Caution: Make sure the hose is not touching any hot surfaces.

Note: For Models VCS5007, VCS5017, VCS5027 & VCS5037, refer to Tank Pull-out assembly instructions included with the Tank Pull-out kit.

Place the LP Cylinder into the hole in the bottom panel. Next secure it from moving by lifting the Cylinder retainer wire and latching the bent edge over the lip of the Cylinder. The final step is to connect the Regulator to the Cylinder.

Caution: Do not turn on the grill until after performing a leak check at all connection points and fittings. Use a spray solution of 50% dish soap and 50% water onto all connection points and fittings. Formation of bubbles indicates air leaks.

Note: Ensure all plastic coatings have been removed from all stainless steel parts before using the grill.

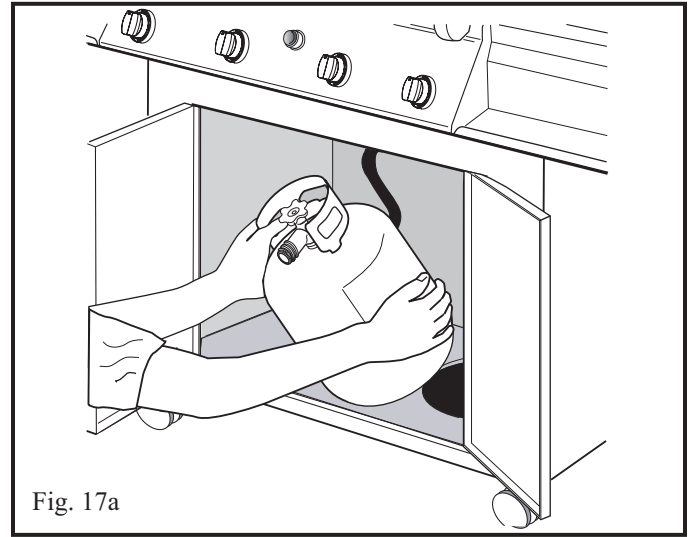

Fig. 17a

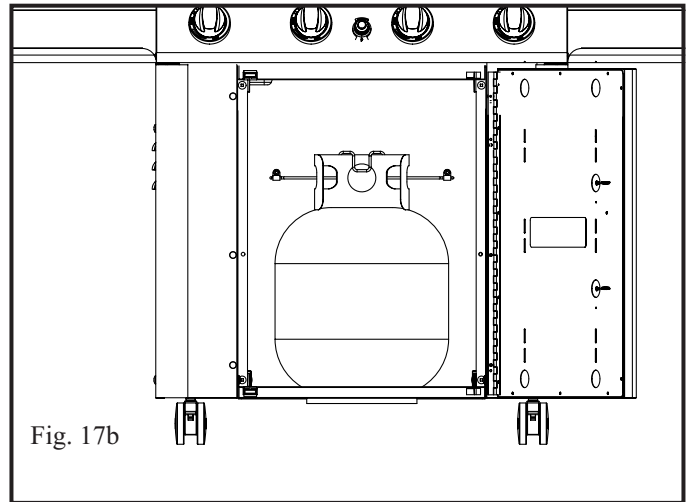

Fig. 17b



CFM
CFM Corporation
410 Admiral Boulevard
Mississauga, Ontario L5T 2N6 Canada
(800) 668-5323

www.cfmcorp.com

Service Note: If you are experiencing difficulties or are dissatisfied with your purchase, please contact CFM at the telephone number listed above prior to returning your grill to the store.



www.cfmcorp.com

Service Note: If you are experiencing difficulties or are dissatisfied with your purchase, please contact CFM at the telephone number listed above prior to returning your grill to the store.