

Outdoor LP Gas Barbecue Grill

Model No. NPG2322SS

WARNING
FOR YOUR SAFETY:

For Outdoor Use Only
(outside any enclosure)

WARNING
FOR YOUR SAFETY:

1. Improper installation, adjustment, alteration, service or maintenance can cause injury or property damage.
2. Read the installation, operation, and maintenance instructions thoroughly before installing or servicing this equipment.
3. Failure to follow these instructions could result in fire or explosion, which could cause property damage, personal injury, or death.
4. This instruction manual contains important information necessary for the proper assembly and safe use of the appliance.
5. Read and follow all warnings and instructions before assembling and using the appliance.
6. Follow all warnings and instructions when using the appliance.
7. Keep this manual for future reference.

DANGER

If you smell gas -

1. Shut off gas to appliance.
2. Extinguish any open flame.
3. Open lid.
4. If odor continues, keep away from the appliance and immediately call your fire department.

Failure to follow these instructions could result in fire or explosion which could cause property damage, personal injury or death.

WARNING
FOR YOUR SAFETY:

1. Do not store or use gasoline or other flammable liquids or vapors in the vicinity of this or any other appliance.
2. An LP cylinder not connected for use shall not be stored in the vicinity of this or any other appliance.

DANGER

Never operate this appliance unattended.

Save these instructions for future reference. If you are assembling this unit for someone else, give this manual to him or her to read and save for future reference.

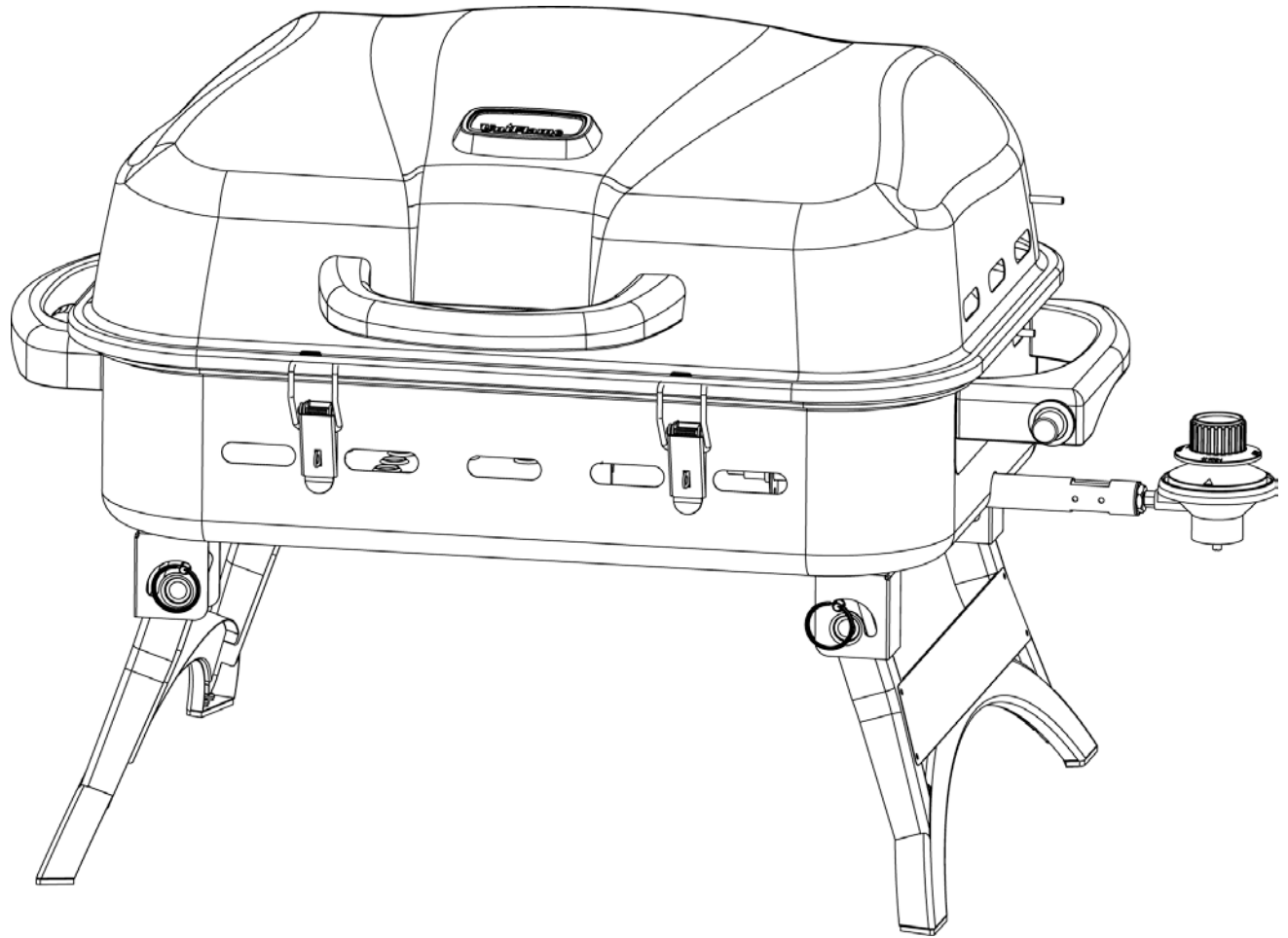

Table of Contents

Important Safeguards	Page 2
Exploded View & Hardware	3
Assembly Instructions	4
Operating Instructions	7
Connect LP Gas Tank	7
Disconnect LP Gas Tank	7
Checking for Leaks	7
First Use	7
Lighting Instructions	7
Turning Off	7
Cooking	7
Controlling Flare-ups	7
Tips	8
Cleaning and Care	8
Product Registration	8
Limited Warranty	8
Troubleshooting	9

The use and installation must conform with local codes or, in the absence of local codes, with either the *National Fuel Gas Code, ANSI Z223.1/NFPA 54, Natural Gas and Propane Installation Code, CSA B149.1, or Propane Storage and Handling Code, B149.2, or the Standard for Recreational Vehicles, ANSI A 119.2/NFPA 1192, and CSA Z240 RV Series, Recreational Vehicle Code, as applicable.*

California Proposition 65: Combustion by-products produced when using this product contain chemicals known to the State of California to cause cancer, birth defects, and other reproductive harm.

California Proposition 65: Wash your hands after handling this product.

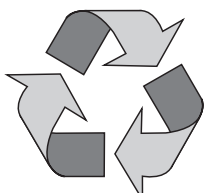

Made from 75% Bagasse
(Environmentally Friendly Sugar
Cane Pulp By-product)





▲ DANGER: Failure to follow the dangers, warning and cautions in this manual may result in serious bodily injury or death, or in a fire or an explosion causing damage to property.

▲ WARNING:

- ▲ This grill is for outdoor use only and shall not be used in a building, garage or any other enclosed area.
- ▲ This grill is not intended for and should never be used as a heater. TOXIC fumes can accumulate and cause asphyxiation.
- ▲ This grill is NOT for commercial use.
- ▲ This is not a tabletop grill. Therefore, do not operate this grill on any type of tabletop surface.
- ▲ This grill is safety certified for use in the United States and Canada only. Do not modify for use in any other location. Modification will result in a safety hazard and will void warranty.
- ▲ Do NOT operate, light or use this appliance within ten (10) feet (3.05 m) of walls, structures or buildings.
- ▲ Apartment Dwellers: Check with management to learn the requirements and fire codes for using an LP gas grill in your apartment complex. If allowed, use outside on the ground floor with a ten (10) foot (3.05 m) clearance from any structure. Do not use on or under balconies.
- ▲ This grill is for use with liquid propane (LP) gas only. The conversion to or attempted use of natural gas in this LP gas grill is dangerous and will void your warranty.
- ▲ LP gas characteristics:
 - a. LP gas is flammable and hazardous if handled improperly. Become aware of the characteristics before using any LP gas product.
 - b. LP gas is explosive under pressure, heavier than air and settles and pools in low areas.
 - c. LP gas in its natural state has no odor. For your safety, an odorant is added that smells like rotten cabbage.
 - d. Contact with LP gas can cause freeze burns to skin.
- ▲ Only tanks marked “propane” may be used with this appliance.
- ▲ The LP gas tank must be constructed and marked in accordance with the *Specifications for LP gas Cylinders of the U.S. Department of Transportation (DOT) or the National Standard of Canada, CAN/CSA-B339, Cylinders, Spheres and Tubes for the Transportation of Dangerous Goods; and Commission.*
- ▲ LP gas tank must be arranged for vapor withdrawal.
- ▲ Dented or rusted LP gas tanks may be hazardous and should be checked by your LP gas supplier prior to use.
- ▲ The LP gas tank should not be dropped or handled roughly.
- ▲ LP gas tanks must be stored outdoors out of the reach of children and must not be stored in a building, garage, or any other enclosed area. Your tank must never be stored where temperatures can reach over 125°F.
- ▲ Do not insert any tool or foreign object into the valve outlet or safety relief valve. You may damage the valve and cause a leak. Leaking propane may result in explosion, fire, severe personal injury or death.
- ▲ Do not block holes in sides, back or bottom of grill.
- ▲ Never attempt to attach this grill to the self-contained LP gas system of a camper trailer, motor home or house.
- ▲ Do not store a spare LP gas tank under or within 25 feet (7.62 m) of this appliance.
- ▲ The use of alcohol, prescription or non-prescription drugs may impair the consumer’s ability to properly assemble or safely operate the appliance.
- ▲ Strong odors, colds, sinus congestion, etc. may prevent the detection of propane. Use caution and common sense when testing for leaks.
- ▲ Never use charcoal, lighter fluid, lava rocks, gasoline, kerosene or alcohol with this product.
- ▲ Your grill has been checked at all factory connections for leaks. Recheck all connections as described in the “Operating Instructions” section of the manual, as movement in shipping can loosen connections.
- ▲ Check for leaks even if your unit was assembled for you by someone else.
- ▲ Do not operate if gas leak is present. Gas leaks may cause a fire or explosion.
- ▲ You must follow all leak-checking procedures before operating. To prevent fire or explosion hazard when testing for a leak:
 - a. Always perform leak test before lighting the grill and each time the tank is connected for use.
 - b. Do not use or permit sources of ignition in the area while conducting a leak test. No smoking.
 - c. Conduct the leak test outdoors in a well-ventilated area.
 - d. Do not use matches, lighters or a flame to check for leaks.
 - e. Do not use grill until any and all leaks are corrected.If you are unable to stop a leak disconnect the LP gas supply. Call our customer care at 1.800.762.1142, a gas appliance serviceman or your local LP gas supplier.
- ▲ Do not use in an explosive atmosphere. Keep grill area clear and free from combustible materials, gasoline and other flammable vapors and liquids.
- ▲ Minimum clearance from sides and back of unit to combustible construction is 36 inches (91.4 cm). Do not use this appliance under any type of overhang or roof.
- ▲ It is essential to keep the grill’s valve compartment, burners, and circulating air passages clean. Inspect grill before each use.
- ▲ Do not use the grill unless it is COMPLETELY assembled and all parts are securely fastened and tightened.
- ▲ This grill should be thoroughly cleaned and inspected on a regular basis.
- ▲ Do not alter grill in any manner. Any alteration will void your warranty.
- ▲ Use only the regulator provided. Any replacement regulator shall be specified by the manufacturer.
- ▲ Use only Blue Rhino Global Sourcing, Inc. factory authorized parts. The use of any part that is not factory authorized can be dangerous. This will also void your warranty.
- ▲ Do not attempt to repair or alter the hose/regulator for any “assumed” defect. Any modification to this assembly will void your warranty and create the risk of a gas leak and fire. Use only authorized replacement parts supplied by manufacturer.
- ▲ Do not use this appliance without reading “Operating Instructions” in this manual.
- ▲ Do not touch metal parts of grill until it has completely cooled (about 45 min.) to avoid burns, unless you are wearing protective gear (pot holders, gloves, BBQ mittens, etc.).
- ▲ Do not install or use in or on boats or recreational vehicles.
- ▲ Do not use grill in a vehicle trunk, station wagon, mini-van, sport utility vehicle (SUV) or recreational vehicle (RV).
- ▲ When cooking fire extinguishing materials shall be readily accessible. In the event of an oil/grease fire, do not attempt to extinguish with water. Use type BC dry chemical fire extinguisher or smother with dirt, sand or baking soda.
- ▲ Move gas hoses as far away as possible from hot surfaces and dripping hot grease.
- ▲ Do not use grill in high winds.
- ▲ Never lean over grill when lighting.
- ▲ Do not leave a lit grill unattended. Keep children and pets away from grill at all times.
- ▲ Do not leave grill unattended while preheating or burning off food residue on HIGH. If grill has not been cleaned, a grease fire can occur that may damage the product.
- ▲ Do not place empty cooking vessels on the appliance while in operation.
- ▲ Use caution when placing anything on the grill while the appliance is in operation.
- ▲ Do not attempt to move grill when in use. Allow the grill to cool (approximately 45 minutes) before moving or storing.
- ▲ Storage of grill indoors is permissible only if the tank is disconnected, removed from the grill and properly stored outdoors.
- ▲ Always open grill lid carefully and slowly as heat and steam trapped within grill can severely burn you.
- ▲ Do not attempt to disconnect the gas regulator from the tank or any gas fitting while the grill is in use.
- ▲ Disconnect LP gas tank when not in use.
- ▲ Always use your grill on a hard, non-combustible level surface. An asphalt or blacktop surface may not be acceptable for this purpose.
- ▲ Do not use directly on wooden decks.
- ▲ Keep all electrical cords away from a hot grill.
- ▲ Do not use grill for indoor cooking or heating. TOXIC fumes can accumulate and cause asphyxiation.
- ▲ After a period of storage and/or nonuse check for leaks and burner obstructions.
- ▲ Failure to open lid while igniting the grill’s burner, or not waiting 5 minutes to allow the gas to clear if the grill does not light, may result in an explosive flame-up.
- ▲ Never operate grill without heat plate installed.
- ▲ Always use a meat thermometer to ensure food is cooked to a safe temperature.
- ▲ Use protective gloves when assembling this product.
- ▲ Do not force parts together as this can result in personal injury or damage to the product.
- ▲ Never cover entire cooking area with aluminum foil.
- ▲ Death, serious injury or damage to property may occur if the above is not followed exactly.

Contact 1.800.762.1142 for assistance. Do not return to place of purchase.
For great recipes and tips, visit recipes.uniflame.com

Parts List

1	Lid Handle	55-10-366
2	Temperature Gauge	55-10-040
3	Lid	55-11-507
4	Warming Rack	55-11-508
5	Cooking Grid	55-511-509
6	Top Hinge (2)	55-10-372
7	Bottom Hinge (2)	55-14-653
8	Left Side Handle	55-10-373
9	Heat Plate Support (2)	55-09-330
10	Side Handle Heat Shield (2)	55-11-510
11	Bottom Bowl	55-11-511
12	Right Side Handle	55-10-376
13	Regulator/Control Knob	55-11-210
14	Heat Plate	55-11-512
15	Burner	55-11-513
16	Igniter Wire*	55-11-514
17	Lock (2)*	55-11-515
18	Bowl Heat Shield	55-11-516
19	Left Leg	55-11-517
20	Right Leg	55-111-518

* Pre assembled

Exploded View

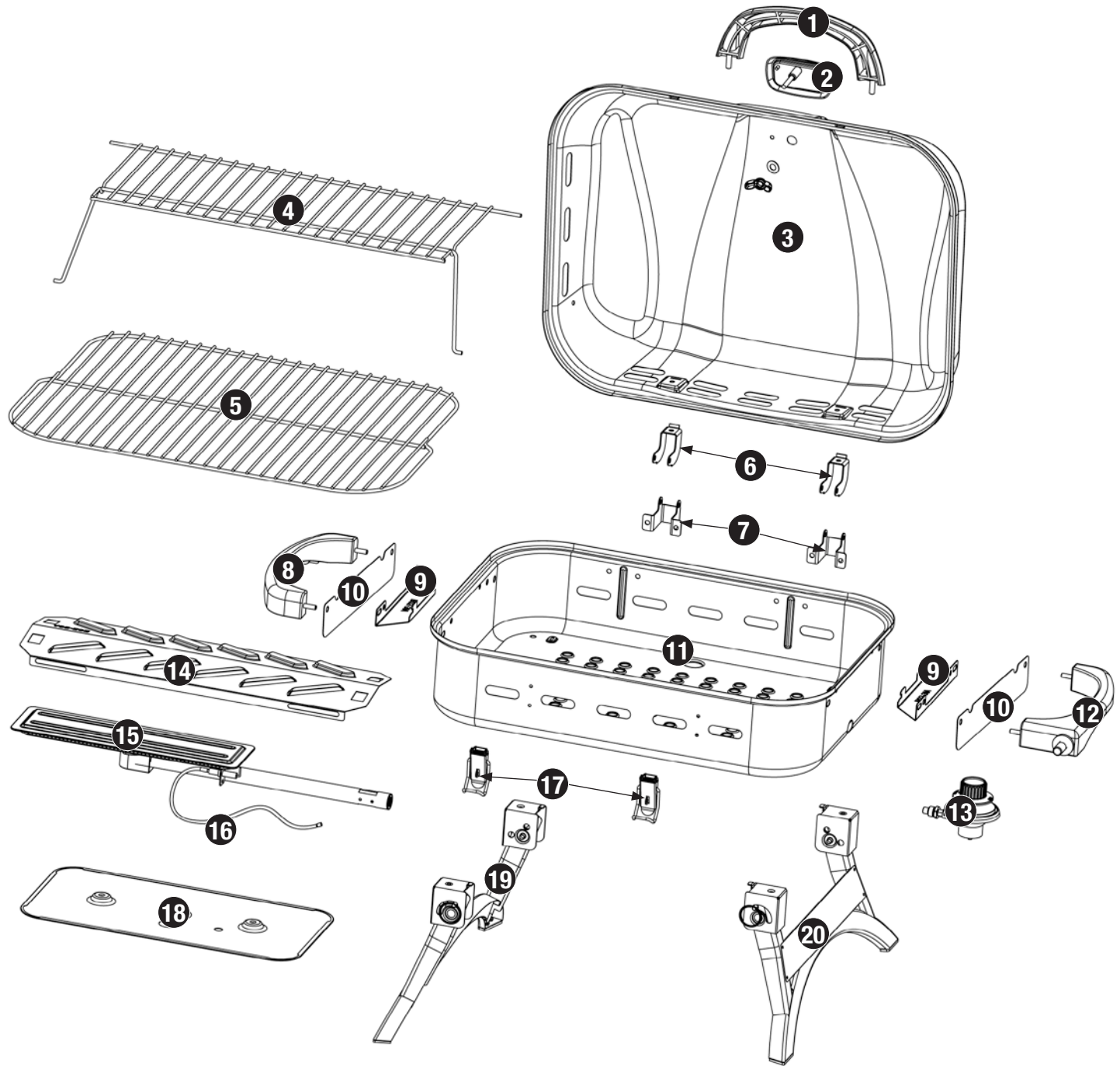

Hardware

A	Screw	M5x12 Zinc Plated Phillips Truss Head	8 pcs
B	Screw	M6x12 Zinc Plated Phillips Truss Head	8 pcs
C	Wing Bolt	M6x8 Zinc Plated	1 pc
D	Wing Nut	M5 Steel	8 pcs
E	Wing Nut	M6 Steel	10 pcs
F	Washer	ø5 Zinc Plated	6 pcs
G	Washer	ø6 Zinc Plated	11 pcs
H	Washer	ø6 Heat Resistant	8 pcs
I	Lock Washer	ø5 Zinc Plated	6 pcs
J	Lock Washer	ø6 Zinc Plated	11 pcs
K	Pin	ø5 x 30 Zincl Pated	2 pcs
L	Cotter Pin	ø1.4 x 30 Zincl Pated	2 pcs

Tools Required for Assembly (Included)

#2 Phillips Head Screwdriver 1 pc

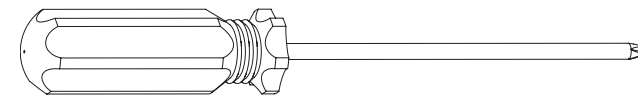

Assembly Instructions

1 DO NOT RETURN PRODUCT TO STORE.

For assistance call **1.800.762.1142** toll free. Please have your owner's manual and model number available for reference.

Note: The model number can be found on the back or side of the grill.

For Easiest Assembly:

- To avoid losing any small components or hardware, assemble your product on a hard level surface that does not have cracks or openings.
- Clear an area large enough to layout all components and hardware.
- When applicable, tighten all hardware connections by hand first. Once the step is completed go back and fully tighten all hardware.
- Follow all steps in order to properly assemble your product.

To complete assembly you will need:

- (1) Leak Detection Solution (Instructions on how to make solution are included in "Operating Instructions" section)
- (1) 14.1 oz or (1) 16.4 oz LP gas tank.

Typical assembly: approximately 30 minutes.

2 Attach Temperature Gauge, Top Hinges and Lid Handle

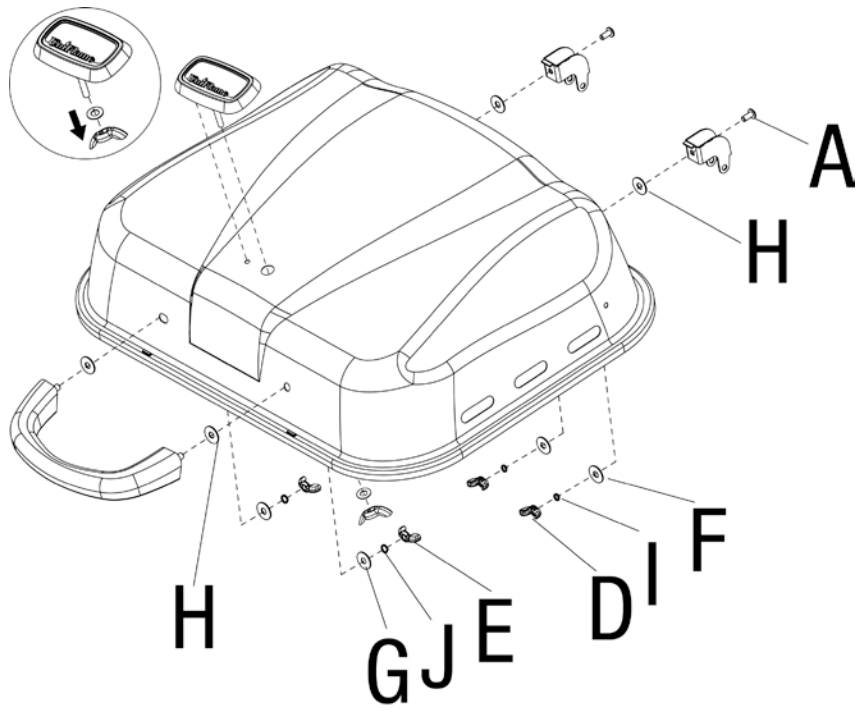

- | | | | |
|---|-----|---|-----|
| A | x 2 | G | x 2 |
| D | x 2 | H | x 4 |
| E | x 2 | I | x 2 |
| F | x 2 | J | x 2 |

3 Attach Bottom Hinges

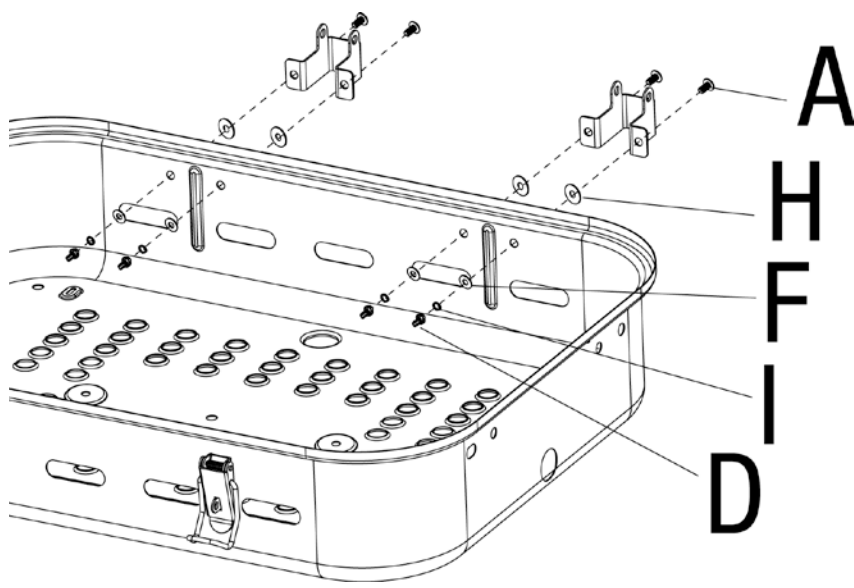

- | | | | |
|---|-----|---|-----|
| A | x 4 | H | x 4 |
| D | x 4 | I | x 4 |
| F | x 4 | | |

4 Attach Side Handle Heat Shields, Heat Plate Supports and Left and Right Side Handles

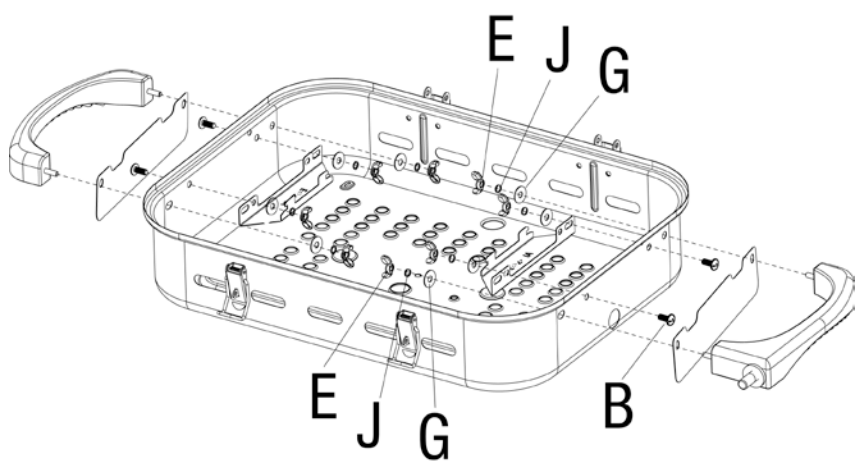

- | | | | |
|---|-----|---|-----|
| B | x 4 | G | x 8 |
| E | x 8 | J | x 8 |

5

Attach Legs

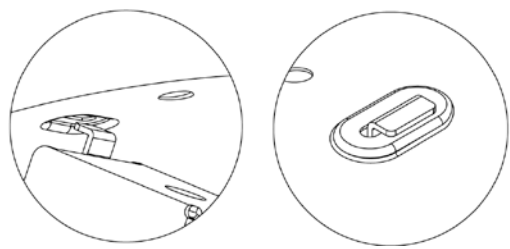
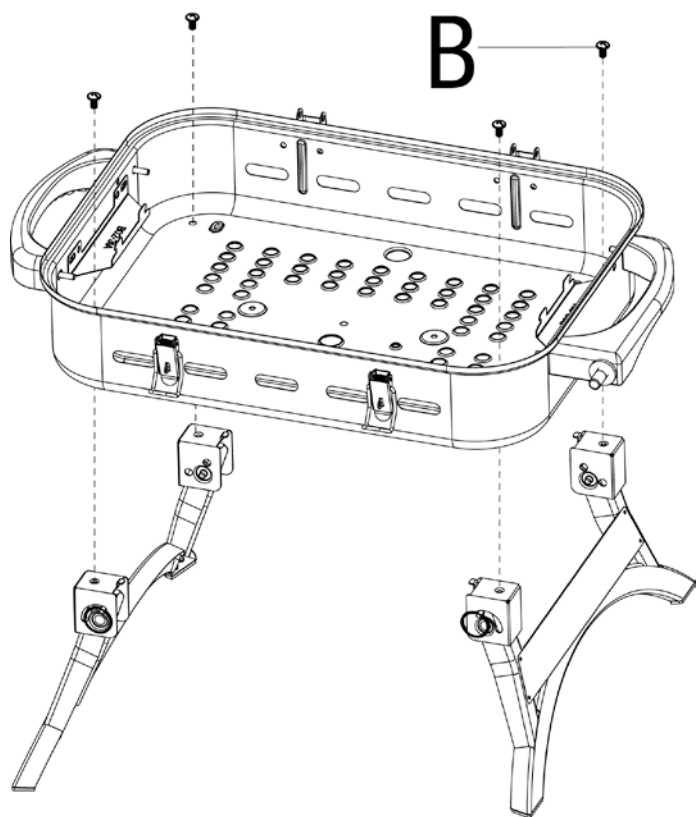

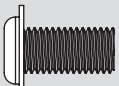
B  x 4

6

Attach Burner, Bowl Heat Shield, Regulator/Control Knob and Igniter Wire

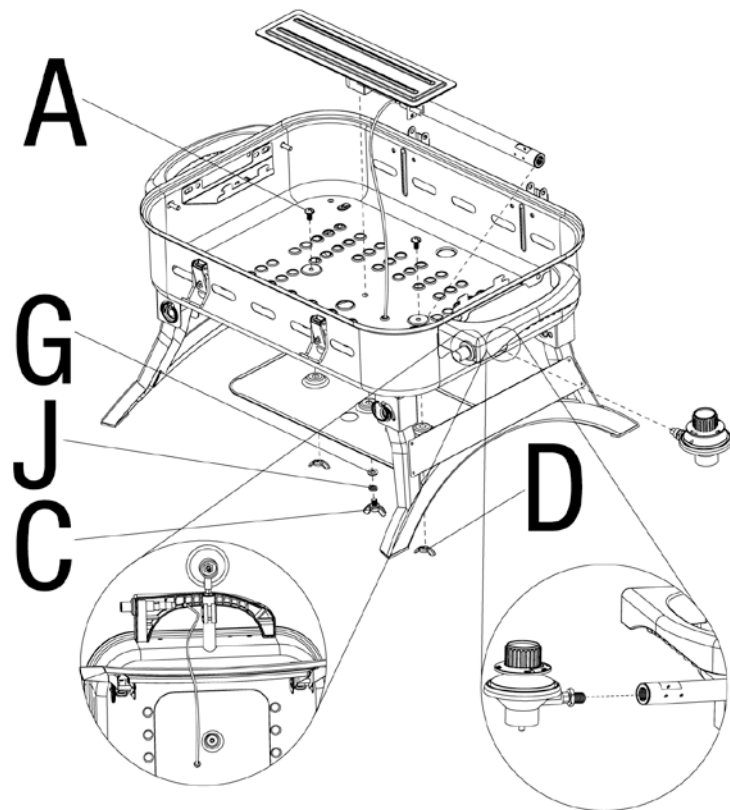

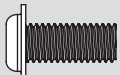
A  x 2

D  x 2

G  x 1

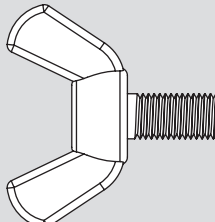
C  x 1

J  x 2

7

Attach Lid

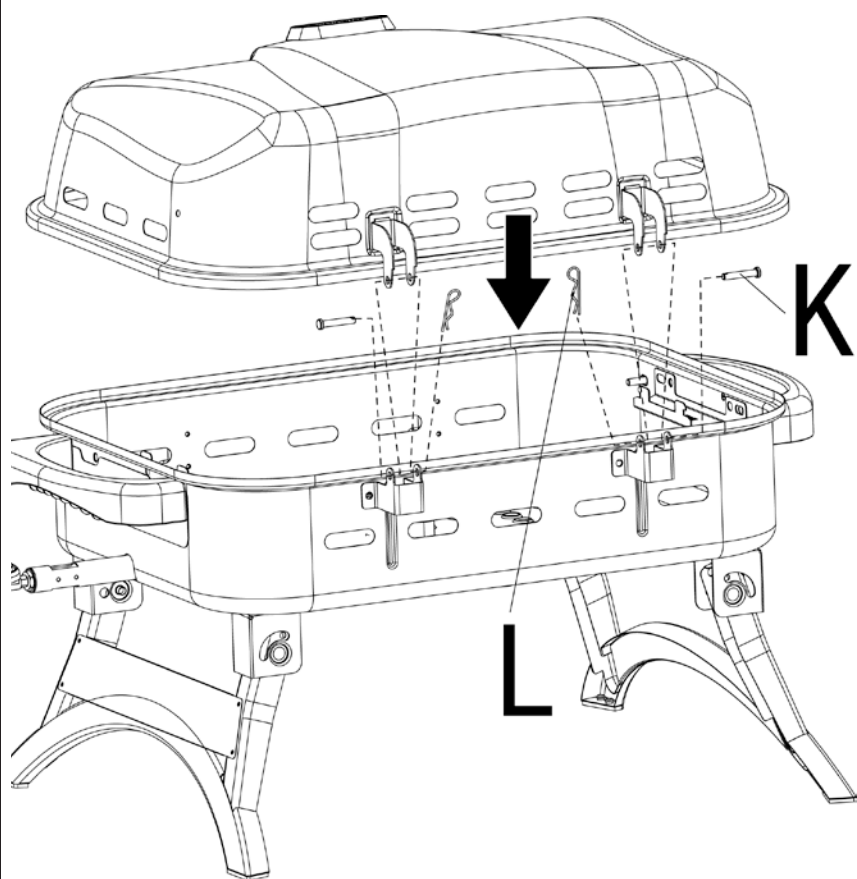

K  x 2

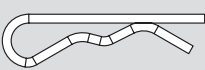
L  x 2

8

Insert Warming Rack

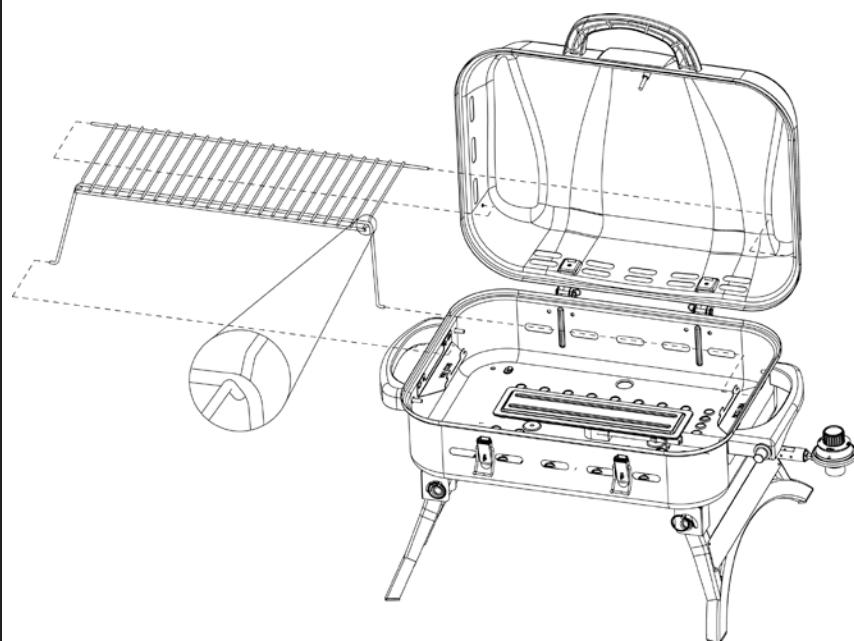

Assembly Instructions (continued)

9

Attach Heat Plate and Cooking Grid

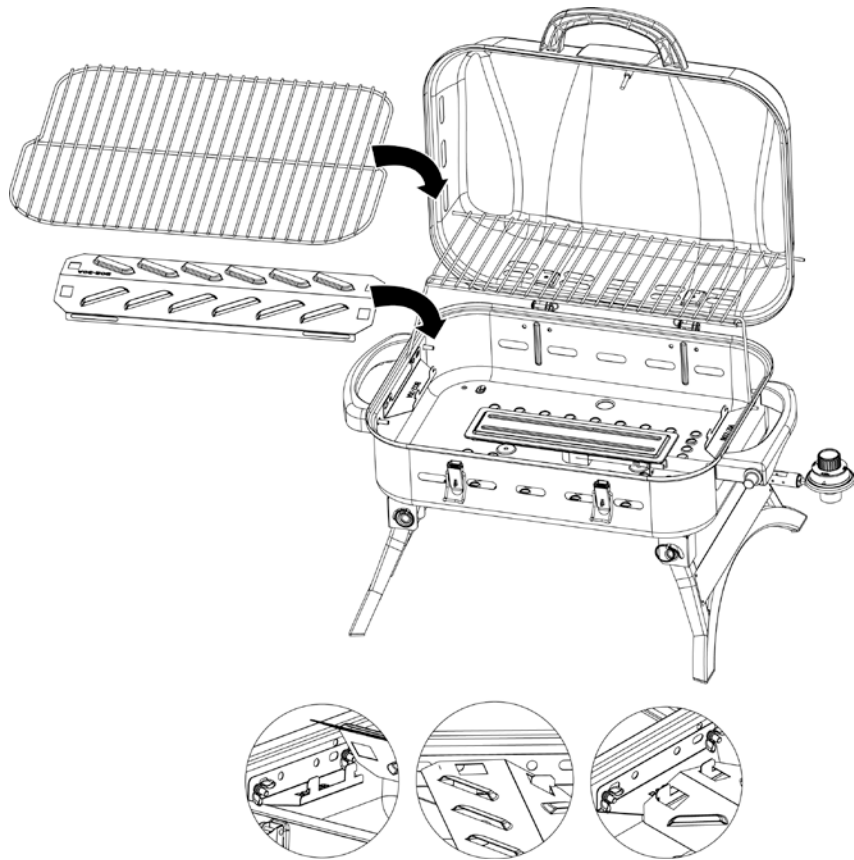

10

Locking Lid

Note: Lid must be locked before transporting.

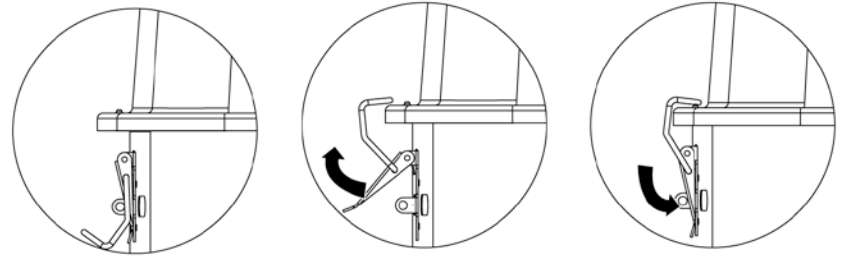

Unlocking Lid

Note: Always unlock and open lid before lighting.

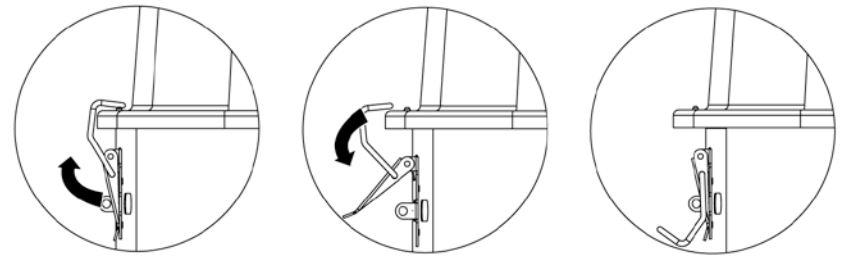

11

Fold Up Legs

Note: Always lock lid before folding legs.

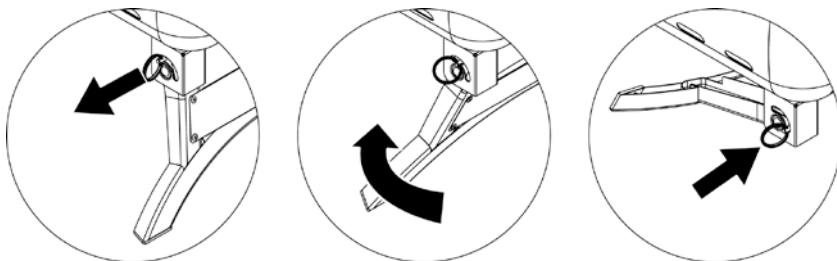

Unfold Legs

Note: Always open legs completely and are secured in place before lighting.

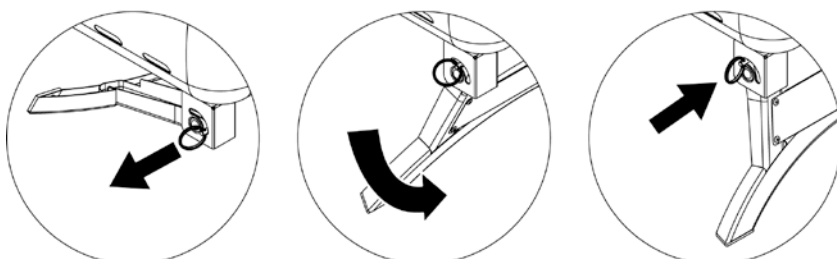

Contact 1.800.762.1142 for assistance. Do not return to place of purchase.
For great recipes and tips, visit recipes.uniflame.com

Operating Instructions

This grill is designed to operate with a one pound 7.75" or 10.6" high disposable / 16.4 oz. or 14.1 oz. propane gas tank (DOT 39 Cylinder). (Figure 1)

DO NOT ATTEMPT TO REFILL ANY ONE POUND (16.4 oz. or 14.1 oz.) PROPANE GAS TANKS!

Connect LP Gas Tank

Only cylinders marked "propane" may be used.

Note: Some 1-lb cylinders may form frost when near empty.

1. Make sure the regulator/control knob is in the "OFF" position. (Figure 2)
2. Lubricate the threads of the regulator/control knob with petroleum jelly. Line up threads on LP gas tank with regulator/control knob.
3. Insert and rotate LP gas tank clockwise until they fit snugly together. **HAND TIGHTEN ONLY.** Be careful not to cross threads when screwing in canister. (Figure 3)
4. Test for leaks, see "Checking for Leaks" section.

Disconnect LP Gas Tank

1. Turn the regulator/control knob to the "OFF" position. (Figure 2)
2. Rotate LP gas tank counterclockwise until it is loose. (Figure 4)
3. Store the LP gas tank in a proper location, per LP gas tank instructions.

Checking for Leaks

Burner Connections

1. Make sure the regulator/control knob is securely fastened to the burner.
Note: The brass nut should be 1/4 to 1/2 turn past tight. The regulator will rotate 360° even when the brass nut is tightened.

If your unit was assembled for you, visually check the connection between the burner and regulator/control knob. (Figure 4)

WARNING: Failure to inspect this connection or follow these instructions could cause a fire or an explosion which can cause death, serious bodily injury, or damage to property.

2. If the burner and regulator/control knob do not fit properly or if you have any questions please contact 1.800.762.1142 for assistance.

Tank/Gas Line Connection

1. Make 2-3 oz. of leak solution by mixing one part liquid dishwashing soap with three parts water.
2. Make sure regulator/control knob is in the "OFF" position. (Figure 2)
3. Spoon several drops of solution, or use squirt bottle, at all "X" locations. (Figure 5)
 - a. If any bubbles appear remove the LP gas tank and reconnect, making sure the connection is secure.
 - b. If you continue to see bubbles after several attempts, remove the LP gas tank per "Disconnect LP Gas Tank" instructions, and contact 1.800.762.1142 for assistance.
 - c. If no bubbles appear after one minute, wipe away solution and proceed.

First Use

1. Make sure all labels, packaging and protective films have been removed from the grill.
2. Remove manufacturing oils before cooking on this grill for the first time by operating the grill for at least 15 minutes on (HIGH) with the lid closed. This will "heat clean" the internal parts and dissipate odors.

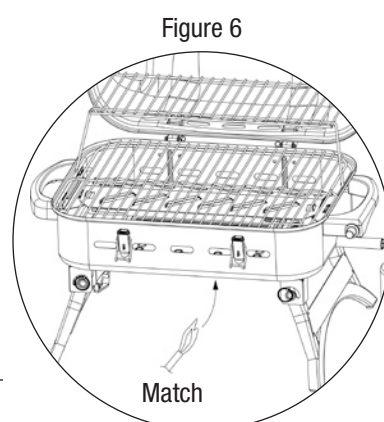
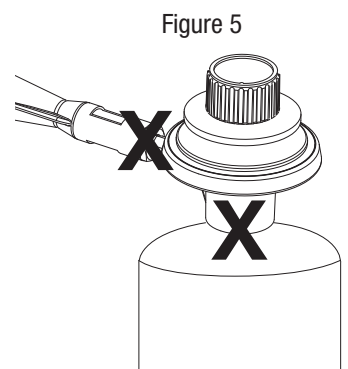
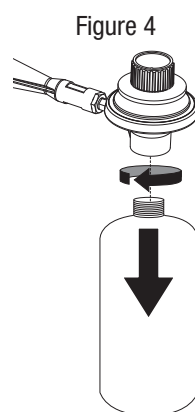
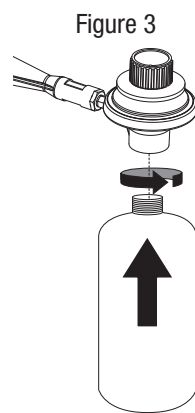
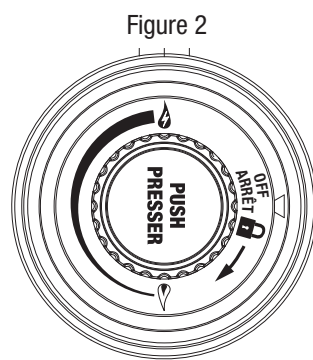
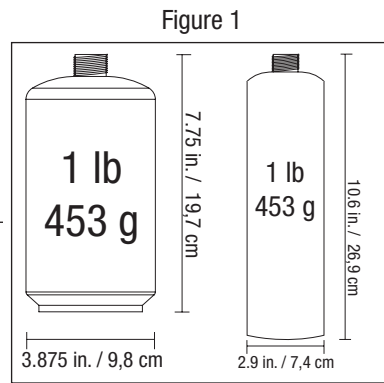

Lighting Instructions

Caution: Keep outdoor gas cooking appliance area clear and free from combustible materials, gasoline and other flammable vapors and liquids.

Caution: Do not obstruct the flow of combustion and ventilation air.

Caution: Check and clean burner/venturi tubes for insects and insect nests. A clogged tube can lead to a fire beneath the grill.

Caution: Attempting to light the burner with the lid closed may cause an explosion.

1. Make sure all labels, packaging and protective films have been removed from the grill.
 2. Open lid during lighting.
 3. Make sure there are no obstructions of airflow to the gas unit. Spiders and insects can nest within and clog the burner / venturi tube at the orifice.
 4. Connect LP gas tank per "Connect LP Gas Tank" instructions.
 5. The regulator/control knob must be in the "OFF" position. (Figure 2)
 6. Turn the control knob to (HIGH).
 7. Press the Igniter button repeatedly (3 to 4 times) to light burner.
 8. If ignition does not occur in 5 seconds, turn regulator/control knob to "OFF" position, wait 5 minutes and repeat lighting procedure.
 9. If igniter does not light burner, use a lit match to light burner manually. Access the burner through the hole in bottom bowl as indicated. (Figure 6)
 10. Turn the regulator/control knob to (LOW) and position the lit match near side of the burner.
 11. After lighting, observe the burner flame. Make sure all burner ports are lit and flame height matches illustration. (Figure 7)
- Caution: If burner flame goes out during operation, immediately turn the regulator/control knob "OFF" and open lid to let the gas clear for 5 minutes before re-lighting.**

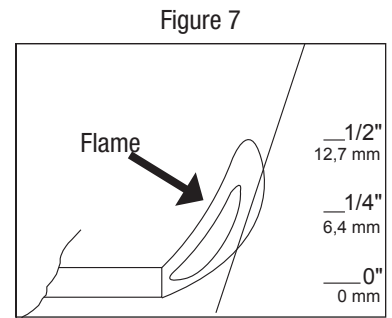

Turning Off

1. Turn regulator/control knob to the "OFF" position. (Figure 2)
2. Disconnect LP gas tank per "Disconnect LP Gas Tank" instructions and properly store tank.

Cooking

Caution: Do not leave grill unattended while preheating or burning off food residue on (HIGH). If grill has not been cleaned, a grease fire can occur.

1. Open lid and ignite burner per "Lighting Instructions".
2. Close lid and preheat grill on (HIGH).
3. Adjust regulator/control knob to desired temperature.
4. Wearing protective gloves lift lid by handle(s) and use long handle tongs to place food onto cooking grids above the lit burners.
5. With lid open or closed, cook until desired internal food temperatures are achieved.
6. Turn grill "OFF" by turning regulator/control knob to the "OFF" position. Remove LP gas tank, per "Disconnect LP Gas Tank" instructions, and properly store tank.

Controlling Flare-ups

Caution: Putting out grease fires by closing the lid is not possible.

- Do not use water on a grease fire. This can cause the grease to splatter and could result in serious burns, bodily harm or other damage. If a grease fire develops, turn regulator/control knob "OFF".

- Do not leave grill unattended while preheating or burning off food residue on (HIGH). If grill has not been cleaned, a grease fire can occur that may damage the product.

WARNING: When cooking, fire extinguishing materials shall be readily accessible. In the event of an oil/grease fire, do not attempt to extinguish with water. Use type BC dry chemical fire extinguisher or smother with dirt, sand or baking soda.

Flare-ups are a part of cooking meats on a grill, and adds to the unique flavor of grilling.

Excessive flare-ups can over cook your food and cause a dangerous situation for you and your grill.

Important: Excessive flare-ups result from the build-up of grease in the bottom of your grill. If excessive flare-ups occur, **DO NOT** pour water onto the flames.

If grease fire occurs, close the lid AND turn the regulator/control knob to "OFF", until the grease burns out. Use caution when opening the lid as sudden flare-ups may occur.



Operating Instructions (continued)

Tips for Better Cookouts and Longer Grill Life

1. For great recipes and tips, visit recipes.uniflame.com
2. For food safety tips visit: http://www.fsis.usda.gov/Fact_Sheets/Barbecue_Food_Safety/
3. Use the upper cooking grid (warming rack) for keeping cooked food warm, toasting breads or cooking delicate foods in aluminum foil pouches.
4. Use the side burner of this appliance like a normal kitchen range for boiling, sautéing or frying.
5. To keep food from sticking to the grids, spray or coat with cooking oil before lighting.
6. To reduce flare-up keep grill clean, use lean cuts of meat (or trim fat) and avoid cooking on very high temperatures.
7. Place delicate foods like fish and vegetables in aluminum foil pouches and indirect cook or place on upper cooking levels (warming rack).
▲ WARNING: Never cover entire cooking area with aluminum foil.
8. To avoid losing natural juices, use long handled tongs or spatulas instead of forks and turn foods over just once during cooking.
9. When direct cooking adjust your burners to different levels so foods can be prepared to different internal temperatures in the same time frame.
10. When indirect cooking roasts and larger cuts of meat, place meat onto a roasting rack inside a heavy gauge metal pan. Place pan over the un-lit burners.
11. Try water pans to reduce flare-ups and cook juicer meats. Before starting grill remove cooking grids and place a heavy duty shallow pan directly on heat plates. Fill half way with water, fruit juices or other flavored liquids. Replace cooking grids and position food over the loaded pan.
12. Enhance food flavors by using wood chips in smoker boxes or aluminum foil pouches. Follow the wood manufacturer's instructions.
13. Rotisseries, grill baskets, vertical poultry holders and other accessories can enhance your experiences, reduce cooking times and aid in clean-up.
14. Clean cooking grids and racks after every use with a quality grill brush designed for your grid material. Wear protective gloves and gently remove the build-up while grids are hot.
15. After every use, allow grill to cool. Then protect clean cooking grids with a light coat of cooking oil, empty grease pan, wipe outside surfaces with a suitable kitchen cleaner and protect surfaces with a quality cover that properly fits your grill.
16. Watch barbecue themed TV shows or purchase related barbecue cookbooks to learn more interesting tips like –
A gas grill is ideal for reheating leftover pizza. Set burners on low and place pizza slices directly on preheated cooking grid. Close lid and cook until cheese starts to bubble.

Cleaning and Care

▲ Caution:

1. All cleaning and maintenance should be done when grill is completely cool and with the LP gas tank disconnected.
2. DO NOT clean any grill part in a self cleaning oven. The extreme heat will damage the finish.

Notices

1. Abrasive cleaners will damage this product.
2. Never use oven cleaner to clean any part of grill.

Cleaning Surfaces

1. Turn regulator/control knob to “OFF 🔒” and remove LP gas tank, per “Disconnect LP Gas Tank” instructions. Wait for grill to fully cool (about 45 min.).
2. Wipe surfaces clean with mild dishwashing detergent or baking soda.
3. For stubborn surfaces use a citrus based degreaser and a nylon scrubbing brush.
4. Rinse clean with water.

Cleaning Burner

1. Turn regulator/control knob to “OFF 🔒” and remove LP gas tank, per “Disconnect LP Gas Tank” instructions. Wait for grill to fully cool (about 45 min.).
2. Remove regulator/control knob and wind guard.
3. Remove cooking grid and heat plate.
4. Disconnect wire from igniter, if applicable.
5. Remove burner.
6. Remove all food residue and dirt on burner surface.
7. Clean inlet of burner with small bottle brush or compressed air.
8. Clean any clogged ports with a stiff wire (such as an opened paper clip)
9. Inspect burner for any damage (cracks or holes). If damage is found, replace with new burner from manufacturer.
10. Reinstall burner. Reconnect igniter (if applicable), wind guard and regulator/control knob.
11. Replace heat plate and cooking grid.
12. Connect the LP gas tank per “Connect LP Gas Tank” instructions.
13. Perform leak test.

Cleaning and Care (continued)

Before Storing

1. Turn regulator/control knob to “OFF 🔒” and remove LP gas tank, per “Disconnect LP Gas Tank” instructions.
2. Clean all surfaces.
3. Lightly coat the burners with cooking oil to prevent excess rusting.
4. If storing the grill indoors, disconnect the LP gas tank, see “Disconnect LP Gas Tank” instructions, and leave the LP gas tank OUTDOORS.
5. Place the protective cap cover on the LP tank and store the tank outdoors in a well ventilated area out of direct sunlight.
6. If storing the grill outdoors, cover the grill with a grill cover for protection from the weather.

Product Registration

For faster warranty service, register your product immediately at www.bluerhino.com or call 1.800.762.1142.

Limited Warranty

Blue Rhino Global Sourcing, Inc (“Vendor”) warrants to the original retail purchaser of this product, and to no other person, that if this product is assembled and operated in accordance with the printed instructions accompanying it, then for a period of one (1) year from the date of purchase, all parts in such product shall be free from defects in material and workmanship. Vendor may require reasonable proof of your date of purchase. Therefore, you should retain your sales slip or invoice. This Limited Warranty shall be limited to the repair or replacement of parts, which prove defective under normal use and service and which Vendor shall determine in its reasonable discretion upon examination to be defective. Before returning any parts, you should contact Vendor's Customer Service Department using the contact information listed below. If Vendor confirms, after examination, a defect covered by this Limited Warranty in any returned part, and if Vendor approves the claim, Vendor will replace such defective part without charge. If you return defective parts, transportation charges must be prepaid by you. Vendor will return replacement parts to the original retail purchaser, freight or postage prepaid.

This Limited Warranty does not cover any failures or operating difficulties due to accident, abuse, misuse, alteration, misapplication, improper installation or improper maintenance or service by you or any third party, or failure to perform normal and routine maintenance on the product as set out in this owner's manual. In addition, the Limited Warranty does not cover damage to the finish, such as scratches, dents, discoloration, rust or other weather damage, after purchase.





This Limited Warranty is in lieu of all other express warranties. Vendor disclaims all warranties for products that are purchased from sellers other than authorized retailers or distributors, including the warranty of merchantability or the warranty of fitness for a particular purpose. VENDOR ALSO DISCLAIMS ANY AND ALL IMPLIED WARRANTIES, INCLUDING WITHOUT LIMITATION THE IMPLIED WARRANTIES OF MERCHANTABILITY AND FITNESS FOR A PARTICULAR PURPOSE. VENDOR SHALL HAVE NO LIABILITY TO PURCHASER OR ANY THIRD PARTY FOR ANY SPECIAL, INDIRECT, PUNITIVE, INCIDENTAL, OR CONSEQUENTIAL DAMAGES. Vendor further disclaims any implied or express warranty of, and assumes no responsibility for, defects in workmanship caused by third parties.

This Limited Warranty gives the purchaser specific legal rights; a purchaser may have other rights depending upon where he or she lives. Some jurisdictions do not allow the exclusion or limitation of special, incidental or consequential damages, or limitations on how long a warranty lasts, so the above exclusion and limitations may not apply to everyone.

Vendor does not authorize any person or company to assume for it any other obligation or liability in connection with the sale, installation, use, removal, return, or replacement of its equipment, and no such representations are binding on Vendor.

Blue Rhino Global Sourcing, Inc
Winston-Salem, North Carolina USA
(800) 762-1142

Troubleshooting

Problem	Possible Cause	Prevention/Cure
Burner will not light using ignitor (if included)	LP gas tank is low or empty	Replace LP gas tank
	LP gas leak	Follow "Checking for Leaks" instructions in the owner's manual
	Wires or electrode covered with cooking residue	Clean wire and/or electrode with rubbing alcohol
	Electrode and burners are wet	Wipe dry with cloth
	Electrode cracked or broken - sparks at crack	Replace electrode, please call our Customer Care at 1.800.762.1142
	Wire loose or disconnected	Reconnect wire or replace electrode/wire assembly, please call our Customer Care at 1.800.762.1142
	Wire is shorting (sparking) between ignitor and electrode	Replace ignitor wire/electrode assembly, please call our Customer Care at 1.800.762.1142
	Bad ignitor	Replace ignitor, please call our Customer Care at 1.800.762.1142
Burner will not light with match	No gas flow	Check if LP gas tank is empty A. If empty, replace B. If LP gas tank is not empty, refer to "Sudden drop in gas flow or reduced flame height"
	LP gas tank is low or empty	Replace LP gas tank
	LP gas leak	Follow "Checking for Leaks" instructions in the owner's manual
	Coupling nut and regulator not fully connected	Turning the coupling nut about one-half to three quarters additional turn until solid stop. Tighten by hand only-do not use tools
	Obstruction of gas flow	Clear burner tubes, per cleaning instruction on www.bluerhino.com
	Spider webs or insect nest in venturi	Clean venturi and burner tube, per cleaning instruction on www.bluerhino.com
	Burner ports clogged or blocked	Clean burner ports, per cleaning instruction on www.bluerhino.com
Sudden drop in gas flow or reduced flame height	Out of gas	Replace LP gas tank
	Excess flow valve tripped; safety device may have been activated	1. Turn regulator/control knob to "OFF  2. Wait 30 seconds and light grill 3. If flames are still too low, reset the excessive flow safety device: a. Turn regulator/control knob "OFF  b. Remove LP gas tank c. Wait 1 minute d. Attach LP gas tank e. Perform a leak check per "Checking for Leaks" instructions in the owner's manual f. Light grill per "Lighting Instructions" instructions in the owner's manual
Irregular flame pattern, flame does not run the full length of burner	Burner ports are clogged or blocked	Clean burner ports, per cleaning instruction on www.bluerhino.com
Flame is yellow or orange	New burner may have residual manufacturing oils	Burn grill for 15 minutes on  (HIGH) with the lid closed
	Spider webs or insect nest in venturi	Clean venturi, per cleaning instruction on www.bluerhino.com
	Food residue, grease, etc.	Clean burner, per cleaning instruction on www.bluerhino.com
	Poor alignment of valve to burner venturi	Assure burner venturi is properly engaged with valve
Flame blow out	High or gusting winds	Do not use grill in high winds
	Low on LP gas	Replace LP gas tank
	Excess flow valve tripped; safety device may have been activated	Refer to "Sudden drop in gas flow or reduced flame height"
Flare-up	Grease buildup	Remove and clean all grill parts per "Cleaning and Care" instructions in the owner's manual
	Excess fat in meat	Trim fat from meat before grilling
	Excessive cooking temperature	Adjust (lower) cooking temperature
Persistent grease fire	Grease trapped by food buildup around burner system	1. Turn control knob to "OFF  2. Leave lid in closed position and let fire burn out 3. After grill cools, remove and clean all parts per "Cleaning and Care" instructions in the owner's manual
Flashback (fire in burner tube(s))	Burner and/or burner tubes are blocked	Clean burner and/or burner tube, per cleaning instruction on www.bluerhino.com
Inside of lid is peeling (like paint peeling)	The lid is stainless steel, not painted	Baked on grease buildup has turned to carbon and is flaking off, clean thoroughly per "Cleaning and Care" instructions in the owner's manual
	The lid is coated/painted	This can be from baked on grease buildup, that has turned into carbon and is flaking off. Clean thoroughly, per "Cleaning and Care" instructions in the owner's manual After cleaning, if you can see steel, please call out Customer Care at 1.800.762.1142

For more assistance please visit us online at www.bluerhino.com or call 1.800.762.1142.



