

grilling perfection **Aussie** *inspired design*
Vantage

LP Gas Grill Assembly and Use Manual

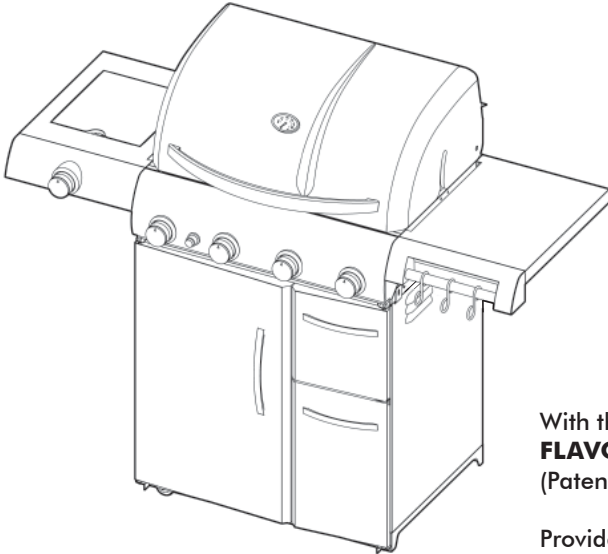

6804T80SS1

With the **NEW Aussie FLAVOR ACTIVATOR SYSTEM**
(Patent Pending)

Provides:

- More even heat on the cooking surface
- Hotter temperature with the same fuel usage
- Longer cooking for the same amount of fuel

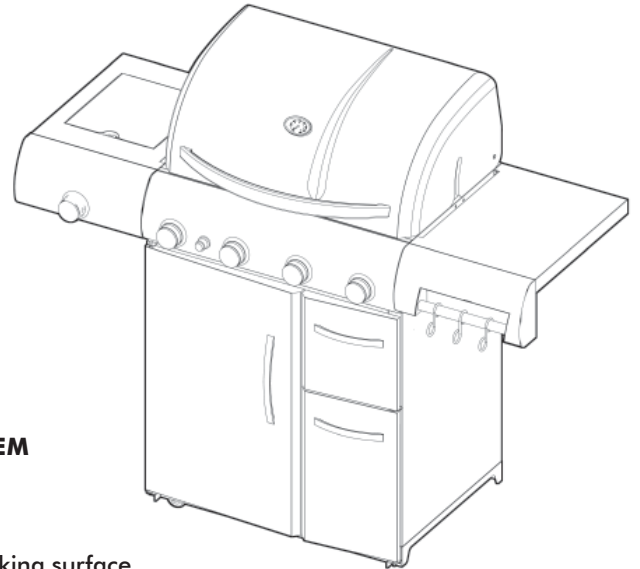

6804T8KSS1

For Outdoor Household Use Only. Not for Commercial Use.

**Need Help? Need to Register Your Grill? Looking for Aussie Parts & Accessories?
Visit us online at www.AussieGrills.com Or call Aussie Customer Service at 1-800-251-7558**

⚠ WARNING

- Failure to follow these instructions could result in fire or explosion which could cause death, serious personal injury, or property damage.
- Read and follow instructions carefully before assembly or use.
- Do not use this product for any other purpose than which it is intended.
- These instructions must be kept with the user. **SAVE THESE INSTRUCTIONS.**

⚠ WARNING

- Do not store or use gasoline or other flammable vapors and liquids in the vicinity of this or any other appliance.
- An LP cylinder not connected for use shall not be stored in the vicinity of this or any other appliance.

⚠ DANGER

If you smell gas:

1. Shut off gas to the appliance.
2. Extinguish any open flame.
3. Open lid.
4. If odor continues, keep away from the appliance and immediately call your gas supplier or your fire department.



NOTICE

Meco Corporation strives to be a quality supplier of consumer products. If we omitted any parts needed for assembly, or you need troubleshooting information, please contact us using our toll free number or visit our website.

It is important to register your grill and retain your receipt.

1-800-251-7558
8 am - 5 pm E.S.T. Monday - Friday
1-423-639-1171 (Telephone)
1-423-639-2570 (Fax)

Consumer Service Department
MECO CORPORATION
1500 Industrial Road
Greeneville, TN 37745 USA

www.aussiegrills.com

! DANGER**CARBON MONOXIDE HAZARD**

This appliance can produce carbon monoxide which has no odor. Using it in an enclosed space can kill you. Never use this appliance in an enclosed space, such as a camper, tent, car, or home.

! WARNING

To reduce the risk of serious bodily injury or death from fire or explosion:

- Never use alcohol, prescription or non-prescription drugs while assembling or safely operating this appliance.
- Do not connect LP Gas Cylinder until assembly is complete except as noted for "first time use" leak test as detailed on pages 17-18.

! CAUTION

To reduce the risk of a laceration hazard, wear protective gloves when handling parts that have sharp edges.
To reduce the risk of bodily injury from lifting, assembly will require two people.

Tools Required for Assembly (Supplied with Grill):

Phillips Screwdriver

Packing List

Description

- Warming Rack
- Cooking Grid, 3 pcs.
- Flavor Activators - 4 large, 3 small
- Grease Pan
- Foil Pan
- Left Side Shelf with Side Burner
- Side Burner Control Knob
- Hood/Body
- Right Side Shelf
- Bottom Body Panel
- Front Crossbar
- Cabinet Side Panel- Left
- Back Panel Brace wire
- Cylinder Retainer Bolt
- Cabinet Upright
- Cabinet Back Panel
- Cylinder Blocking Wire
- Cabinet Side Panel- Right
- Cabinet Bottom Panel
- Drawer Tracks, 2 pcs.
- Drawer Body
- Locking Caster, 2 pcs.
- Fixed Casters, 2 pcs.
- Cabinet Door- Left
- Drawer Front
- Cabinet Door- Right
- Door/Drawer handle, 3 pcs
- Hardware Package (not pictured)

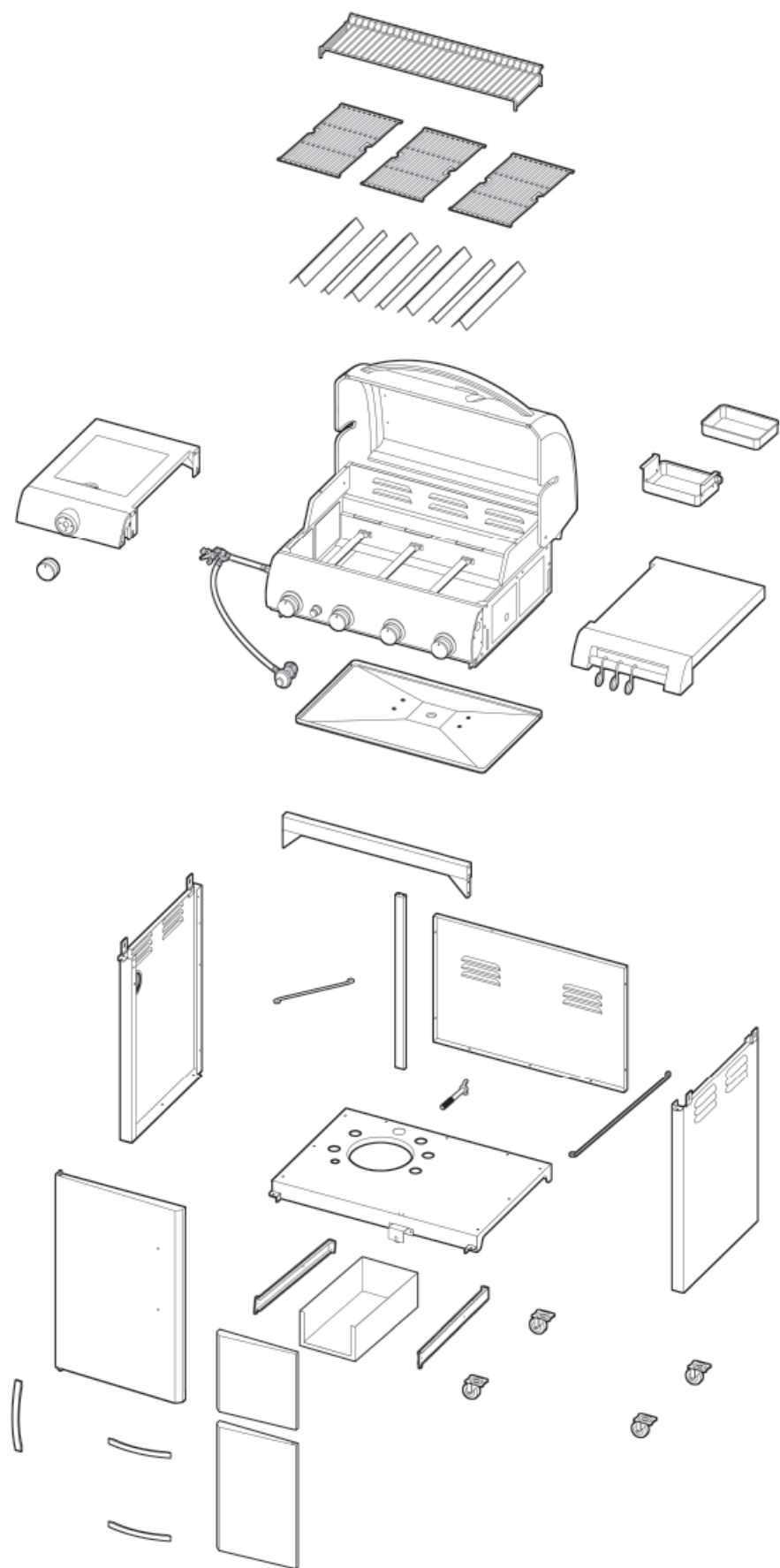

Detailed Parts List and Illustrations may be found on pages 36 & 37

Packing Lists	3	Before Using Your Grill	
Preparation for Assembly	4	Installation Codes.....	17
Assembly Instructions		Selecting a Location	17
Step 1 Caster Assembly	5	Performing a Leak Test	17
Step 2 Cabinet Bottom Assembly	5	How to Perform a Leak Test.....	18
Step 3 Side Panel Assembly	6	Lighting Grill Using the Pulse-Spark Ignitor	20
Step 4 Front Crossbar Assembly.....	7	Manually Lighting the Grill	22
Step 5 Cabinet Upright Assembly.....	7	Lighting the Side Burner	23
Step 6A Cylinder Guard Assembly.....	8	Check the Flame	23
Step 6B Cylinder Blocking Wire Assembly	8	Manually Lighting the Side Burner	24
Step 7 Door Handle Assembly	8	Cooking on the Gas Grill	
Step 8 Door Assembly.....	9	Grill Cooking (Direct Method).....	25
SStep 8 Drawer Track Assembly.....	9	Roasting (Indirect Method).....	26
Step 9A Drawer Assembly	9	Rotisserie Cooking.....	27
Step 9B Drawer Positioning	9	Warming Rack	28
Step 10 Door Assembly.....	10	End of Cooking Session	28
Step 11 Hood/Body To Cart Assembly	10	Care and Maintenance	
Step 12 Side Table Assembly	11	Cleaning the Grill	29
Step 13 Side Burner Valve Assembly	12	How to Clean the Burners	30
Step 14 Side Burner Igniter Wire Connection	12	Storage	32
Step 15A Side Burner Control Knob Assembly.....	13	Emergencies	33
Step 15B Side Burner Grid Assembly	13	Troubleshooting	33
Step 16A Bottom Body Panel Assembly	13	Important Notice- LP Cylinder with OPD	35
Step 16B Foil Pan/Grease Pan Assembly.....	13	Replacement Parts	
Step 17A Warming Rack Assembly	14	Parts Illustrations	36
Step 17B Flavor Activator Assembly	14	Parts List	37
Step 17C Cooking Grid Assembly	14	Limited Warranty	38
Step 18 Battery in Igniter Installation	14		
Connecting/Disconnecting the Gas		Register your grill and retain your receipt.	
Using Gas	15		
LP Gas Cylinder.....	15		
LP Hose & Regulator	16		
Connecting LP Gas Cylinder	16		
Disconnecting LP Gas Cylinder	16		

Preparation for Assembly

Remove grill and all the packaging from carton and place on floor. Make sure there are no loose parts.

NOTE: Before using your grill, read the instructions and your manual.

For easier set-up and assembly, follow instructions of each step in the order they are written as you look at the diagrams. If accessories mentioned in certain assembly steps do not come with your model, skip that step and proceed to the next step that applies to your model.

If you have any questions or need help, contact **Customer Service at 1-800-251-7558** or go to **www.aussiegrills.com**. Be sure to have the grill model number and serial number printed on the black label located inside the left door of the cabinet. If you need replacement parts, look in the Parts List Section to find the exact parts you need. **If you need a replacement part under warranty, a proof of purchase will be necessary.** You will be asked to forward your proof of purchase via e-mail or to fax your proof of purchase to 423-639-1055 and reference your model and serial number. **It is important to register your grill and retain your receipt.**

Assembly Instructions

Step 1 Caster Assembly

Lay Cabinet Bottom Panel upside down, so that the flat surface is on the floor. Assemble Fixed Casters to the LEFT Side (the side closest to the cutouts) of Cabinet Bottom Panel and Swivel Lock Casters to the RIGHT Side of Cabinet Bottom Panel. Insert 1/4-20 x .60" Bolts through the caster bracket holes into the threaded holes in the Cabinet Bottom Panel. Tighten the bolts. Push the lever on the two Locking Casters to lock so the caster wheels do not roll.

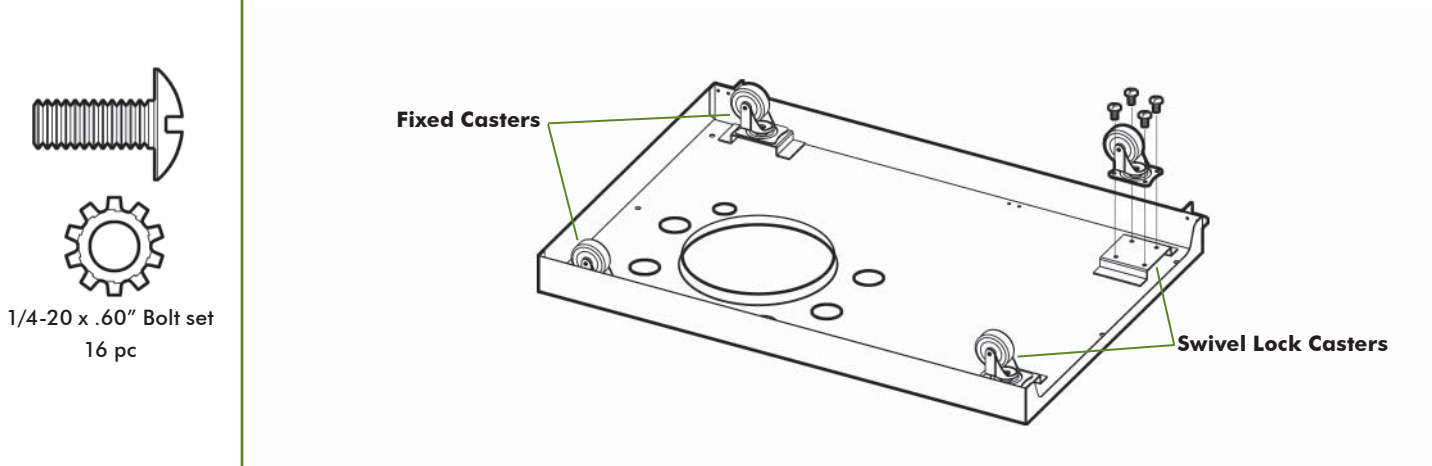

Step 2 A. Cabinet Bottom Assembly

With Back Panel on floor, place Cabinet Bottom Panel against Back Panel edge and align the holes. Install three 1/4-20 x .50 Bolts through the holes and secure with three 1/4-20 Nuts.

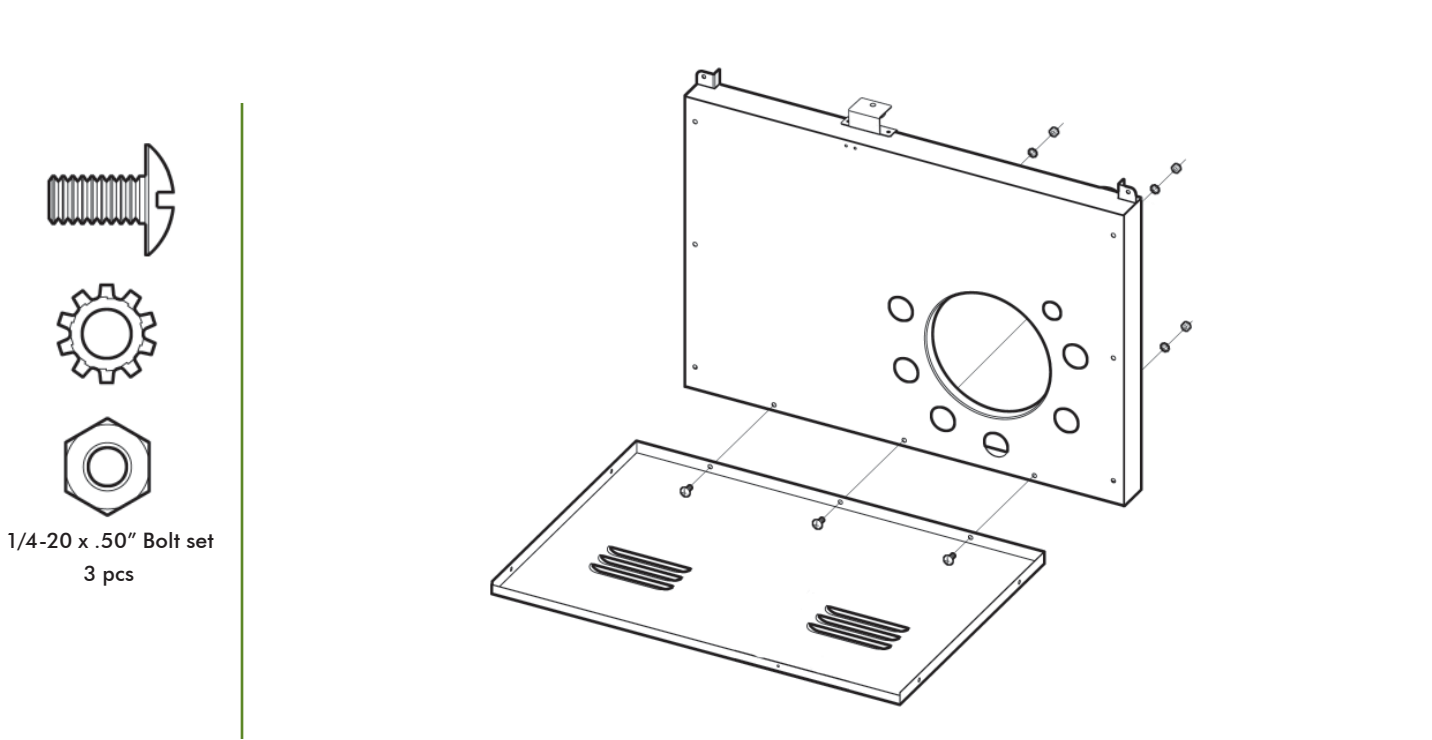

Step 3 Side Panel Assembly

Attach Left Side Panel and Right Side Panel to Cabinet Bottom Panel with six 1/4-20 x .50" Bolts and 1/4-20 Nuts.

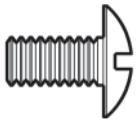

1/4-20 x .50" Bolt set
6 pc

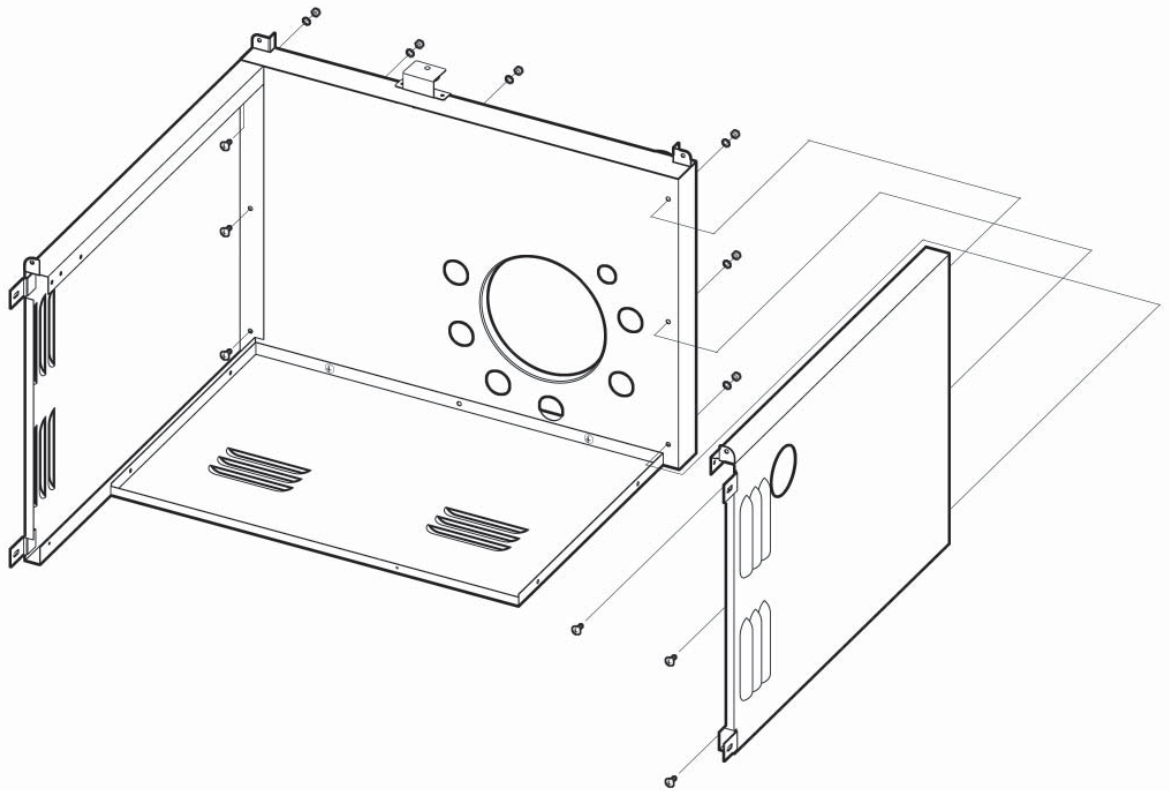

Secure Left and Right Side Panels to Back Panel with four 5/32 x .31" Bolts through the inside of the Back Panel.



5/32 x .31" Bolt set
4 pc

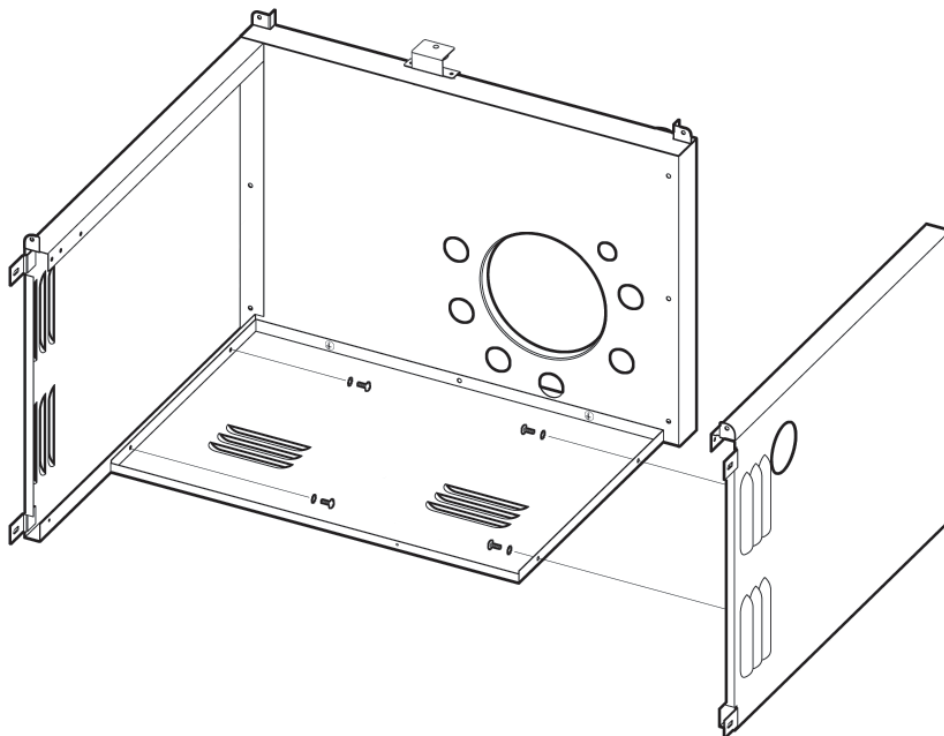

Step 4 Front Crossbar Assembly

Turn cart assembly up on casters. Attach Front Crossbar, with the triangle braces facing down and the flat surface to the front, to Side Panels with six 1/4-20 x .50" Bolts into the threaded holes in the top inside ends of Side Panels.

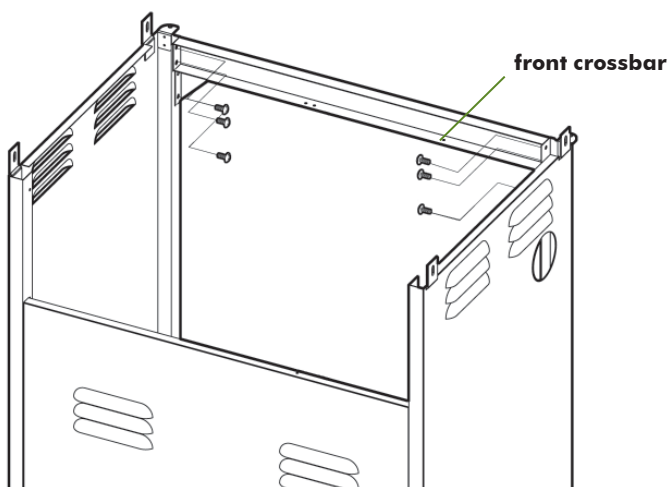
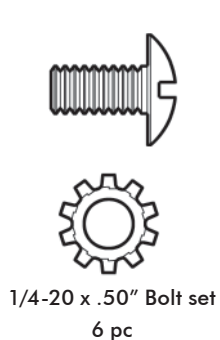

Step 5 Cabinet Upright Assembly

Attach Cabinet Upright to Cabinet Bottom and Front Crossbar with four 5/32 x .31" Bolts. Orient Upright so that Match-holder/Chain is closest to top of cabinet (Front Crossbar).

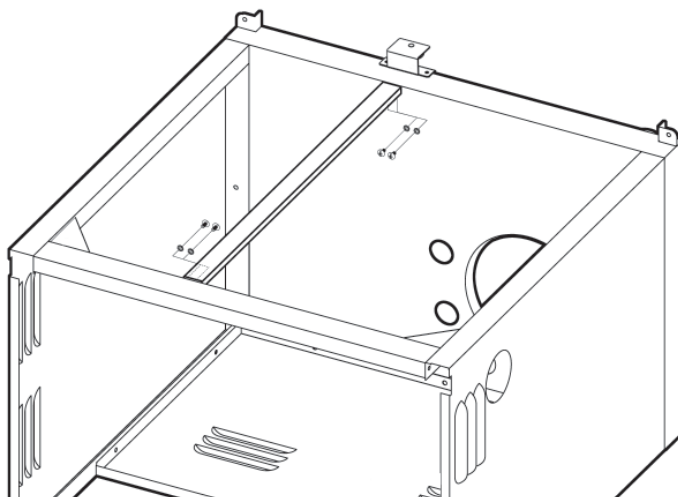
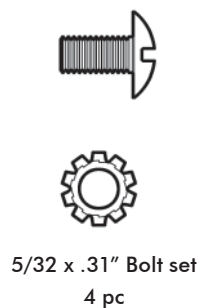

⚠ WARNING

To reduce the risk of serious bodily injury or death from fire or explosion:

- Never remove guards or devices to prevent storage of spare or oversize LP Gas Cylinders not recommended for this grill.

Step 6

A. Cylinder Guard Assembly

Attach Wire Guard to Front Crossbar and Back Panel with two 5/32 x .47" Bolts.

B. Cylinder Blocking Wire Assembly

Attach Cylinder Blocking Wire to Right Side Panel with one 5/32 x .47" Bolt and nut. Attach to Bottom Panel with one 5/32 x .47" Bolt.

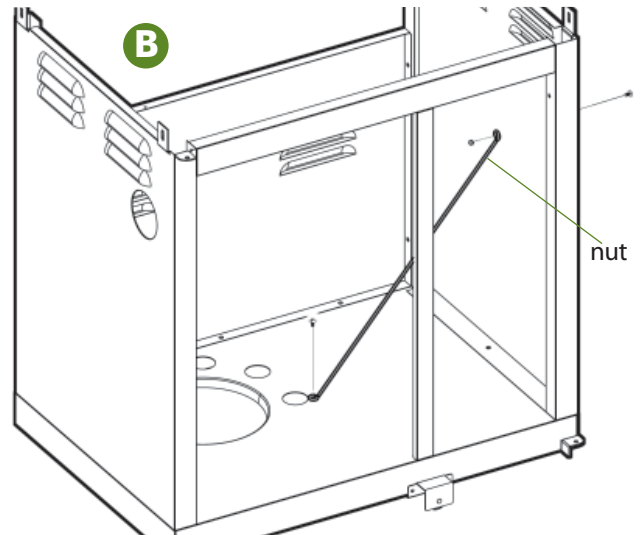
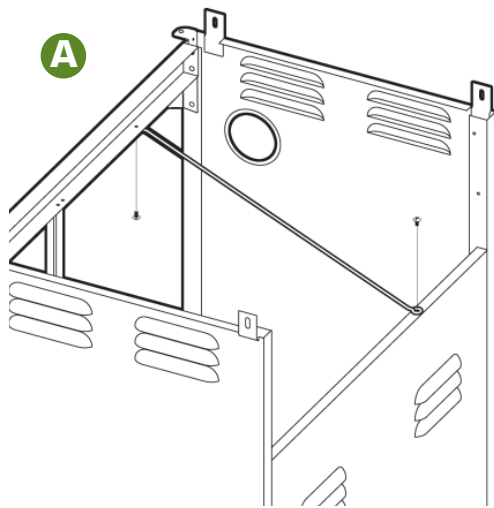
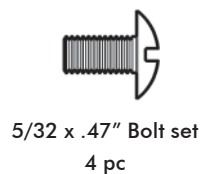

Step 7

Door Handle Assembly

Assemble Handle to Left Door using two 5/32 x .31" Bolts. Repeat with Right Door.

Note: 2 extra screws provided.

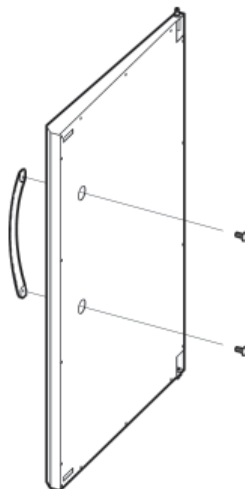
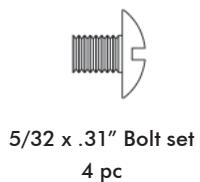

Step 8 Drawer Track Assembly and Cylinder Retaining Bolt Installation

A. Attach one Drawer Track to Back Panel and Cabinet Upright using four 5/32 x .31" Bolts. Attach other Drawer Track to Back Panel and Right Side Panel using four 5/32 x .31" Bolts.

B. Install the Cylinder Retainer Bolt through the hole in the back of the Bottom Shelf into the nut welded underneath.

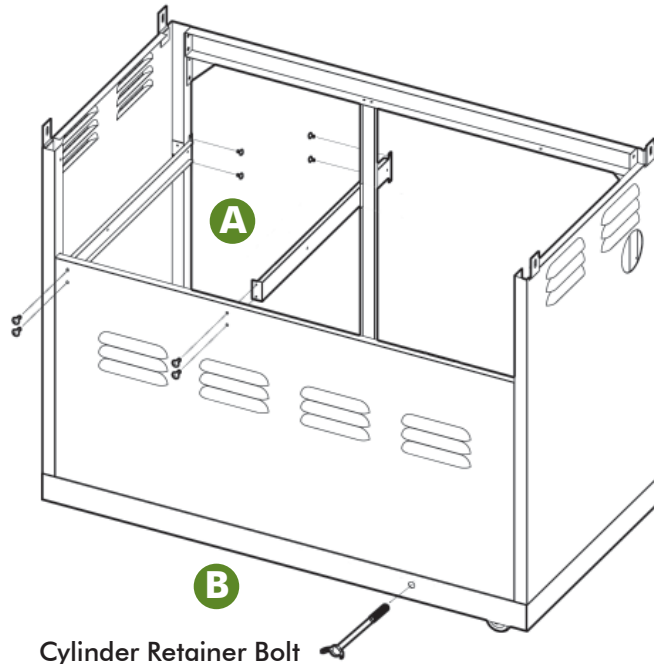
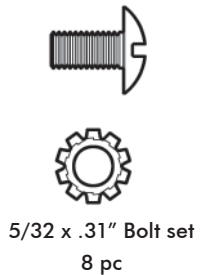

Step 9 A. Drawer Assembly

Assemble Handle to Drawer Front with two 5/32 x .31" Bolts. Note: 1 extra screw provided.

Attach Drawer Front to Drawer Body with six 5/32 x .31" Bolts into threaded holes in inside of Drawer Front.

5/32 x .31" Bolt set
8 pc

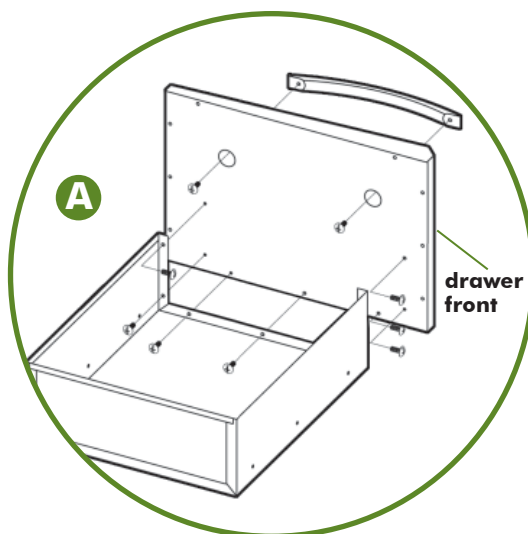

B. Drawer Positioning

Slide Drawer Assembly over the Drawer Tracks to position the Drawer.

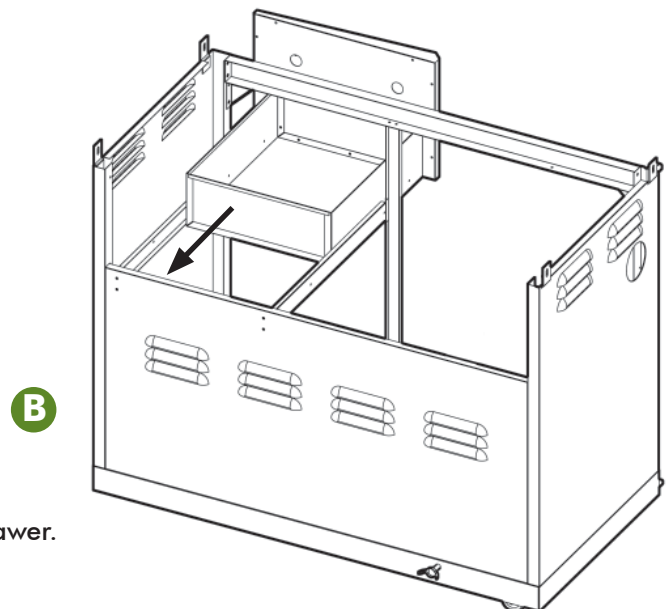

Step 10 Door Assembly

Install LEFT Door. Drop bottom door pin into Cabinet Bottom Panel hole. Swing top of door toward hole in top of Left Side Panel. Depress spring-loaded pin with thumb while sliding pin into Left Side Panel hole until it snaps into place.

Right Door assembly is similar; Fixed pin is under drawer and inserts into hole in door and spring-loaded pin is in the BOTTOM of small door and functions the same.

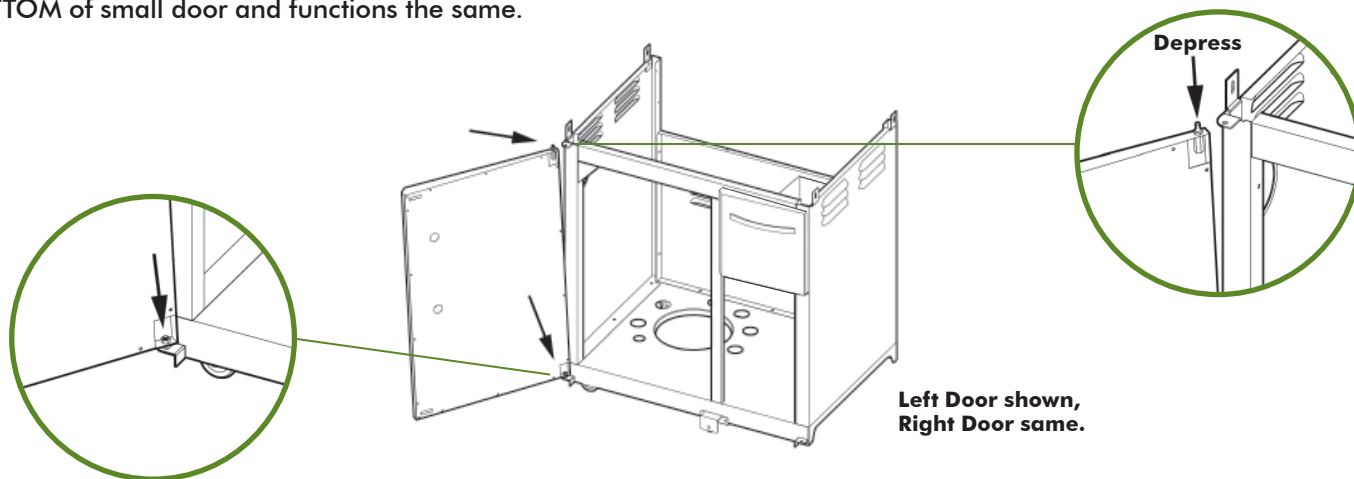

⚠ CAUTION

To reduce the risk of bodily injury from lifting, the following assembly steps #s 9 and 10 will require two people.

Step 11 Hood/Body To Cart Assembly

Lift the Hood/Body Assembly over the cart assembly and set it down until it rests on the inside top flanges of the cart.

Align the holes in the side of the Hood/Body with the holes in the Side Panel brackets. Insert four 1/4-20 x .50 Bolts through the holes in cabinet flanges and into threaded inserts in firebox and tighten after all are installed.

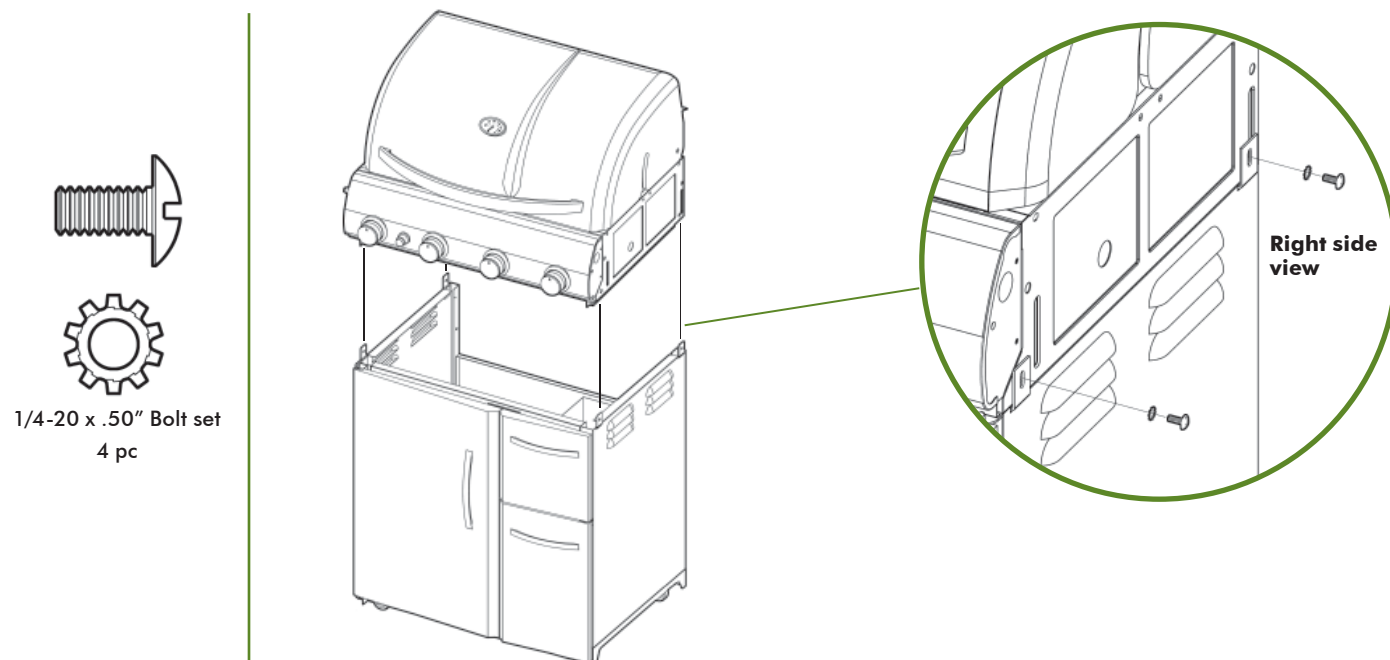

⚠ CAUTION

Prior to performing any further assembly, **PERFORM "FIRST TIME USE" LEAK TEST** as detailed on pages 17-18.

If the grill is fully assembled before performing the First Time Use leak test, the side tables will need to be removed in order to perform the leak test on the main burner valves inside the control panel, behind the knobs, .

Step 12 Side Table Assembly

A. Screw two 1/4-20 x .50" Bolts into the two bottom threaded inserts on the outside of the Bowl. Do not screw Bolts all the way. Leave 1/8" of each Bolt exposed.

Align the bottom two holes ("keyhole slots" in detail) on the inner side of the LEFT Side Table with the two bolts threaded partly into the inserts in the Side of the Bowl then slide the Side Burner Table over the Bolts.

B. Holding the Side Burner Table in place, install two 1/4-20 x .50" Bolts from the **inside** of the Bowl into the two top threaded holes in the Side Table.

C. From under the Side Table, install one 5/32 x .31" bolt through the Side Table end into the side of the Bowl.

Repeat this assembly for the RIGHT Side Table. Tighten all bolts.

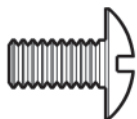

1/4-20 x .50" Bolt set
8 pc



5/32 x .31" Bolt set
2 pc

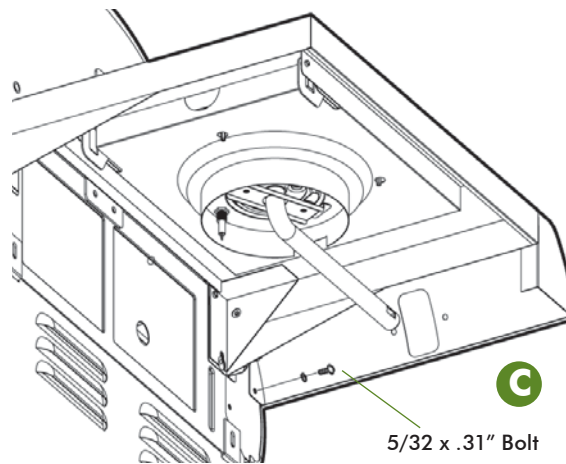
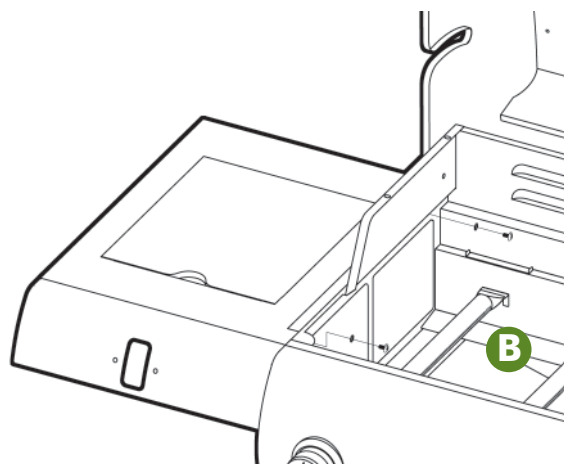
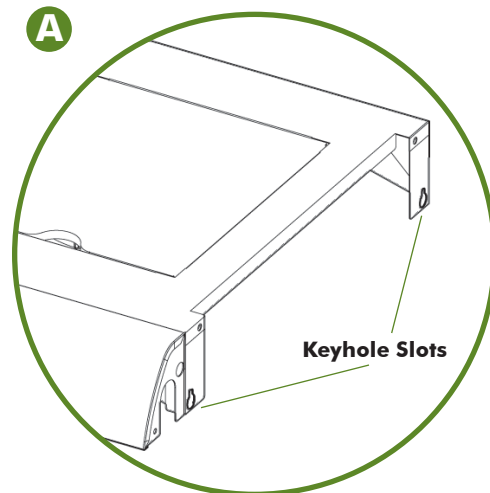
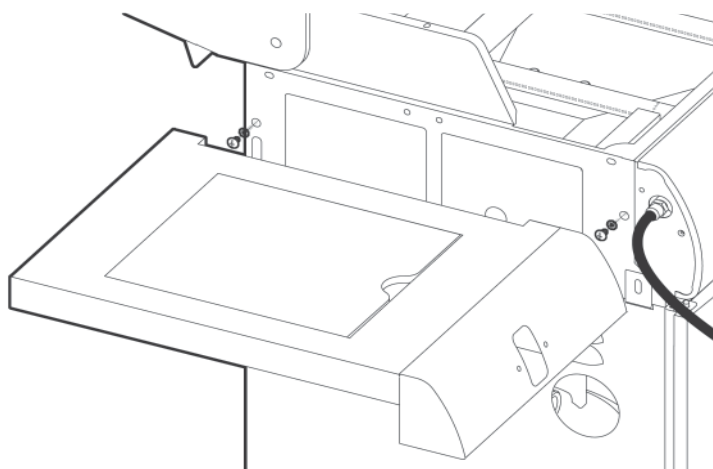

5/32 x .31" Bolt

▲ CAUTION

To avoid possible damage to grill, DO NOT ATTEMPT TO LIFT GRILL BY THE SIDE TABLES

Step 13 Side Burner Valve Assembly

NOTE: Side Burner Valve is already attached to the regulator hose.

A. Install the Side Burner Valve from underneath the LEFT Side Table. First insert the valve stem out through the hole in the bezel and fascia on the front of the side table. Next, flex the tube of the burner down and insert the nozzle into the opening in the burner tube.

B. Install two 5/32" x .31" Bolts through the Control Knob Bezel and front of Side Table and into the threaded Valve bracket holes. Install the top bolt first by twisting the valve/bracket to align only the top holes. Do not tighten completely. Next, twist the valve/bracket to align the bottom holes and install the second bolt. Tighten both.



5/32 x .31" Bolt
2 pc

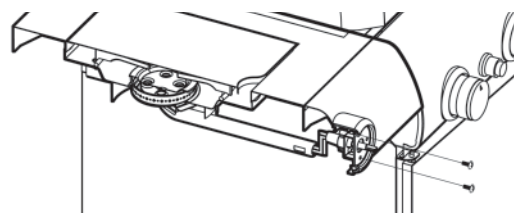
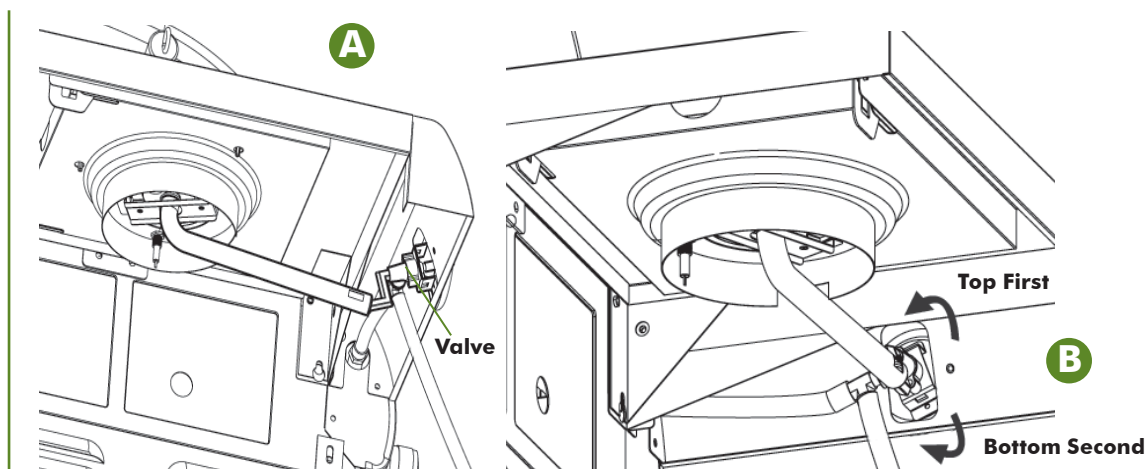

Step 14 Side Burner Igniter Wire Connection

The Side Burner Igniter Wire is pre-installed and connected to the Ignition Box. Attach the wire to the Side Burner electrode by sliding the wire connector onto the electrode terminal.

Underside view of
Side Table/Side Burner

Note:
Shown without Regulator
Hose for clarity.

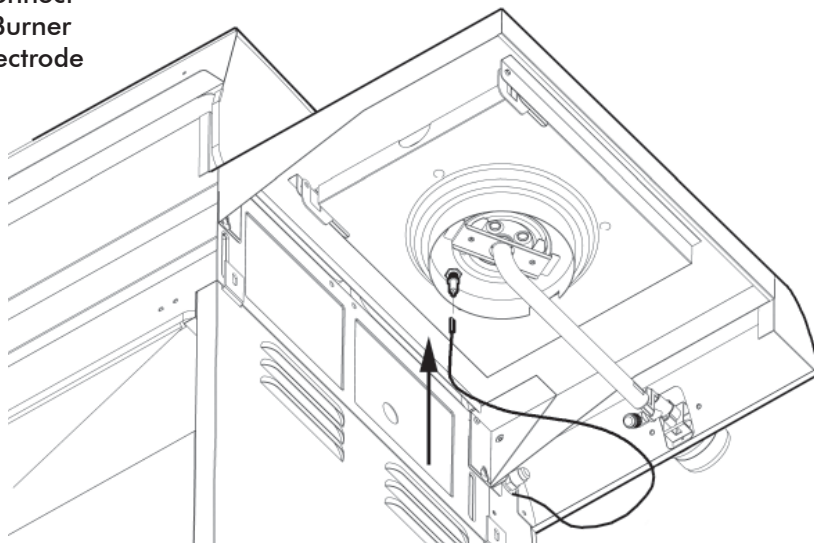

⚠ CAUTION

To avoid possible damage to grill, DO NOT ATTEMPT TO LIFT GRILL BY THE SIDE TABLES

Step 15

A. Side Burner Control Knob Assembly

Align the flat keyed hole in the Control Knob with the keyed stem of the Side Burner Valve. Push the Control Knob onto the Side Burner Valve stem.

B. Side Burner Grid Assembly

Place the Side Burner Grid onto Side Burner Table, allowing the three protruded ends to fall into the three holes around the Side Burner.

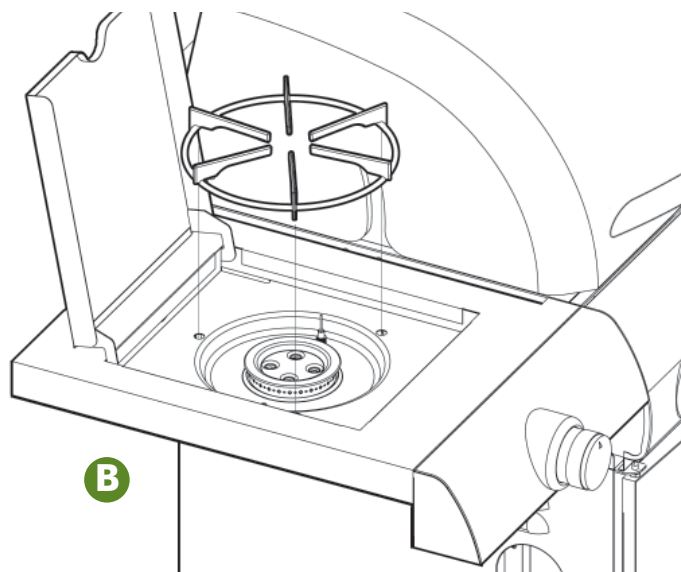
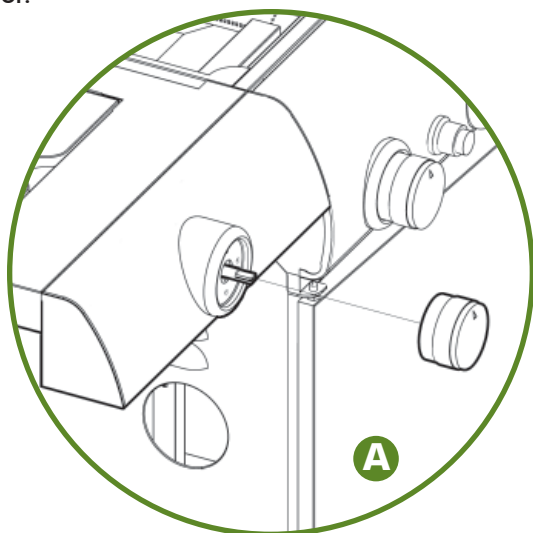

Step 16

A. Bottom Body Panel Assembly

Slide the Bottom Body Panel into the guides of the Body assembly. Secure Bottom Body Panel to Body assembly with one 5/32 x .31" Bolt on each side.

B. Foil Pan/Grease Pan Assembly

Insert the Foil Pan into the Grease Pan. Slide the Grease Pan into the guides under the Bottom Body Panel

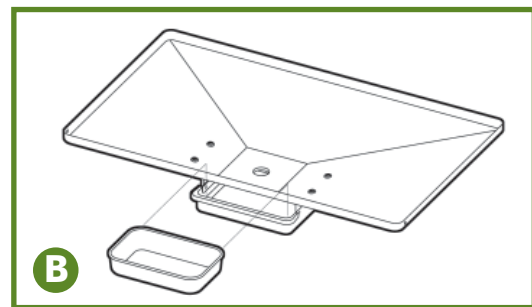
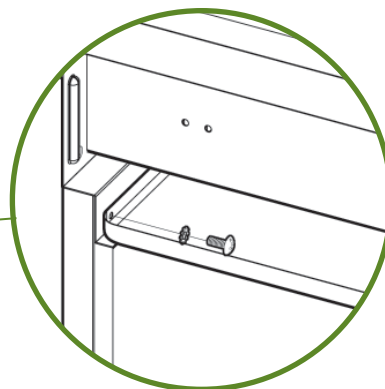
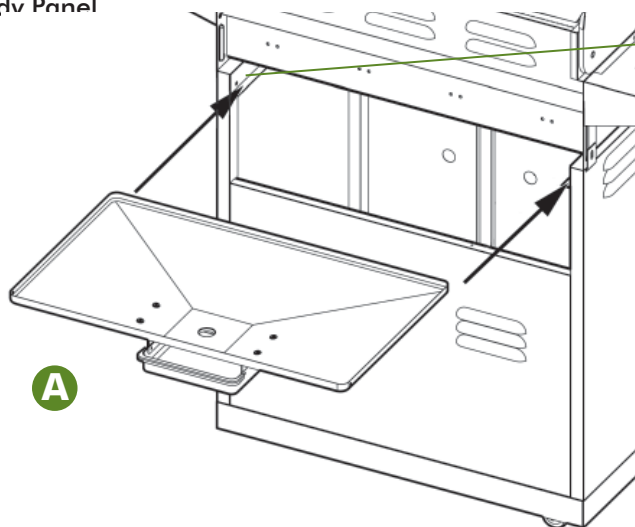
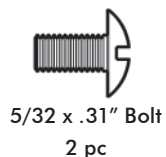

⚠ CAUTION

To reduce the risk of a laceration hazard:

- Wear protective gloves when installing warming rack. Hood and Bowl edges could be sharp.

Step 17 Warming Rack / Flavor Activator / Cooking Grid Assembly

A. Insert Warming Rack leg ends into holes on top edge of firebox. Seat securely.

B. Lay a large Flavor Activator over each Burner on the lower body ridges. Lay a small Flavor Activator between each large Flavor Activator. Each Flavor Activator has individual guides on the body ridges to keep in place.

C. Place the Cooking Grids over the Flavor Activators on the upper Body ridges.

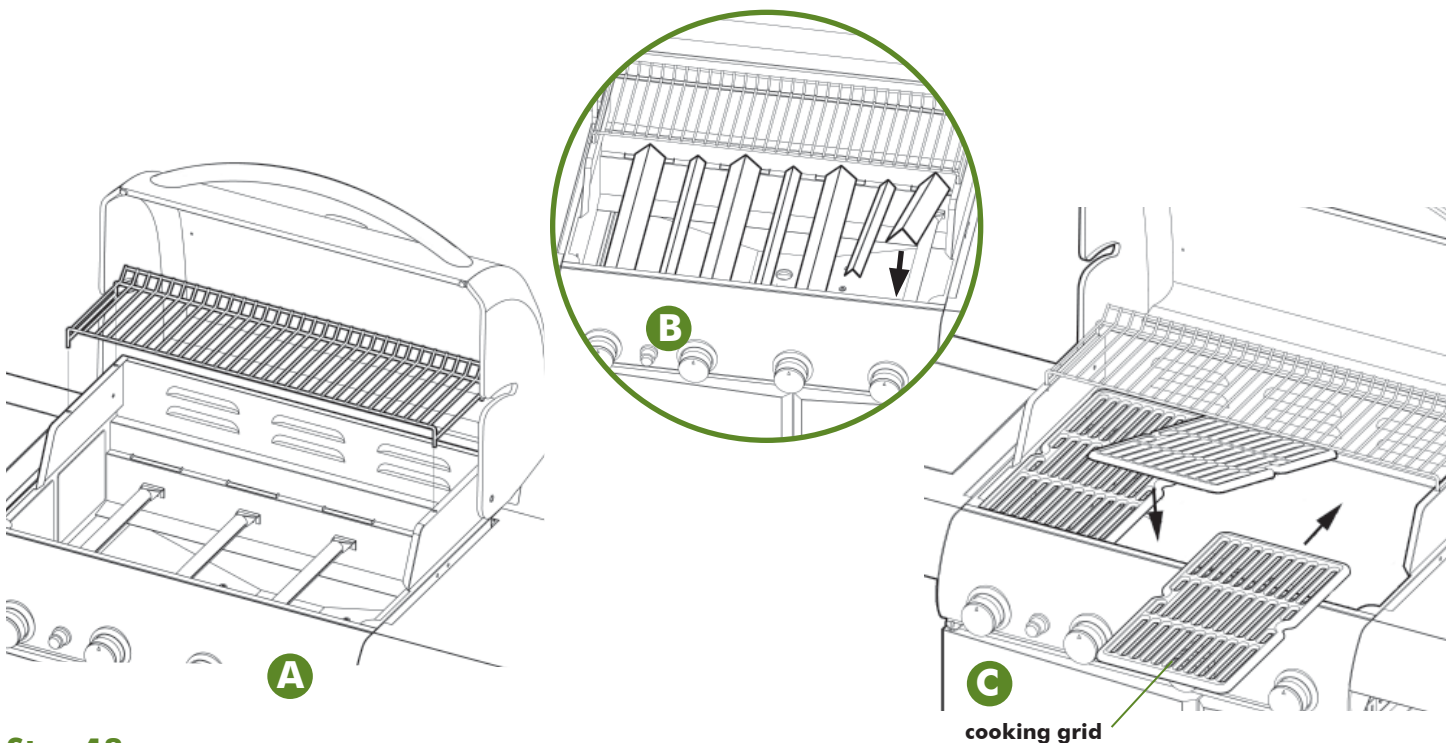

Step 18 Battery in Igniter Installation

Unscrew Igniter Cover and insert AA Battery with the negative "-" end going in first. Replace the cover and tighten securely.

Battery
AA 1.5v Alkaline
1 pc

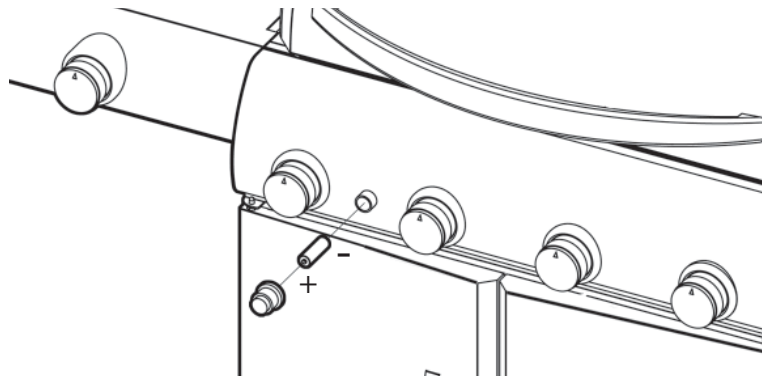

This Completes the Grill Assembly.

Connecting/Disconnecting the Gas

Using Gas

DANGER

Carbon Monoxide Hazard

- This appliance can produce carbon monoxide which has no odor. Using it in an enclosed space can kill you.
- Never use this appliance indoors, on recreational vehicles, or boats.

WARNING

To reduce the risk of serious bodily injury or death from fire or explosion:

- Use only propane gas with this LP gas grill.
- Do not attempt to convert an LP unit to natural gas.
- Always use a gas appliance outdoors in an open area with good ventilation to avoid breathing toxic fumes from leaking gas, explosion, or fire. As with all conventional fuels, the burning process consumes oxygen and produces toxic gases, including carbon monoxide. In addition, the combustion products of such fuels, including liquefied petroleum (LP), contain chemicals known to the state of California and other authorities to cause cancer, birth defects, and other reproductive harm.

Any use or alteration of this unit not intended could be unsafe and will void your warranty.

LP Gas Cylinder

DANGER

- If you see, smell, or hear the hiss of LP gas escaping from the cylinder:
 1. Do not attempt to light appliance.
 2. Extinguish any open flame.
 3. Disconnect from fuel supply.

The LP Gas Cylinder, for use with this LP gas grill, must meet the following requirements:

1. 12" diameter x 18" tall, 20 lb. maximum capacity
2. Overfill Prevention Device (OPD) safety feature (should be noted on cylinder)
3. Must be constructed and marked in accordance with Specifications for LP Gas Cylinders of the U.S. Department of Transportation (DOT) or the National Standard of Canada, CAN\CSA-B339, Cylinders, Spheres and Tubes for Transportation of Dangerous Goods; and Commission, as applicable (See collar for marking)
4. Must have collar to protect LP Gas Cylinder valve.
5. Must be marked "PROPANE."
6. Must be provided with a cylinder connection device that is compatible with the grill's connection.

WARNING

To reduce the risk of serious bodily injury from fire or explosion:

- Read and follow all warnings on LP Gas Cylinder.
- Do not operate the LP gas grill without the LP Gas Cylinder secured to the cart and oriented as shown in Assembly Instructions for Connecting the LP Gas Cylinder.
- Never connect or disconnect LP Gas Cylinder or fittings while grill is in use or is hot.
- When the LP Gas Cylinder is connected, keep the grill outside in a well-ventilated space.
- Do not use an LP Gas Cylinder if it shows signs of dents, gouges, bulges, fire damage, corrosion, leakage, excessive rust, or other forms of visual external damage; it may be hazardous and should be checked by a liquid propane supplier. Do not use an LP Gas Cylinder with a damaged valve.
- Do not store a spare LP Gas Cylinder under or near the LP gas grill.
- When grill is not in use, turn off all grill Control Knobs, LP Gas Cylinder valve and disconnect LP Gas Cylinder.
- Never fill the LP Gas Cylinder more than 80% of cylinder volume. (20 lb. maximum) Do not ask the propane supplier to over-fill the Cylinder.
- If you obtain LP gas through a cylinder exchange dealer, make sure you get a safe and adequate cylinder. Use only a licensed LP Gas Cylinder dealer.

LP Hose and Regulator

! WARNING

To reduce the risk of serious bodily injury or death from fire or explosion:

- Clean and inspect the gas hose/regulator before each use of the outdoor cooking gas appliance. The gas hose/regulator must be replaced prior to being used, if there is evidence of excessive abrasion or wear, or if the hose is cut or leaks.
- Use only the gas hose/regulator assembly that has been supplied with this gas grill. Do not use hose/regulator from another manufacturer. Replacement gas hose/regulator assembly must be specified by this grill's manufacturer before using.
- Always check for gas leaks when you connect and disconnect the hose/regulator to the LP Gas Cylinder, especially after a period of storage (for example, over winter).
- Make sure there are no sharp bends in the hose.
- Make sure the hose/regulator does not contact any heated surfaces.

NOTE:

If the hose/regulator assembly is not working properly and you need a replacement, contact **Customer Service at 1-800-251-7558** or go to www.aussiegrills.com.

Be sure to **have the grill model number and serial number** printed on the black label, located inside the left door of the cabinet. **If you need a replacement part under warranty, a proof of purchase will be necessary.** You will be asked to forward your proof of purchase via e-mail or to fax your proof of purchase to 423-639-1055 and reference your model and serial number. **It is important to register your grill and retain your receipt.**

Connecting LP Gas Cylinder

1. Fill empty OPD LP Gas Cylinder at your local gas supplier.
2. Place the LP Gas Cylinder in the large hole in the Bottom Panel inside the cabinet. Rotate the LP Gas Cylinder so the Cylinder nozzle is toward the door opening for proper vapor withdrawal. Lock the LP Cylinder in place by tightening wing bolt on the outside rear of the cabinet base so that it seats against the ring base of the LP Cylinder.
3. Remove the protective cap from the LP Gas Cylinder valve. (Save cap for re-capping.) Hold Regulator in a straight line with LP Gas Cylinder valve so the connection does not cross thread. Insert Regulator Nipple into the LP Gas Cylinder valve. Hand tighten coupling nut in clockwise direction. **DO NOT USE TOOLS.**

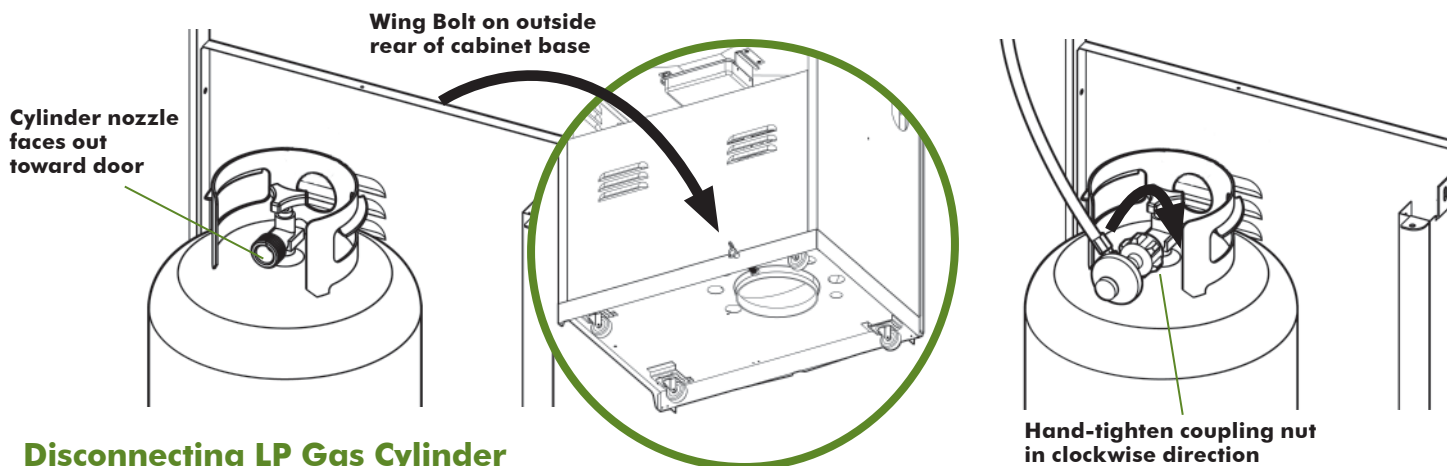

Disconnecting LP Gas Cylinder

1. Turn all Control Knobs to the "Off" position and turn the handle on the LP Gas Cylinder clockwise until it stops.
2. Turn coupling nut on regulator counterclockwise until regulator is released from the threaded LP Gas Cylinder nozzle.
3. Place the protective cap over LP Gas Cylinder nozzle.

Before Using Your LP Gas Grill

Installation Codes

WARNING

To reduce the risk of serious bodily injury or death from fire or explosion:

- This installation must conform with local codes or, in the absence of local codes, with either the National Fuel Gas Code, ANSI Z223.1/NFPA 54 Natural Gas and Propane Installation Code, CSA B149.1, or Propane Storage and Handling Code, B149.2 or the Standard for Recreational Vehicles, ANSI A 119.2/NFPA 1192 and CSA Z240 RV Series, recreational Vehicle Code, as applicable.
- If an external electrical source is utilized, the outdoor cooking appliance, when installed, must be electrically grounded in accordance with local codes or, in the absence of local codes, with the National Electrical Codes, ANSI/NFPA 70, or the Canadian Electrical Code CSA C22.1.
- Keep any electrical supply cord and the fuel supply hose away from any heated surfaces.

Selecting a Location

WARNING

To reduce the risk of serious bodily injury or death from fire or explosion:

- This outdoor cooking appliance must be used only outdoors and shall not be used in a building, garage, breezeway, carport, porch or in any enclosed area. Locate outdoor cooking appliance in an area with good ventilation on a level stable surface clear of combustible and flammable material.
- Locate your LP gas grill at least 10 feet away from your house or any building.
- Maintain minimum clearances of 36" from back and sides of grill to any combustible construction.
- Do not locate this appliance under overhead, unprotected combustible construction.
- This outdoor cooking appliance is not intended to be used in or on boats or installed in or on recreational vehicles.
- Never use gas grill as a space heater.

Performing A Leak Test

WARNING

To reduce the risk of serious bodily injury or death from fire or explosion:

- Perform a leak test before lighting your grill for the first time.
- Perform a leak test if any gas component is changed.
- Perform a leak test a minimum of once a season.
- Perform a leak test after a prolonged period of storage or non-use.
- Perform a leak test if the regulator flow-limiting device has been activated.
- Perform a leak test on the propane cylinder and exposed connections every time the propane cylinder is refilled or exchanged.
- Perform leak tests in a well ventilated area.
- Never use an open flame to test for gas leaks.
- Never smoke near the grill during a leak test.
- Do not perform a leak test on a grill while it is hot or in use.
- Do not use the gas grill if you detect a gas leak that cannot be corrected by using the leak test procedures.

Before using your gas grill, perform a leak test on the Control Valves, Hose/Regulator Connections, Fittings and LP Gas Cylinder.

How to Perform A Leak Test “FIRST TIME USE” and as required

Supplies Needed for a Leak Test:

- Clean paint brush
- Water
- Dish washing liquid

1. Use an LP Gas Cylinder equipped with an OPD (Overfill Prevention Device) and have it filled at an authorized LP gas dealer by a qualified attendant.
2. Make sure all grill Control Panel Knobs are turned to the “Off” position and verify that the LP Gas Cylinder valve is closed by turning the knob on the LP Gas Cylinder clockwise until it stops.
3. Mix one part of water with one part of dish washing liquid.
4. Figures 1, 2, 4 and 4a show the grill at assembly step 9, prior to attaching the Side Tables, and illustrate the initial steps in the “FIRST TIME USE LEAK TEST”.

Detach the Control Panel from the Grill Body/Firebox by removing the two 5/32” Bolts from each end. (Fig. 1) Gently pull the Control Panel away from the Body until Valves disengage from the Tubular burner ends. (Fig. 2) Support the Control Panel to keep tension off of the igniter wire leads or detach the wire leads from the Starter Button module.

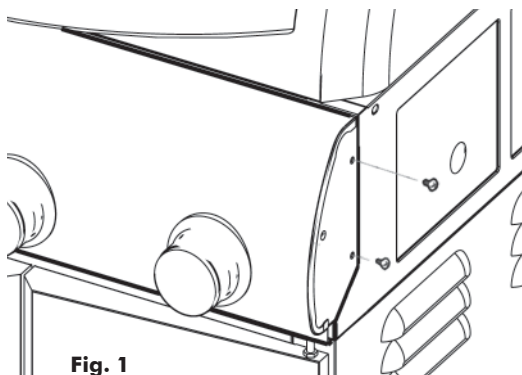

Fig. 1

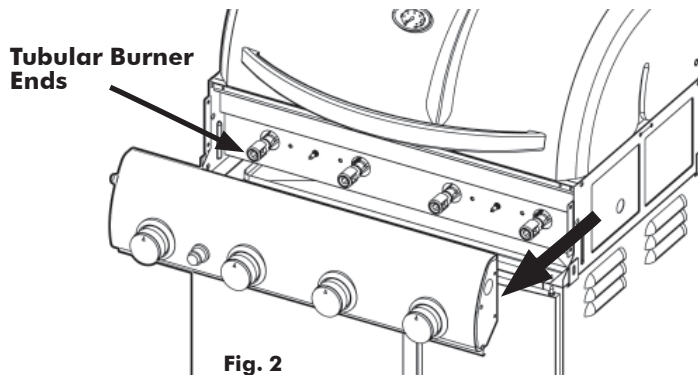

Fig. 2

5. With the regulator hose connected to the LP Gas Cylinder, turn the knob on the Cylinder counterclockwise. (Fig. 3)

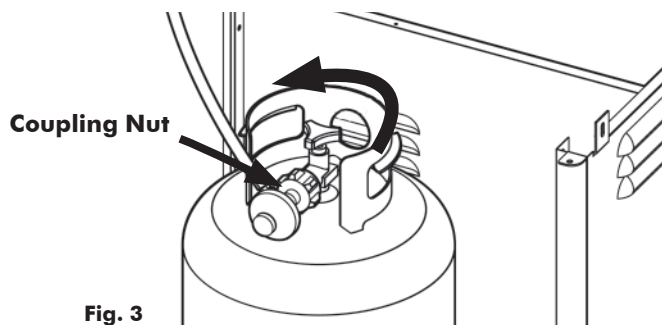
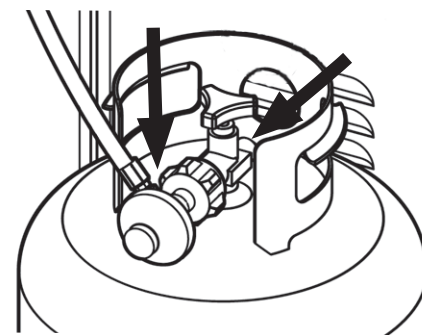

Fig. 3

Check for leaks at
Cylinder Valve and
Regulator Connection
and Fittings

Fig. 3a



CAUTION

To reduce the risk of a laceration hazard:

- Wear protective gloves when removing or replacing Control panel, which could have sharp edges.

6. Check for leaks by brushing the soap solution on all gas valves, hose connections and fittings. (Shown by the heavy arrows in Fig. 3a, 4 and 5) Make sure you generously brush the locations with the soap solution, completely surrounding the connections and fittings.

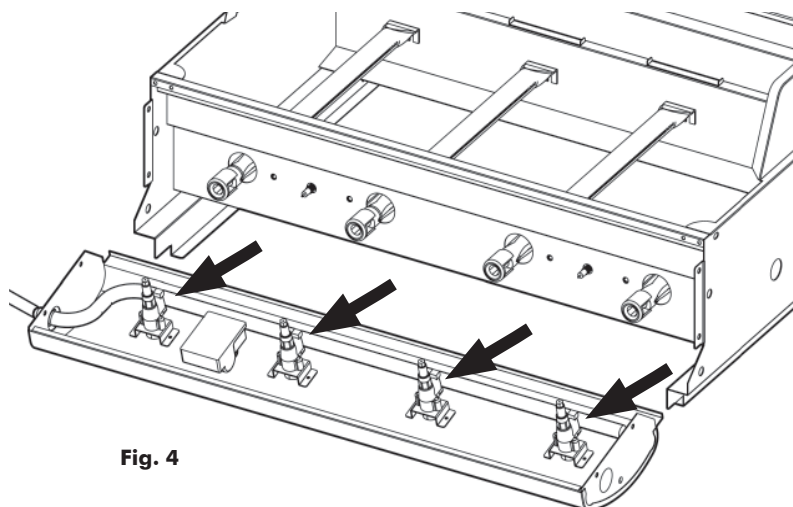

Fig. 4

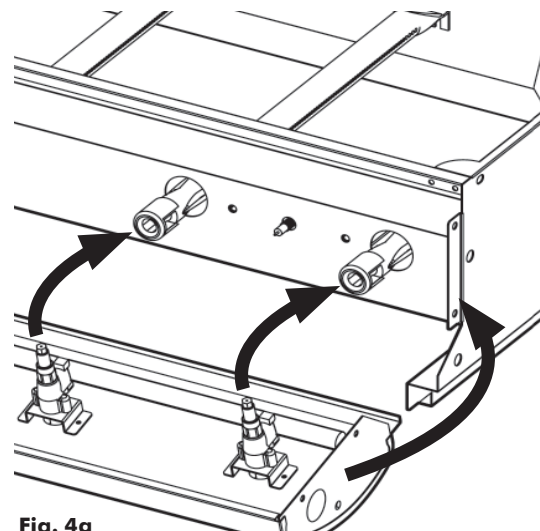

Fig. 4a

NOTE: After checking the connections and fittings in Figure 4, replace the control panel in the same manner as it was removed. Take special care to be sure the valve ends are inserted into the openings in the burner ends as shown in Figure 4a. If all valve ends do not immediately align with the burner end openings, starting at one end, grasp the tube burner inside the firebox and gently move it until the valve seats in the open end. Also note that the end caps of the control panel skin fit to the outside of the flanges on the firebox as shown in Figure 4a.

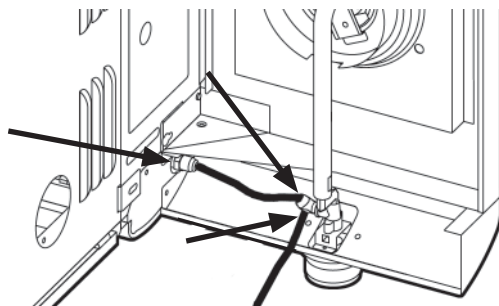

Fig. 5

7. If “growing” bubbles appear on any of the connection points, you have detected a gas leak. Immediately close the LP Gas Cylinder valve by turning handle clockwise
- If leak appears at either end of hose and regulator assembly, retighten the connection at the leak, but do not over-tighten. (NOTE: Only hand tighten at coupling nut in Fig. 3 shown on previous page) Repeat Leak Test.
 - If the leak is coming from the Gas Cylinder, from the valves at the Control Knobs, or if the leak cannot be stopped, do not use the grill. Call Customer Service at 1-800-251-7558. Be sure to **have the grill model number and serial number** printed on the black label, located inside the left door of the cabinet. **If you need a replacement part under warranty, a proof of purchase will be necessary.**
8. Upon completion of leak test, turn all Control Knobs to the “Off” position. Turn the handle on the LP Gas Cylinder clockwise until it stops. Disconnect LP Gas Cylinder by turning coupling nut on regulator in a counterclockwise direction until regulator is released from threaded LP Gas Cylinder nozzle.
9. Place the protective cap over LP Gas Cylinder nozzle.
10. Re-attach the wire leads to the Igniter Button. Replace Control Panel around flanges at Bowl ends and align bolt holes on each side. Replace and retighten all bolts. (Fig. 1)

Lighting the Grill Using the Pulse-Spark Ignitor

! WARNING

To reduce the risk of death or serious injury from an explosion or a fire beneath the grill:

- Inspect and clean Burner/Venturi Tubes for insects or insect nests. Spiders or small insects can build nests, webs, and lay eggs in the grill's Venturi Tubes, (Fig 15, page 28) obstructing the flow of gas to the Burner. The backed-up gas can ignite behind the Control Panel and cause a fire beneath the grill, posing the risk of death or serious bodily injury. This is known as a "flashback."
- Be sure Burners are re-installed properly before using grill.

Should you notice that your Burner(s) are getting hard to light or the flame is not as hot as it once was, refer to the "How to Clean your Burners" section on page 28, to remove any possible obstructions.

! WARNING

To reduce the risk of serious bodily injury or death from fire or explosion:

- Open Hood before lighting the grill to prevent an explosion from gas build-up.
- During failed lighting attempts, or if the Burners go out during operation, turn Control Knobs "Off" to dissipate any accumulation of gas. Wait five minutes before repeating lighting procedure.
- Light each burner from the left before lighting the next burning to prevent gas from accumulating.

1. Open the Hood.
2. **IMPORTANT:** Make sure Control Knobs are turned "Off." (Fig. 7)
3. Turn the LP Gas Cylinder valve open counterclockwise until it stops. (Fig. 8)

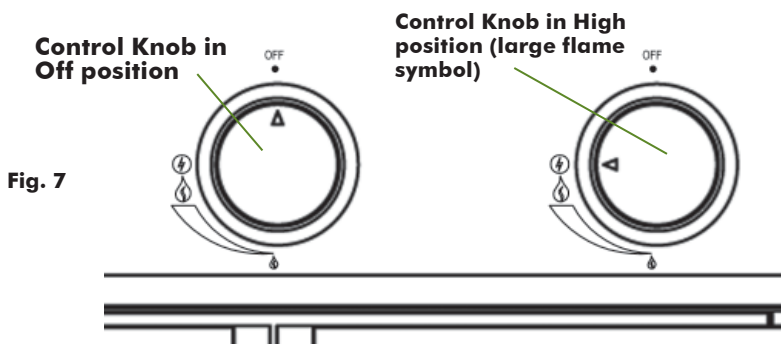

Fig. 7

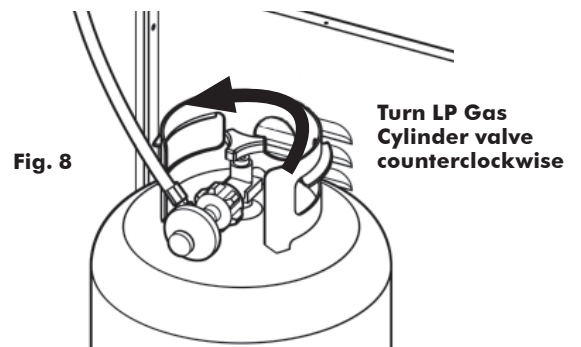

Fig. 8

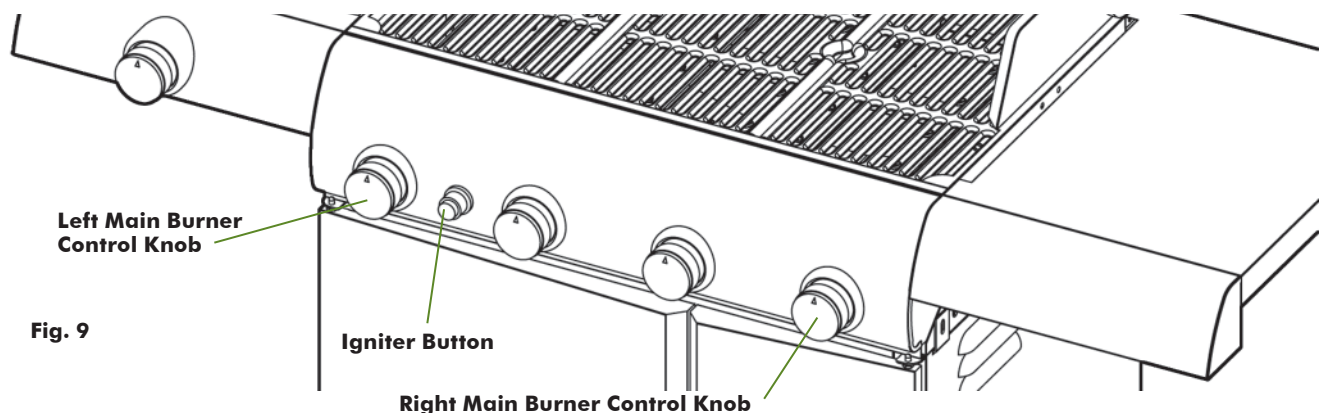

Fig. 9

4. Push far left Main Burner Control Knob in on Control Panel and turn counterclockwise to the High position. (Figs. 7 and 9)

5. Push the Igniter Button in until the Burner is lit. Listen for the spark ignition, and look to make sure the Burner is lit. If no spark, see **Troubleshooting Section on page 31**.

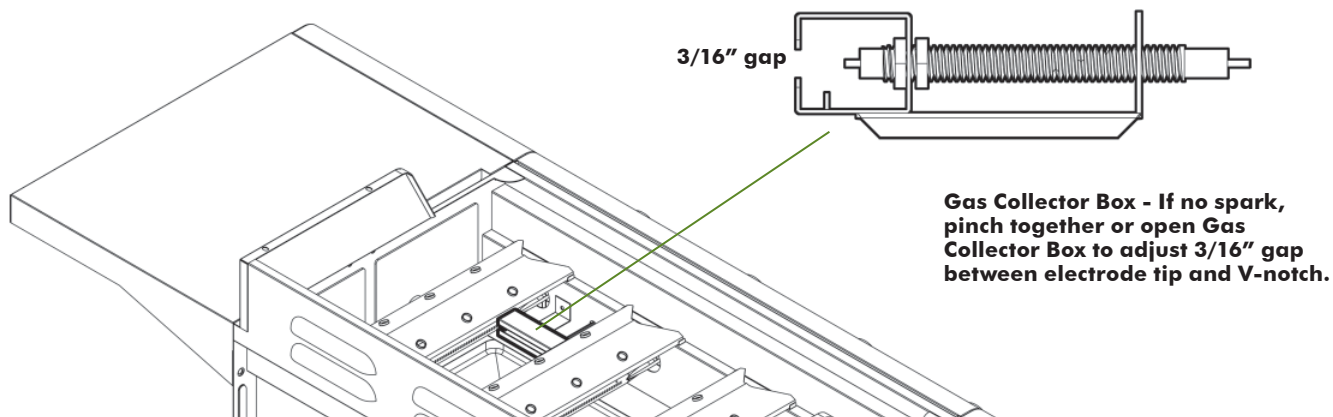

Fig. 10

6. From the "Off" position, light all other Burners from left to right, making sure each Burner is lit before lighting the next. Your grill has a Crossover Ignition System that allows the Burners to light successively off one another. Confirm each Burner is lit before lighting another Burner.
7. If the Burner fails to light, repeat Step 5. If it still does not light, try the next Burner from left to right.

If a Burner goes out during operation, turn all Control Knobs to the "Off" position and close the LP Gas Cylinder valve to dissipate any accumulated gas. Open Hood and wait five minutes before attempting to relight the grill.

If any or all Burners fail to light after three to four attempts following Steps 4-7, turn all Control Knobs to the "Off" position and close the LP Gas Cylinder valve to dissipate any accumulated gas. Wait five minutes; then repeat the lighting procedures.

NOTE: If the Burners still fail to light, refer to the **Troubleshooting Section on page 31**. The Burner can also be lit manually, see **Manual Lighting of the Grill on page 21**.

Manually Lighting the Grill

⚠️ WARNING

To reduce the risk of serious bodily injury or death from fire or explosion:

- Open Hood before lighting the grill to prevent an explosion from gas build-up.

1. Open the Hood.
2. **IMPORTANT:** Make sure Control Knobs are turned "Off." (Fig. 7, P.19)
3. Turn the LP Gas Cylinder valve open counterclockwise until it stops. (Fig. 8, P.19)
4. Locate either the left or right match-lighting hole you intend to use underneath the Grill Bowl. Push in and turn either the far left or far right Main Burner Control Knob, near the match-lighting hole, counterclockwise to the "High" position.
5. Insert a lit match through the match-lighting hole using the match holder (Fig. 11 and 11a) OR through the cooking grates. (Fig. 12)

View from underneath.
Insert lit match
through matchlighting
hole under the left side
burner table using the
match light holder

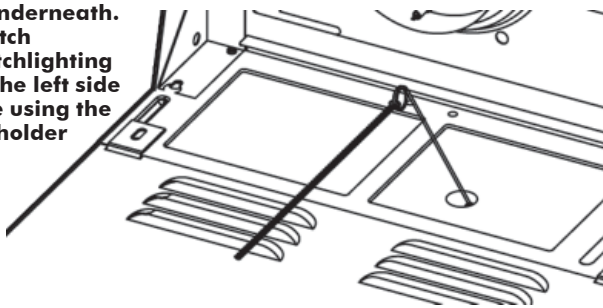

Fig. 11

View of match through hole
from top side of burner.
Shown without Flavor
Activators and
cooking grids.

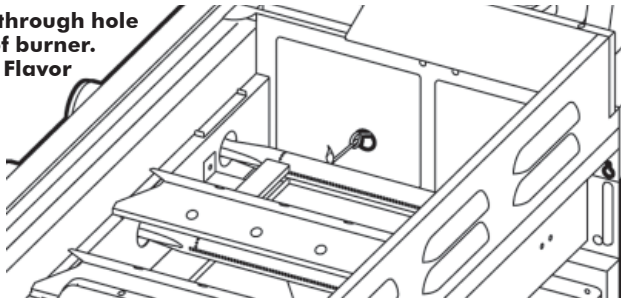
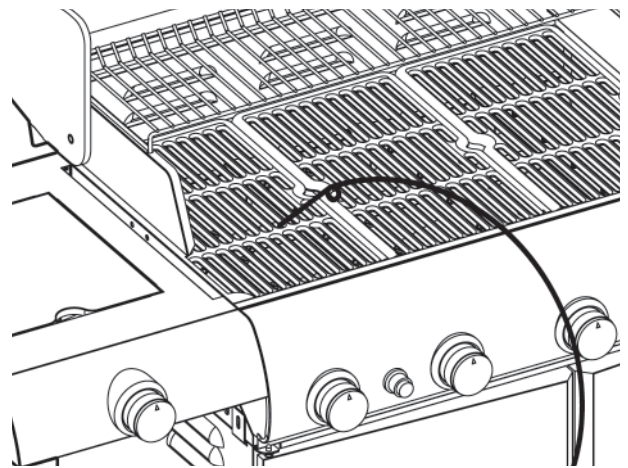

Fig. 11a



View of inserting lit match through the cooking grids.
Each burner may be lit in succession in this method if
necessary.

Fig. 12

6. From the "Off" position, light all other Burners from left or right, making sure each Burner is lit before lighting the next. Your grill has a Crossover Ignition System that allows the Burners to light successively off one another. Confirm each Burner is lit before lighting another Burner.

If any or all Burners fail to light after three or four attempts following Steps 3-5, turn all Control Knobs to the "Off" position and close the LP Gas Cylinder valve to dissipate any accumulated gas. Wait five minutes; then repeat the lighting procedures.

NOTE: If the Burner still fails to light, refer to the **Troubleshooting Section**.

7. After ignition, turn the Control Knobs to "High" for 3-5 minutes and close the Hood to preheat the grill. Preheat the grill before every cooking session.

If a Burner goes out during operation, turn all Control Knobs to the "Off" position and close the LP Gas Cylinder valve to dissipate any accumulated gas. Open Hood and wait five minutes before attempting to relight the grill.

Lighting the Side Burner

WARNING

To reduce the risk of serious bodily injury or death from fire or explosion:

- Open Side Burner Lid before lighting the grill to prevent an explosion from gas build-up.

1. Open the Side Burner Lid. (Fig. 13) **NOTE:** Side Burner Lid is to remain open while the Side Burner is on or hot.
2. **IMPORTANT:** Make sure the Side Burner Control Knob is turned "Off" first. (Fig. 7, P.19)
3. Turn the LP Gas Cylinder valve open counterclockwise until it stops. (Fig. 8, P.19)
4. Push Side Burner Control Knob in and turn counterclockwise to the High position. (Fig. 7, P.19)
5. Push the Igniter Button on the Main Control Panel in until the Burner is lit. Listen for the spark ignition and look to make sure the Burner is lit. If no spark, see **Troubleshooting Section**.
6. If the Burner fails to light, repeat Steps 3-5.

If the Burner fails to light after three or four attempts following Steps 3-6, turn the Side Burner Control Knob to the "Off" position, and close the LP Gas Cylinder valve to dissipate any accumulated gas. Wait five minutes; then repeat the lighting procedures.

NOTE: If the Burners still fail to light, refer to **Troubleshooting Section**. The Burner can be lit manually, see **Manually Lighting the Side Burner**.

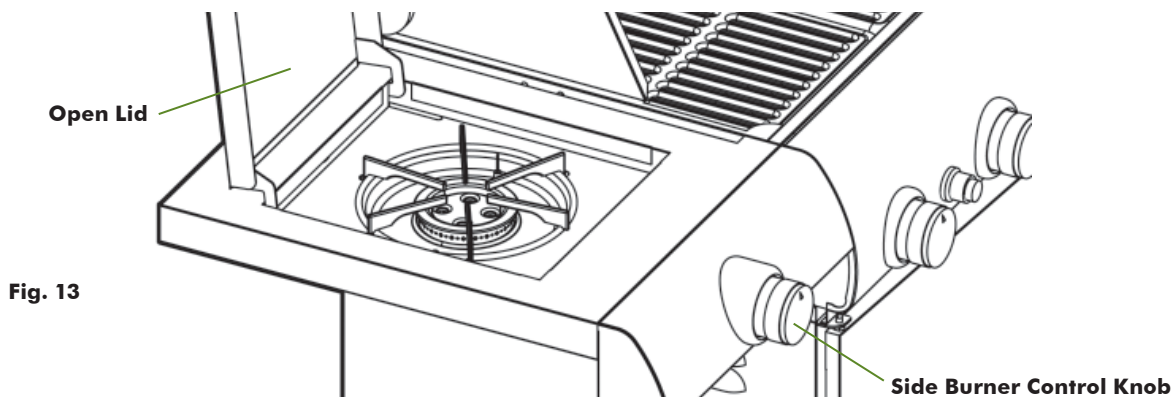

Check The Flame

The Burners have been preset by the manufacturer for optimal flame performance. A blue flame, possibly with a small yellow tip, is the result of the optimal air and gas mixture.

Check the flame before each cooking session and throughout the grilling season. Check the flame especially after long periods of storing the grill. If the flame is significantly yellow in color, the appropriate amount of LP gas in the air/LP gas mixture is not correct. This could be due to a blocked Burner from grease drippings or from insects building a nest inside the Burner or Burner opening. See **How to Clean the Burners**.

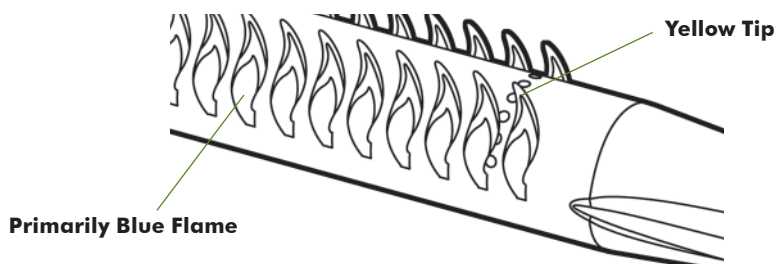

Manually Lighting the Side Burner

WARNING

To reduce the risk of serious bodily injury or death from fire, explosion or burn hazard:

- Open Side Burner Lid before lighting the grill to prevent an explosion from gas build-up.
- When manually lighting Side Burner, use Matchlight Holder.

1. Open the Side Burner Lid.
2. **IMPORTANT:** Make sure Side Burner Control Knob is turned "Off" first.
3. Turn the LP Gas Cylinder valve open counterclockwise until it stops. (Fig. 8, page 19)
4. Push Side Burner Control Knob in and turn counterclockwise to the High position.
5. Hold lit Match, using Match Holder, near Burner.
6. If the Burner fails to light, repeat Steps 3-5.

If the burner fails to light after three or four attempts following Steps 3-6, turn the Side Burner Control Knob to the "Off" position and close the LP Gas Cylinder valve to dissipate an accumulated gas. Wait five minutes; then repeat the lighting procedure.

NOTE: If the Burners still fail to light, refer to **Troubleshooting Section**.

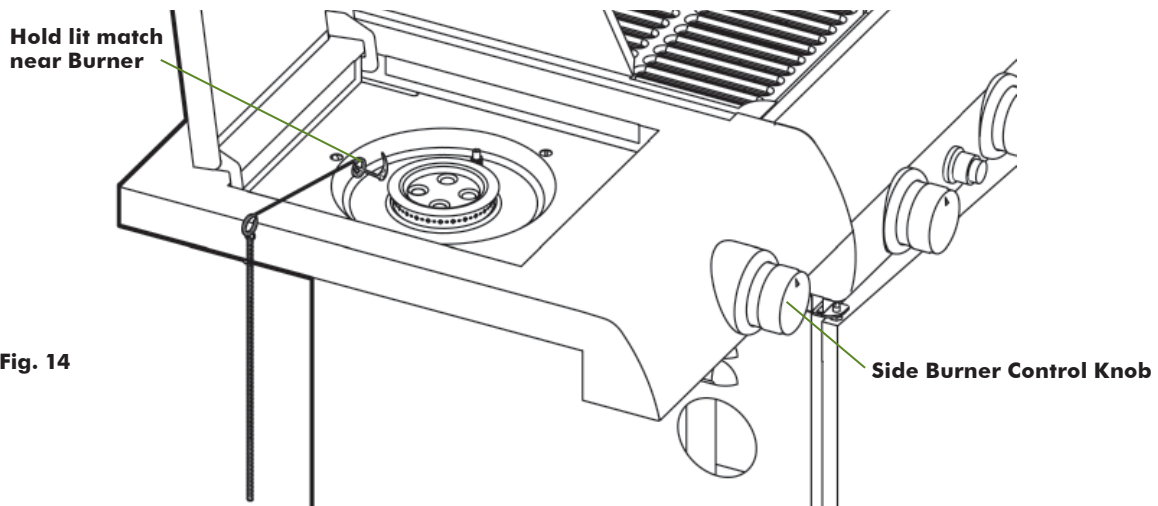

Fig. 14

Cooking On the Gas Grill

WARNING

To reduce the risk of serious bodily injury or death from fire, explosion or burn hazard:

- Never use charcoal or lighter fluid in your gas grill. Keep this outdoor cooking appliance clear and free from combustible materials, gasoline, and other flammable vapors and liquids.
- Keep any electrical supply cord and regulator hose away from any heated surfaces.
- Make sure there are no gas leaks or obstructions to the flow of combustion and ventilation air before each use.
- Keep the ventilation openings of the LP Gas Cylinder enclosure free and clear from debris.
- Always open the Hood before lighting the LP gas grill.
- Do not attempt to extinguish a grease fire with water or other liquids. Have a BC fire extinguisher accessible. Never douse or spray the grill or cooking surfaces with water when hot. Burns from grease or water splatters could occur.
- If your gas grill catches on fire:
 - If the fire is in the grill portion and you can safely reach the Control Knobs on the Control Panel, then turn them to the "Off" position.
 - If the fire is in one of the hoses, and you can safely reach the LP Gas Cylinder valve, then shut the valve off.
 - If the fire involves the LP Gas Cylinder, leave it alone, evacuate the area, and call the Fire Department.
 - If there is any type of fire that threatens either personal safety or endangers property, call the Fire Department.
- Do not use the grill without Bottom Panel and Grease Pan in place. Check the Foil Pan and Grease Pan for build-up. Empty excess grease to avoid a grease fire in the pan.
- If you notice grease or other hot material dripping from the grill onto the valve, hose, or regulator, turn off the gas supply immediately. After the grill has cooled, determine the cause and correct it. After cleaning the valve, hose, and regulator assembly, perform a leak test before continuing use. See **"Performing a Leak Test."**
- Do not operate a gas grill if you have knowledge of or suspect a gas leak.
- Do not wear loose clothing (example: hanging shirt tails, clothing with frills, etc.) around a gas grill while in use or hot.
- Do not lean your body over the gas grill when lighting it or while it is in use or hot.
- Do not touch hot surfaces. Use heat-resistant gloves, long-handled tongs, or cooking mitts at all times, since the grill will become very hot. Open the Hood carefully when cooking to avoid burns from the hot air and steam trapped inside.
- Do not allow children to operate or play near a gas grill. Keep children, animals and bystanders out of the grill area. Do not leave grill unattended.
- Do not move an LP gas grill when in use or hot.
- When grill is not in use, turn off all grill Control Knobs, LP Gas Cylinder valve, and disconnect the LP Gas Cylinder.

Grill Cooking (Direct Method)

WARNING

To reduce the risk of serious bodily injury or death from fire or explosion:

- Do not cover more than half (50%) the cooking area if using griddle plates. Full coverage of cooking area will cause overheating below the plates.
- Always make sure the Foil Pan, Grease Pan, and Bottom Panel are empty and are properly installed under the Bowl before each cooking.
- Do not leave any utensils or cookware on a hot Cooking Grid.

Grill Cooking (Direct Method)

Direct Cooking on the Grids:

Food is cooked directly over the heat source. The Burners heat up the Flavor Activators under the Cooking Grids, which in turn heat the food on the grill. The natural food juices from cooking fall onto the hot Flavor Activators below and vaporize. Rising smoke bastes the food, giving it that unique barbecued flavor.

Use the Direct Cooking method for foods that take less than 25 minutes to cook: steaks, chops, kabobs, sausages, and more.

These foods should be turned once halfway through the grilling time.

To sear meats, place them over Direct High heat for 2 to 5 minutes per side. Smaller pieces require less searing time. Hamburgers, steaks, chops, chicken breasts, and larger cuts of meat all benefit from searing. Usually after searing you finish cooking the food at a lower temperature.

For Direct Cooking, preheat the grill with the Main Burners on "High." Place food on the Cooking Grate, and then adjust all Burners to the temperature required. Close the Hood and lift it only to turn food or to test for doneness at the end of the recommended cooking time.

Cooking on Griddle Plates allows cooking of smaller items that otherwise would fall through the grill. The Burners heat the Griddle Plates directly, which cooks the food on contact. The Griddle Plates sear thin cuts of meat or cook food like eggs that can not be cooked on a grill. They can also be used to heat pans.

CAUTION

Do not preheat Cooking Grids over 5 minutes. The cooking surface coatings could be destroyed.

Use only long-handled heat-resistant plastic or wooden utensils to avoid scratching the non-stick surface.

Roasting (Indirect Method)

WARNING

To reduce the risk of burns from the hot air and steam trapped inside:

- Open the Hood carefully when roasting on grill.

Indirect Cooking (Roasting):

Food is cooked like in an oven under lower heat and/or longer cooking times. These foods require more than 25 minutes grilling time and some are so delicate that Direct Cooking would dry them out or scorch them.

Use the Indirect Cooking Method to cook whole meats such as roasts, ribs, chickens, turkeys, and other large cuts of meat, as well as delicate fish fillets. Place the food to bake or roast on the center of the cooking grids inside a metal baking tray or a disposable heavy-gauge foil pan or on a roasting rack.

Preheat the grill with the Main Burners on "High." Then adjust the Burners lower on each side of the food to the correct temperature and turn "Off" the Burner(s) directly below the food.

Close the hood and cook "indirectly." Monitor the temperature in the Hood Gauge. If the heat gets too high, turn the Burner to the "Low" position. Avoid lifting the Hood frequently, as heat is lost and the cooking time is extended.

For longer cooking times, add water to the Roasting Pan to keep drippings from burning. The drippings can be used to make gravies or sauces.

Rotisserie Cooking

Rotisserie Cooking:

The constant turning of the meat while cooking allows it to self baste with natural juices, making food cooked on the rotisserie exceptionally moist and tender.

The best meats for rotisserie cooking are tightly tied, boned or boneless cuts. Cuts with a bone can be cooked on the rotisserie if they are carefully balanced on the spit so that it can turn easily. When cooking whole poultry, wings and legs should be protected from over browning by tying them securely in place with kitchen string.

Before lighting the barbecue, the cooking grids and warming rack must be removed when the rotisserie is used. Preheat the grill with the Rotisserie Burner on "High." Install the loaded rotisserie spit into the motor and brackets as instructed in the rotisserie kit instruction sheet. Close the hood and cook. Monitor the temperature in the Hood Gauge. If the heat gets too high, turn the Burner to the "Low" position. Avoid lifting the Hood frequently, as heat is lost and the cooking time is extended. Cooking times are similar to conventional ovens.

Use a Meat Thermometer. The only accurate way to tell when meat is done is to use a meat thermometer. Insert the thermometer into the center of the meat. Do not allow the thermometer to touch the bone.

Positioning the Meat. First, assemble the Rotisserie as explained in the kit instruction sheet. To place meat or poultry on the spit, slide one of the spit forks onto the spit with the tines facing the center. Then, insert the spit into the center of the meat or poultry, lengthwise. The food should next be centered on the spit. Secure the meat in place with the remaining spit fork. Tighten the spit forks securely. Test for balance by loosening the counterweight locking mechanism to allow the counterweight to turn freely. Set the rotisserie rod in the slots of the rotisserie brackets. Let the heaviest side of the meat rotate to the bottom. Adjust the counterweight to the side opposite the heaviest side of the meat(up). Tighten the counterweight in place. Periodically, check to see if the meat turns smoothly while cooking. Adjust the counterweight as necessary.

Use a Drip Pan. Place the drip pan on top of the Flavor Activators and position it beneath the center of the food. Put one half to one inch of water, or other cooking liquid in the pan, depending on the flavor that you desire. As the juices and drippings fall, they will mix with the liquid. The mixture vaporizes, rises up and bastes the meat. Do not let the drip pan dry out!

Following are recommendations on how to properly position whole poultry or a leg of lamb on the spit. Many recipes are available in cookbooks and online for seasoning and the preparation of marinades. Marinades should be prepared prior to cooking.

Poultry

With breast down, bring neck skin up over cavity. Turn under edges of skin and skewer to back skin. Loop twine around skewer then turn breast side up and tie wings to body.

Put a spit fork on the spit. Insert rod in neck skin parallel to backbone and push it out just above tail. Slide second fork on spit and insert forks into breast and tail. Test for balance. Tighten all thumb screws.

Tie tail to spit. Cross legs and tie to tail.

When cooking more than one bird at a time, place together with legs to shoulders and tie to each other and to spit with twine. Place spit forks in breast of first bird and tail of second.

Leg of Lamb

Have 3 inches of the bone sawed from the small end of the leg. Leave the meat around the bone intact to form a flap. Put one fork on the spit shaft. Fold flap up and run rod through flap and leg. Put second fork on rod and insert forks in each end of leg. Test for balance. Tighten thumb screws.

Warming Rack

WARNING

To reduce the risk of fire or flare-up from grease drippings:

- When cooking food on the warming rack, make sure no Burners are on directly under the Drip Pan.
- Clean grease drippings away from grill after each use.

Warming Racks are a convenient way to cook food, keep cooked food warm or to warm items such as bread or rolls. To keep foods warm, set the Burners on Low or turn off all that are not needed. When cooking food on the Warming Rack, follow procedures for “Roasting (Indirect Cooking).” Be sure to place a pan or drip tray under the food.

When opening the Hood, be alert of dripping fat from the Warming Rack that could drip onto the back of the grill. Always check that your Warming Rack is properly fitted before use. Wipe away any dripping grease.

End of Cooking Session

WARNING

To reduce the risk of serious bodily injury or death from fire or burn hazard:

- Allow grill and the grease in the Foil Pan to completely cool before emptying, handling parts, cleaning, moving, or storage.
- Empty the Foil Pan and Grease Pan after each cooking session so excessive grease does not accumulate.
- Never light the LP gas grill without the Foil Pan, Grease Pan, and Bottom Panel in place.

1. After each cooking session, close the Hood and turn the Burners to the “High” position and burn for five minutes. This will burn off some cooking residue, thus making cleaning easier. (Side Burner not affected.)
2. When you have finished using your grill, turn the Control Knobs clockwise to the “Off” position.
3. Turn off the gas at the LP Gas Cylinder valve by turning the handle clockwise until it stops.
4. Wait until the grill is cool before closing the Hood, cleaning, or putting on a grill cover.
5. Regularly clean your LP gas grill between uses and after extended storage periods. To maintain the condition and extend the life of your grill, we strongly recommend that the unit be covered when stored outside for any length of time, especially during the winter months.

Care and Maintenance

CAUTION

To reduce the risk of a laceration hazard, wear protective gloves when handling parts that have sharp edges.

Cleaning the Grill

Bottom Panel, Grease Pan, Foil Pan:

Remove the two bolts on the sides securing the Bottom Panel. (Step 14, page 12) Scrape away food and fat residue from the Bottom Panel. Empty and wash the Foil Pan and Grease Pan with hot soapy water and a cloth. The Foil Pan can be replaced with a standard size foil pan. (approx. 5-1/2" W x 8-1/2" L x 1-1/8" H) from your local grocer or retail store or ordered online at www.AussieGrills.com

Grill Body and Cabinet:

Do not mistake the accumulation of grease and smoke residue for peeling or flaking paint. Remove excess grease and/or fat with a soft plastic or wooden scraper. Do not use steel wool or other abrasive cleaners that can scratch painted, porcelain-coated, or stainless steel surfaces. It is not necessary to remove all the grease from the body. Wipe it down with paper towels or soft damp cloth.

Warming Rack:

Clean if necessary.

Cooking Grid/Flavor Activators:

Clean the residue off with a baking soda and water solution. For stubborn stains, use a non-abrasive scouring powder. Do not use steel wool or other abrasive cleaners that can scratch the stainless steel or porcelain-coated surfaces. This can cause foods to stick on the Cooking Grids.

All other Cleaning:

For further cleaning, use hot soapy water and a cloth, or nylon-bristled brush only. Do not immerse the Gas Controls or Manifold in water. (Avoid getting water in the Burner holes.)

Burners:

Burning off the residue after cooking will keep the Burners clean with normal usage, provided the Burners are operating correctly. Clean the Burners annually, or whenever heavy build-up is found, to ensure that there are no signs of blockage (debris, insects) in the Burner portholes, the primary air inlet, or the neck of the Burners. See **How to Clean the Burners**.

After cleaning, replace all the cleaned parts. Re-tighten Bottom Panel bolts.

WARNING

To reduce the risk of death or serious injury from an explosion or a fire beneath the grill:

- Inspect and clean Burner/Venturi Tubes for insects or insect nests. Spiders or small insects can build nests, webs, and lay eggs in the grill's Venturi Tubes, (Fig 15) obstructing the flow of gas to the Burner. The backed-up gas can ignite behind the Control Panel and cause a fire beneath the grill, posing the risk of death or serious bodily injury. This is known as a "flashback."
- Be sure Burners are re-installed properly before using grill.

Should you notice that your Burner(s) are getting hard to light or the flame is not as hot as it once was, refer to the **"How to Clean your Burners"** section to remove any possible obstructions.

In order to prevent flashbacks, the Burner(s) should be removed from the grill and cleaned periodically, especially if the grill has been stored for an extended period of time.

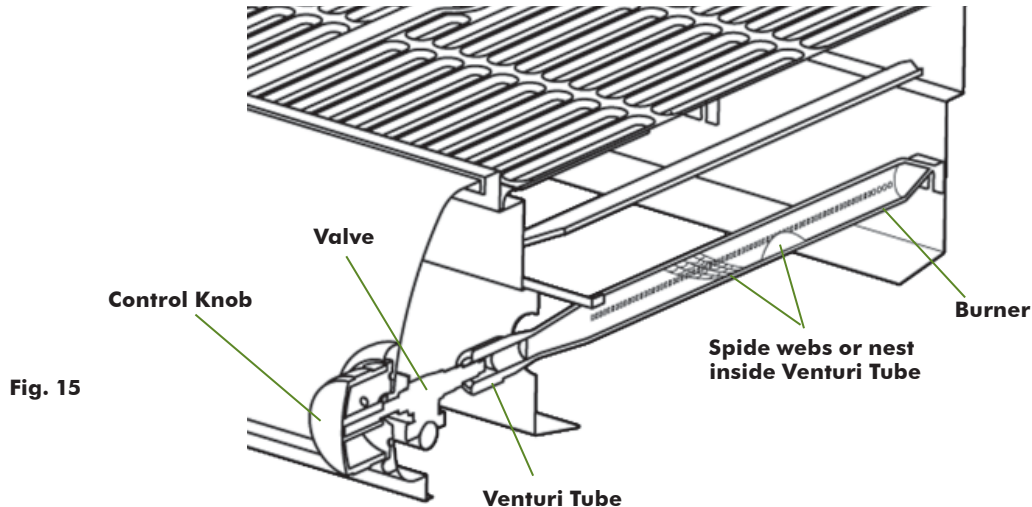

Fig. 15

How to Clean the Burners

1. Make sure the Control Knobs are turned "Off" and the grill is completely cooled.
2. Carefully remove Cooking Grids and Flavor Activators.
3. To remove each Main Burner, first remove the nut & bolt that fastens the burner flange to back wall. (Fig. 16) Leave Side Burner in place.
4. Slide each Main Burner toward the grill front to disengage tab at rear of burner from slot in back wall of bowl. Gently lift the rear of the Burner. (Fig. 17) Slide the Burner towards the grill back to move the Venturi Hole off of the Valve nozzle. (Fig. 18) Lift each Main Burner from the grill.

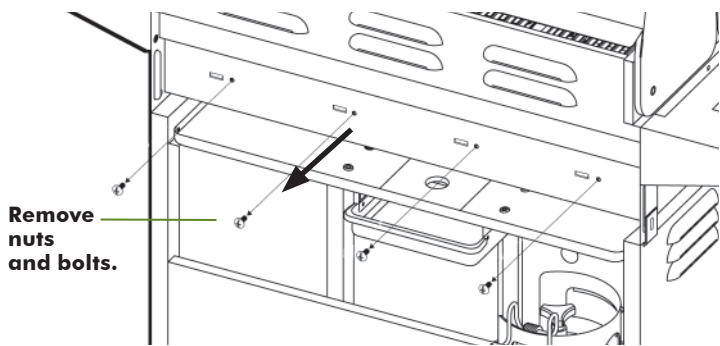

Fig. 16

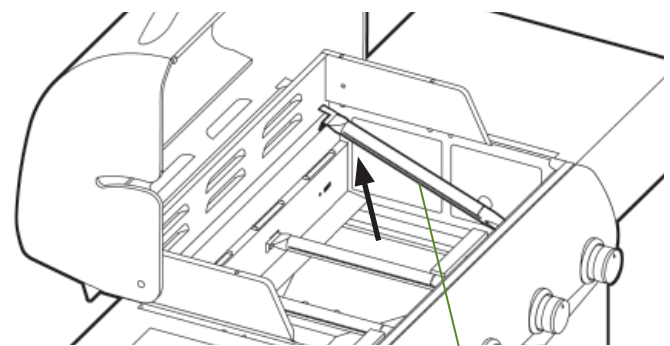

Fig. 17

Lift Burner up and out.

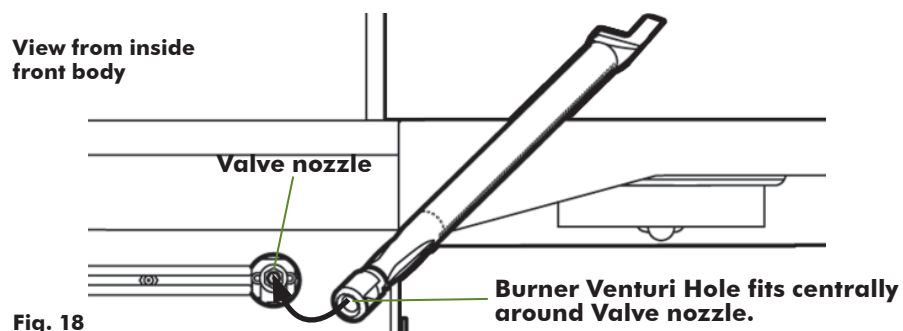
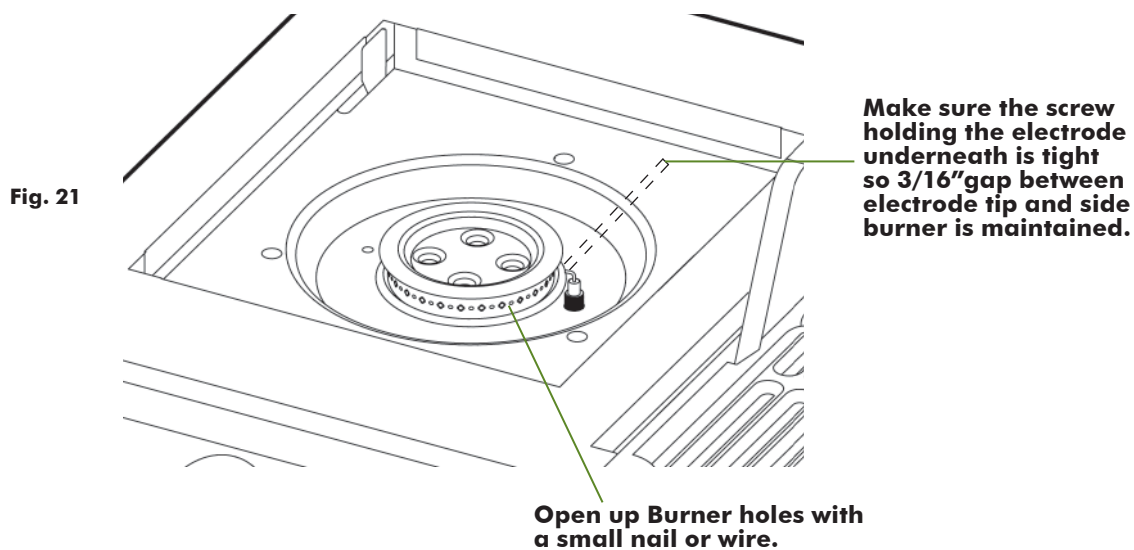
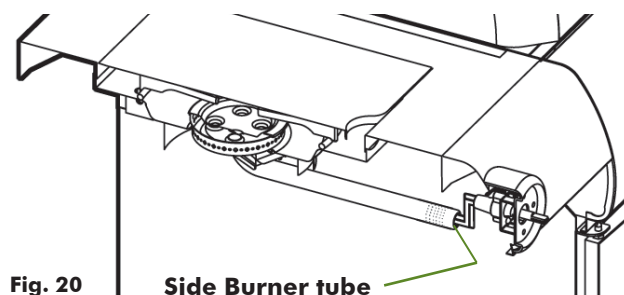
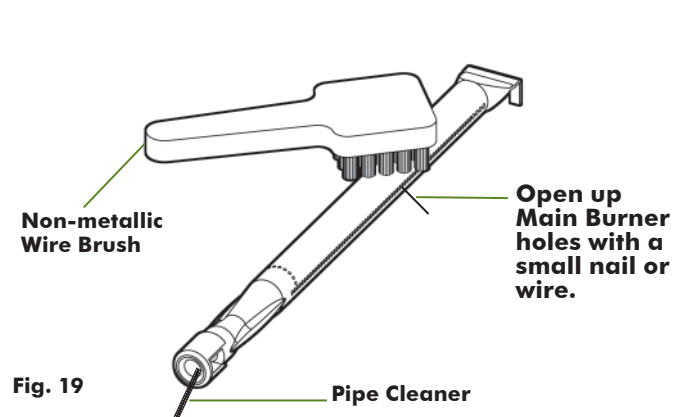

Fig. 18

5. Use a pipe cleaner to clear insect nests from the inlet hole of Main Burner (Fig. 19) and Side Burner tube. (Fig. 20)
6. Open up the Main Burner holes (Fig. 19) and the Side Burner holes (Fig. 21) with a small nail or wire. Use a **non-metallic brush** to remove food particles and corrosion from the Burner surfaces.



7. Check the Side Burner Electrode to see if it is loose. If so, tighten the screw holding the Electrode to maintain 3/16" gap between Electrode tip and Side Burner.

NOTE: Before next step, you may wish to clean the rest of the grill. See **Grill Body and Cabinet** (p. 27).

8. After cleaning, refit the Burners.

NOTE: When refitting the Burners, be sure each Burner is positioned correctly. The valves should protrude inside the Venturi ends of the Burner. (Fig. 18) Replace the Bolts and Nuts that fasten the Burner Flange to Back Wall.

9. If the grill is to be stored, wrap Burners in a protective cover to keep insects out.
10. Check Burner operation after re-assembly.
11. Replace Flavor Activators and Cooking Grids.

Storage

WARNING

To reduce the risk of serious bodily injury or death:

- Store your LP gas grill in a cool dry place. Do not store an LP Gas Cylinder in a space greater than 125 degrees Fahrenheit. Never store a connected LP Gas Cylinder in a building, garage, or any enclosed area.
- Store LP Gas Cylinders outdoors out of reach of children.
- Never store an LP Gas Cylinder indoors (empty or filled) unless it is disconnected from the gas grill and the cylinder's Gas Supply is turned "OFF."
- Never leave an LP Gas Cylinder inside a vehicle that can become overheated by the sun.
- Even though your LP Gas Cylinder may appear to be empty, gas may still be present and the LP Gas Cylinder should be transported and stored accordingly.
- Never store a spare LP Gas Cylinder under or near the LP gas grill.
- Always turn off the LP Gas Cylinder at the LP Gas Cylinder valve when the gas grill is not in use.

1. Disconnect LP Gas Cylinder from grill and store outside, in a dry, well-ventilated area, away from any sources of heat or ignition. Re-cap LP Gas Cylinder valve with the Safety Cap.
2. Remove Burners and wrap with aluminum foil to prevent insects from entering the Burner holes. Store wrapped Burners on top of Cooking Grid.
3. You may wrap the Cooking Grid and Flavor Activators in aluminum foil and place inside the Hood or store inside your dwelling.
4. Place a grill cover over the grill and store outdoors if possible. It may be stored indoors only if the LP Gas Cylinder is disconnected from the gas grill and stored outside.
5. Before next use, remove aluminum foil and reinstall Burners, Flavor Activators, and Cooking Grids.
6. Before using the grill after periods of storage or non-use (i.e. over winter), check your LP gas grill for gas leaks, deterioration, proper assembly, and Burner obstructions.
7. Periodically check and tighten all nuts, bolts, and screws.

Emergencies

Problem	Possible Cause	Solution
Gas leaking from cracked/cut/burned hose	Damaged hose	Turn off gas at the LP Gas Cylinder. Replace valve/hose regulator before continuing use.
Gas leaking from LP Gas Cylinder	Mechanical failure due to rust or mishandling	Replace LP Gas Cylinder.
Gas leaking from LP Gas Cylinder valve	Failure of valve from mishandling or mechanical malfunction	Turn off LP Gas Cylinder valve. Return Cylinder to gas supplier.
Gas leaking between LP Gas Cylinder and regulator connection	Improper installation, connection not tight, failure of seal on LP Gas Cylinder valve	Turn off LP Gas Cylinder valve. Re-install correctly or tighten coupling nut. Replace Cylinder if seal is damaged. See "Leak Test" and "Connecting Regulator to LP Gas Cylinder" sections.
Fire coming through Control Panel	Fire in or around Venturi tube section of Burner	If you can safely reach the Control Panel, turn off Control Knobs, then close the LP Gas Cylinder valve. Once fire is out and grill has cooled off, remove Burner(s) and inspect for blockage from spider webs/insect nests or rust. See "How to Clean Burners" section. Replace any damaged parts.
Grease fire or excessive flames above cooking surface	Too much grease build-up in Burner section	Turn off Control Knobs and LP Gas Cylinder valve. Once fire is out and grill has cooled off. Clean residual food particles and excess grease from inside firebox area, grease cup, and other surfaces.
Flashback (Fire in or around Venturi tubes)	Clogged or blocked Venturi tube	If you can safely reach the Control Panel, turn Control Knobs to "Off," then close the LP Gas Cylinder valve. Clean Burner and Venturi tubes. See "How to Clean Burners" section.

Troubleshooting

Problem	Possible Cause	Solution
Burners will not light using the ignitor	Burners not assembled correctly	See re-assembly after cleaning in "Care and Maintenance."
	Not holding ignitor switch long enough for pulse spark	When lighting the first (LEFT MOST) Burner, push Control Knob in and turn counterclockwise to the "High" position. Depress the Igniter Button until the Burner lights.
	No spark, electrode cracked, broken or loose.	<ol style="list-style-type: none"> 1. Make sure all the wires are connected and to the right terminals. 2. If Electronic, check the battery. Make sure it is pushed in the holder. 3. Gas collector tab is bent (making too large or small of a gap between the Electrode and tab). By hand, bend gas collector tab back within a maximum of 3/16" gap to Electrode. (Page 20) 4. Tighten Electrode mounting screws. 5. Replace damaged Electrodes.
	LP gas cylinder is empty	Take LP Gas Cylinder to licensed LP gas supplier to be refilled.

Problem	Possible Cause	Solution
	Regulator coupling nut is not fully connected to LP cylinder	Tighten coupling nut by hand about one-half to three quarters additional turn. Do not use tools.
	LP-Excess flow valve tripped in regulator	Turn Control Knobs to "Off" position and turn LP Gas Cylinder handle clockwise until it stops. Wait five minutes. Relight LP gas grill. If flame continues to be low, turn off gas at LP Gas Cylinder and grill. Disconnect the regulator from the LP Gas Cylinder. Reconnect the regulator to the LP Gas Cylinder. This will reset the excess flow valve Perform a leak test. Relight grill.
	Vapor lock in connections	
	Obstructions in Burners	Clean the Burners. See "How to Clean Burners" in Care and Maintenance .
	Wet Electrodes and Burners	Dry Electrode with clean cloth. Air dry or use blow dryer.
	Wire loose or disconnected	Reconnect the wire.
	Wire shorting (sparking between Igniter and Electrode)	Replace Igniter Wire/Electrode assembly. (Call the Customer Service Department)
Burners will not light using a match	Burners not assembled correctly	See re-assembly after cleaning in Care and Maintenance .
	LP Gas Cylinder is empty	Take LP Gas Cylinder to licensed LP gas supplier to be refilled.
	LP-Excess flow valve tripped in regulator	Turn Control Knobs to "Off" position and turn LP Gas Cylinder handle clockwise until it stops. Wait five minutes. Relight LP gas grill. If flame continues to be low, turn off gas at LP Gas Cylinder and grill. Disconnect the regulator from the LP Gas Cylinder. Reconnect the regulator to the LP Gas Cylinder. This will reset the excess flow valve Perform a leak test. Relight grill.
	Regulator Coupling nut is not fully connected to LP Gas Cylinder	Tighten Regulator Coupling nut by hand about one-half to three quarters additional turn. Do not use tools.
	Obstructions in Burners	See "How to Clean Burners" in Care and Maintenance .
Low flame or low heat	LP-gas in LP Gas Cylinder is low	Check LP Gas Cylinder. Refill if necessary.
	Excess flow valve tripped in regulator	Turn Control Knobs to "Off" position and turn LP Gas Cylinder handle clockwise until it stops. Wait five minutes. Relight LP gas grill. If flame continues to be low, turn off gas at LP Gas Cylinder and grill. Disconnect the regulator from the LP Gas Cylinder. Reconnect the regulator to the LP Gas Cylinder. This will reset the excess flow valve Perform a leak test. Relight grill.
Flames blow out	High or gusting winds	Turn front of grill away from wind or increase flame height.
	Gas in LP cylinder is low	Check LP Gas Cylinder. Refill if necessary.
	Excess flow valve tripped	See "Low flame" problem above.

Problem	Possible Cause	Solution
Flare up	Grease build-up	Clean grill.
	Excessive fat in meat	Trim fat from meat before grilling.
Persistent grease fire	Grease trapped around burner system	Turn Control Knobs "Off" and turn handle of LP Gas Cylinder clockwise until it stops. Open Hood carefully and let fire burn out. After the grill cools, remove and clean all parts.
Unable to fill LP tank	Some dealers have older fill nozzles with worn threads	The worn nozzles do not have enough "bite" to engage the valve. Try another licensed LP dealer.
Humming or whistling from regulator	Outside temperature, humidity, barometric pressure, and the gas level within the tank may cause the rubber diaphragm inside the regulator to vibrate, making a humming or whistling sound.	Although this sound may be alarming, this is NOT dangerous as long as it is not accompanied by the smell of gas. Simply adjust the Burner settings, and usually the sound will subside. If the humming sound persists, a change in atmospheric conditions will eventually stop the vibration.
Cabinet doors do not close	Doors magnets loose.	Tighten Door Magnet bolts and nuts.
	Doors not aligned.	<ol style="list-style-type: none"> 1. Loosen bolts and bottom door brackets. Align doors 2. Loosen bottom side panel bolts inside cabinet. Apply pressure to one side until doors are aligned. Retighten bolts.

If your problem is not resolved from the information provided above, please call Customer Service at 1-800-251-7558. If you need a replacement part under warranty, a proof of purchase will be necessary.

IMPORTANT NOTICE

The Gas Grill is set up to operate with a LP Gas Cylinder equipped with an OPD (Overfill Prevention Device).

This is a secondary device to prevent overfilling your LP Gas Cylinder. The proper methods for the filling of your LP Gas Cylinder are by weight or volume, as described in NFPA 58. Please make sure your filling station fills your LP Gas Cylinder by weight or volume. Ask your filling station to read purging and filling instructions on the LP Gas Cylinder before attempting to fill.

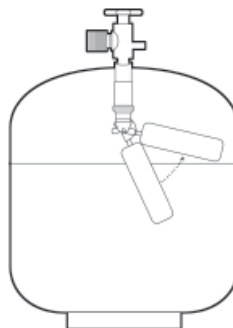

Rises up while filling, then stops when full.

! WARNING

Do not exchange the LP Gas Cylinder unless the exchange LP Gas Cylinder is equipped with an OPD. Otherwise you will lose the OPD (Overfill Prevention Device) feature. If there is not an LP Gas Cylinder available for exchange equipped with an OPD, we recommend that you have your LP Gas Cylinder filled at an authorized LP gas dealer by a qualified attendant.

Parts Illustration

If you need replacement parts, refer to the Parts Illustrations to find the exact parts you need. If you have any questions or need help, contact **Customer Service at 1-800-251-7558** or go to **www.aussiegrills.com**. Be sure to have the grill model number and serial number printed on the black label, located inside the left door of the cabinet. **If you need a replacement part under warranty, a proof of purchase will be necessary.** You will be asked to forward your proof of purchase via e-mail or to fax your proof of purchase to 423-639-1055 and reference your model and serial number. **It is important to register your grill and retain your receipt.**

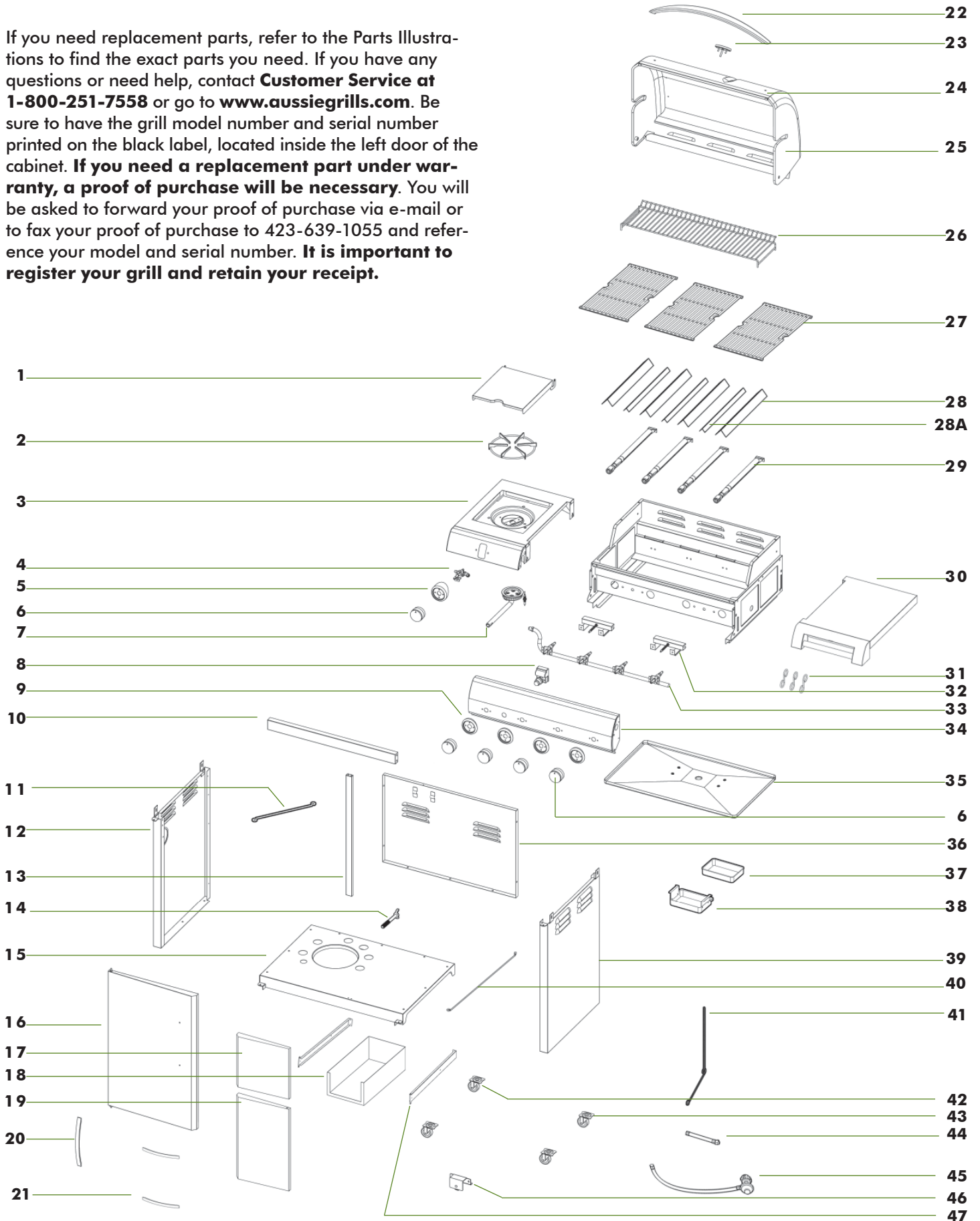

Parts List

Key	Description	Quantity
1	Side Burner Cover	1
2	Side Burner Cooking Grid	1
3	Left Side Table	1
4	Side Burner Valve	1
5	Side Burner Knob Bezel	1
6	Control Knob	5
7	Side Burner	1
8	Ignition Box	1
9	Main Knob Bezel	4
10	Front Crossbar	1
11	Cylinder Wire guard	1
12	Cabinet Side Panel- LEFT	1
13	Cabinet Upright	1
14	Cylinder Retainer Bolt	1
15	Cabinet Bottom Panel	1
16	Cabinet Door- LEFT	1
17	Drawer Front	1
18	Drawer Box	1
19	Cabinet Door- RIGHT	1
20	Handle-Large Door	1
21	Handle-Small Door/Drawer	2
22	Hood Handle	1
23	Thermometer	1
24	Hood Bumper	2
25	Hood	1
26	Warming Rack	1
27	Main Cooking Grid	3
28	Large Flavor Activator	4
28A	Small Flavor Activator	3
29	Main Burner	4
30	Right Side Table	1
31	Tool Hooks	3
32	Electrode Assembly	2
33	Manifold Assembly	1
34	Control Panel	1
35	Bottom Body Panel	1
36	Cabinet Back Panel	1
37	Foil Pan	1
38	Grease Pan	1
39	Cabinet Side Panel- RIGHT	1
40	Cylinder Blocking Wire	1
41	Match Holder/Chain	1
42	Caster, Fixed	2
43	Caster, Locking Swivel	2
44	Manifold to SB valve Hose	1
45	Regulator	1
46	Center Wheel	1
47	Drawer Tracks	2

NOTE: Some illustrations may vary slightly depending on grill Model, however the names are the same.

When ordering parts, it is **VERY important to have the complete Model Number** to be assured of receiving the correct replacement parts for your grill.

48	1/4-20 x .50" S/S Bolt	27
49	1/4-20 S/S Hex Nut	9
50	1/4-20 x .60" S/S Bolt	16
51	5/32 x .47" S/S Bolt	4
52	5/32 x .31" S/S Bolt	37
54	5/32 S/S Hex Nut	1
55	Side Burner Electrode	1 (no pic)

MECO CORPORATION - LIMITED WARRANTY

This product is warranted to the original consumer purchaser against defects in material and workmanship under normal outdoor household use and correct assembly (if assembled by the consumer purchaser). Burners are warranted for a period of two (2) years from the date of purchase. Stainless steel parts are warranted for a period of one (1) year (for rust-through only) from the date of purchase. All other parts are warranted for a period of one (1) year from the date of purchase. MECO CORPORATION DOES NOT warrant in any way the propane cylinder (see label on cylinder for cylinder manufacturer's warranty.) The LP Cylinder manufacturer is responsible for the materials, workmanship, and performance of the cylinder. If the cylinder has a defect, malfunctions, or you have a question regarding the cylinder, call the cylinder manufacturer's customer service center. The phone number is on the cylinder. If the cylinder manufacturer has not resolved the issue to your satisfaction, then call MECO CORPORATION at the customer service number listed below.

MECO CORPORATION requires proof of purchase and we suggest that you keep your receipt. If you need a replacement part under warranty, a proof of purchase will be necessary. Damages caused by commercial or institutional use, accidental or intentional damage, repairs made or attempted by unauthorized persons, or misuse are not covered by this warranty. If defective, the part or product will be repaired or replaced at the option of MECO CORPORATION without charge.

This warranty does not include the cost of any inconvenience or property damage due to failure of the product and does not cover damage due to misuse, abuse, accident, damage arising out of transportation of the product, damage incurred through commercial use, or failure to perform normal and routine maintenance. LIABILITY FOR CONSEQUENTIAL PROPERTY OR COMMERCIAL DAMAGES ARE EXPRESSLY EXCLUDED BY THIS WARRANTY. ANY APPLICABLE IMPLIED WARRANTIES OF MERCHANTABILITY AND FITNESS ARE LIMITED IN DURATION TO THE PERIOD COVERAGE OF THIS EXPRESS WRITTEN LIMITED WARRANTY. Some states do not allow limitation on how long an implied warranty lasts, so this limitation may not apply to you.

Deterioration or damage due to severe weather conditions such as hail, hurricanes, earthquakes or tornados, discoloration due to exposure to chemicals either directly or in the atmosphere, is not covered by this limited warranty.

If grill was purchased "as-is", missing parts will be made available through purchase only.

No returns will be accepted without prior authorization from MECO CORPORATION. Authorization for return may be obtained by calling 1-800-251-7558. Handling and transportation costs for returning the product are not covered by this warranty and will be paid for by the purchaser. Please send your correspondence to

MECO CORPORATION

Attn: Customer Service

1500 Industrial Road

Greeneville, TN 37745

For reference and correspondence,
record your Serial number here.
(See nameplate inside of grill.)

Serial No. _____
Please use this number in registering your warranty and any
correspondance with MECO CORPORATION