

ELITE™ SERIES

The Chamberlain Group, Inc.
845 Larch Avenue
Elmhurst, Illinois 60126-1196
www.liftmaster.com



SECURITY+® GARAGE DOOR OPENER

Model 3850

For Residential Use Only

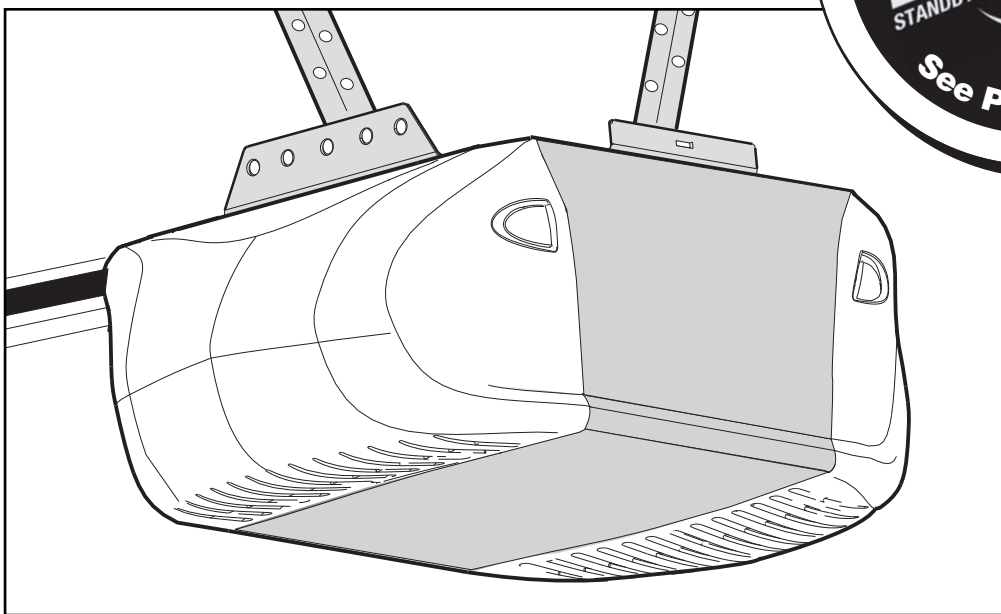

Owner's Manual

- Please read this manual and the enclosed safety materials carefully!
- Fasten the manual near the garage door after installation.
- The door **WILL NOT CLOSE** unless the Protector System® is connected and properly aligned.
- Periodic checks of the opener are required to ensure safe operation.
- The model number label is located under the light lens on the left side panel of your opener.

TABLE OF CONTENTS

Introduction	2-5	Operation	26-33
Safety symbol and signal word review	2	Operation safety instructions	26
Preparing your garage door	3	Using your garage door opener	26
Tools needed	3	Using the wall-mounted door control	27
Planning	4	Using the remote control	28
Carton inventory	5	Troubleshooting	28
Hardware inventory	5	The remote control battery	28
Assembly	6-7	Standby Power (optional)	29
Attach the rail to the motor unit	6	To open the door manually	30
Set the belt tension	6	Care of your opener	30
Attach the belt cap retainer	7	Having a problem? (Troubleshooting)	31
Installation	7-22	Diagnostic chart	32
Installation safety instructions	7	Smart Control Panel™ messages	33
Determine the header bracket location	8	Programming	34-35
Install the header bracket	9	To add or reprogram a hand-held remote control	34
Attach the rail to the header bracket	10	To erase all codes from motor unit memory	34
Position the opener	11	3-Button remotes	34
Hang the opener	12	To add, reprogram or change a Keyless Entry PIN	35
Install the Smart Control Panel™	13	Repair Parts	36-37
Install the Standby Power (optional)	14	Rail assembly parts	36
Install the lights	14	Installation parts	36
Attach the emergency release rope and handle	15	Motor unit assembly parts	37
Electrical requirements	15	Accessories	38
Install the Protector System® (Safety Sensors)	16-18	Notes	39
Fasten the door bracket	19-20	Repair Parts and Service	40
Connect door arm to trolley	21-22	Warranty	40
Adjustment	23-25		
Program the travel limits	23		
Setting the force	24		
Test the safety reversal system	25		
Test the Protector System® (Safety Sensors)	25		

INTRODUCTION

Safety Symbol and Signal Word Review

This garage door opener has been designed and tested to offer safe service provided it is installed, operated, maintained and tested in strict accordance with the instructions and warnings contained in this manual.

 **WARNING**

Mechanical

 **WARNING**

Electrical

CAUTION

When you see these Safety Symbols and Signal Words on the following pages, they will alert you to the possibility of **serious injury or death** if you do not comply with the warnings that accompany them. The hazard may come from something mechanical or from electric shock. Read the warnings carefully.

When you see this Signal Word on the following pages, it will alert you to the possibility of damage to your garage door and/or the garage door opener if you do not comply with the cautionary statements that accompany it. Read them carefully.

Preparing your garage door

Before you begin:

- Disable locks.
- Remove any ropes connected to garage door.
- **Complete the following test** to make sure your garage door is balanced and is not sticking or binding:
 1. Lift the door about halfway as shown. Release the door. If balanced, it should stay in place, supported entirely by its springs.
 2. Raise and lower the door to see if there is any binding or sticking.

If your door binds, sticks, or is out of balance, call a trained door systems technician.

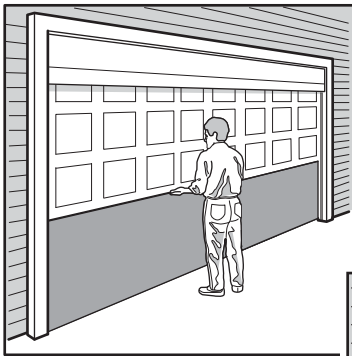

Sectional Door

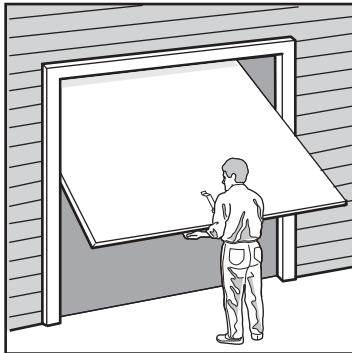

One-Piece Door

WARNING

To prevent possible **SERIOUS INJURY** or **DEATH**:

- **ALWAYS** call a trained door systems technician if garage door binds, sticks, or is out of balance. An unbalanced garage door may not reverse when required.
- **NEVER** try to loosen, move or adjust garage door, door springs, cables, pulleys, brackets or their hardware, **ALL** of which are under **EXTREME** tension.
- Disable **ALL** locks and remove **ALL** ropes connected to garage door **BEFORE** installing and operating garage door opener to avoid entanglement.

CAUTION

To prevent damage to garage door and opener:

- **ALWAYS** disable locks **BEFORE** installing and operating the opener.
- **ONLY** operate garage door opener at 120V, 60 Hz to avoid malfunction and damage.

Tools needed

During assembly, installation and adjustment of the opener, instructions will call for hand tools as illustrated below.

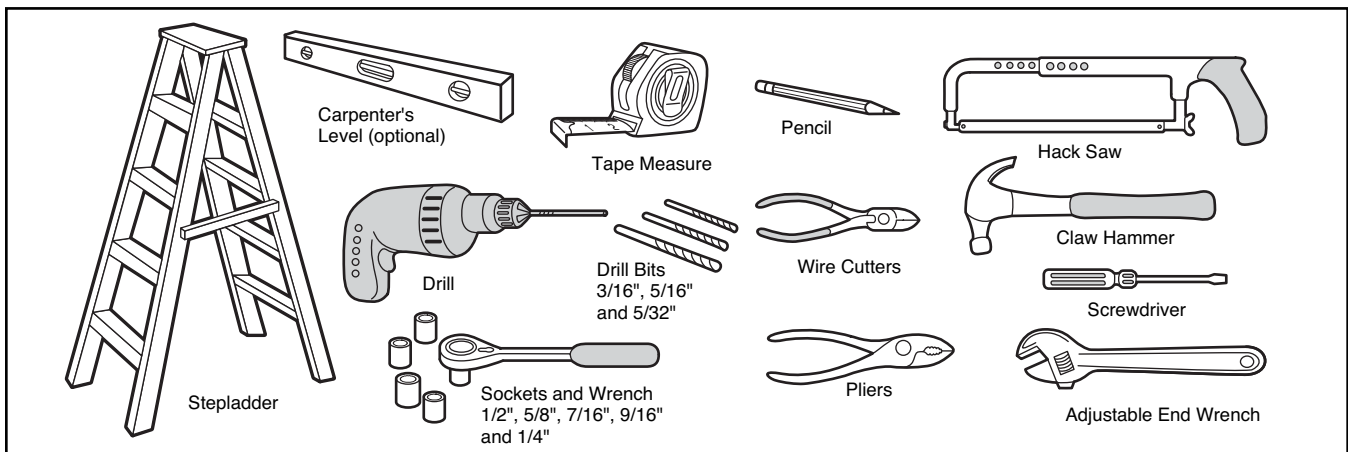

Planning

Identify the type and height of your garage door. Survey your garage area to see if any of the conditions below apply to your installation. Additional materials may be required. You may find it helpful to refer back to this page and the accompanying illustrations as you proceed with the installation of your opener.

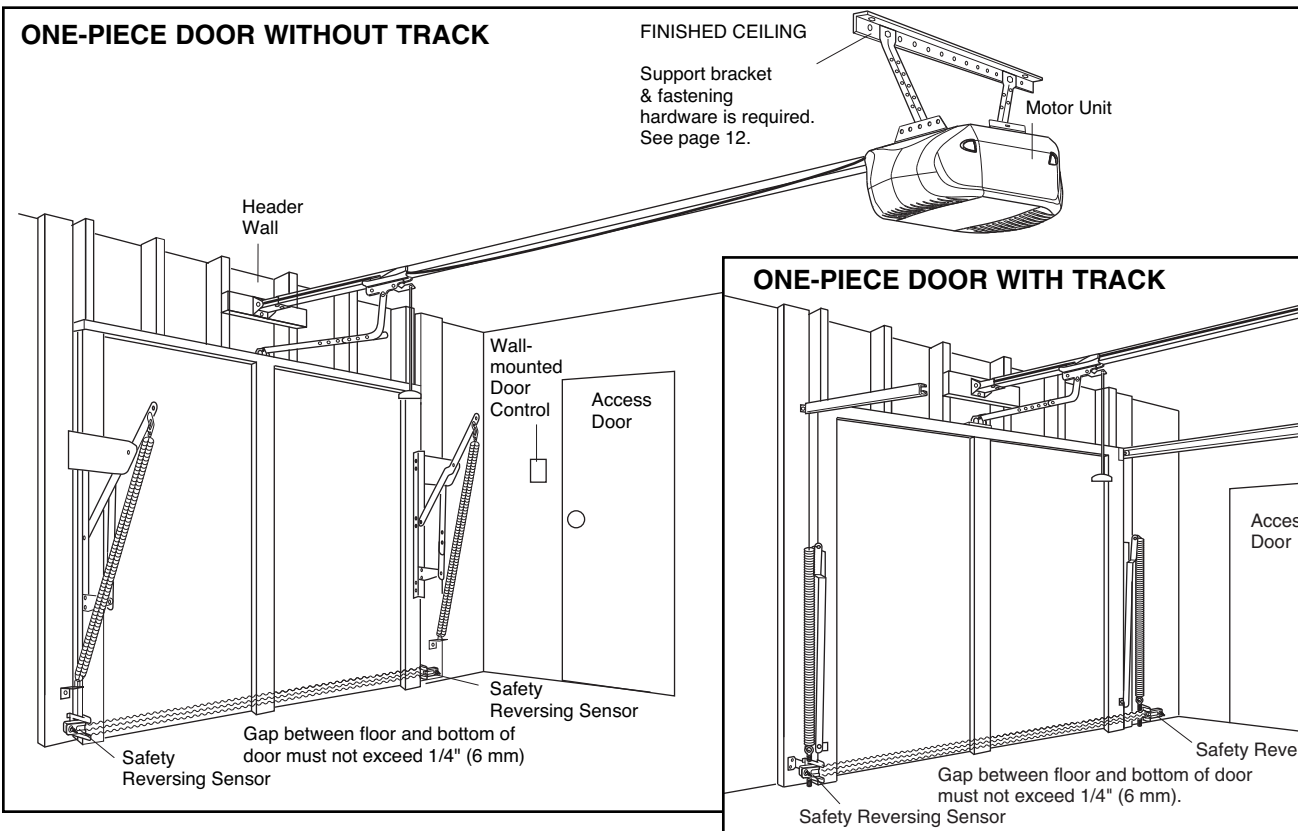
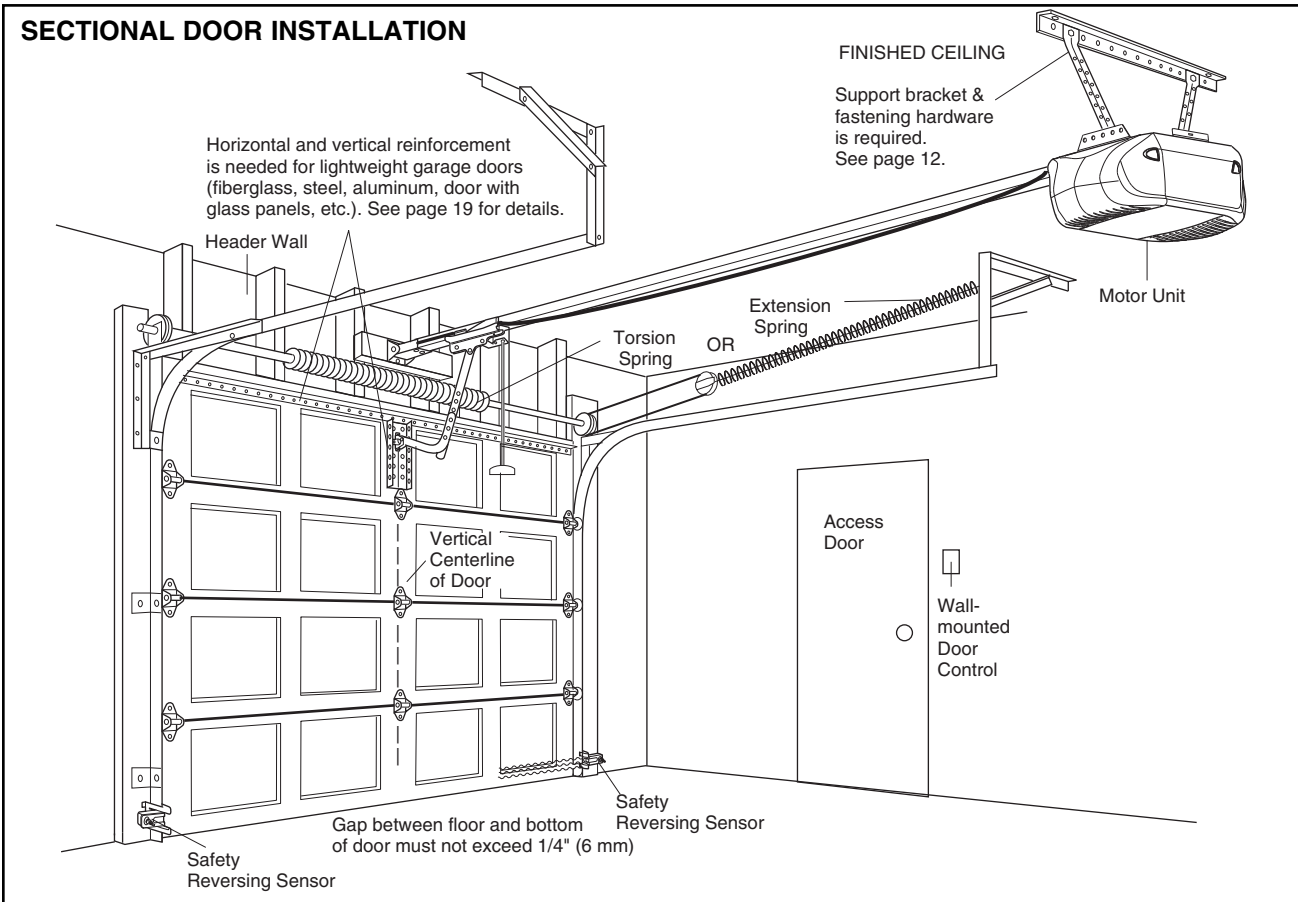

Carton Inventory

Your garage door opener is packaged in two cartons which contain the motor unit and all parts illustrated below. Accessories will depend on the model purchased.

If anything is missing, carefully check the packing material. Parts may be stuck in the foam. Hardware for installation is also listed below.

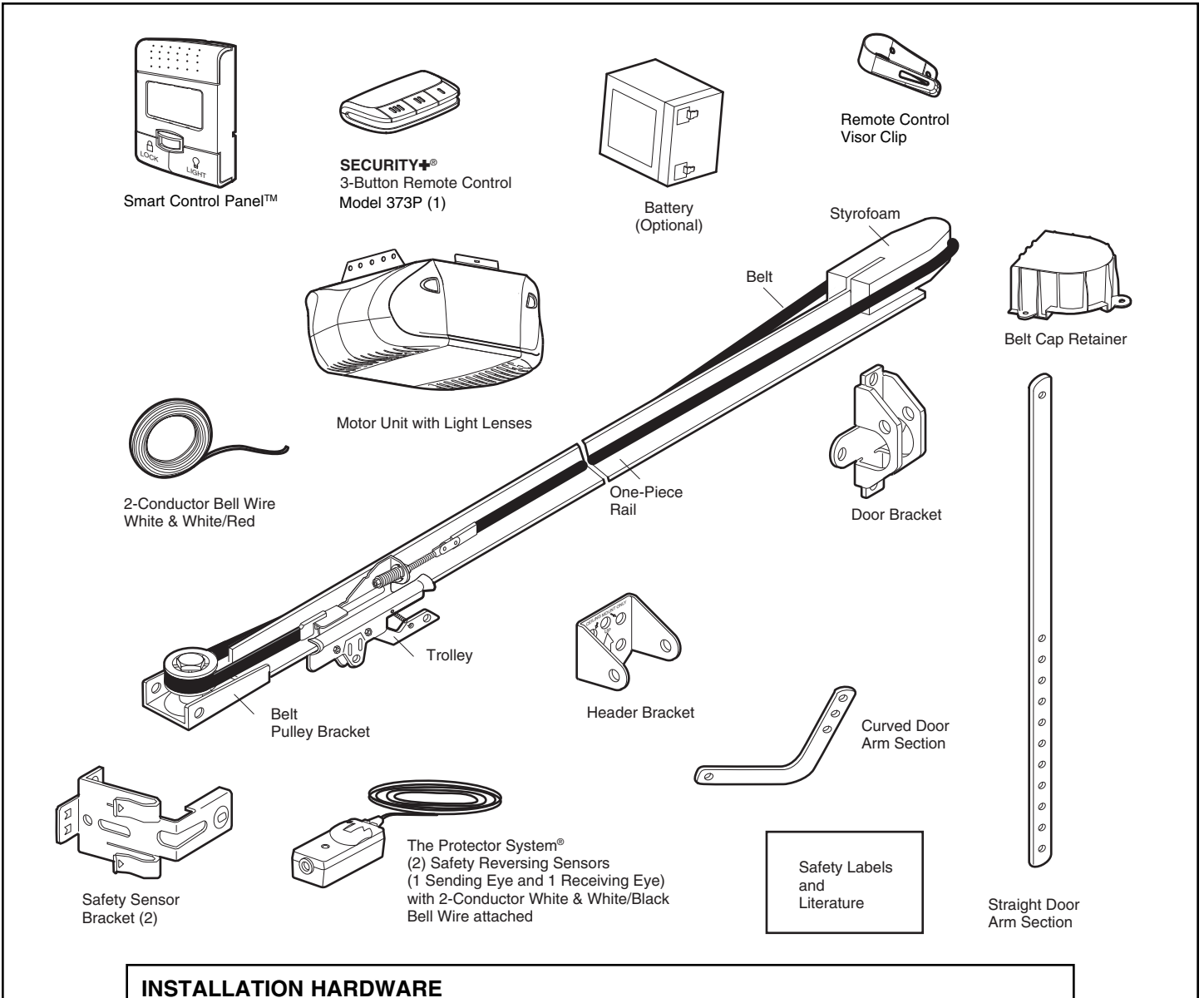

INSTALLATION HARDWARE

Hex Bolt 5/16"-18x7/8" (4)

Hex Screw #8 x 3/8" (2)

Lag Screw 5/16"-9x1-5/8" (2)

Lag Screw 5/16"-18x1-7/8" (2)

Clevis Pin 5/16"x2-3/4" (1)

Clevis Pin 5/16"x1-1/4" (1)

Clevis Pin 5/16"x1" (1)

Nut 5/16"-18 (4)

Lock Washer 5/16" (4)

Screw 6ABx1-1/4" (2)

Self-Threading Screw 1/4"-14x5/8" (2)

Screw 6-32x1" (2)

Insulated Staples (30)

Ring Fastener (3)

Dry Wall Anchors (2)

Rope

Handle

Rail Grease

Carriage Bolt 1/4"-20x1/2" (2)

Wing Nut 1/4"-20 (2)

ASSEMBLY STEP 1

Attach the Rail to the Motor Unit

To avoid installation difficulties, do not run the garage door opener until instructed to do so.

- Remove the two washered bolts mounted on top of motor unit.
- Align rail and styrofoam over belt pulley. Cut tape from rail, chain and styrofoam.
- REMOVE STYROFOAM.
- Insert both washered bolts through the rail into the motor unit. Tighten bolts securely.

Use only these bolts! Use of any other bolts will cause serious damage to door opener.

- Position belt over the motor unit belt pulley.

CAUTION

To avoid **SERIOUS** damage to opener, **ONLY** use bolts mounted in top of motor unit.

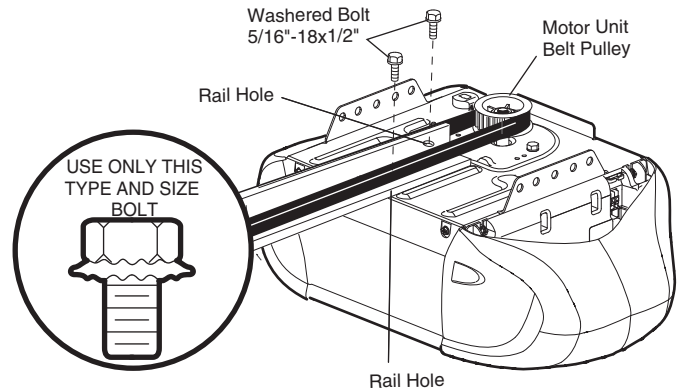

ASSEMBLY STEP 2

Set the Belt Tension

- By hand, thread the spring trolley nut on the threaded shaft until it is finger tight against the trolley (Figure 1). Do not use any tools.
- Insert a screwdriver tip into one of the nut ring slots and brace it firmly against the trolley (Figure 2).
- Place a 7/16" open end wrench on the square end. Rotate about 1/4 turn until the spring releases and snaps the nut ring against the trolley (Figure 3).

This extends the spring for optimum belt tension.

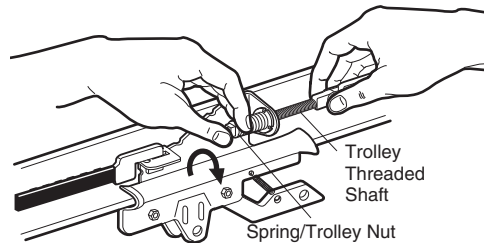

Figure 1

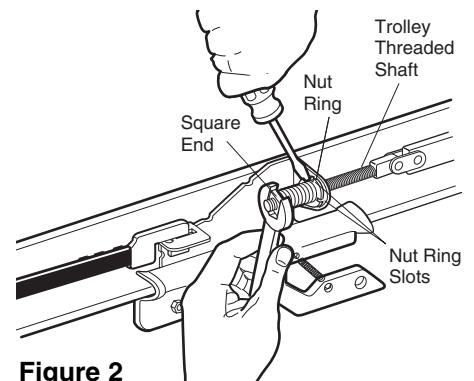

Figure 2

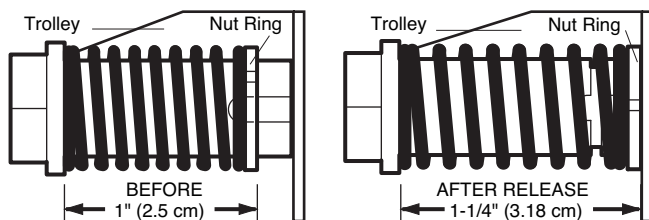

Figure 3

ASSEMBLY STEP 3

Attach the Belt Cap Retainer

- Position the belt cap retainer over the motor unit belt pulley so the three holes in cap align with the three holes in mounting plate. Attach with #8x3/8" hex screws provided.

You have now finished assembling your garage door opener. Please read the following warnings before proceeding to the installation section.



⚠ WARNING

To avoid possible **SERIOUS INJURY** to fingers from moving garage door opener:

- **ALWAYS** keep hand clear of belt pulley while operating opener.
- Securely attach belt pulley cover **BEFORE** operating.

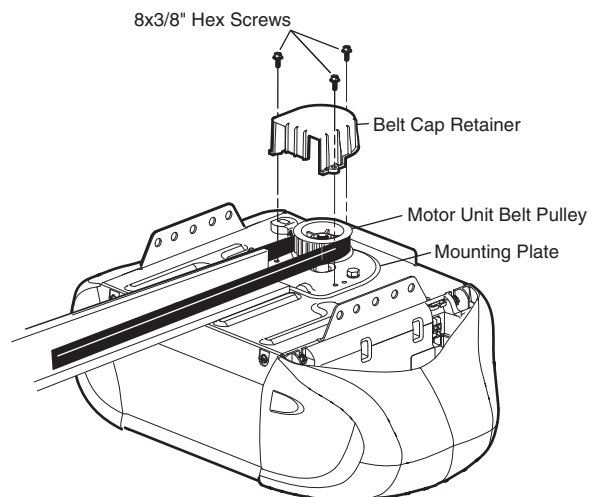

INSTALLATION

IMPORTANT INSTALLATION INSTRUCTIONS

⚠ ⚠ WARNING

To reduce the risk of **SEVERE INJURY** or **DEATH**:

1. READ AND FOLLOW ALL INSTALLATION WARNINGS AND INSTRUCTIONS.
2. Install garage door opener **ONLY** on properly balanced and lubricated garage door. An improperly balanced door may not reverse when required and could result in **SEVERE INJURY** or **DEATH**.
3. **ALL** repairs to cables, spring assemblies and other hardware **MUST** be made by a trained door systems technician **BEFORE** installing opener.
4. Disable **ALL** locks and remove **ALL** ropes connected to garage door **BEFORE** installing opener to avoid entanglement.
5. Install garage door opener 7 feet (2.1 m) or more above floor.
6. Mount emergency release handle 6 feet (1.8 m) above floor.
7. **NEVER** connect garage door opener to power source until instructed to do so.
8. **NEVER** wear watches, rings or loose clothing while installing or servicing opener. They could be caught in garage door or opener mechanisms.
9. Install wall-mounted garage door control:
 - within sight of the garage door.
 - out of reach of children at minimum height of 5 feet (1.5 m).
 - away from **ALL** moving parts of the door.
10. Place entrapment warning label on wall next to garage door control.
11. Place manual release/safety reverse test label in plain view on inside of garage door.
12. Upon completion of installation, test safety reversal system. Door **MUST** reverse on contact with a 1-1/2" (3.8 cm) high object (or a 2x4 laid flat) on the floor.
13. To avoid **SERIOUS PERSONAL INJURY** or **DEATH** from electrocution, disconnect **ALL** electric and battery power **BEFORE** performing **ANY** service or maintenance.

INSTALLATION STEP 1

Determine the Header Bracket Location

WARNING

To prevent possible SERIOUS INJURY or DEATH:

- Header bracket **MUST** be RIGIDLY fastened to structural support on header wall or ceiling, otherwise garage door might not reverse when required. **DO NOT** install header bracket over drywall.
- Concrete anchors **MUST** be used if mounting header bracket or 2x4 into masonry.
- NEVER try to loosen, move or adjust garage door, springs, cables, pulleys, brackets, or their hardware, ALL of which are under EXTREME tension.
- ALWAYS call a trained door systems technician if garage door binds, sticks, or is out of balance. An unbalanced garage door might not reverse when required.

Installation procedures vary according to garage door types. Follow the instructions which apply to your door.

1. Close the door and mark the inside vertical centerline of the garage door.

2. Extend the line onto the header wall above the door.

You can fasten the header bracket within 4' (1.22 m) of the left or right of the door center only if a torsion spring or center bearing plate is in the way; or you can attach it to the ceiling (see page 9) when clearance is minimal. (It may be mounted on the wall upside down if necessary, to gain approximately 1/2" (1 cm)).

If you need to install the header bracket on a 2x4 (on wall or ceiling), use lag screws (not provided) to securely fasten the 2x4 to structural supports as shown here and on page 9.

3. Open your door to the highest point of travel as shown. Draw an intersecting horizontal line on the header wall above the high point:

- 2" (5 cm) above the high point for sectional door and one-piece door with track.
- 8" (20 cm) above the high point for one-piece door without track.

This height will provide travel clearance for the top edge of the door.

NOTE: If the total number of inches exceeds the height available in your garage, use the maximum height possible, or refer to page 9 for ceiling installation.

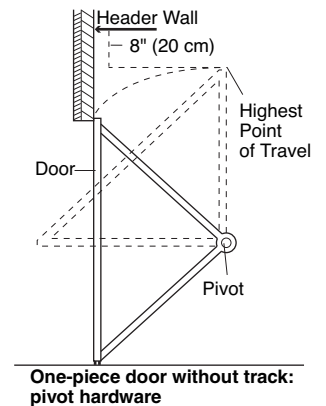
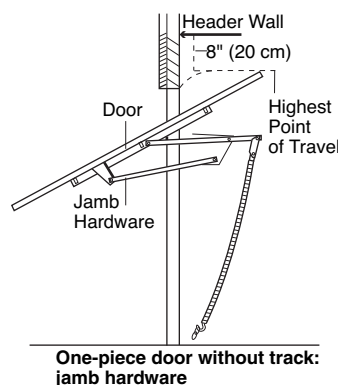
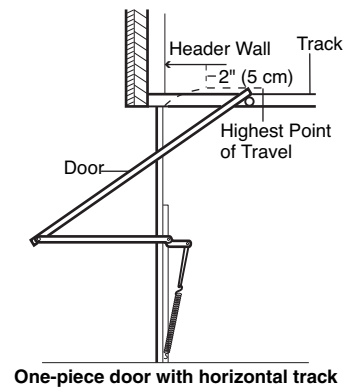
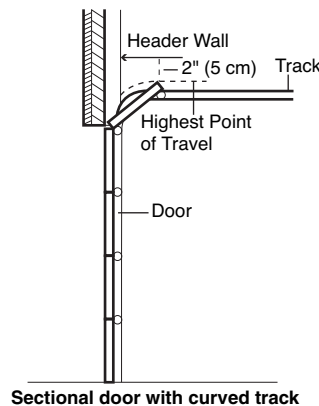
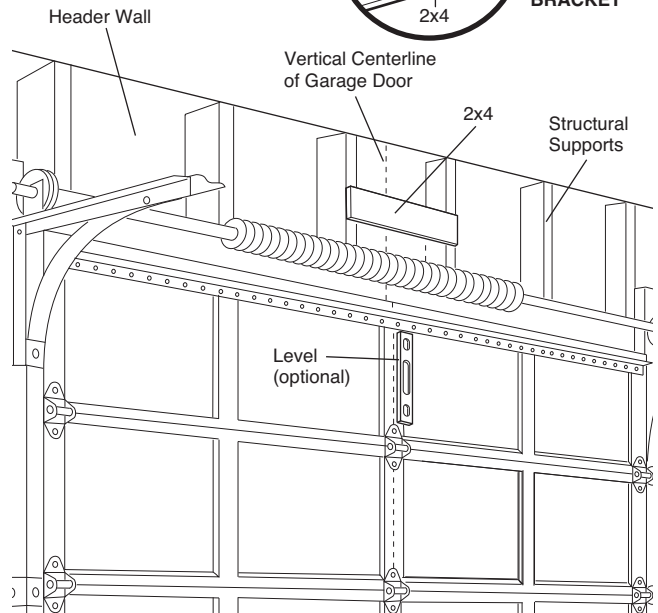
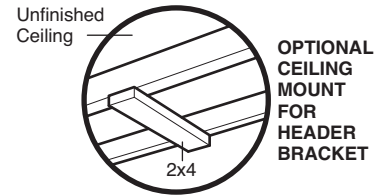

INSTALLATION STEP 2

Install the Header Bracket

You can attach the header bracket either to the wall above the garage door, or to the ceiling. Follow the instructions which will work best for your particular requirements. **Do not install the header bracket over drywall. If installing into masonry, use concrete anchors (not provided).**

WALL HEADER BRACKET INSTALLATION

- Center the bracket on the vertical centerline with the bottom edge of the bracket on the horizontal line as shown (with the arrow pointing toward the ceiling).
- Mark the vertical set of bracket holes (do not use the holes designated for ceiling mount). Drill 3/16" pilot holes and fasten the bracket securely to a structural support with the hardware provided.

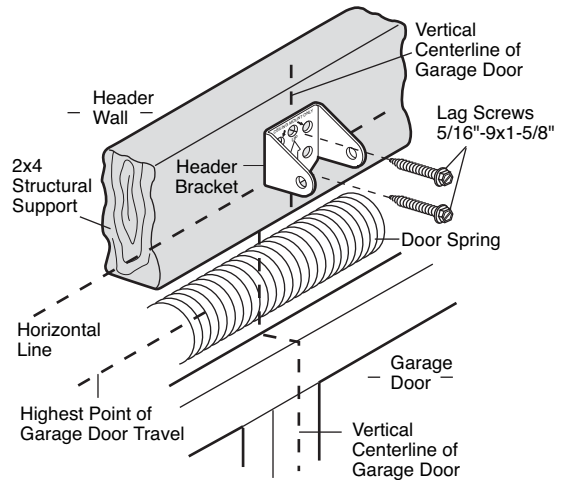
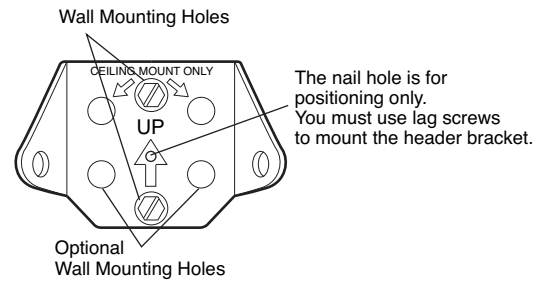
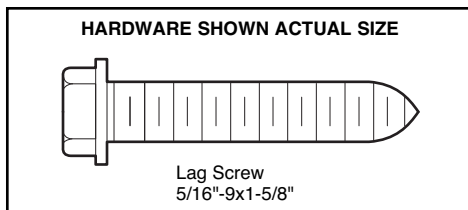

CEILING HEADER BRACKET INSTALLATION

- Extend the vertical centerline onto the ceiling as shown.
- Center the bracket on the vertical mark, no more than 6" (15 cm) from the wall. Make sure the arrow is pointing toward the wall. The bracket can be mounted flush against the ceiling when clearance is minimal.
- Mark the side holes. Drill 3/16" pilot holes and fasten bracket securely to a structural support with the hardware provided.

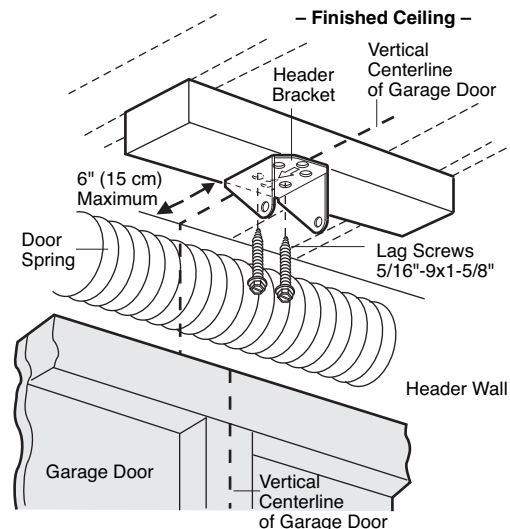
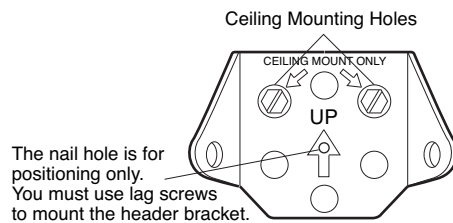

INSTALLATION STEP 3

Attach the Rail to the Header Bracket

- Position the opener on the garage floor below the header bracket. Use packing material as a protective base. **NOTE: If the door spring is in the way you'll need help. Have someone hold the opener securely on a temporary support to allow the rail to clear the spring.**
- Position the rail bracket against the header bracket.
- Align the bracket holes and join with a clevis pin as shown.
- Insert a ring fastener to secure.

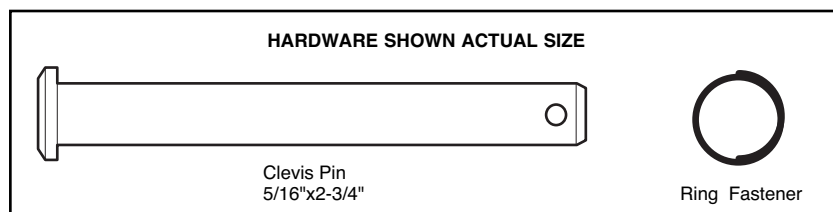
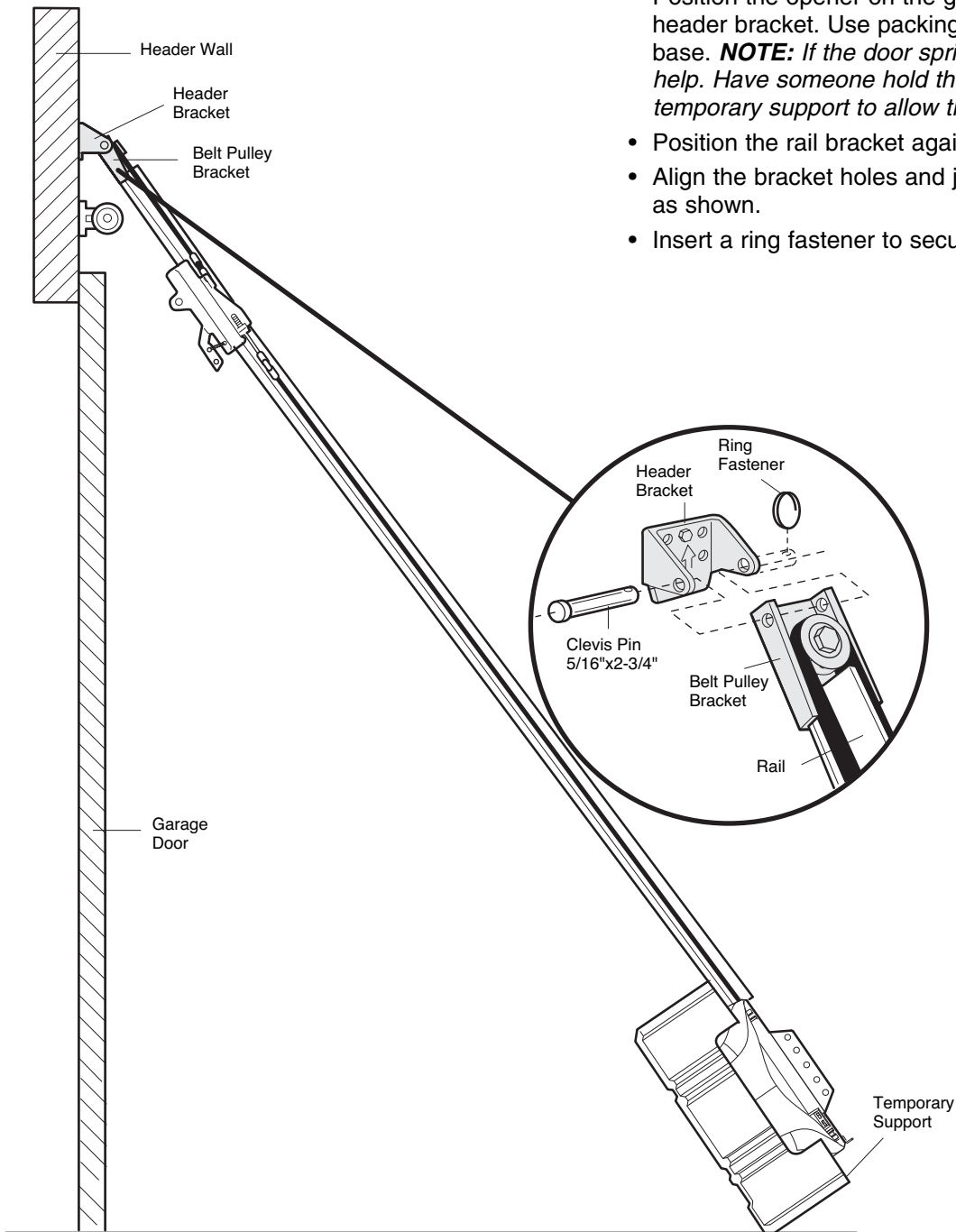

INSTALLATION STEP 4

Position the Opener

Follow instructions which apply to your door type as illustrated.

SECTIONAL DOOR OR ONE-PIECE DOOR WITH TRACK

A 2x4 laid flat is convenient for setting an ideal door-to-rail distance.

- Raise the opener onto a stepladder. You will need help at this point if the ladder is not tall enough.
- Open the door all the way and place a 2x4 laid flat on the top section beneath the rail.
- If the top section or panel hits the trolley when you raise the door, pull down on the trolley release arm to disconnect inner and outer sections. Slide the outer trolley toward the motor unit. The trolley can remain disconnected until Installation Step 12 is completed.

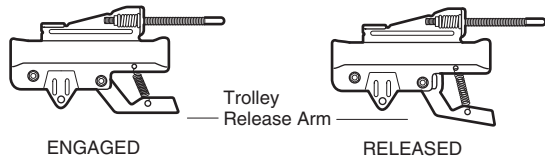

ONE-PIECE DOOR WITHOUT TRACK

- With the door fully open and parallel to the floor, measure the distance from the floor to the top of the door.
- Using a stepladder as a support, raise the top of the opener to this height.
- The top of the door should be level with the top of the motor unit. Do not position the opener more than 4" (10 cm) above this point.

CAUTION

To prevent damage to garage door, rest garage door opener rail on 2x4 placed on top section of door.

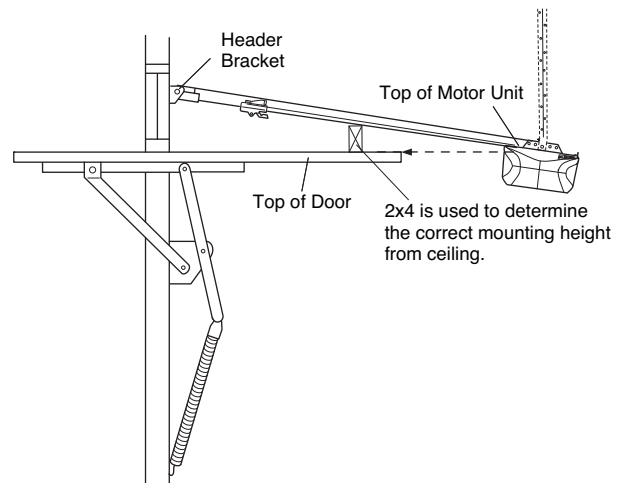
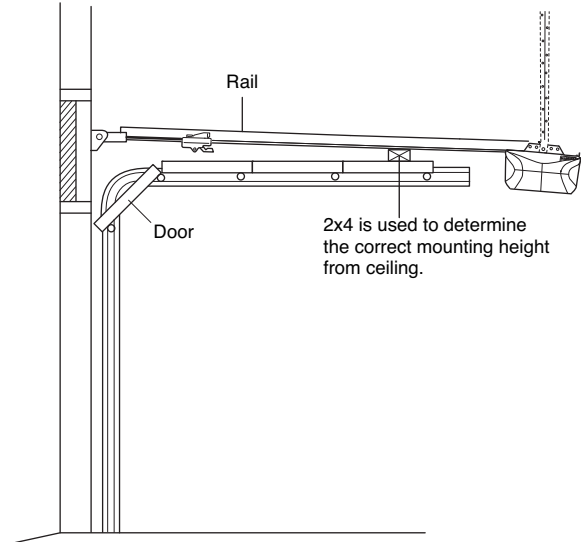

INSTALLATION STEP 5

Hang the Opener

Three representative installations are shown. Yours may be different. Hanging brackets should be angled (Figure 1) to provide rigid support. On finished ceilings (Figure 2 and Figure 3), attach a sturdy metal bracket to structural supports before installing the opener. This bracket and fastening hardware are not provided.

1. Remove foam packaging. Measure the distance from each side of the motor unit to the structural support.
2. Cut both pieces of the hanging bracket to required lengths.
3. Drill 3/16" pilot holes in the structural supports.
4. Attach one end of each bracket to a support with 5/16"-18x1-7/8" lag screws.
5. Fasten the opener to the hanging brackets with 5/16"-18x7/8" hex bolts, lock washers and nuts.
6. Check to make sure the rail is centered over the door (or in line with the header bracket if the bracket is not centered above the door).
7. Remove the 2x4. Operate the door manually. If the door hits the rail, raise the header bracket.
8. Grease the top and underside of the rail surface where the trolley slides with rail grease.

NOTE: DO NOT connect power to opener at this time.

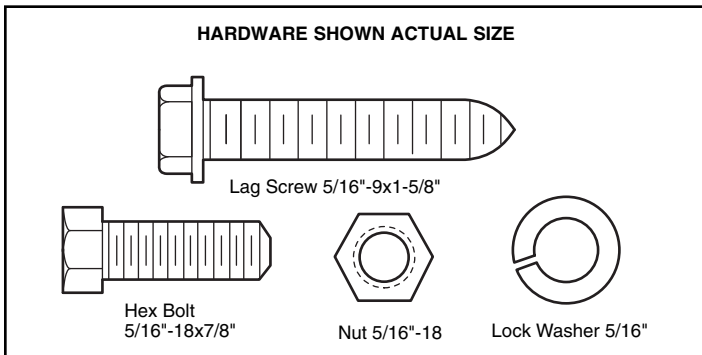

⚠ WARNING

To avoid possible **SERIOUS INJURY** from a falling garage door opener, fasten it **SECURELY** to structural supports of the garage. Concrete anchors **MUST** be used if installing **ANY** brackets into masonry.

Figure 1

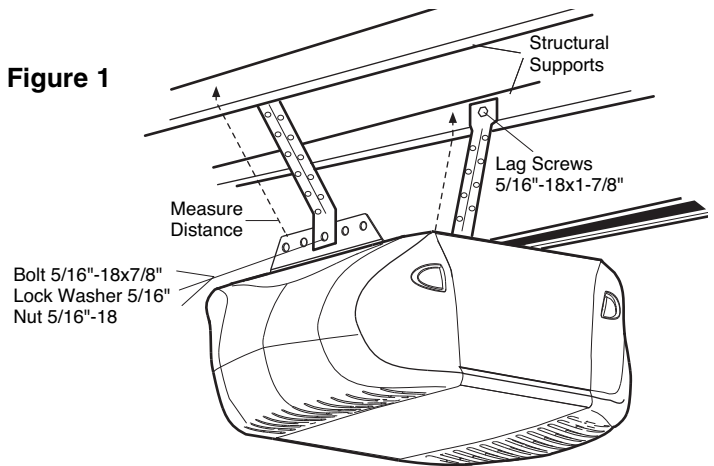

Figure 2

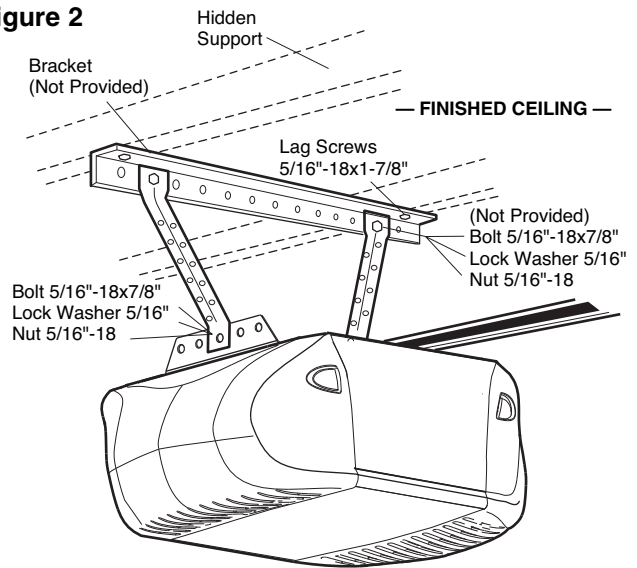
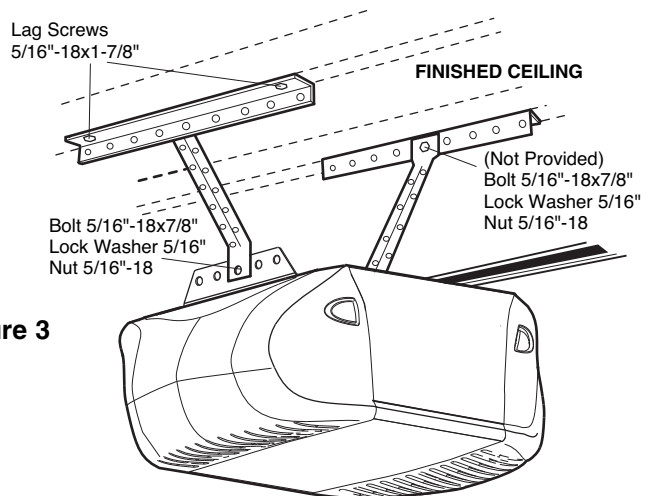

Figure 3



INSTALLATION STEP 6

Install the Smart Control Panel™

Locate door control within sight of door, at a minimum height of 5' (1.5 m) where small children cannot reach, away from moving parts of door and door hardware. If installing into drywall, drill 5/32" holes and use the anchors provided. For pre-wired installations (as in new home construction), it may be mounted to a single gang box (Figure 1).

NOTE: The functional temperature range of the door control is between -4° F (-20° C) and 122° F (50° C). Scroll speed of display is slower at lower temperatures although the door control remains fully functional.

CAUTION: Continuous exposure of the door control to temperatures below -22° F (-30° C) may damage the LCD screen.

SPECIAL NOTE: Only one 398LM can be connected to each garage door opener. If additional wall controls are desired to operate the same garage door opener, it is recommended to use model 378LM wireless wall control as the secondary door control.

- Strip 7/16" (11 mm) of insulation from one end of bell wire and connect to the two screw terminals on back of door control by color: white wire to the W (2) and white/red wire to the R (1) (Figure 2).
- Remove push bar cover by gently prying at the lower/middle portion of the cover with a small flat-head screwdriver (Figure 1). Fasten with 6AB x 1-1/4" self-tapping screws (drywall installation) or 6-32 x 1" machine screws (into gang box) as follows:
 - Install bottom screw, allowing 1/8" (3 mm) to protrude above wall surface.
 - Position bottom of door control on screw head and slide down to secure. Adjust screw for snug fit.
 - Drill and install top screw with care to avoid cracking plastic housing. **Do NOT overtighten.**
 - Replace cover by inserting top tabs first and then snap cover in place (figure 1).
- (For standard installations ONLY)** Run bell wire up wall and across ceiling to motor unit. Use insulated staples to secure wire in several places. Do NOT pierce wire with a staple, creating a short or open circuit.
- Strip 7/16" (11 mm) of insulation from end of bell wire. Connect bell wire to the quick-connect terminals on the motor unit: white to white and white/red to red (Figure 2).

NOTE: If you have any trouble with the operation of the buttons, loosen the top mounting screw. **DO NOT** connect power and operate the opener at this time. The trolley will travel to the full open position but will not return to the close position until the sensor beam is connected and properly aligned.

⚠️ WARNING

To prevent possible SERIOUS INJURY or DEATH from electrocution:

- Be sure power is not connected BEFORE installing door control.
- Connect ONLY to 24 VOLT low voltage wires.

To prevent possible SERIOUS INJURY or DEATH from a closing garage door:

- Install door control within sight of garage door, out of reach of children at a minimum height of 5 feet (1.5 m) and away from ALL moving parts of door.
- NEVER permit children to operate or play with door control push buttons or remote control transmitters.
- Activate door ONLY when it can be seen clearly, is properly adjusted and there are no obstructions to door travel.
- ALWAYS keep garage door in sight until completely closed. NEVER permit anyone to cross path of closing garage door.

HARDWARE SHOWN ACTUAL SIZE

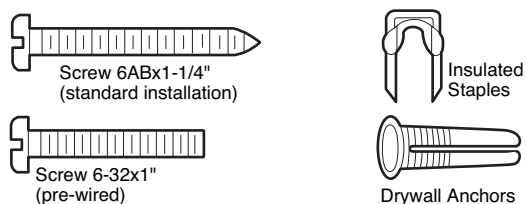

Figure 1

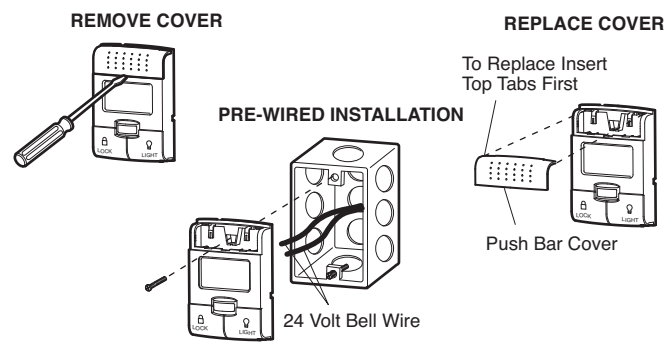
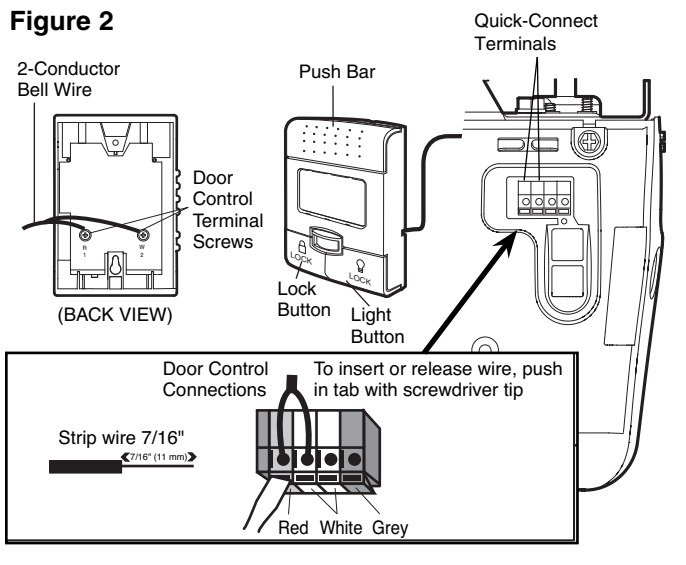

Figure 2



INSTALLATION STEP 7

Install the Standby Power (Optional)

- Make sure motor unit is unplugged.
- Using a Phillips head screwdriver, remove the battery cover on the motor unit.
- Partially insert battery into motor unit with terminals facing out.
- Connect red (+) and black (-) wires from motor unit to corresponding terminals on battery.
- Replace battery cover.

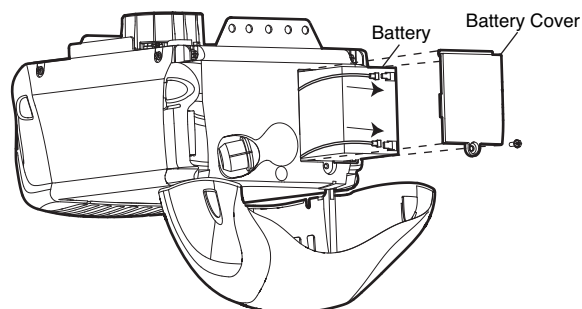

INSTALLATION STEP 8

Install the Lights

- Press the release tabs on both sides of lens. Gently rotate lens back and downward until the lens hinge is in the fully open position. Do not remove the lens.
- Install a 100 watt maximum light bulb in each socket. Light bulb size should be A19, standard neck only. The lights will turn ON and remain lit for approximately 4-1/2 minutes when power is connected. Then the lights will turn OFF.
- Reverse the procedure to close the lens.
- Use A19, standard neck garage door opener bulbs for replacement.

NOTE: Use only standard light bulbs. The use of short neck or specialty light bulbs may overheat the endpanel or light socket.

CAUTION

To prevent possible OVERHEATING of the endpanel or light socket:

- DO NOT use short neck or specialty light bulbs.
- DO NOT use halogen bulbs. Use ONLY incandescent.

To prevent damage to the opener:

- DO NOT use bulbs larger than 100W.
- ONLY use A19 size bulbs.

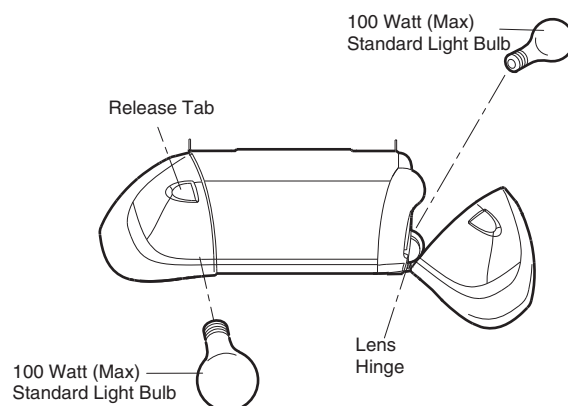

INSTALLATION STEP 9

Attach the Emergency Release Rope and Handle

- Thread one end of the rope through the hole in the top of the red handle so “NOTICE” reads right side up as shown. Secure with an overhand knot at least 1" (2.5 cm) from the end of the rope to prevent slipping.
- Thread the other end of the rope through the hole in the release arm of the outer trolley.
- Adjust rope length so the handle is 6' (1.8 m) above the floor. Ensure that the rope and handle clear the tops of all vehicles to avoid entanglement. Secure with an overhand knot.

NOTE: If it is necessary to cut the rope, heat seal the cut end with a match or lighter to prevent unraveling.

⚠ WARNING

To prevent possible **SERIOUS INJURY** or **DEATH** from a falling garage door:

- If possible, use emergency release handle to disengage trolley **ONLY** when garage door is **CLOSED**. Weak or broken springs or unbalanced door could result in an open door falling rapidly and/or unexpectedly.
- **NEVER** use emergency release handle unless garage doorway is clear of persons and obstructions.
- **NEVER** use handle to pull door open or closed. If rope knot becomes untied, you could fall.

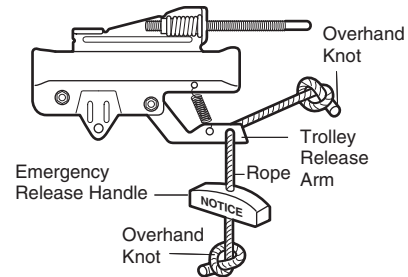

INSTALLATION STEP 10

Electrical Requirements

To avoid installation difficulties, do not run the opener at this time.

To reduce the risk of electric shock, your garage door opener has a grounding type plug with a third grounding pin. This plug will only fit into a grounding type outlet. If the plug doesn't fit into the outlet you have, contact a qualified electrician to install the proper outlet.

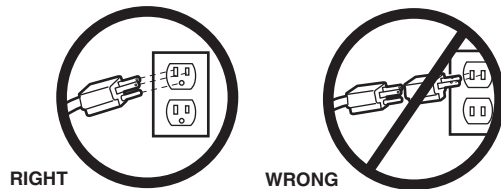

If permanent wiring is required by your local code, refer to the following procedure.

To make a permanent connection through the 7/8" (2 cm) hole in the top of the motor unit:

- Remove the motor unit cover screws and set the cover aside.
- Remove the attached 3-prong cord.
- Connect the black (line) wire to the screw on the brass terminal; the white (neutral) wire to the screw on the silver terminal; and the ground wire to the green ground screw. **The opener must be grounded.**
- Reinstall the cover.

To avoid installation difficulties, do not run the opener at this time.

⚡ WARNING

To prevent possible **SERIOUS INJURY** or **DEATH** from electrocution or fire:

- Disconnect **ALL** electric and battery power **BEFORE** performing **ANY** service or maintenance.
- Garage door installation and wiring **MUST** be in compliance with **ALL** local electrical and building codes.
- **NEVER** use an extension cord, 2-wire adapter, or change plug in **ANY** way to make it fit outlet. Be sure the opener is grounded.

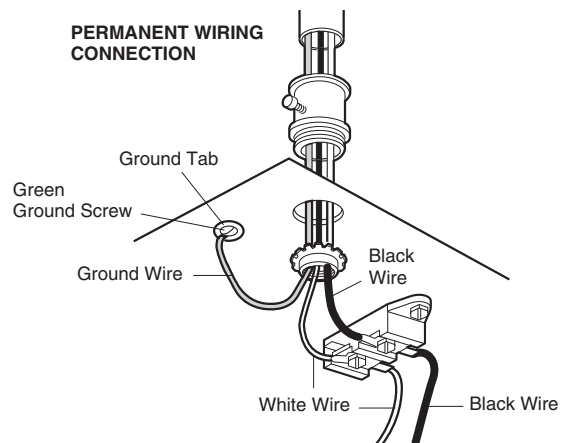

INSTALLATION STEP 11

Install The Protector System®

The safety reversing sensor must be connected and aligned correctly before the garage door opener will move in the down direction.

IMPORTANT INFORMATION ABOUT THE SAFETY REVERSING SENSOR

When properly connected and aligned, the sensor will detect an obstacle in the path of its electronic beam. The sending eye (with an amber indicator light) transmits an invisible light beam to the receiving eye (with a green indicator light). If an obstruction breaks the light beam while the door is closing, the door will stop and reverse to full open position, and the opener lights will flash 10 times.

The units must be installed inside the garage so that the sending and receiving eyes face each other across the door, no more than 6" (15 cm) above the floor. Either can be installed on the left or right of the door as long as the sun never shines directly into the receiving eye lens.

The mounting brackets are designed to clip onto the track of sectional garage doors without additional hardware.

⚠ WARNING

Be sure power is NOT connected to the garage door opener BEFORE installing the safety reversing sensor.

To prevent SERIOUS INJURY or DEATH from a closing garage door:

- Correctly connect and align the safety reversing sensor. This required safety device MUST NOT be disabled.
- Install the safety reversing sensor so beam is NO HIGHER than 6" (15 cm) above garage floor.

If it is necessary to mount the units on the wall, the brackets must be securely fastened to a solid surface such as the wall framing. Extension brackets (see Accessories) are available if needed. If installing in masonry construction, add a piece of wood at each location to avoid drilling extra holes in masonry if repositioning is necessary.

The invisible light beam path must be unobstructed. No part of the garage door (or door tracks, springs, hinges, rollers or other hardware) may interrupt the beam while the door is closing.

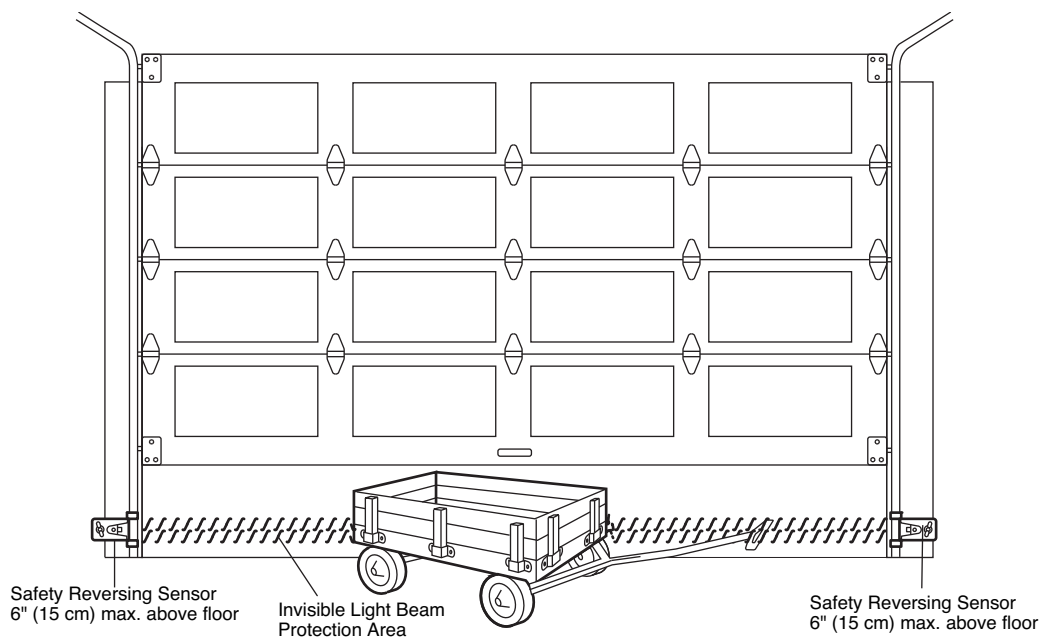

Facing the door from inside the garage

INSTALLING THE BRACKETS

Be sure power to the opener is disconnected. Install and align the brackets so the sensors will face each other across the garage door, with the beam no higher than 6" (15 cm) above the floor. They may be installed in one of three ways, as follows.

Garage door track installation (preferred):

- Slip the curved arms over the rounded edge of each door track, with the curved arms facing the door. Snap into place against the side of the track. It should lie flush, with the lip hugging the back edge of the track (Figure 1).

If your door track will not support the bracket securely, wall installation is recommended.

Wall installation (Figure 2 & 3):

- Place the bracket against the wall with curved arms facing the door. Be sure there is enough clearance for the sensor beam to be unobstructed.
- If additional depth is needed, an extension bracket (see Accessories) or wood blocks can be used.
- Use bracket mounting holes as a template to locate and drill (2) 3/16" diameter pilot holes on the wall at each side of the door, no higher than 6" (15 cm) above the floor.
- Attach brackets to wall with lag screws (not provided).
- If using extension brackets or wood blocks, adjust right and left assemblies to the same distance out from the mounting surface. Make sure all door hardware obstructions are cleared.

Floor installation (Figure 4):

- Use wood blocks or extension brackets (see Accessories) to elevate sensor brackets so the lenses will be no higher than 6" (15 cm) above the floor.
- Carefully measure and place right and left assemblies at the same distance out from the wall. Be sure all door hardware obstructions are cleared.
- Fasten to the floor with concrete anchors as shown.

Figure 1 DOOR TRACK MOUNT (RIGHT SIDE)

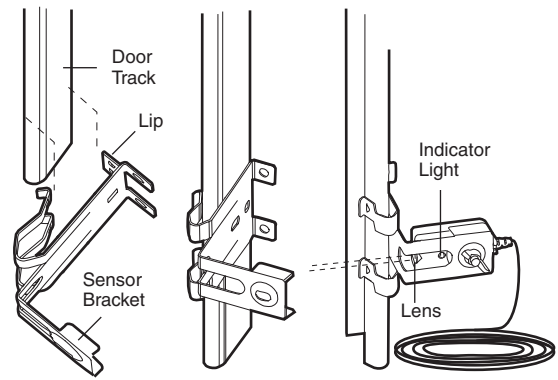

Figure 2 WALL MOUNT (RIGHT SIDE)

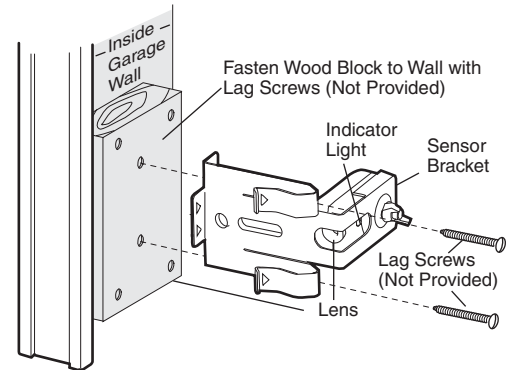

Figure 3 WALL MOUNT (RIGHT SIDE)

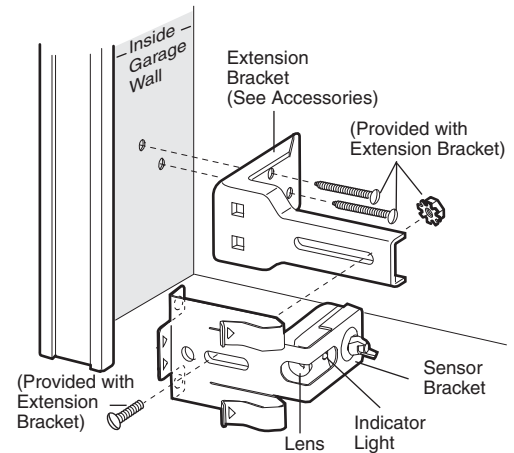
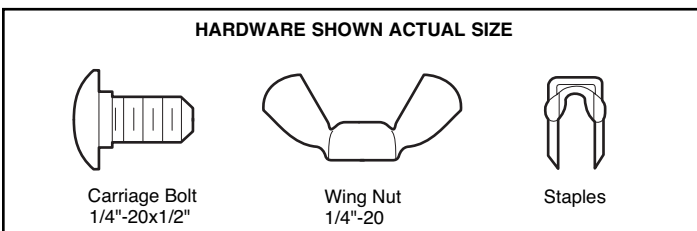
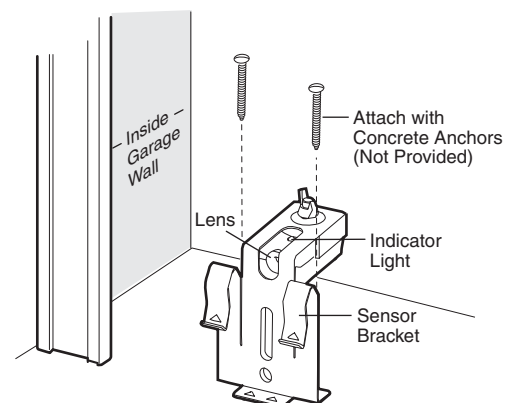

Figure 4 FLOOR MOUNT (RIGHT SIDE)



MOUNTING AND WIRING THE SAFETY REVERSING SENSORS

- Slide a 1/4"-20x1/2" carriage bolt head into the slot on each sensor. Use wing nuts to fasten sensors to brackets, with lenses pointing toward each other across the door. Be sure the lens is not obstructed by a bracket extension (Figure 5).
- Finger tighten the wing nuts.
- Run the wires from both sensors to the opener. Use insulated staples to secure wire to wall and ceiling.
- Strip 7/16" (11 mm) of insulation from each set of wires. Separate white and white/black wires sufficiently to connect to the opener quick-connect terminals. Twist like colored wires together. Insert wires into quick-connect holes: white to white and white/black to grey (Figure 6).

ALIGNING THE SAFETY REVERSING SENSORS

- Plug in the opener. The indicator lights in both the *sending* and *receiving eyes* will *glow steadily* if wiring connections and alignment are correct.

The *sending* eye amber indicator light will glow regardless of alignment or obstruction. If the green indicator light in the *receiving eye* is off, dim, or flickering (and the invisible light beam path is not obstructed), alignment is required.

- Loosen the *sending* eye wing nut and readjust, aiming directly at the receiving eye. Lock in place.
- Loosen the *receiving* eye wing nut and adjust sensor until it receives the sender's beam. When the green indicator light *glows steadily*, tighten the wing nut.

Figure 5

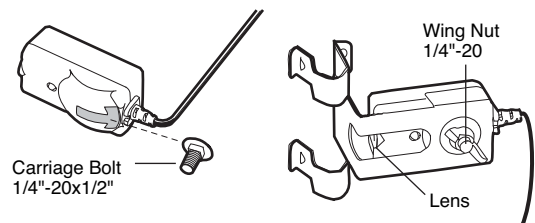

TROUBLESHOOTING THE SAFETY REVERSING SENSORS

1. If the *sending* eye indicator light does not *glow steadily* after installation, check for:
 - Electric power to the opener.
 - A short in the white or white/black wires. These can occur at staples, or at opener connections.
 - Incorrect wiring between sensors and opener.
 - A broken wire.
2. If the *sending* eye indicator light *glows* steadily but the *receiving* eye indicator light doesn't:
 - Check alignment.
 - Check for an open wire to the receiving eye.
3. If the *receiving* eye indicator light is dim, realign either sensor.

NOTE: When the invisible beam path is obstructed or misaligned while the door is closing, the door will reverse. If the door is already open, it will not close. The opener lights will blink 10 times. See page 16.

Figure 6

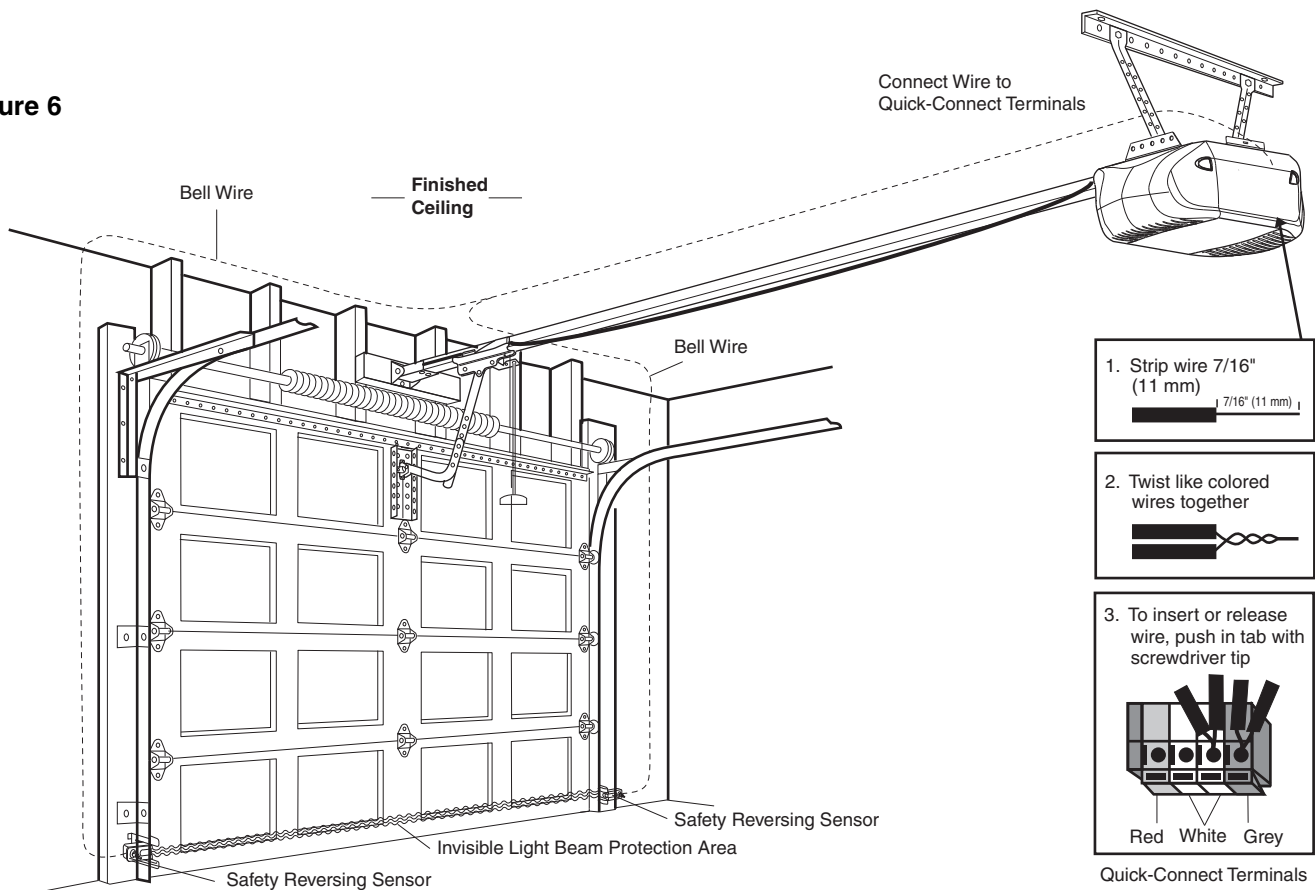

INSTALLATION STEP 12

Fasten the Door Bracket

Follow instructions which apply to your door type as illustrated below or on the following page.

A horizontal reinforcement brace should be long enough to be secured to two or three vertical supports. A vertical reinforcement brace should cover the height of the top panel.

Figure 1 shows one piece of angle iron as the horizontal brace. For the vertical brace, 2 pieces of angle iron are used to create a U-shaped support. The best solution is to check with your garage door manufacturer for an opener installation door reinforcement kit.

NOTE: Many door reinforcement kits provide for direct attachment of the clevis pin and door arm. In this case you will not need the door bracket; proceed to Step 13.

SECTIONAL DOORS

1. Center the door bracket on the previously marked vertical centerline used for the header bracket installation. Note correct UP placement, as stamped inside the bracket.
2. Position the top edge of the bracket 2"-4" (5-10 cm) below the top edge of the door, OR directly below any structural support across the top of the door.
3. Mark, drill holes and install as follows, depending on your door's construction:

Metal or light weight doors using a vertical angle iron brace between the door panel support and the door bracket:

- Drill 3/16" fastening holes. Secure the door bracket using the two 1/4"-14x5/8" self-threading screws (Figure 2A).
- Alternately, use two 5/16" bolts, lock washers and nuts (not provided) (Figure 2B).

Metal, insulated or light weight factory reinforced doors:

- Drill 3/16" fastening holes. Secure the door bracket using the self-threading screws (Figure 3).

Wood Doors:

- Use top and bottom or side to side door bracket holes. Drill 5/16" holes through the door and secure bracket with 5/16"x2" carriage bolts, lock washers and nuts (not provided) (Figure 4).

NOTE: The 1/4"-14x5/8" self-threading screws are not intended for use on wood doors.



CAUTION

Fiberglass, aluminum or lightweight steel garage doors **WILL REQUIRE** reinforcement BEFORE installation of door bracket. Contact your door manufacturer for reinforcement kit.

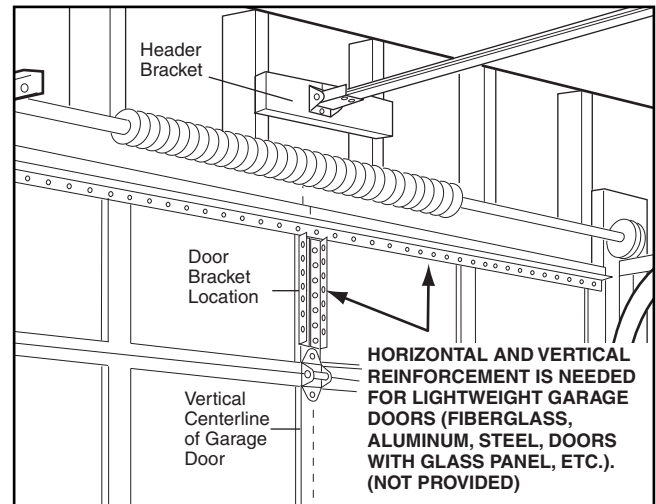

Figure 1

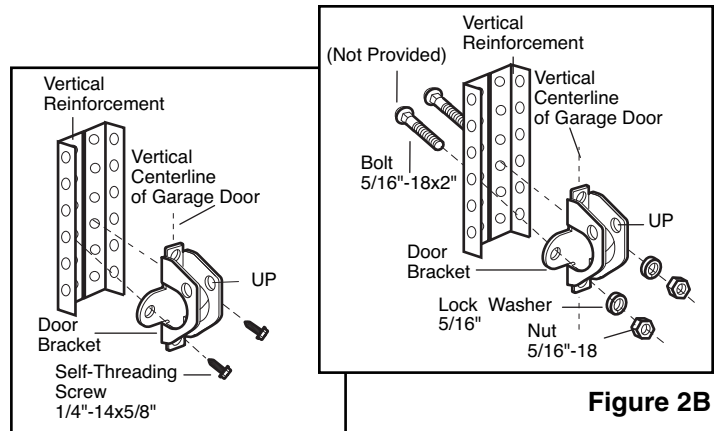

Figure 2A

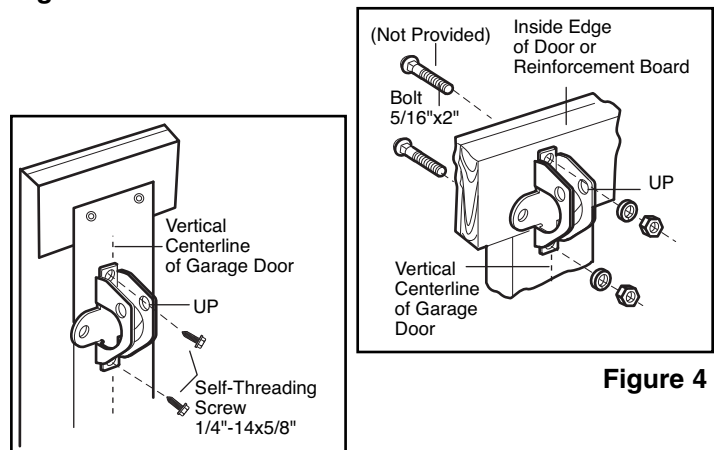

Figure 3

Figure 4

ONE-PIECE DOORS

Please read and comply with the warnings and reinforcement instructions on the previous page. They apply to one-piece doors also.

- Center the door bracket on the top of the door, in line with the header bracket as shown. Mark either the left and right, or the top and bottom holes.
- **Metal Doors:** Drill 3/16" pilot holes and fasten the bracket with the 1/4"-14x5/8" self-threading screws provided.
- **Wood Doors:** Drill 5/16" holes and use 5/16"x2" carriage bolts, lock washers and nuts (not provided) or 5/16"x1-1/2" lag screws (not provided) depending on your installation needs.

NOTE: The door bracket may be installed on the top edge of the door if required for your installation. (Refer to the dotted line optional placement drawing.)

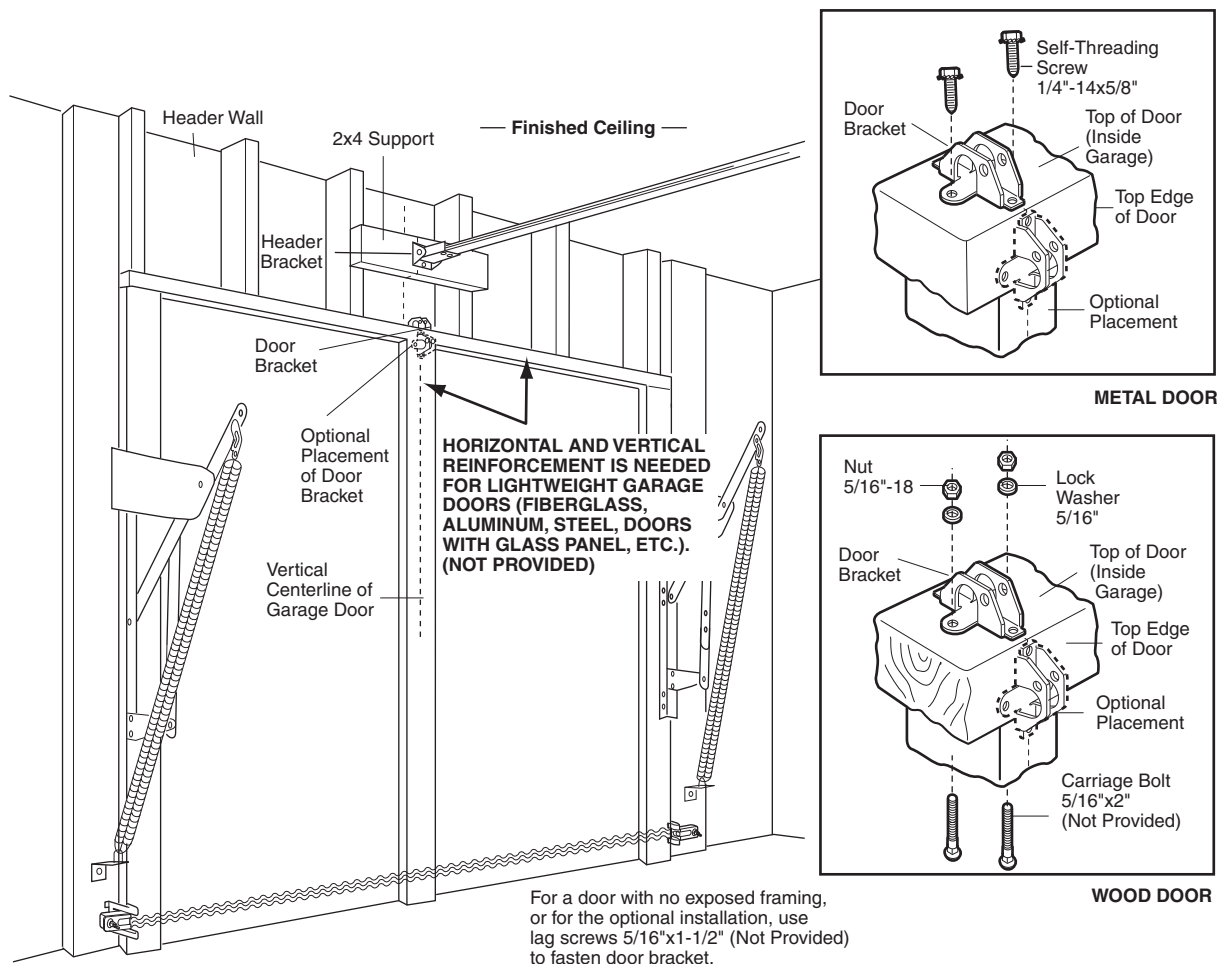
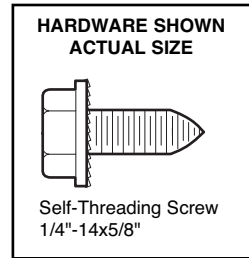

INSTALLATION STEP 13

Connect Door Arm to Trolley

Follow instructions which apply to your door type as illustrated below and on the following page.

SECTIONAL DOORS ONLY

Make sure garage door is fully closed. Pull the emergency release handle to disconnect the outer trolley from the inner trolley. Slide the outer trolley back (away from the door) about 2" (5 cm) (Figures 1, 2 and 3).

Figure 1:

- Fasten straight door arm section to outer trolley with the 5/16"x1" clevis pin. Secure the connection with a ring fastener.
- Fasten curved section to the door bracket in the same way, using the 5/16"x1-1/4" clevis pin.

Figure 2:

- Bring arm sections together. Find two pairs of holes that line up and join sections. Select holes as far apart as possible to increase door arm rigidity.

Figure 3, Hole alignment alternative:

- If holes in curved arm are above holes in straight arm, disconnect straight arm. Cut about 6" (15 cm) from the solid end. Reconnect to trolley with cut end down as shown.
- Bring arm sections together.
- Find two pairs of holes that line up and join with bolts, lock washers and nuts.

Pull the emergency release handle toward the opener at a 45° angle so that the trolley release arm is horizontal. Proceed to Adjustment Step 1, page 23. Trolley will re-engage automatically when opener is operated.

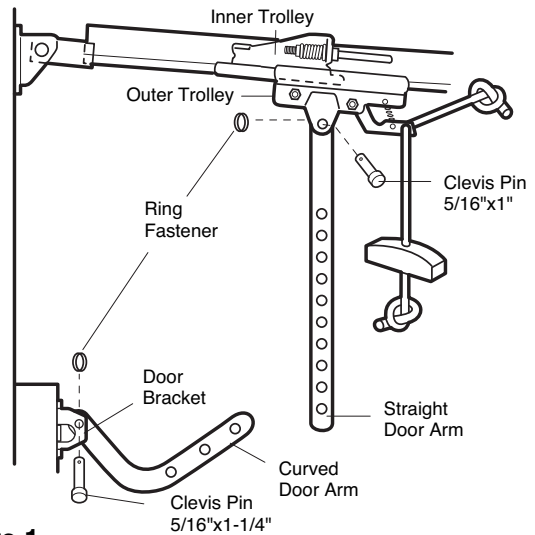

Figure 1

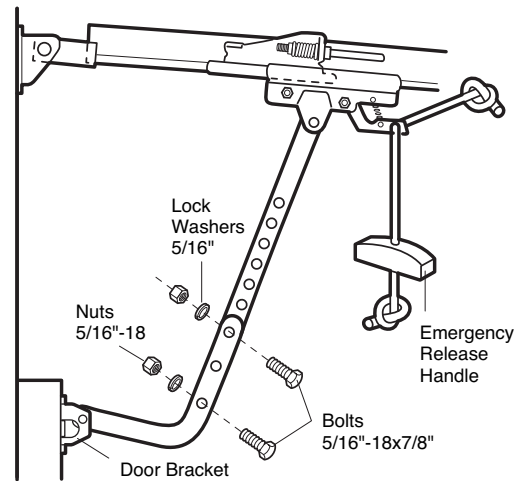

Figure 2

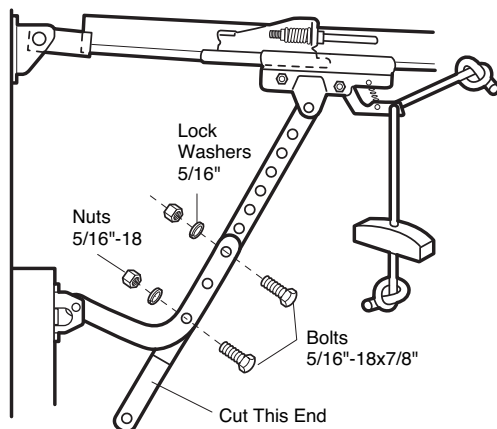
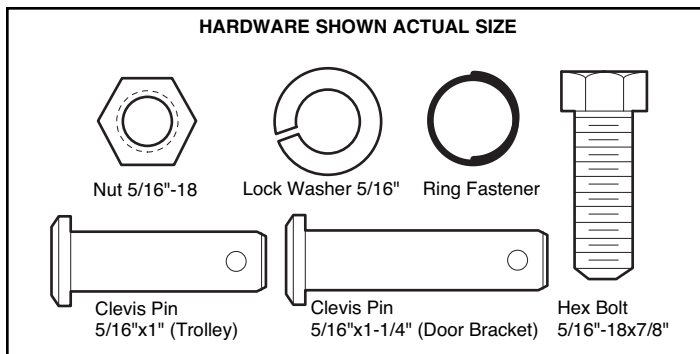

Figure 3



ALL ONE-PIECE DOORS

1. Assemble the Door Arm:

- Fasten the straight and curved door arm sections together to the longest possible length (with a 2 or 3 hole overlap).
- Make sure the garage door is fully closed. Connect the straight door arm section to the door bracket with the 5/16"x1-1/4" clevis pin.
- Secure with a ring fastener.
- Pull the emergency release handle, disconnecting the outer trolley from the inner trolley by pulling straight down on the emergency release handle and sliding the outer trolley back toward the motor unit.
- Connect the curved door arm section to the trolley using the 5/16"x1-1/4" clevis pin and ring fastener.

NOTE: Adjusting the limits on the following page:

- The trolley will automatically connect. If not, review the trolley lockout feature on page 27.
- When setting the up limit on the following page, the door should not have a "backward" slant when fully open as illustrated below. A slight backward slant will cause unnecessary bucking and/or jerking operation as the door is being opened or closed from the fully open position.

Figure 4

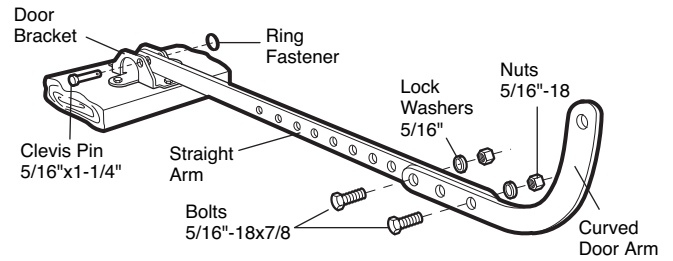
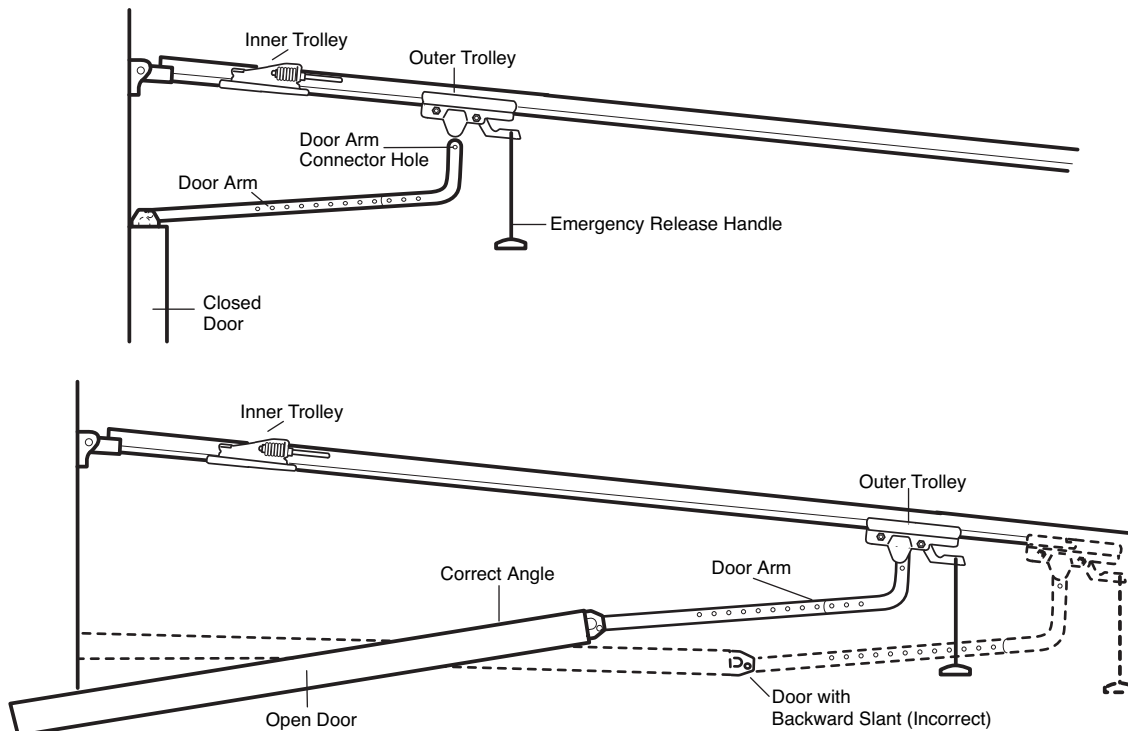

Figure 5



ADJUSTMENT STEP 1

Program the Travel Limits

Travel limits regulate the points at which the door will stop when moving up or down. Follow the steps below to set the limits.

To program the travel limits:

Figure 1

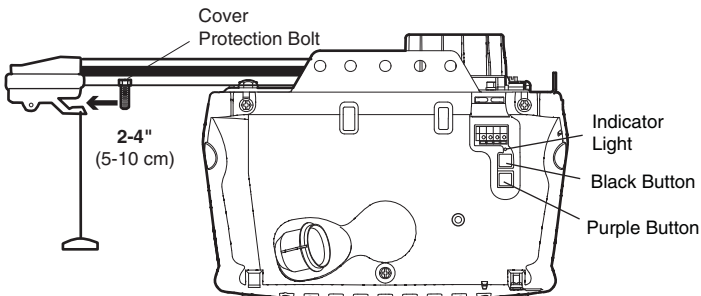

Adjust the position of the door by using the black and purple buttons. Black moves the door UP (open) and purple moves the door DOWN (close).

- Setting the UP position:** Press and hold the black button until the yellow indicator light starts flashing slowly then release.
 - Push and hold the black button until the door reaches the desired UP (open) position (Figure 2).
- NOTE:** Check to be sure the door opens high enough for your vehicle.
- Push the remote control or door control (Figure 3). This sets the UP (open) limit and begins closing the door.
 - Immediately when the door begins to move down, press and release either the black or purple button. This will stop the door.
 - Setting the DOWN position:** Push and hold the purple button until the door reaches the desired DOWN (closed) position (Figure 4).
 - Once the door is closed, if there appears to have too much pressure on the door, you may toggle the door back and forth using the black and purple buttons to reach the desired closed position.
 - Push the remote control or the door control (Figure 3). This sets the DOWN (close) limit and should bring the door to the open position.

- If the opener is not stopping exactly where you would like it, repeat steps 1 through 7 and program the limits again.
- When the unit stops in both the desired up (open) and down (close) positions, proceed to *Adjustment Steps 2, Setting the Force*.

WARNING

Without a properly installed safety reversal system, persons (particularly small children) could be SERIOUSLY INJURED or KILLED by a closing garage door.

- Incorrect adjustment of garage door travel limits will interfere with proper operation of safety reversal system.
- NEVER use force adjustments to compensate for a binding or sticking garage door.
- After ANY adjustments are made, the safety reversal system MUST be tested. Door MUST reverse on contact with 1-1/2" (3.8 cm) high object (or 2x4 laid flat) on floor.

CAUTION

To prevent damage to vehicles, be sure fully open door provides adequate clearance.

Figure 2

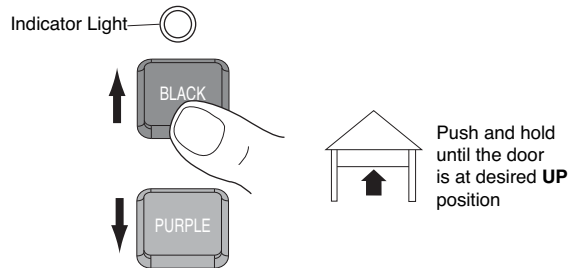

Figure 3

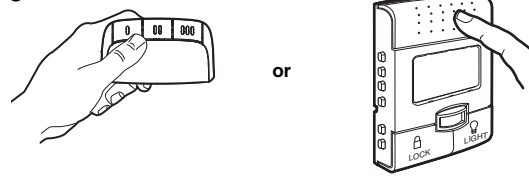
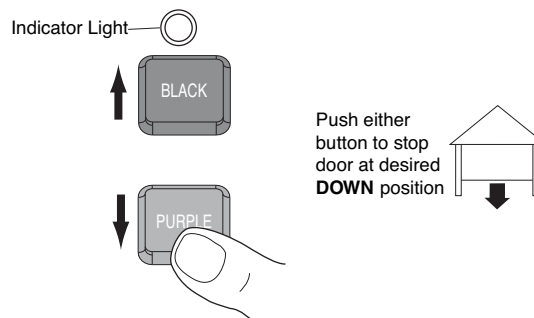

Figure 4



ADJUSTMENT STEP 2

Setting the Force

The force setting button is located on the left panel of the motor unit. The force setting measures the amount of force required to open and close the door.

1. Locate the purple button on the left panel of the motor unit (Figure 1).
2. Push the purple button twice to enter the opener into Force Adjustment Mode (Figure 2). The LED (Indicator Light) will flash quickly.
3. Push the remote control or door control (Figure 3). The door will travel to the DOWN (close) position. Push the remote control or door control again, the door will travel to the UP (open) position. Push the remote control or door control a third time to send the door to the DOWN (close) position.

The LED (Indicator Light) will stop flashing when the force has been learned.

The opener has learned the forces required to open and close your door.

The door must travel through a complete cycle, UP and DOWN, in order for the force to be set properly. If the opener cannot open and close your door fully, inspect your door to insure that it is balanced properly and is not sticking or binding. See page 3, "Preparing your garage door."

! WARNING

Without a properly installed safety reversal system, persons (particularly small children) could be SERIOUSLY INJURED or KILLED by a closing garage door.

- Too much force on garage door will interfere with proper operation of safety reversal system.
- NEVER use force adjustments to compensate for a binding or sticking garage door.
- After ANY adjustments are made, the safety reversal system MUST be tested. Door MUST reverse on contact with 1-1/2" (3.8 cm) high object (or 2x4 laid flat) on floor.

Figure 1

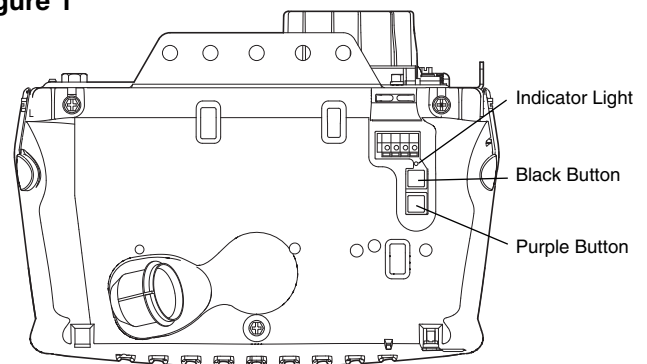

Figure 2

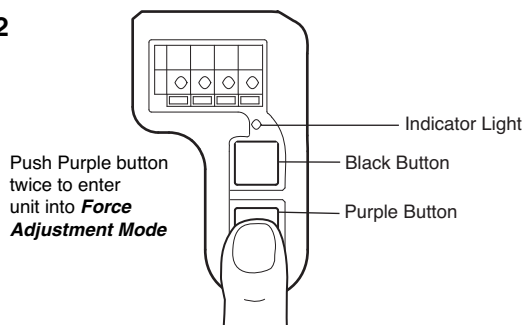
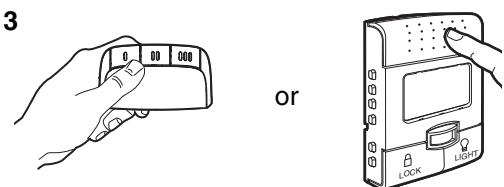

Figure 3



ADJUSTMENT STEP 3

Test the Safety Reversal System

TEST

- With the door fully open, place a 1-1/2" (3.8 cm) board (or a 2x4 laid flat) on the floor, centered under the garage door.
- Operate the door in the down direction. The door **must** reverse on striking the obstruction.

ADJUST

- If the door stops on the obstruction, it is not traveling far enough in the down direction. Complete Adjustment Steps 1 and 2 Programming the Limits and Forces.

NOTE: On a sectional door, make sure limit adjustments do not force the door arm beyond a straight up and down position. See Figure 3, page 21.

- Repeat the test.
- When the door reverses on the 1-1/2" (3.8 cm) board (or 2x4 laid flat), remove the obstruction and run the opener through 3 or 4 complete travel cycles to test adjustment.
- If the unit continues to fail the Safety Reverse Test, call for a trained door systems technician.

IMPORTANT SAFETY CHECK:

Test the Safety Reverse System after:

- Each adjustment of door arm length, limits, or force controls.
- Any repair to or adjustment of the garage door (including springs and hardware).
- Any repair to or buckling of the garage floor.
- Any repair to or adjustment of the opener.

ADJUSTMENT STEP 4

Test The Protector System® (Safety Sensors)

- Press the remote control push button to open the door.
- Place the opener carton in the path of the door.
- Press the remote control push button to close the door. The door will not move more than 1" (2.5 cm), and the opener lights will flash.

The garage door opener will not close from a remote if the indicator light in either sensor is off (alerting you to the fact that the sensor is misaligned or obstructed).

If the opener closes the door when the safety reversing sensor is obstructed (and the sensors are no more than 6" (15 cm) above the floor), call for a trained door systems technician.

⚠ WARNING

Without a properly installed safety reversal system, persons (particularly small children) could be **SERIOUSLY INJURED** or **KILLED** by a closing garage door.

- Safety reversal system **MUST** be tested every month.
- After **ANY** adjustments are made, the safety reversal system **MUST** be tested. Door **MUST** reverse on contact with 1-1/2" high (3.8 cm) object (or 2x4 laid flat) on the floor.

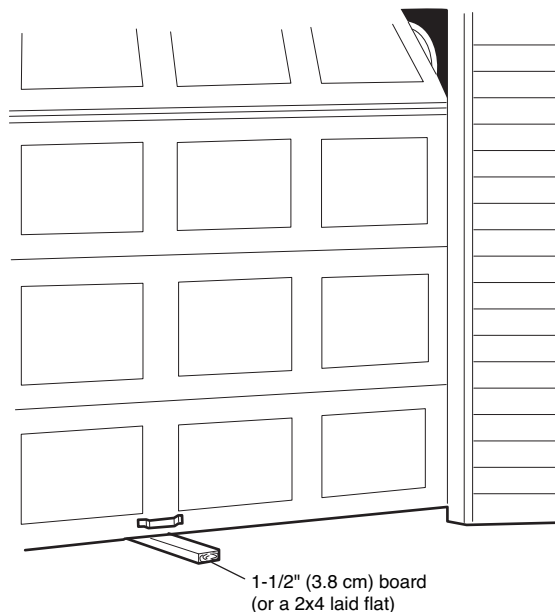

⚠ WARNING

Without a properly installed safety reversing sensor, persons (particularly small children) could be **SERIOUSLY INJURED** or **KILLED** by a closing garage door.

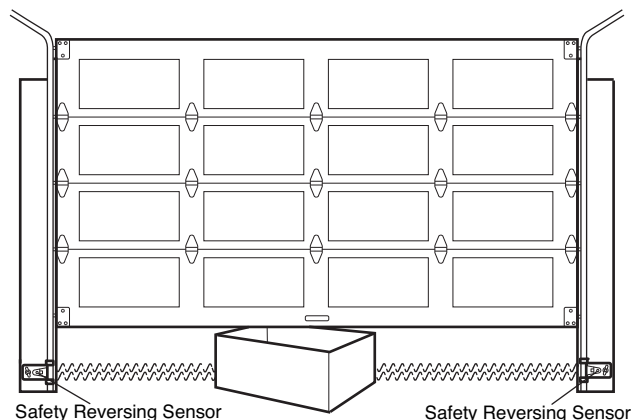

OPERATION

IMPORTANT SAFETY INSTRUCTIONS

WARNING

To reduce the risk of SEVERE INJURY or DEATH:

1. READ AND FOLLOW ALL WARNINGS AND INSTRUCTIONS.
2. ALWAYS keep remote controls out of reach of children. NEVER permit children to operate or play with garage door control push buttons or remote controls.
3. ONLY activate garage door when it can be seen clearly, it is properly adjusted, and there are no obstructions to door travel.
4. ALWAYS keep garage door in sight until completely closed. NO ONE SHOULD CROSS THE PATH OF THE MOVING DOOR.
5. NO ONE SHOULD GO UNDER A STOPPED, PARTIALLY OPEN DOOR.
6. If possible, use emergency release handle to disengage trolley ONLY when garage door is CLOSED. Weak or broken springs or unbalanced door could result in an open door falling rapidly and/or unexpectedly.
7. NEVER use emergency release handle unless garage doorway is clear of persons and obstructions.
8. NEVER use handle to pull garage door open or closed. If rope knot becomes untied, you could fall.
9. If one control (force or travel limits) is adjusted, the other control may also need adjustment.
10. After ANY adjustments are made, the safety reversal system MUST be tested.
11. Safety reversal system MUST be tested every month. Garage door MUST reverse on contact with 1-1/2" high (3.8 cm) high object (or a 2x4 laid flat) on the floor.
12. ALWAYS KEEP GARAGE DOOR PROPERLY BALANCED (see page 3). An improperly balanced door may not reverse when required and could result in SEVERE INJURY or DEATH.
13. ALL repairs to cables, spring assemblies and other hardware, ALL of which are under EXTREME tension, MUST be made by a trained door systems technician.
14. To avoid SERIOUS PERSONAL INJURY or DEATH from electrocution, disconnect ALL electric and battery power BEFORE performing ANY service or maintenance.
15. **SAVE THESE INSTRUCTIONS.**

Using Your Garage Door Opener

Your Security+® opener and hand-held remote control have been factory-set to a matching code which changes with each use, randomly accessing over 100 billion new codes. Your opener will operate with up to eight Security+® remote controls and one Security+® Keyless Entry System. If you purchase a new remote, or if you wish to deactivate any remote, follow the instructions in the *Programming* section.

Activate your opener with any of the following:

- *The hand-held Remote Control:* Hold the large push button down until the door starts to move.
- *The wall-mounted door control:* Hold the push button or bar down until the door starts to move.
- *The Keyless Entry (See Accessories):* If provided with your garage door opener, it must be programmed before use. See *Programming*.

When the opener is activated (with the safety reversing sensor correctly installed and aligned)

1. If open, the door will close. If closed, it will open.
2. If closing, the door will reverse.
3. If opening, the door will stop.
4. If the door has been stopped in a partially open position, it will close.

5. If obstructed while closing, the door will reverse. If the obstruction interrupts the sensor beam, the opener lights will blink for five seconds.
6. If obstructed while opening, the door will stop.
7. If fully open, the door will not close when the beam is broken. The sensor has no effect in the opening cycle.

If the sensor is not installed, or is misaligned, the door won't close from a hand-held remote. However, you can close the door with the door control, the Outside Keylock, or Keyless Entry, *if you activate them until down travel is complete*. If you release them too soon, the door will reverse.

The opener lights will turn on under the following conditions: when the opener is initially plugged in; when power is restored after interruption; when the opener is activated.

They will turn off automatically after 4-1/2 minutes or provide constant light when the Light feature on the Smart Control Panel™ is activated. Bulb size is A19. Bulb power is 100 watts maximum.

Security+® light feature: Lights will also turn on when someone walks through the open garage door. With an Smart Control Panel™, this feature may be turned off as follows: With the opener lights off, press and hold the light button for 10 seconds, until the light goes on, then off again. To restore this feature, start with the opener lights on, then press and hold the light button for 10 seconds until the light goes off, then on again.

Using the Wall-Mounted Door Control

THE SMART CONTROL PANEL™

Press the push bar to open or close the door. Press again to reverse the door during the closing cycle or to stop the door while it's opening.

This door control contains a motion sensing detector that will automatically turn on the light when it detects a person entering the garage.

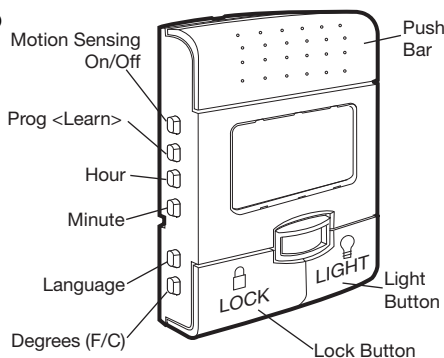

Light feature

Press the Light button to turn the opener light on or off. It will not control the opener lights when the door is in motion. If you turn it on and then activate the opener, the light will remain on for 4-1/2 minutes. Press again to turn it off sooner. The 4-1/2 minute interval can be changed to 1-1/2, 2-1/2, or 3-1/2 minutes as follows: Press and hold the Lock button until the light blinks (about 10 seconds). A single blink indicates that the timer is reset to 1-1/2 minutes. Repeat the procedure and the light will blink twice, resetting the timer to 2-1/2 minutes. Repeat again for a 3-1/2 minute interval, etc., up to a maximum of four blinks and 4-1/2 minutes.

When using the opener lights as working lights, we recommend that you first disable the motion sensor. See *Automatic Light Feature*, below.

Motion Sensing (Automatic Light Feature):

The opener light will turn on automatically when a person enters the garage. When a person walks in front of the door control, the light will come on for five minutes, then shut off. This feature works by detecting body heat.

To disable this feature, push the motion sensing button on the side of the door control.

We recommend that you disable the motion sensor when using the opener lights as working lights. Otherwise, they will turn off automatically if you are working beyond the sensors range.

Lock feature

Designed to prevent operation of the door from hand-held remote controls. However, the door will open and close from the Door Control, the Outdoor Key Switch and the Keyless Entry Accessories.

To activate, press and hold the Lock button for 2 seconds.

To turn off, press and hold the Lock button again for 2 seconds. The Lock feature will also turn off whenever the "learn" button on the motor unit panel is activated.

(PROG) Learn Feature

The door control is equipped with a PROG <LEARN> button to assist in learning remote controls to the unit. Press the PROG <LEARN> button once to initiate LEARN mode and the display will show 'Learn Remote Control - Press Learn Button Again to Confirm'. Press the PROG <LEARN> button a second time and the display will show 'Learn Mode - Press Remote Control Button to Learn Remote.' Press the button of the remote control to be learned and the worklight will blink to confirm the remote control has been learned.

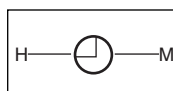

Hour & Minute Feature

Press or hold either of these side buttons to increment the hour or minute displayed on the LCD display.

(LANG) Language Feature

Press this side button to toggle between the three languages - English, French and Spanish.

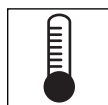

Degrees F/C Feature

Press this side button to toggle the temperature units between Fahrenheit and Celsius.

Display Contrast Adjustment

Press and hold the light button then push the hour button to increase the contrast or the minute button to decrease the contrast.

Using the Remote Control

NOTE: To activate the remote control functions, pull out the plastic pull tab protruding from the remote control housing.

This remote control is equipped with a proximity lighting feature. When moving a hand within close proximity to the remote control, the LED lights turn on for 3 seconds. Upon successful activation of a remote control button, the LED lights will blink rapidly.

Proximity Disable Feature

The remote control will turn off the proximity lighting feature if the proximity lighting is turned on 10 consecutive times without activation of a button. To re-enable the proximity lighting, simply press a button. This function conserves battery life.

To Control the Opener Lights

With 315MHz Security+® remote controls, a remote push button can be programmed to operate the opener lights without opening the door.

1. *With the door closed*, press and hold the remote button that you want to control the light.
2. Press and hold the Light button on the Smart Control Panel™.
3. Press and hold the Lock button on the Smart Control Panel™.
4. After the opener lights flash, release all buttons.

Test by pressing the remote push button. The opener lights should turn on or off but the door should not move.

Troubleshooting

PROBLEM	SOLUTION
Reduced proximity sensing (does not activate by touching top of remote control)	Check if proximity lighting is disabled by pressing a button.
	The Proximity Sensor may be oversensitized. Sit remote control undisturbed for 60 seconds on a non-metallic surface. This allows the sensor to recalibrate itself.
	Replace 3V2450 battery with same type 3V2450 coin cell.
Dim LED lights	Replace two 3V2016 batteries with same type 3V2016 coin cells.
No rapid LED blinking after pressing a button	Replace two 3V2016 batteries with same type 3V2016 coin cells.

The Remote Control Battery

⚠ WARNING

To prevent possible SERIOUS INJURY or DEATH:

- NEVER allow small children near batteries.
- If battery is swallowed, immediately notify doctor.

To reduce risk of fire, explosion or chemical burn:

- Replace ONLY with 3V2016 or 3V2450 coin batteries.
- DO NOT recharge, disassemble, heat above 100°C (212°F) or incinerate.

The 3V2016 lithium batteries for the opener and LED lights (marked “LED and Opener Battery”) should last 5 years. The 3V2450 lithium battery for the proximity lighting (marked “Proximity Battery”) should last 1-2 years.

To replace the batteries, remove the two screws and open the remote control housing. Push the battery out of the holder for removal. Insert replacement batteries positive side up. Dispose of old batteries properly.

Replace the batteries with only 3V2016 or 3V2450 coin cell batteries.

CAUTION: Do not bend spring contact. If bent the proximity sensor will not work.

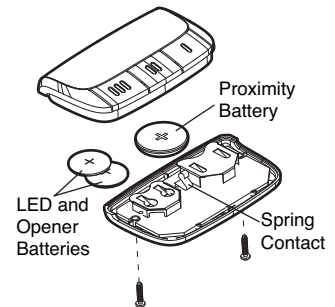

NOTICE: To comply with FCC and/or Industry Canada (IC) rules, adjustment or modifications of this receiver and/or transmitter are prohibited, except for changing the code setting or replacing the battery. THERE ARE NO OTHER USER SERVICEABLE PARTS.

Tested to Comply with FCC Standards FOR HOME OR OFFICE USE. Operation is subject to the following two conditions: (1) this device may not cause harmful interference, and (2) this device must accept any interference received, including interference that may cause undesired operation.

Standby Power (Optional)

OPERATING INSTRUCTIONS

1. Test the installed battery with the motor unit.

To test the battery, disconnect the motor unit power cord from the electrical outlet.

- A solid orange LED indicates the battery is operating on battery power.
- A flashing orange LED with beep indicates the unit is operating on battery power and that the battery charge is low.
- To test the battery is functioning properly, open and close the garage door.
- Re-connect the motor unit power cord back into the electrical outlet.
- Verify that the green LED is flashing on the SPU (indicates that the battery is now charging).
- Test completed.

2. Charge the battery.

- Battery will take 24 to 48 hours to fully charge.

A fully charged battery supplies 12V DC to the motor unit for one to two days of normal operation during an electrical power outage. If the battery voltage drops too low, the batteries will disconnect and the motor unit will no longer operate under battery power.

After the electrical power has been restored, the battery will recharge within 48 hours. Under normal usage batteries will last 3 to 5 years.

To obtain maximum battery life and prevent damage, disconnect the battery when motor unit is unplugged for an extended period of time.

NOTE: Door operation may be limited until battery is fully charged. The motor unit's lights will not turn on during battery mode.

WARNING

To reduce the risk of FIRE or INJURY to persons:

- Disconnect ALL electric and battery power BEFORE performing ANY service or maintenance.
- Use ONLY LiftMaster part number 485LM for replacement battery.
- Do NOT dispose of battery in fire. Battery may explode. Check with local codes for disposal instructions.

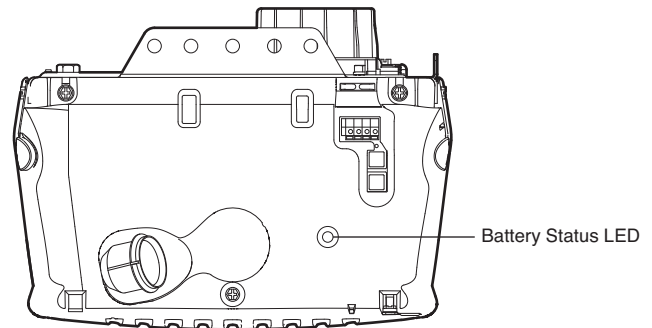

NOTE: LED is most visible with worklight off.

GREEN LED:

All systems are normal.

- A solid LED light indicates the battery is fully charged.
- A flashing LED indicates the battery is being charged.

NOTE: Battery do not have to be fully charged to operate the motor unit.

ORANGE LED:

The motor unit has lost power and is operating off of the battery.

- A solid LED with beep, sounding approximately every 2 seconds, indicates the motor unit is activating the door and is operating off of the battery.
- A flashing LED with beep, sounding every 30 seconds, indicates battery is low.
- Once the power is restored the battery will recharge. This is indicated by a flashing green LED.

RED LED:

- If a red LED remains on when the power is restored, and is accompanied by a beep sounding every 30 seconds, please call for service.
- To obtain maximum battery life and prevent damage, also disconnect the battery if you unplug the motor unit while on vacation or any other extended period of time.

To Open the Door Manually

WARNING

To prevent possible **SERIOUS INJURY** or **DEATH** from a falling garage door:

- If possible, use emergency release handle to disengage trolley **ONLY** when garage door is **CLOSED**. Weak or broken springs or unbalanced door could result in an open door falling rapidly and/or unexpectedly.
- **NEVER** use emergency release handle unless garage doorway is clear of persons and obstructions.
- **NEVER** use handle to pull door open or closed. If rope knot becomes untied, you could fall.

The door should be fully closed if possible. Pull down on the emergency release handle and lift the door manually. To reconnect the door to the opener, press the door control push bar.

The *lockout feature* prevents the trolley from reconnecting automatically. Pull the emergency release handle down and back (toward the opener). The door can then be raised and lowered manually as often as necessary. To disengage the lockout feature, pull the handle straight down. The trolley will reconnect on the next UP or DOWN operation, either manually or by using the door control or remote.

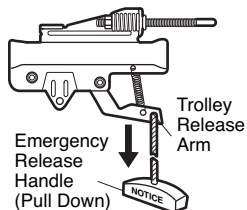

MANUAL DISCONNECT POSITION

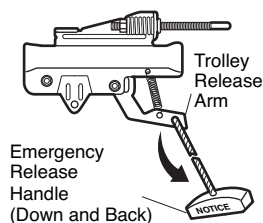

LOCKOUT POSITION

CARE OF YOUR OPENER

MAINTENANCE SCHEDULE

Once a Month

- Manually operate door. If it is unbalanced or binding, call a trained door systems technician.
- Check to be sure door opens & closes fully. Adjust limits and/or force if necessary (see pages 23 and 24).
- Repeat the safety reverse test. Make any necessary adjustments (see Adjustment Step 3).

Once a Year

- Oil door rollers, bearings and hinges. The opener does not require additional lubrication. Do not grease the door tracks.

Having a Problem (Troubleshooting)

NOTE: Always unplug battery prior to troubleshooting.

1. My door will not close and the light bulbs blink on my motor unit: The safety reversing sensor must be connected and aligned correctly before the garage door opener will move in the down direction.

- Verify the safety reversing sensors are properly installed, aligned and free of any obstructions. Refer to *Installation Step 10: Install The Protector System®*.
- Check diagnostic LED for flashes on the motor unit then refer to the *Diagnostic Chart* on the following page.

2. My remotes will not activate the door:

- Verify your Smart Control Panel™ does not display “Lock Mode.” If it does, deactivate the Lock Mode following the instructions for *Using the Door Control*.
- Reprogram remotes following the programming instructions. Refer to *Programming*.
- If remote will still not activate your door, check diagnostic LED for flashes on motor unit then refer to *Diagnostic Chart* on the following page.

3. My door reverses for no apparent reason: Repeat safety reverse test after adjustments to force or travel limits. The need for occasional adjustment for the force and limit settings is normal. Weather conditions in particular can affect door travel.

- Manually check door for balance or any binding problems.
- Refer to *Adjustment Step 2, Setting the Force*.

4. My door reverses for no apparent reason after fully closing and touching the floor: Repeat safety reverse test after adjustments to force or travel limits. The need for occasional adjustment for the force and limit settings is normal. Weather conditions in particular can affect door travel.

- Refer to *Adjustment Step 1, Program the Travel Limits*. Decrease down travel.

5. My lights will not turn off when door is open:

- The garage door opener is equipped with a security light feature. This feature activates the light on when the safety reversing sensor beam has been obstructed. Refer to Operation section; Using the *Wall Mounted Door Control, Light Feature*.

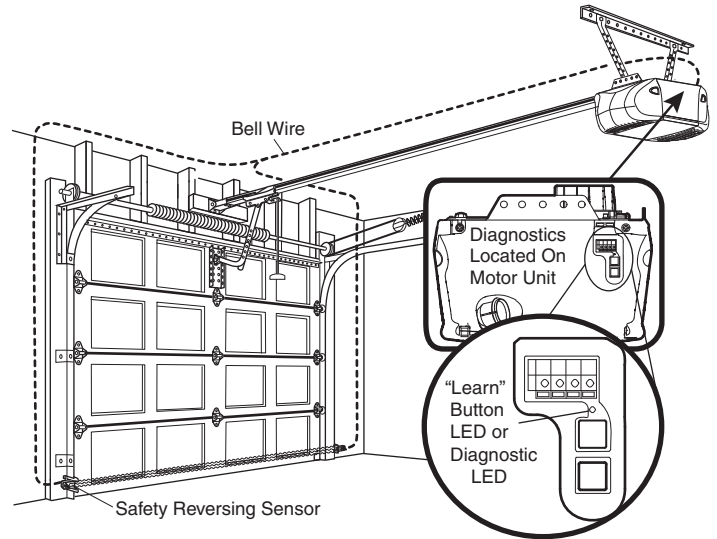

Sending Eye Safety Reversing Sensor (Amber Indicator Light)

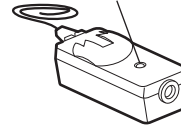

Receiving Eye Safety Reversing Sensor (Green Indicator Light)

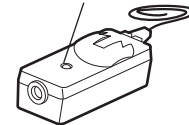

6. My motor unit hums briefly:

- First verify that the trolley is against the stop bolt.
- Release the door from the opener by pulling the Emergency Release Rope.
- Manually bring the door to a closed position.
- Loosen the belt by adjusting the *outer nut* 4 to 5 turns. This relieves the tension.
- Run the motor unit from the remote control or door control. The trolley should travel towards the door and stop. If the trolley re-engages with the door, pull the Emergency Release Rope to disengage.
- Decrease the UP travel by turning the UP Travel adjustment screw 2 full turns *away* from the arrow.

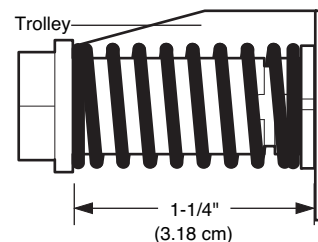

- Re-Tighten the outer nut until the trolley spring is approximately 1-1/4" (3.18 cm) in length.
- If the trolley does not move away from the bolt, repeat the steps above.

7. If battery status LED is not lit properly:

- Check battery connections.

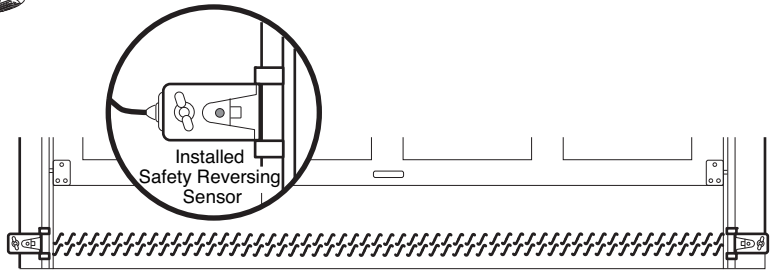
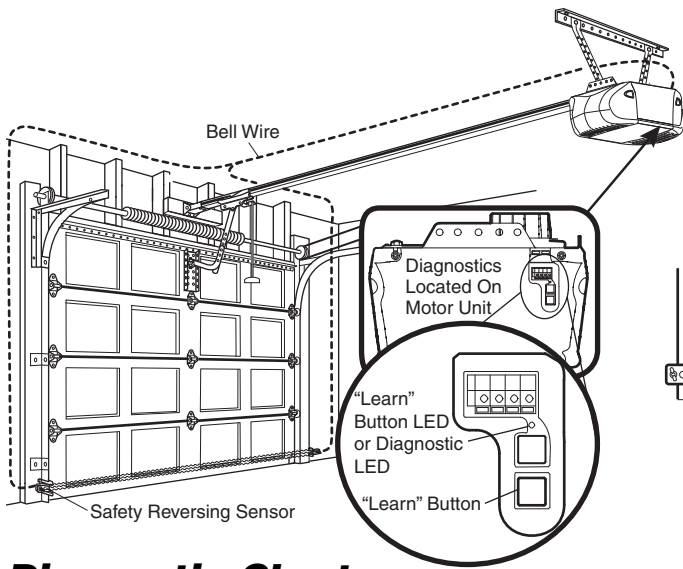

Your garage door opener is programmed with self-diagnostic capabilities. The "Learn" button/diagnostic LED will flash a number of times then pause signifying it has found a potential issue. Consult Diagnostic Chart below.

Diagnostic Chart

1 FLASH

Safety reversing sensors wire open (broken or disconnected).

OR

2 FLASHES

Safety reversing sensors wire shorted or black/white wire reversed.

3 FLASHES

Door control or wire shorted.

4 FLASHES

Safety reversing sensors slightly misaligned (dim or flashing LED).

5 FLASHES

Possible RPM sensor failure. Unplug to reset.

● **Symptom: One or both of the Indicator lights on the safety reversing sensors do not glow steady.**

- Inspect sensor wires for a short (staple in wire), correct wiring polarity (black/white wires reversed), broken or disconnected wires, replace/attach as needed.
- Disconnect all wires from back of motor unit.
- Remove sensors from brackets and shorten sensor wires to 1-2 ft (30-60 cm) from back each of sensor.
- Reattach sending eye to motor unit using shortened wires. If sending eye indicator light glows steadily, attach the receiving eye.
- Align sensors, if the indicator lights glow replace the wires for the sensors. If the sensor indicator lights do not light, replace the safety reversing sensors.

● **Symptom: LED is not lit on door control.**

- Inspect door control/wires for a short (staple in wire), replace as needed.
- Disconnect wires at door control, touch wires together. If motor unit activates, replace door control.
- If motor unit does not activate, disconnect door control wires from motor unit. Momentarily short across red and white terminals with jumper wire. If motor unit activates, replace door control wires.

● **Symptom: Sending indicator light glows steadily, receiving indicator light is dim or flashing.**

- Realign receiving eye sensor, clean lens and secure brackets.
- Verify door track is firmly secured to wall and does not move.

● **Symptom: RPM Sensor = Short travel 6-8" (15-20 cm).**

- Unplug unit to reset. Try to operate motor unit, check diagnostic code.
- If it is still flashing 5 times and motor unit moves 6-8" (15-20 cm), replace RPM sensor.

Smart Control Panel™ Messages

The following messages are contained within the Smart Control Panel™ and may appear during the operations of the unit:

Message

SAFETY SENSORS
CHECK ALIGNMENT,
BLOCKAGE OR
MISWIRING. SEE
OWNER'S MANUAL.

- **Meaning:** This message will appear if the Safety Reversing Sensors are out of alignment, if they are blocked or if the wiring is disconnected. To clear message from door control do the following:
 - Check to see that area is clear between the Safety Reversing Sensors.
 - Check to see that the Safety Reversing Sensors are not misaligned.
 - Realign receiving eye sensor, clean lens and secure brackets.
 - Verify door track is firmly secured to wall and does not move.
 - Check to see that the Safety Reversing Sensors' wires are connected to the motor unit.
 - If message has not cleared after the above checks, refer to message #2.

Message

SAFETY SENSORS
MALFUNCTION.
CHECK MISWIRING.
SEE OWNER'S
MANUAL.

- **Meaning:** This message will appear if the Safety Reversing Sensors are miswired. To clear the message, do the following:
 - Inspect the safety sensor wires for a short (staple in wire), correct wiring polarity (black/white wires reversed), replace/attach as needed.
 - Disconnect all wires from back of motor unit.
 - Remove safety sensors from brackets and shorten sensor wires to 1-2 ft. (30-60 cm) from back of each sensor.
 - Reattach sending eye to motor unit using shortened wires. If sending eye indicator light glows steadily, attach the receiving eye.
 - Align sensors, if the indicator lights glow replace the wires for the sensors. If the sensor indicator lights do not light, replace the safety sensors.

Message

LEARN REMOTE
CONTROL. PRESS
LEARN BUTTON TO
CONFIRM.

- **Meaning:** This message will appear when the Prog <LEARN> button has been pressed on the door control. Pressing the Prog <LEARN> button again will allow the user to program an additional remote control to the opener.

Message

LEARN MODE.
PRESS REMOTE
CONTROL BUTTON
TO PROGRAM
REMOTE.

- **Meaning:** This message will appear when the Prog <learn> button has been pressed a second time on the door control or anytime on the opener. The opener is ready to program another remote control by simply pressing the remote control button. Once the opener has 'LEARNED' the remote control, the worklight will blink one time.

Message

LOCK MODE.
REMOTE CONTROL
LOCKED OUT.
PRESS LOCK
BUTTON TO ENABLE
REMOTE.

- **Meaning:** This message will appear when the 'Lock' button has been pressed and held for more than one second. This feature will disable the opener from receiving remote control signals. To exit 'LOCK' mode, press and hold the button for more than one second.

Message

ENGLISH, FRANÇAIS
AND ESPAÑOL.

- **Meaning:** This message will appear when the 'Language' button has been pressed. Pressing the button will toggle to the next language.

Message

MOTION SENSING
ON, MOTION
SENSING OFF.

- **Meaning:** This message will appear when the 'MOTION SENSING' button is pressed. The Motion Detector will toggle on or off with each press of the button.

PROGRAMMING

NOTICE: If this Security+® garage door opener is operated with a non-rolling code remote control, the technical measure in the receiver of the garage door opener, which provides security against code-theft devices, will be circumvented. The owner of the copyright in the garage door opener does not authorize the purchaser or supplier of the non-rolling code remote control to circumvent that technical measure.

Your garage door opener has already been programmed at the factory to operate with your hand-held remote control. The door will open and close when you press the large push button.

Below are instructions for programming your opener to operate with additional 315MHz Security+® remote controls.

To Add or Reprogram a Hand-held Remote Control

USING THE “LEARN” BUTTON

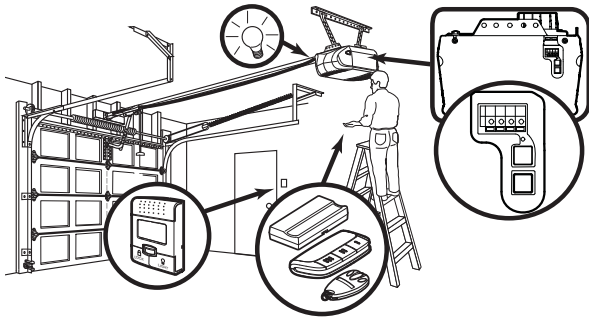

1. Press and release the “learn” button on the motor unit. The learn indicator light will glow steadily for 30 seconds.
2. Within 30 seconds, press and hold the button on the hand-held remote* that you wish to operate your garage door.
3. Release the button when the motor unit lights blink. It has learned the code. If light bulbs are not installed, two clicks will be heard.

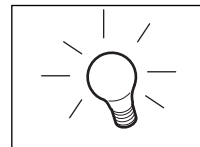
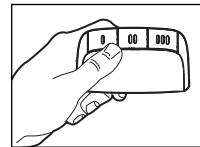
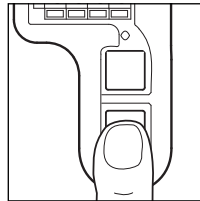

USING THE SMART CONTROL PANEL™

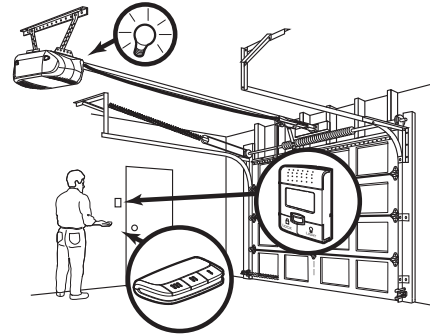

1. Press the PROG <Learn> button on the Smart Control Panel™.
2. Press the PROG <Learn> button again to confirm Learn Mode.
3. Press the button on the hand-held remote that you wish to operate your garage door.
4. When the motor unit lights blink, it has learned the code. If light bulbs are not installed, two clicks will be heard.

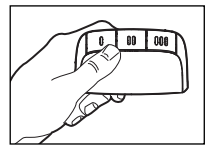
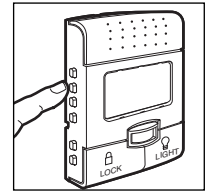
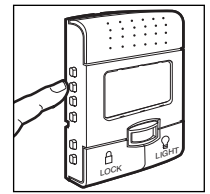

To Erase All Codes From Motor Unit Memory

To deactivate any unwanted remote, first erase all codes:

Press and hold the “learn” button on motor unit until the learn indicator light goes out (approximately 6 seconds). All previous codes are now erased. Reprogram each remote or keyless entry you wish to use.

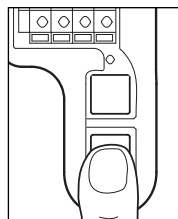

*3-Button Remotes (315MHz)

If provided with your garage door opener, the large button is factory programmed to operate it. Additional buttons on any Security+® 3-button remote or mini-remote can be programmed to operate other Security+® garage door openers.

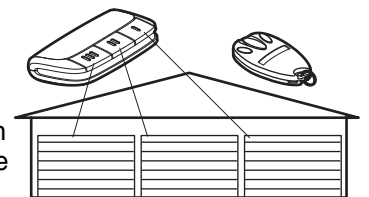

To Add, Reprogram or Change a Keyless Entry PIN

NOTE: Your new Keyless Entry must be programmed to operate your garage door opener.

USING THE "LEARN" BUTTON

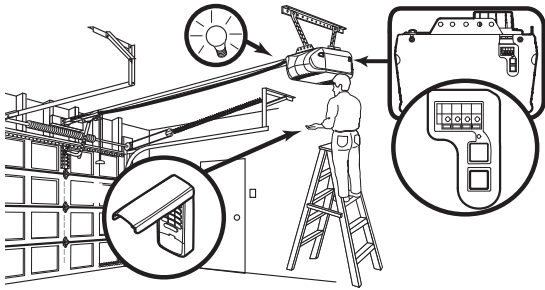

1. Press and release the "learn" button on motor unit. The learn indicator light will glow steadily for 30 seconds.
2. Within 30 seconds, enter a four digit personal identification number (PIN) of your choice on the keypad. Then press and hold the enter button.
3. Release the button when the motor unit lights blink. It has learned the code. If light bulbs are not installed, two clicks will be heard.

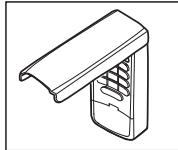
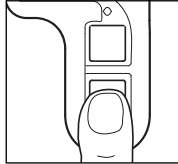

To change an existing, known PIN

If the existing PIN is known, it may be changed by one person without using a ladder.

1. Press the four buttons for the present PIN, then press and hold the # button.
The opener light will blink twice. Release the # button.
2. Press the new 4-digit PIN you have chosen, then press Enter.

The motor unit lights will blink once when the PIN has been learned.

Test by pressing the new PIN, then press Enter. The door should move.

To set a temporary PIN

You may authorize access by visitors or service people with a temporary 4-digit PIN. After a programmed number of hours or number of accesses, this temporary PIN expires and will no longer open the door. It can be used to *close* the door even after it has expired. To set a temporary PIN:

1. Press the four buttons for your personal entry PIN (not the last temporary PIN), then press and hold the * button.
The opener light will blink three times. Release the button.

One Button Close: Opener can be closed by pressing only the ENTER button if the one button close feature has been activated. This feature has been activated at the factory. To activate or deactivate this feature press and hold buttons 1 and 9 for 10 seconds. The keypad will blink twice when the one button close is active. The keypad will blink four times when one button close is deactivated.

USING THE SMART CONTROL PANEL™

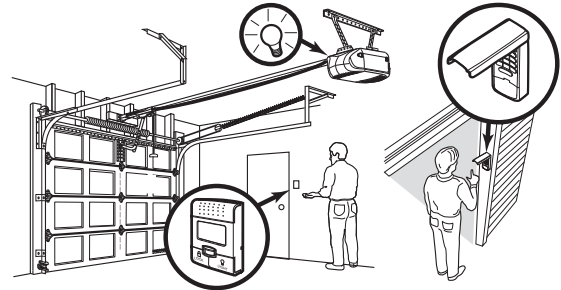

NOTE: This method requires two people if the Keyless Entry is already mounted outside the garage.

1. Press the PROG <Learn> button on the Smart Control Panel™.
2. Press the PROG <Learn> button again to confirm Learn Mode.
3. Enter a four digit personal identification number (PIN) of your choice on the keypad. Then press enter.
4. When the motor unit lights blink, it has learned the code. If light bulbs are not installed, two clicks will be heard.

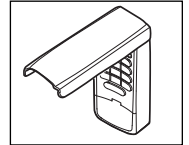
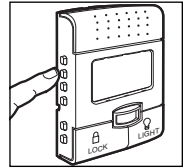
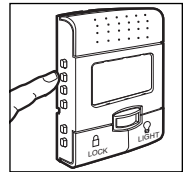

2. Press the temporary 4-digit PIN you have chosen, then press Enter.
The opener light will blink four times.
3. To set the number of **hours** this temporary PIN will work, press the number of hours (up to 255), then press *.

OR

3. To set the number of **times** this temporary PIN will work, press the number of times (up to 255), then press #.
The opener light will blink once when the temporary PIN has been learned.

Test by pressing the four buttons for the temporary PIN, then press Enter. The door should move. If the temporary PIN was set to a certain number of openings, remember that the test has used up one opening. To clear the temporary password, repeat steps 1-3, setting the number of hours or times to 0 in step 3.

REPAIR PARTS

Rail Assembly Parts

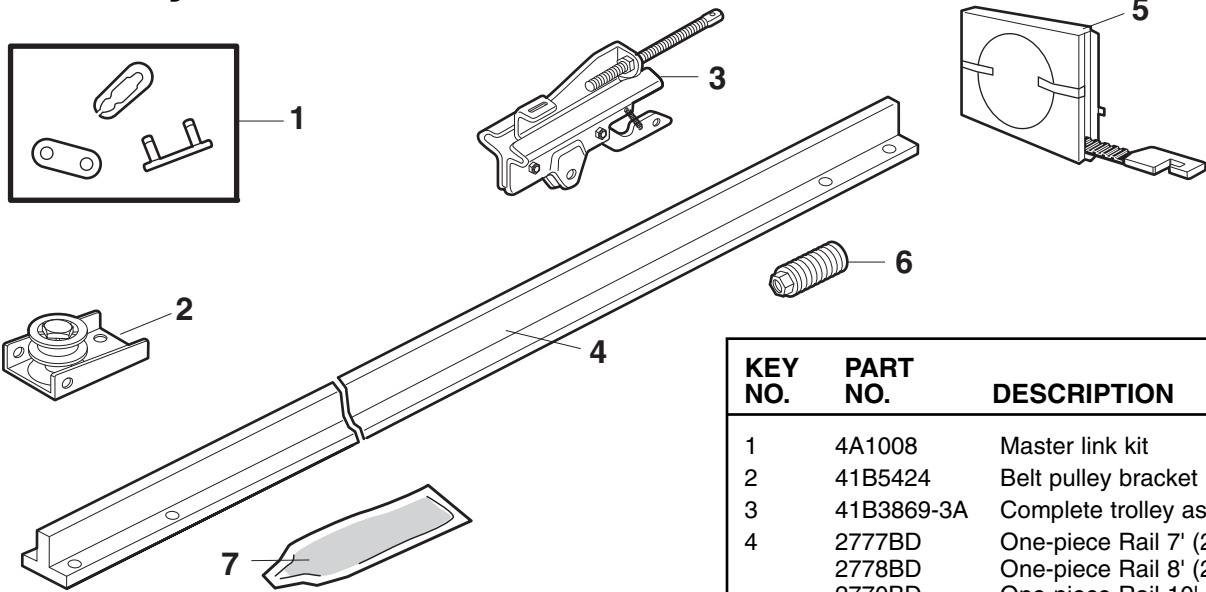

KEY NO.	PART NO.	DESCRIPTION
1	4A1008	Master link kit
2	41B5424	Belt pulley bracket
3	41B3869-3A	Complete trolley assembly
4	2777BD	One-piece Rail 7' (2.1 m)
	2778BD	One-piece Rail 8' (2.4 m)
	2770BD	One-piece Rail 10' (3 m)
5	41A5434-11	Full belt assembly
6	41B4103	Tensioner assembly
7	83A11-2	Rail grease

Installation Parts

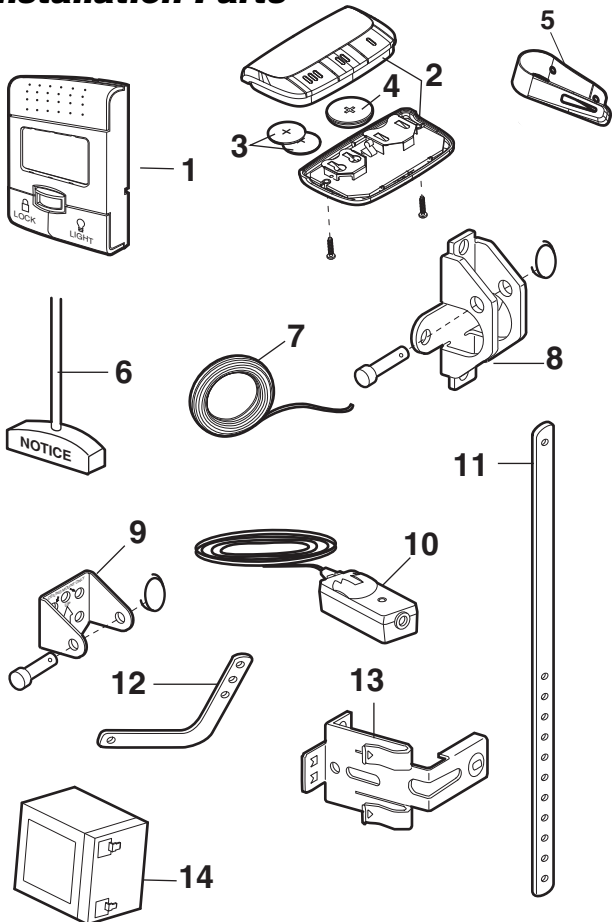

KEY NO.	PART NO.	DESCRIPTION
1	398LM	Smart Control Panel™
2	373P	3-Button remote control
3	10A19	3V2016 Lithium battery: LED and opener
4	10A33	3V2450 Lithium battery: proximity switch
5	29C151	Remote control visor clip
6	41A2828	Emergency release rope and handle assembly
7	41B4494-1	2-Conductor bell wire, white & white/red
8	41A5047-1	Door bracket w/ clevis pin & fastener
9	41A4353-1	Header bracket w/clevis pin & fastener
10	41A5034	Safety sensor kit (receiving and sending eyes) with 3' (.9 m) 2-conductor bell wire
11	178B34	Straight door arm section
12	178B35	Curved door arm section
13	41A5266-1	Safety sensor brackets (2)
14	485LM	Battery
		NOT SHOWN
	101D173	Push bar for door control
	41A2770-13	Installation hardware bag (includes hardware listed on page 5).
	114A3406	Owner's manual
	114A3406SP	Owner's manual - Spanish

Motor Unit Assembly Parts

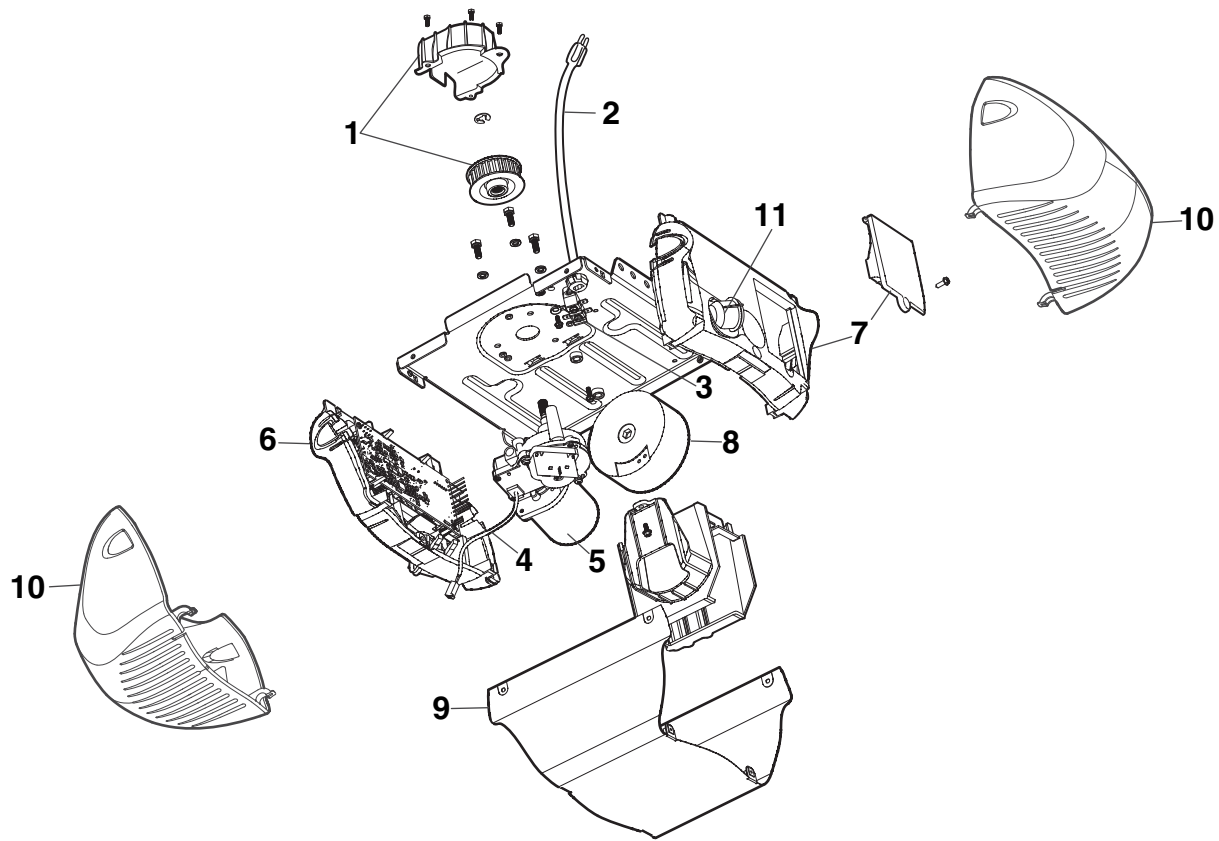

KEY NO.	PART NO.	DESCRIPTION	KEY NO.	PART NO.	DESCRIPTION
1	41C76	Belt cap and sprocket	7	41A6231	End panel with battery door and screw
2	41B4245	Line cord	8	41C190	Transformer and harness
3	41B4375-3	Terminal block with screws	9	41D504-4	Cover
4	41A6281	Wire harness kit	10	108D79	Light lens
5	41D794	Motor with positioning sensor	11	4A1344	Light socket
6	41DB002-2	Receiver logic assembly			
					NOT SHOWN
				485LM	Battery kit

ACCESSORIES

1702LM

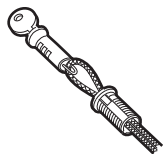

Outside Quick Release:

Required for a garage with NO access door. Enables homeowner to open garage door manually from outside by disengaging trolley.

41A5281

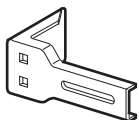

Extension Brackets:

(Optional) For safety sensor installation onto the wall or floor.

377LM

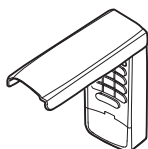

SECURITY+ Keyless Entry:

Enables homeowner to operate garage door opener from outside by entering a password on a specially designed keyboard. Also can add a temporary password for visitors or service persons. This temporary password can be limited to a programmable number of hours or entries.

915LM



Garage Door Monitor:

Security for the largest door of your home!

Tells you if your garage door is open or closed. Monitors up to 4 garage doors by adding additional sensor modules.

395LM

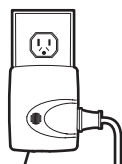

Remote Light Control:

Enables homeowner to turn on a lamp, television or other appliance from car, bedside, or anywhere in the home with a remote.

373W



Designer Burlled Walnut 3-Button Remote Control with Security+:

Includes visor clip.

373P



SECURITY+ 3-Button Remote Control:

Includes visor clip.

374LM



SECURITY+ 4-Button Remote Control:

Includes visor clip.

370LM



SECURITY+ 3-Button Mini Remote Control:

With key ring and fastening strip.

378LM

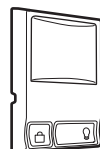

Wireless Door Control:

Push bar, light feature and auxiliary button. Includes battery.

485LM

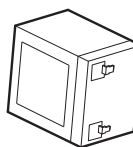

Standby Power System:

Provides backup power to the garage door opener. For use with model 3850 only.

975LM



Laser Park Assist:

Laser enables homeowners to precisely park vehicles in the garage.

990LM

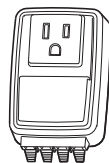

Surge Protector:

The Garage Door Opener Surge Protector is designed to protect LiftMaster® garage door openers against damage from lightning and power surges.

LIFTMASTER® SERVICE IS ON CALL

OUR LARGE SERVICE ORGANIZATION
SPANS AMERICA

INSTALLATION AND SERVICE INFORMATION IS AS NEAR
AS YOUR TELEPHONE. SIMPLY DIAL OUR
TOLL FREE NUMBER:

1-800-528-9131

www.liftmaster.com

For professional installation, parts and service, contact your local LIFTMASTER/CHAMBERLAIN dealer. Look for him in the Yellow Pages, or call our Service number for a list of dealers in your area.

HOW TO ORDER REPAIR PARTS

Selling prices will be furnished on request or parts will be shipped at prevailing prices and you will be billed accordingly.

WHEN ORDERING REPAIR PARTS, ALWAYS GIVE THE
FOLLOWING INFORMATION:

- PART NUMBER
- PART NAME
- MODEL NUMBER

ADDRESS ORDERS TO:
THE CHAMBERLAIN GROUP, INC.
Technical Support Group
6050 S. Country Club Road
Tucson, Arizona 85706

SERVICE INFORMATION
TOLL FREE NUMBER:

1-800-528-9131

LIFTMASTER FIVE YEAR LIMITED WARRANTY LIFETIME MOTOR AND BELT LIMITED WARRANTY

The Chamberlain Group, Inc. ("Seller") warrants to the first retail purchaser of this product, for the residence in which this product is originally installed, that it is free from defect in materials and/or workmanship for a period of 60 full months from the date of purchase [and that the motor and belt] are free from defect in materials and/or workmanship for a period of the lifetime of the product]. The proper operation of this product is dependent on your compliance with the instructions regarding installation, operation, maintenance and testing. Failure to comply strictly with those instructions will void this limited warranty in its entirety.

If, during the limited warranty period, this product appears to contain a defect covered by this limited warranty, call 1-800-528-9131, toll free, before dismantling this product. Then send this product, pre-paid and insured, to our service center for warranty repair. You will be advised of shipping instructions when you call. Please include a brief description of the problem and a dated proof-of-purchase receipt with any product returned for warranty repair. Products returned to Seller for warranty repair, which upon receipt by Seller are confirmed to be defective and covered by this limited warranty, will be repaired or replaced (at Seller's sole option) at no cost to you and returned pre-paid. Defective parts will be repaired or replaced with new or factory-rebuilt parts at Seller's sole option.

ALL IMPLIED WARRANTIES FOR THE PRODUCT, INCLUDING BUT NOT LIMITED TO ANY IMPLIED WARRANTIES OF MERCHANTABILITY AND FITNESS FOR A PARTICULAR PURPOSE, ARE LIMITED IN DURATION TO THE FIVE YEAR LIMITED WARRANTY PERIOD SET FORTH ABOVE [EXCEPT THE IMPLIED WARRANTIES WITH RESPECT TO THE MOTOR AND BELT, WHICH ARE LIMITED IN DURATION TO THE LIFETIME LIMITED WARRANTY PERIOD FOR THE MOTOR AND BELT], AND NO IMPLIED WARRANTIES WILL EXIST OR APPLY AFTER SUCH PERIOD. Some States do not allow limitations on how long an implied warranty lasts, so the above limitation may not apply to you. THIS LIMITED WARRANTY DOES NOT COVER NON-DEFECT DAMAGE, DAMAGE CAUSED BY IMPROPER INSTALLATION, OPERATION OR CARE (INCLUDING, BUT NOT LIMITED TO ABUSE, MISUSE, FAILURE TO PROVIDE REASONABLE AND NECESSARY MAINTENANCE, UNAUTHORIZED REPAIRS OR ANY ALTERATIONS TO THIS PRODUCT), LABOR CHARGES FOR REINSTALLING A REPAIRED OR REPLACED UNIT, REPLACEMENT OF BATTERIES AND LIGHT BULBS OR UNITS INSTALLED FOR NON-RESIDENTIAL USE.

THIS LIMITED WARRANTY DOES NOT COVER ANY PROBLEMS WITH, OR RELATING TO, THE GARAGE DOOR OR GARAGE DOOR HARDWARE, INCLUDING BUT NOT LIMITED TO THE DOOR SPRINGS, DOOR ROLLERS, DOOR ALIGNMENT OR HINGES. THIS LIMITED WARRANTY ALSO DOES NOT COVER ANY PROBLEMS CAUSED BY INTERFERENCE. ANY SERVICE CALL THAT DETERMINES THE PROBLEM HAS BEEN CAUSED BY ANY OF THESE ITEMS COULD RESULT IN A FEE TO YOU.

UNDER NO CIRCUMSTANCES SHALL SELLER BE LIABLE FOR CONSEQUENTIAL, INCIDENTAL OR SPECIAL DAMAGES ARISING IN CONNECTION WITH USE, OR INABILITY TO USE, THIS PRODUCT. IN NO EVENT SHALL SELLER'S LIABILITY FOR BREACH OF WARRANTY, BREACH OF CONTRACT, NEGLIGENCE OR STRICT LIABILITY EXCEED THE COST OF THE PRODUCT COVERED HEREBY. NO PERSON IS AUTHORIZED TO ASSUME FOR US ANY OTHER LIABILITY IN CONNECTION WITH THE SALE OF THIS PRODUCT.

Some states do not allow the exclusion or limitation of consequential, incidental or special damages, so the above limitation or exclusion may not apply to you. This limited warranty gives you specific legal rights, and you may also have other rights which vary from state to state.