

OPERATOR'S MANUAL

650475-X

INCLUDING: SERVICE KITS, GENERAL DESCRIPTION & TROUBLESHOOTING
ALSO INCLUDE MANUALS: 65465-B AIR MOTOR, 6693X-X LOWER PUMP, FORM 3637-2
GENERAL INFORMATION SHEET.

RELEASED:12-12-90
REVISED:6-14-10
(REV. C) IPP

4-1/4" AIR MOTOR
35:1 RATIO
6" STROKE

TWO-BALL PUMP (CARBON STEEL)

**IMPORTANT: READ THIS MANUAL CAREFULLY BEFORE INSTALLING,
OPERATING OR SERVICING THIS EQUIPMENT.**

(PACKINGS ARE UPPER AND LOWER UNLESS NOTED)

PACKING MATERIAL

- 1 THIOLKOL LEATHER
- 3 GLASS FILLED PTFE
- 5 PTFE (GF) / LEATHER STG'D (UPPER)
GLASS FILLED PTFE (LOWER)
- 9 (G/F) PTFE / LEATHER STG'D
- A UHMW-PE (UPPER)
LEATHER (LOWER)
- B UHMW-PE (UPPER)
PTFE (LOWER)
- C UHMW-PE
- D UHMW-PE / LEATHER STG'D (UPPER)
LEATHER (LOWER)

PACKING MATERIAL

- E UHMW-PE / LEATHER STG'D (UPPER)
PTFE (LOWER)
- F UHMW-PE / LEATHER STG'D (UPPER)
UHMW-PE (LOWER)
- G UHMW-PE / LEATHER STG'D
- N LEATHER (UPPER)
PTFE (LOWER)
- P UHMW-PE / PTFE STG'D (UPPER)
UHMW-PE (LOWER)
- R PTFE / UHMW-PE STG'D (UPPER)
PTFE (LOWER)

PUMP OPTION DESCRIPTION CHART 650475-XXX



SPRING ARRANGEMENT

- 1 COIL SPRING
- 5 COMPOSITE SPRING W / ADJ. P'KG NUT

PLUNGER TYPE

- 3 HD SS W / HD CHROME PLATING

SERVICE KITS

- Use only genuine ARO® replacement parts to assure compatible pressure rating and longest service life.
- 61268 for general repair of the Air Motor section.
- 637200-XXX for general repair of the 66930-XXX (Two-Ball) Lower Pump End.

GENERAL DESCRIPTION

⚠ WARNING HAZARDOUS PRESSURE. Do not exceed maximum operating pressure of 5,250 psi (365 bar) at 150 psi (10.4 bar) inlet air pressure.

⚠ WARNING Refer to general information sheet for additional safety precautions and important information.

- This MODEL MANUAL is one of four documents needed to properly support an ARO pump model. Ref: Part A. 650XXX-XXX-X MODEL (OPERATOR'S) MANUAL, Part B. GENERAL INFORMATION, Part C. AIR MOTOR (OPERATOR'S) MANUAL, Part D. LOWER PUMP END (OPERATOR'S) MANUAL. These forms are available from the factory if needed.
- The Two-Ball pumps are primarily designed for the pumping of medium viscosity fluids compatible with carbon steel. The lower pump is designed for easy priming and the double acting feature is standard in all ARO industrial pumps. Material is delivered to the pump discharge outlet on both the up and down stroke.
- The motor is connected to the lower pump end by a spacer section. This allows for lubrication of the upper packing gland and prevents motor contamination because of normal wear and eventual leakage through the material packing gland.

PUMP DATA

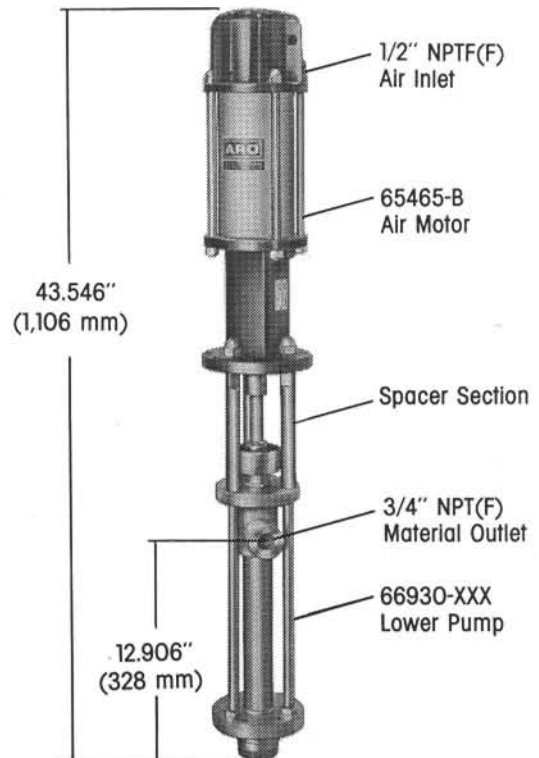

FIGURE 1

INGERSOLL RAND COMPANY LTD

209 NORTH MAIN STREET - BRYAN, OHIO 43306

☎ (800) 495-0276 • FAX(800) 892-6276

© 2010

www.ingersollrandproducts.com

ARO

IR Ingersoll Rand
Industrial Technologies

PUMP DISASSEMBLY

Refer to Figure 2.

1. Lay the pump assembly on a workbench.
2. Remove the three (E) nuts from the three (F) spacer rods.
3. Pull the air motor from the lower pump end until air motor piston rod is on "down" position and lower pump end rod is in "up" position.
4. Slide (A) retaining ring upward.
NOTE: A snap ring tool is recommended for proper handling of retaining ring.
5. Slide (B) sleeve towards air motor on the air motor piston rod.
6. Remove two (C) connectors and lay air motor aside.
7. Repeat steps, 4, 5, and 6 to remove other connector. Then remove (D) extension rod.
8. Unscrew three (F) spacer rods only if disassembly of lower pump end is necessary.

PUMP ASSEMBLY

Note: All threads are right hand.

1. Align Lower End Pump Rod with (D) extension rod and Air Motor Piston rod. Position air inlet of motor 65° from material outlet.
2. Position two (C) connectors in place and slide (B) sleeve over two (C) connectors.
3. Slide (A) retaining ring into groove.
NOTE: Repeat step 2 to secure other connector to (D) extension rod.
4. If three (F) spacer rods were removed in step 8 of disassembly of air motor from lower pump end, screw spacer rods into lower pump end.
5. Push air motor and lower pump end together so spacer rods slide thru holes located in air motor base.
6. Secure air motor to lower pump end using three (E) nuts.

TROUBLE SHOOTING

• PROBLEM

___Cause, solution.

• Pump will not cycle.

- ___No pressure to motor, See motor manual.
- ___Restricted return lines, clean obstruction.
- ___Damaged motor, service motor.

___Be sure to eliminate any possible non-pump problems before suspecting pump malfunction and continuing.

• Pump problems will typically occur in one of two areas:

1. The Air Motor Section.
2. The Lower Pump Section.

___Determine which section is affected.

SPACER SECTION

REF	PART NO.	DESCRIPTION
A	90102 (2)	RETAINING RING
B	90109 (2)	SLEEVE
C	90096 (4)	CONNECTOR
D	90163-4	EXTENSION ROD
E	Y85-29-C (3)	HEX HEAD NUT
F	90531 (3)	SPACER ROD

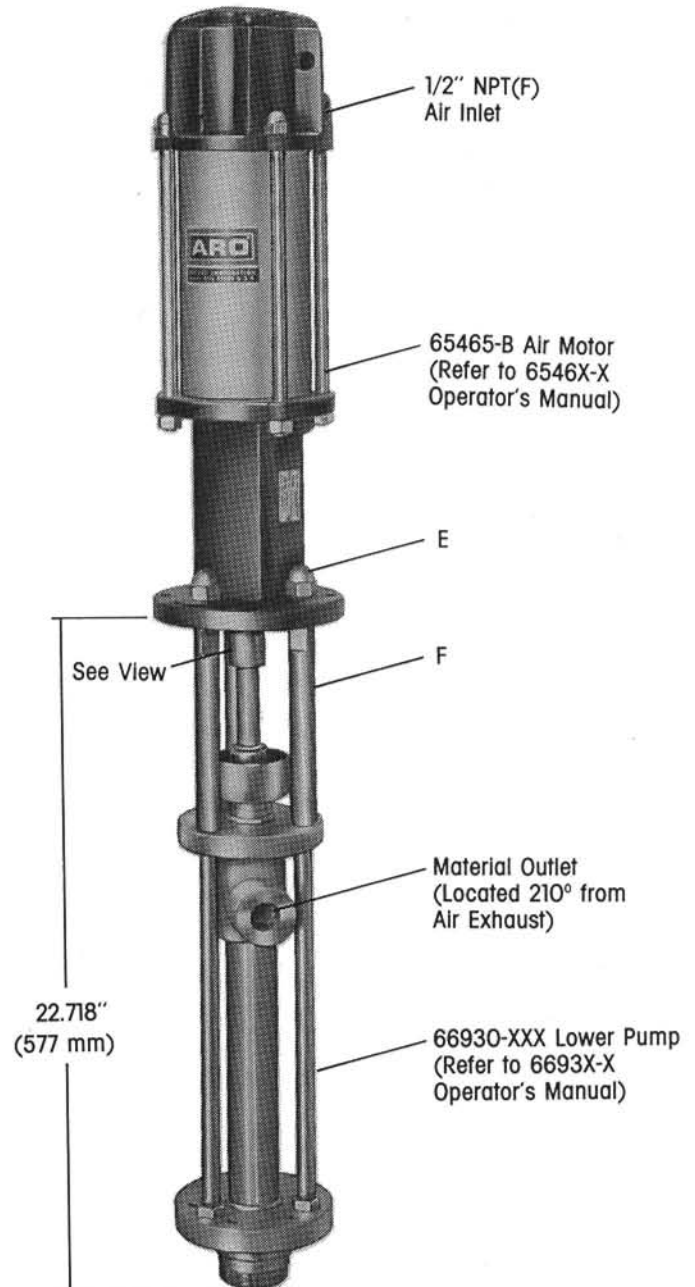
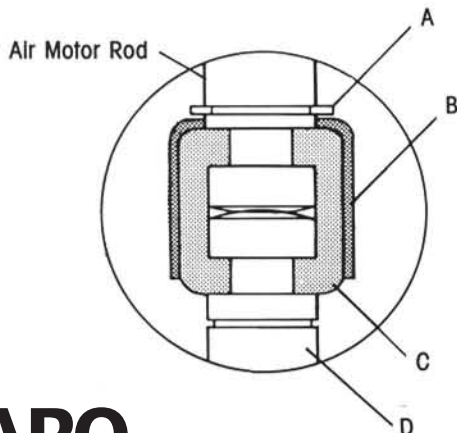

FIGURE 2