

LiftMaster®

Commercial Door Operators

The Chamberlain Group, Inc.
845 Larch Avenue
Elmhurst, Illinois 60126-1196
www.liftmaster.com



SECURITY+® COMMERCIAL DOOR OPENER

Model ATS 2113X 1/2 HP

*For Residential And Light Duty Commercial Use
Install on Sectional Doors Only*

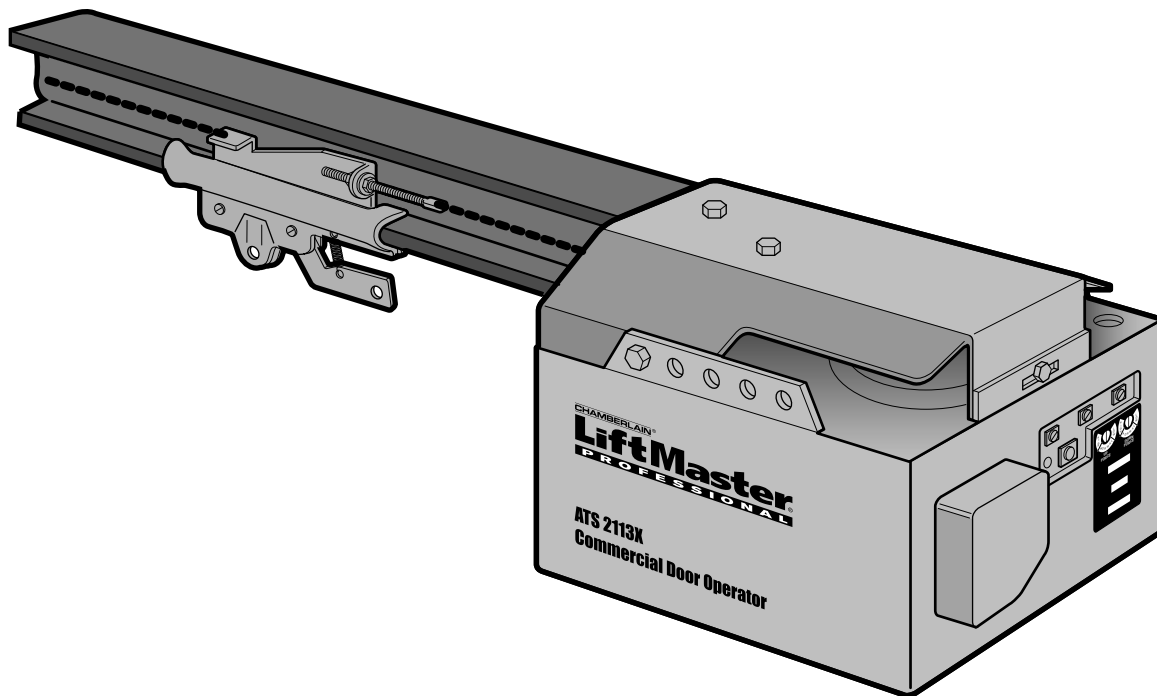

Owner's Manual

- Please read this manual and the enclosed safety materials carefully!
- Fasten the manual near the garage door after installation.
- The door WILL NOT CLOSE unless the Protector System® is connected and properly aligned.
- Periodic checks of the opener are required to ensure safe operation.
- The model number label is located on the front panel of your opener.
- DO NOT exceed 8 complete cycles of door operation per hour.

TABLE OF CONTENTS

Introduction	2-5	Adjustment	20-22
Safety symbol and signal word review	2	Adjust the travel limits	20
Preparing your garage door	3	Adjust the force	21
Tools needed	3	Test the safety reversal system	22
Planning	4	Test the Protector System®	22
Carton inventory	5	Operation	23-25
Hardware inventory	5	Operation safety instructions	23
Assembly	6-7	Using your garage door opener	23
Attach the rail to the motor unit	6	Using the wall-mounted door control	24
Attach the chain to the sprocket and install the rail support bracket	6	To open the door manually	24
Tighten the chain	7	Care of your garage door opener	24
Installation	7-19	Having a problem?	25
Installation safety instructions	7	Programming	26-28
Determine the header bracket location	8	3-Button remote controls (Optional)	26
Install the header bracket	9	To add or change a Keyless Entry PIN (Optional)	27
Attach the rail to the header bracket	10	Multi-Function door control (Optional)	28
Position the opener	11	Repair Parts	29-32
Hang the opener	11	Rail assembly parts	29
Install the door control	12	Installation parts	29
Install the light	13	Motor unit assembly parts	30
Attach the emergency release rope and handle	13	Accessories	31
Electrical requirements	14	Repair Parts and Service	32
Install the Protector System®	15-17	Warranty	32
Fasten the door bracket	18		
Connect the door arm to the trolley	19		

INTRODUCTION

Safety Symbol and Signal Word Review

This garage door opener has been designed and tested to offer safe service provided it is installed, operated, maintained and tested in strict accordance with the instructions and warnings contained in this manual.

WARNING

Mechanical

WARNING

Electrical

CAUTION

When you see these Safety Symbols and Signal Words on the following pages, they will alert you to the possibility of **serious injury or death** if you do not comply with the warnings that accompany them. The hazard may come from something mechanical or from electric shock. Read the warnings carefully.

When you see this Signal Word on the following pages, it will alert you to the possibility of damage to your garage door and/or the garage door opener if you do not comply with the cautionary statements that accompany it. Read them carefully.

Preparing your garage door

Before you begin:

- Disable locks.
- Remove any ropes connected to garage door.
- Complete the following test to make sure your garage door is balanced and is not sticking or binding:
 1. Lift the door about halfway as shown. Release the door. If balanced, it should stay in place, supported entirely by its springs.
 2. Raise and lower the door to see if there is any binding or sticking.

If your door binds, sticks, or is out of balance, call a trained door systems technician.

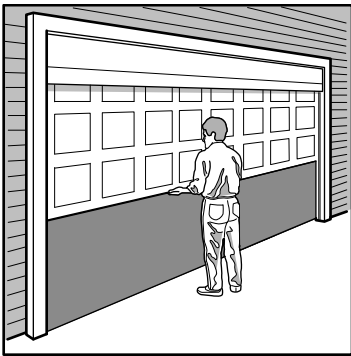

Sectional Door

⚠ WARNING

To prevent possible **SERIOUS INJURY OR DEATH**:

- **ALWAYS** call a trained door systems technician if garage door binds, sticks, or is out of balance. An unbalanced garage door may not reverse when required.
- **NEVER** try to loosen, move or adjust garage door, door springs, cables, pulleys, brackets or their hardware, **ALL** of which are under **EXTREME** tension.
- Disable **ALL** locks and remove **ALL** ropes connected to garage door **BEFORE** installing and operating garage door opener to avoid entanglement.
- This product is for use on sectional garage doors **ONLY**. **SERIOUS INJURY** could result from the use of this product on one piece garage doors.

CAUTION

To prevent damage to garage door and opener:

- **ALWAYS** disable locks **BEFORE** installing and operating the opener.
- **ONLY** operate garage door opener at 120V, 60 Hz to avoid malfunction and damage.

Tools needed

During assembly, installation and adjustment of the opener, instructions will call for hand tools as illustrated below.

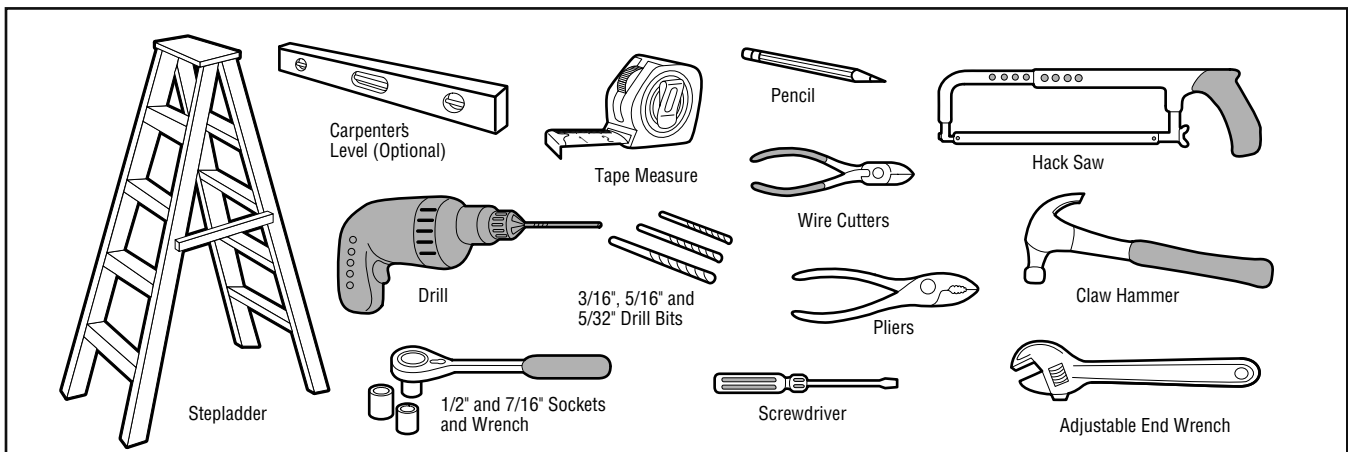

Planning

Identify the type and height of your garage door. Survey your garage area to see if any of the conditions below apply to your installation. Additional materials may be required. You may find it helpful to refer back to this page and the accompanying illustrations as you proceed with the installation of your opener.

! WARNING

Without a properly working safety reversal system, persons (particularly small children) could be **SERIOUSLY INJURED** or **KILLED** by a closing garage door.

- The gap between the bottom of the garage door and the floor **MUST NOT** exceed 1/4" (6 mm). Otherwise, the safety reversal system may not work properly.
- The floor or the garage door **MUST** be repaired to eliminate the gap.

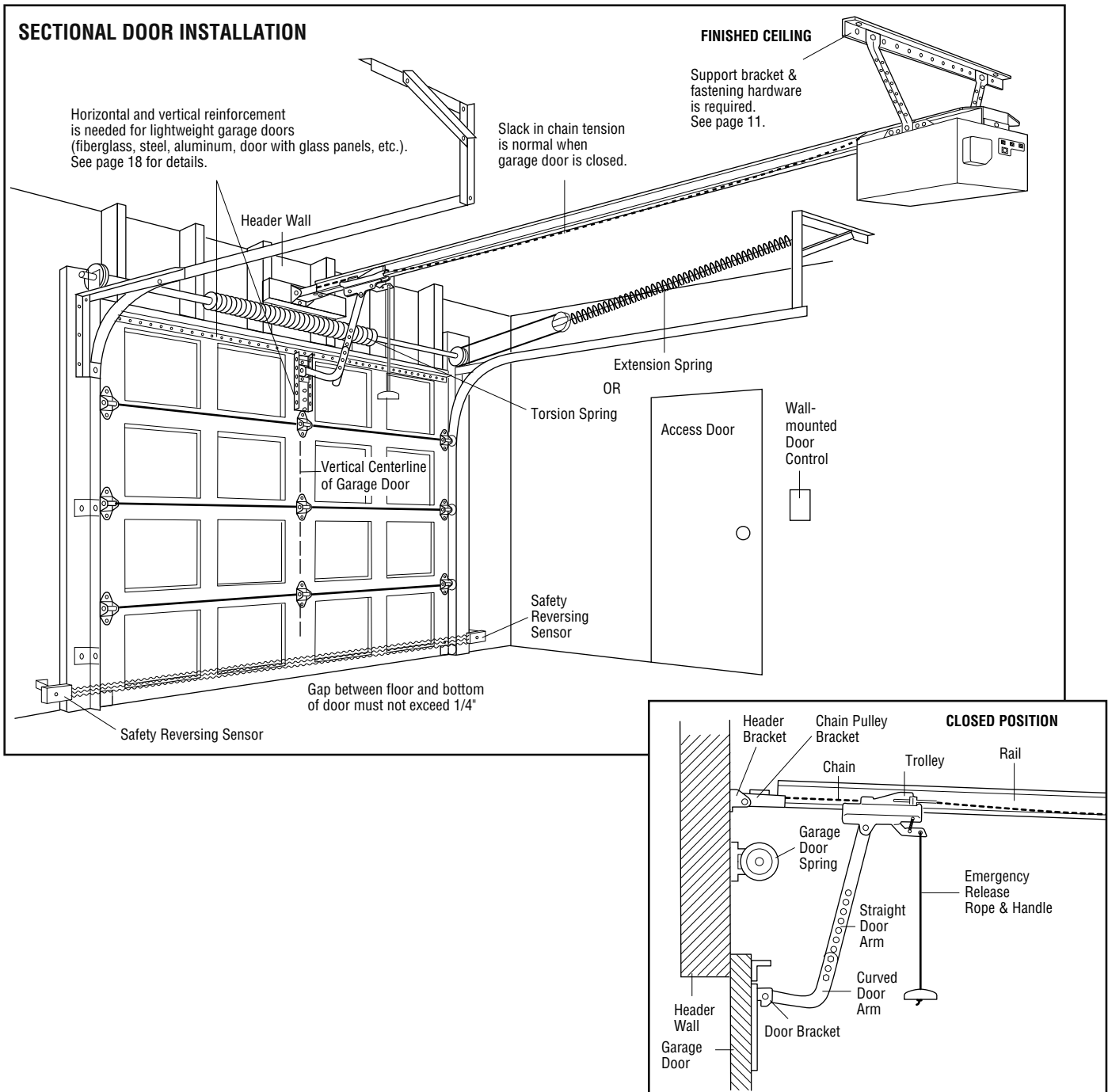

Carton Inventory

Your garage door opener is packaged in two cartons which contain the motor unit and all parts illustrated below. Accessories will depend on the model purchased. If anything is missing, carefully

check the packing material. Parts may be stuck in the foam. Hardware for installation is also listed below.

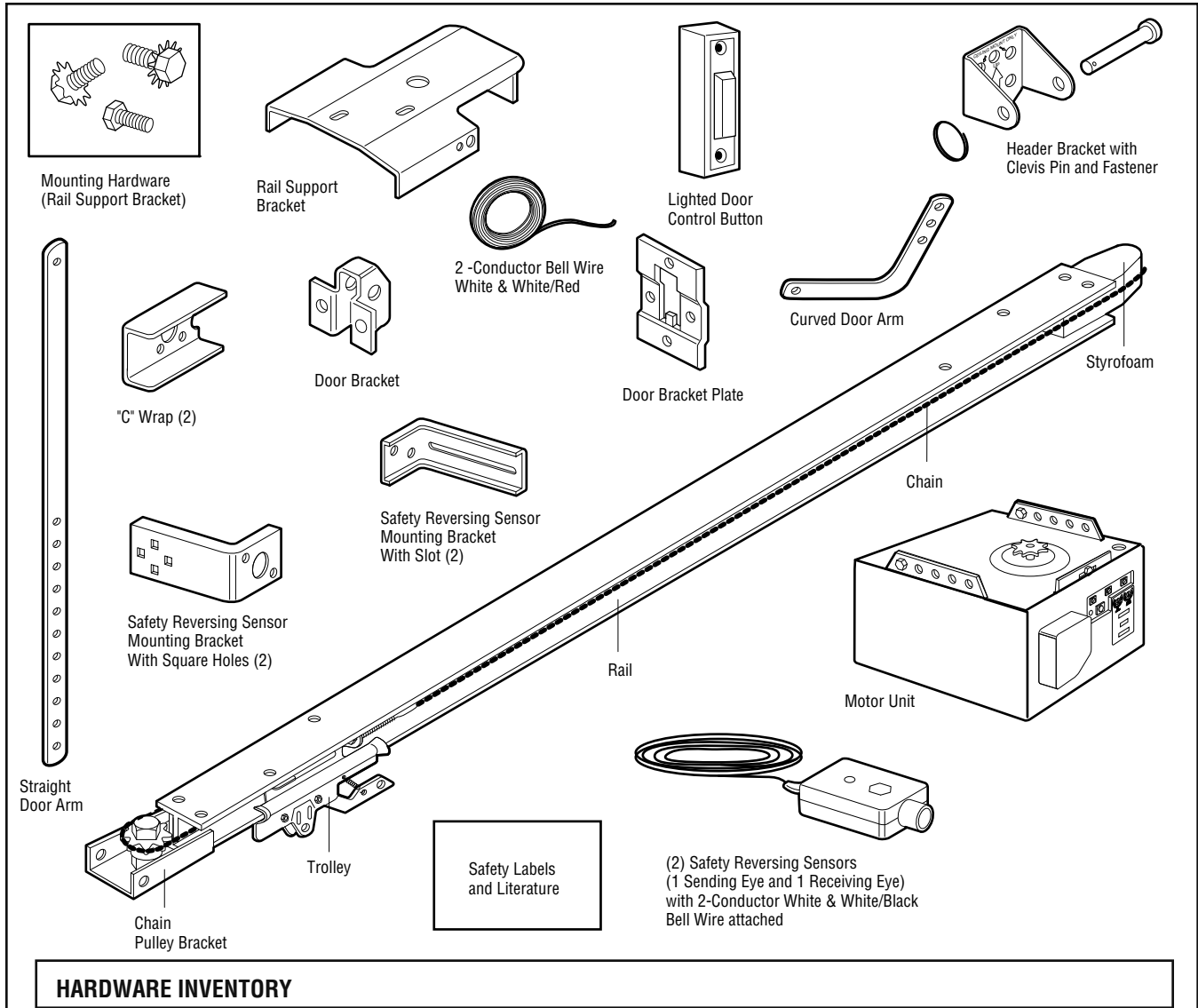

HARDWARE INVENTORY

Assembly Hardware

Washed Bolt, 5/16"-18x1/2" (2)
(Mounted in Opener)
Hex Screw 1/4"-20x5/8" (2)
Lock Washer 1/4"-20x5/8" (2)
Screw #8-32x3/8" (1)
Washed Bolt
5/16"-18x1/2" (2)

Installation Hardware

Hex Screw 5/16"-18x7/8" (4)
Nut 5/16"-18 (4)
Lock Washer 5/16" (4)
Rail Grease
Lag Screw 5/16"-9x1-5/8" (2)
Lag Screw 5/16"-18x1-7/8" (2)-
Screw 6ABx1-1/2" (2)
Handle
Ring Fastener (3)
Self-Tapping Screw 1/4"-14x5/8" (2)
Insulated Staples (10)
Drywall Anchors (2)
Clevis Pin 5/16"x2-3/4" (1)
Clevis Pin 5/16"x1" (2)
Rope

Hardware for Safety Reversing Sensor

Lag Screw 1/4"x1-1/2" (4)
Carriage Bolt 1/4"-20x1/2" (4)
Lock Nut 1/4"-20 (4)
Wing Nut (2)
Hex Screw 1/4"-20x1-1/2" (2)
Screw #10-32x3/8" (4)
Lock Nut #10x32 (4)
Insulated Staples (20)

ASSEMBLY STEP 1

Attach the Rail to the Motor Unit

To avoid installation difficulties, do not run the garage door opener until instructed to do so.

- Place the opener on packing material to protect the cover.
- Remove the (2) 5/16"-18x1/2" washered bolts mounted in the top of the motor unit.
- Position rail at a 45° angle to opener so one hole in rail and motor unit line up.
- Thread one of the washered bolts part way in.

Use only these bolts! Use of any other bolts will cause serious damage to door opener.

- Align rail over sprocket. Cut tape from rail.

ASSEMBLY STEP 2

Attach the Chain to the Sprocket and Install the Rail Support Bracket

- Guide the chain over chain spreader and opener sprocket. If necessary, loosen the outer nut on the trolley to obtain more chain slack. Insert the second washered bolt. **Use only the bolts previously removed from opener.**
- Tighten both bolts securely through the rail into the opener as shown.
- Position the rail support bracket on the opener.
- Attach the bracket to the rail with 1/4"-20x5/8" hex bolts and lock washers. **DO NOT overtighten.**
- Attach the bracket to the opener by inserting a 5/16"-18x1/2" washered bolt through a hole in each side flange and a matching hole in the bracket. Complete the connection by inserting the #8-32x3/8" screw through the back flange and the hole in rail support.

Proceed to Assembly Step 3.

CAUTION

To avoid **SERIOUS** damage to opener, **ONLY** use bolts/fasteners mounted in top of motor unit.

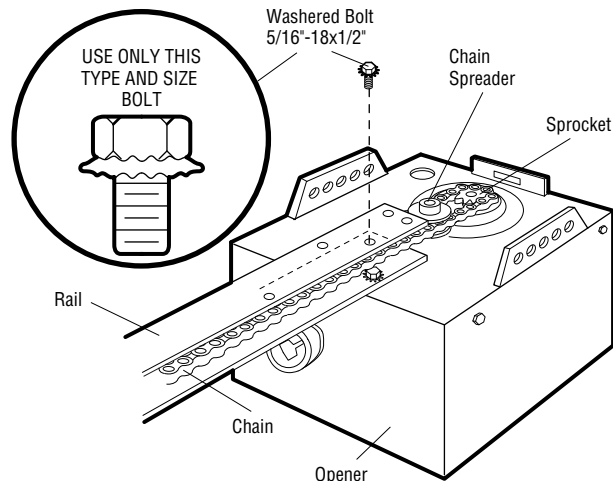

WARNING

To avoid possible **SERIOUS INJURY** to fingers from moving garage door opener:

- **ALWAYS** keep hand clear of sprocket while operating opener.
- Securely attach rail support bracket **BEFORE** operating.

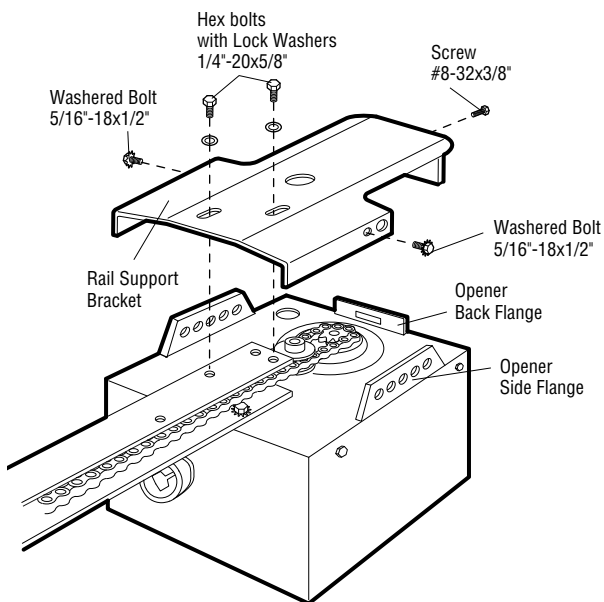

HARDWARE SHOWN ACTUAL SIZE

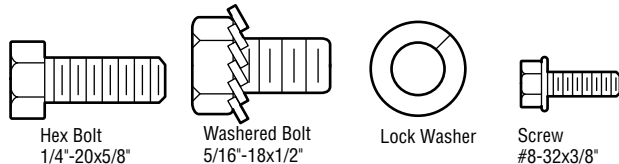

ASSEMBLY STEP 3

Tighten the Chain

- Spin the inner nut and lock washer down the threaded shaft, away from the trolley.
- To tighten the chain, turn outer nut in the direction shown. **As you turn the nut, keep the chain from twisting.**
- When the chain is approximately 1/2" (1.27 cm) above the base of the rail at its midpoint, re-tighten the inner nut to secure the adjustment.

Sprocket noise can result if chain is either too loose or too tight.

When installation is complete, you may notice some chain droop with the door closed. This is normal. If the chain returns to the position shown when the door is open, do not re-adjust the chain.

NOTE: During future maintenance, ALWAYS pull the emergency release handle to disconnect trolley before adjusting chain.

You have now finished assembling your garage door opener. Please read the following warnings before proceeding to the installation section.

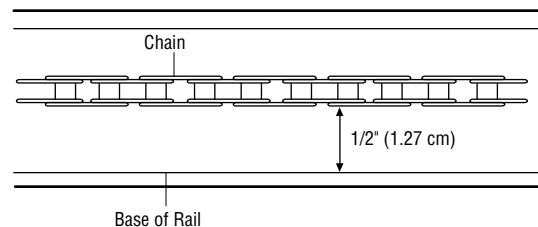
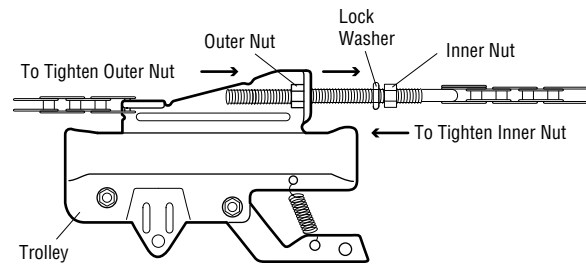

INSTALLATION

IMPORTANT INSTALLATION INSTRUCTIONS

WARNING

To reduce the risk of SEVERE INJURY or DEATH:

1. READ AND FOLLOW ALL INSTALLATION WARNINGS AND INSTRUCTIONS.
2. Install garage door opener only on properly balanced and lubricated garage door. An improperly balanced door may not reverse when required and could result in SEVERE INJURY or DEATH.
3. ALL repairs to cables, spring assemblies and other hardware MUST be made by a trained door systems technician BEFORE installing opener.
4. Disable ALL locks and remove ALL ropes connected to garage door BEFORE installing opener to avoid entanglement.
5. Install garage door opener 7 feet (2.13 m) or more above floor.
6. Mount emergency release handle 6 feet (1.83 m) above floor.
7. NEVER connect garage door opener to power source until instructed to do so.
8. NEVER wear watches, rings or loose clothing while installing or servicing opener. They could be caught in garage door or opener mechanisms.
9. Install wall-mounted garage door control:
 - within sight of the garage door.
 - out of reach of children at minimum height of 5 feet (1.5 m).
 - away from ALL moving parts of the door.
10. Install the entrapment warning placard next to the control station in a prominent location.
11. Place manual release/safety reverse test label in plain view on inside of garage door.
12. Upon completion of installation, test safety reversal system. Door MUST reverse on contact with a 1-1/2" (3.8 cm) high object (or a 2x4 laid flat) on the floor.

INSTALLATION STEP 1

Determine the Header Bracket Location

WARNING

To prevent possible SERIOUS INJURY or DEATH:

- Header bracket **MUST** be RIGIDLY fastened to structural support on header wall or ceiling, otherwise garage door might not reverse when required. **DO NOT** install header bracket over drywall.
- Concrete anchors **MUST** be used if mounting header bracket or 2x4 into masonry.
- **NEVER** try to loosen, move or adjust garage door, springs, cables, pulleys, brackets, or their hardware, **ALL** of which are under **EXTREME** tension.
- **ALWAYS** call a trained door systems technician if garage door binds, sticks, or is out of balance. An unbalanced garage door might not reverse when required.

1. Close the door and mark the inside vertical centerline of the garage door.
2. Extend the line onto the header wall above the door.

You can fasten the header bracket within 4 feet (1.22 m) of the left or right of the door center only if a torsion spring or center bearing plate is in the way; or you can attach it to the ceiling (see page 9) when clearance is minimal. (It may be mounted on the wall upside down if necessary, to gain approximately 1/2" (1.27 cm).)

If you need to install the header bracket on a 2x4 (on wall or ceiling), use lag screws (not provided) to securely fasten the 2x4 to structural supports as shown here and on page 9.

3. Open your door to the highest point of travel as shown. Draw an intersecting horizontal line on the header wall 2" (5 cm) above the high point. This height will provide travel clearance for the top edge of the door.

Proceed to Step 2, page 9.

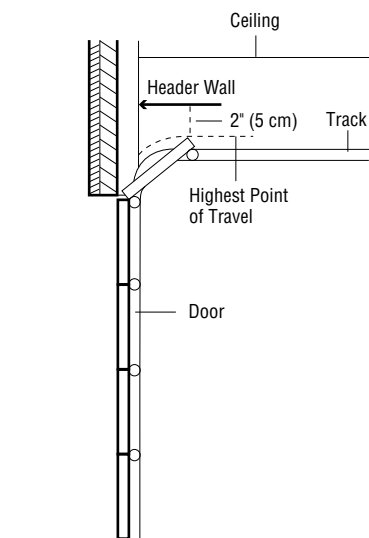
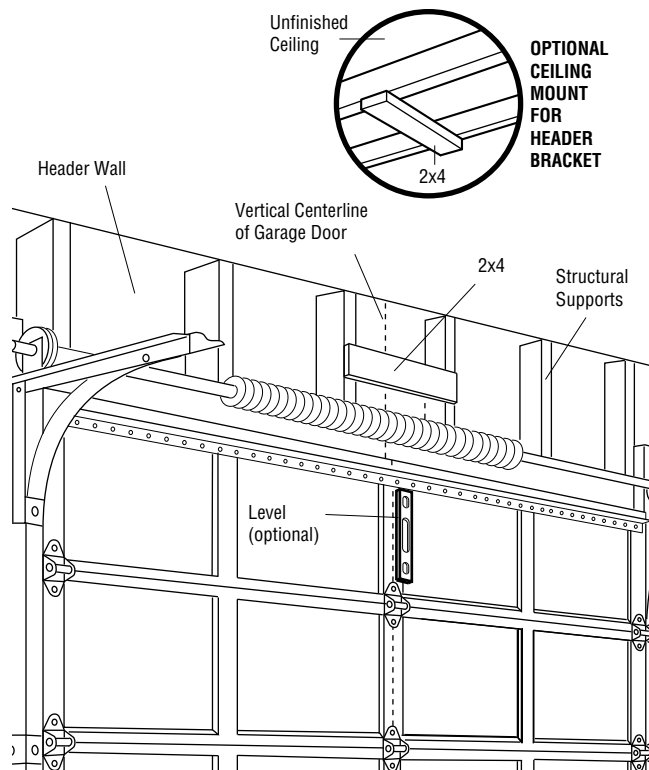

SECTIONAL DOOR WITH CURVED TRACK

INSTALLATION STEP 2

Install the Header Bracket

You can attach the header bracket either to the wall above the garage door, or to the ceiling. Follow the instructions which will work best for your particular requirements. **DO NOT install the header bracket over drywall. If installing into masonry, use concrete anchors (not provided).**

WALL HEADER BRACKET INSTALLATION

- Center the bracket on the vertical centerline with the bottom edge of the bracket on the horizontal line as shown (with the arrow pointing toward the ceiling).
- Mark the vertical set of bracket holes (do not use the holes designated for ceiling mount). Drill 3/16" pilot holes and fasten the bracket securely to a structural support with the hardware provided.

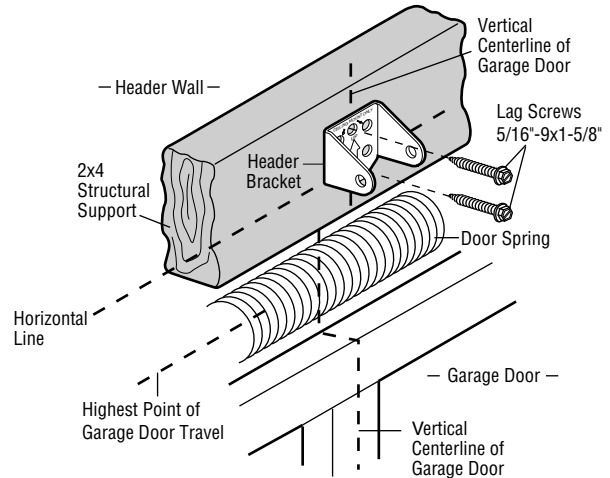
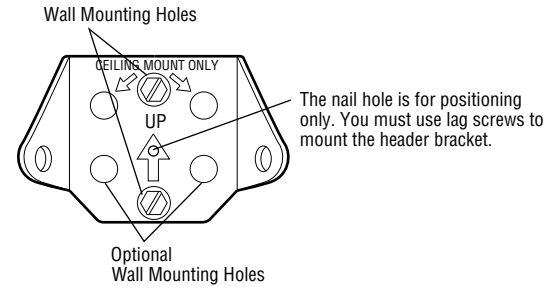
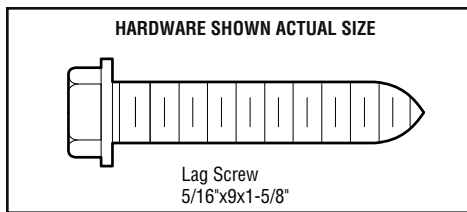

CEILING HEADER BRACKET INSTALLATION

- Extend the vertical centerline onto the ceiling as shown.
- Center the bracket on the vertical mark, no more than 6" (15 cm) from the wall. Make sure the arrow is pointing toward the wall. The bracket can be mounted flush against the ceiling when clearance is minimal.
- Mark the side holes. Drill 3/16" pilot holes and fasten bracket securely to a structural support with the hardware provided.

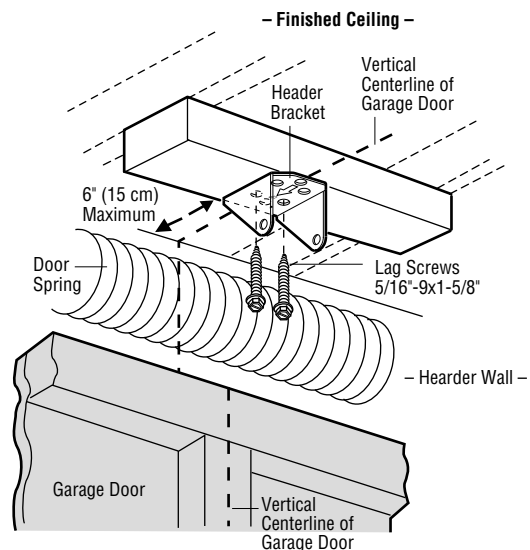
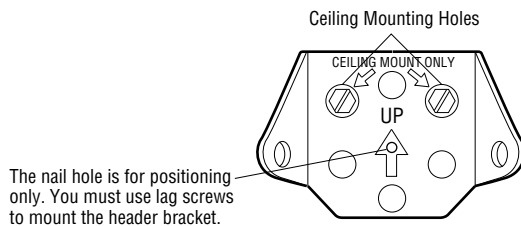

INSTALLATION STEP 3

Attach the Rail to the Header Bracket

- Position the opener on the garage floor below the header bracket. Use packing material as a protective base. **NOTE:** If the door spring is in the way you'll need help. Have someone hold the opener securely on a temporary support to allow the rail to clear the spring.
- Position the chain pulley bracket against the header bracket.
- Align the bracket holes and join with a clevis pin as shown.
- Insert a ring fastener to secure.

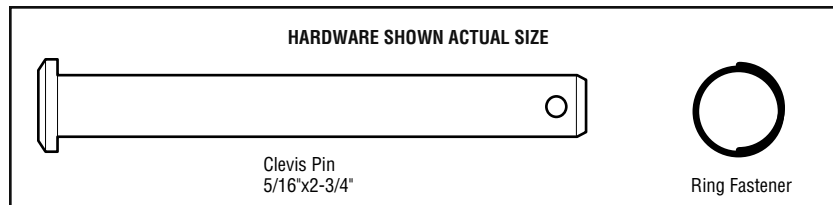
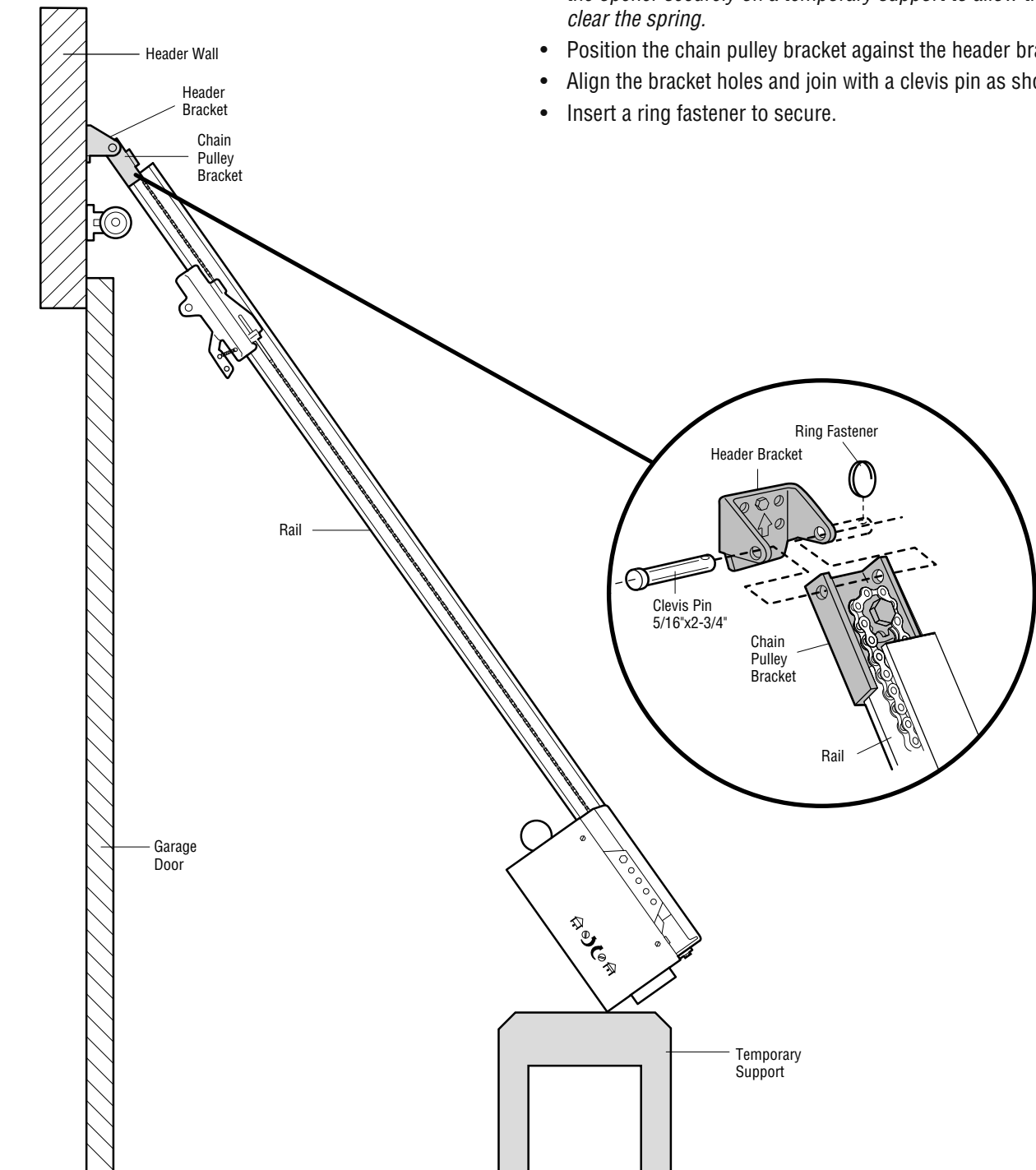

INSTALLATION STEP 4

Position the Opener

SECTIONAL DOOR ONLY

A 2x4 laid flat is convenient for setting an ideal door-to-rail distance.

- Raise the opener onto a stepladder. You will need help at this point if the ladder is not tall enough.
- Open the door all the way and place a 2x4 laid flat on the top section beneath the rail.

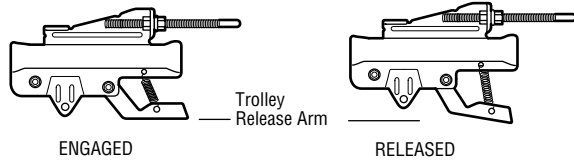

INSTALLATION STEP 5

Hang the Opener

Two representative installations are shown. Yours may be different. Hanging brackets should be angled (Figure 1) to provide rigid support. On finished ceilings (Figure 2), attach a sturdy metal bracket to structural supports before installing the opener. This bracket and fastening hardware are not provided.

1. Measure the distance from each side of the motor unit to the structural support.
2. Cut both pieces of the hanging bracket to required lengths.
3. Drill 3/16" pilot holes in the structural supports.
4. Attach one end of each bracket to a support with 5/16"-18x1-7/8" lag screws.
5. Fasten the opener to the hanging brackets with 5/16"-18x7/8" hex bolts, lock washers and nuts.
6. Check to make sure the rail is centered over the door (or in line with the header bracket if the bracket is not centered above the door).
7. Remove the 2x4. Operate the door manually. If the door hits the rail, raise the header bracket.
8. Grease the top and underside of the rail surface where the trolley slides with rail grease.

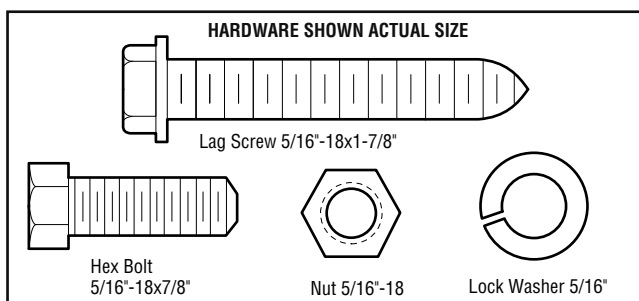

CAUTION

To prevent damage to garage door, rest garage door opener rail on 2x4 placed on top section of door.

- If the top section or panel hits the trolley when you raise the door, pull down on the trolley release arm to disconnect inner and outer sections. Slide the outer trolley toward the motor unit. The trolley can remain disconnected until Installation Step 12 is completed.

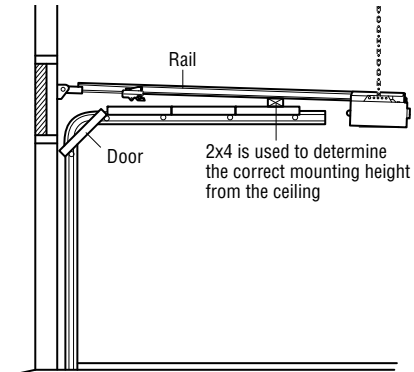

WARNING

To avoid possible **SERIOUS INJURY** from a falling garage door opener, fasten it **SECURELY** to structural supports of the garage. Concrete anchors **MUST** be used if installing **ANY** brackets into masonry.

Figure 1

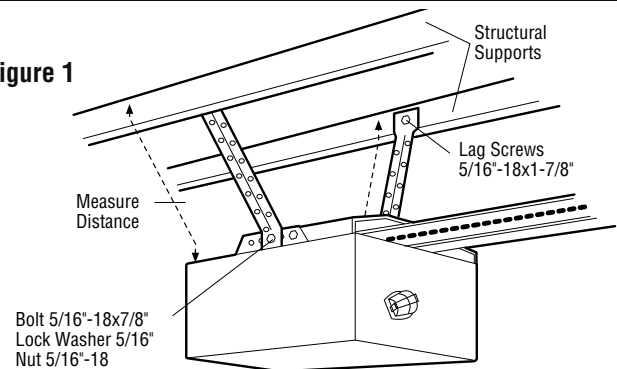
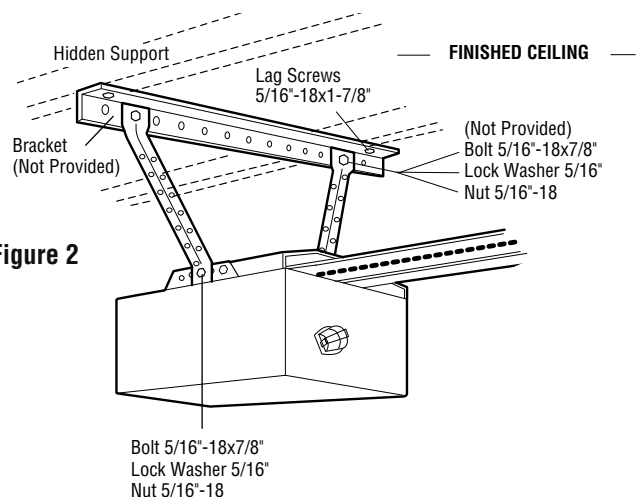

Figure 2



INSTALLATION STEP 6

Install the Door Control

Locate the door control within sight of the door at a minimum height of 5 feet (1.5 m) where small children cannot reach, and away from all moving parts of the door and door hardware.

- Strip 7/16" (11 mm) of insulation from one end of the bell wire. Connect it to the two screw terminals on the back of the door control by color: white wire to 2 and white/red wire to 1.
- Fasten the Lighted Door Control Button securely with 6ABx1-1/2" screws. If installing into drywall, drill 5/32" holes and use the anchors provided.
- Run the bell wire up the wall and across the ceiling to the opener. Use insulated staples to secure the wire in several places. Be careful not to pierce the wire with a staple, creating a short or open circuit.
- Receiver terminal screws and the antenna are located on the back panel of the motor unit. Position the antenna wire as shown.
- Connect the bell wire by color to the opener terminal screws: white to 2 and white/red to 1.
- Use tacks or staples to permanently attach the entrapment warning label to the wall near the door control, and the manual release/safety reverse test in a prominent location on the inside of the garage door.

NOTE: DO NOT connect the power and operate the opener at this time. The trolley will travel to the full open position, but will not return to the close position until the sensor beam is connected and properly aligned. See Safety Reversing Sensor instructions beginning on page 15.

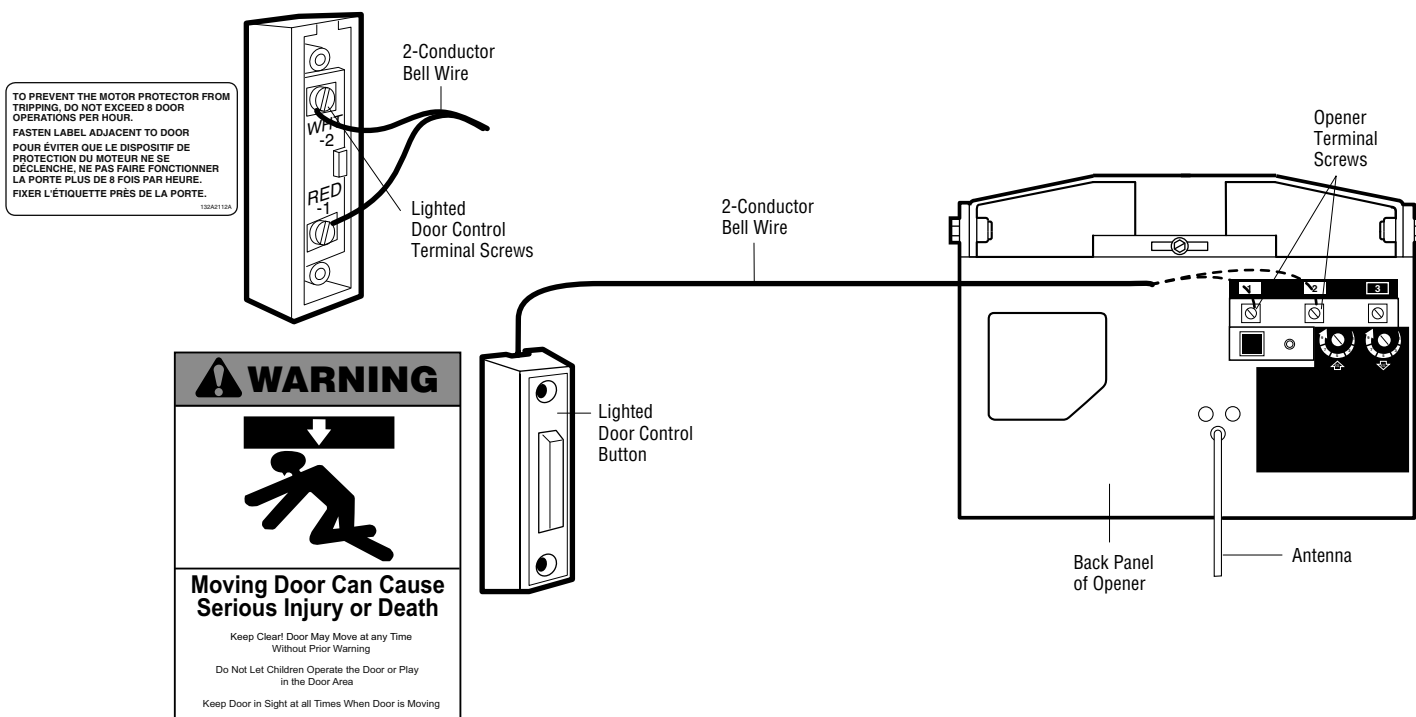

⚠️ WARNING

To prevent possible SERIOUS INJURY or DEATH from electrocution:

- Be sure power is not connected BEFORE installing door control.
- Connect ONLY to 24 VOLT low voltage wires.

To prevent possible SERIOUS INJURY or DEATH from a closing garage door:

- Install door control within sight of garage door, out of reach of children at a minimum height of 5 feet (1.5 m), and away from ALL moving parts of door.
- NEVER permit children to operate or play with door control push buttons or remote control transmitters.
- Activate door ONLY when it can be seen clearly, is properly adjusted, and there are no obstructions to door travel.
- ALWAYS keep garage door in sight until completely closed. NEVER permit anyone to cross path of closing garage door.

HARDWARE SHOWN ACTUAL SIZE

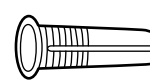
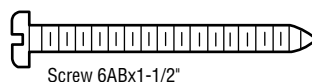

Outside Keylock Accessory Connections

To opener terminal screws: White to 2 and white/red to 1.

INSTALLATION STEP 7

Install the Light

- Install a 75 watt maximum light bulb in the socket. The light will turn ON and remain lit for approximately 4-1/2 minutes when power is connected. Then the light will turn OFF.
- If the bulb burns out prematurely due to vibration, replace with a "Garage Door Opener" bulb.

NOTE: Use only standard light bulbs. The use of short neck or specialty light bulbs may overheat the endpanel or light socket.

CAUTION	
To prevent possible OVERHEATING of the endpanel or light socket,	
<ul style="list-style-type: none">• DO NOT use short neck or specialty light bulbs.• DO NOT use halogen bulbs. Use ONLY incandescent.	

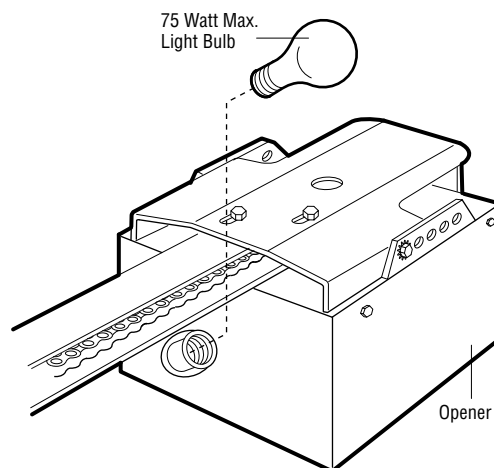

INSTALLATION STEP 8

Attach the Emergency Release Rope and Handle

- Thread one end of the rope through the hole in the top of the red handle so "NOTICE" reads right side up as shown. Secure with an overhand knot at least 1" (2.54 cm) from the end of the rope to prevent slipping.
- Thread the other end of the rope through the hole in the release arm of the outer trolley.
- Adjust rope length so the handle is 6 feet (1.83 m) above the floor. Secure with an overhand knot.

NOTE: If it is necessary to cut the rope, heat seal the cut end with a match or lighter to prevent unraveling.

WARNING	
To prevent possible SERIOUS INJURY or DEATH from a falling garage door:	
<ul style="list-style-type: none">• If possible, use emergency release handle to disengage trolley ONLY when garage door is CLOSED. Weak or broken springs or unbalanced door could result in an open door falling rapidly and/or unexpectedly.• NEVER use emergency release handle unless garage doorway is clear of persons and obstructions.• NEVER use handle to pull door open or closed. If rope knot becomes untied, you could fall.	

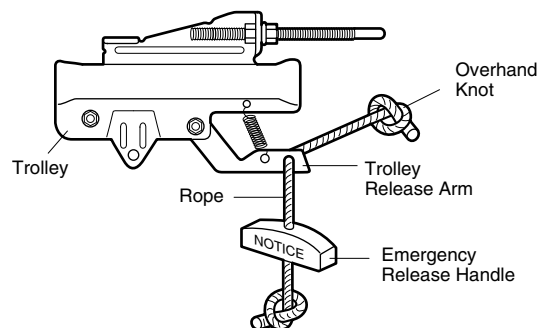

INSTALLATION STEP 9

Electrical Requirements

To avoid installation difficulties, do not run the opener at this time.

To reduce the risk of electric shock, your garage door opener has a grounding type plug with a third grounding pin. This plug will only fit into a grounding type outlet. If the plug doesn't fit into the outlet you have, contact a qualified electrician to install the proper outlet.

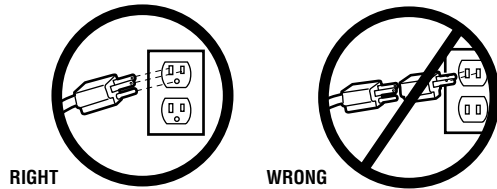

If permanent wiring is required by your local code, refer to the following procedure.

To make a permanent connection through the 7/8" hole in the top of the motor unit:

- Remove the motor unit cover screws and set the cover aside.
- Remove the attached 3-prong cord.
- Connect the black (line) wire to the screw on the brass terminal; the white (neutral) wire to the screw on the silver terminal; and the ground wire to the green ground screw. **The opener must be grounded.**
- Reinstall the cover.

To avoid installation difficulties, do not run the opener at this time.

WARNING

To prevent possible SERIOUS INJURY or DEATH from electrocution or fire:

- Be sure power is not connected to the opener, and disconnect power to circuit BEFORE removing cover to establish permanent wiring connection.
- Garage door installation and wiring MUST be in compliance with ALL local electrical and building codes.
- NEVER use an extension cord, 2-wire adapter, or change plug in ANY way to make it fit outlet. Be sure the opener is grounded.

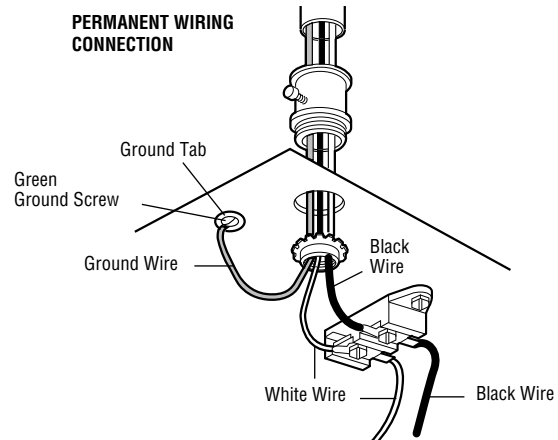

INSTALLATION STEP 10

Install The Protector System®

The safety reversing sensor must be connected and aligned correctly before the garage door opener will move in the down direction.

IMPORTANT INFORMATION ABOUT THE SAFETY REVERSING SENSOR

When properly connected and aligned, the sensor will detect an obstacle in the path of its electronic beam. The sending eye transmits an invisible light beam to the receiving eye. If an obstruction breaks the light beam while the door is closing, the door will stop and reverse to full open position, and the opener lights will flash 10 times.

The units must be installed inside the garage so that the sending and receiving eyes face each other across the door, no more than 6" (15 cm) above the floor. Either can be installed on the left or right of the door as long as the sun never shines directly into the receiving eye lens.

⚠ WARNING

Be sure power is not connected to the garage door opener BEFORE installing the safety reversing sensor.

To prevent SERIOUS INJURY or DEATH from a closing garage door:

- Correctly connect and align the safety reversing sensor. This required safety device MUST NOT be disabled.
- Install the safety reversing sensor so beam is NO HIGHER than 6" (15 cm) above garage floor.

If it is necessary to mount the units on the wall, the brackets must be securely fastened to a solid surface such as the wall framing. If installing in masonry construction, add a piece of wood at each location to avoid drilling extra holes in masonry if repositioning is necessary.

The invisible light beam path must be unobstructed. No part of the garage door (or door tracks, springs, hinges, rollers or other hardware) may interrupt the beam while the door is closing.

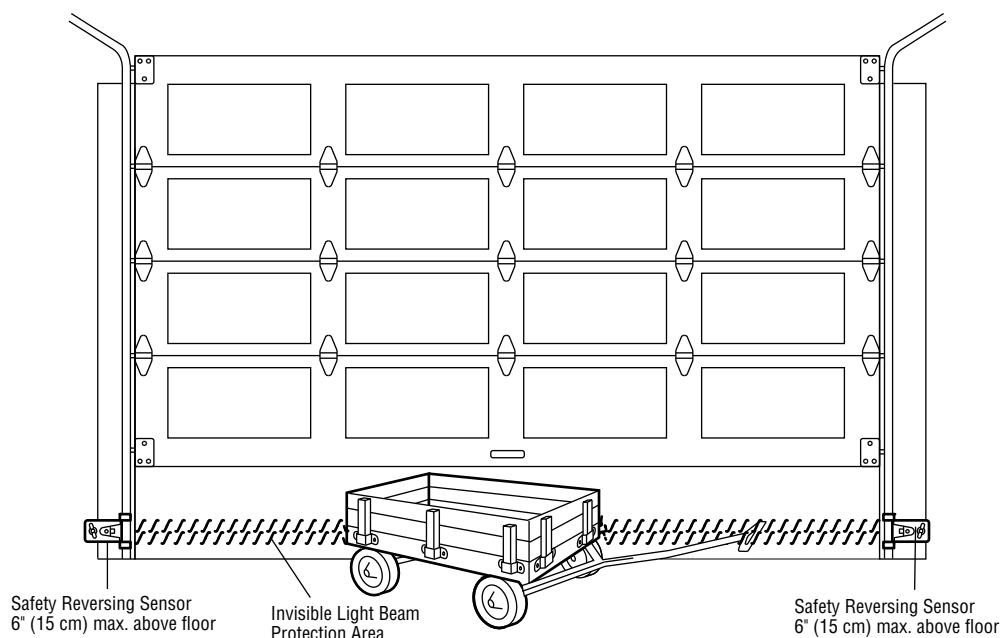

Facing the door from inside the garage

INSTALLING THE BRACKETS

Figure 1, 2 and 3 show recommended assembly of bracket(s) and "C" wrap based on the *wall* installation of the sensors on each side of the garage door as shown on page 15, or on the *garage door tracks* themselves.

Figure 4 and 5 are variations which may fit your installation requirements better. **Make sure the wraps and brackets are aligned so the sensors will face each other across the garage door.**

Garage Wall or Door Track Installation

1. Fasten the "C" wraps to the mounting brackets having square holes, using the hardware shown in Figure 1.

Garage Wall Installation

2. Connect each assembly to a slotted bracket, using the hardware shown on Figure 2. **Note alignment of brackets for left and right sides of door.**
3. Finger tighten the lock nuts.
4. Use bracket mounting holes as a template to locate and drill (2) 3/16" diameter pilot holes on both sides of the garage door, 4"-6" (10-15 cm) above the floor **but not exceeding 6" (15 cm)** (see warning on page 15).
5. Attach bracket assembly with 1/4"x1-1/2" lag screws as shown in Figure 2.
6. Adjust right and left bracket assemblies to the same distance out from mounting surface. Make sure all door hardware obstructions are cleared. Tighten the nuts securely.

Garage Door Track Installation

Discard slotted bracket. Drill 3/8" holes in each track and fasten securely with hardware as shown in Figure 3.

Figure 1 Garage WALL or DOOR Track Installation



Figure 2 Garage WALL Installation

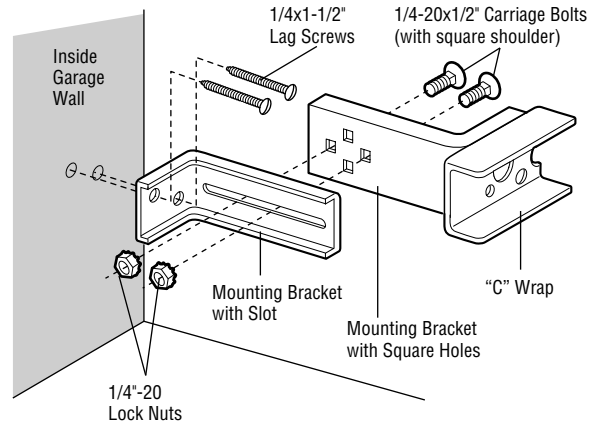

Figure 3 Garage DOOR Track Installation

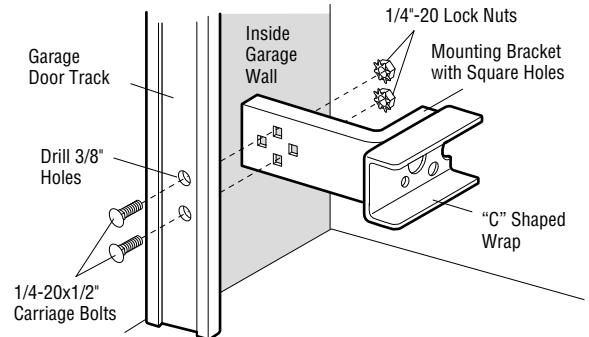

Figure 4 Alternate Wall Mount

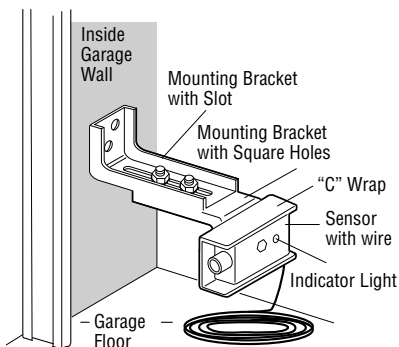
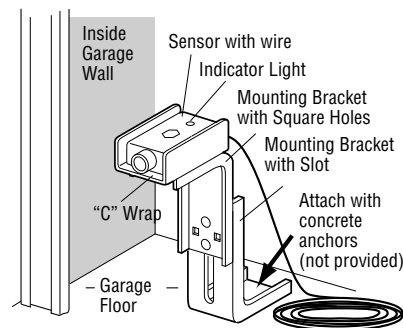
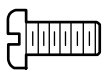

Figure 5 Alternate Floor Mount



HARDWARE SHOWN ACTUAL SIZE



Screw
#10-32x3/8"



Lock Nut
#10x32

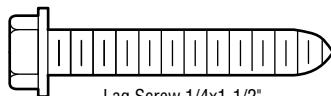

Lag Screw 1/4x1-1/2"

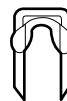

Staples

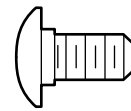

Carriage Bolts
1/4-20x1/2"

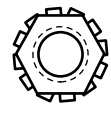

Lock Nut
1/4-20

MOUNTING AND WIRING THE SAFETY SENSORS

- Center each sensor unit in a “C” wrap with lenses pointing toward each other across the door (see Figure 6).
- Secure sensors with the hardware shown. Finger tighten the wing nut on the *receiving eye* to allow for final adjustment. Securely tighten the *sending eye* wing nut.
- Run the wires from both sensors to the opener (see Figure 7). Use insulated staples to secure the wire to wall and ceiling.
- Strip 1/4" (6 mm) of insulation from each set of wires. Separate white and white/black wires sufficiently to connect to the opener terminal screws: white to 2 and white/black to 3.

ALIGNING THE SAFETY SENSORS

- Plug in the opener. The indicator lights in both the *sending* and *receiving eyes* will *glow steadily* if wiring connections and alignment are correct.

The *sending eye* indicator light will glow regardless of alignment or obstruction. If the indicator light in the *receiving eye* is off, dim, or flickering (and the invisible light beam path is not obstructed), alignment is required.

- Loosen the *sending eye* wing nut and readjust, aiming directly at the *receiving eye*. Lock in place.
- Loosen the *receiving eye* wing nut and adjust sensor until it receives the sender's beam. When the green indicator light glows steadily, tighten the wing nut.

Figure 6

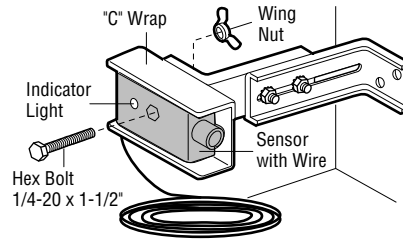

TROUBLESHOOTING THE SAFETY SENSORS

1. If the *sending eye* indicator light does not glow steadily after installation, check for:
 - Electric power to the opener.
 - A short in the white or white/black wires. These can occur at staples, or at opener connections.
 - Incorrect wiring between sensors and opener.
 - A broken wire.
2. If the *sending eye* indicator light glows steadily but the *receiving eye* indicator light doesn't:
 - Check alignment.
 - Check for an open wire to the *receiving eye*.
3. If the *receiving eye* indicator light is dim, realign either sensor.

NOTE: When the invisible beam path is obstructed or misaligned while the door is closing, the door will reverse. If the door is already open, it will not close. The opener lights will blink 10 times. (If bulbs are not installed, 10 clicks can be heard.) See page 15.

Figure 7

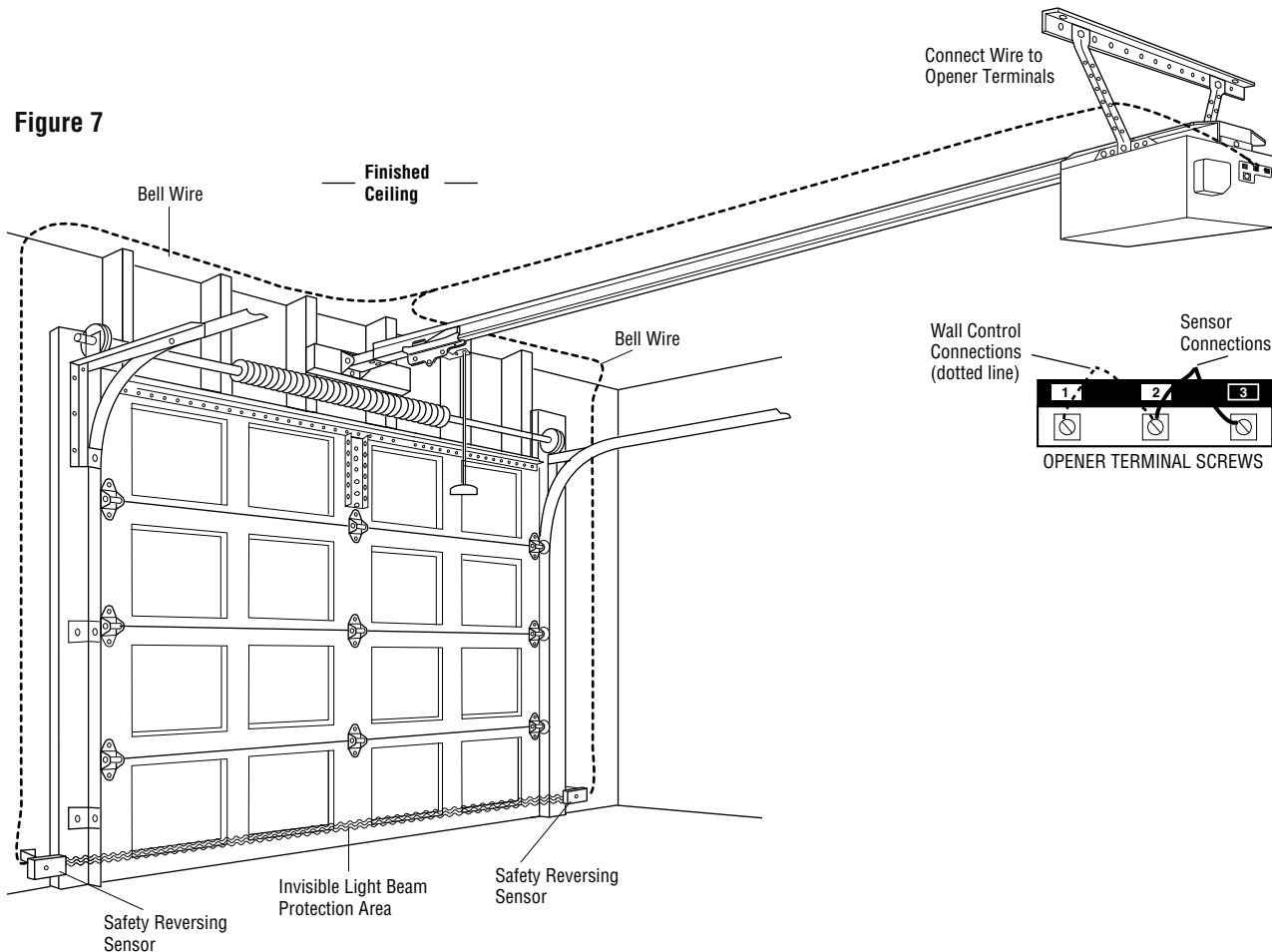

INSTALLATION STEP 11

Fasten the Door Bracket

A horizontal brace should be long enough to be secured to 2 vertical supports. A vertical brace should cover the height of the top panel.

The illustration shows one piece of angle iron as the horizontal brace. For the vertical brace, 2 pieces of angle iron are used to create a "U"-shaped support. The best solution is to check with your garage door manufacturer for an opener installation door reinforcement kit.

- Center the door bracket on the previously marked vertical guideline used for the header bracket installation.
- Position the bracket on the face of the door within the following limits:
 - A) The top edge of the bracket 2"-4" (5-10 cm) below the top edge of the door.
 - B) The top edge of the bracket directly below any structural support across the top of the door.
- Mark and drill 5/16" left and right fastening holes. Secure the bracket as shown in Figure 1 if there is vertical reinforcement.

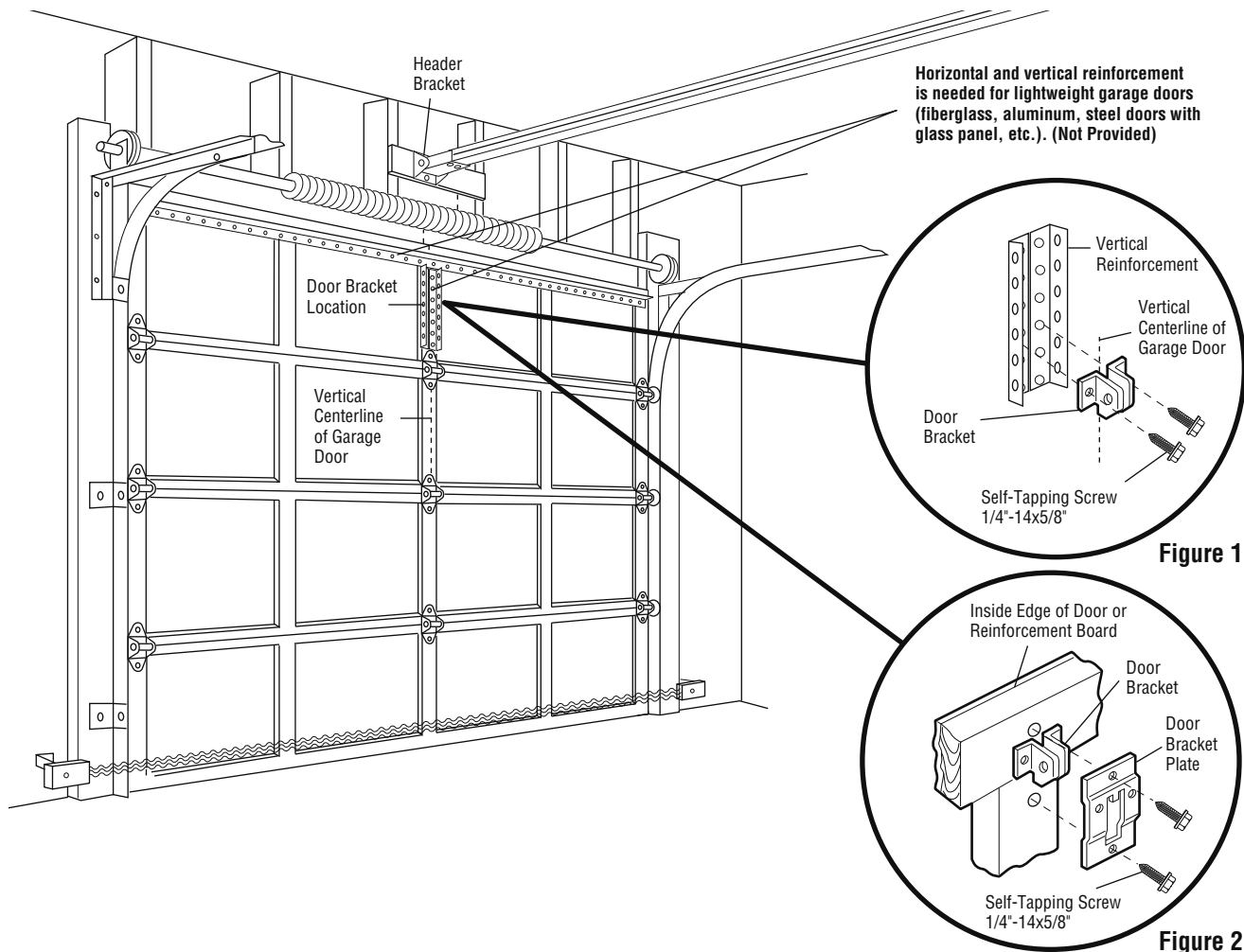

CAUTION

Fiberglass, aluminum or lightweight steel garage doors **WILL REQUIRE** reinforcement BEFORE installation of door bracket. Contact your door manufacturer for reinforcement kit.

If your installation doesn't require vertical reinforcement but does need top and bottom fastening holes for the door bracket, fasten as shown in Figure 2.

HARDWARE SHOWN ACTUAL SIZE

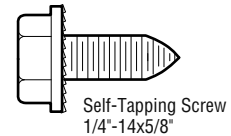

INSTALLATION STEP 12

Connect Door Arm to Trolley

SECTIONAL DOORS ONLY

- Make sure garage door is fully closed. Pull the emergency release handle to disconnect the outer trolley from the inner trolley. Slide the outer trolley back (away from the door) about 2" (5 cm) as shown in Figures 1, 2 and 3.

• **Figure 1:**

- Fasten straight door arm section to outer trolley with the 5/16"x1" clevis pin. Secure the connection with a ring fastener.
- Fasten curved section to the door bracket in the same way, using the 5/16"x1" clevis pin.

• **Figure 2:**

- Bring arm sections together. Find two pairs of holes that line up and join sections. Select holes as far apart as possible to increase door arm rigidity.

• **Figure 3, Hole alignment alternative:**

- If holes in curved arm are above holes in straight arm, disconnect straight arm. Cut about 6" (15 cm) from the solid end. Reconnect to trolley with cut end down as shown.
 - Bring arm sections together.
 - Find two pairs of holes that line up and join with bolts, lock washers and nuts.
- Proceed to Adjustment Step 1, page 20. Trolley will re-engage automatically when opener is operated.

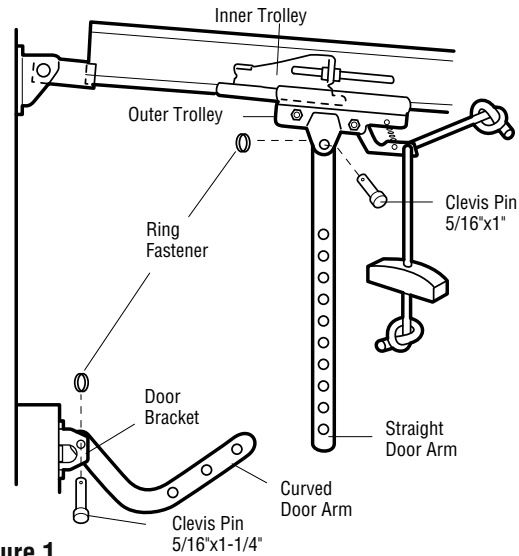

Figure 1

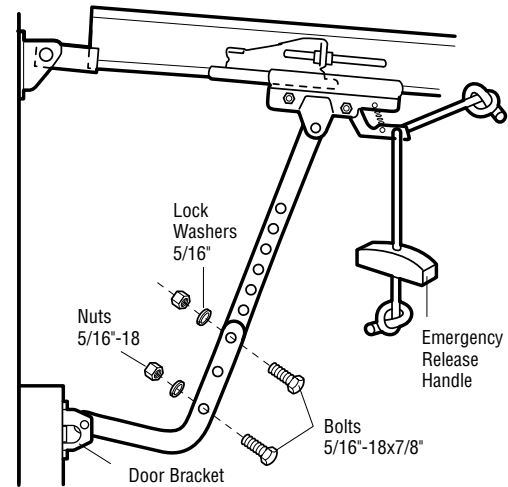

Figure 2

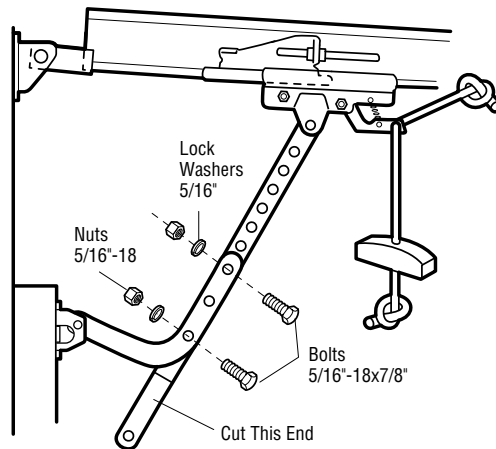
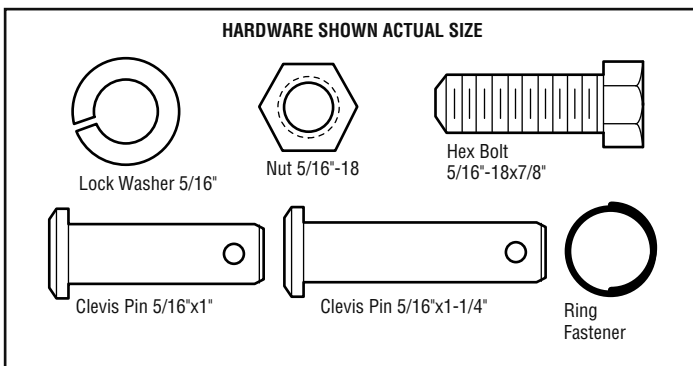

Figure 3



ADJUSTMENT STEP 1

Adjust the UP and DOWN Travel Limits

Limit adjustment settings regulate the points at which the door will stop when moving up or down.

To operate the opener, press the Door Control push bar. Run the opener through a complete travel cycle.

- Does the door open and close completely?
- Does the door stay closed and not reverse unintentionally when fully closed?

If your door passes both of these tests, no limit adjustments are necessary unless the reversing test fails (Adjustment Step 3, page 22).

Adjustment procedures are outlined below. Read the procedures carefully before proceeding to Adjustment Step 2. Use a screwdriver to make limit adjustments. **Run the opener through a complete travel cycle after each adjustment.**

NOTE: Repeated operation of the opener during adjustment procedures may cause the motor to overheat and shut off. Simply wait 15 minutes and try again.

NOTE: If anything interferes with the door's upward travel, it will stop. If anything interferes with the door's downward travel (including binding or unbalanced doors), it will reverse.

HOW AND WHEN TO ADJUST THE LIMITS

- **If the door does not open completely but opens at least 5 feet (1.5 m):**

Increase up travel. Turn the UP limit adjustment screw clockwise. One turn equals 2" (5 cm) of travel.

NOTE: To prevent the trolley from hitting the cover protection bolt, keep a minimum distance of 2-4" (5-10 cm) between the trolley and the bolt.

- **If door does not open at least 5 feet (1.5 m):**

Adjust the UP (open) force as explained in Adjustment Step 2.

- **If the door does not close completely:**

Increase down travel. Turn the down limit adjustment screw counterclockwise. One turn equals 2" (5 cm) of travel.

If door still won't close completely and the trolley bumps into the pulley bracket (page 4), try lengthening the door arm (page 19) and decreasing the down limit.

- **If the opener reverses in fully closed position:**

Decrease down travel. Turn the down limit adjustment screw clockwise. One turn equals 2" (5 cm) of travel.

WARNING

Without a properly installed safety reversal system, persons (particularly small children) could be SERIOUSLY INJURED or KILLED by a closing garage door.

- Incorrect adjustment of garage door travel limits will interfere with proper operation of safety reversal system.
- If one control (force or travel limits) is adjusted, the other control may also need adjustment.
- After ANY adjustments are made, the safety reversal system MUST be tested. Door MUST reverse on contact with 1-1/2" (3.8 cm) high object (or 2x4 laid flat) on floor.

CAUTION

To prevent damage to vehicles, be sure fully open door provides adequate clearance.

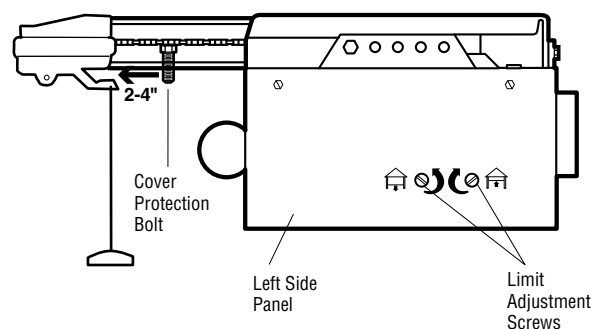

Adjustment Label

- **If the door reverses when closing and there is no visible interference to travel cycle:**

If the opener lights are flashing, the Safety Reversing Sensors are either not installed, misaligned, or obstructed. See Troubleshooting, page 17.

Test the door for binding: Pull the emergency release handle. Manually open and close the door. If the door is binding or unbalanced, call for a trained door systems technician. If the door is balanced and not binding, adjust the DOWN (close) force. See Adjustment Step 2.

ADJUSTMENT STEP 2

Adjust the Force

Force adjustment controls are located on the back panel of the motor unit. Force adjustment settings regulate the amount of power required to open and close the door.

If the forces are set too light, door travel may be interrupted by nuisance reversals in the down direction and stops in the up direction. Weather conditions can affect the door movement, so occasional adjustment may be needed.

The maximum force adjustment range is about 3/4 of a complete turn. Do not force controls beyond that point. Turn force adjustment controls with a screwdriver.

NOTE: If anything interferes with the door's upward travel, it will stop. If anything interferes with the door's downward travel (including binding or unbalanced doors), it will reverse.

HOW AND WHEN TO ADJUST THE FORCES

1. Test the DOWN (close) force

- Grasp the door bottom when the door is about halfway through DOWN (close) travel. The door should reverse. *Reversal halfway through down travel does not guarantee reversal on a 1-1/2" (3.8 cm) obstruction. See Adjustment Step 3, page 22.* **If the door is hard to hold or doesn't reverse**, DECREASE the DOWN (close) force by turning the control counterclockwise. Make small adjustments until the door reverses normally. After each adjustment, run the opener through a complete cycle.
- If the door reverses during the down (close) cycle and the opener lights aren't flashing**, INCREASE DOWN (close) force by turning the control clockwise. Make small adjustments until the door completes a close cycle. After each adjustment, run the opener through a complete travel cycle. *Do not increase the force beyond the minimum amount required to close the door.*

2. Test the UP (open) force

- Grasp the door bottom when the door is about halfway through UP (open) travel. The door should stop. **If the door is hard to hold or doesn't stop**, DECREASE UP (open) force by turning the control counterclockwise. Make small adjustments until the door stops easily and opens fully. After each adjustment, run the opener through a complete travel cycle.
- If the door doesn't open at least 5 feet (1.5 m)**, INCREASE UP (open) force by turning the control clockwise. Make small adjustments until door opens completely. Readjust the UP limit if necessary. After each adjustment, run the opener through a complete travel cycle.

⚠ WARNING

Without a properly installed safety reversal system, persons (particularly small children) could be **SERIOUSLY INJURED** or **KILLED** by a closing garage door.

- Too much force on garage door will interfere with proper operation of safety reversal system.
- NEVER** increase force beyond minimum amount required to close garage door.
- NEVER** use force adjustments to compensate for a binding or sticking garage door.
- If one control (force or travel limits) is adjusted, the other control may also need adjustment.
- After **ANY** adjustments are made, the safety reversal system **MUST** be tested. Door **MUST** reverse on contact with 1-1/2" (3.8 cm) high object (or 2x4 laid flat) on floor.

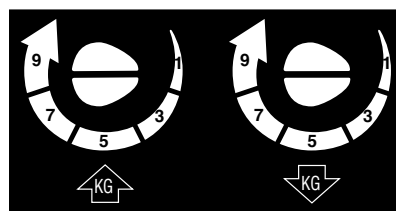
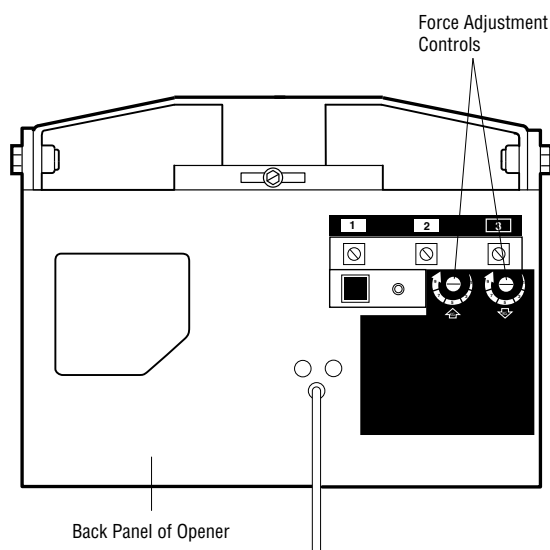

Adjustment Label

ADJUSTMENT STEP 3

Test the Safety Reversal System

TEST

- With the door fully open, place a 1-1/2" (3.8 cm) board (or a 2x4 laid flat) on the floor, centered under the garage door.
- Operate the door in the down direction. The door must reverse on striking the obstruction.

ADJUST

- If the door stops on the obstruction, it is not traveling far enough in the down direction. Increase the DOWN limit by turning the DOWN limit adjustment screw counterclockwise 1/4 turn.

NOTE: On a sectional door, make sure limit adjustments do not force the door arm beyond a straight up and down position. See the illustration on page 19.

- Repeat the test.
- When the door reverses on the 1-1/2" (3.8 cm) board, remove the obstruction and run the opener through 3 or 4 complete travel cycles to test adjustment.

IMPORTANT SAFETY CHECK:

Repeat Adjustment Steps 1, 2 and 3 after:

- Each adjustment of door arm length, limits, or force controls.
- Any repair to or adjustment of the garage door (including springs and hardware).
- Any repair to or buckling of the garage floor.
- Any repair to or adjustment of the opener.

ADJUSTMENT STEP 4

Test the Protector System®

- Press the remote control push button to open the door.
- Place the opener carton in the path of the door.
- Press the remote control push button to close the door. The door will not move more than an inch (2.5 cm), and the opener lights will flash.

The garage door opener will not close from a remote if the indicator light in either sensor is off (alerting you to the fact that the sensor is misaligned or obstructed).

If the opener closes the door when the safety reversing sensor is obstructed (and the sensors are no more than 6" [15 cm] above the floor), call for a trained door systems technician.

⚠ WARNING

Without a properly installed safety reversal system, persons (particularly small children) could be **SERIOUSLY INJURED** or **KILLED** by a closing garage door.

- Safety reversal system **MUST** be tested every month.
- If one control (force or travel limits) is adjusted, the other control may also need adjustment.
- After **ANY** adjustments are made, the safety reversal system **MUST** be tested. Door **MUST** reverse on contact with 1-1/2" (3.8 cm) high object (or 2x4 laid flat) on the floor.

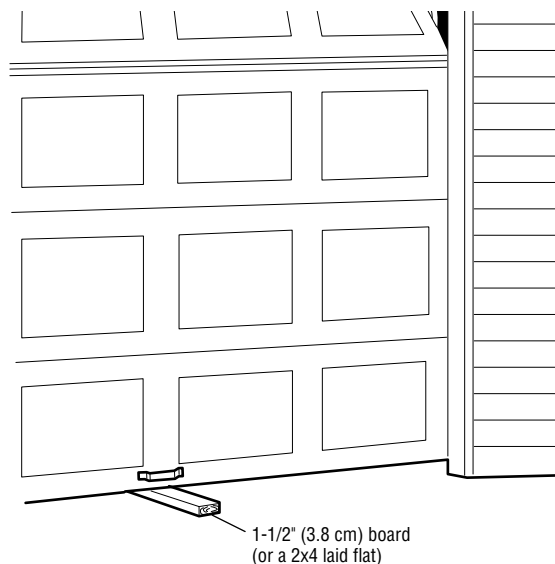

⚠ WARNING

Without a properly installed safety reversing sensor, persons (particularly small children) could be **SERIOUSLY INJURED** or **KILLED** by a closing garage door.

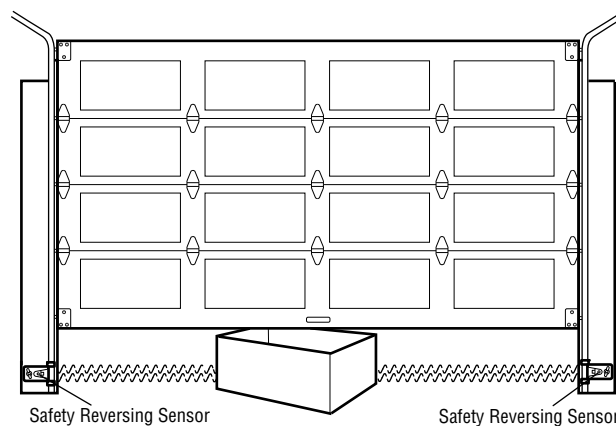

OPERATION

IMPORTANT SAFETY INSTRUCTIONS

WARNING

To reduce the risk of SEVERE INJURY or DEATH:

1. READ AND FOLLOW ALL WARNINGS AND INSTRUCTIONS.
2. ALWAYS keep remote controls out of reach of children. NEVER permit children to operate or play with garage door control push buttons or remote controls.
3. ONLY activate garage door when it can be seen clearly, it is properly adjusted, and there are no obstructions to door travel.
4. ALWAYS keep garage door in sight until completely closed. NO ONE SHOULD CROSS THE PATH OF THE MOVING DOOR.
5. NO ONE SHOULD GO UNDER A STOPPED, PARTIALLY OPEN DOOR.
6. If possible, use emergency release handle to disengage trolley ONLY when garage door is CLOSED. Weak or broken springs or unbalanced door could result in an open door falling rapidly and/or unexpectedly.
7. NEVER use emergency release handle unless garage doorway is clear of persons and obstructions.
8. NEVER use handle to pull garage door open or closed. If rope knot becomes untied, you could fall.
9. If one control (force or travel limits) is adjusted, the other control may also need adjustment.
10. After ANY adjustments are made, the safety reversal system MUST be tested.
11. Safety reversal system MUST be tested every month. Garage door MUST reverse on contact with 1-1/2" (3.8 cm) high object (or a 2x4 laid flat) on the floor.
12. ALWAYS KEEP GARAGE DOOR PROPERLY BALANCED (see page 3). An improperly balanced door may not reverse when required and could result in SEVERE INJURY or DEATH.
13. ALL repairs to cables, spring assemblies and other hardware, ALL of which are under EXTREME tension, MUST be made by a trained door systems technician.
14. ALWAYS disconnect electric power to garage door opener BEFORE making ANY repairs or removing covers.
15. **SAVE THESE INSTRUCTIONS.**

Using Your Garage Door Opener

Your opener will operate with up to eight Security+® remote controls and one Security+® Keyless Entry System.

Activate your opener with any of the following:

- *The hand-held Remote Control:* Hold the large push button down until the door starts to move.
- *The wall-mounted Door Control:* Hold the push button or bar down until the door starts to move.
- *The Keyless Entry (See Accessories):* If provided with your garage door opener, it must be programmed before use. See *Programming*.

When the opener is activated (with the safety reversing sensor correctly installed and aligned)

1. If open, the door will close. If closed, it will open.
2. If closing, the door will reverse.
3. If opening, the door will stop.
4. If the door has been stopped in a partially open position, it will close.
5. If obstructed while closing, the door will reverse. If the obstruction interrupts the sensor beam, the opener lights will blink for five seconds.
6. If obstructed while opening, the door will stop.
7. If fully open, the door will not close when the beam is broken. The sensor has no effect in the opening cycle.

If the sensor is not installed, or is misaligned, the door won't close from a hand-held remote. However, you can close the door with the Door Control, the Outside Keylock, or Keyless Entry, *if you activate them until down travel is complete*. If you release them too soon, the door will reverse.

The opener lights will turn on under the following conditions: when the opener is initially plugged in; when power is restored after interruption; when the opener is activated.

They will turn off automatically after 4-1/2 minutes. Bulb size is 75 watts maximum.

Security+® light feature: Lights will also turn on when someone walks through the open garage door.

Do not exceed 8 complete cycles of door operation per hour in commercial applications.

Using the Wall-Mounted Door Control

Press the push button to open or close the door. Press again to reverse the door during the closing cycle or to stop the door while it's opening.

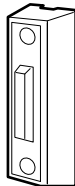

To Open the Door Manually

⚠ WARNING

To prevent possible **SERIOUS INJURY** or **DEATH** from a falling garage door:

- If possible, use emergency release handle to disengage trolley **ONLY** when garage door is **CLOSED**. Weak or broken springs or unbalanced door could result in an open door falling rapidly and/or unexpectedly.
- **NEVER** use emergency release handle unless garage doorway is clear of persons and obstructions.
- **NEVER** use handle to pull door open or closed. If rope knot becomes untied, you could fall.

The door should be fully closed if possible. Pull down on the emergency release handle and lift the door manually. To reconnect the door to the opener, press the door control push bar.

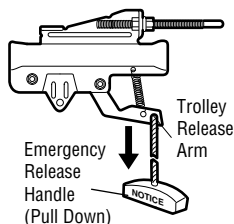

MANUAL DISCONNECT POSITION

The *lockout feature* prevents the trolley from reconnecting automatically. Pull the emergency release handle down and back (toward the opener). The door can then be raised and lowered manually as often as necessary. To disengage the lockout feature, pull the handle straight down. The trolley will reconnect on the next UP or DOWN operation.

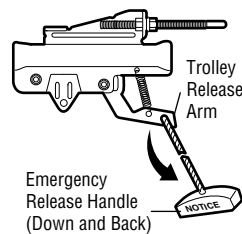

LOCKOUT POSITION

CARE OF YOUR OPENER

LIMIT AND FORCE ADJUSTMENTS:

Weather conditions may cause some minor changes in door operation requiring some re-adjustments, particularly during the first year of operation.

Pages 20 and 21 refer to the limit and force adjustments. Only a screwdriver is required. Follow the instructions carefully.

FORCE CONTROLS

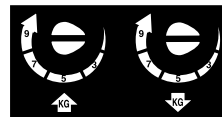

LIMIT CONTROLS



Repeat the safety reverse test (Adjustment Step 3, page 22) after any adjustment of limits or force.

MAINTENANCE SCHEDULE

Once a Month

- Manually operate door. If it is unbalanced or binding, call a trained door systems technician.
- Check to be sure door opens & closes fully. Adjust limits and/or force if necessary. (See pages 20 and 21.)
- Repeat the safety reverse test. Make any necessary adjustments. (See Adjustment Step 3.)

Twice a Year

- Check chain tension. Disconnect trolley first. Adjust if necessary (See page 7).

Once a Year

- Oil door rollers, bearings and hinges. The opener does not require additional lubrication. Do not grease the door tracks.

Having a Problem?

1. The opener doesn't operate from either the Door Control or the remote control:

- Does the opener have electric power? Plug a lamp into the outlet. If it doesn't light, check the fuse box or the circuit breaker. (Some outlets are controlled by a wall switch.)
- Have you disabled all door locks? Review installation instruction warnings on page 7.
- Is there a build-up of ice or snow under the door? The door may be frozen to the ground. Remove any restriction.
- The garage door spring may be broken. Have it replaced.
- Repeated operation may have tripped the overload protector in the motor. Wait 15 minutes and try again.

2. Opener operates from the remote, but not from the Door Control:

- Is the door control lit? If not, reverse the wires. If the opener runs, check for a faulty wire connection at the door control, a short under the staples, or a broken wire.
- Are the wiring connections correct? Review *Installation Step 6*, page 12.

3. The door operates from the Door Control, but not from the remote control:

- Is the door push bar flashing? If your model has the Lock feature, make sure it is off.
- Program the opener to match the remote control code. (Refer to instructions on the motor unit panel.) Repeat with all remotes.

4. The remote control has short range:

- Change the location of the remote control in your car.
- Check to be sure the antenna on the side or back panel of motor unit extends fully downward.
- Some installations may have shorter range due to a metal door, foil backed insulation, or metal garage siding.

5. Opener noise is disturbing in living quarters of home:

- If operational noise is a problem because of proximity of the opener to the living quarters, the Vibration Isolator Kit 89LM can be installed. This kit was designed to minimize vibration to the house and is easy to install.

6. The garage door opens and closes by itself:

- Be sure that all remote control push buttons are off.
- Remove the bell wire from the door control terminals and operate from the remote only. If this solves the problem, the door control is faulty (replace), or there is an intermittent short on the wire between the door control and the motor unit.
- Clear memory and re-program all remote controls.

7. The door doesn't open completely:

- Is something obstructing the door? Is it out of balance, or are the springs broken? Remove the obstruction or repair the door.
- If the door is in good working order but now doesn't open all the way, increase the up force. See *Adjustment Step 2*.
- If the door opens at least 5 feet (1.5 m), the travel limits may need to be increased. One turn equals 2" (5 cm) of travel. See *Adjustment Step 1*.

Repeat the safety reverse test after the adjustment is complete.

8. The door stops but doesn't close completely:

- Review the travel limits adjustment procedures on page 20.
- Repeat the safety reverse test after any adjustment of door arm length, close force or down limit.

9. The door opens but won't close:

- If the opener lights blink, check the safety reversing sensor. See *Installation Step 10*.
- If the opener lights don't blink and it is a new installation, check the down force. See *Adjustment Step 2*. For an existing installation, see below.

Repeat the safety reverse test after the adjustment is complete.

10. The door reverses for no apparent reason and opener lights don't blink:

- Is something obstructing the door? Pull the emergency release handle. Operate the door manually. If it is unbalanced or binding, call a trained door systems technician.
- Clear any ice or snow from the garage floor area where the door closes.
- Review *Adjustment Step 2*.
- If door reverses in the fully closed position, decrease the travel limits (*Adjustment Step 1*).

Repeat safety reverse test after adjustments to force or travel limits. The need for occasional adjustment of the force and limit settings is normal. Weather conditions in particular can affect door travel.

11. The door reverses for no apparent reason and opener lights blink for 5 seconds after reversing:

- Check the safety reversing sensor. Remove any obstruction or align the receiving eye. See *Installation Step 10*.

12. The opener lights don't turn on:

- Replace the light bulbs (75 watts maximum). Use a standard neck garage door opener bulb if regular bulb burns out.

13. The opener lights don't turn off:

- Is the Light feature on? Turn it off.

14. The opener strains or maximum force is needed to operate door:

- The door may be out of balance or the springs may be broken. **Close the door** and use the emergency release handle to disconnect the trolley. Open and close the door manually. A properly balanced door will stay in any point of travel while being supported entirely by its springs. If it does not, disconnect the opener and call a trained door systems technician. **Do not increase the force to operate the opener.**

15. The opener motor hums briefly, then won't work:

- The garage door springs may be broken. See above.
- If the problem occurs on the first operation of the opener, door may be locked. Disable the door lock.

Repeat the safety reverse test after the adjustment is complete.

16. The opener won't operate due to power failure:

- Use the emergency release handle to disconnect the trolley. The door can be opened and closed manually. When power is restored, press the Door Control push bar and trolley will automatically reconnect (unless trolley is in lockout position.) See page 24.
- The Outside Quick Release accessory (for use on garages with no service door) disconnects the trolley from outside the garage in case of power failure.

17. The chain droops or sags:

- It is normal for the chain to droop slightly in the closed door position. Use the emergency release rope and handle to disconnect the trolley. If the chain returns to the normal height when the trolley is disengaged, and the door reverses on a 2x4 laid flat, no adjustments are needed. (See page 7.)

PROGRAMMING

NOTICE: If this Security+® garage door opener is operated with a non-rolling code transmitter, the technical measure in the receiver of the garage door opener, which provides security against code-theft devices, will be circumvented. The owner of the copyright in the garage door opener does not authorize the purchaser or supplier of the non-rolling code transmitter to circumvent that technical measure.

Security+® 3-Button Remote Control Programming (Optional)

The 300 Series remote control works only with door openers and light controls having a purple “Learn” button.

Programming instructions are described and illustrated below. The additional push buttons can also activate other garage door openers and/or light controls. (Instructions for programming light products are included with those accessories.)

Instructions are Described and Illustrated Below

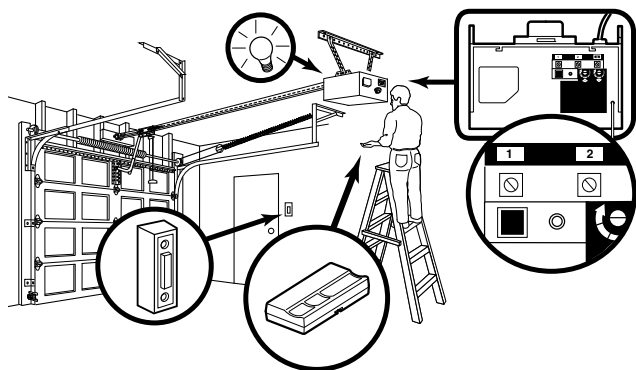

1. Press and release the “learn” button on the motor unit. The learn indicator light will glow steadily for 30 seconds.
2. Within 30 seconds, press and hold the button on the hand-held remote.
3. Release the button when the motor unit light blinks. It has learned the code. If light bulbs are not installed, two clicks will be heard.

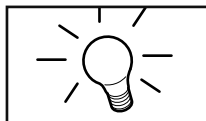
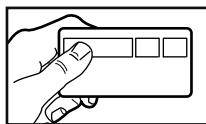
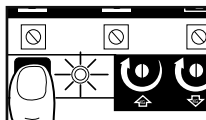

To Erase All Codes From Motor Unit Memory

To deactivate any unwanted remote, first erase all codes:

Press and hold the “learn” button on motor unit until the learn indicator light goes out (approximately 6 seconds). All previous codes are now erased. Reprogram each remote or keyless entry you wish to use.

To Control the Opener Lights

With Security+® transmitters, a remote push button can be programmed to operate the opener lights without opening the door.

1. With the door closed, press and hold the remote button that you want to control the light.
2. Press and hold the Light button on the door control.
3. Press and hold the Lock button on the door control.
4. After the opener lights flash, release all buttons.

Test by pressing the remote push button. The opener lights should turn on or off but the door should not move.

⚠ WARNING

To prevent possible **SERIOUS INJURY** or **DEATH** from a moving gate or garage door:

- ALWAYS keep remote controls out of reach of children. NEVER permit children to operate, or play with remote control transmitters.
- Activate gate or door ONLY when it can be seen clearly, is properly adjusted, and there are no obstructions to door travel.
- ALWAYS keep gate or garage door in sight until completely closed. NEVER permit anyone to cross path of moving gate or door.

Open/Close/Stop Operation

Your Security+® remote control can be programmed to operate one door using all 3 buttons: the large button will only open the door, the middle button will close the door and third button will stop the door’s movement. You may set up this feature as follows:

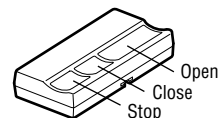

1. With the door closed, press and hold the large remote push button.
2. Press and hold the Lock button on the door control.
3. Press and hold the door control push bar.

When the opener lights flash, release all buttons. Test by pressing the large (Open) button on the remote. The door should open. Press it again while the door is open and nothing should happen. Press the middle (Close) button and the door should close. Press the third (Stop) button while the door is moving and it should stop immediately.

Remote Control Batteries

⚠ WARNING

To prevent possible **SERIOUS INJURY** or **DEATH**:

- NEVER allow small children near batteries.
- If battery is swallowed, immediately notify doctor.

The lithium batteries should produce power for up to 5 years. To replace, pry open case with visor clip or screwdriver, as shown. Insert batteries positive side up (+).

Dispose of old batteries properly.

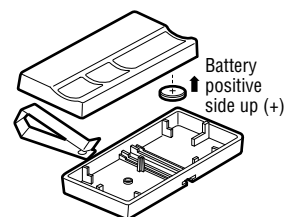

NOTICE: To comply with FCC and/or Industry Canada (IC) rules, adjustment or modifications of this receiver and/or transmitter are prohibited, except for changing the code setting or replacing the battery. THERE ARE NO OTHER USER SERVICEABLE PARTS.

Tested to Comply with FCC Standards FOR HOME OR OFFICE USE. Operation is subject to the following two conditions: (1) this device may not cause harmful interference, and (2) this device must accept any interference received, including interference that may cause undesired operation.

To Add or Change a Keyless Entry PIN (Optional)

NOTE: Your new Keyless Entry must be programmed to operate your garage door opener.

USING THE “LEARN” BUTTON

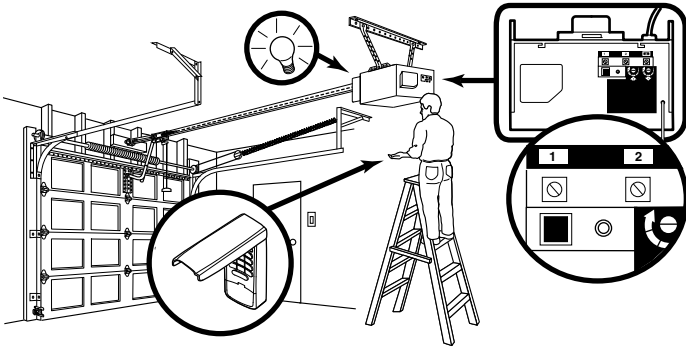

1. Press and release the “learn” button on motor unit. The learn indicator light will glow steadily for 30 seconds.
2. Within 30 seconds, enter a four digit personal identification number (PIN) of your choice on the keypad. Then press and hold the enter button.
3. Release the button when the motor unit lights blink. It has learned the code. If light bulbs are not installed, two clicks will be heard.

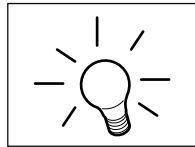
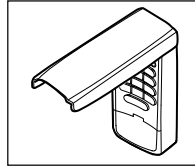
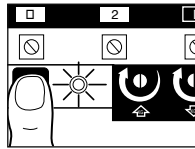

To change an existing, known PIN

If the existing PIN is known, it may be changed by one person without using a ladder.

1. Press the four buttons for the present PIN, then press and hold the # button.

The opener light will blink twice. Release the # button.

2. Press the new 4-digit PIN you have chosen, then press ENTER.

The motor unit lights will blink once when the PIN has been learned.

Test by pressing the new PIN, then press ENTER. The door should move.

To set a temporary PIN

You may authorize access by visitors or service people with a temporary 4-digit PIN. After a programmed number of hours or number of accesses, this temporary PIN expires and will no longer open the door. It can be used to *close* the door even after it has expired. To set a temporary PIN:

1. Press the four buttons for your personal entry PIN (not the last temporary PIN), then press and hold the * button.

The opener light will blink three times. Release the button.

2. Press the temporary 4-digit PIN you have chosen, then press ENTER.

The opener light will blink four times.

3. To set the number of hours this temporary PIN will work, press the number of **hours** (up to 255), then press *.

OR

3. To set the number of **times** this temporary PIN will work, press the number of times (up to 255), then press #.

The opener light will blink once when the temporary PIN has been learned.

Test by pressing the four buttons for the temporary PIN, then press ENTER. The door should move. If the temporary PIN was set to a certain number of openings, remember that the test has used up one opening. To clear the temporary password, repeat steps 1-3, setting the number of hours or times to 0 in step 3.

Multi-Function Door Control (Optional)

INSTALLATION

Locate door control within sight of the door at a minimum height of 5 feet (1.5 m) where small children cannot reach, and away from moving parts of the door and door hardware. If installing into drywall, drill 5/32" holes and use anchors provided. For pre-wired installations (as in new home construction), it may be mounted to a single gang box. **NOTE:** After installation, a green indicator light behind the cover will indicate proper connection. If not lit, the Lock and Light features will not function (reverse wires to correct).

- Strip 1/4" (6 mm) of insulation from one end of bell wire and connect to the two screw terminals on back of door control by color: white wire to 2 and white/red wire to 1.
- Remove cover by gently pushing both thumbs against upper corners of cover on back side of door control. Fasten with 6ABx1-1/4" self-tapping screws (standard installation) or 6-32x1" machine screws (into gang box) as follows:
 - Drill and install bottom screw, allowing 1/8" (3 mm) to protrude above wall surface.
 - Position bottom of door control on screw head and slide down to secure. Adjust screw for snug fit.
 - Install top screw with care to avoid cracking plastic housing. **DO NOT overtighten.**
 - Insert bottom tabs and snap on cover. (To remove cover after mounting, gently pry at top with paper clip or small flat head screwdriver.)
- (Standard installation only)** Run bell wire up wall and across ceiling to motor unit. Use insulated staples to secure wire in several places. Do not pierce wire with a staple, creating a short or open circuit.
- Connect bell wire to the opener terminal screws: white to 2 and white/red to 1.
- Use tacks or staples to permanently attach entrapment warning label to wall near door control, and manual release/safety reverse test label in a prominent location on inside of garage door.

NOTE: DO NOT connect the power and operate the opener at this time. The trolley will travel to the full open position but will not return to the close position until the sensor beam is connected and properly aligned. See Safety Reversing Sensor Instructions beginning on page 15.

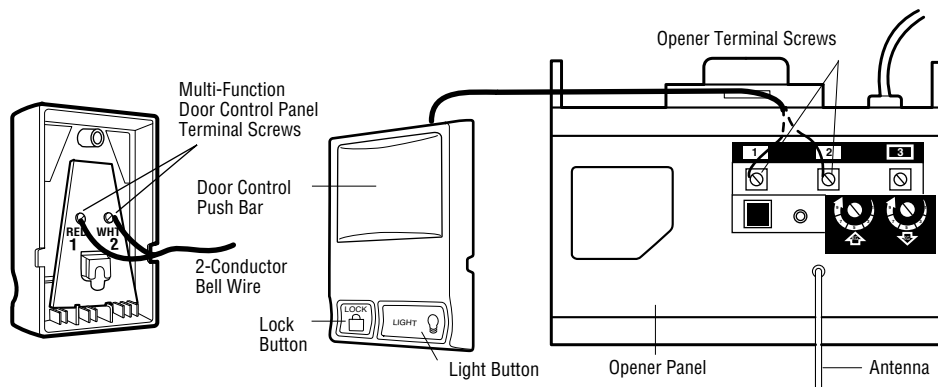

⚠️ WARNING

To prevent possible SERIOUS INJURY OR DEATH from electrocution:

- Be sure power is not connected BEFORE installing door control.
- Connect ONLY to 24 VOLT low voltage wires.

To prevent possible SERIOUS INJURY or DEATH from a closing garage door:

- Install door control within sight of garage door, out of reach of children at a minimum height of 5 feet (1.5 m), and away from ALL moving parts of door.
- NEVER permit children to operate or play with door control push buttons or remote control transmitters.
- Activate door ONLY when it can be seen clearly, is properly adjusted, and there are no obstructions to door travel.
- ALWAYS keep garage door in sight until completely closed. NEVER permit anyone to cross path of closing garage door.

OPERATION OF THE MULTI-FUNCTION DOOR CONTROL

Press the push button to open or close the door. Press again to reverse the door during the closing cycle or to stop the door while it's opening.

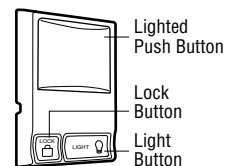

Light feature

Press the Light button to turn the opener light on or off. It will not control the opener lights when the door is in motion. If you turn it on and then activate the opener, the light will remain on for 4-1/2 minutes. Press again to turn it off sooner. The 4-1/2 minute interval can be changed to 1-1/2, 2-1/2, or 3-1/2 minutes as follows: Press and hold the Lock button until the light blinks (about 10 seconds). A single blink indicates that the timer is reset to 1-1/2 minutes. Repeat the procedure and the light will blink twice, resetting the timer to 2-1/2 minutes. Repeat again for a 3-1/2 minute interval, etc., up to a maximum of four blinks and 4-1/2 minutes.

Lock feature

Designed to prevent operation of the door from hand-held remote controls. However, the door will open and close from the Door Control and the Keyless Entry Accessories.

To activate, press and hold the Lock button for 2 seconds. The push bar light will flash as long as the Lock feature is on.

To turn off, press and hold the Lock button again for 2 seconds. The push bar light will stop flashing. The Lock feature will also turn off whenever the "learn" button on the motor unit panel is activated.

REPAIR PARTS

Rail Assembly Parts

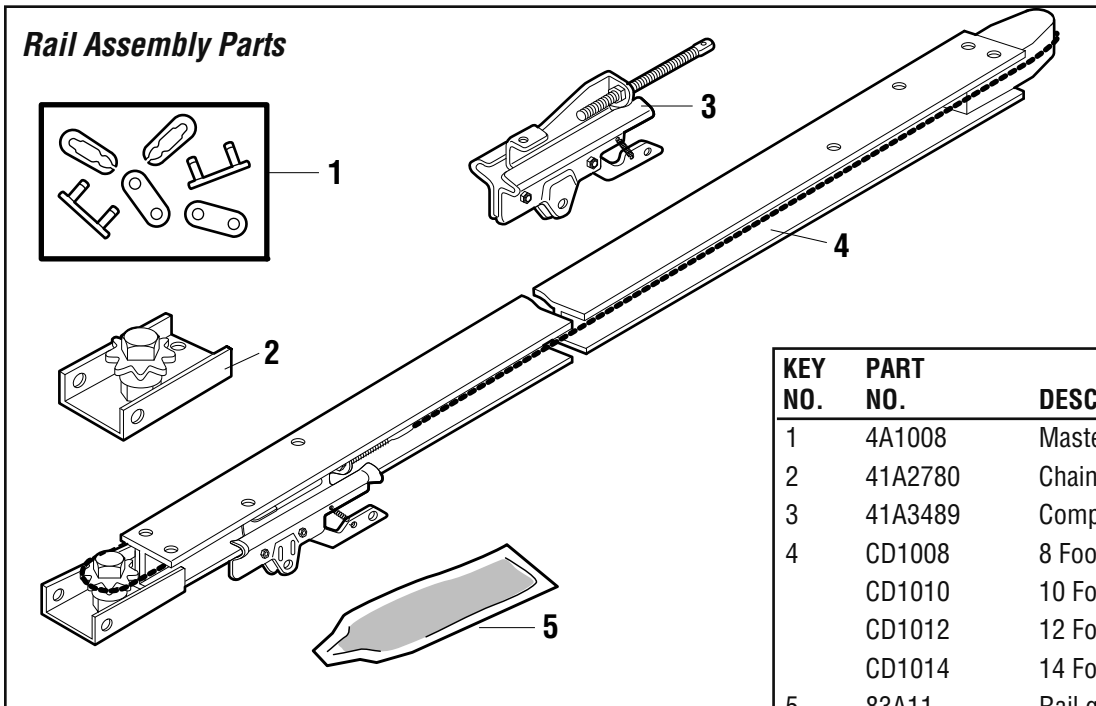

KEY NO.	PART NO.	DESCRIPTION
1	4A1008	Master link kit
2	41A2780	Chain pulley bracket
3	41A3489	Complete trolley assembly
4	CD1008	8 Foot (2.44 m) Rail Assy.
	CD1010	10 Foot (3.05 m) Rail Assy.
	CD1012	12 Foot (3.66 m) Rail Assy.
	CD1014	14 Foot (4.27 m) Rail Assy.
5	83A11	Rail grease
NOT SHOWN		
6	41C771	Center Bracket (1 pc.)

Installation Parts

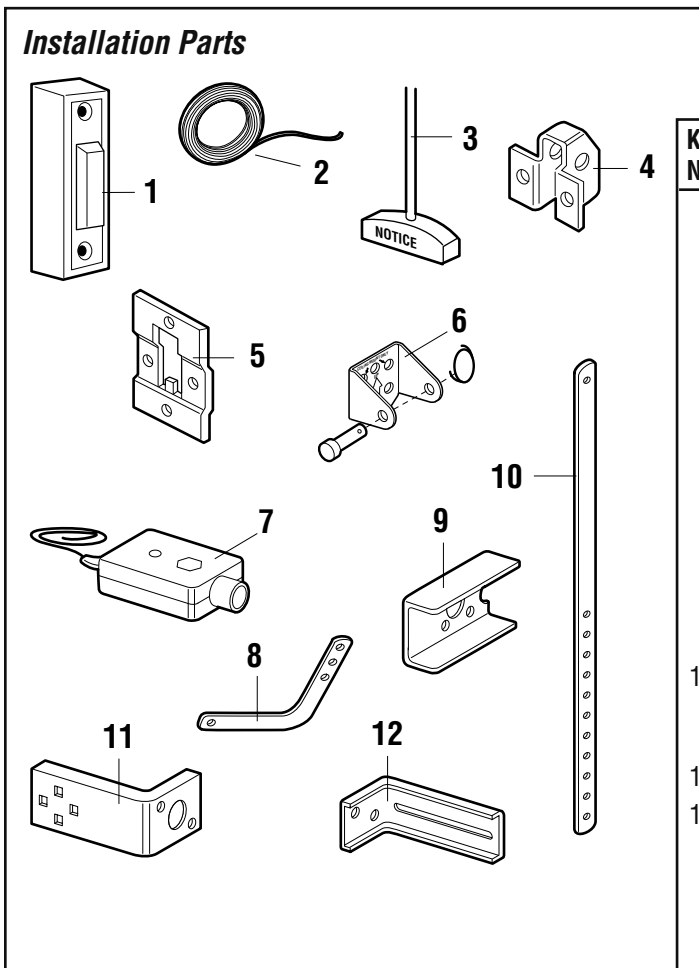

KEY NO.	PART NO.	DESCRIPTION
1	41A4166	Door control push button
2	41B4494-1	2-conductor bell wire, white & white/red
3	41A2828	Emergency release rope & handle assembly
4	12B374	Door bracket
5	12B380	Door bracket plate
6	41A4353	Header bracket w/clevis pin & fastener
7	41A4373A	Safety sensor kit (receiving and sending eyes) with 3' (0.9 m) 2-conductor bell wire attached
8	178B35	Curved door arm section
9	12B483	C Wrap bracket
10	178B34	Straight door arm section
	178B73	Straight door arm section (14ft. (4.27 m) door)
11	12B484	Square hole mounting bracket
12	12B485	Slotted mounting bracket
NOT SHOWN		
	41A2770	Installation hardware bag (page 5).
	41A4116	Safety sensor hardware
	114A3155	Owner's manual
	114A3155SP	Owner's manual - Spanish

Motor Unit Assembly Parts

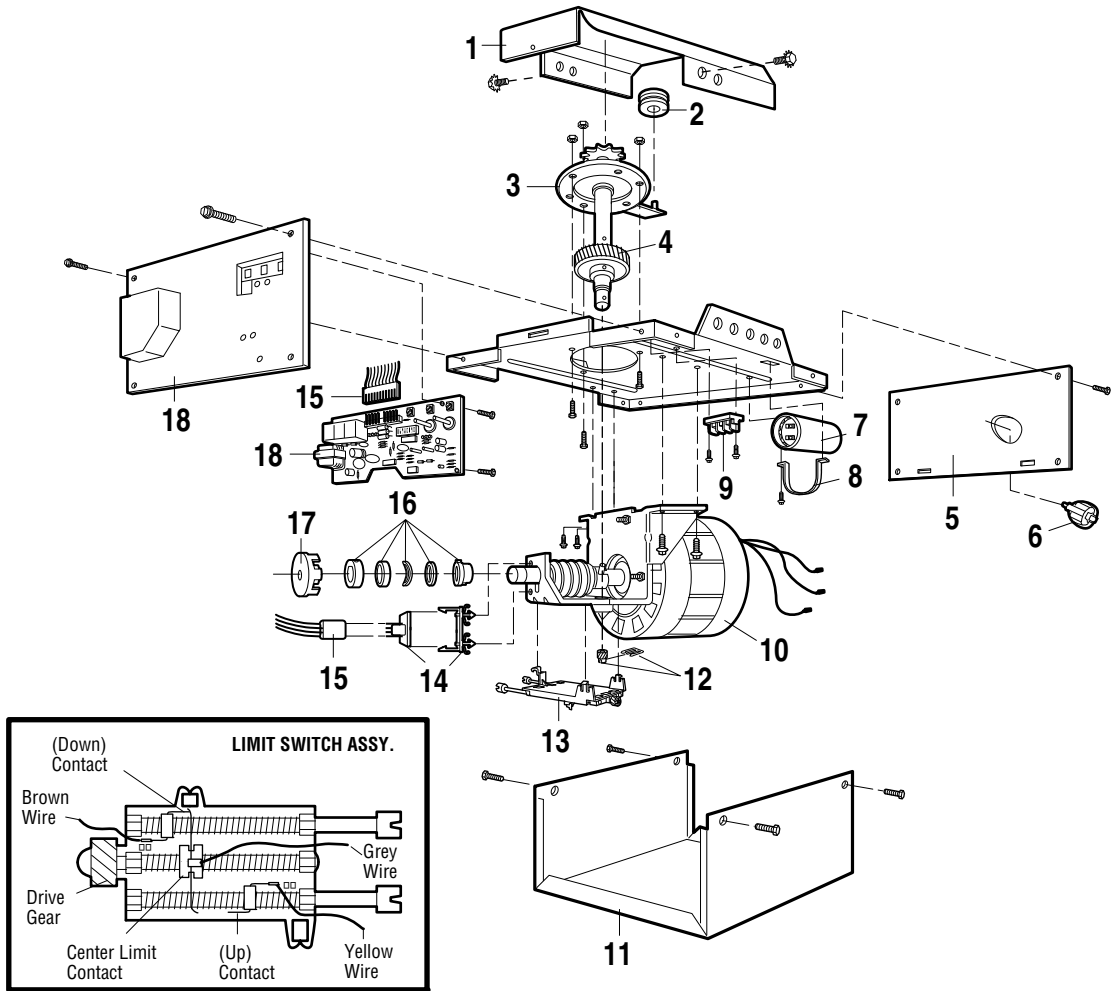

KEY NO.	PART NO.	DESCRIPTION	KEY NO.	PART NO.	DESCRIPTION
1.	41C5069	Rail support bracket assembly kit	10.	41D4509	Replacement motor & bracket assembly
2.	41B4569	Pulley (Chain)			Complete with: Motor, worm, bracket, bearing assembly
3.	41A5668	Gear and sprocket assembly. Complete with: Spring washer, thrust washer, retaining washer, bearing plate roll pins (2), drive gear and worm gear, helical gear w/retainer and grease, sprocket shaft plate with screws	11.	41A4593-5	Cover
4.	41A2817	Drive/worm gear kit w/grease Roll pins (2)	12.	81C253	Helical gear & retainer w/grease
5.	143D100-1	Front end panel	13.	41A5640	Limit switch assembly
6.	175B88	Light socket	14.	41C4398A	RPM sensor assembly
7.	30B532	Capacitor	15.	41C4246	Wire harness assembly w/plug
8.	12A461	Capacitor bracket	16.	41A2826	Shaft bearing kit
9.	41A3150	Terminal block with screws	17.	41A2822A	Interrupter cup assembly
			18.	41A5021-9G-315	Receiver logic board assembly Complete with: Logic board, end panel with all labels
					NOT SHOWN
				41A2825	Opener assembly hardware kit (includes screws not designated by a number in illustration).

ACCESSORIES

1702LM

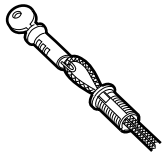

Outside Quick Release:

Required for a garage with NO access door. Enables homeowner to open garage door manually from outside by disengaging trolley.

59LM

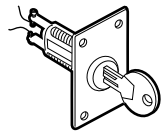

Outside Keylock:

Opens the garage door automatically from outside when remote control is not handy.

180C139

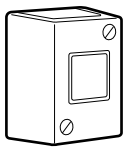

NEMA 1 Push Button:

Heavy Duty Door Control Push Button (one button).

CD1008

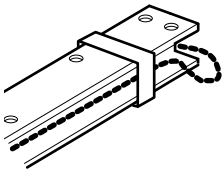

8 Foot (2.44 m) Complete Rail:

To allow an 8 foot (2.44 m) door to open fully.

CD1010

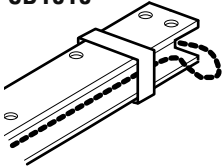

10 Foot (3.05 m) Complete Rail:

To allow a 10 foot (3.05 m) door to open fully.

CD1012

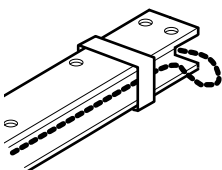

12 Foot (3.66 m) Complete Rail:

To allow a 12 foot (3.66 m) door to open fully.

CD1014

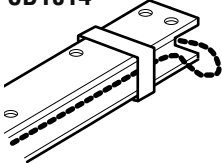

14 Foot (4.27 m) Complete Rail:

To allow a 14 foot (4.27 m) door to open fully.

108D36

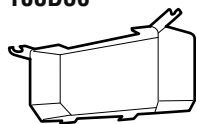

Light Lens Cover:

Attractive lens cover protects light bulbs and diffuses light to every corner of your garage.

371LM

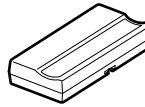

SECURITY+® 1-Button Remote Control:

Includes visor clip.

372LM

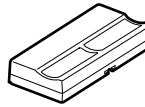

SECURITY+® 2-Button Remote Control:

Includes visor clip.

373LM

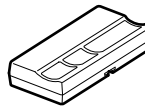

SECURITY+® 3-Button Remote Control:

Includes visor clip.

370LM



3-Button Mini-Remote Control with SECURITY+®:

With key ring and fastening strip.

78LM



Multi-Function Door Control Panel:

Provides a Lock Feature which prevents operation of garage door opener from portable remotes and a Light Feature for constant light.

376LM

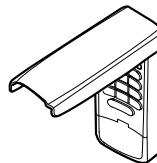

SECURITY+® Keyless Entry:

Enables homeowner to operate garage door opener from outside by entering a password on a specially designed keyboard. Also can add a temporary password for visitors or service persons. This temporary password can be limited to a programmable number of hours or entries.

50111

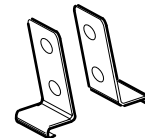

Center Bracket (6 pcs.):

Adds additional stability to a rail by enabling the use of additional hanging brackets if desired.

LIFTMASTER® SERVICE IS ON CALL

**OUR LARGE SERVICE ORGANIZATION
SPANS AMERICA**

**INSTALLATION AND SERVICE INFORMATION IS AS NEAR AS
YOUR TELEPHONE SIX DAYS A WEEK. SIMPLY DIAL OUR TOLL
FREE NUMBER:**

1-800-528-2817

HOURS: (Central Std. Time)

6:00 A.M. TO 7:00 P.M. - Monday through Friday

8:00 A.M. TO 6:00 P.M. - Saturday

8:00 A.M. TO 4:30 P.M. - Sunday

www.liftmaster.com

For professional installation, parts and service, contact your local LIFTMASTER/CHAMBERLAIN dealer. Look for him in the Yellow Pages, or call our Service number for a list of dealers in your area.

HOW TO ORDER REPAIR PARTS

Selling prices will be furnished on request or parts will be shipped at prevailing prices and you will be billed accordingly.

**WHEN ORDERING REPAIR PARTS, ALWAYS GIVE THE
FOLLOWING INFORMATION:**

- **PART NUMBER**
- **PART NAME**
- **MODEL NUMBER**

ADDRESS ORDERS TO:

THE CHAMBERLAIN GROUP, INC.
Technical Support Group
6020 S. Country Club Road
Tucson, Arizona 85706

SERVICE INFORMATION

TOLL FREE NUMBER:

1-800-528-2817

LIFTMASTER® ONE YEAR LIMITED WARRANTY LIFETIME MOTOR LIMITED WARRANTY

The Chamberlain Group, Inc. ("Seller") warrants to the first retail purchaser of this product, for the residence in which this product is originally installed, that it is free from defect in materials and/or workmanship for a period of one year from the date of purchase [and that the motor is free from defect in materials and/or workmanship for the lifetime of the product]. The proper operation of this product is dependent on your compliance with the instructions regarding installation, operation, maintenance and testing. Failure to comply strictly with those instructions will void this limited warranty in its entirety.

If, during the limited warranty period, this product appears to contain a defect covered by this limited warranty, call 1-800-528-2817, toll free, before dismantling this product. Then send this product, pre-paid and insured, to our service center for warranty repair. You will be advised of shipping instructions when you call. Please include a brief description of the problem and a dated proof-of-purchase receipt with any product returned for warranty repair. Products returned to Seller for warranty repair, which upon receipt by Seller are confirmed to be defective and covered by this limited warranty, will be repaired or replaced (at Seller's sole option) at no cost to you and returned pre-paid. Defective parts will be repaired or replaced with new or factory-rebuilt parts at Seller's sole option.

ALL IMPLIED WARRANTIES FOR THE PRODUCT, INCLUDING BUT NOT LIMITED TO ANY IMPLIED WARRANTIES OF MERCHANTABILITY AND FITNESS FOR A PARTICULAR PURPOSE, ARE LIMITED IN DURATION TO THE ONE YEAR LIMITED WARRANTY PERIOD SET FORTH ABOVE [EXCEPT THE IMPLIED WARRANTIES WITH RESPECT TO THE MOTOR, WHICH ARE LIMITED IN DURATION TO THE LIFETIME LIMITED WARRANTY PERIOD FOR THE MOTOR], AND NO IMPLIED WARRANTIES WILL EXIST OR APPLY AFTER SUCH PERIOD. Some States do not allow limitations on how long an implied warranty lasts, so the above limitation may not apply to you. THIS LIMITED WARRANTY DOES NOT COVER NON-DEFECT DAMAGE, DAMAGE CAUSED BY IMPROPER INSTALLATION, OPERATION OR CARE (INCLUDING, BUT NOT LIMITED TO ABUSE, MISUSE, FAILURE TO PROVIDE REASONABLE AND NECESSARY MAINTENANCE, UNAUTHORIZED REPAIRS OR ANY ALTERATIONS TO THIS PRODUCT), LABOR CHARGES FOR REINSTALLING A REPAIRED OR REPLACED UNIT, REPLACEMENT OF BATTERIES AND LIGHT BULBS OR UNITS INSTALLED FOR NON-RESIDENTIAL USE.

THIS LIMITED WARRANTY DOES NOT COVER ANY PROBLEMS WITH, OR RELATING TO, THE GARAGE DOOR OR GARAGE DOOR HARDWARE, INCLUDING BUT NOT LIMITED TO THE DOOR SPRINGS, DOOR ROLLERS, DOOR ALIGNMENT OR HINGES. THIS LIMITED WARRANTY ALSO DOES NOT COVER ANY PROBLEMS CAUSED BY INTERFERENCE. ANY SERVICE CALL THAT DETERMINES THE PROBLEM HAS BEEN CAUSED BY ANY OF THESE ITEMS COULD RESULT IN A FEE TO YOU.

UNDER NO CIRCUMSTANCES SHALL SELLER BE LIABLE FOR CONSEQUENTIAL, INCIDENTAL OR SPECIAL DAMAGES ARISING IN CONNECTION WITH USE, OR INABILITY TO USE, THIS PRODUCT. IN NO EVENT SHALL SELLER'S LIABILITY FOR BREACH OF WARRANTY, BREACH OF CONTRACT, NEGLIGENCE OR STRICT LIABILITY EXCEED THE COST OF THE PRODUCT COVERED HEREBY. NO PERSON IS AUTHORIZED TO ASSUME FOR US ANY OTHER LIABILITY IN CONNECTION WITH THE SALE OF THIS PRODUCT.

Some states do not allow the exclusion or limitation of consequential, incidental or special damages, so the above limitation or exclusion may not apply to you. This limited warranty gives you specific legal rights, and you may also have other rights which vary from state to state.