

CHAMBERLAIN®

**LiftMaster®**  
**PROFESSIONAL**

The Chamberlain Group, Inc.  
845 Larch Avenue  
Elmhurst, Illinois 60126-1196  
www.liftmaster.com



## **GARAGE DOOR OPENER**

### **Model 2500**

*For Residential Use Only*

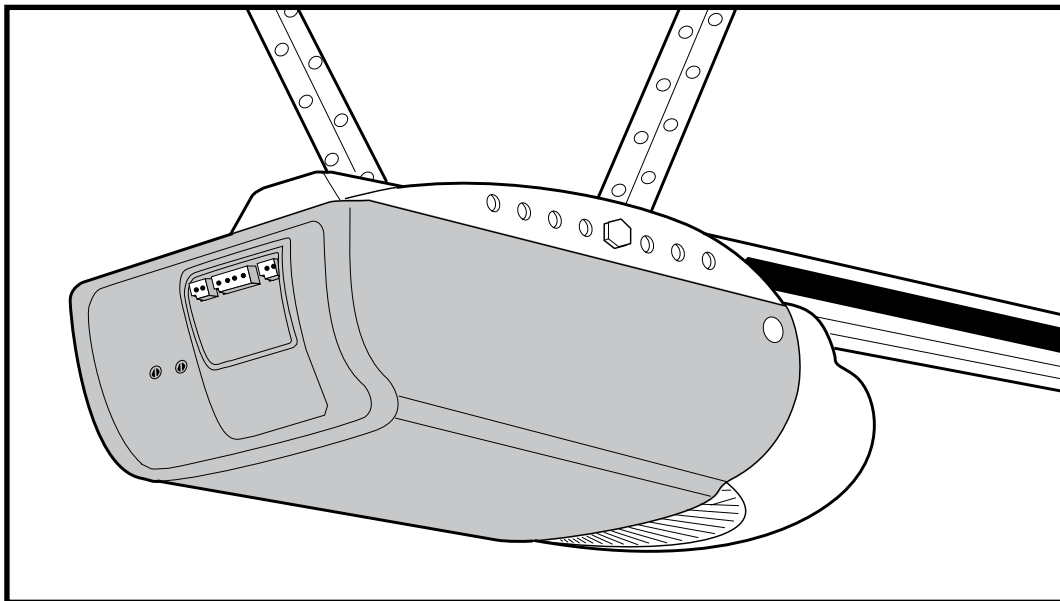

### ***Owner's Manual***

- Please read this manual and the enclosed safety materials carefully!
- Fasten the manual near the garage door after installation.
- The door **WILL NOT CLOSE** unless the Protector System® is connected and properly aligned.
- Periodic checks of the opener are required to ensure safe operation.
- The model number label is located on the front of your opener.

---

# TABLE OF CONTENTS

<b>Introduction</b>	<b>Pages 2-5</b>	<b>Adjustment</b>	<b>Pages 24-26</b>
Safety symbol review and signal word review.....	2	Program the travel limits.....	24
Preparing your garage door.....	3	Adjust the force.....	25
Tools.....	3	Test the safety reversal system.....	26
Planning.....	4	Test the Protector System®.....	26
Carton inventory.....	5	<b>Operation</b>	<b>Pages 27-30</b>
Hardware inventory.....	5	Operation safety instructions.....	27
<b>Assembly</b>	<b>Pages 6-7</b>	Using your garage door opener.....	27
Fasten rail to the motor unit.....	6	Using the door control.....	28
Set the belt tension.....	6	To open the door manually.....	28
Attach the belt cap retainer.....	7	Care of your garage door opener.....	29
<b>Installation</b>	<b>Pages 7-23</b>	Having a problem?.....	29-30
Installation safety instructions.....	7	<b>Programming</b>	<b>Pages 31-32</b>
Determine the header bracket location.....	8-9	To add a hand-held remote control.....	31
Install the header bracket.....	10	To erase all codes.....	31
Attach the rail to the header bracket.....	11	3-Channel remotes.....	31
Position the opener.....	12	To add or change a Keyless Entry PIN.....	32
Hang the opener.....	13	<b>Repair Parts</b>	<b>Pages 33-34</b>
Install the door control.....	14	Rail assembly parts.....	33
Install the lights and lens.....	15	Installation parts.....	33
Attach the emergency release rope and handle.....	15	Motor unit assembly parts.....	34
Electrical requirements.....	16	<b>Accessories</b>	<b>35</b>
Install the Protector System®.....	17-19	<b>Repair Parts and Service</b>	<b>36</b>
Fasten the door bracket.....	20-21	<b>Warranty</b>	<b>36</b>
Connect the door arm to the trolley.....	22-23		

---

## INTRODUCTION

### Safety Symbol Review

This garage door opener has been designed and tested to offer safe service provided it is installed, operated, maintained and tested in strict accordance with the instructions and warnings contained in this manual.

 **WARNING**

**Mechanical**

 **WARNING**

**Electrical**

**CAUTION**

When you see these Safety Symbols and Signal Words on the following pages, they will alert you to the possibility of **serious injury or death** if you do not comply with the warnings that accompany them. The hazard may come from something mechanical or from electric shock. Read the warnings carefully.

When you see this Signal Word on the following pages, it will alert you to the possibility of damage to your garage door and/or the garage door opener if you do not comply with the cautionary statements that accompany it. Read them carefully.

## Preparing your garage door

Before you begin:

- Disable locks.
- Remove any ropes connected to garage door.
- **Complete the following test** to make sure your garage door is balanced and is not sticking or binding:

1. Lift the door about halfway as shown. Release the door. If balanced, it should stay in place, supported entirely by its springs.
2. Raise and lower the door to see if there is any binding or sticking.

If your door binds, sticks, or is out of balance, call a trained door systems technician.

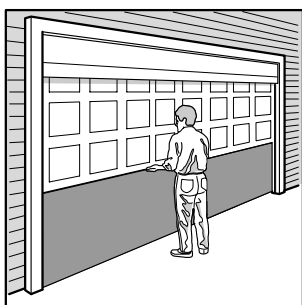

Sectional Door

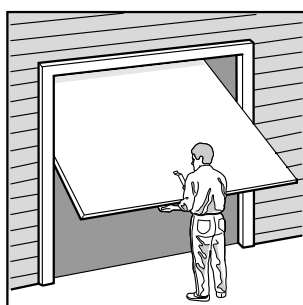

One-Piece Door

## ⚠ WARNING

To prevent possible **SERIOUS INJURY OR DEATH**:

- **ALWAYS** call a trained door systems technician if garage door binds, sticks, or is out of balance. An unbalanced garage door may not reverse when required.
- **NEVER** try to loosen, move or adjust garage door, door springs, cables, pulleys, brackets or their hardware, all of which are under **EXTREME** tension.
- Disable **ALL** locks and remove **ALL** ropes connected to garage door **BEFORE** installing and operating garage door opener to avoid entanglement.

## CAUTION

To prevent damage to garage door and opener:

- **ALWAYS** disable locks before installing and operating the opener.
- **ONLY** operate garage door opener at 120V, 60 Hz to avoid malfunction and damage.

## Tools needed

During assembly, installation and adjustment of the opener, instructions will call for hand tools as illustrated below.

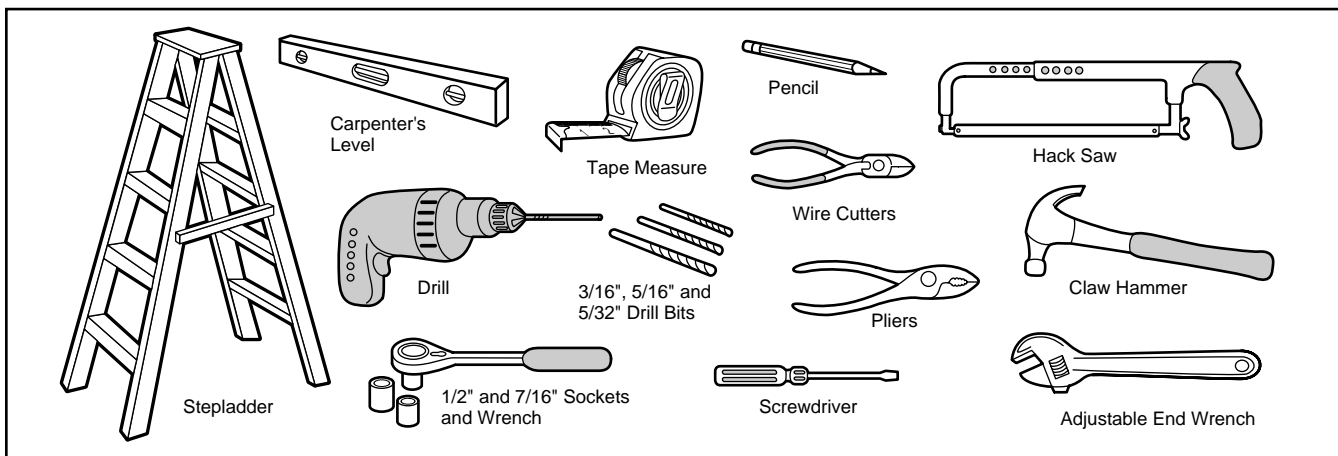

# Planning

Identify the type and height of your garage door. Survey your garage area to see if any of the conditions below apply to your installation. Additional materials may be required. You may find it helpful to refer back to this page as you proceed with the installation of your opener.

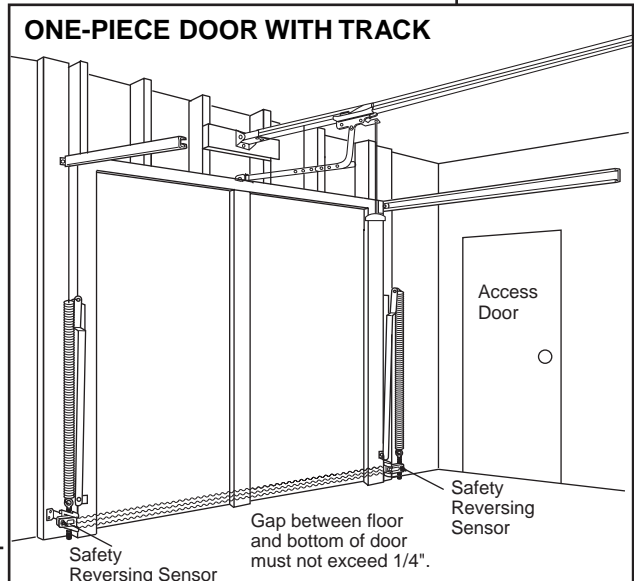
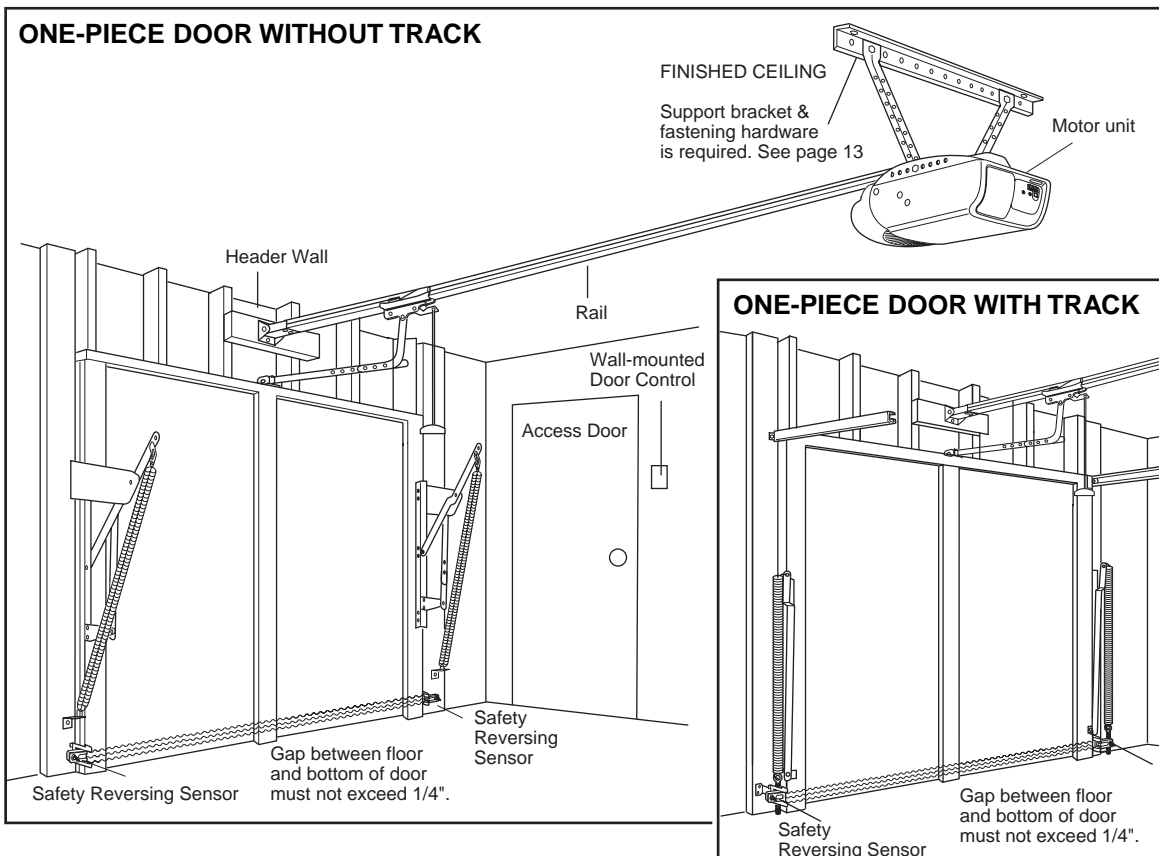
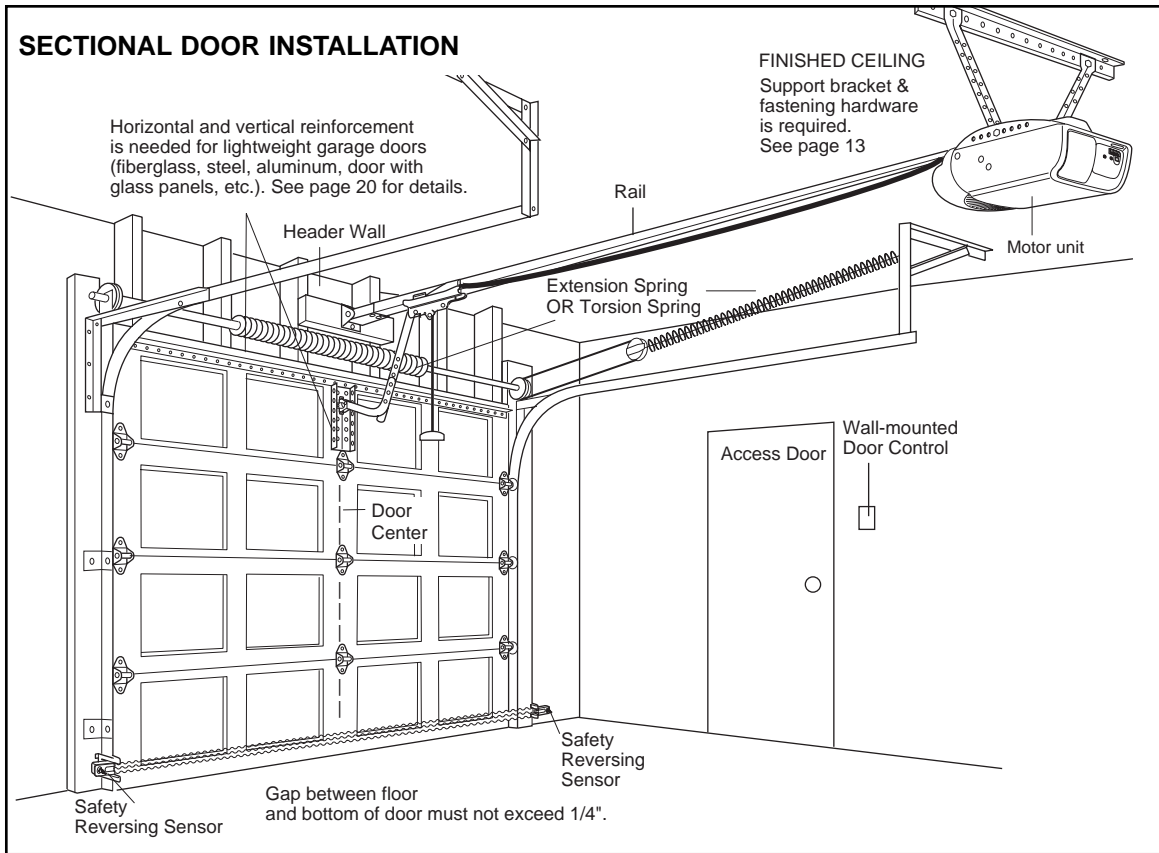

## Carton Inventory

Your garage door opener is packaged in two cartons which contain the motor unit and the parts illustrated below. Note that accessories will depend on the model purchased. If anything is missing, carefully

check the packing material. Parts may be stuck in the foam. KEEP THE FOAM INTACT (see page 6.)

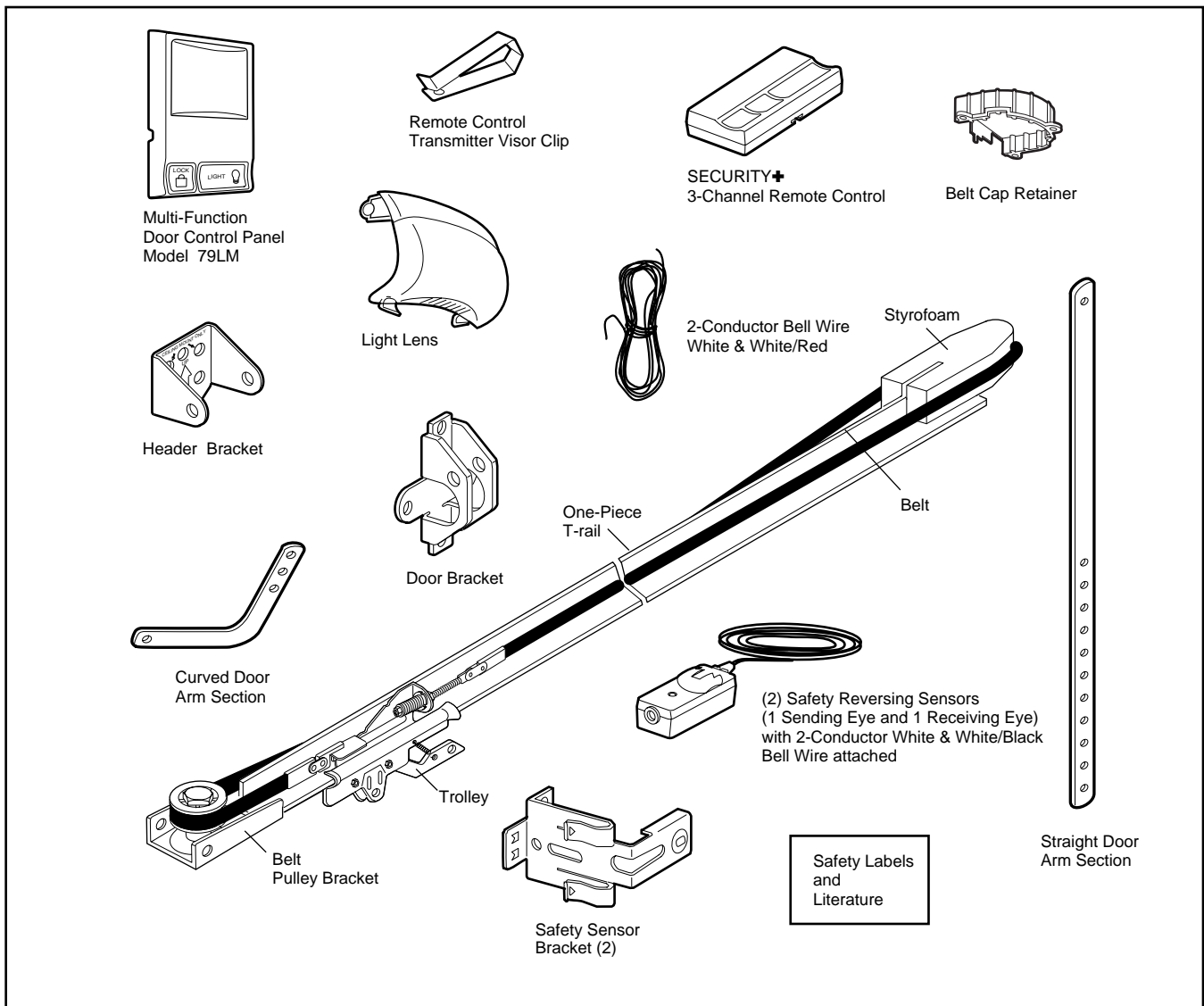

## Hardware Inventory

### INSTALLATION HARDWARE

Hex Screw #8 x 3/8" (3)

Hex Bolt 5/16"-18 x 7/8" (4)

Lag Screw 5/16"-9 x 1-5/8" (2)

Lag Screw 5/16"-18 x 1-7/8" (2)

Self-Threading Screw 1/4"-14x5/8" (2)

Clevis Pin 5/16" x 2-3/4" (1)

Clevis Pin 5/16" x 1-1/4" (1)

Clevis Pin 5/16" x 1" (1)

Nut 5/16" - 18 (4)

Lock Washer 5/16" (4)

Screw 6AB x 1-1/4" (2)

Screw 6-32 x 1" (2)

Insulated Staples (30)

Ring Fastener (3)

Handle

Dry Wall Anchors (2)

Rope

Carriage Bolts 1/4" - 20 x 1/2" (2)

Wing Nut 1/4" x 20 (2)

## ASSEMBLY STEP 1

### Attach the T-Rail to the Motor Unit

To avoid installation difficulties, do not run the garage door opener until instructed to do so.

- Remove the two washered bolts mounted in top of motor unit.
- Align T-rail and styrofoam over sprocket. Cut tape from T-rail, belt and styrofoam.
- REMOVE STYROFOAM.
- Insert both washered bolts through the T-rail into the motor unit. Tighten bolts securely.

**Use only these bolts! Use of any other bolts will cause serious damage to door opener.**

- Position belt over the motor unit sprocket.

## CAUTION

To avoid serious damage to opener, ONLY use bolts mounted in top of motor unit.

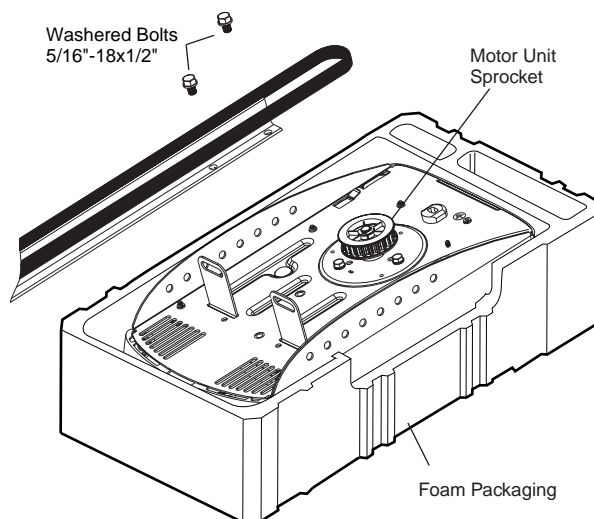

## ASSEMBLY STEP 2

### Set the Belt Tension

- By hand, thread the spring trolley nut on the threaded shaft until it is finger tight against the trolley (Figure 1). Do not use any tools.
- Insert a screwdriver tip into one of the nut ring slots and brace it firmly against the trolley (Figure 2).

Figure 1

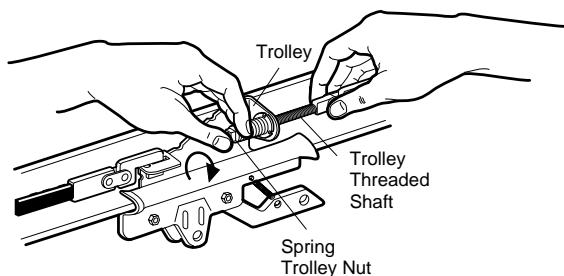
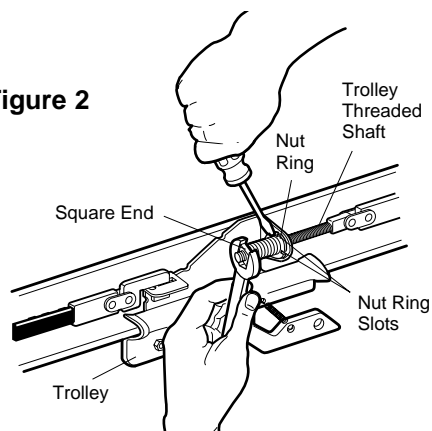

Figure 2



- Place a 7/16" open end wrench on the square end. Rotate about 1/4 turn until the spring releases and snaps the nut ring against the trolley (Figure 3).

This extends the spring for optimum belt tension.

Figure 3

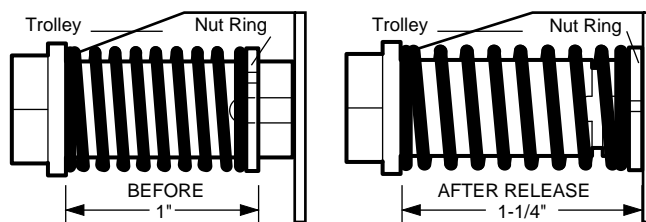

## ASSEMBLY STEP 3

### Attach the Belt Cap Retainer

- Position the belt cap retainer over the opener sprocket so the two holes in cap align with the two holes in mounting plate. Attach with #8x3/8" hex screws provided.

*You have now finished assembling your garage door opener. Please read the following warnings before proceeding to the installation section.*

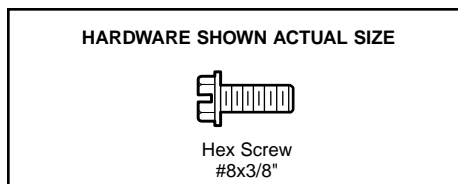

**⚠ WARNING**

To avoid possible SERIOUS INJURY to fingers from moving garage door opener:

- ALWAYS keep hand clear of sprocket while operating opener.
- Securely attach sprocket cover before operating.

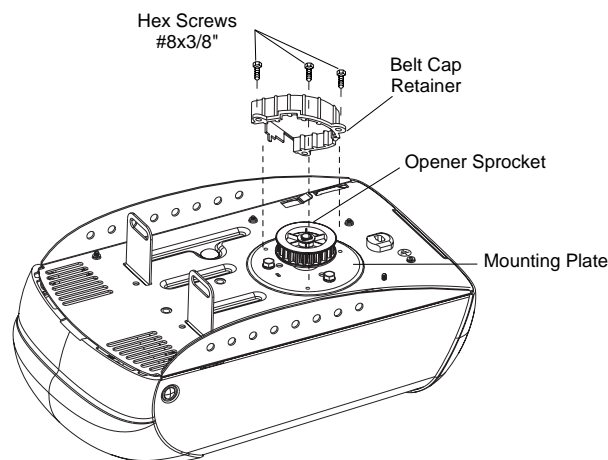

## INSTALLATION

### IMPORTANT INSTALLATION INSTRUCTIONS

#### ⚠ WARNING

#### To reduce the risk of severe injury or death:

1. READ AND FOLLOW ALL INSTALLATION WARNINGS AND INSTRUCTIONS.
2. Install garage door opener only on properly balanced and lubricated garage door. An improperly balanced door may not reverse when required and could result in severe injury or death.
3. All repairs to cables, spring assemblies and other hardware MUST be made by a trained door systems technician before installing opener.
4. Disable all locks and remove all ropes connected to garage door before installing opener to avoid entanglement.
5. Install garage door opener 7 feet or more above floor.
6. Mount emergency release handle 6 feet above floor.
7. NEVER connect garage door opener to power source until instructed to do so.
8. NEVER wear watches, rings or loose clothing while installing or servicing opener. They could be caught in garage door or opener mechanisms.
9. Install wall-mounted garage door control:
  - within sight of the garage door
  - out of reach of children at minimum height of 5 feet
  - away from all moving parts of the door.
10. Place entrapment warning label on wall next to garage door control.
11. Place manual release/safety reverse test label in plain view on inside of garage door.
12. Upon completion of installation, test safety reversal system. Door MUST reverse on contact with a one-inch high object (or a 2x4 laid flat) on the floor.

# INSTALLATION STEP 1

## Determine the Header Bracket Location

### **⚠ WARNING**

To prevent possible **SERIOUS INJURY** or **DEATH**:

- Header bracket **MUST** be **RIGIDLY** fastened to structural support on header wall or ceiling, otherwise garage door might not reverse when required. **DO NOT** install header bracket over drywall.
- Concrete anchors **MUST** be used if mounting header bracket or 2x4 into masonry.
- **NEVER** try to loosen, move or adjust garage door, springs, cables, pulleys, brackets, or their hardware, all of which are under **EXTREME** tension.
- **ALWAYS** call a trained door systems technician if garage door binds, sticks, or is out of balance. An unbalanced garage door might not reverse when required.

Installation procedures vary according to garage door types. Follow the instructions which apply to your door.

### SECTIONAL DOOR AND ONE-PIECE DOOR WITH TRACK

1. Close the door and mark the inside vertical centerline of the garage door.
2. Extend the line onto the header wall above the door.

**You can fasten the header bracket within 4 feet of the left or right of the door center only if a torsion spring or center bearing plate is in the way; or you can attach it to the ceiling (see page 10) when clearance is minimal. (It may be mounted on the wall upside down if necessary, to gain approximately 1/2".)**

If you need to install the header bracket on a 2x4 (on wall or ceiling), use lag screws (not provided) to securely fasten the 2x4 to structural supports as shown here and on page 10.

3. Open your door to the highest point of travel as shown. Draw an intersecting horizontal line on the header wall 2" above the high point. This height will provide travel clearance for the top edge of the door.

**Proceed to Step 2, page 10.**

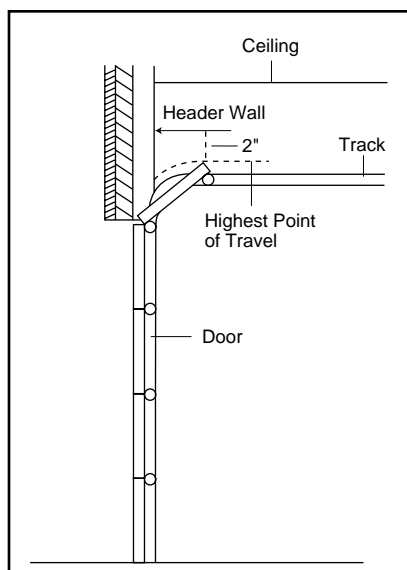
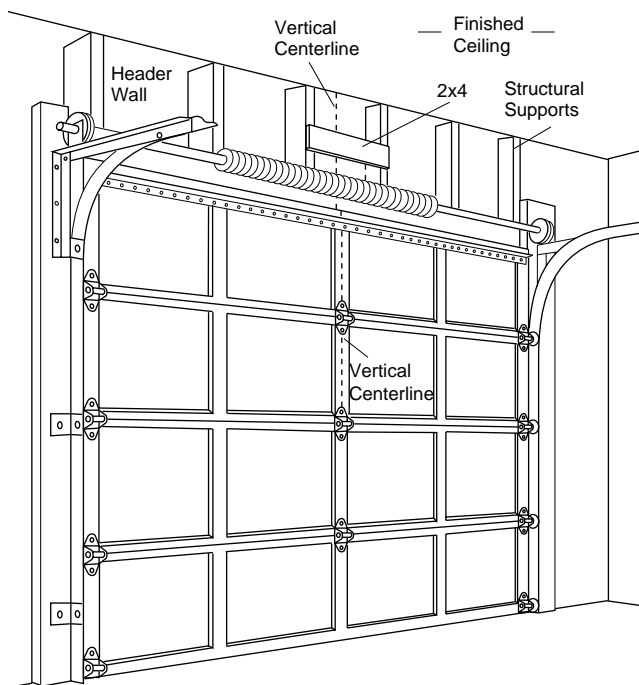

**Sectional door with curved track**

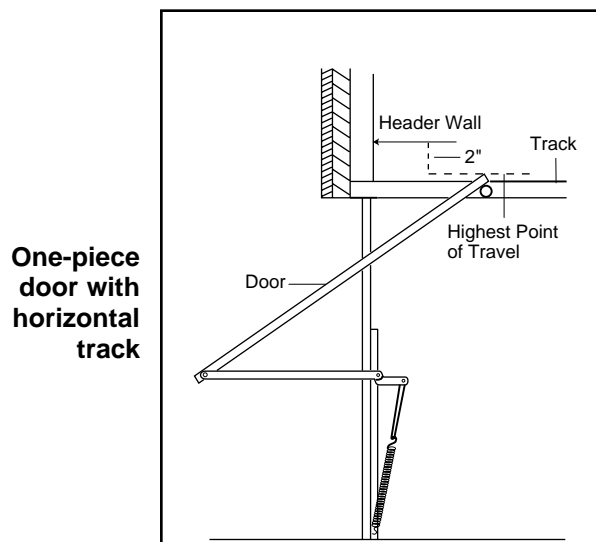

**One-piece door with horizontal track**



## ONE-PIECE DOOR WITHOUT TRACK

1. Close the door and mark the inside vertical centerline of your garage door. Extend the line onto the header wall above door, as shown.

If headroom clearance is minimal, you can install the header bracket on the ceiling. See page 10.

If you need to install the header bracket on a 2x4 (on wall or ceiling), use lag screws (not provided) to securely fasten the 2x4 to structural supports as shown. If installing into masonry, use concrete anchors (not provided).

2. Open your door to the highest point of travel as shown. Measure the distance from the top of the door to the floor. Subtract the actual height of the door. Add 8" to the remainder. (See Example).

3. Close the door and draw an intersecting horizontal line on the header wall at the determined height.

**NOTE:** If the total number of inches exceeds the height available in your garage, use the maximum height possible, or refer to page 10 for ceiling installation.

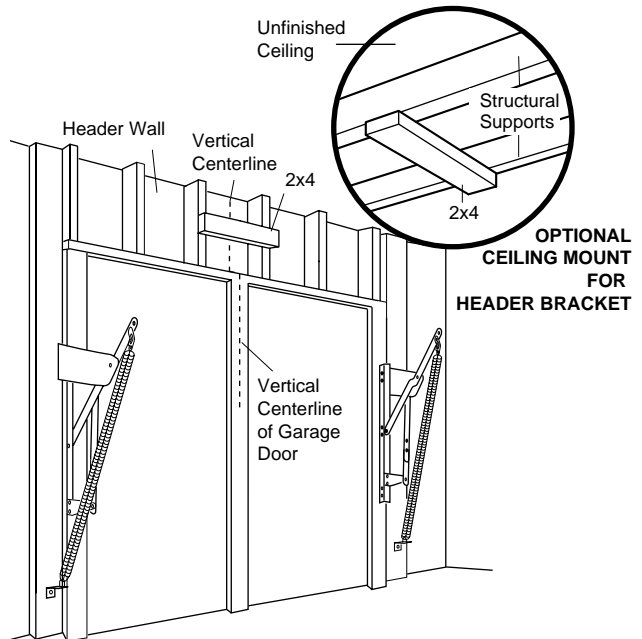

### EXAMPLE

Distance from top of door (at highest point of travel) to floor .....	92"
Actual height of door .....	-88"
Remainder .....	4"
Add .....	+8"
Bracket height on header wall .....	=12"

(Measure UP from top of CLOSED door.)

**Proceed to Step 2, page 10.**

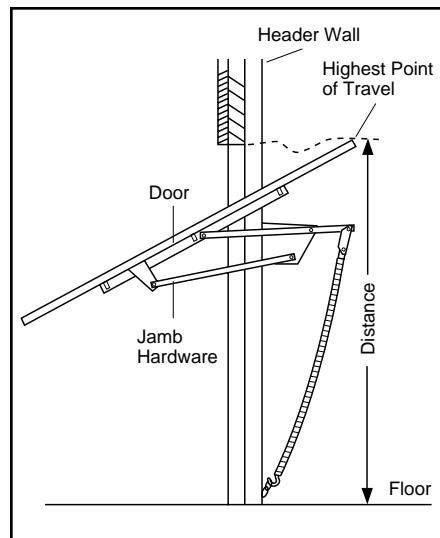

**One-piece door without track:  
jamb hardware**

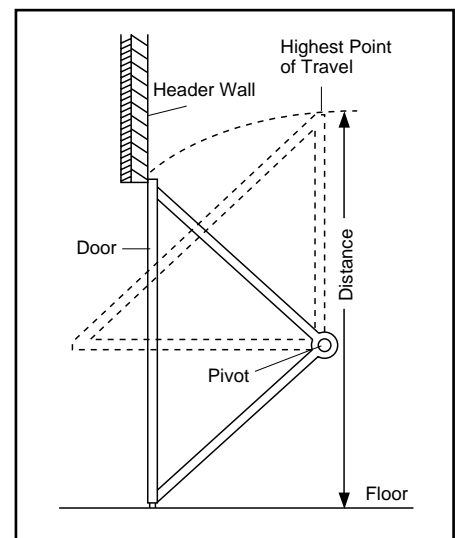

**One-piece door without track:  
pivot hardware**

## INSTALLATION STEP 2

### Install the Header Bracket

You can attach the header bracket either to the wall above the garage door, or to the ceiling. Follow the instructions which will work best for your particular requirements. **Do not install the header bracket over drywall. If installing into masonry, use concrete anchors (not provided).**

#### WALL HEADER BRACKET INSTALLATION

- Center the bracket on the vertical centerline with the bottom edge of the bracket on the horizontal line as shown (with the arrow pointing toward the ceiling).
- Mark the vertical set of bracket holes (do not use the holes designated for ceiling mount). Drill 3/16" pilot holes and fasten the bracket securely to a structural support with the hardware provided.

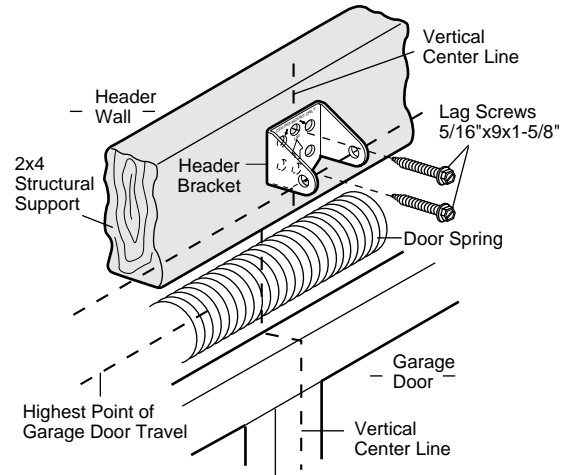
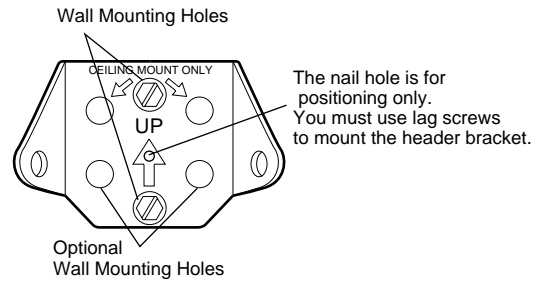
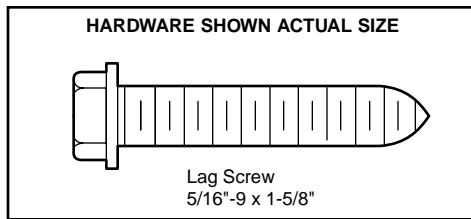

#### CEILING HEADER BRACKET INSTALLATION

- Extend the vertical centerline onto the ceiling as shown.
- Center the bracket on the vertical mark, no more than 6" from the wall. Make sure the arrow is pointing toward the wall. The bracket can be mounted flush against the ceiling when clearance is minimal.
- Mark the side holes. Drill 3/16" pilot holes and fasten bracket securely to a structural support with the hardware provided.

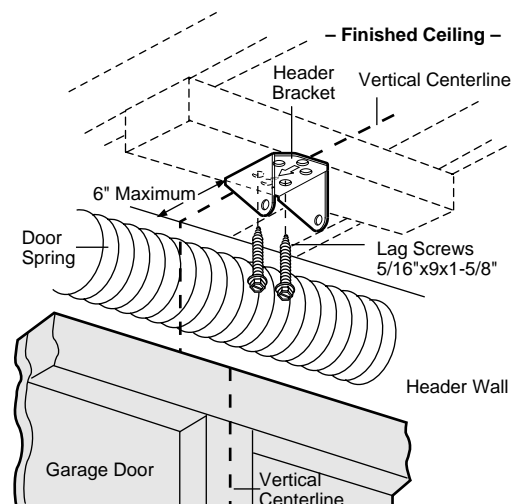
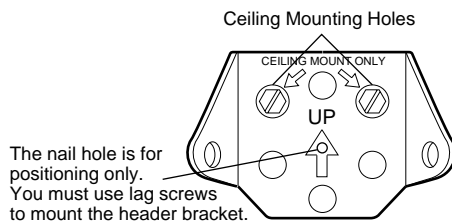

## INSTALLATION STEP 3

### Attach the T-Rail to the Header Bracket

- Position the opener on the garage floor below the header bracket. Use packing material as a protective base. **NOTE:** If the door spring is in the way you'll need help. Have someone hold the opener securely on a temporary support to allow the rail to clear the spring.
- Position the rail bracket against the header bracket.
- Align the bracket holes and join with a clevis pin as shown.
- Insert a ring fastener to secure.

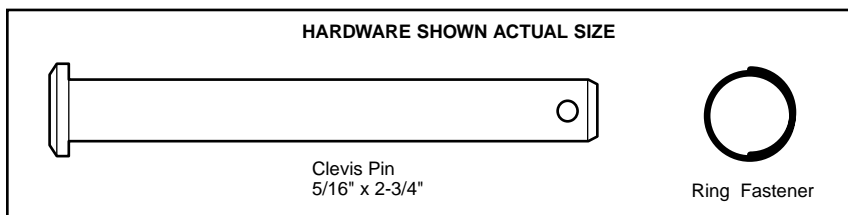
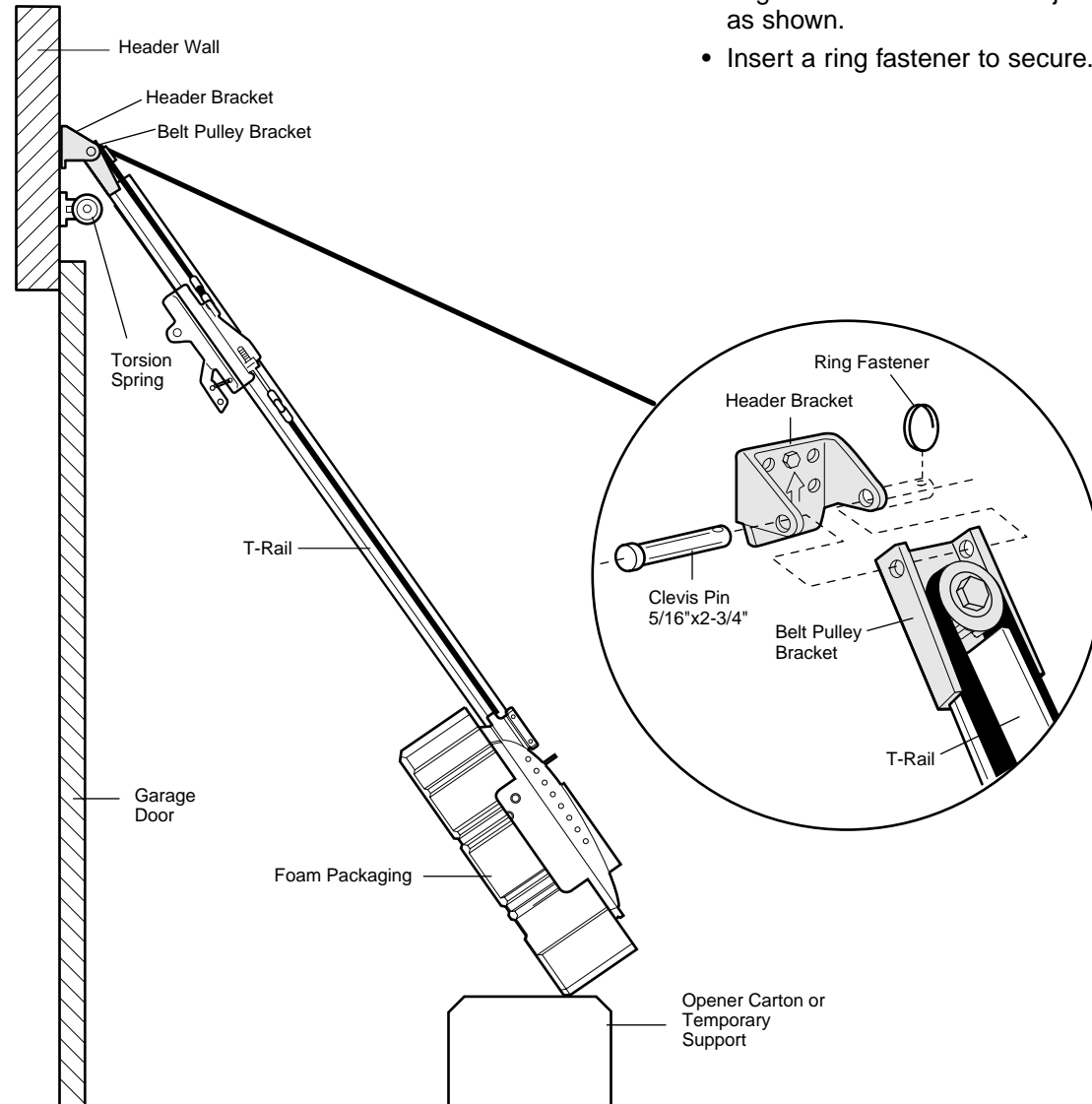

## INSTALLATION STEP 4

### Position the Opener

Follow instructions which apply to your door type as illustrated.

#### SECTIONAL DOOR OR ONE-PIECE DOOR WITH TRACK

A 2x4 laid flat is convenient for setting an ideal door-to-rail distance.

- Raise the opener onto a stepladder. You will need help at this point if the ladder is not tall enough.
- Open the door all the way and place a 2x4 laid flat on the top section beneath the rail.
- If the top panel hits the trolley when you raise the door, pull down on the trolley release arm to disconnect inner and outer sections. Slide the outer trolley toward the motor unit. The trolley can remain disconnected until Step 12 is completed.

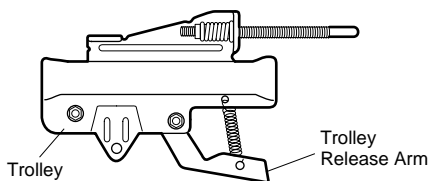

<h2>CAUTION</h2> <p>To prevent damage to garage door, rest garage door opener rail on 2x4 placed on top section of door.</p>
--

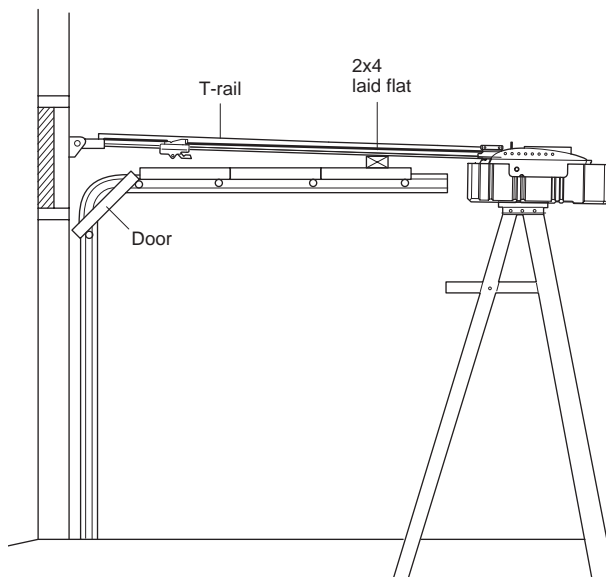

#### ONE-PIECE DOOR WITHOUT TRACK

- With the door fully open and parallel to the floor, measure the distance from the floor to the top of the door.
- Using a stepladder as a support, raise the opener to this height.
- The top of the door should be level with the top of the motor unit. Do not position the opener more than 2" above this point.

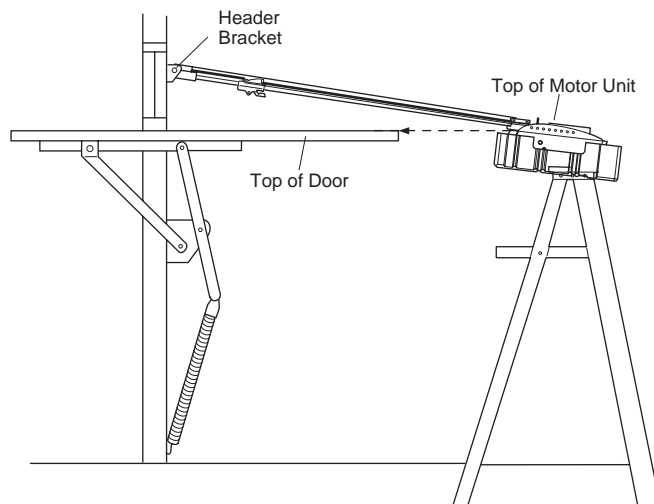

## INSTALLATION STEP 5

### Hang the Opener

Three representative installations are shown. Yours may be different. Hanging brackets should be angled, Figure 1, to provide rigid support. On finished ceilings, Figure 2, attach a sturdy metal bracket to structural supports before installing the opener. This bracket and fastening hardware are not provided.

Existing brackets from a previous installation may be fastened to the sides of the motor unit as in Figures 1 and 2, or to the mounting tabs as shown in Figure 3. Then continue with step 5 below.

1. Remove from packaging. Measure the distance from each side of the motor unit to the structural support.
2. Cut both pieces of the hanging bracket to required lengths.
3. Drill  $\frac{3}{16}$ " pilot holes in the structural supports.
4. Attach one end of each bracket to a support with  $\frac{5}{16}$ "-18x1-7/8" lag screws.
5. Fasten the opener to the hanging brackets with  $\frac{5}{16}$ "-18x7/8" hex bolts, lock washers and nuts.
6. Check to make sure the rail is centered over the door (or in line with the header bracket if the bracket is not centered above the door).
7. Remove the 2x4. Operate the door manually. If the door hits the rail, raise the header bracket.
8. Grease the top and underside of the rail surface where the trolley slides with rail grease.

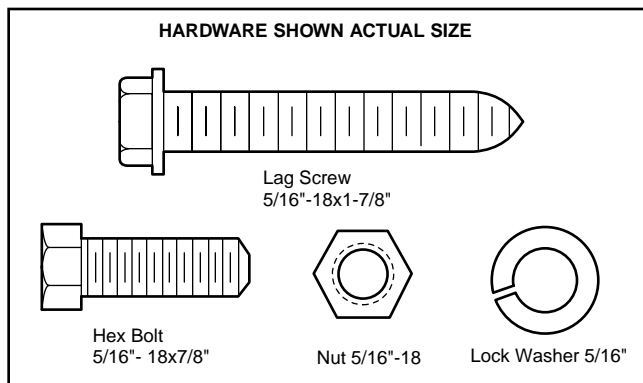

## ⚠ WARNING

To avoid possible **SERIOUS INJURY** from a falling garage door opener, fasten it **SECURELY** to structural supports of the garage. Concrete anchors **MUST** be used if installing any brackets into masonry.

Figure 1

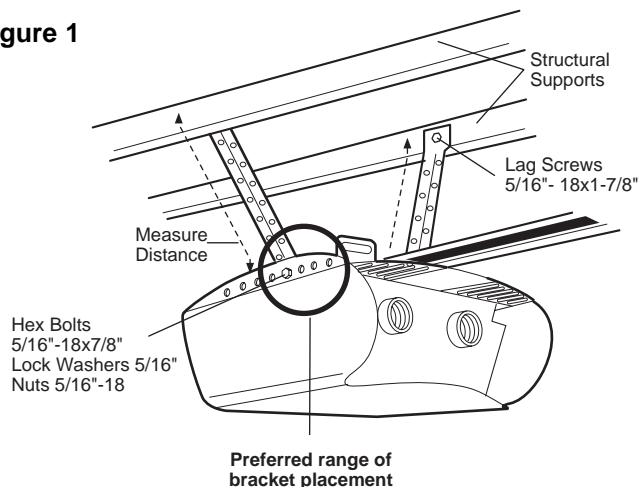

Figure 2

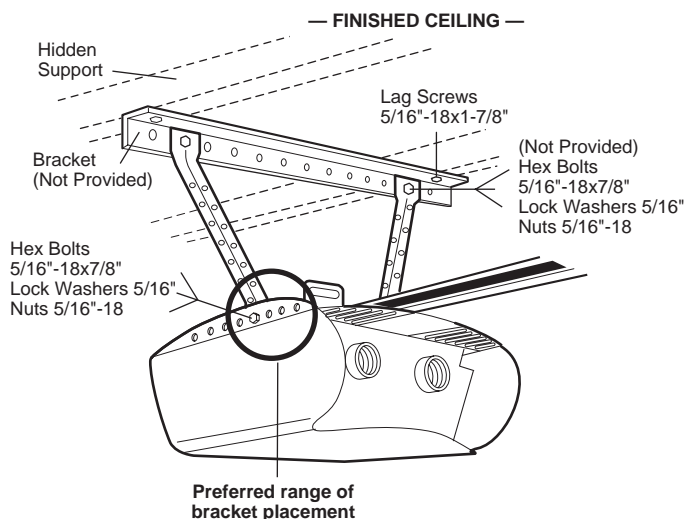
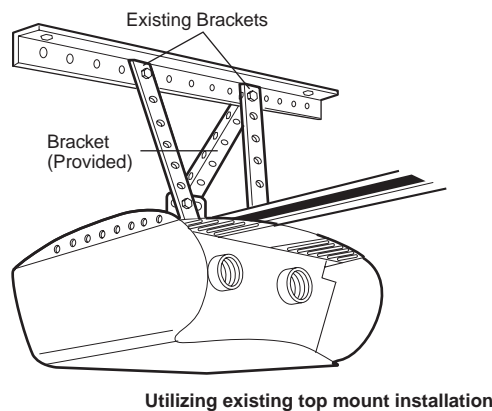

Figure 3



## INSTALLATION STEP 6

### Install the Door Control

Locate door control within sight of the door at a minimum height of 5 feet where small children cannot reach, and away from moving parts of the door and door hardware. The installation surface must be smooth and flat. If installing into drywall (Figure 1), drill 5/32" holes and use anchors provided. For pre-wired installations (as in new home construction) it may be mounted to a single gang box (Figure 2).

**NOTE:** After installation, a green or amber indicator light behind the cover will indicate proper connection. If not lit, the Lock and Light features will not function (reverse wires to correct).

- Strip 7/16" of insulation from one end of bell wire and connect to the two screw terminals on back of door control by color: white wire to WHT and white/red wire to the RED (Figure 3).
- Remove white cover by gently prying on a side corner near the top of the cover with a small flat head screwdriver (Figure 4). Fasten with 6ABx1-1/4" self-tapping screws (drywall installation) or 6-32x1" machine screws (into gang box) as follows:
  - Drill and install bottom screw, allowing 1/8" to protrude above wall surface.
  - Position bottom of door control on screw head and slide down to secure. Adjust screw for snug fit.
  - Install top screw with care to avoid cracking plastic housing. **Do not overtighten.**
  - Insert bottom tabs and snap on cover. (To remove cover after mounting, gently pry on a side corner near the top of the white cover with paper clip or small flat head screwdriver.)

**NOTE:** The push bar may stick if the door control is not mounted on a smooth surface. If a click is not heard when pressing the push bar, loosen the two mounting screws or relocate the door control to a smoother surface.

- (Standard installation only)** Run bell wire up wall and across ceiling to motor unit. Use insulated staples to secure wire in several places. Do not pierce wire with a staple, creating a short or open circuit.
- Strip 7/16" of insulation from end of bell wire. Connect bell wire to the quick-connect terminals as follows: white to white and white/red to red (Figure 5).
- Use tacks or staples to permanently attach entrapment warning label to wall near door control, and manual release/safety reverse test label in a prominent location on inside of garage door.

**NOTE:** DO NOT connect the power and operate the opener at this time. The trolley will travel to the full open position but will not return to the close position until the sensor beam is connected and properly aligned. See Safety Reversing Sensor Instructions beginning on page 17.

## ⚠️ WARNING

To prevent possible SERIOUS INJURY or DEATH from electrocution:

- Be sure power is not connected BEFORE installing door control.
- Connect ONLY to 24 VOLT low voltage wires.

To prevent possible SERIOUS INJURY or DEATH from a closing garage door:

- Install door control within sight of garage door, out of reach of children at a minimum height of 5 feet, and away from all moving parts of door.
- NEVER permit children to operate or play with door control push buttons or remote control transmitters.
- Activate door ONLY when it can be seen clearly, is properly adjusted, and there are no obstructions to door travel.
- ALWAYS keep garage door in sight until completely closed. NEVER permit anyone to cross path of closing garage door.

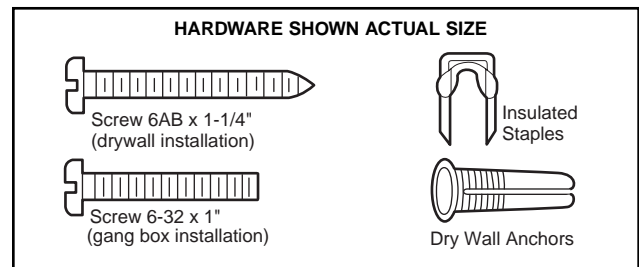

Figure 1 STANDARD INSTALLATION

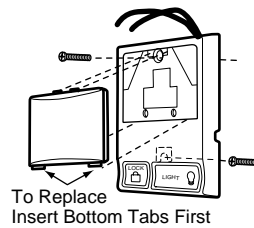

Figure 2 PRE-WIRED INSTALLATION

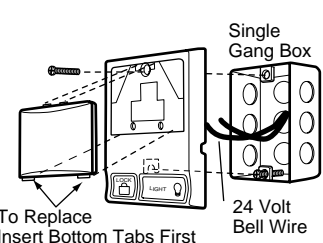

Figure 3 MULTI-FUNCTION DOOR CONTROL (BACK)

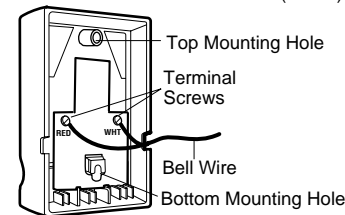

Figure 4 REMOVE COVER

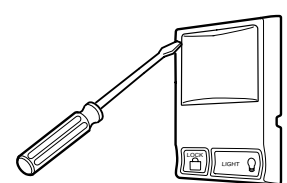
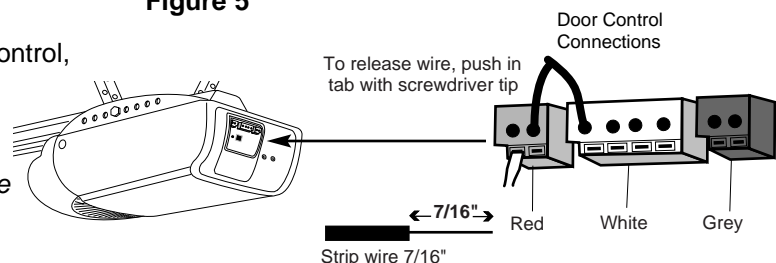

Figure 5



## INSTALLATION STEP 7

### Install the Lights and Lens

Press the release tabs on both sides of lens. Gently rotate lens back and downward until the lens hinge is in the fully open position. Do not remove the lens.

- Install up to a 100 watt maximum light bulb in each socket. The lights will turn ON and remain lit for approximately 4-1/2 minutes when power is connected. Then the lights will turn OFF.
- Reverse the procedure to close the lens.
- If the bulbs burn out prematurely due to vibration, replace with a Garage Door Opener bulb.

**NOTE:** Use only standard light bulbs. The use of short neck or speciality light bulbs may overheat the endpanel or light socket.

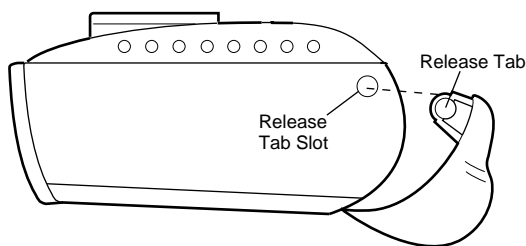
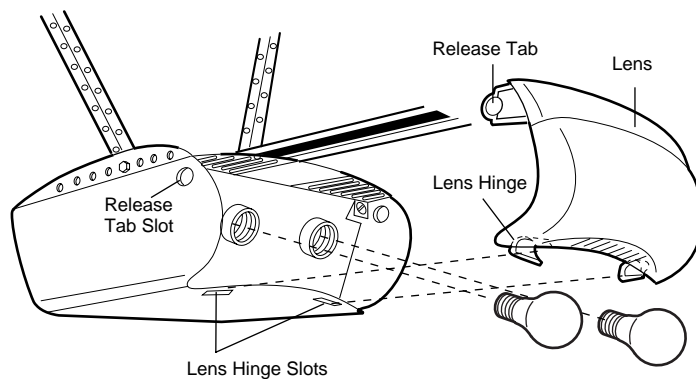

## INSTALLATION STEP 8

### Attach the Emergency Release Rope and Handle

- Thread one end of the rope through the hole in the top of the red handle so "NOTICE" reads right side up as shown. Secure with an overhand knot at least 1" from the end of the rope to prevent slipping.
- Thread the other end of the rope through the hole in the release arm of the outer trolley.
- Adjust rope length so the handle is 6 feet above the floor. Secure with an overhand knot.

**NOTE:** If it is necessary to cut the rope, heat seal the cut end with a match or lighter to prevent unraveling.

<b>⚠ WARNING</b>
<ul style="list-style-type: none"><li>• To prevent possible <b>SERIOUS INJURY</b> or <b>DEATH</b> from a falling garage door:<ul style="list-style-type: none"><li>– If possible, use emergency release handle to disengage trolley <b>ONLY</b> when garage door is <b>CLOSED</b>. Weak or broken springs or unbalanced door could result in an open door falling rapidly and/or unexpectedly.</li><li>– <b>NEVER</b> use emergency release handle unless garage doorway is clear of persons and obstructions.</li></ul></li><li>• <b>NEVER</b> use handle to pull door open or closed. If rope knot becomes untied, you could fall.</li></ul>

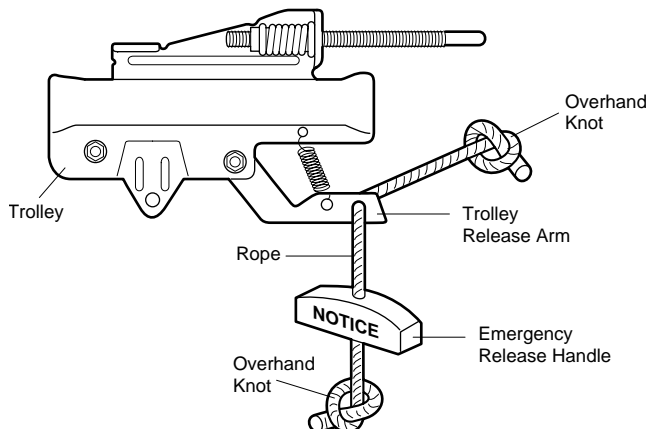

## INSTALLATION STEP 9

### Electrical Requirements

To avoid installation difficulties, do not run the opener at this time.

To reduce the risk of electric shock, your garage door opener has a grounding type plug with a third grounding pin. This plug will only fit into a grounding type outlet. If the plug doesn't fit into the outlet you have, contact a qualified electrician to install the proper outlet.

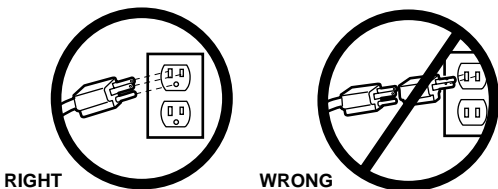

If permanent wiring is required by your local code, refer to the following procedure.

To make a permanent connection through the 7/8" hole in the top of the motor unit (according to local code):

- Remove the motor unit cover screws and set the cover aside.
- Remove the attached 3-prong cord.
- Connect the black (line) wire to the screw on the brass terminal; the white (neutral) wire to the screw on the silver terminal; and the ground wire to the green ground screw. **The opener must be grounded.**
- Reinstall the cover.

To avoid installation difficulties, do not run the opener at this time.

## WARNING

To prevent possible SERIOUS INJURY or DEATH from electrocution or fire:

- Be sure power is not connected to the opener, and disconnect power to circuit BEFORE removing cover to establish permanent wiring connection.
- Garage door installation and wiring MUST be in compliance with all local electrical and building codes.
- NEVER use an extension cord, 2-wire adapter, or change plug in any way to make it fit outlet. Be sure the opener is grounded.

### Permanent Wiring Connection

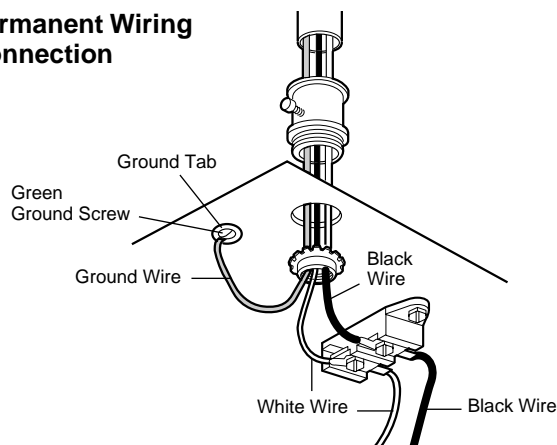



## INSTALLATION STEP 10

### Install the Protector System®

The safety reversing sensor *must* be connected and aligned correctly before the garage door opener will move in the down direction. This is a required safety device and cannot be disabled.

#### IMPORTANT INFORMATION ABOUT THE SAFETY REVERSING SENSOR

When properly connected and aligned, the safety reversing sensor will detect an obstacle in the path of its electronic beam. The sending eye (with an orange indicator light) transmits an invisible light beam to the receiving eye (with a green indicator light). If an obstruction breaks the light beam while the door is closing, the door will stop and reverse to full open position, and the opener lights will flash 10 times.

The units must be installed inside the garage so that the sending and receiving eyes face each other across the door, no more than 6" above the floor. Either can be installed on the left or right of the door as long as the sun never shines directly into the receiving eye lens.

The mounting brackets are designed to clip onto the track of sectional garage doors without additional hardware.

## ⚠ WARNING

- Be sure power is not connected to the garage door opener BEFORE installing the safety reversing sensor.
- To prevent SERIOUS INJURY or DEATH from a closing garage door:
  - Correctly connect and align the safety reversing sensor. This required safety device MUST NOT be disabled.
  - Install the safety reversing sensor so beam is NO HIGHER than 6" above garage floor.

If it is necessary to mount the units on the wall, the brackets must be securely fastened to a solid surface such as the wall framing. Extension brackets (see accessories) are available if needed. If installing in masonry construction, add a piece of wood at each location to avoid drilling extra holes in masonry if repositioning is necessary.

The invisible light beam path must be unobstructed. No part of the garage door (or door tracks, springs, hinges, rollers or other hardware) may interrupt the beam while the door is closing.

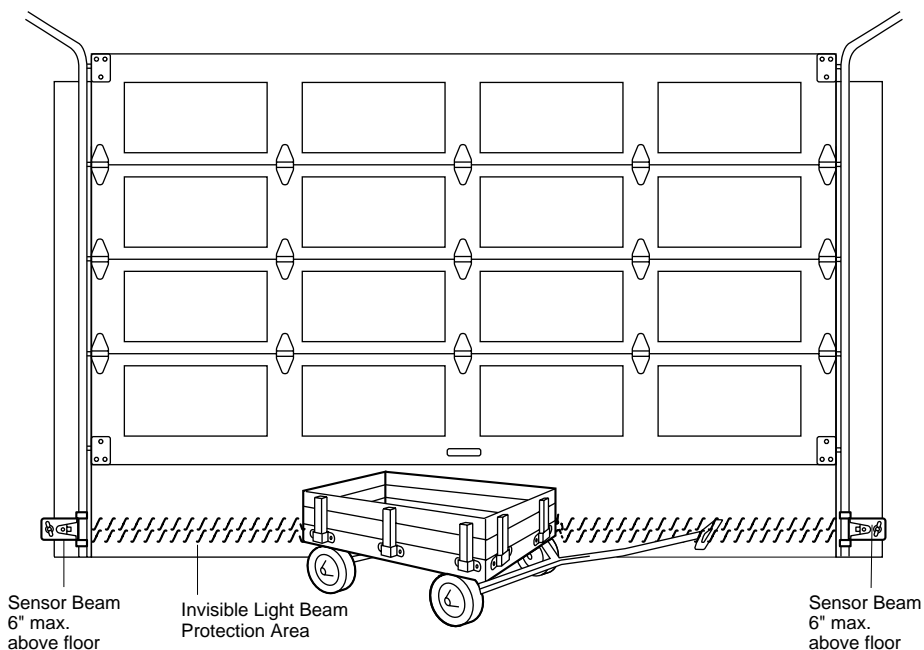

Facing the door from inside the garage

## INSTALLING THE BRACKETS

**Be sure power to the opener is disconnected.**

Install and align the brackets so the sensors will face each other across the garage door, with the beam no higher than 6" above the floor. They may be installed in one of three ways, as follows.

### **Garage door track installation (preferred):**

- Slip the curved arms over the rounded edge of each door track, with the curved arms facing the door. Snap into place against the side of the track. It should lie flush, with the lip hugging the back edge of the track, as shown in Figure 1.

If your door track will not support the bracket securely, wall installation is recommended.

### **Wall installation:**

- Place the bracket against the wall with curved arms facing the door. Be sure there is enough clearance for the sensor beam to be unobstructed.
- If additional depth is needed, an extension bracket (see Accessories) or wood blocks can be used.
- Use bracket mounting holes as a template to locate and drill (2) 3/16" diameter pilot holes on the wall at each side of the door, no higher than 6" above the floor.
- Attach brackets to wall with lag screws (not provided).
- If using extension brackets or wood blocks, adjust right and left assemblies to the same distance out from the mounting surface. Make sure all door hardware obstructions are cleared.

### **Floor installation:**

- Use wood blocks or extension brackets (see Accessories) to elevate sensor brackets so the lenses will be no higher than 6" above the floor.
- Carefully measure and place right and left assemblies at the same distance out from the wall. Be sure all door hardware obstructions are cleared.
- Fasten to the floor with concrete anchors as shown.

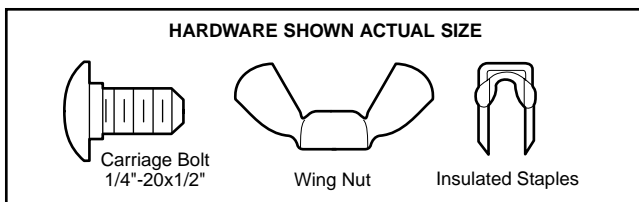

**Figure 1 Door Track Mount (Right Side)**

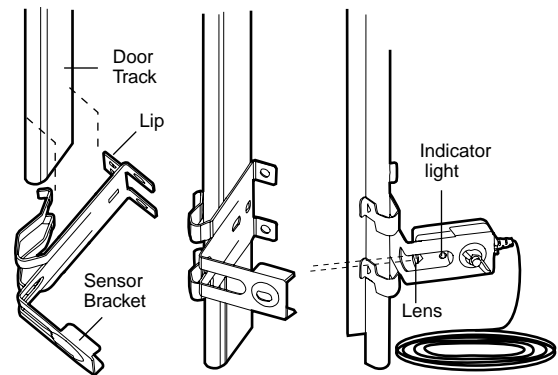

**Figure 2 Wall Mount (Right Side)**

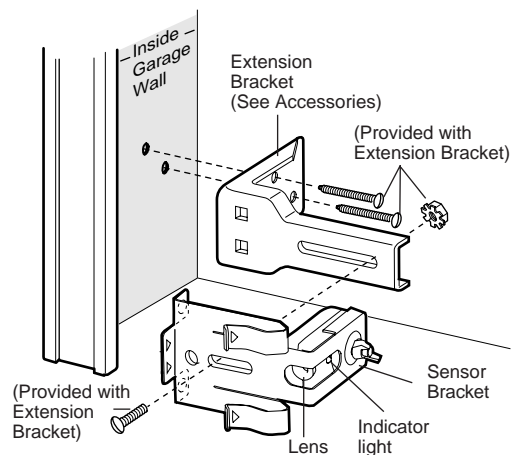

**Figure 3 Floor Mount (Right Side)**

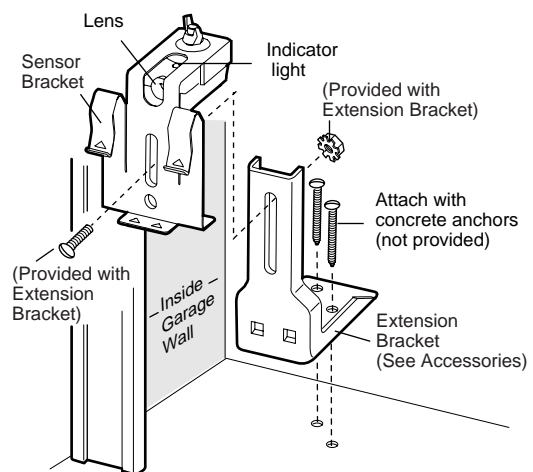

## MOUNTING AND WIRING THE SAFETY SENSORS

- Slide a 1/4"-20x1/2" carriage bolt head into the slot on each sensor. Use wing nuts to fasten sensors to brackets, with lenses pointing toward each other across the door. Be sure the lens is not obstructed by a bracket extension (Figure 4).
- Finger tighten the wing nuts.
- Run the wires from both sensors to the opener. Use insulated staples to secure wire to wall and ceiling.
- Strip 7/16" of insulation from each set of wires. Separate white and white/black wires sufficiently to connect to the opener quick-connect terminals: white to white and white/black to grey (Figure 5).

## ALIGNING THE SAFETY SENSORS

- Plug in the opener. The indicator lights in both the sending and receiving eyes will *glow steadily* if wiring connections and alignment are correct. The *sending* eye orange indicator light will glow regardless of alignment or obstruction. If the green indicator light in the *receiving* eye is off, dim, or flickering (and the invisible light beam path is not obstructed), alignment is required.
- Loosen the sending eye wing nut and readjust, aiming directly at the receiving eye. Lock in place.
- Loosen the receiving eye wing nut and adjust sensor until it receives the sender's beam. When the green indicator light glows steadily, tighten the wing nut.

Figure 4

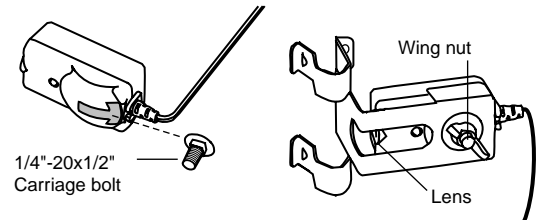

## TROUBLESHOOTING THE SAFETY SENSORS

1. If the sending eye indicator light does not glow steadily after installation, check for:
  - Electric power to the opener.
  - A short in the white or white/black wires. These can occur at staples, or at opener connections.
  - Incorrect wiring between sensors and opener.
  - A broken wire.
2. If the sending eye indicator light glows steadily but the receiving eye indicator light doesn't:
  - Check alignment.
  - Check for an open wire to the receiving eye.
3. If the receiving eye indicator light is dim, realign either sensor.

**NOTE:** When the invisible beam path is obstructed or misaligned while the door is closing, the door will reverse. If the door is already open, it will not close. The opener lights will blink 10 times. (If bulbs are not installed, 10 clicks can be heard.) See page 17.

Figure 5

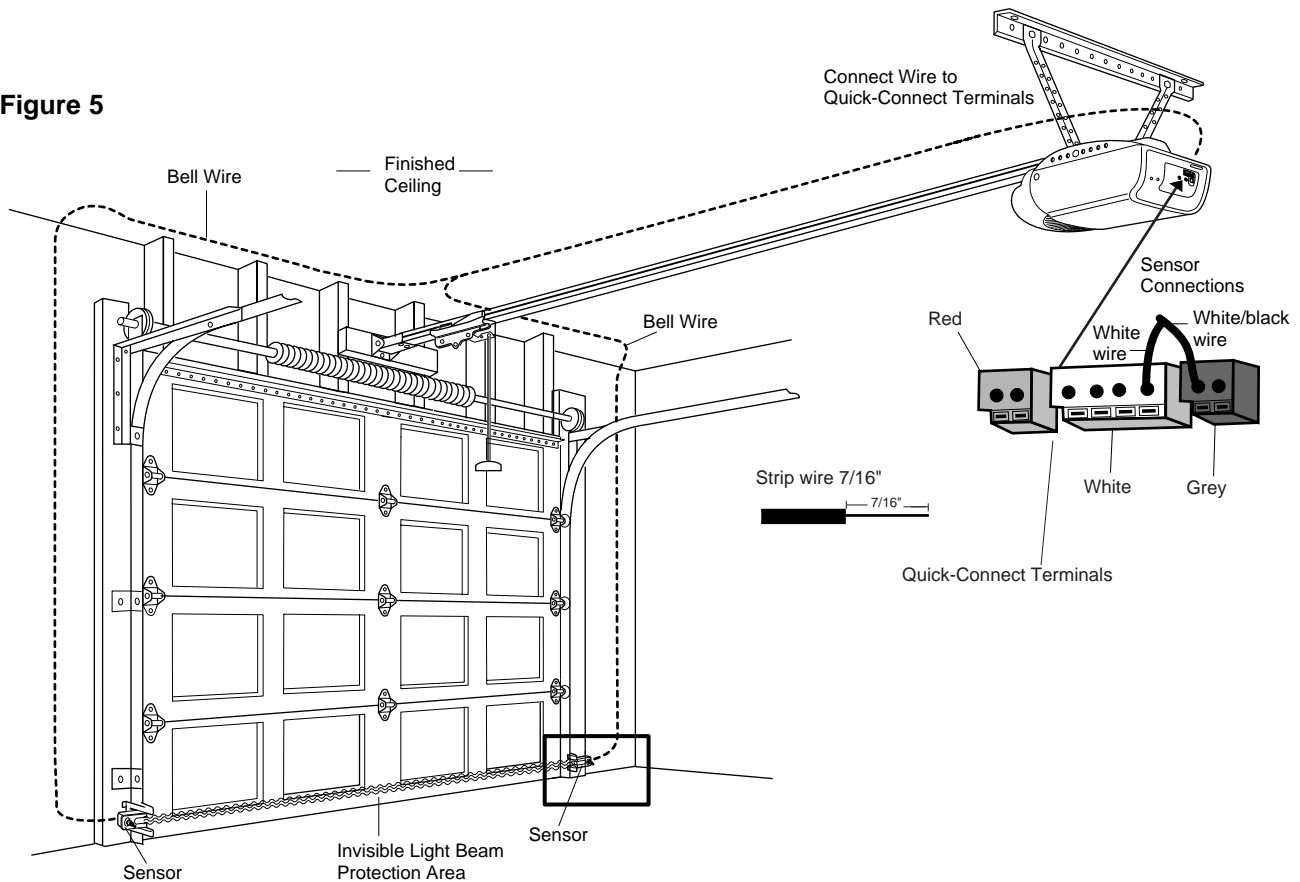

# INSTALLATION STEP 11

## Fasten the Door Bracket

Follow instructions which apply to your door type as illustrated below or on the following page.

**A horizontal reinforcement brace should be long enough to be secured to two or three vertical supports. A vertical reinforcement brace should cover the height of the top panel.**

Figure 1 shows one piece of angle iron as the horizontal brace. For the vertical brace, 2 pieces of angle iron are used to create a U-shaped support. The best solution is to check with your garage door manufacturer for an opener installation door reinforcement kit.

**NOTE:** Many door reinforcement kits provide for direct attachment of the clevis pin and door arm. In this case you will not need the door bracket; proceed to Step 12.

### SECTIONAL DOORS

1. Center the door bracket on the previously marked vertical centerline used for the header bracket installation. Note correct UP placement, as stamped inside the bracket.
2. Position the top edge of the bracket 2"-4" below the top edge of the door, OR directly below any structural support across the top of the door.
3. Mark, drill holes and install as follows, depending on your door's construction:

**Metal or light weight doors using a vertical angle iron brace between the door panel support and the door bracket:**

- Drill 3/16" fastening holes. Secure the door bracket using the two 1/4"-14x5/8" self-threading screws. (Figure 2A)
- Alternately, use two 5/16" bolts, lock washers and nuts (not provided). (Figure 2B)

**Metal, insulated or light weight factory reinforced doors:**

- Drill 3/16" fastening holes. Secure the door bracket using the self-threading screws (Figure 3).

**Wood Doors:**

- Use top and bottom or side to side door bracket holes. Drill 5/16" holes through the door and secure bracket with 5/16"x2" carriage bolts, lock washers and nuts (not provided). (Figure 4)

**NOTE:** The 1/4"-14x5/8" self-threading screws are not intended for use on wood doors.



## CAUTION

To prevent damage to garage door, reinforce inside of door with angle iron both vertically and horizontally.

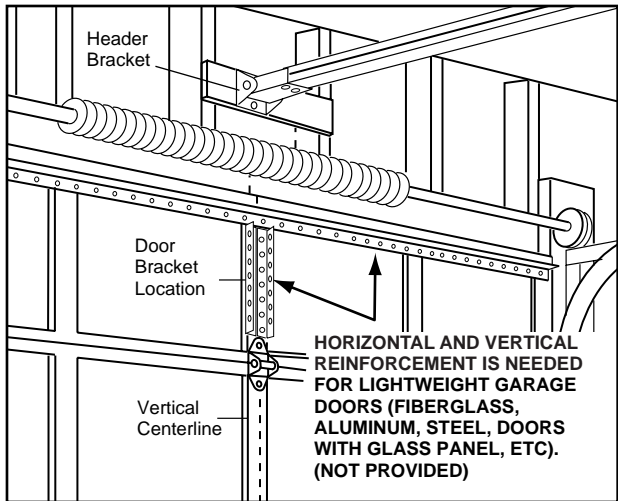

Figure 1

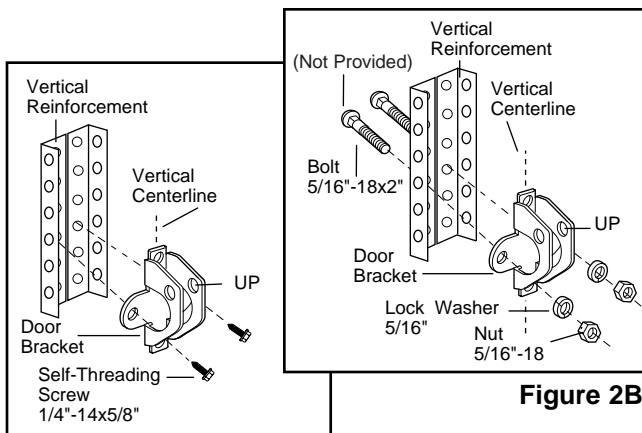

Figure 2A

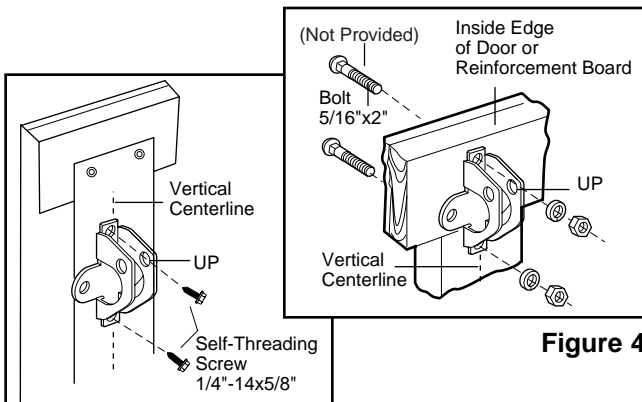

Figure 3

Figure 4

## ONE-PIECE DOORS

Please read and comply with the warnings and reinforcement instructions on the previous page. They apply to one-piece doors also.

- Center the door bracket on the top of the door, in line with the header bracket as shown. Mark either the left and right, or the top and bottom holes.
- **Metal Doors:** Drill 3/16" pilot holes and fasten the bracket with the 1/4"-14x5/8" self-threading screws provided.
- **Wood Doors:** Drill 5/16" holes and use 5/16"x2" carriage bolts, lock washers and nuts (not provided) or 5/16"x1-1/2" lag screws (not provided) depending on your installation needs.

**NOTE:** The door bracket may be installed on the top edge of the door if required for your installation. (Refer to the dotted line optional placement drawing.)

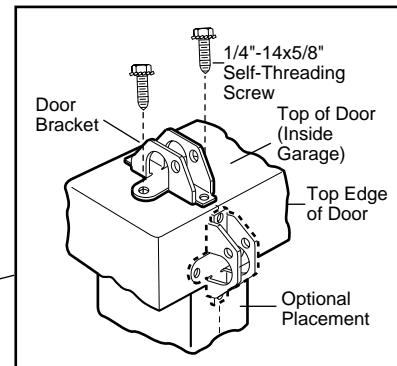
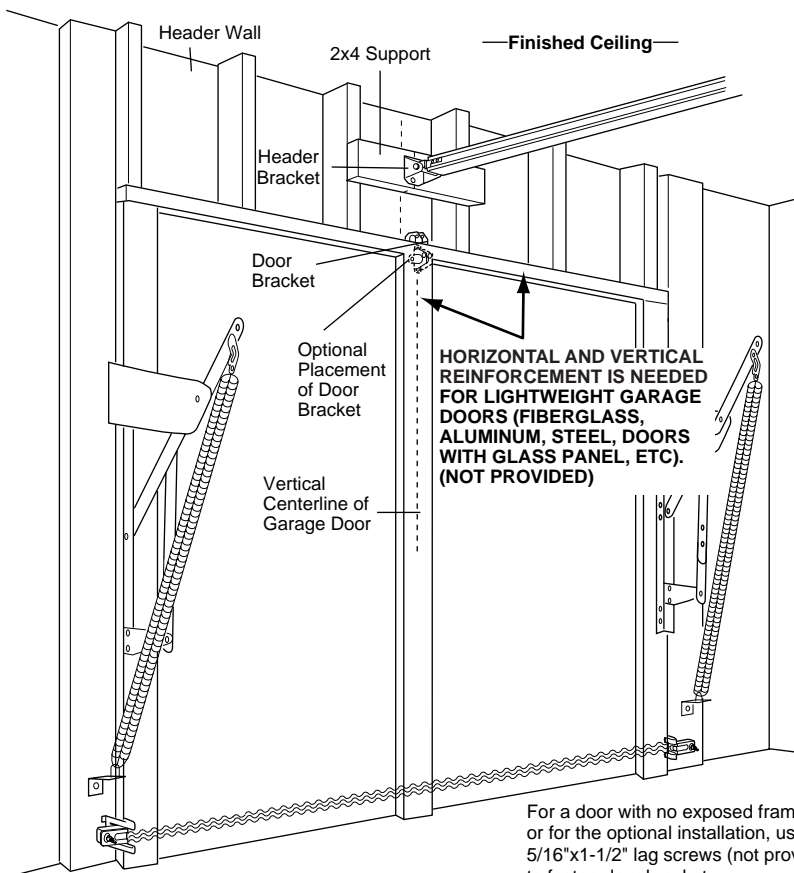
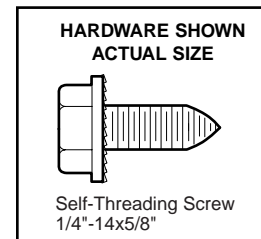

**METAL DOOR**

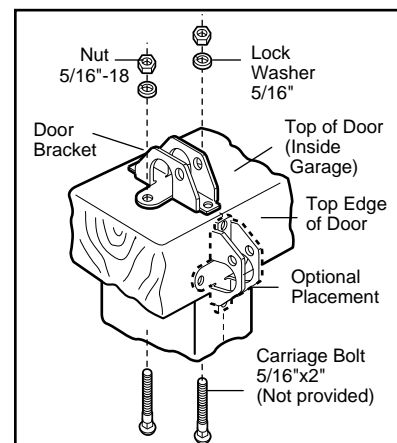

**WOOD DOOR**

# INSTALLATION STEP 12

## Connect Door Arm to Trolley

Follow instructions which apply to your door type as illustrated below and on the following page.

### SECTIONAL DOORS ONLY

Make sure garage door is fully closed. Pull the emergency release handle to disconnect the outer trolley from the inner trolley. Slide the outer trolley back (away from the door) about 2" as shown in Figures 1, 2 and 3.

• **Figure 1:**

- Fasten straight door arm section to outer trolley with the 5/16"x1" clevis pin. Secure the connection with a ring fastener.
- Fasten curved section to the door bracket in the same way, using the 5/16"x1-1/4" clevis pin.

• **Figure 2:**

- Bring arm sections together. Find two pairs of holes that line up and join sections. Select holes as far apart as possible to increase door arm rigidity.

• **Figure 3, Hole alignment alternative:**

- If holes in curved arm are above holes in straight arm, disconnect straight arm. Cut about 6" from the solid end. Reconnect to trolley with cut end as shown.
  - Bring arm sections together.
  - Find two pairs of holes that line up and join with bolts, lock washers and nuts.
- Pull the emergency release handle toward the opener at a 45° angle so that the trolley release arm is horizontal. Proceed to Adjustment Step 1, page 24. Trolley will re-engage automatically when opener is operated.

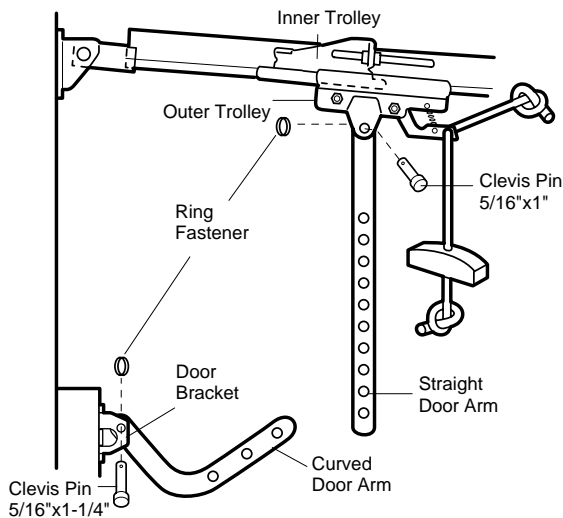

Figure 1

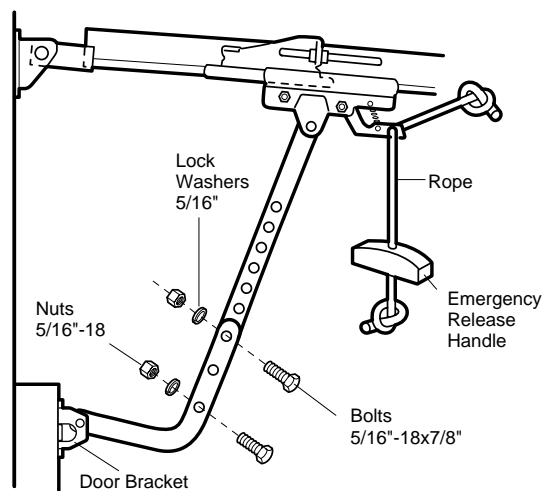

Figure 2

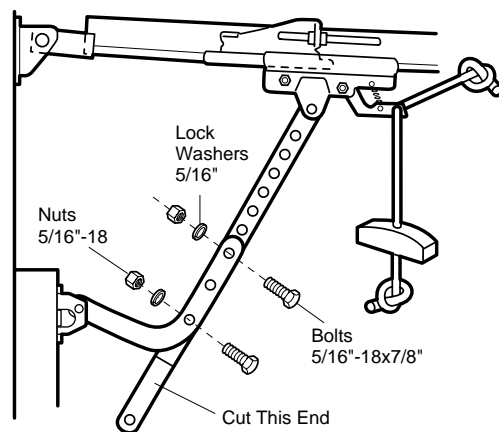
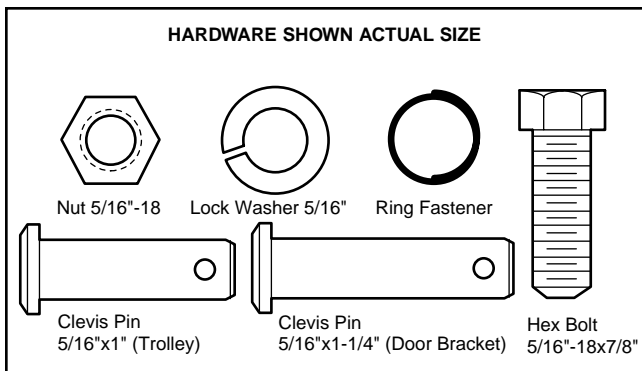

Figure 3



## ALL ONE-PIECE DOORS

### 1. Assemble the Door Arm:

- Fasten the straight and curved door arm sections together to the longest possible length (with a 2 or 3 hole overlap).
- Make sure the garage door is fully closed. Connect the straight door arm section to the door bracket with the 5/16"x1-1/4" clevis pin.
- Secure with a ring fastener.
- Pull the emergency release handle, disconnecting the outer trolley from the inner trolley by pulling straight down on the emergency release handle and sliding the outer trolley back toward the motor unit.
- Connect the curved door arm section to the trolley using the 5/16"x1-1/4" clevis pin and ring fastener.

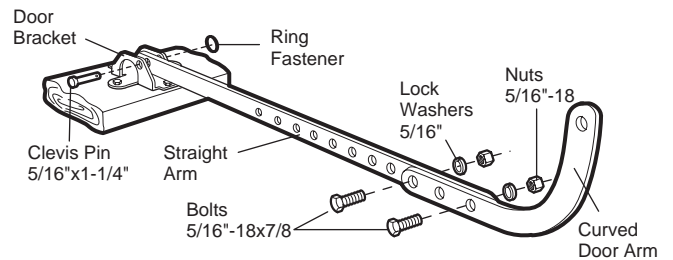

**NOTE:** Adjusting the limits on the following page:

- The trolley will automatically connect. If not, review the trolley lockout feature on page 28.
- When setting the up limit on the following page, the door should not have a "backward" slant when fully open as illustrated below. A slight backward slant will cause unnecessary bucking and/or jerking operation as the door is being opened or closed from the fully open position.

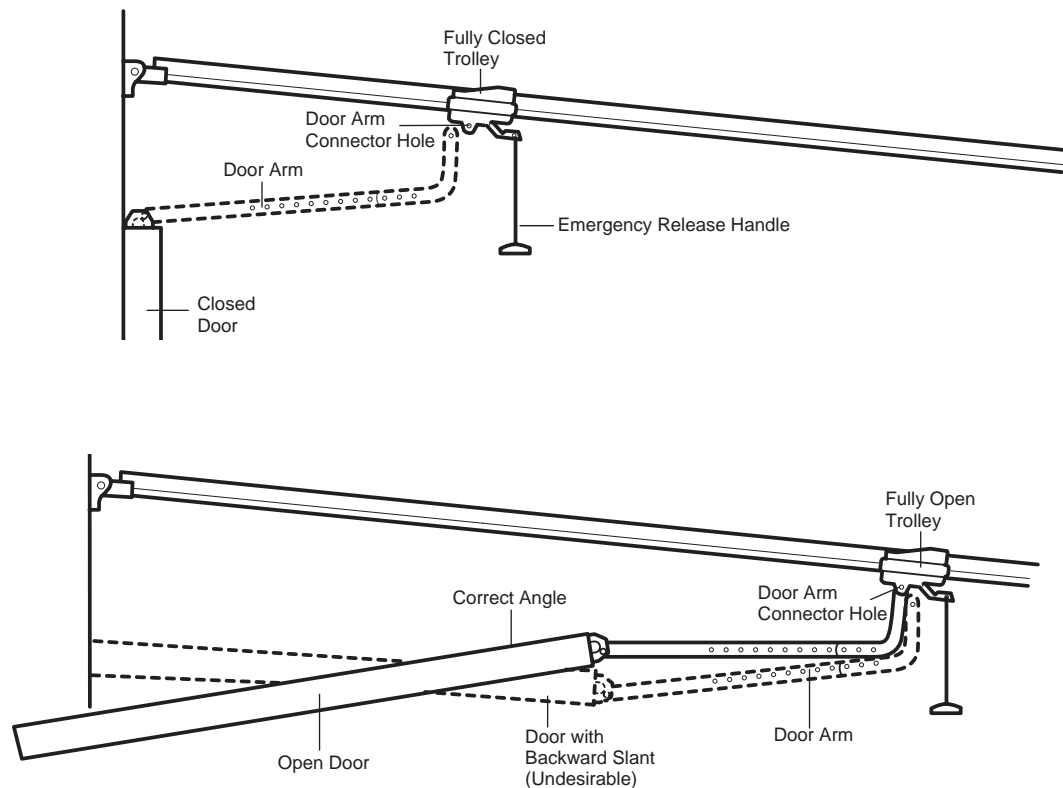

## ADJUSTMENT 1

### Program the travel limits

*Travel limits regulate the points at which the door will stop when moving up or down. Follow the steps below to set the desired up limit. The down limit will be set automatically during step 5. During this step, use the remote control shipped with your opener. Any other remote will not work until its code is programmed into your opener's receiver (see "Programming").*

1. Activate the door using the door control or the remote. The trolley will reconnect and the door will open between 4 and 5 feet.
2. Use the two buttons (1), (2) on the control panel to place the opener into limit setting mode: Press and hold the "Learn" button (2) while you press the "Limit" button on the left (1), then release both buttons. The indicator light (3) will blink slowly. The opener is now in limit learn mode.
3. Press the left button (1) until the door travels up to the desired limit. If the door goes above the desired up limit, press the right button (2) to lower it. Check to be sure the door is high enough for your vehicle. Adjust if necessary, using both buttons.
4. Place a one-inch board (or a 2x4 laid flat) on the floor, centered under the garage door.
5. Press the remote (4) or door control push button. The door will travel down, touch the board, then reverse and stop in the up limit position. The indicator light will stop blinking and turn off. The opener has learned the up and down limits. Remove the wood board.

During step 5, if the door reverses before touching the board, increase the down force (See "Force Adjustment"), then repeat steps 1-5 above.

If the door stops before reaching the up limit, increase the up force by small adjustments until it reaches the up limit. (See "Force Adjustment"). Repeat step 5.

## ! WARNING

Without a properly installed safety reversal system, persons (particularly small children) could be SERIOUSLY INJURED or KILLED by a closing garage door.

- Incorrect adjustment of garage door travel limits will interfere with proper operation of safety reversal system.
- If one control (force or travel limits) is adjusted, the other control may also need adjustment.
- After ANY adjustments are made, the safety reversal system MUST be tested. Door MUST reverse on contact with one-inch high object (or 2x4 laid flat) on floor.

## CAUTION

To prevent damage to vehicles, be sure fully open door provides adequate clearance.

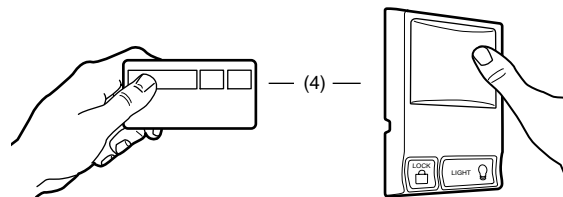
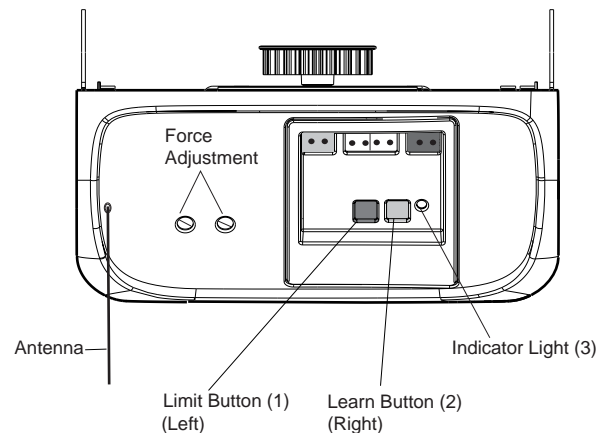



## ADJUSTMENT STEP 2

### Adjust the Force

Force adjustment controls are located on the back panel of the motor unit. Force adjustment settings regulate the amount of power required to open and close the door.

If the forces are set too light, door travel may be interrupted by nuisance reversals in the down direction and stops in the up direction. Weather conditions can affect the door movement, so occasional adjustment may be needed.

**The maximum force adjustment range is about 3/4 of a complete turn. Do not force controls beyond that point.** Turn force adjustment controls with a screwdriver.

**NOTE:** *If anything interferes with the door's upward travel, it will stop. If anything interferes with the door's downward travel (including binding or unbalanced doors), it will reverse.*

### HOW AND WHEN TO ADJUST THE FORCES

#### 1. Test the DOWN (close) force

- Grasp the door bottom when the door is about halfway through DOWN (close) travel. The door should reverse. *Reversal halfway through down travel does not guarantee reversal on a one-inch obstruction. See Adjustment Step 3, page 26.*  
**If the door is hard to hold or doesn't reverse, DECREASE the DOWN (close) force by turning the control counterclockwise.** Make small adjustments until the door reverses normally. After each adjustment, run the opener through a complete cycle.
- **If the door reverses during the down (close) cycle and the opener lights aren't flashing, INCREASE DOWN (close) force by turning the control clockwise.** Make small adjustments until the door completes a close cycle. After each adjustment, run the opener through a complete travel cycle. *Do not increase the force beyond the minimum amount required to close the door.*

#### 2. Test the UP (open) force

- Grasp the door bottom when the door is about halfway through UP (open) travel. The door should stop. **If the door is hard to hold or doesn't stop, DECREASE UP (open) force by turning the control counterclockwise.** Make small adjustments until the door stops easily and opens fully. After each adjustment, run the opener through a complete travel cycle.
- **If the door doesn't open at least 5 feet, INCREASE UP (open) force by turning the control clockwise.** Make small adjustments until door opens completely. Readjust the UP limit if necessary. After each adjustment, run the opener through a complete travel cycle.

## ! WARNING

Without a properly installed safety reversal system, persons (particularly small children) could be **SERIOUSLY INJURED** or **KILLED** by a closing garage door.

- Too much force on garage door will interfere with proper operation of safety reversal system.
- **NEVER** increase force beyond minimum amount required to close garage door.
- **NEVER** use force adjustments to compensate for a binding or sticking garage door.
- If one control (force or travel limits) is adjusted, the other control may also need adjustment.
- After **ANY** adjustments are made, the safety reversal system **MUST** be tested. Door **MUST** reverse on contact with one-inch high object (or 2x4 laid flat) on floor.

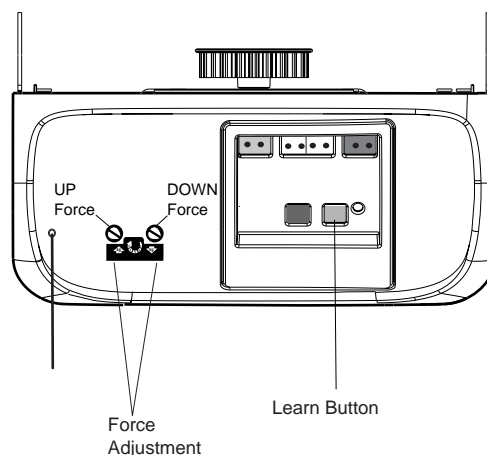

**NOTE:** Both Force Adjustments set at 3 before leaving factory

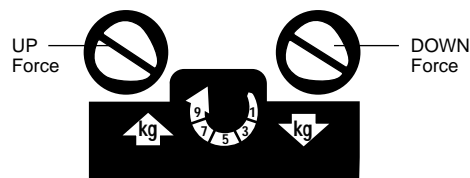

## ADJUSTMENT STEP 3

### Test the Safety Reversal System

#### TEST

- With the door fully open, place a one-inch board (or a 2x4 laid flat) on the floor, centered under the garage door.
- Operate the door in the down direction. The door **must** reverse on striking the obstruction.

#### ADJUST

- If the door stops on the obstruction, it is not traveling far enough in the down direction. See adjustment step 1.  
**NOTE:** On a sectional door, make sure limit adjustments do not force the door arm beyond a straight up and down position. See the illustration on page 22.
- Repeat the test.
- When the door reverses on the one-inch board, remove the obstruction and run the opener through 3 or 4 complete travel cycles to test adjustment.

#### IMPORTANT SAFETY CHECK:

Repeat Adjustment Steps 1, 2 and 3 after:

- Each adjustment of door arm length, limits, or force controls.
- Any repair to or adjustment of the garage door (including springs and hardware).
- Any repair to or buckling of the garage floor.
- Any repair to or adjustment of the opener.

## ADJUSTMENT STEP 4

### Test the Protector System®

- Press the remote control push button to open the door.
- Place the opener carton in the path of the door.
- Press the remote control push button to close the door. The door will not move more than an inch, and the opener lights will flash.

The garage door opener will not close from a remote if the indicator light in either sensor is off (alerting you to the fact that the sensor is misaligned or obstructed).

**If the opener closes the door when the safety reversing sensor is obstructed (and the sensors are no more than 6" above the floor), call for a trained door systems technician.**

## ⚠ WARNING

Without a properly installed safety reversal system, persons (particularly small children) could be **SERIOUSLY INJURED** or **KILLED** by a closing garage door.

- Safety reversal system **MUST** be tested every month.
- If one control (force or travel limits) is adjusted, the other control may also need adjustment.
- After **ANY** adjustments are made, the safety reversal system **MUST** be tested. Door **MUST** reverse on contact with one-inch high object (or 2x4 laid flat) on the floor.

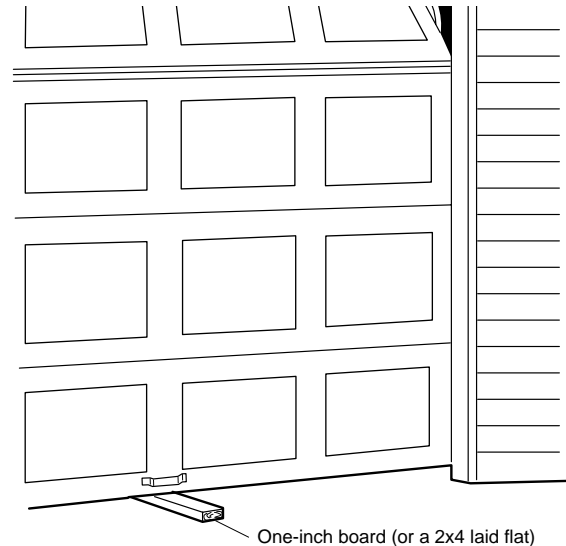

## ⚠ WARNING

Without a properly installed safety reversing sensor, persons (particularly small children) could be **SERIOUSLY INJURED** or **KILLED** by a closing garage door.

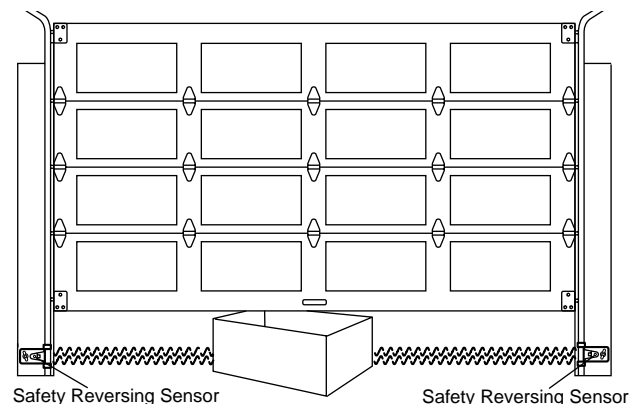

## OPERATION

### IMPORTANT SAFETY INSTRUCTIONS

#### WARNING

#### To reduce the risk of severe injury or death:

1. READ AND FOLLOW ALL WARNINGS AND INSTRUCTIONS.
2. ALWAYS keep remote controls out of reach of children. NEVER permit children to operate or play with garage door control push buttons or remote controls.
3. ONLY activate garage door when it can be seen clearly, it is properly adjusted, and there are no obstructions to door travel.
4. ALWAYS keep garage door in sight until completely closed. NO ONE SHOULD CROSS THE PATH OF THE MOVING DOOR.
5. If possible, use emergency release handle to disengage trolley ONLY when garage door is CLOSED. Weak or broken springs or unbalanced door could result in an open door falling rapidly and/or unexpectedly.
6. NEVER use emergency release handle unless garage doorway is clear of persons and obstructions.
7. NEVER use handle to pull garage door open or closed. If rope knot becomes untied, you could fall.
8. If one control (force or travel limits) is adjusted, the other control may also need adjustment.
9. After ANY adjustments are made, the safety reversal system MUST be tested.
10. Safety reversal system MUST be tested every month. Garage door MUST reverse on contact with one-inch high object (or a 2x4 laid flat) on the floor.
11. ALWAYS KEEP GARAGE DOOR PROPERLY BALANCED (see page 3). An improperly balanced door may not reverse when required and could result in severe injury or death.
12. All repairs to cables, spring assemblies and other hardware, all of which are under EXTREME tension, MUST be made by a trained door systems technician.
13. ALWAYS disconnect electric power to garage door opener before making any repairs or removing covers.
14. **SAVE THESE INSTRUCTIONS.**

### Using Your Garage Door Opener

Your Security+ opener and hand-held remote control have been factory programmed to a matching code which changes with each use, randomly accessing over 100 billion new codes. Your opener will operate with several Security+ remote controls utilizing up to 8 functions, and one Security+ Keyless Entry System. If you purchase a new remote, or if you wish to deactivate any remote, follow the instructions in the *Programming* section.

#### Activate your opener with any of the following:

- *The hand-held Remote Control:* Hold the large push button down until the door starts to move.
- *The wall-mounted Door Control:* Hold the push bar down until the door starts to move.
- *The Keyless Entry (See Accessories)* If provided with your garage door opener, it must be programmed before use. See *Programming*.

#### When the opener is activated (with the safety reversing sensor correctly installed and aligned)

1. If open, the door will close. If closed, it will open.
2. If closing, the door will reverse.
3. If opening, the door will stop.
4. If the door has been stopped in a partially open position, it will close.
5. If obstructed while closing, the door will reverse. If the obstruction interrupts the sensor beam, the opener lights will blink for five seconds.

6. If obstructed while opening, the door will stop.
7. If fully open, the door will not close when the beam is broken. The sensor has no effect in the opening cycle.

If the sensor is not installed, or is misaligned, the door won't close from a hand-held remote. However, you can close the door with the Door Control, the Outside Keylock, or Keyless Entry, *if you activate them until down travel is complete*. If you release them too soon, the door will reverse.

**The opener lights** will turn on under the following conditions: when the opener is initially plugged in; when power is restored after interruption; when the opener is activated.

They will turn off automatically after 4-1/2 minutes or provide constant light when the Light feature on the Multi-Function Door Control is activated. Bulb size is 100 watts maximum.

**Security+ light feature:** Lights will also turn on when someone walks through the open garage door. With a Multi-Function Door Control, this feature may be turned off as follows: With the opener lights off, press and hold the light button for 10 seconds, until the light goes on and off again. To restore this feature, start with the opener lights on, then press and hold the light button for 10 seconds until the light goes off, then on again.

## Using the Wall-Mounted Door Control

### THE MULTI-FUNCTION DOOR CONTROL

Press the push bar to open or close the door. Press again to reverse the door during the closing cycle or to stop the door while it's opening.

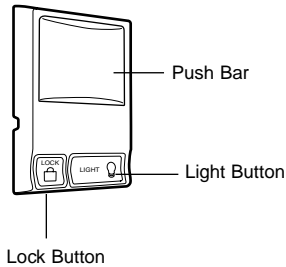

#### Light feature

Press the Light button to turn the opener light on or off. It will not control the opener lights when the door is in motion. If you turn it on and then activate the opener, the light will remain on for 4-1/2 minutes. Press again to turn it off sooner.

#### Lock feature

Designed to prevent operation of the door from hand-held remote controls. However, the door will open and close from the Door Control, the Outside Keylock and the Keyless Entry Accessories.

To activate, press and hold the Lock button for 2 seconds. The push bar light will flash as long as the Lock feature is on.

To turn off, press and hold the Lock button again for 2 seconds. The push bar light will stop flashing. The Lock feature will also turn off whenever the "Smart" (learn) button on the motor unit panel is activated.

#### Additional features when used with the 3-Channel hand-held remote

##### A) To control the opener lights:

In addition to operating the door, you may program the remote to operate the lights.

1. With the door closed, press and hold a small remote button that you want to control the light.
2. Press and hold the Light button on the Multi-Function door control.
3. While holding the Light button, press and hold the Lock button on the door control.
4. After the opener lights flash, release all buttons.

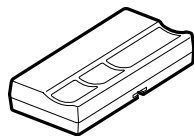

B) To operate one door using all three buttons on the hand-held remote:

You may program the remote to open the door with the large button, close it with the middle button, and stop the door's movement with the third button.

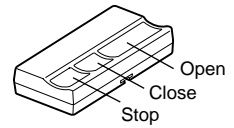

**NOTE:** If remote is already programmed, you must first erase all codes. See Programming.

1. With the door closed, press and hold the large remote push button.
2. Press and hold the Lock button on the door control for a minimum of one second before proceeding to next step.
3. Press and hold the door control push bar.
4. After the opener lights flash, release all buttons.

### To Open the Door Manually

#### ⚠ WARNING

- To prevent possible **SERIOUS INJURY** or **DEATH** from a falling garage door:
  - If possible, use emergency release handle to disengage trolley **ONLY** when garage door is **CLOSED**. Weak or broken springs or unbalanced door could result in an open door falling rapidly and/or unexpectedly.
  - **NEVER** use emergency release handle unless garage doorway is clear of persons and obstructions.
- **NEVER** use handle to pull door open or closed. If rope knot becomes untied, you could fall.

The door should be fully closed if possible. Pull down on the emergency release handle and lift the door manually. To reconnect the door to the opener, press the door control push bar.

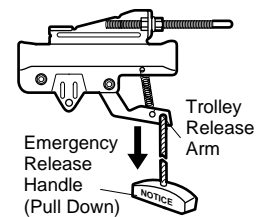

**MANUAL DISCONNECT POSITION**

The *lockout feature* prevents the trolley from reconnecting automatically. Pull the emergency release handle down and back (toward the opener). The door can then be raised and lowered manually as often as necessary. To disengage the lockout feature, pull the handle straight down. The trolley will reconnect on the next UP or DOWN operation.

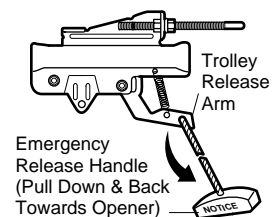

**LOCKOUT POSITION**

## CARE OF YOUR OPENER

### LIMIT AND FORCE ADJUSTMENTS:

Weather conditions may cause some minor changes in door operation requiring some re-adjustments, particularly during the first year of operation.

Pages 24 and 25 refer to the limit and force adjustments. Only a screwdriver is required. Follow the instructions carefully.

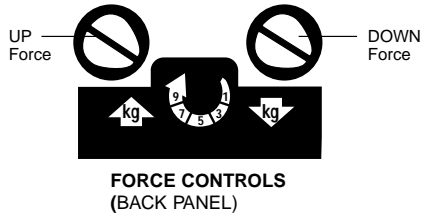

Repeat the safety reverse test (Adjustment Step 3, page 26) after any adjustment of limits or force.

### THE REMOTE CONTROL BATTERY

The lithium battery should produce power for up to 5 years. To replace battery, use the visor clip or screwdriver blade to pry open the case as shown. Insert battery positive side up.

Dispose of old battery properly.

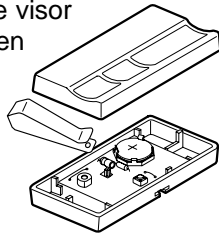

## HAVING A PROBLEM?

### 1. The opener doesn't operate from either the Door Control or the remote control:

- Does the opener have electric power? Plug a lamp into the outlet. If it doesn't light, check the fuse box or the circuit breaker. (Some outlets are controlled by a wall switch.)
- Have you disabled all door locks? Review installation instruction warnings on page 7.
- Is there a build-up of ice or snow under the door? The door may be frozen to the ground. Remove any restriction.
- The garage door spring may be broken. Have it replaced.

### 2. Opener operates from the remote, but not from the Door Control:

- Is the door control lit? If not, reverse the wires. If the opener runs, check for a faulty wire connection at the door control, a short under the staples, or a broken wire.
- Are the wiring connections correct? Review *Installation Step 6*, page 14.

## MAINTENANCE SCHEDULE

### Once a Month

- Manually operate door. If it is unbalanced or binding, call a trained door systems technician.
- Check to be sure door opens & closes fully. Adjust limits and/or force if necessary. (See pages 24 and 25.)
- Repeat the safety reverse test. Make any necessary adjustments. (See Adjustment Step 3.)

### Once a Year

- Oil door rollers, bearings and hinges. The opener does not require additional lubrication. Do not grease the door tracks.

## WARNING

To prevent possible SERIOUS INJURY or DEATH:

- NEVER allow small children near batteries.
- If battery is swallowed, immediately notify doctor.

NOTICE: To comply with FCC and or Industry Canada (IC) rules, adjustment or modifications of this receiver and/or transmitter are prohibited, except for changing the code setting or replacing the battery. THERE ARE NO OTHER USER SERVICEABLE PARTS. Tested to Comply with FCC Standards FOR HOME OR OFFICE USE. Operation is subject to the following two conditions: (1) this device may not cause harmful interference, and (2) this device must accept any interference received, including interference that may cause undesired operation.

### 3. The door operates from the Door Control, but not from the remote control:

- Is the door push bar flashing? If your model has the Lock feature, make sure it is off.
- Program the opener to match the remote control code. (Refer to instructions on the motor unit panel.) Repeat with all remotes.

### 4. The remote control has short range:

- Change the location of the remote control in your car.
- Check to be sure the antenna on the side or back panel of motor unit extends fully downward.
- Some installations may have shorter range due to a metal door, foil backed insulation, or metal garage siding.

### 5. Opener noise is disturbing in living quarters of home:

- If operational noise is a problem because of proximity of the opener to the living quarters, the Vibration Isolator Kit 41A3263 can be installed. This kit was designed to minimize vibration to the house and is easy to install.

## **Having a Problem? (Continued)**

### **6. The garage door opens and closes by itself:**

- Be sure that all remote control push buttons are off.
- Remove the bell wire from the door control terminals and operate from the remote only. If this solves the problem, the door control is faulty (replace), or there is an intermittent short on the wire between the door control and the motor unit.
- Clear memory and re-program all remote controls.

### **7. The door doesn't open completely:**

- Is something obstructing the door? Is it out of balance, or are the springs broken? Remove the obstruction or repair the door.
- If the door is in good working order but now doesn't open all the way, increase the up force. See *Adjustment Step 2*.
- If the door opens at least 5 feet, the travel limits may need to be adjusted. See *Adjustment Step 1*.

### **8. The door stops but doesn't close completely:**

- Review the travel limits adjustment procedures on *Adjustment Step 1*.

*Repeat the safety reverse test after any adjustment of door arm length, close force or down limit.*

### **9. The door opens but won't close:**

- If the opener lights blink, check the safety reversing sensor. See *Installation Step 10*.
- If the opener lights don't blink and it is a new installation, check the down force. See *Adjustment Step 2*. For an existing installation, see below.

*Repeat the safety reverse test after the adjustment is complete.*

### **10. The door reverses for no apparent reason and opener lights don't blink:**

- Is something obstructing the door? Pull the emergency release handle. Operate the door manually. If it is unbalanced or binding, call a trained door systems technician.
- Clear any ice or snow from the garage floor area where the door closes.
- Review *Adjustment Step 2*.

*Repeat safety reverse test after adjustments to force or travel limits. The need for occasional adjustment of the force and limit settings is normal. Weather conditions in particular can affect door travel.*

### **11. The door reverses for no apparent reason and opener lights blink for 5 seconds after reversing:**

- Check the safety reversing sensor. Remove any obstruction or align the receiving eye. See *Installation Step 10*.

### **12. The opener lights don't turn on:**

- Replace the light bulbs (100 watts maximum). Use a standard neck garage door opener bulb if regular bulb burns out.

### **13. The opener lights don't turn off:**

- Is the Light feature on? Turn it off.

### **14. The opener strains or maximum force is needed to operate door:**

- The door may be out of balance or the springs may be broken. **Close the door** and use the emergency release handle to disconnect the trolley. Open and close the door manually. A properly balanced door will stay in any point of travel while being supported entirely by its springs. If it does not, disconnect the opener and call a trained door systems technician. **Do not increase the force to operate the opener.**

### **15. The opener motor hums briefly, then won't work:**

- The garage door springs may be broken. See above.
- If the problem occurs on the first operation of the opener, door may be locked. Disable the door lock.

### **16. The opener won't operate due to power failure:**

- Use the emergency release handle to disconnect the trolley. The door can be opened and closed manually. When power is restored, press the Door Control push bar and trolley will automatically reconnect (unless trolley is in lockout position.) See page 28.
- The Outside Quick Release accessory (for use on garages with no service door) disconnects the trolley from outside the garage in case of power failure.

# PROGRAMMING

Your garage door opener has already been programmed at the factory to operate with your hand-held remote control. The door will open and close when you press the large push button.

Below are instructions for programming your opener to operate with additional Security+ remote controls.

## To Add an Additional Hand-held Remote Control

### USING THE "LEARN" BUTTON

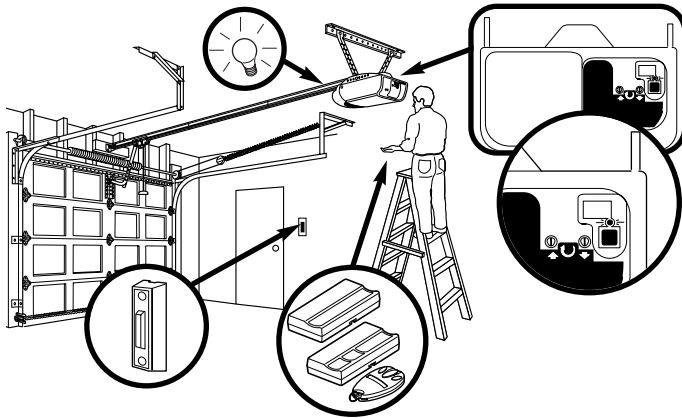

1. Press and release the "learn" button on the motor unit. The learn indicator light will glow steadily for 30 seconds.

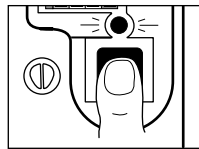

2. Within 30 seconds, press and hold the button on the hand-held remote\* that you wish to operate your garage door.

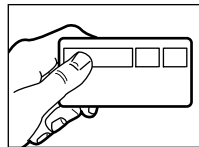

3. Release the button when the motor unit lights blink. It has learned the code. If light bulbs are not installed, two clicks will be heard.

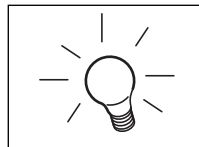

### USING THE MULTI-FUNCTION DOOR CONTROL

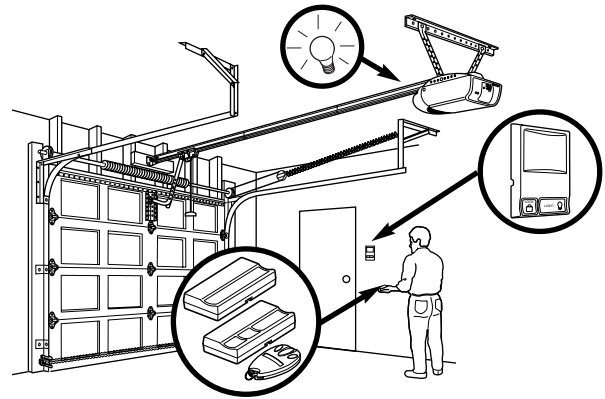

1. Press and hold the button on the hand-held remote\* that you wish to operate your garage door.

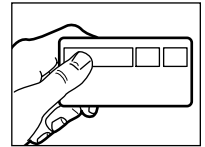

2. While holding the remote button, press and hold the LIGHT button on the Multi-Function Door Control.

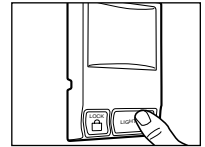

3. Continue holding both buttons while you press the push bar on the Multi-Function Door Control (all three buttons are held).

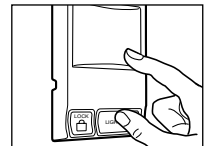

4. Release buttons when the motor unit lights blink. It has learned the code. If light bulbs are not installed, two clicks will be heard.



### To Erase All Codes From Motor Unit Memory

To deactivate any unwanted remote, first erase all codes:

Press and hold the "learn" button on motor unit until the learn indicator light goes out (approximately 6 seconds). All previous codes are now erased. Reprogram each remote or keyless entry you wish to use.

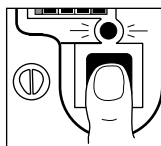

### \*3-Channel Remotes

If provided with your garage door opener, the large button is factory programmed to operate it. Additional buttons on any Security+ 3-channel remote or mini-remote can be programmed to operate other Security+ garage door openers.

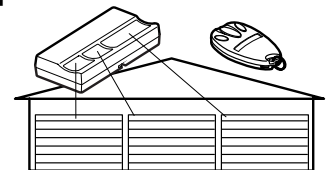

## To Add or Change a Keyless Entry PIN

**NOTE:** Your new Keyless Entry must be programmed to operate your garage door opener.

### USING THE "LEARN" BUTTON

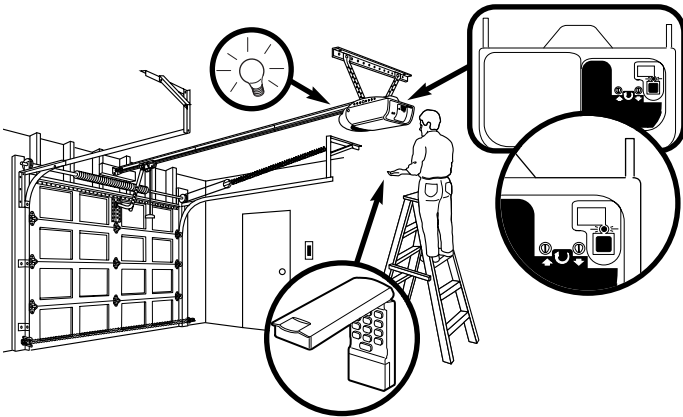

1. Press and release the "learn" button on motor unit. The learn indicator light will glow steadily for 30 seconds.
2. Within 30 seconds, enter a four digit personal identification number (PIN) of your choice on the keypad. Then press and hold the ENTER button.
3. Release the button when the motor unit lights blink. It has learned the code. If light bulbs are not installed, two clicks will be heard.

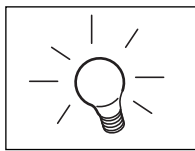
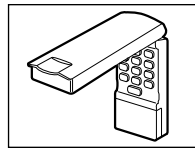
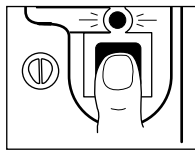

### To change an existing, known PIN

If the existing PIN is known, it may be changed by one person without using a ladder.

1. Press the four buttons for the present PIN, then press and hold the # button.

The opener light will blink twice. Release the # button.

2. Press the new 4-digit PIN you have chosen, then press Enter.

The motor unit lights will blink once when the PIN has been learned.

Test by pressing the new PIN, then press Enter. The door should move.

### To set a temporary PIN

You may authorize access by visitors or service people with a temporary 4-digit PIN. After a programmed number of hours or number of accesses, this temporary PIN expires and will no longer open the door. It can be used to *close* the door even after it has expired. To set a temporary PIN:

1. Press the four buttons for your personal entry PIN (not the last temporary PIN), then press and hold the \* button.

The opener light will blink three times. Release the button.

### USING THE MULTI-FUNCTION DOOR CONTROL

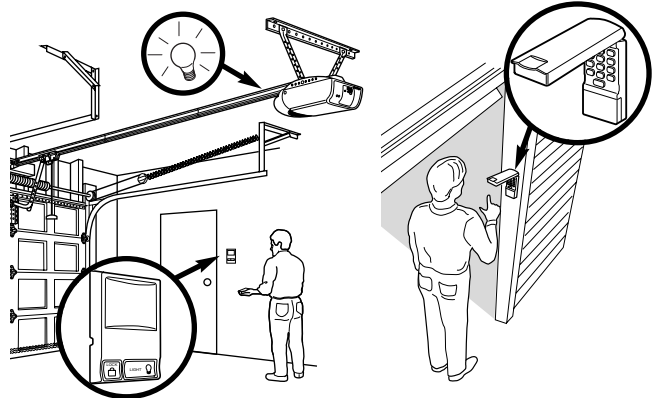

**NOTE:** This method requires two people if the Keyless Entry is already mounted outside the garage.

1. Enter a four digit personal identification number (PIN) of your choice on the keypad. Then press and hold ENTER.

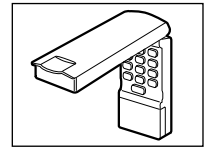

2. While holding the ENTER button, press and hold the LIGHT button on the Multi-Function Door Control.

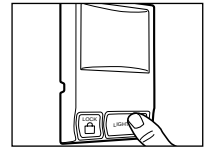

3. Continue holding the ENTER and LIGHT buttons while you press the push bar on the Multi-Function Door Control (all three buttons are held).

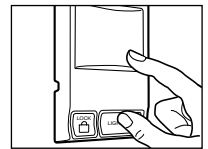

4. Release buttons when the motor unit lights blink. It has learned the code. If light bulbs are not installed, two clicks will be heard.



2. Press the temporary 4-digit PIN you have chosen, then press Enter.

The opener light will blink four times.

3. To set the number of **hours** this temporary PIN will work, press the number of hours (up to 255), then press \*.

**OR**

3. To set the number of **times** this temporary PIN will work, press the number of times (up to 255), then press #.

The opener light will blink once when the temporary PIN has been learned.

Test by pressing the four buttons for the temporary PIN, then press Enter. The door should move. If the temporary PIN was set to a certain number of openings, remember that the test has used up one opening. To clear the temporary password, repeat steps 1-3, setting the number of hours or times to 0 in step 3.



# REPAIR PARTS

## Rail Assembly Parts

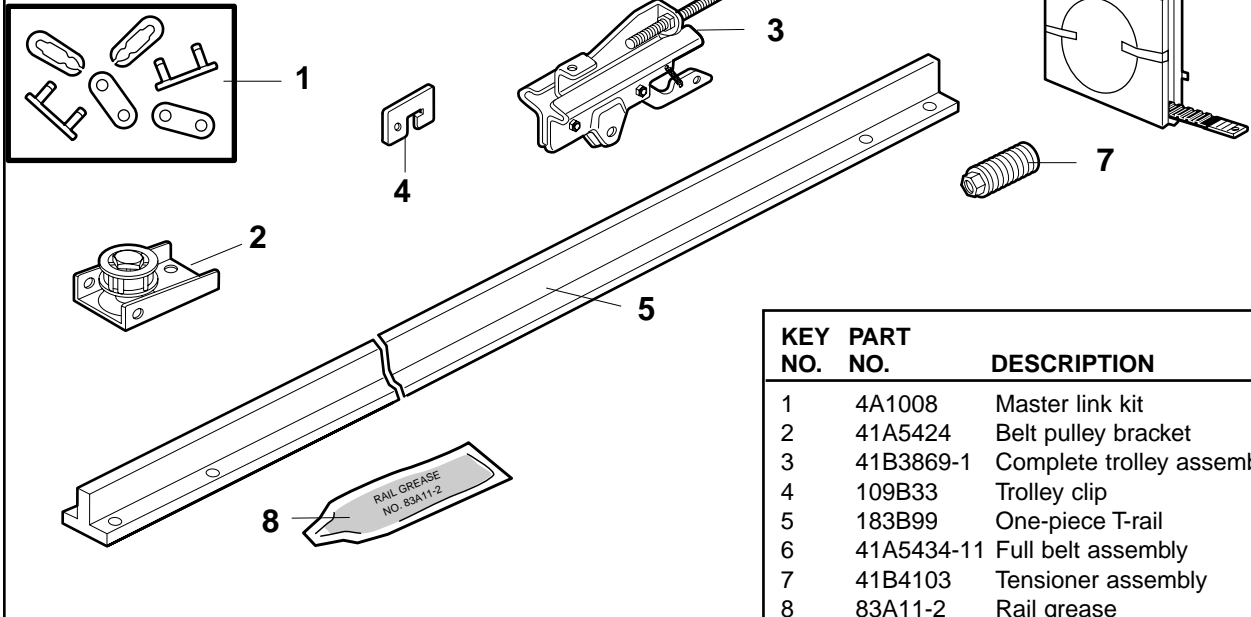

KEY NO.	PART NO.	DESCRIPTION
1	4A1008	Master link kit
2	41A5424	Belt pulley bracket
3	41B3869-1	Complete trolley assembly
4	109B33	Trolley clip
5	183B99	One-piece T-rail
6	41A5434-11	Full belt assembly
7	41B4103	Tensioner assembly
8	83A11-2	Rail grease

## Installation Parts

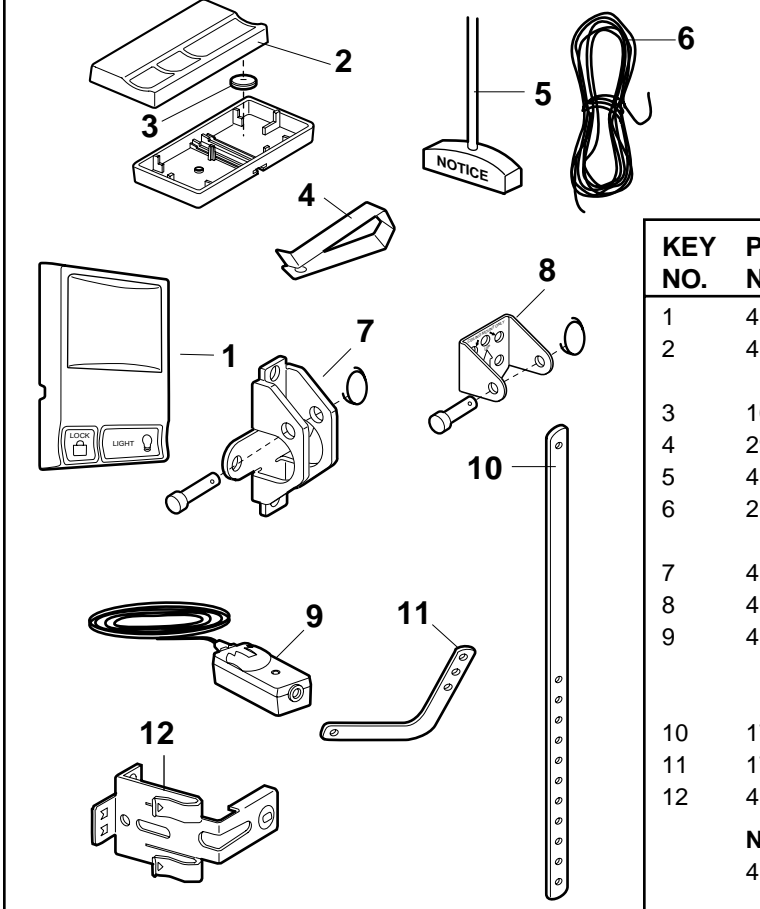

KEY NO.	PART NO.	DESCRIPTION
1	41C494	Multi-function door control panel
2	41A5056-3	3-Channel remote control housing (no circuit board)
3	10A20	3V2032 Lithium battery
4	29B137	Remote control visor clip
5	41A2828	Emergency release rope & handle assy
6	217A238	2-Conductor bell wire - white & white/red
7	41A5047-1	Door bracket w/clevis pin & fastener
8	41A4353-1	Header bracket w/clevis pin & fastener
9	41A5034	Safety sensor kit (receiving and sending eyes) with 3' 2-conductor bell wire attached
10	178B34	Straight door arm section
11	178B35	Curved door arm section
12	41A5266-1	Safety sensor brackets (2)
<b>NOT SHOWN</b>		
	41A2770-5	Installation hardware bag (includes hardware listed on page 5)
	114A2503	Owner's manual

## Motor Unit Assembly Parts

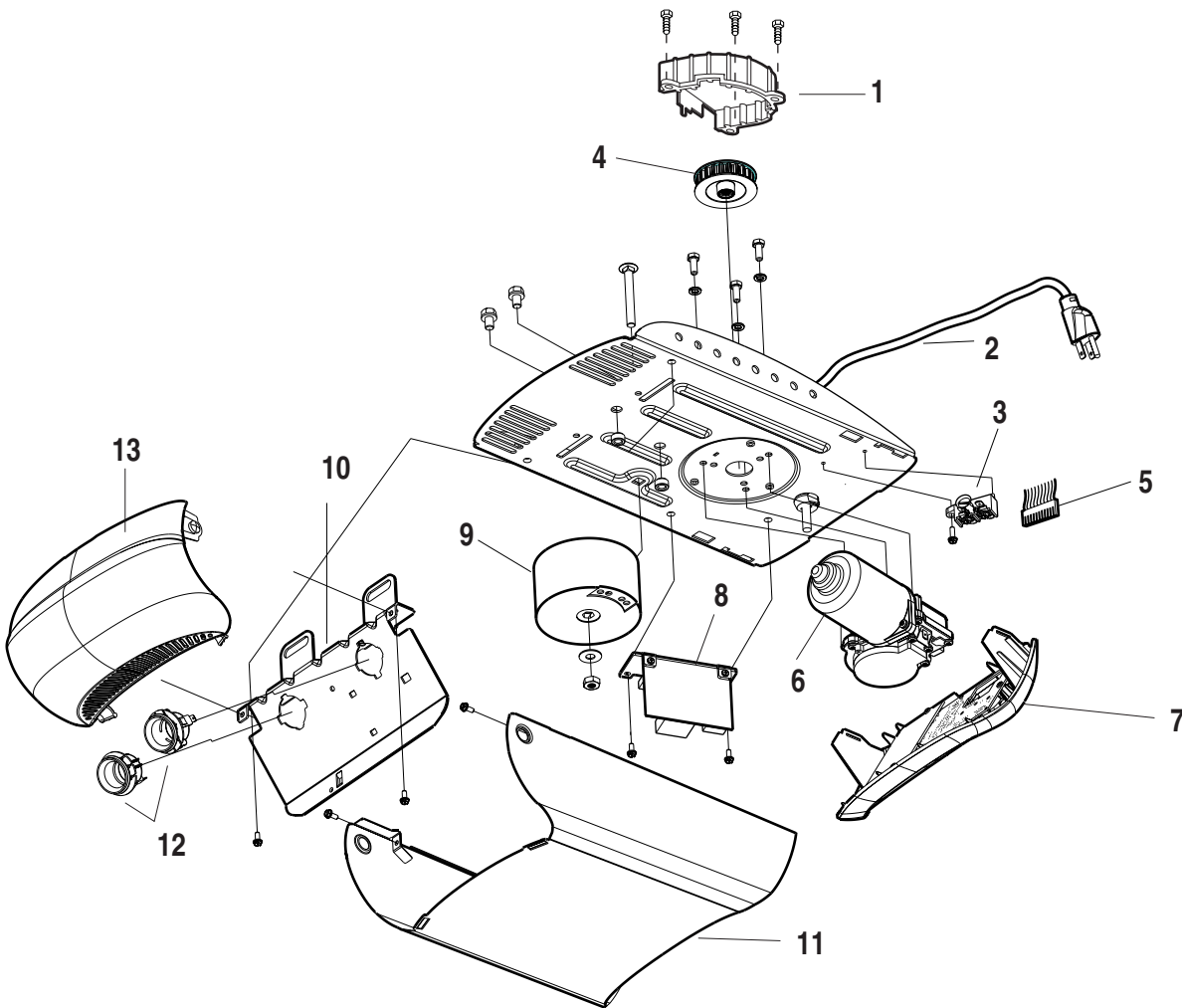

KEY NO.	PART NO.	DESCRIPTION	KEY NO.	PART NO.	DESCRIPTION
1	41A4371-1	Belt cap	7	41A5507	Receiver logic board assy with end panel
2	41B4245-1	Line cord		41D183	End panel only
3	41B3150-1	Terminal block w/screws	8	41B5351-4	Power supply
4	41C53	Belt cog	9	41C153	Transformer
5	41C5317	Wire harness	10	41D630-2	Bracket: light socket, limit switch
	41C5511	High voltage wire harness	11	41A549	Cover
	41B5405	DC motor wire harness	12	175C147	Light socket
	41C5418	Light socket wire harness	13	108D60	Light lens
6	41D475	Motor 80kg/100kg			

# ACCESSORIES

1702LM

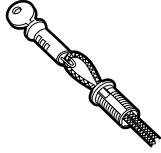

**Outside Quick Release:**

Required for a garage with NO access door. Enables homeowner to open garage door manually from outside by disengaging trolley.

982LM



**Plug-In Light Control:**

Enables homeowner to turn on a lamp, television or other appliance from car, bedside, or anywhere in the home with a remote.

2778LM

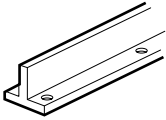

**8 Foot Complete Rail:**

To allow an 8 foot door to open fully.

973LM

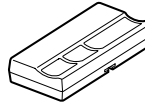

**SECURITY+ 3-Channel Remote Control:**

Includes visor clip.

2770LM

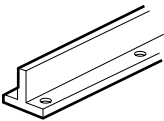

**10 Foot Complete Rail:**

To allow a 10 foot door to open fully.

974LM

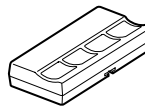

**SECURITY+ 4-Channel Remote Control:**

Includes visor clip.

97LM

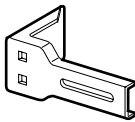

**Extension Brackets:**

(Optional) For safety sensor installation onto the wall or floor.

970LM



**SECURITY+ 3-Channel Mini Remote Control:**

With key ring and velcro fastening strip.

976LM

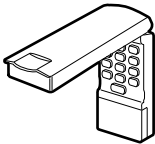

**SECURITY+ Keyless Entry:**

Enables homeowner to operate garage door opener from outside by entering a password on a specially designed keyboard. Also can add a temporary password for visitors or service persons. This temporary password can be limited to a programmable number of hours or entries.

98LM



**Motion Detecting Control Panel:**

Multi-function door control with motion sensor that automatically turns opener lights on for 5 minutes when it detects a person entering the garage. Sensor can be easily deactivated when desired.

# LIFTMASTER SERVICE IS ON CALL

OUR LARGE SERVICE ORGANIZATION  
SPANS AMERICA

INSTALLATION AND SERVICE INFORMATION IS AS  
NEAR AS YOUR TELEPHONE SEVEN DAYS A  
WEEK. SIMPLY DIAL OUR TOLL FREE NUMBER:

**1-800-528-2817**

HOURS: (Central Std. Time)  
6:00 A.M. TO 7:00 P.M. Monday through Friday  
8:00 A.M. TO 6:00 P.M. Saturday  
8:00 A.M. TO 4:30 P.M. Sunday

[www.liftmaster.com](http://www.liftmaster.com)

For professional installation, parts and service,  
contact your local LIFTMASTER/ CHAMBERLAIN  
dealer. Look for him in the Yellow Pages, or call our  
service number for a list of dealers in your area.

# HOW TO ORDER REPAIR PARTS

Selling prices will be furnished on request or parts will  
be shipped at prevailing prices and you will be billed  
accordingly.

WHEN ORDERING REPAIR PARTS, ALWAYS GIVE  
THE FOLLOWING INFORMATION:

- PART NUMBER
- PART NAME
- MODEL NUMBER

ADDRESS ORDERS TO:

THE CHAMBERLAIN GROUP, INC.  
Technical Support Group  
6020 S. Country Club Road  
Tucson, Arizona 85706

SERVICE INFORMATION TOLL FREE NUMBER:  
**1-800-528-2817**

## LIFTMASTER GARAGE DOOR OPENER FIVE-YEAR LIMITED WARRANTY

The Chamberlain Group, Inc. ("Seller") warrants to the first retail purchaser of this product, for the residence in which this product is originally installed, that it will be free from any defect in materials and/or workmanship for a period of 60 full months from the date of purchase. Additionally, the motor and drive belt are warranted for the lifetime of the product. The product must be used in complete accordance with Chamberlain's instructions for installation, operation and care. **The proper operation of this product is dependent on your compliance with the Owner's Manual instructions regarding installation, operation, maintenance and testing. Failure to comply strictly with those instructions will void this warranty in its entirety. Please note that the safety reverse system, in order to operate properly with your garage door, must be adjusted and periodically tested in accordance with the Owner's Manual.**

If, during the limited warranty period, it appears as though this product contains a defect which is covered by this limited warranty, **CALL OUR TOLL FREE SERVICE NUMBER, BEFORE DISMANTLING THIS PRODUCT, AT (1-800-528-2817).** Then send this product, pre-paid and insured, to our service center for warranty repair. You will be advised of shipping instructions when you call the toll free service number. Please include a brief description of the problem and a dated proof-of-purchase receipt with any product that is returned for warranty repair.

Products returned to Seller for warranty repair, which upon receipt by Seller are confirmed to be defective and covered by this limited warranty, will be repaired or replaced (at Seller's sole option) at no cost to you and returned pre-paid. Defective parts will be repaired or replaced with new or factory-rebuilt parts at Seller's sole option.

**THIS LIMITED WARRANTY IS IN LIEU OF ANY OTHER WARRANTIES, EXPRESS OR IMPLIED, INCLUDING ANY IMPLIED WARRANTY OF MERCHANTABILITY OR FITNESS FOR A PARTICULAR PURPOSE, OR OTHERWISE, AND OF ANY OTHER OBLIGATIONS OR LIABILITY ON SELLER'S PART. THIS LIMITED WARRANTY DOES NOT COVER NON-DEFECT DAMAGE, DAMAGE CAUSED BY IMPROPER INSTALLATION, OPERATION OR CARE (INCLUDING, BUT NOT LIMITED TO ABUSE, MISUSE, FAILURE TO PROVIDE REASONABLE AND NECESSARY MAINTENANCE, USE OF UNAUTHORIZED PARTS OR ACCESSORIES, UNAUTHORIZED REPAIRS, OR ANY ALTERATIONS TO THIS PRODUCT), LABOR CHARGES FOR DISMANTLING OR REINSTALLING A REPAIRED OR REPLACED UNIT, REPLACEMENT OF BATTERIES AND LIGHT BULBS, OR UNITS INSTALLED FOR NON-RESIDENTIAL USE. THE USE OF UNAUTHORIZED PARTS OR ACCESSORIES WILL VOID THIS LIMITED WARRANTY.** If you have any questions as to whether accessories or replacement parts are authorized, please contact Chamberlain.

**THIS LIMITED WARRANTY DOES NOT COVER ANY PROBLEMS WITH, OR RELATING TO, THE GARAGE DOOR OR GARAGE DOOR HARDWARE, INCLUDING BUT NOT LIMITED TO THE DOOR SPRINGS, DOOR ROLLERS, DOOR ALIGNMENT AND HINGES. ANY SERVICE CALL THAT DETERMINES THE PROBLEM HAS BEEN CAUSED BY ANY OF THESE ITEMS COULD RESULT IN A FEE TO YOU.**

**UNDER NO CIRCUMSTANCES SHALL SELLER BE LIABLE FOR CONSEQUENTIAL, INCIDENTAL OR SPECIAL DAMAGES ARISING IN CONNECTION WITH THE USE OF, OR INABILITY TO USE, THIS PRODUCT. IN NO EVENT SHALL SELLER'S LIABILITY FOR BREACH OF WARRANTY, BREACH OF CONTRACT, NEGLIGENCE OR STRICT LIABILITY EXCEED THE COST OF THE PRODUCT COVERED HEREBY. NO PERSON IS AUTHORIZED TO ASSUME FOR US ANY OTHER LIABILITY IN CONNECTION WITH THE SALE OF THIS PRODUCT.**

Some states do not allow the exclusion or limitation of consequential, incidental or special damages, so the above limitation or exclusion may not apply to you. This limited warranty gives you specific legal rights, and you may also have other rights which vary from state to state.

## LIFETIME MOTOR & BELT WARRANTY

The motor and belt are fully warranted for the lifetime of the product to the first-time purchaser.