

Click SAVE to save this manual to your computer. Thank you for choosing Honda.

HONDA[®]

ENGINES

OWNER'S MANUAL

G100

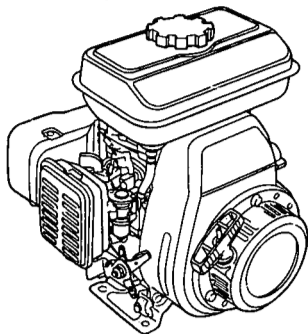

WARNING:



The engine exhaust from this product contains chemicals known to the State of California to cause cancer, birth defects or other reproductive harm.

INTRODUCTION

Thank you for purchasing a Honda engine. We want to help you to get the best results from your new engine and to operate it safely. This manual contains information on how to do that; please read it carefully before operating the engine. If a problem should arise, or if you have any questions about your engine, consult an authorized Honda servicing dealer.

All information in this publication is based on the latest product information available at the time of printing. Illustrations are based on the G100QA model. Honda Motor Co., Ltd. reserves the right to make changes at any time without notice and without incurring any obligation. No part of this publication may be reproduced without written permission.

This manual should be considered a permanent part of the engine and should remain with the engine if resold.

SAFETY MESSAGES

Your safety and the safety of others is very important. We have provided important safety messages in this manual and on the engine. Please read these messages carefully.

A safety message alerts you to potential hazards that could hurt you or others. Each safety message is preceded by a safety alert symbol  and one of three signal words: DANGER, WARNING, or CAUTION.

These signal words mean:

 **DANGER**

You **WILL** be **KILLED** or **SERIOUSLY HURT** if you don't follow instructions.

 **WARNING**

You **CAN** be **KILLED** or **SERIOUSLY HURT** if you don't follow instructions.

 **CAUTION**

You **CAN** be **HURT** if you don't follow instructions.

Each message tells you what the hazard is, what can happen, and what you can do to avoid or reduce injury.

DAMAGE PREVENTION MESSAGES

You will also see other important messages that are preceded by the word NOTICE.

This word means:

NOTICE

Your engine or other property can be damaged if you don't follow instructions.

The purpose of these messages is to help prevent damage to your engine, other property, or the environment.

SAFETY INFORMATION

- Understand the operation of all controls and learn how to stop the engine quickly in case of emergency. Make sure the operator receives adequate instruction before operating the equipment.
- Your engine's exhaust contains poisonous carbon monoxide. Do not run the engine without adequate ventilation, and never run the engine indoors.
- The engine and exhaust become very hot during operation. Keep the engine at least 1 meter (3 feet) away from buildings and other equipment during operation. Keep flammable materials away, and do not place anything on the engine while it is running.

COMPONENT & CONTROL LOCATION

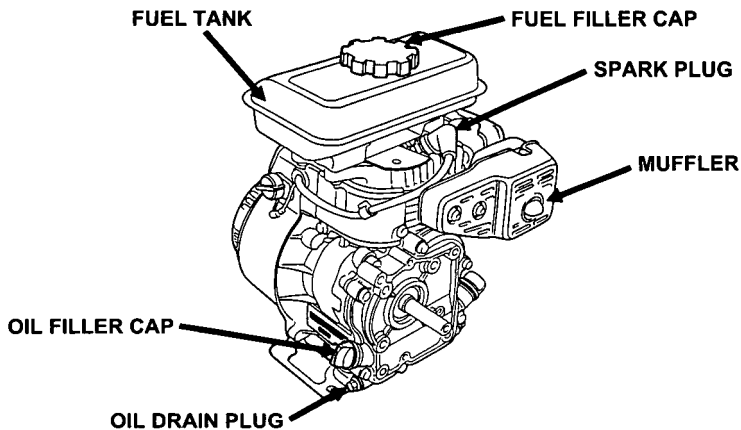
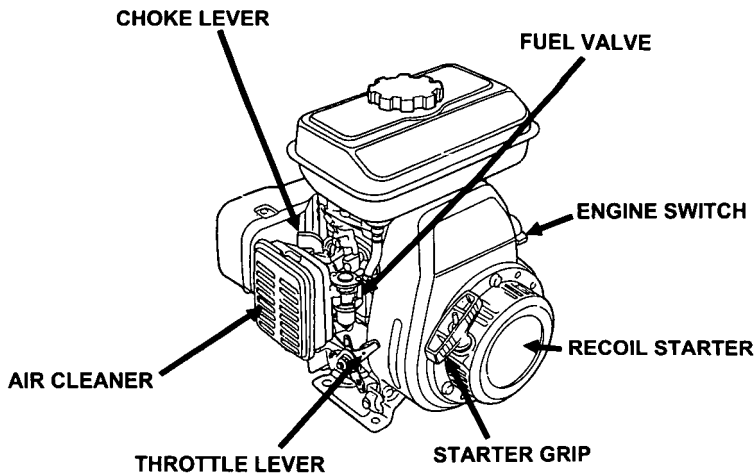

BEFORE OPERATION CHECKS

IS YOUR ENGINE READY TO GO?

For your safety, and to maximize the service life of your equipment, it is very important to take a few moments before you operate the engine to check its condition. Be sure to take care of any problem you find, or have your servicing dealer correct it, before you operate the engine.

WARNING

Improperly maintaining this engine, or failure to correct a problem before operation, can cause a malfunction in which you can be seriously hurt or killed.

Always perform a preoperation inspection before each operation, and correct any problem.

Before beginning your preoperation checks, be sure the engine is level and the engine switch is the OFF position.

Always check the following items before you start the engine:

1. Fuel level (see page 13).
2. Oil level (see page 14).
3. Air cleaner (see page 16).
4. General inspection: Check for fluid leaks and loose or damaged parts.
5. Check the equipment powered by this engine.

Review the instructions provided with the equipment powered by this engine for any precautions and procedures that should be followed before engine startup.

OPERATION

SAFE OPERATING PRECAUTIONS

Before operating the engine for the first time, please review the *SAFETY INFORMATION* section on page 3 and the *BEFORE OPERATION CHECKS* section on page 5.

WARNING

Carbon monoxide gas is toxic. Breathing it can cause unconsciousness and even kill you.

Avoid any areas or actions that expose you to carbon monoxide.

Review the instructions provided with the equipment powered by this engine for any safety precautions that should be observed with engine startup, shutdown, or operation.

STARTING THE ENGINE

1. Turn the fuel valve to the ON position.

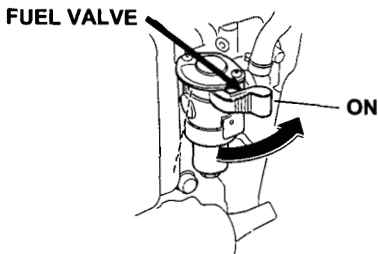

2. Turn the engine switch to the ON position.

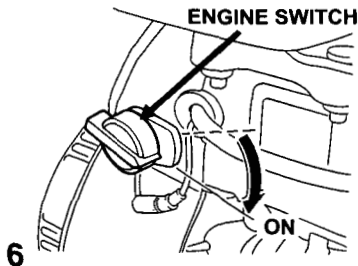

3. Move the throttle lever down slightly.

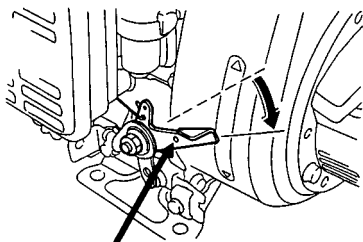

THROTTLE LEVER

4. FOR STARTING A COLD ENGINE:
Move the choke lever to CLOSE position.

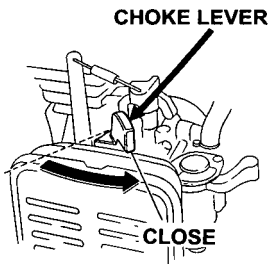

5. FOR RESTARTING A WARM ENGINE:
Do not use the choke when the engine is warm or the air temperature is high.

6. Pull the starter grip lightly until resistance is felt, then pull briskly.

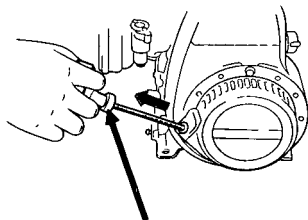

STARTER GRIP

NOTICE

*Do not allow the starter grip to snap back against the engine.
Return it gently to prevent damage to the starter.*

7. If the choke was used to start the engine, move the choke lever to the open position as soon as the engine warms up enough to run smoothly without use of the choke.

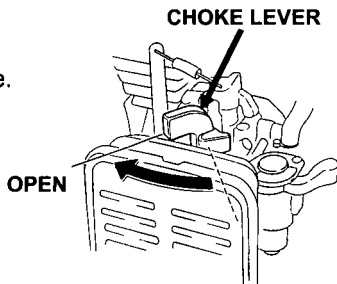

SETTING ENGINE SPEED

Position the throttle lever for the desired engine speed.

Some engine applications use a remotely-mounted throttle control rather than the engine-mounted throttle lever shown here.

For engine speed recommendations, refer to the instructions provided with the equipment powered by this engine.

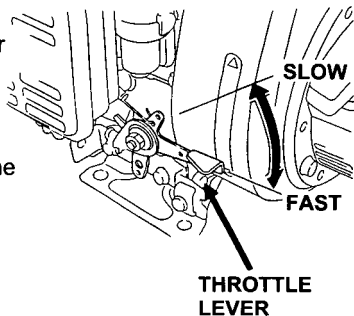

STOPPING THE ENGINE

To stop the engine in an emergency, turn the engine switch to the OFF position. Under normal conditions, use the following procedure.

1. Move the throttle lever up fully. Some engine applications use remotely-mounted throttle control rather than the engine-mounted throttle lever shown here.

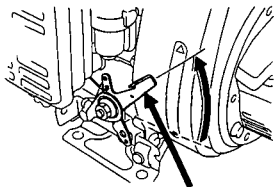

THROTTLE LEVER

2. Turn the engine switch to the OFF position.

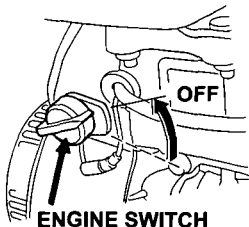

ENGINE SWITCH

3. Turn the fuel valve to the OFF position.

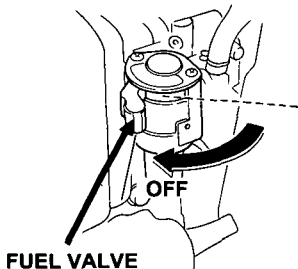

FUEL VALVE

SERVICING YOUR HONDA ENGINE

THE IMPORTANCE OF MAINTENANCE

Good maintenance is essential for safe, economical and trouble-free operation. It will also help reduce pollution.

WARNING

Improper maintenance, or failure to correct a problem before operation, can cause a malfunction in which you can be seriously hurt or killed.

Always follow the inspection and maintenance recommendations and schedules in this owner's manual.

To help you properly care for your engine, the following pages include a maintenance schedule, routine inspection procedures, and simple maintenance procedures using basic hand tools. Other service tasks that are more difficult, or require special tools, are best handled by professionals and are normally performed by a Honda technician or other qualified mechanic.

The maintenance schedule applies to normal operating conditions. If you operate your engine under severe conditions, such as sustained high-load or high-temperature operation, or use in unusually wet or dusty conditions, consult your servicing dealer for recommendations applicable to your individual needs and use.

Maintenance, replacement, or repair of the emission control devices and systems may be performed by any engine repair establishment or individual, using parts that are “certified” to EPA standards.

MAINTENANCE SAFETY

Some of the most important safety precautions follow. However, we cannot warn you of every conceivable hazard that can arise in performing maintenance. Only you can decide whether or not you should perform a given task.

WARNING

Failure to properly follow maintenance instructions and precautions can cause you to be seriously hurt or killed.

Always follow the procedures and precautions in this owner's manual.

SAFETY PRECAUTIONS

- Make sure the engine is off before you begin any maintenance or repairs. This will eliminate several potential hazards:
 - **Carbon monoxide poisoning from engine exhaust.**
Be sure there is adequate ventilation whenever you operate the engine.
 - **Burns from hot parts.**
Let the engine and exhaust system cool before touching.
 - **Injury from moving parts.**
Do not run the engine unless instructed to do so.
- Read the instructions before you begin, and make sure you have the tools and skills required.
- To reduce the possibility of fire or explosion, be careful when working around gasoline. Use only a nonflammable solvent, not gasoline, to clean parts. Keep cigarettes, sparks and flames away from all fuel related parts.

Remember that an authorized Honda servicing dealer knows your engine best and is fully equipped to maintain and repair it.

To ensure the best quality and reliability, use only new genuine Honda parts or their equivalents for repair and replacement.

MAINTENANCE SCHEDULE

REGULAR SERVICE PERIOD (3) Perform at every indicated month or operating hour interval whichever comes first.		Before each use	First month or 20hrs	Every 3 months or 50 hrs	Every 6 months or 100 hrs	Every year or 200 hrs	Refer to page	
ITEM								
• Engine oil	Check level	○					14	
	Change		○		○		15	
• Air cleaner	Check	○					16	
	Clean			○(1)				
• Spark plug	Check-readjust				○		17	
	Replace					○		
• Sediment cup	Clean				○		19	
• Spark arrester	Clean				○		20	
• Idle speed	Check-adjust					○(2)	—	
• Combustion chamber	Clean				○(2) (Every 1 year after or 125hrs)		—	
• Valve Clearance	Adjust				○(2) (Every year or 100hrs)		—	
• Fuel tank & filter	Clean					○(2)	—	
• Fuel line	Check	Every 2 years (Replace if necessary) (2)						—

• Emission related items

- (1) Service more frequently when used in dusty areas.
- (2) These items should be serviced by your servicing dealer, unless you have the proper tools and are mechanically proficient. Refer to Honda shop manual for service procedures.
- (3) For commercial use, log hours of operation to determine proper maintenance intervals.

REFUELING

Use unleaded gasoline with a pump octane rating of 86 or higher. This engine is certified to operate on unleaded gasoline. Unleaded gasoline produces fewer engine and spark plug deposits and extends exhaust system life.

⚠ WARNING

Gasoline is highly flammable and explosive, and you can be burned or seriously injured when refueling.

- Stop engine and keep heat, sparks, and flame away.
- Handle fuel only outdoors.
- Wipe up spills immediately.

NOTICE

Fuel can damage paint and some types of plastic. Be careful not to spill fuel when filling your fuel tank. Damage caused by spilled fuel is not covered under the Distributor's Limited Warranty.

Never use stale or contaminated gasoline or oil/gasoline mixture. Avoid getting dirt or water in the fuel tank.

Adding fuel

1. Remove the fuel tank cap.
2. Add fuel to the shoulder of the fuel strainer.

Do not overfill. Wipe up spilled fuel before starting the engine.

Fuel tank capacity: 1.4 l
(1.47 US qt)

**Do not fill above fuel
strainer shoulder**

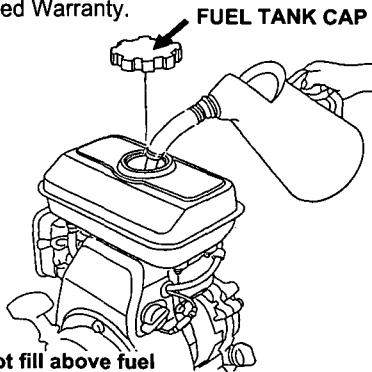
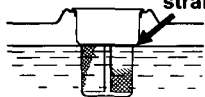

ENGINE OIL

Recommended Oil

Use 4-stroke motor oil that meets or exceeds the requirements for API service classification SJ. Always check the API SERVICE label on the oil container to be sure it includes the letters SJ.

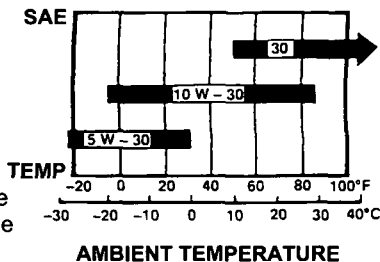

SAE 10W-30 is recommended for general use. Other viscosities shown in the chart may be used when the average temperature in your area is within the indicated range.

Oil Level Check

1. Check the oil level with the engine stopped and level.
2. Remove the oil filler cap/dipstick and wipe it clean.
3. Insert the oil filler cap/dipstick into the oil filler neck as shown, but do not screw it in, then remove it to check the oil level.
4. If the level is low, fill to the top of the oil filler neck with the recommended oil.
5. Reinstall the oil filler cap/dipstick.

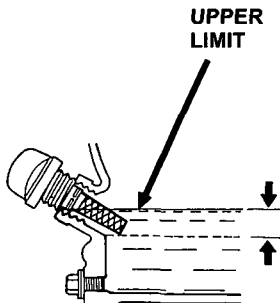
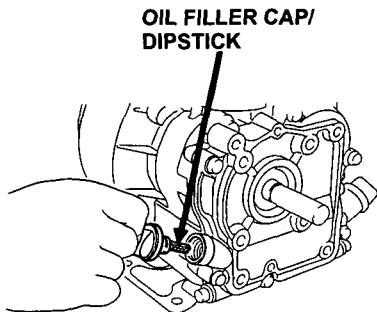

Oil Change

Drain the engine oil when the engine is warm. Warm oil drains quickly and completely.

1. Place a suitable container next to the oil drain bolt area.
2. Wipe the oil filler area clean, then remove the oil filler cap/dipstick.
3. Remove the oil drain bolt and sealing washer, and allow the oil to drain into a suitable container. After draining, install the drain bolt with the sealing washer and tighten it securely.

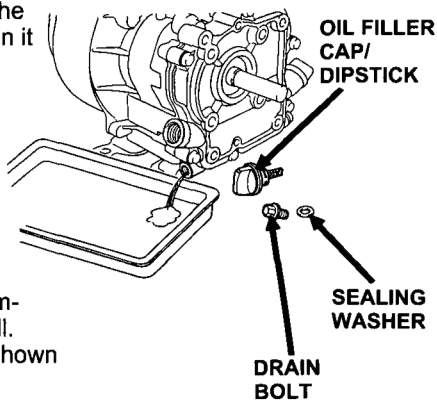

4. With the engine in a level position, fill with the recommended oil. Do not overfill. Measure the oil level as shown on page 14.

Engine oil capacity: 0.45 l (0.48 US qt)

Please dispose of used motor oil and the oil containers in a manner that is compatible with the environment. We suggest you take used oil in a sealed container to your local service station for reclamation. Do not throw it in the trash, pour it on the ground, or down a drain.

NOTICE

Running the engine with a low oil level can cause engine damage.

5. Reinstall the oil filler cap/dipstick securely.

AIR CLEANER

A dirty air cleaner will restrict air flow to the carburetor and cause poor engine performance. Inspect the filter element each time the engine is operated. You will need to clean the filter element more frequently than usual if you operate the engine in very dusty areas.

NOTICE

Operating the engine without a filter, or with damaged filter, will allow dirt to enter the engine, causing rapid engine wear. This type of damage is not covered under the Distributor's Limited Warranty.

Inspection

1. Remove the wing nut, then remove the air cleaner cover. Be careful to prevent dirt and debris from falling into the air cleaner base.
2. Remove the foam filter element from the air cleaner base.
3. Inspect the filter element. Replace a damaged filter. Clean or replace a dirty filter.

CLEANING

1. Clean the air filter with warm soapy water, rinse, and allow to dry thoroughly.
Or clean in nonflammable solvent and allow to dry.
2. Dip the filter in clean engine oil, then squeeze out all excess oil. The engine will smoke when started if too much oil is left in the foam.
3. Wipe dirt from the air cleaner body and cover, using a moist rag. Be careful to prevent dirt from entering the carburetor.

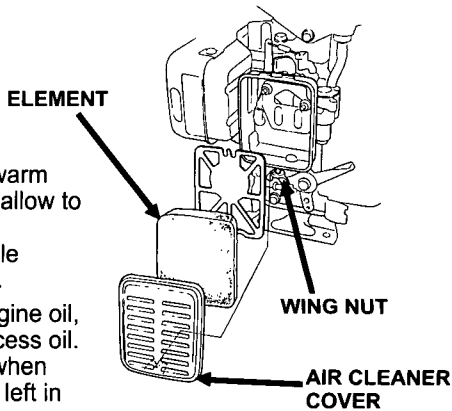

SPARK PLUG

Recommended Spark Plug: NGK BPMR-4A

The recommended spark plug is the correct heat range for normal engine operating temperatures.

NOTICE

Incorrect spark plug can cause engine damage.

For good performance, the spark plug must be properly gapped and free of deposits.

1. Disconnect the cap from the spark plug, and remove any dirt from the spark plug area.
2. Use the proper size spark plug wrench to remove the spark plug.
3. Inspect the spark plug. Replace it if damaged, badly fouled, if the sealing washer is in poor condition, or if the electrode is worn. If the spark plug is to be reused, clean it with a wire brush.
4. Measure the electrode gap with a suitable gauge. The correct gap is 0.6 – 0.7 mm (0.024 – 0.028 in). If adjustment is needed, correct the gap by carefully bending the side electrode.

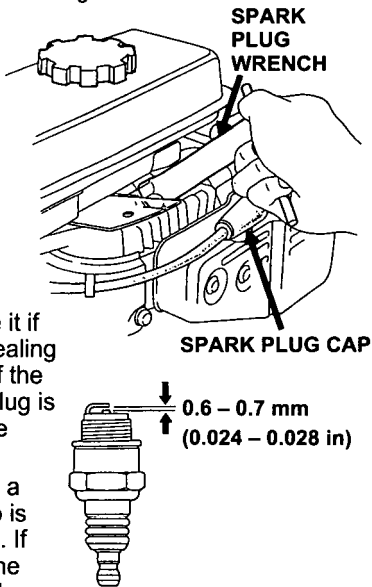

5. Install the spark plug carefully, by hand, to avoid cross-threading.
6. After the spark plug is seated, tighten with the proper size spark plug wrench to compress the washer.
7. When installing a new spark plug, tighten 1/2 turn after the spark plug seats to compress the washer.
8. When reinstalling the original spark plug, tighten 1/8 – 1/4 turn after the spark plug seats to compress the washer.

NOTICE

A loose spark plug can become very hot and can damage the engine. Overtightening the spark plug can damage the threads in the cylinder head.

9. Attach the spark plug cap to the spark plug.

SEDIMENT CUP CLEANING

1. Move the fuel valve to the OFF position, then remove the fuel sediment cup and O-ring.

⚠ WARNING

Gasoline is highly flammable and explosive, and you can be burned or seriously injured when handling fuel.

- Stop engine and keep heat, sparks, and flame away.
- Handle fuel only outdoors.
- Wipe up spills immediately.

2. Wash the sediment cup and O-ring in nonflammable solvent, and dry them thoroughly.
3. Place the O-ring in the fuel valve, and install the sediment cup. Tighten the sediment cup securely.
4. Move the fuel valve to the ON position, and check for leaks. Replace the O-ring if there is any leakage.

FUEL VALVE

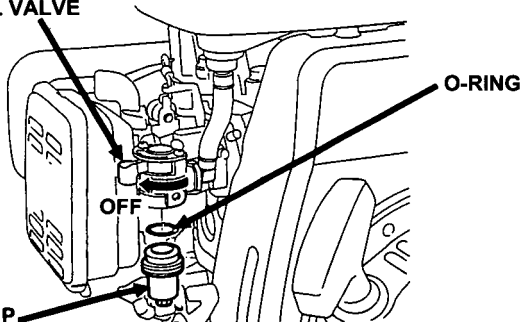

SEDIMENT CUP

SPARK ARRESTER (optional equipment)

In some areas, it is illegal to operate an engine without a USDA (United States Department of Agriculture)-qualified spark arrester. Check local laws and regulations. A USDA-qualified spark arrester is available from an authorized Honda servicing dealer.

The spark arrester must be serviced every 100 hours to keep it functioning as designed.

If the engine has been running, the muffler will be hot. Allow it to cool before servicing the spark arrester.

Spark Arrester Removal

1. Remove the two 6 mm nuts and the two screws and remove the muffler cover.
2. Remove the two tapping screws from the muffler deflector, and remove the muffler deflector, arrester plate and spark arrester.

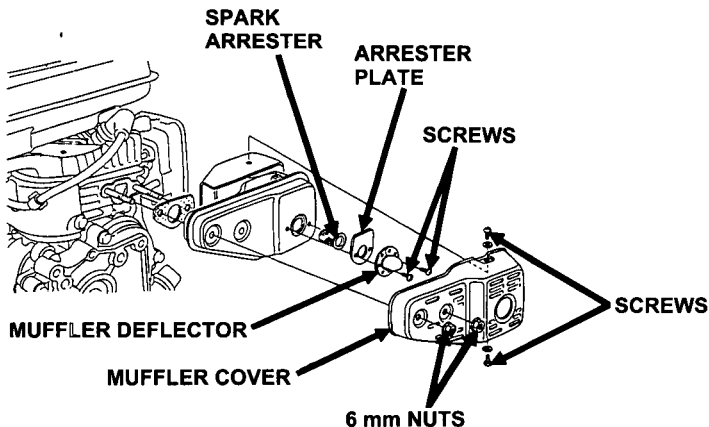

Spark Arrester Cleaning & Inspection

1. Use a brush to remove carbon deposits from the spark arrester screen. Be careful not to damage the screen. Replace the spark arrester if it has breaks or holes.
2. Install the spark arrester in the reverse order of removal.



HELPFUL TIPS & SUGGESTIONS

STORING YOUR ENGINE

Storage Preparation

Proper storage preparation is essential for keeping your engine troublefree and looking good. The following steps will help to keep rust and corrosion from impairing your engine's function and appearance, and will make the engine easier to start when you use it again.

Cleaning

If the engine has been running, allow it to cool for at least half an hour before cleaning. Clean all exterior surfaces, touch up any damaged paint, and coat other areas that may rust with a light film of oil.

NOTICE

Using a garden hose or pressure washing equipment can force water into the air cleaner or muffler opening. Water in the air cleaner will soak the air filter, and water that passes through the air filter or muffler, can enter the cylinder causing damage.

Fuel

Gasoline will oxidize and deteriorate in storage. Deteriorated gasoline will cause hard starting, and it leaves gum deposits that clog the fuel system. If the gasoline in your engine deteriorates during storage, you may need to have the carburetor, and other fuel system components, serviced or replaced.

The length of time that gasoline can be left in your fuel tank and carburetor without causing functional problems will vary with such factors as gasoline blend, your storage temperatures, and whether the fuel tank is partially or completely filled. The air in a partially filled fuel tank promotes fuel deterioration. Very warm storage temperatures accelerate fuel deterioration. Fuel problems may occur within a few months, or even less if the gasoline was not fresh when you filled the fuel tank.

Fuel system damage or engine performance problems resulting from neglected storage preparation are not covered under *the Distributor's Limited Warranty*.

You can extend fuel storage life by adding a gasoline stabilizer that is formulated for that purpose, or you can avoid fuel deterioration problems by draining the fuel tank and carburetor.

ADDING A GASOLINE STABILIZER TO EXTEND FUEL STORAGE LIFE

When adding a gasoline stabilizer, fill the fuel tank with fresh gasoline. If only partially filled, air in the tank will promote fuel deterioration during storage. If you keep a container of gasoline for refueling, be sure that it contains only fresh gasoline.

1. Add gasoline stabilizer following the manufacturer's instructions.
2. After adding a gasoline stabilizer, run the engine outdoors for 10 minutes to be sure that treated gasoline has replaced the untreated gasoline in the carburetor.
3. Stop the engine, and turn the fuel valve to the OFF position (see page 9).

DRAINING THE FUEL TANK AND CARBURETOR

⚠ WARNING

Gasoline is highly flammable and explosive, and you can be burned or seriously injured when handling fuel.

- Stop engine and keep heat, sparks, and flame away.
- Handle fuel only outdoors.
- Wipe up spills immediately.

1. With the fuel valve OFF, remove and empty the sediment cup.
2. Turn the fuel valve ON and drain the gasoline in the fuel tank into a suitable container.
3. Replace the sediment cup and tighten securely.
4. Drain the carburetor by loosening the drain screw. Drain the gasoline into a suitable container.

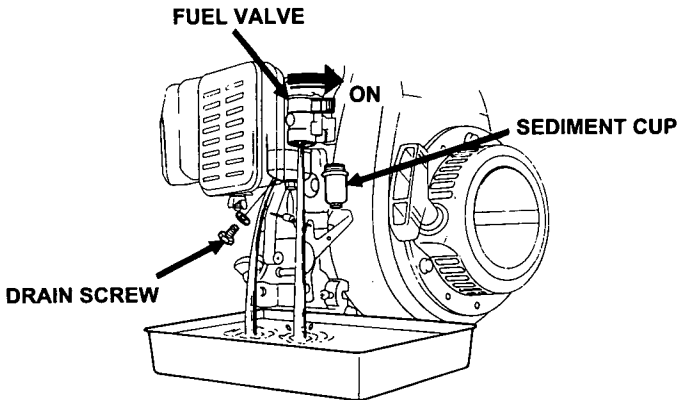

Engine oil

1. Change the engine oil (see page 15).
2. Remove the spark plug (see page 17).
3. Pour a tablespoon (5 – 10 cc) of clean engine oil into the cylinder.
4. Pull the recoil starter several times to distribute the oil.
5. Reinstall the spark plug.

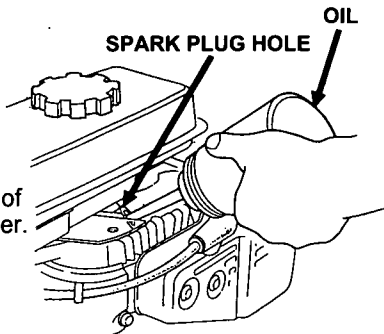

Storage Precautions

If your engine will be stored with gasoline in the fuel tank and carburetor, it is important to reduce the hazard of gasoline vapor ignition. Select a well-ventilated storage area away from any appliance that operates with a flame, such as a furnace, water heater, or clothes dryer. Also avoid any area with a spark-producing electric motor, or where power tools are operated.

If possible, avoid storage areas with high humidity, because that promotes rust and corrosion.

If there is gasoline in the fuel tank, leave the fuel valve in the OFF position (see page 9).

Keep the engine level in storage. Tilting can cause fuel or oil leakage.

With the engine and exhaust system cool, cover the engine to keep out dust. A hot engine and exhaust system can ignite or melt some materials. Do not use sheet plastic as a dust cover. A nonporous cover will trap moisture around the engine, promoting rust and corrosion.

Removal From Storage

Check your engine as described in the *BEFORE OPERATION CHECKS* section of this manual (see page 5).

If the fuel was drained during storage preparation, fill the tank with fresh gasoline. If you keep a container of gasoline for refueling, be sure it contains only fresh gasoline. Gasoline oxidizes and deteriorates over time, causing hard starting.

If the cylinder was coated with oil during storage preparation, the engine will smoke briefly at startup. This is normal.

TRANSPORTING

Keep the engine level when transporting to reduce the possibility of fuel leakage. Turn the fuel valve to the OFF position (see page 9).

TAKING CARE OF UNEXPECTED PROBLEMS

ENGINE WILL NOT START	POSSIBLE CAUSE	CORRECTION
1. Check choke lever position	Choke lever in wrong position.	Move choke lever to the CLOSE position unless engine is warm (p.7)
2. Check fuel.	Out of fuel.	Refuel (p.13)
	Fuel valve OFF.	Turn fuel valve ON.
	Bad fuel; engine stored without treating or draining gasoline, or refueled with bad gasoline.	Drain fuel tank and carburetor (p.22 and 23) Refuel with fresh gasoline (p.13).
3. Remove and inspect spark plug.	Spark plug faulty, fouled, or improperly gapped.	Clean, gap, or replace spark plug (p.17 and 18).
	Spark plug wet with fuel (flooded engine).	Dry and reinstall spark plug. Try to start the engine. (p.6, 7 and 8)
4. Take the Honda engine to a Honda engine dealer, or refer to shop manual.	Fuel filter clogged, carburetor malfunction, ignition malfunction, compression problem.	Replace or repair faulty components as necessary.
LOSS OF POWER	POSSIBLE CAUSE	CORRECTION
1. Check air filters.	Air filters clogged.	Clean or replace air filters (p.16)
2. Check fuel.	Bad fuel; engine stored without treating or draining gasoline, or refueled with bad gasoline.	Drain fuel tank and carburetor (p.22 and 23) Refuel with fresh gasoline (p.13).
3. Check throttle lever position.	Throttle lever in wrong position.	Position the throttle lever in fast position.
4. Take the engine to your servicing Honda engine dealer or refer to the shop manual.	Fuel filter clogged, carburetor malfunction, ignition malfunction, compression problem.	Replace or repair faulty components as necessary.

TECHNICAL & CONSUMER INFORMATION

TECHNICAL INFORMATION

Serial Number Location

Record the engine serial number in the space below. You will need this information when ordering parts and when making technical or warranty inquiries.

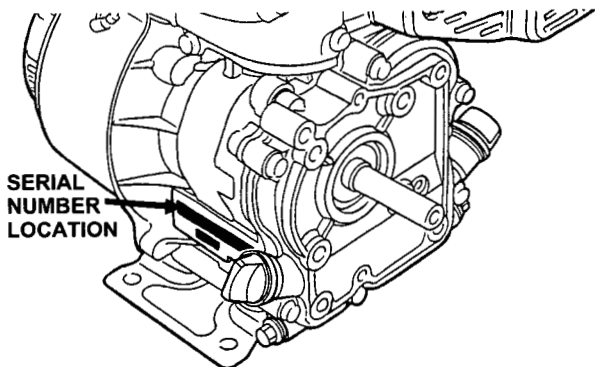

Engine serial number: **GJAE** - _____

Carburetor Modification For High Altitude Operation

At high altitude, the standard carburetor air-fuel mixture will be too rich. Performance will decrease, and fuel consumption will increase. A very rich mixture will also foul the spark plug and cause hard starting.

High altitude performance can be improved by specific modifications to the carburetor. If you always operate your engine at altitudes above 1,500 meters (5,000 feet) have an authorized Honda servicing dealer perform this carburetor modification.

Even with carburetor modification, engine horsepower will decrease about 3.5% for each 300 meter (1,000 foot) increase in altitude. The effect of altitude on horsepower will be greater than this if no carburetor modification is made.

NOTICE

When the carburetor has been modified for high altitude operation, the air-fuel mixture will be too lean for low altitude use. Operation at altitudes below 1,500 meters (5,000 feet) with a modified carburetor may cause the engine to overheat and result in serious engine damage. For use at low altitudes, have an authorized Honda servicing dealer return the carburetor to original factory specifications.

Oxygenated Fuels

Some conventional gasolines are being blended with alcohol or an ether compound. These gasolines are collectively referred to as oxygenated fuels. To meet clean air standards, some areas of the United States and Canada use oxygenated fuels to help reduce emissions.

If you use oxygenated fuel, be sure it is unleaded and meets the minimum octane rating requirements.

Before using an oxygenated fuel, try to confirm the fuel's contents. Some states/provinces require this information to be posted on the pump.

The following are the EPA approved percentages of oxygenates:

- ETHANOL** — (ethyl or grain alcohol) 10% by volume
You may use gasoline containing up to 10% ethanol by volume. Gasoline containing ethanol may be marketed under the name Gasohol.
- MTBE** — (methyl tertiary butyl ether) 15% by volume
You may use gasoline containing up to 15% MTBE by volume.
- METHANOL** — (methyl or wood alcohol) 5% by volume
You may use gasoline containing up to 5% methanol by volume as long as it also contains cosolvents and corrosion inhibitors to protect the fuel system. Gasoline containing more than 5% methanol by volume may cause starting and/or performance problems. It may also damage metal, rubber, and plastic parts of your fuel system.

If you notice any undesirable operating symptoms, try another service station or switch to another brand of gasoline.

Fuel system damage or performance problems resulting from the use of an oxygenated fuel containing more than the percentages of oxygenates mentioned above are not covered under the *Distributor's Limited Warranty*.

Emission Control System Information

Source of Emissions

The combustion process produces carbon monoxide, oxides of nitrogen, and hydrocarbons. Control of hydrocarbons and oxides of nitrogen is very important because, under certain conditions, they react to form photochemical smog when subjected to sunlight. Carbon monoxide does not react in the same way, but it is toxic.

Honda utilizes lean carburetor settings and other systems to reduce the emissions of carbon monoxide, oxides of nitrogen, and hydrocarbons.

The U.S. and California Clean Air Acts

EPA and California regulations require all manufacturers to furnish written instructions describing the operation and maintenance of emission control systems.

The following instructions and procedures must be followed in order to keep the emissions from your Honda engine within the emission standards.

Tampering and Altering

Tampering with or altering the emission control system may increase emissions beyond the legal limit. Among those acts that constitute tampering are:

- Removal or alteration of any part of the intake, fuel, or exhaust systems.
- Altering or defeating the governor linkage or speed-adjusting mechanism to cause the engine to operate outside its design parameters.

Problems That May Affect Emissions

If you are aware of any of the following symptoms, have your engine inspected and repaired by your servicing dealer.

- Hard starting or stalling after starting.
- Rough idle.
- Misfiring or backfiring under load.
- Afterburning (backfiring).
- Black exhaust smoke or high fuel consumption.

Replacement Parts

The emission control systems on your Honda engine were designed, built, and certified to conform with EPA and California emission regulations. We recommend the use of genuine Honda parts whenever you have maintenance done. These original-design replacement parts are manufactured to the same standards as the original parts, so you can be confident of their performance. The use of replacement parts that are not of the original design and quality may impair the effectiveness of your emission control system.

A manufacturer of an aftermarket part assumes the responsibility that the part will not adversely affect emission performance. The manufacturer or rebuilder of the part must certify that use of the part will not result in a failure of the engine to comply with emission regulations.

Maintenance

Follow the maintenance schedule on page 12. Remember that this schedule is based on the assumption that your machine will be used for its designed purpose. Sustained high-load or high-temperature operation, or use in unusually wet or dusty conditions, will require more frequent service.

Specifications

DIMENSIONS	G100K2 (QA Type)
Description code	G100
Length x Width x Height mm (in)	275 x 270 x 345 (10.8 x 10.6 x 13.6)
Dry Weight kg (lb)	8.7 (19.2)
Engine type	4-stroke, side valve, 1 cylinder
Displacement	98 cm ³ (6.0 cu in)
Bore x Stroke mm (in)	52 x 46 (20.5 x 18.1)
Maximum Output	2.5 hp at/4,200 rpm*
Maximum Torque	4.5 N·m (0.45 kg-m, 3.3 ft-lb) at/3000 rpm
Fuel Consumption	435 g/kWh (320g/PSH, 0.715 lb/hph)
Cooling system	Forced Air
Ignition system	Transistorized magneto
Lubrication System	Forced Splash
PTO Shaft Direction	Counterclockwise

* Rated speed is 3,600 rpm.

Specifications are subject to change without notice.

Tuneup Specifications

ITEM	SPECIFICATION	PAGE
Valve Clearance (cold)	0.08 – 0.16 mm (0.003 – 0.006 in)	See your servicing Honda engine dealer
Other specifications	No other adjustments needed.	

Quick Reference Information

Fuel	Type	Unleaded gasoline with a pump octane rating of 86 or higher (page 13).
	Capacity	1.4 ℓ (1.47 US qt)
Engine Oil	Type	SAE 10W-30, API SJ for general use, Refer to page 14.
	Capacity	0.45 ℓ (0.48 US qt)
Spark plug gap	Type	BPMR-4A (NGK)
	Gap	0.6 – 0.7 mm (0.24 – 0.28 in) Refer to page 16.

CONSUMER INFORMATION

Honda Publications

These publications will give you additional information for maintaining and repairing your engine. You may order them from an authorized Honda engine servicing dealer.

Shop Manual	This manual covers complete maintenance and overhaul procedures. It is intended to be used by a skilled technician.
Parts Catalog	This manual provides complete, illustrated parts lists.

Warranty Service Information

Honda engine dealership personnel are trained professionals. They should be able to answer any question you may have. If you encounter a problem that your dealer does not solve to your satisfaction, please discuss it with the dealership's management. The Service Manager or General Manager can help. Almost all problems are solved in this way.

If you are dissatisfied with the decision made by the dealership's management, contact the Honda Power Equipment Customer Service Office. You can write:

American Honda Motor Co., Inc.
Power Equipment Division
Customer Relations Office
4900 Marconi Drive
Alpharetta, GA 30005-8847

Or telephone: (770) 497-6400, M-F, 8:30 am - 5:00 pm EST

When you write or call, please give us this information:

- Model and serial numbers (see page 26)
- Name of the dealer who sold the engine to you
- Name and address of the dealer who services your engine
- Date of purchase
- Your name, address, and telephone number
- A detailed description of the problem