

24" LCD TV 1080p

# QUICK SETUP GUIDE

DX-24L200A12

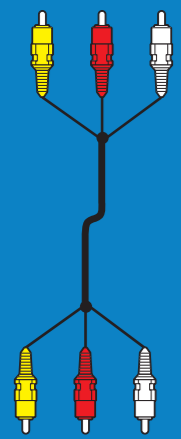

AV cable



Remote control and two AAA batteries



TV stand

## Front features



## Installing the stand

- Carefully place your TV screen face-down on a cushioned, clean surface to protect the screen from damages and scratches.
- Align the stand with the column and twist the stand in the direction of the arrow until you hear it snap into place.

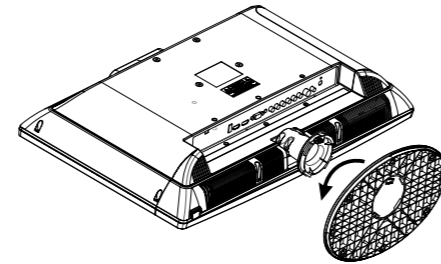

## Installing a wall-mount bracket

- Carefully place your TV screen face-down on a cushioned, clean surface to protect the screen from damages and scratches.
- Press the **PUSH** button, then rotate the stand to remove it.
- Remove the six screws that secure the stand column, then remove the column.

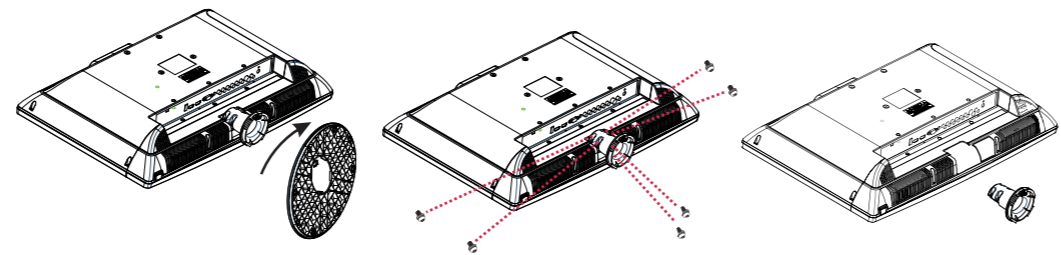

- Attach the wall-mount bracket to your TV using the mounting holes on the back of your TV. See the instructions that came with the wall-mount bracket for information about how to correctly hang your TV.

### Warning

This apparatus is intended to be supported by a UL Listed wall mount bracket.

## Identifying cables

Your TV has several connection types for connecting devices. For the best video quality, connect a device to the best available connection.

Connection type	Video quality	Cable connector
HDMI video/audio	Best	
OR		
Component video and analog audio	Better	
OR		
Composite video and analog audio	Good	

You can use an HDMI jack to connect a DVI device to your TV. You need to attach an HDMI 1-to-DVI adapter to the end of the HDMI cable that connects to the DVI device's jack.

## Connecting a DVD or Blu-ray player, cable box, satellite receiver, or game station

Using HDMI (best)

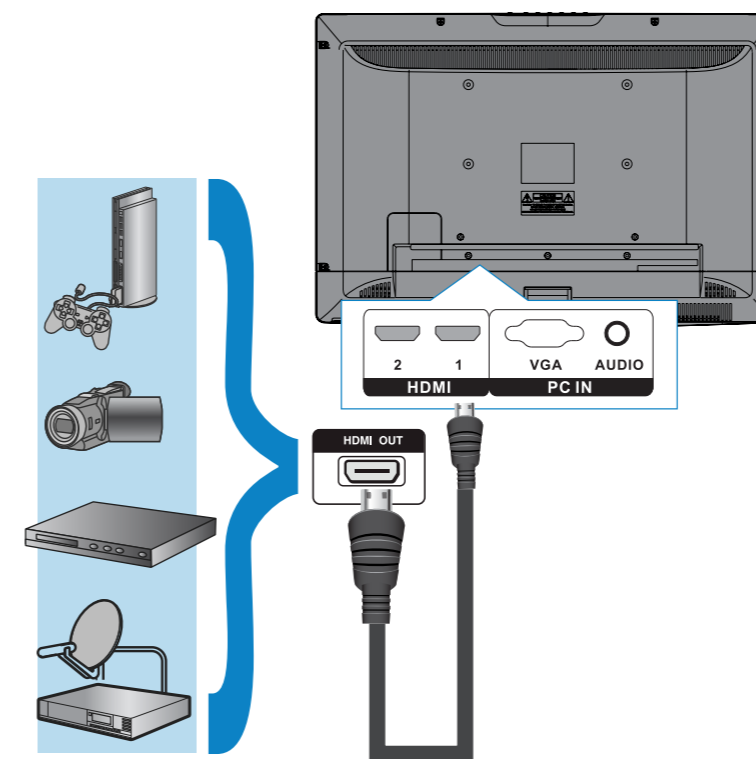

Using component cables (better)

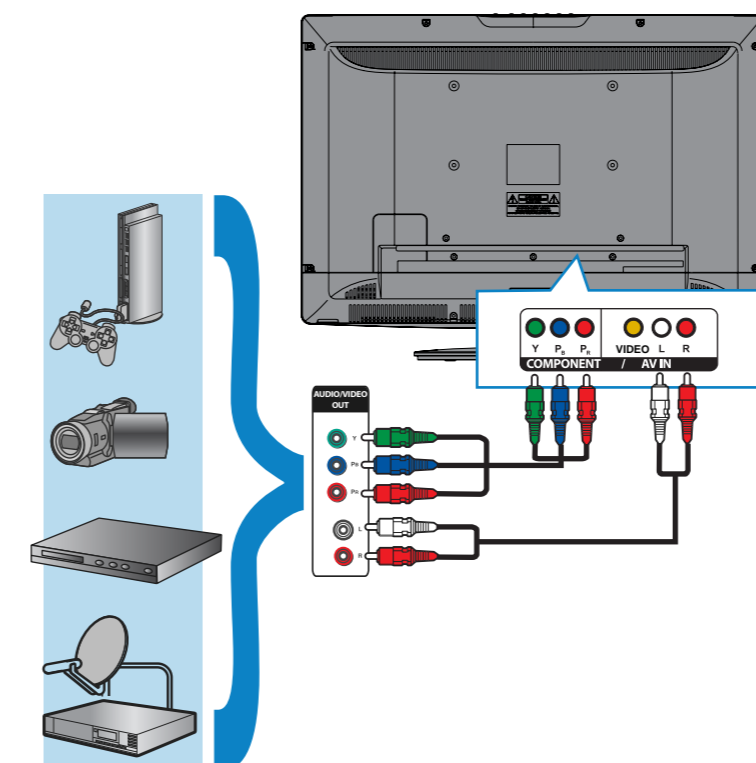

Using composite cables (good)

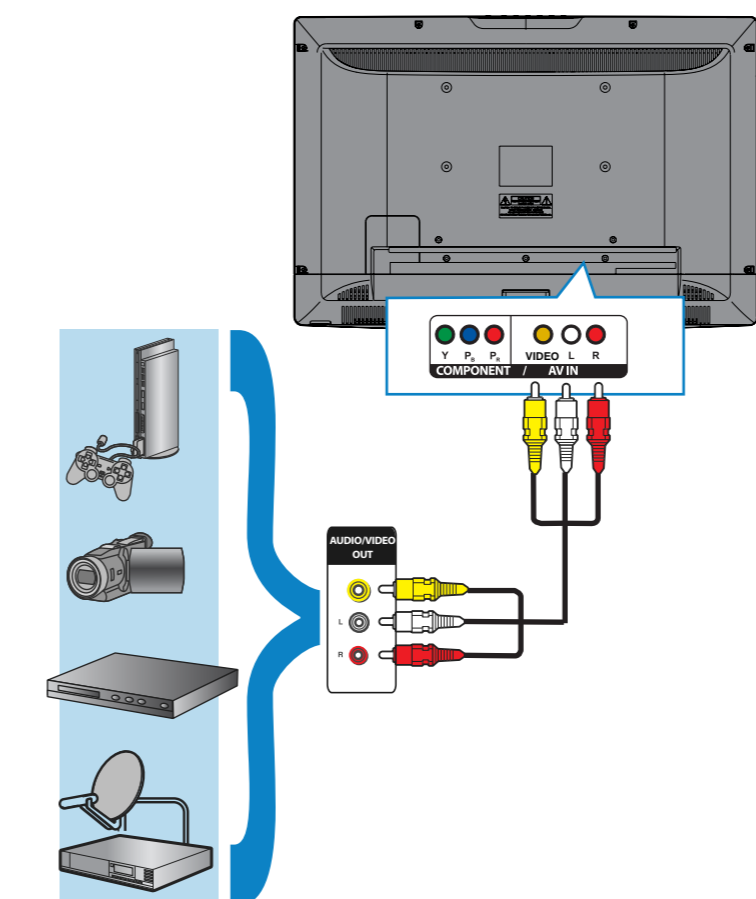

## Connecting an antenna/cable wall jack

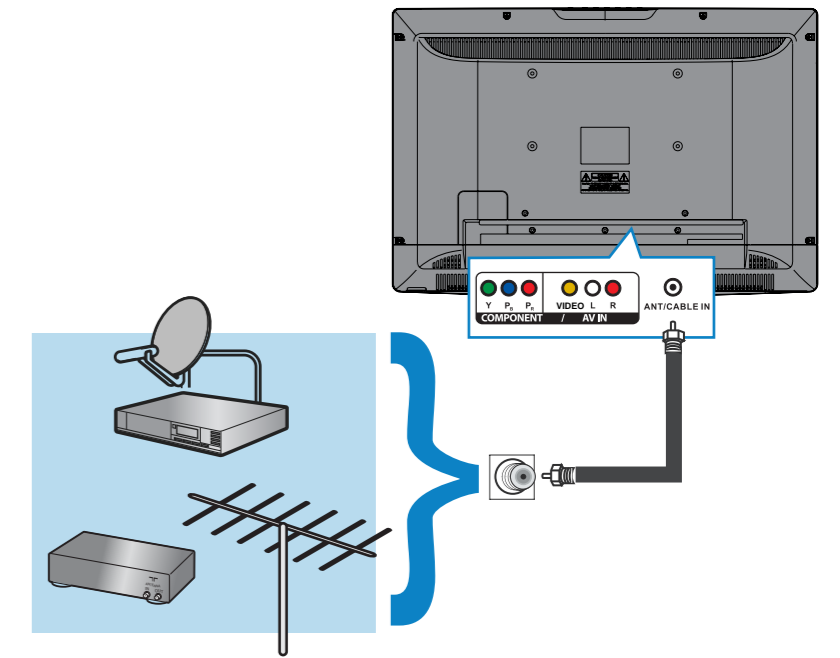

## Connecting a Home Theater System

Using digital audio

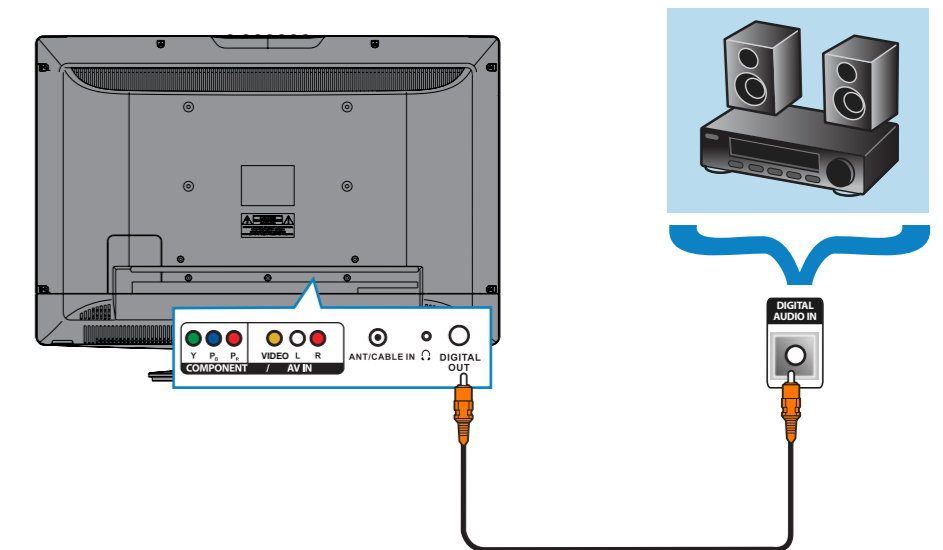

## Connecting a home theater system with multiple devices

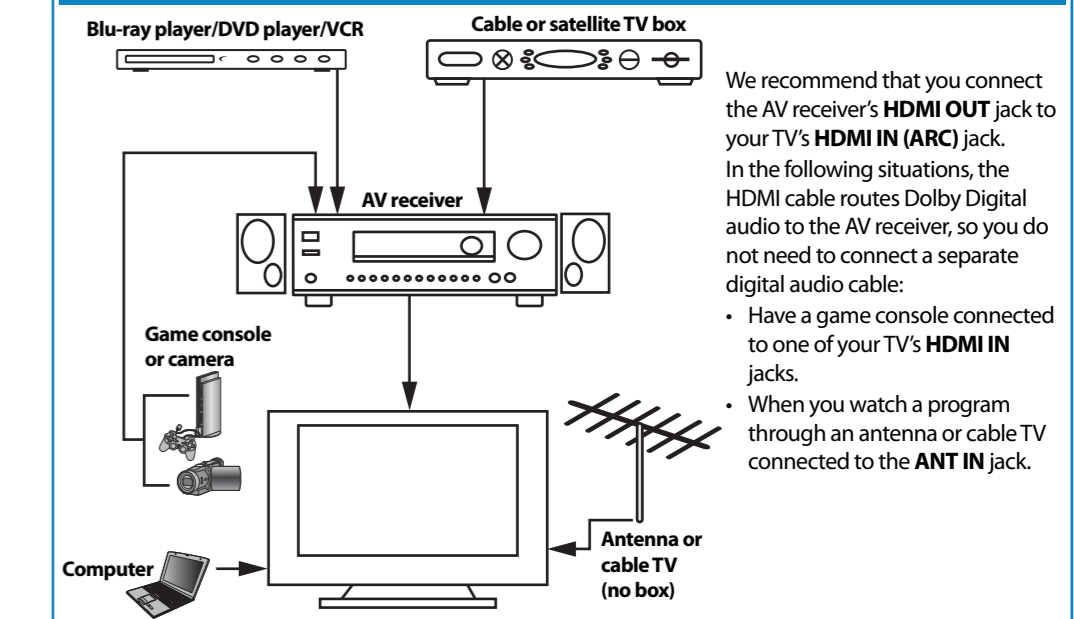

## WE ARE GOING GREEN!

A copy of your *User Guide* is not provided in the box but is available online. Go to [www.dynexproducts.com](http://www.dynexproducts.com), click **Support & Service**. Enter your model number in the **Search** field, then press **Enter**. Click **Support/Downloads**.



## Setting up and using your remote control

- 1 Press the release button on the back of the remote to remove the battery compartment cover.
- 2 Insert two AAA batteries into the battery compartment. Make sure that the + and - symbols on the batteries match the + and - symbols in the battery compartment.
- 3 Replace the cover.

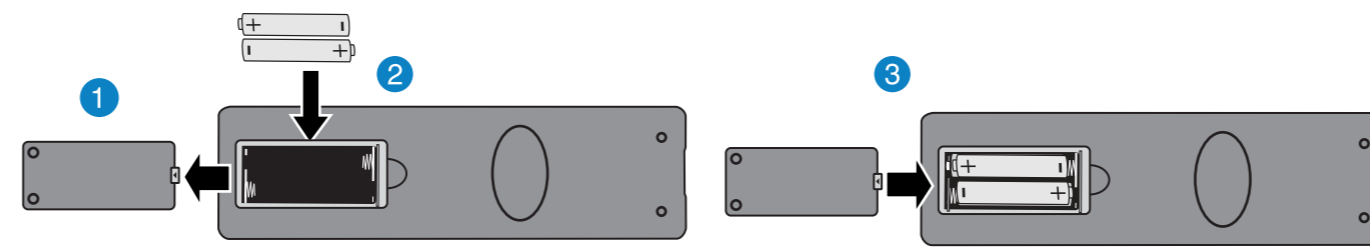

**INPUT**  
Opens the Input Source list.

**Power**  
Turns your TV on or off.

**Numbers**  
Enter channel numbers.

**INFO**  
Opens a TV status banner.

**RECALL**  
Returns to the previous channel.

**GUIDE**  
Displays the program guide.

**ENTER**  
Confirms selections or changes.

**Arrows**  
Navigates in on-screen menus.

**MENU**  
Opens the on-screen menu.

**EXIT**  
Closes the on-screen menu.

**MUTE**  
Mutes the sound.

**Volume**  
Changes the volume.

**Channel**  
Changes the TV channels.

**Quick Launch Inputs**  
Selects another source connected to your TV.

**FAVORITE**  
Opens the Favorite Channel List.

**ZOOM**  
Changes how the picture displays on the screen.

**MTS/SAP**  
Cycles through mono, stereo, and secondary audio for analog programs.

**PICTURE**  
Selects the picture modes.

**CH-LIST**  
Opens the channel list.

**SLEEP**  
Sets the sleep timer.

**CCD**  
Turns closed captioning on or off.

**AUDIO**  
Selects the audio modes.

**INPUT SOURCE**  
TV  
AV  
Component  
HDMI1  
HDMI2  
VGA

**Aspect ratio options**

- Normal:** Displays the original 4:3 aspect ratio with black bars vertical on the left and right hand side of the screen.
- Zoom:** Expands the image to fill the screen. The top and bottom of the image may be cropped.
- Wide:** Use this option to view content recorded in a 16:9 (wide-screen) aspect ratio.
- Cinema:** Stretches the image at the edges, but keeps a clear image in the center.
- Auto:** Automatically adjusts the image based on the screen size and the TV program. **Note:** Auto is only available when Auto Zoom in the Channels menu is set to On.

## Programming your remote control

To program your universal remote control to work with your new Dynex TV, see the table for common codes. If you have problems programming your remote or need a different remote control code, visit <http://www.dynexproducts.com/remotecodes> for the latest remote control code information.

Universal remote TV codes												
Universal remote controls				Cable/Satellite/Set-top box								
One for All	Philips	RCA	Sony	Cablevision	Charter	Comcast	Cox	DirectTV	Dish Network	Time Warner	TiVo	Verizon
0054	0198, 0490	135	068, 069, 078, 096, 100, 164, 168, 229, 026	068, 069, 078, 096, 100, 164, 168, 229, 026	2002, 1204, 1423, 1517, 0171, 1963, 0463, 1463, 0842, 1326, 167, 415, 424, 450, 456, 461, 507, 523, 567, 577, 586	10171, 11204, 11326, 11463, 11517, 11641, 11780, 11785, 11892, 11963, 12002	1326, 1463	10171, 11204, 11326, 11517, 11564, 11641, 11963, 12002	720	400, 450, 461, 456, 10463, 1463, 0463	0091	0198, 0490

## Connecting power

Plug the TV power cord into an AC wall outlet.

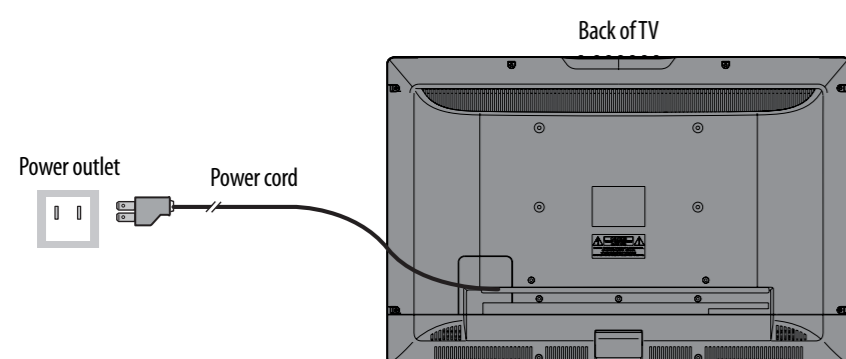

## Turning on your TV for the first time

- 1 Press **Power**, then wait several seconds. The *Choose your menu language* screen opens.
- 2 Press **Up** or **Down** to highlight a language, then press **ENTER**. The *Time* screen opens with Mode highlighted.
- 3 Press **Left** or **Right** to select **Auto** or **Custom**. If you select **Auto**, the date and time are set automatically from a digital TV signal. If you select **Custom**, you can manually set the date and time. Press **ENTER**. The *Choose your Picture Mode* screen opens.
- 4 Press **Up** or **Down** to highlight **Home Mode** or **Retail Mode**, then press **ENTER**. If you select **Retail Mode**, a message asks you to confirm your selection. Select **Yes** or **No**. **Retail Mode** is not an energy-saving mode. The *Choose your TV source* screen opens.
- 5 Press **Up** or **Down** to highlight **Antenna**, **Cable**, or **Cable/Satellite box**. If you select **Antenna** or **Cable**, your TV scans for available channels. The scan may take several minutes. **If you select Cable/Satellite box, your TV does not scan for channels.**
- 6 To watch TV, press **INPUT**, then press **Up** or **Down** to select the video input source for your TV signal. For example, select **HDMI** if your TV is connected to a cable/satellite box using an HDMI cable or select **TV** if your TV is connected to an antenna or cable/satellite using a coaxial cable.

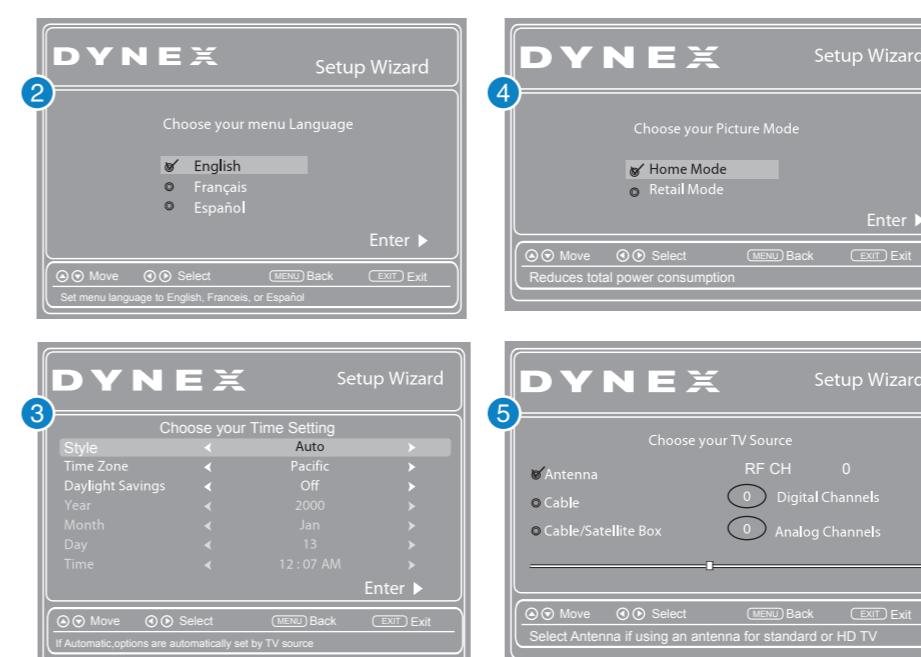

# DYNEX

## One-year limited warranty

Visit [www.dynexproducts.com](http://www.dynexproducts.com) for details.

## Need additional help?

See your *User Guide*! This comprehensive guide includes everything from basic how-to steps to more advanced features. Go to [www.dynexproducts.com](http://www.dynexproducts.com), click **Support & Service**. Enter your model number in the **Search** field, then press **Enter**. Click **Support/Downloads**.

## We're here for you

[www.dynexproducts.com](http://www.dynexproducts.com)  
For customer service, call:  
**800-305-2204 (U.S./Canada markets)**

Distributed by Best Buy Purchasing, LLC  
7601 Penn Avenue South, Richfield, MN USA 55423-3645

© 2011 BBY Solutions, Inc., All Rights Reserved.  
DYNEX is a trademark of BBY Solutions, Inc. Registered in some countries. All other products and brand names are trademarks of their respective owners.