

Beacon IITM

REFRIGERATION SYSTEM

H-IM-79D

February, 2004

Part Number 25001401

Replaces H-IM-79C (12/03)

Installation & Operation Manual



Beacon II Board layout	3
Installation Tips	4
Brazing Power Supply Wiring	5
Multiple Evaporator Configuration	6
Box Temperature control setting Leak Testing Refrigerant Charging	7
Start Up Operation	8-11
Operating Mode Display	11
Programming and reviewing settings and changes	12-13
Program review button Select button Enter button	
Monitoring Items	14
Monitor button Force Defrost button Force Service button Reset Time button Clear/Test button	
Locking Beacon II board	15
Status Indicator LED	15-16
Low Ambient Operation	16
Pumpdown	16-17
Defrost	17-18
Alarms	18
Error Indicator Evaporator fans shutdown by operators	19
Checking Operation of Expansion valve	20-21
Power Failures Service Mode Spare Sensor Terminals Checking sensors	21
Sensor resistance/temperature table System Defaults	22
Parts List Operational limits	23
Expansion Valve Capacity Diagnostics	24-27
Wiring diagrams	28-33
Preventive Maintenance	34
Service Record	35-36

BEACON II BOARD

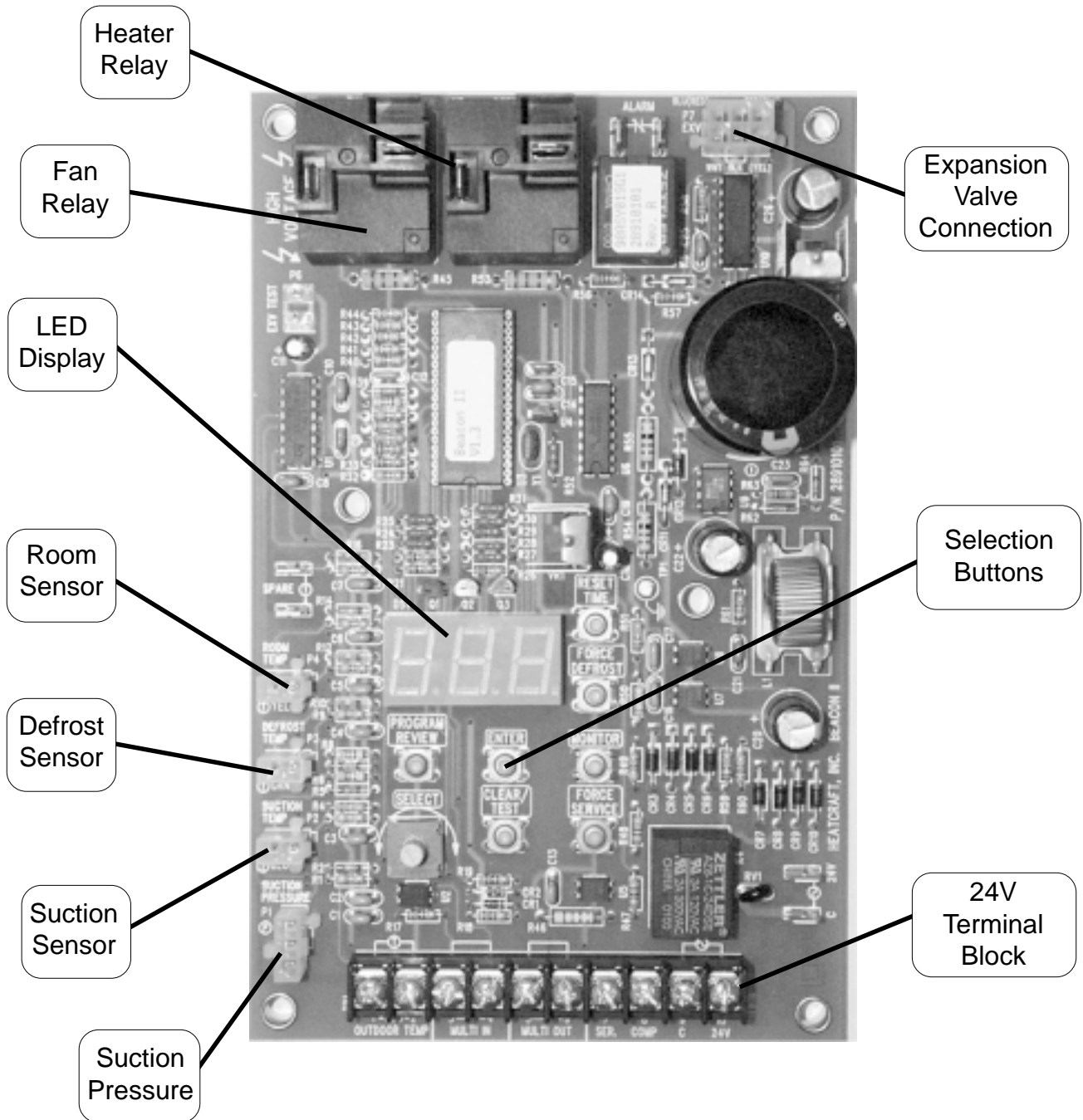

Installation Tips

- Use a minimum 18 gauge wire for all low voltage connections.
- The Beacon II board gets its 24 VAC power supply from a transformer mounted in the electrical end of each evaporator. On 208-240 volt systems the multi-tap transformer is shipped from our factory wired for 240 volts. If your supply voltage is 208 volt you must change to the 208 volt tap on the transformer.
Note: On multiple evaporators, since a transformer is in each evaporator, the voltage tap must be set on each evaporator.
- Refer to wiring schematic shipped on units for unit wiring. Schematics in this Installation & Operation Manual are typical wiring schematics only.
- Program ALL slave evaporators as SLAVES.
- Evaporators are shipped from our factory with a preset box setpoint temperature of 35°F for air defrost and -10°F for electric defrost. If your box setpoint temperature requirements are different this must be set using directions outlined under “Room Temperature Control”.
- The suction line temperature sensor MUST be removed from the suction line before brazing the suction tubing. The sensor MUST then be reinstalled on the suction line after brazing is completed and the tubing has cooled. Insulate when finished.
- The low pressure switch time delay relay, located in the condensing unit, must be set to 1 minute.
- If electrical power will be connected prior to evacuation and charging of system, unplug electric expansion valve from board until system is ready to be evacuated, leak tested and charged.
- Some systems may require the crankcase heater be energized 24 hours prior to start-up. The Beacon should be de-energized for this period by placing it in the SERVICE MODE. This is done by pressing the “FORCE SERVICE” button twice. To start the system cooling, press the “CLEAR” button.
- Room sensors must be left connected on ALL evaporators.
- A pressure transducer is installed on the evaporator. Do not leak test system above 150 PSI or damage to transducer could occur. If leak testing must be greater than 150 psig, disconnect the transducer from the suction header and reconnect after testing is complete.

CONDENSING UNIT

The condensing unit control panel contains the relays, contactors, time delay and a terminal block which is appropriately marked to match the low voltage wiring connections. A sensor for outdoor air temperature measurement is installed on the condensing unit.

Condensing unit must be installed using proper refrigeration practices and codes. Make sure there is sufficient clearances around unit for adequate air flow and access.

EVAPORATOR UNIT

The evaporator contains the Beacon II controller, electric expansion valve, pressure transducer, distributor, orifice, transformer and three sensors. These components are all factory mounted and wired. The three sensors are factory mounted and provide input to the controller from the following: defrost temp., suction temp., room temp.

Each evaporator unit must be installed using proper refrigeration practices and codes. Make sure the piping is correctly sized and properly routed. It is highly recommended that the liquid and suction lines be insulated. There must also be good clearance around unit. See Heatcraft Refrigeration Installation & Operation Manual for more details.

Refrigerant Line Brazing (**CAUTION**)

The electric expansion valve and the suction temperature sensor on the suction line are factory installed. Care must be taken when brazing these lines at the evaporator. ***Too high a temperature may destroy these components. Heat absorbing compounds or “wet rags” must be used to protect the electric expansion valve when brazing the refrigerant line connections. The suction line sensor should be removed before brazing.***

POWER SUPPLY

The Beacon II board gets its 24 VAC power supply from a transformer mounted in the electrical end of each evaporator. On 208-240 volt systems the multi-tap transformer is shipped from our factory wired for 240 volts. If your supply voltage is 208 volt you must change to the 208 volt tap on the transformer.

VERY IMPORTANT: If the supply voltage to the evaporator is 208 volts, the primary tap of the transformer must be moved to the 208 volt tap. ***This must be done for all the evaporators on that system.***

If the 24 VAC power supply falls below 18 VAC the system may power down and shut off. When the power supply is corrected to 24 VAC the system will restart after the four minute hold-off period and resume normal operation.

On Beacon II systems the main power for the evaporator can be supplied separately from the power supply of the condensing unit. All wiring, however, must comply with local electrical codes.

WIRING

Wiring between the condensing unit and the unit cooler(s) will be as follows (see wiring diagrams):

- High voltage - There may be high voltage on the defrost heater relay and the fan relay. The evaporator may also be connected to a separate power supply from the condensing unit. See unit cooler spec. plate for ampacity.
- Low voltage - 24V Class II control circuit. A total of five low voltage leads are required to connect the condensing unit to the evaporator. (See wiring diagram.) Two of these leads are for connecting the outdoor temperature sensor. The other three leads are for connecting the compressor relay, service relay and 24V Common inputs. ***All 24 volt wiring must be run separate from the line voltage wiring.***
- Low voltage wiring must be 18 gauge minimum. For low voltage wiring, maximum distances are:

Condensing unit to Master evaporator	500 ft.
Between evaporators	500 ft.
Smart Controller to Master evaporator	1000 ft.

WIRING (cont'd.)

- Multiple units – The *multi-in* and *multi-out* are the communication connections. Connection sequence must follow the *multi-out* terminal to the *multi-in* terminal and the *multi-out* back to the *multi-in* terminal in a daisy chain loop.
- Alarm circuit - The onboard alarm is a dry set of NC contacts which closes to indicate an alarm. The type and wiring for the alarm is customer specified. Note that the alarm circuit does not distinguish or indicate what has caused the alarm.
- All wiring must comply with all applicable codes and ordinances.

MULTIPLE EVAPORATOR CONFIGURATION (Master/Slave)

If there are multiple evaporators on a system, the program for each SLAVE evaporator must be changed to identify it as a SLAVE. To do so, press the “PROGRAM REVIEW” button repeatedly until “SLA” appears then use the “SELECT” knob to select “YES” then press “ENTER”. All Beacon II boards are shipped with the factory default as a “MASTER” evaporator. Place all boards in the “Service” mode while you program the setpoints to avoid errors and alarms which may cause troubles at startup.

VERY IMPORTANT: This must be done for each slave board.



Up to 4 evaporators can be connected as a master/slave configuration. **DO NOT remove the room sensor from any of the Beacon II boards.** This also applies when connected to the optional Smart Controller.

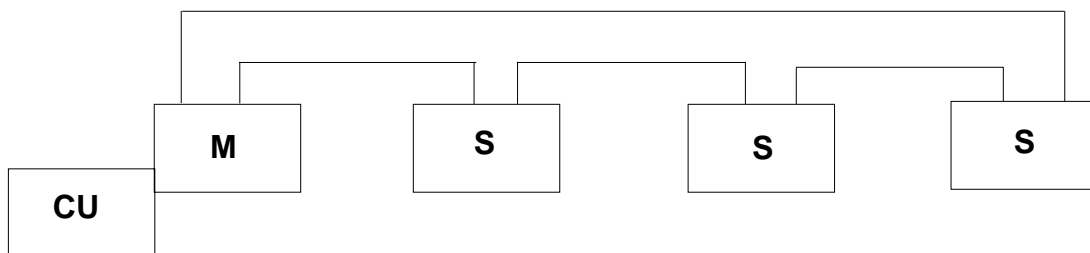

M = Master Evaporator **S** = Slave Evaporator **CU** = Condensing Unit

Each Beacon II board power is supplied by a transformer in the evaporator on which it is mounted. Do not run any 24 VAC wires between Beacon II boards on the evaporators.



Box Temp Control Settings

BOX TEMPERATURE CONTROL SETTINGS

- There is an on board **room thermostat** on the Beacon II board which can be adjusted to the desired room temperature. The temperature differential is 2° F.

Temperature Differential

When a system is in the cooling mode and the box setpoint is 35°F, the system will continue to cool until the box temperature gets to 34°F. At this point the compressor will pumpdown and shut off. The system will restart cooling when the box temperature has risen to 36°F.

It is important to note that Beacon II has a minimum 2 minute “ON” time and a minimum 4 minute “OFF” time. This means that the system will run in the cooling mode a minimum of 2 minutes even if the setpoint temperature is met. In applications where the system is grossly oversized, the box temperature could go below the differential temperature before the system cycles off.

In the “OFF” cycle the system will be off for a minimum of 4 minutes even if the box temperature goes above the differential temperature, before cooling will be restarted.

- The on board **room thermostat** is factory set at 35°F for Air Defrost systems and -10°F for electric defrost system.

LEAK TESTING

After all lines are connected, the entire system must be leak tested. The complete system should be pressurized to not more than 150 psig with refrigerant and dry nitrogen. The use of an electronic type leak detector is highly recommended because of its greater sensitivity to small leaks. As a further check it is recommended that this pressure be held for a minimum of 12 hours and then rechecked. For a satisfactory installation, the system must be leak tight.

REFRIGERANT CHARGING

Beacon II systems are shipped standard with a head master valve (Scroll compressor models has a 100 Psi head master valve. All other models have a 180 Psi head master valve.) The maximum system refrigerant capacity is the receiver capacity as listed in the sales literature plus the liquid line capacity. Do not add more refrigerant to the system than 90% of the receiver capacity.

Start-Up Operation

SINGLE SYSTEM with 1 EVAPORATOR

- Check all wiring connections to be sure they are correct and tight.
- On condensing unit
 - Check the setting of Time Delay relay. It should be set at 1 minute (the second marker).
 - Check the Low Pressure switch setting on freezer units. It must be set to 0 PSIG cutout, 10 PSIG cut-in to allow positive start and operation, especially in cold ambients. This can be changed to a higher value in warmer climates. On cooler units, the Low Pressure switch has a fixed setting and cannot be adjusted.
- Turn power on
- On the evaporator
 - Use the “PROGRAM REVIEW” button to scroll through settings.
 - Check “**rEF**” (Refrigerant Type). Factory defaults are: Air Defrost R-22, Electric Defrost R-404A. Change to the refrigerant being used.
 - Check “**bot**” (Box Temperature). Factory defaults are: air defrost 35°F and electric defrost -10°F. Change to the desired temperature.
 - Review and change other setting if necessary
 - See procedures below on how to change settings.

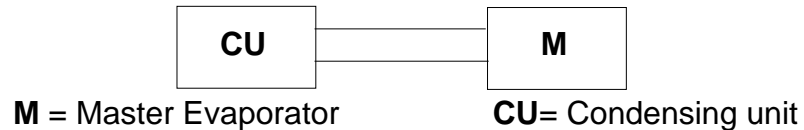

SINGLE SYSTEM with MULTIPLE EVAPORATORS

- Check all wiring connections to be sure they are correct and tight.
- On Condensing unit
 - Check the setting of Time Delay relay. It should be set at 1 minute (the second marker).
 - Check the Low Pressure switch setting on freezer units. It must be set to 0 PSIG cutout, 10 PSIG cut-in to allow positive start and operation, especially in cold ambient. This can be changed to a higher value in warmer climates. On cooler units, the Low Pressure switch has a fixed setting and cannot be adjusted.
- Turn power on.
- On **MASTER** evaporator
 - DO NOT REMOVE the Room Sensor from any evaporator
 - Use the “PROGRAM REVIEW” button to scroll through settings.
 - Check “*rEF*” (Refrigerant Type). Factory defaults are: air defrost R-22, electric defrost R-404A. Change to the refrigerant being used.
 - Check “*bot*” (Box Temperature). Factory defaults are: air defrost 35°F and electric defrost -10°F. Change to the desired temperature.
 - Review and change other setting if necessary.
 - See procedures below on how to change settings.
- On **SLAVE** evaporators. All Beacon II boards are shipped with the factory default as a “MASTER” evaporator.
 - DO NOT REMOVE the Room Sensor from any evaporator
 - Each SLAVE Evaporator must be changed to identify it as a SLAVE. Use the “PROGRAM REVIEW” button to scroll until “*SLA*” appears, then use the “SELECT” knob to select “**YES**” then press “**ENTER**”.

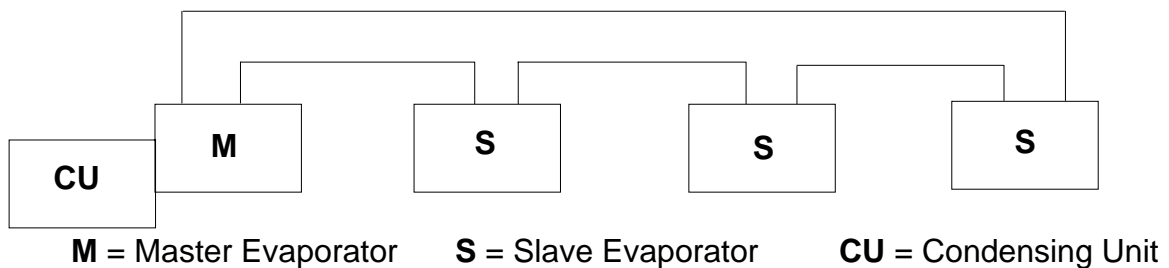

MULTIPLE SYSTEMS with MULTIPLE EVAPORATORS

(Requires a Smart Controller)

- Check all wiring connections to be sure they are correct and tight.
- On condensing units
 - Check setting of Time Delay relay. It should be set at 1 minute (the second marker).
 - Check the Low Pressure Switch setting on freezer units. It must be set to 0 PSIG cutout, 10 PSIG cut-in to allow positive start and operation, especially in cold ambient. This can be changed to a higher value in warmer climates. On cooler units, the Low Pressure switch has a fixed setting and cannot be adjusted.
- Turn power on.
- On MASTER Evaporator
 - DO NOT REMOVE the Room Sensor from any evaporator
- On SLAVE evaporators. All Beacon II boards are shipped with the factory default as a "MASTER" evaporator.
 - Each SLAVE evaporator must be changed to identify it as a SLAVE. Use the "PROGRAM REVIEW" button to scroll until "**SLA**" appears, then use the "SELECT" knob to select "**YES**" then press "**ENTER**".
- Use the Beacon II Smart Controller to set system parameters. See Beacon II Smart Controller installation instructions for more details.

MULTIPLE SYSTEM CONNECTION

(See Smart Controller instruction manual for more details.)

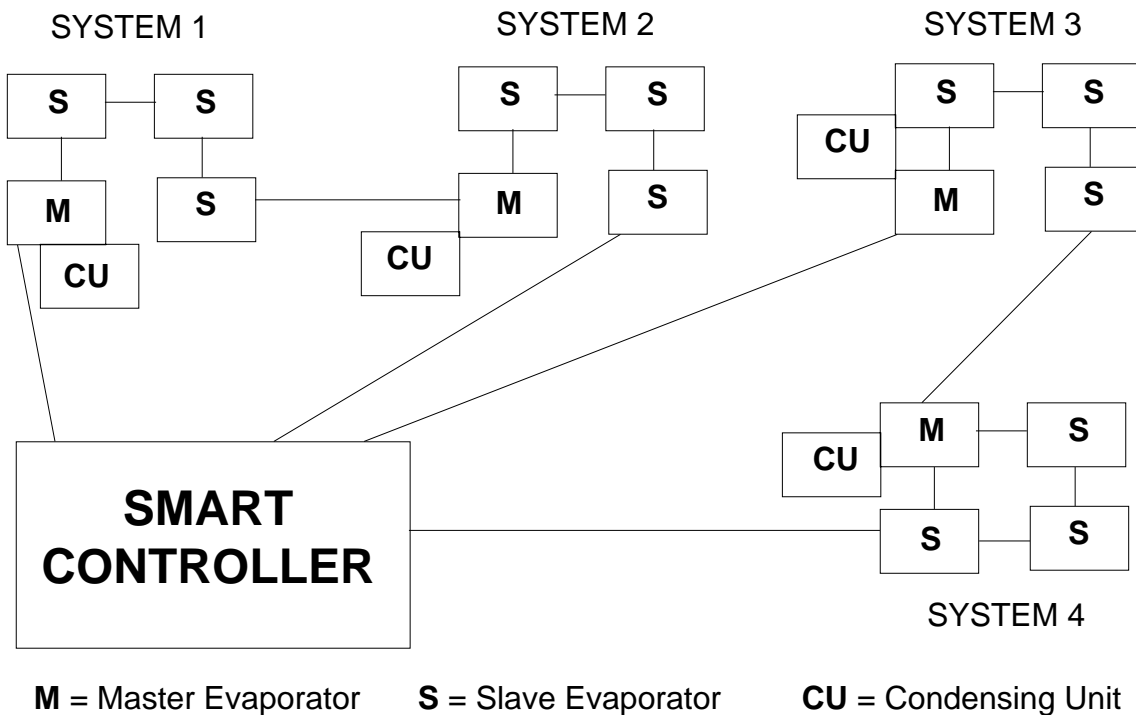

INITIAL POWER ON

At the initial application of power to the system, the compressor and the evaporator fans will be in a 4 minute hold-off cycle and will not start immediately. When there is a call for COOLING, the expansion valve (EEV) opens, then the compressor is started. The compressor will then run for a minimum of 2 minutes in the “hold-on” cycle. (This means that the compressor will run for a minimum of 2 minutes before shutting off even if the box temperature is met.)

The LED alternately displays *BOX TEMPERATURE* and *MODE* of operation. On a call for cooling, *dLY* will show while the expansion valve is opening. After the compressor starts the LED will alternately display *BOX TEMPERATURE* and *Coo*.

On multiple evaporator systems the MASTER evaporator will display *BOX TEMPERATURE* and *Coo*. The SLAVE evaporators will display *Coo* only.

When the room thermostat setting is satisfied, and if the compressor ran for at least 2 minutes, the EEV will close and the compressor will pumpdown and shut off. The evaporator fans will continue to run. The LED will alternately display *oFF* and *BOX TEMPERATURE*.

When the room sensor detects a rise in temperature of approximately 2°F, and the compressor has been off for at least 4 minutes, the EEV will open to its last position then the compressor will start. The valve is then adjusted as necessary to obtain the setpoint superheat setting. During this time, the compressor will run for a minimum 2 minutes “hold-on” cycle.

The four minute “Hold-off” can be bypassed and the system started immediately by pressing the “Reset” button on the Beacon II board.

OPERATING MODE DISPLAY

- oFF*** - Off
- Coo*** - Cooling
- Pdn*** - Pumpdown
- dEF*** - Defrost
- drn*** - Draining
- dLY*** - Delay
- tSt*** - Test
- SER*** - Service



PROGRAMMING AND REVIEWING SETTINGS/CHANGES

The **Program Review** button is used to program, review and change all program settings for the system.

Press “**PROGRAM REVIEW**” button. The Setpoint item will appear on the LED. After a few seconds delay the Setpoint value will display. Each time the button is pressed a different setpoint item is displayed.



Next, use the “**SELECT**” knob to change value of Setpoint Item.

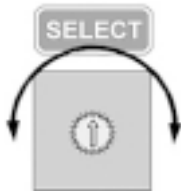

Next, When the desired value is selected, press the “**ENTER**” button to place it in program memory. If the “**ENTER**” button is not pressed the value will not be stored in the memory and thus will not be changed.



“PROGRAM REVIEW” ITEMS

- A-E** - Set Defrost type (*Air* or *ELE*)
- rEF** - Set Refrigerant type (R22, R404A or R507)
- bot** - Set Box temperature (-30°F to +70°F)
- SUP** - Set Superheat (4°F to 20°F)
- SLA** - Set Board as a Slave (Yes or No)
- dFn** - Set Number of defrosts per day (1,2,3,4,5,6,8,10 or 12 per day)
- dFF** - Set Defrost Fail-safe time (10 to 200 minutes)
- dFt** - Set Defrost End temperature (40°F to 100°F)
- dFS** - Set Defrost Delay Start Time (0.5 Hours to 23.5 Hours)
- ALH** - Set Alarm High temperature (-40°F to 90°F)
- ALL** - Set Alarm Low temperature (-40°F to 90°F)
- Alt** - Set Alarm time (2 to 120 minutes)
- F-C** - Set Fahrenheit/Celsius temperature units (°F/°C)

PROGRAMMING AND REVIEWING SETTINGS/CHANGES (cont'd.)

Use the “PROGRAM REVIEW” button to select these items:



- Defrost Type – “**A-E**” - Selection is made for air defrost or electric defrost coil. This will automatically set the system factory defaults for air defrost and electric defrost. (See default settings.) Please note that the refrigerant type *default* for air defrost is R-22 and for electric defrost it is R404A. All units are shipped with factory defaults settings.
- Refrigerant Type - “**rEF**” - Selection for type of refrigerant – R-22, R-404A or R-507. *Default: Air defrost is R-22 and for electric defrost it is R-404A.*
- Box Temperature - “**bot**” - Select box temperature setpoint. Selection range is -30 °F to +70 °F. *Defaults: Electric defrost -10°F and air defrost +35°F.*
- Superheat - “**SUP**” - Evaporator superheat is controlled by the board on each evaporator. Each board measure the evaporator saturation suction temperature and the suction pressure to determine the superheat. The superheat value at the evaporator can be changed to ensure a 20 °F to 30 °F superheat at the Compressor. *Default: 8°F.*
- Evaporator Board: Slave? - “**SLA**” - On multiple evaporator systems, each evaporator board has to be programmed to be a Master or a Slave. Each board is shipped from our factory set as a Master. You must make this change to each Slave evaporator. A selection of “YES” is made for this setting.

The default for each board is a Master, so on Single Evaporator systems no change is required.

- No. of Defrost per Day - “**dFn**” - A selection must be made for the number of defrosts cycles per day – 1,2,3,4,5,6,8,10 or 12 per day. If no selection is made, *Defaults: electric defrost 4 per day and air defrost 2 per day.*
- Defrost fail-safe - “**dFF**” - This is the maximum time allowed for a coil to remain in defrost. Defrost will be terminated if the defrost end temperature is not attained when this time has expired. On multiple evaporator systems this is controlled by the Master unit. Each board should have the same setting. *Defaults: electric defrost 30 minutes and air defrost 40 minutes.*
- Defrost End Temperature - “**dFt**” - This is the temperature at which the Defrost will be terminated. *Defaults: electric defrost +60°F and air Defrost +45°F.*
- Defrost Delay Start Time - “**dFS**” - This allows the delay of the start of the first defrost. *Defaults: 0.5 hours to 23.5 hours.*

PROGRAMMING AND REVIEWING SETTINGS/CHANGES (cont'd.)

- Alarm High Temperature - "**ALH**" - Temperature at which a high box temperature alarm will be triggered. This does not apply during defrost. *Defaults: electric defrost +5°F and air defrost +50°F.*
- Alarm Low Temperature - "**ALL**" - Temperature at which a Low Box Temperature alarm will be triggered. *Defaults: Electric Defrost -15°F and Air Defrost +30°F.*
- Alarm Time - "**ALt**" - Time which High Temperature or Low Temperature condition must exceed before alarm is triggered. *Default: 60 minutes.*
- °F/°C - "**F-C**" - Select units to display temperature. Fahrenheit or Celsius. *Default: Fahrenheit.*
- When °C is selected a red dot will appear in the right bottom corner of the LED display of the Beacon II board.

Use the "**MONITOR**" button to review these items:

- SUP** - Superheat (°F/°C)
- ESP** - Expansion valve steps (0 to 255 steps)
- Sct** - Suction temperature (°F/°C)
- SSt** - Saturated Suction temperature (°F/°C)
- SCP** - Suction pressure at Evaporator (PSIG/HG)
- Odt** - Outdoor temperature (°F/°C)
- dFt** - Defrost sensor temperature (°F/°C)
- dFS** - Time left until next defrost (hours) (on version 1.8 boards)
- dFE** - Last Defrost Elapsed time (minutes)
- AC** - Board Voltage
- Spt** - Spare Temperature reading



Use this button to "**FORCE DEFROST**"

To force a defrost, press the "**FORCE DEFROST**" button. The system will pumpdown and shut off the compressor. The heaters are then turned on. The display will show "**dEF**" and room temp.

Use this button to "**RESET TIME**"

Pressing this button will reset the time clock in the microprocessor to zero. At initial power up, pressing this button will bypass the "four minute" hold-off and the system will start immediately after the expansion valve opens. This display will show "**dLy**".



Use this button to "**FORCE SERVICE**"

Pressing this button TWICE will cause the system to pumpdown and the compressor to shut off. The system will remain off until the "CLEAR" button is pressed. While in the "FORCE SERVICE", the LED display will only show "**SEr**".

PROGRAMMING AND REVIEWING SETTINGS/CHANGES (cont'd.)

Use this button to “**CLEAR/TEST**”

Pressing this button ONCE will return the LED display to the default display. With the system in the **OFF** mode, pressing and holding this button will start the “**TEST**” mode. In the “**TEST**” mode it will cycle through each output for 10 seconds. The display will only show “tst” during “**TEST**” mode. Test mode will automatically terminate after 3 sequences.



LOCKING THE BEACON II BOARD

The Beacon II board is lockable to prevent programmed setting changes by unauthorized personnel. When locked, the program setpoints cannot be changed.

To **lock** the setting:

- Press “PROGRAM REVIEW” button.
- Press and **hold** “MONITOR” button.
- **While holding** “MONITOR” button, press “ENTER” button.
- The LCD will display **Loc**.

This will prevent unauthorized personnel program changes. To **unlock**, repeat steps above. LCD will display “**UnL**”.

STATUS INDICATOR LED

A RED, three-digit , alphanumeric LED on the Beacon II board indicates status, alarms and error codes.



	<u>LED Display</u>	
<ul style="list-style-type: none"> • OFF All Evaporators 	<i>Box Temp / OFF</i>	Box Temperature/ Mode is displayed
<ul style="list-style-type: none"> • COOLING <i>Single Evaporator -</i> <i>Multiple Evaporators</i> Master Evap - Slave Evaps - 	<i>Box Temp / COO</i> <i>Box Temp / COO</i> <i>COO</i>	Box Temperature/ Mode is displayed Box Temperature/ Mode is displayed Operating Mode is displayed
<ul style="list-style-type: none"> • Pumpdown All Evaporators 	<i>Pdn</i>	
<ul style="list-style-type: none"> • DEFROST All Evaporators 	<i>dEF</i>	
<ul style="list-style-type: none"> • TEST All Evaporators 	<i>tSt</i>	
<ul style="list-style-type: none"> • SERVICE All Evaporators 	<i>SER</i>	
<ul style="list-style-type: none"> • ALARMS 	<i>A 1</i> <i>A 2</i> <i>A 3</i> <i>A 4</i>	High Box Temp Low Box temp System Start-up failure Compressor pumps down and tries to restart after 4 minutes. Input Fault Box Temp., Suction Temp., Pressure Transducer open or not installed

STATUS INDICATOR LED

• ERRORS

- E 1** - Room temperature sensor shorted, open or not installed
- E 2** - Defrost temperature sensor shorted, open or not installed
- E 3** - Suction temperature sensor shorted, open or not installed
- E 4** - Suction pressure transducer shorted, open or not installed
- E 5** - Outdoor temperature sensor shorted
- E 6** - Low superheat during cooling
- E 7** - Compressor shutdown (high or low refrigerant pressure or low oil pressure)
- E 9** - Multi-in/Multi-out wiring error

• OTHERS

- Coo** - Room Temperature sensor open or not connected (Instead of displaying box temperature)
- Loc** - Board is locked. Settings cannot be changed
- UnL** - Unlock the board settings

LOW AMBIENT OPERATION

All units are shipped standard with Head Master valves. (Scroll compressor units have a 100 Psi Head Master valve and all other systems have a 180 Psi head master valve.) Condensing units with **multiple condenser fans** will have one or more fans cycle on Pressure Fan Cycling switch.

An adjustable Time Delay relay, factory set at 1 minute, is wired across the Low Pressure switch (LPS). In cold ambient this allows time for the suction pressure to build up and prevent nuisance tripping of the LPS.

Pumpdown

At the end of each cooling cycle, when the box temperature is met, the Beacon system will pump down and shut off the compressor.

To pumpdown, the EEV closes and the compressor runs until one of the following occurs:

- the Low Pressure Switch opens
- the suction pressure at the evaporator is 4 psig
- a total of two minutes has elapsed.

When any of these three conditions occurs the compressor will turn off and not restart until there is a call for cooling or a periodic pumpdown.

Periodic pumpdown

While in the OFF cycle, if there isn't a call for cooling (Box setpoint temperature is met) but:

- the evaporator suction pressure has risen to 10 psig
- the low pressure switch has closed

The system will initiate pumpdown. This periodic pumpdown will occur at 4 minute intervals when these two conditions are met.

Service Mode

A single pole, single throw switch (SPST) is supplied in each condensing unit for shutting off the system. Closing the “Service” switch in the condensing unit will cause the system to pumpdown and shut off. “Ser” will be displayed on the Beacon board LED and “SERVIC” is displayed on the Smart Controller LCD display. The Evaporator Fan and Heaters will be de-energized in the Service Mode. **The system will not restart until the SPST switch is placed in the “NORMAL” or “OFF” position.**

or

A remote “Service” switch can be added to the Beacon II board across the “Ser” and “C” connections of the terminal block. It will operate in the same manner as the switch above.

or

The system can be pumped down by pressing the “**SERVICE**” button twice. To restart the system, press the “**CLEAR**” button.

or

The system can be pumpdown for service by closing the Liquid line service valve in the condensing unit, then closing the suction line service valve when the system trips on the low pressure switch.

In order for air defrost evaporator fan motors to cycle off during “Service” mode, the fan motors must be wired through the fan relay on the Beacon II board.

Defrost

DEFROST TIMING

When power is first applied to the system, its timer starts counting time. If 4 defrost are programmed, it will initiate a defrost every 6 hours from when power was first applied. Beacon II does not have a real time clock. Beacon II does provide the ability to delay the starting of the first defrost.

DEFROST DELAY START TIME

Example: The system is first powered up at 8:00 AM and is programmed for 4 defrost per day. The user would like the first defrost at 10:00 AM. To accomplish this, use the “**PROGRAM REVIEW**” button to scroll to **dFS**. Use the “**SELECTOR**” switch to select 2 hours delay start, then press “**ENTER**”. The 1st defrost will now occur at 10:00 AM and then a defrost will occur every 6 hours thereafter.

TIME REMAINING UNTIL NEXT DEFROST (on version 1.8 boards)

To find out how much time is left until the next defrost is scheduled, use the “**MONITOR**” button to scroll to **dFS**. The time displayed will be how much time until the next scheduled defrost.

DEFROST SCHEDULE IN MEMORY

Beacon II does not have a real time clock but it keeps track of the time that has elapsed in its memory. It also keeps in memory the number of defrosts scheduled and how much time has elapsed between defrosts. If a power failure occurs, when power is restored Beacon II remembers how many defrosts are scheduled and it remembers how much time was left until the next defrost. It will then defrost based on this timing. So, if the power failure lasted 15 minutes, the defrost schedule will be off by 15 minutes.

RESETTING DEFROST SCHEDULE

When a power interruption causes a severe lag in the defrost schedule, the defrost schedule can be reset in the following manner. First, press the reset time button on the board to zero out the internal counters. Then, program the appropriate defrost delay start time for the next desired defrost period. The defrost schedule will be correct until you have another power outage.

ELECTRIC DEFROST MODE

When a defrost is initiated, the EEV closes, the compressor is allowed to pumpdown and shut off. The evaporator fans are cycled off and the defrost heaters are energized.

On multiple evaporator systems, all controllers must terminate their defrost, either on temperature or fail-safe time, before the master controller will end the defrost cycle. There is a 2 minute condensate drain-down period after which the compressor is started for a refreeze period. The evaporator fan stays off (fan delay). The refreeze period will last until the evaporator suction temperature is at 28°F or 3 minutes has elapsed. After this sequence, the system is back in the refrigerating mode and evaporators fans are now running.

AIR DEFROST MODE

The sequence is the same as for electric defrost except that there are no heaters and the evaporator fans run continuously. If the air defrost for motors are wired through the fan relay on the board, they will remain energized during defrost mode.

ALARMS

Beacon provides a set of dry contacts for use in signaling an alarm. These contacts can be connected to a light, a buzzer, a bell etc., which will be activated when an alarm condition occurs. When the Beacon II is energized, the alarm contacts are OPENED. When an alarm condition is detected, the contacts are CLOSED.

Conditions under which the alarm contacts will close are:

- High Box Temperature – LED Display: **A 1** - Room temperature has exceeded the Alarm High **ALH** value for the Alarm time **ALt**, programmed.
- Low Box Temperature - LED Display: **A 2** - Room temperature has dropped below the Alarm Low **ALL** value for the Alarm time **ALt**, programmed
- System Start-up failure – LED Display: **A 3** - Compressor pumps down and tries to restart after 4 minutes. After 4 unsuccessful attempts to restart, the alarm code **A 3** is displayed. System continues trying to restart.
- Input Fault – LED Display: **A 4** - Box Temp., Suction Temp., Pressure Transducer open or not installed.
- Power failure – Loss of power to the Evaporator

ALARM CODES

A 1	High Box Temp	
A 2	Low Box temp	
A 3	System Start-up failure	Compressor pumps down and tries to restart after 4 minutes
A 4	Input Fault	Box Temp., Suction Temp., Pressure Transducer open or not installed

CLEARING ALARMS

Alarms A1 – High Box Temp. and A2 – Low Box Temp. will clear automatically if the Box Temp. decreases or increases to below or above the Alarm setpoint temperature. Placing the system in the “**Service Mode**” or turning off power will clear the A3 Alarm. Replacing the Room Sensor, Suction Sensor or Pressure Transducer will clear the A4 Alarm.

ERROR INDICATOR LED



At initial power up, each Beacon board checks for system errors. The system error check involves checking the various temperature sensors to determine whether any of these sensors are shorted or open.

The system will pumpdown and cycle off and **will not restart** until the fault is cleared or the circuit breaker reset, for the following conditions:

- Suction sensor shorted, open or not installed
- Room temperature sensor shorted or not installed
- Pressure Transducer open or not installed

The system will pumpdown, cycle off and **try to restart for these faults**. Each try will be after the 4 minutes “Hold Off” period, for the following fault conditions:

- High pressure or low pressure cutout
- Oil pressure

After the fourth try, the Alarm contacts will be closed and an alarm message displayed on the LED. To clear this condition, the system should be cycled through the “**Service Mode**” after the correction is completed.

ERROR CODES

- E1* - Room temperature sensor shorted, open or not installed
- E2* - Defrost temperature sensor shorted, open or not installed
- E3* - Suction temperature sensor shorted, open or not installed
- E4* - Suction pressure transducer shorted, open or not installed
- E5* - Outdoor temperature sensor shorted
- E6* - Low superheat
- E7* - Compressor shut down (high or low pressure switch open or oil pressure switch open)
- E9* - Multi-in/multi-out wiring error

EVAPORATOR FANS SHUT OFF

In some installations, it is desirable to shut off the evaporator fans periodically. This is easily accomplished on Beacon II by wiring a single pole, single throw switch (SPST) between the terminals marked “SERVICE” and “COM” on the Beacon II board. Closing this switch will cause the system to pumpdown and shut off. Air Defrost fan motors must be wired through the fan relay on the Beacon II board for this to be effective on Air Defrost systems. The entire system will be shut off and remain off until the SPST switch is opened.

Air Defrost evaporator fans are setup to run constantly. If there is a need to shut down the evaporator fans on an Air Defrost system, this can be accomplished by wiring the evaporator fan motor or evaporator fan motor contactor through the fan relay on the Beacon II board. When this is done and the Air Defrost system is placed in “SERVICE,” the evaporator fans will shut off when the system is in pumpdown.

CHECKING OPERATION OF EXPANSION VALVE (EEV)

To check if the expansion valve is closing properly:

Install a pressure gauge-set to suction line at the condensing unit. With the system running, close the valve on the liquid line, at the condensing unit. The system should pumpdown and shut off on the Low Pressure switch (LPS). If the system does not pumpdown and trip on the LPS then the compressor valves are weak and needs to be changed.

After the system pumps-down and trip on the LPS, put the system in the service mode. This will cause the Expansion valve to close.

Open the valve on the liquid line, at the condensing unit. The suction pressure reading on the gauge set should not increase. If the suction pressure increases then the expansion valve is leaking and should be changed.

The Expansion valve position can be monitored from the LED display pressing the “**MONITOR**” button and scrolling to **ESP**. This will indicate the number of steps the valve is open.

This can also be checked by using the EXV test pins on the board. This is indicated by a 0 to 5 Volts DC signal. At 0 Volt the valve is closed and at 5 Volts the valve is fully open. At values between 0 and 5 Volt, the valve will be opened proportionately.

Use the “MONITOR” button to display “**SCP**” Evaporator Suction Pressure. Record the pressure displayed. Start the system and observe the pressure displayed. If the pressure does not increase, the expansion valve could be defective.

If the system is running, use the “MONITOR” button to display “**SCP**” Evaporator Suction Pressure. Record the pressure displayed. While the system is running, press the “FORCE SERVICE” button. Observe the pressure while the system is pumping down. The pressure should decrease. If it does not, this indicates a defective valve.

EXPANSION VALVE MOTOR WINDING RESISTANCE

If the expansion valve is suspected of not functioning properly the motor windings resistance should be measured. This is a bipolar motor with two windings. Measure the resistance at the pins, on top of the valve, between locations A and B or C and D. (Note that the pins are not labeled A, B, C, D. This labeling is just for reference. Also, two of the pins, at location B and location D, have a wider spacing between them than between location A and C)

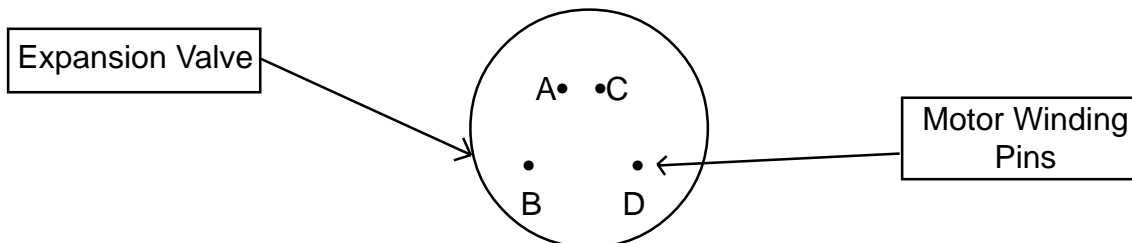

For valve sizes 29320003 and 29320004, the resistance measured between pin locations A and B or C and D should be approximately 336 Ohms when the valve is at 75°F.

For valve sizes 29320007, 29320008, 29320013 and 29320014, the resistance measured between pin locations A and B or C and D should be approximately 116 Ohms when the valve is at 75°F.

Measuring resistance between locations A and C or B and D will always show “Open” because these locations are between the motor windings.

When the valve is opening or closing, the voltage measured between A and B or C and D should be between 20 to 22 VAC.

Measuring the DC volt of the EXV TEST pins, on the board, will also indicate if the expansion valve is open or close. 0 volts DC indicates the valve is closed. 5 volts DC indicates the valve is fully open. A Values between 0 and 5 volts indicates how much the valve is open or close.

POWER FAILURES

In the event of a power failure Beacon II will automatically close the expansion valve to prevent refrigerant from migrating throughout the system. After power returns, with 24 VAC at the board, the system will restart in the cooling mode after the four-minute hold off period.

SPARE SENSOR TERMINALS

Beacon II provides a set of input terminals for customers who may want to monitor an additional temperature or items such as Product Temperature. This input terminal requires a signal from a thermistor which meets the temperature/resistance values in Table 1 on page 22.

If a product temperature simulator is used it must meet the resistance/temperature specification listed in TABLE 1. The temperature range for this input is -30°F to 140°F . Sensors on the Beacon system, as supplied, will not simulate product temperature.

This input can be monitored on the LED display by using the “MONITOR” button and scrolling to **Spt**. The values displayed will be the temperature of the spare sensor.

CHECKING SENSORS

DO NOT REMOVE SENSORS FROM EVAPORATORS FOR CHECKING.

Use the monitor button to display the value the sensors are reading on the LED (suction temp. SCt, defrost temp. dFt or room temp.). Compare this value to the measured value with a thermometer at each of these points. If they do not match, change the sensor.

OR

The sensors can be checked for their proper operation by placing it in a cup of ice water. Stir the ice water and measure the resistance of the sensor. At 32°F the resistance should be 32,650 ohms. If it is higher or lower by 5,000 ohms approximately, the sensor should be replaced.

Table 1. Resistance/Temperature Specification

Temperature °F	Ohms	Temperature °F	Ohms
104	5,320	32	32,650
86	8,060	23	42,330
77	10,000	14	55,330
68	12,490	5	72,950
59	15,710	-4	97,070
50	19,900	-13	130,410
41	25,400	-22	176,960

Table 2. System Defaults

PARAMETERS	CODE	AIR	ELECTRIC
Refrigerant	<i>rEF</i>	R-22	R-404A
Box Temperature	<i>bot</i>	35°F	-10°F
Superheat	<i>SUP</i>	8°F	8°F
Slave Evaporator	<i>SLA</i>	No	No
No. of Defrost per Day	<i>dFn</i>	2	4
Defrost Fail-safe time	<i>dFF</i>	40 min.	30 min.
Defrost End Temperature	<i>dFt</i>	45°F	60°F
Defrost Delay Start Time	<i>dFS</i>	0 hrs.	0 hrs.
Alarm High Temperature	<i>ALH</i>	50°F	5°F
Alarm Low Temperature	<i>ALL</i>	30°F	-15°F
Alarm Time	<i>ALt</i>	60 min.	60 min.
Temperature Units	<i>F-C</i>	°F	°F

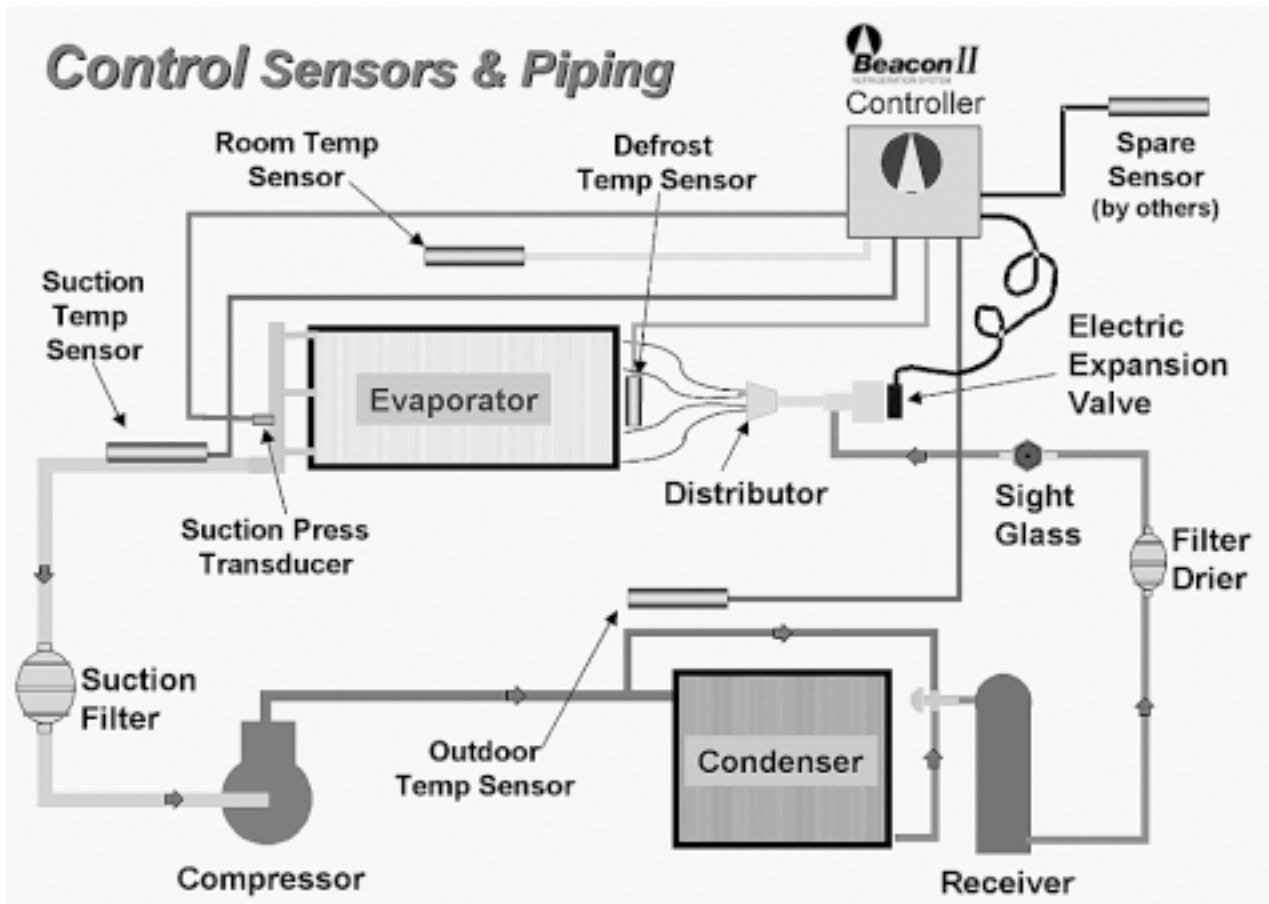

Table 3. Parts List

PART DESCRIPTION	HRPD PART NUMBER
Beacon II Control Board	28910101
*Temperature Sensor kit – White Leads	89904902
Transformers:	
120/24 volt– 40 VA	22529601
240/24 volt - 40 VA	22529602
460/24 volt – 40 VA	22529603
575/24 volt – 40 VA	22529701
Pilot Relay	22511401
Contactora for Compressor 40 amp with 24 volt Coil	2252440
Terminal Block – Condensing Unit	2251266
Low Pressure Switch Time Delay Relay	22536801
Electric Expansion Valve	
ESB 1 – 3/8" x 3/8" Conn	29320003
ESB 4 – 3/8" x 3/8" Conn	29320004
ESB 10 – 3/8" x 3/8" Conn	29320007
ESB 10 – 1/2" x 1/2" Conn	29320008
ESB 15 – 7/8" x 1 3/8" Conn	29320013
ESB 20 – 7/8" x 1 3/8" Conn	29320014
Expansion Valve Molded Connector	
(Bipolar valves)	22515201
(Unipolar valves)	22515202
Pressure Transducer	28911201
Pressure Transducer Harness	22515101
Beacon II Smart Controller	89704301
**Smart Controller Software Package	89704101
Beacon II Communications Hub	89708001

*Only the sensor with white leads is shipped as a Service replacement part.

**Smart Controller Software package is sold separately

Table 4. Operational Limits

OPERATIONAL LIMITS	
Voltage Range	18 VAC to 30 VAC
Controlling Box Temp. Range	-30°F to 70°F
Temperature Differential	2°F
Cold Ambient Limits	Start & operate to -20°F



Expansion Valve Capacity

Part Number	Valve	R-22				R-404A / R-507			
		Evaporator Temperature (°F.)				Evaporator Temperature (°F.)			
		+20		-20		+20		-20	
		Pressure Drop Across Valve (psi)				Pressure Drop Across Valve (psi)			
		100	BTUH	100	BTUH	100	BTUH	100	BTUH
29320003	ESVB-1	0.68	8160	0.64	7680	0.48	5760	0.42	5040
29320004	ESVB-4	3.27	39240	3.07	36840	2.31	27720	2.05	24600
29320007 - 08	ESVB-10	8.02	96240	7.54	90480	5.65	67800	5.01	60120
29320013	ESVB-15	15.14	181680	14.25	171000	10.69	128280	9.47	113640
29320014	ESVB-20	22.18	266160	20.87	250440	15.65	187800	13.86	166320

Diagnostics

Beacon II Troubleshooting Guide

PROBLEM	Step	ACTION ITEM	IF OK	IF NOT OK
LED is not lit.	1.	Check Primary Power Supply Disconnect	Go to next step	1. Check fuses and circuit breakers
	2.	Check Voltage to Evaporator Transformer		2. Check field wiring for breaks
	3.	Check Transformer Secondary Output Volts		3. Replace if necessary
	4.	Check Voltage at Control Board (24V and C)		4. Check factory wiring and connections
	5.	Replace Control Board		
LED shows Coa , but compressor will not run.	1.	Check Compressor internal overloads	Go to next step	1. Wait for reset
	2.	Check Control Power to Condensing Unit (24 Volts across "COMP" and "C" at board)		2. Check transformer voltage (secondary and primary) and wiring of 208V power taps.
	3.	Check Compressor Contactor Coil Voltage		3. Check internal condensing unit wiring
	4.	Check Compressor Contactor "pulled in"		4. Replace as needed
ERROR CODES:				
<i>E1</i> Room Sensor		Check Sensor and Board Connection		Replace as needed
<i>E2</i> Defrost Sensor		Check Sensor and Board Connection		Replace as needed
<i>E3</i> Suction Sensor		Check Sensor and Board Connection		Replace as needed
<i>E4</i> Suction Transducer		Check Transducer and Board Connection		Replace as needed
<i>E5</i> Outdoor Sensor		Check Sensor, wiring and Board Connection		Replace or remove
E6 Low Superheat During Cooling (0°F for 2 minutes)	1.	Check Refrigerant Type	Go to next step	1. Compare board setpoint and refrigerant
	2.	Check coil for ice		2. Defrost coil and check defrost cycle settings/setpoints, defrost sensor and heater amps.
	3.	Check Control Board step position from board LED		3. Replace board if EEV steps not at 2.
	4.	Check Electric Expansion Valve Closure		4. Pumpdown system see if LPS opens or if it times out (EEV is bad or LPS is set incorrectly, if times out) – See Pumpdown.
	5.	Compressor Not Operating		5. Check overloads and contactor.
	6.	Check Suction Temperature Sensor		6. Compare board sensor reading against actual suction line temperature.
	7.	Check Suction Pressure Transducer		7. Compare pressure reading against gauges.

Beacon II Troubleshooting Guide (continued)

PROBLEM	Step	ACTION ITEM	IF OK	IF NOT OK
E7 Compressor Shutdown	1.	Check wiring connection to the board		<ul style="list-style-type: none"> • Correct field wiring to the board
	2.	Low Pressure Safety (LPS) Tripped: <ul style="list-style-type: none"> • Check for correct refrigerant type • Check refrigerant charge • Check LPS setting • Check LPS wiring • Check EEV operation (stuck?) • Check coil for icing • Check for correct superheat reading • Check for correct nozzle selection • Check for clogged EEV inlet screen • Check line sizing • Check LPS time delay relay setting • Check operation of LPS 		<ul style="list-style-type: none"> • Change setpoint to match refrigerant • Add more refrigerant to proper charge • Correct LPS setting • Correct LSP wiring • Clean or replace EEV • Defrost coil (see E6, step 2) • Check/replace sensor or transducer • Replace distributor nozzle • Replace EEV • Correct line sizing • Reset to 1 minute • Replace Low Pressure Safety Switch
	3.	High Pressure Safety (HPS) Tripped: <ul style="list-style-type: none"> • Check for system overcharge • Check for non-condensables • Check condenser fan motor and blade • Check for dirty condenser coil • Check head pressure controls • Check fan cycling controls • Check liquid line sizing • Check for liquid line restrictions • Check operation of HPS 		<ul style="list-style-type: none"> • Reclaim/recover excess charge • Remove all non-condensables • Repair or replace motor and/or blade • Clean condenser coil • Adjust or replace faulty controls • Adjust or replace faulty controls • Correct line sizing • Repair line or remove restrictions • Replace HPS if necessary
	4.	Oil Pressure Safety (OPS) Tripped: <ul style="list-style-type: none"> • Check oil level in compressor • Check oil sump screen pickup • Check oil pump pressure • Check for proper piping practices • Check for low superheat (see E6) • Check operation of auxiliary relay (R6) • Check OPS sensor • Check operation of OPS 	Go to next step	<ul style="list-style-type: none"> • Add oil to crankcase to minimum level • Clean or replace pickup screen • Replace compressor oil pump • Correct piping to minimize oil logging • Correct per steps in E6 • Replace auxiliary relay • Replace faulty OPS sensor • Replace faulty OPS
	5.	Compressor Module Tripped (when supplied): <ul style="list-style-type: none"> • Check module • Check superheat at compressor inlet • Check compressor for overheating • Check suction pressure (too low?) 		<ul style="list-style-type: none"> • Replace faulty module • Reduce superheat (TXV adjust, etc.) • Correct overheating problem • Consider crankcase pressure regulator or other measures
	6.	Phase Loss Monitor (PLM) Tripped: <ul style="list-style-type: none"> • Check presence of all phase legs • Check power supply • Check operation of PLM 		<ul style="list-style-type: none"> • Correct power phase problem • Correct power supply problems • Replace faulty PLM
	7.	Demand Cooling (when supplied): <ul style="list-style-type: none"> • Check auxiliary relay • Check demand cooling device 		<ul style="list-style-type: none"> • Replace auxiliary relay • Replace faulty demand cooling device
	8.	Check compressor relay on board		<ul style="list-style-type: none"> • Replace board if relay is faulty

Beacon II Troubleshooting Guide (continued)

PROBLEM	Step	ACTION ITEM	IF OK	IF NOT OK
E9 Multi-out to Multi-in Communication Wiring (only shows after initial successful connection)	1.	Check for 24 volts power to the board		1. If no voltage, see "LED is not lit" above for low voltage, see "88888 LED display"
	2.	Check for crossed communication wiring (multi-out not wired to multi-in terminals)	Go to next step	2. Correct wiring from "Master" unit Multi-out to Multi-in of "Slave" unit, etc. to all Slaves and return to Master. (See wiring diagrams)
	3.	Check for broken communication wiring		3. Correct wiring between first Slave with error to previous board in the sequence.

(E9 continued)
Communication Error Occurrence:

Break in the designated lines will cause errors as follows:

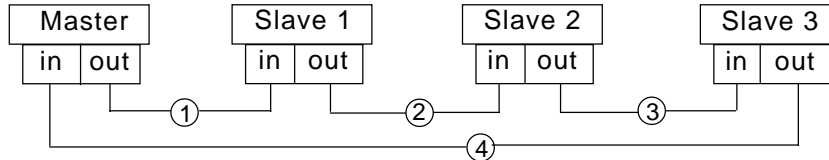

Line #	Master	Slave1	Slave 2	Slave 3
①	E9	E9	E9	E9
②	E9	no error	E9	E9
③	E9	no error	no error	E9
④	E9	no error	no error	no error

[With Beacon II Smart Controller]

Line #	SMART	Master	Slave1	Slave 2	Slave 3
①	+COMM+	E9	no error	no error	no error
②	+COMM+	no error	E9	E9	E9
③	+COMM+	no error	no error	E9	E9
④	+COMM+	no error	no error	no error	E9
⑤	+COMM+	no error	no error	no error	no error

PROBLEM	Step	ACTION ITEM	IF OK	IF NOT OK
888 LED display (power is below 18V and appears at initial power)	1.	Check Voltage to Evaporator Transformer		1. Check field wiring for breaks or shorts
	2.	Check Transformer Secondary Output Volts	Go to next step	2. Replace if necessary
	3.	Check Voltage at Control Board (24 and C)		3. Check factory wiring and connections
	4.	Check Voltage at Beacon II Smart Controller		4. Check field wiring from board

LED displays dLy then oFF with no displayed errors	1.	Check for low voltage		1. Check all steps for "888 LED display" Voltage could drop off too fast to show.
	2.	Check for short in field wiring from "comp" on board to condensing unit terminal connection	Go to next step.	2. Check internal factory wiring to compressor contactor.
	3.	Replace defective contactor (holding coil)		

Beacon II Troubleshooting Guide (continued)

PROBLEM	Step	ACTION ITEM	IF OK	IF NOT OK
Cannot get to box temperature	1.	Check system operation: Is it running?		1. Check power to condensing unit Check position of Service Mode switches Check compressor overloads and contactor
	2.	Check system charge		2. Add or remove refrigerant to proper charge
	3.	Check for proper operating superheat		3. Check EEV operation Check control board EEV signal Check suction sensor and transducer
	4.	Check for high superheat and EEV wide open		4. Check EEV inlet screen and restrictions Check liquid line sizing Check head pressure controls
	5.	Check Low Pressure Safety Switch		5. Check everything for E7 LPS above
	6.	Compare equipment capacity with requirements	Go to next step	6. Add or replace with more/larger equipment
	7.	Check box temperature setpoint		7. Correct setpoint to proper value
	8.	Check compressor performance		8. Check compressor application limitations Check integrity of compressor operation (impaired, worn or damaged components)
	9.	Check condenser coil for dirt/debris		9. Clean condenser coil
	10.	Check condenser for non-condensables		10. Remove all non-condensables
	11.	Check condenser fan operation		11. Replace/repair fan blade, motor, cycling switch or make corrective adjustments.
	12.	Check for correct refrigerant type		12. Compare board setpoint and refrigerant
	13.	Check for iced evaporator coil		13. Defrost coil and check defrost cycle (see E2) settings/setpoints and defrost sensor
	14.	Check defrost parameters		14. Correct defrost setpoints in program (frequency and termination of defrosts)
	15.	Check superheat setpoint (too high?)		15. Correct setpoint for more cooling surface
	16.	Check display values (°F or °C)		16. Correct setpoint for proper display values

Service Mode (SEr is displayed)	<u>Placing system into SERVICE MODE</u> (BOARDS ONLY)		<u>Terminating SERVICE MODE</u> (BOARDS ONLY)	
	1.	Use Remote Service Switch in condensing unit	1.	Must terminate using same switch
	2.	Pressing "Force Service" button board* twice	2.	Press "Clear" button on board
	3.	Connection between "Ser" and "C" on board* (all are wired in parallel; all will activate mode) *ONLY Master board on multiple evaporator systems	3.	Open connection between "Ser" and "C" (Note: If multiple switches were placed in Service Mode, <u>all</u> must be "open" to terminate the mode.)
	<u>(with Beacon II Smart Controller)</u>		<u>(with Beacon II Smart Controller)</u>	
	1.	Use Remote Service Switch in condensing unit	1.	Must terminate using same switch
	2.	Connection between "Ser" and "C" on board*	2.	Open connection between "Ser" and "C"
	3.	From program menu of Beacon II Smart Controller, Change SERVICE setpoint to "On". [all are wired in parallel; any/all will activate mode.] *ONLY Master board on multiple evaporator systems	3.	From program menu of Beacon II Smart Controller, Change SERVICE setpoint to "Off" [Note: If multiple switches were placed in Service Mode, <u>all</u> must be "open" to terminate the mode.]

24 VOLT CONNECTION WIRING - BEACON II

(CONDENSING UNIT WITH ONE EVAPORATOR)

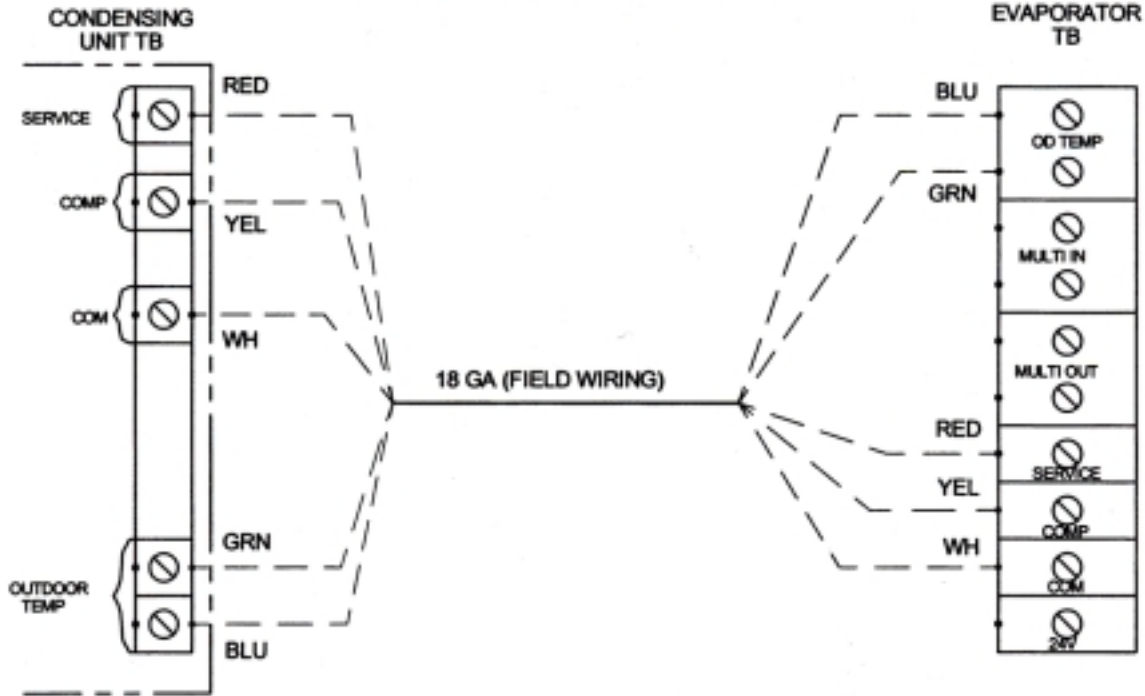

HEATCRAFT PART NO. 29661301
REV B

24 VOLT CONNECTION WIRING - BEACON II

MASTER WITH ONE SLAVE CONNECTION
(CONDENSING UNIT WITH TWO EVAPORATORS)

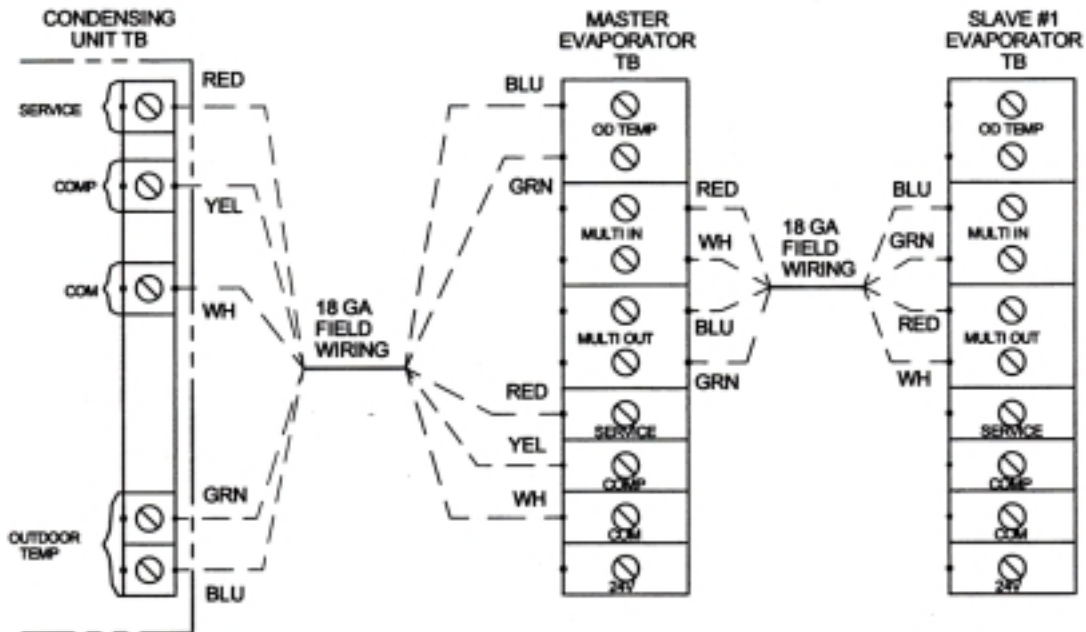

HEATCRAFT PART NO. 29661401
REV B

24 VOLT CONNECTION WIRING - BEACON II

MASTER WITH THREE SLAVE CONNECTION
(CONDENSING UNIT WITH FOUR EVAPORATORS)

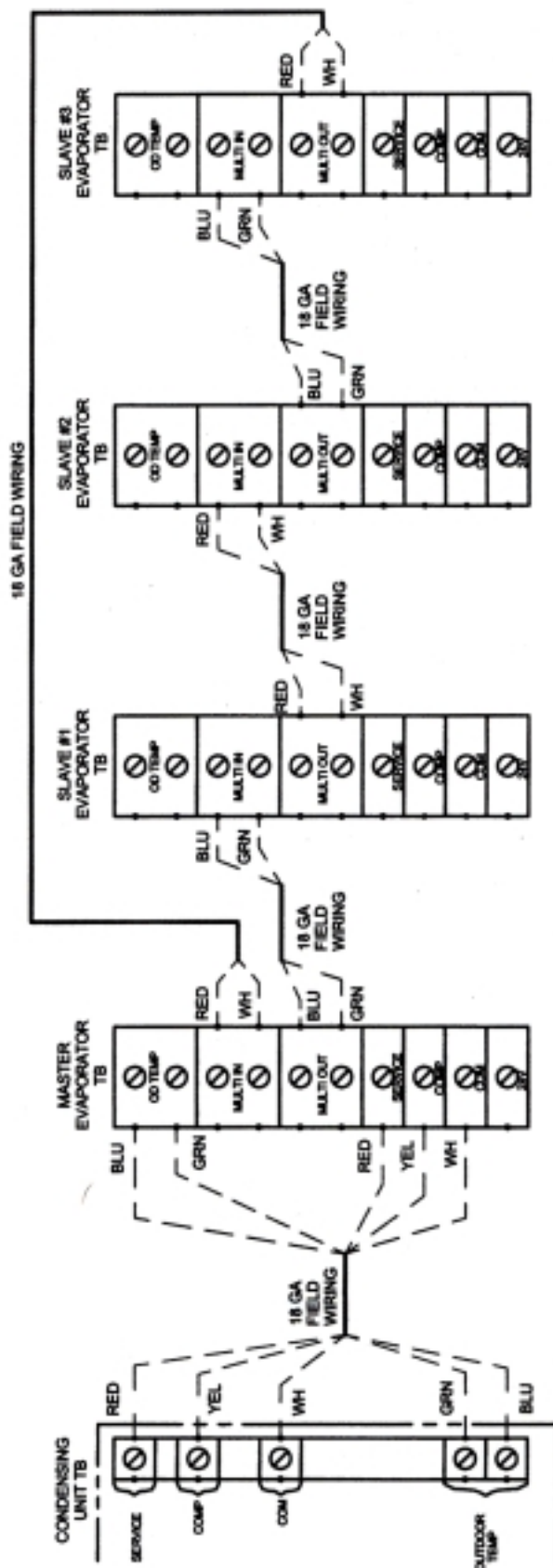

HEATCRAFT PART NO. 20661501
REV B

TYPICAL EVAPORATOR / CONDENSING UNIT 24 VOLT WIRING

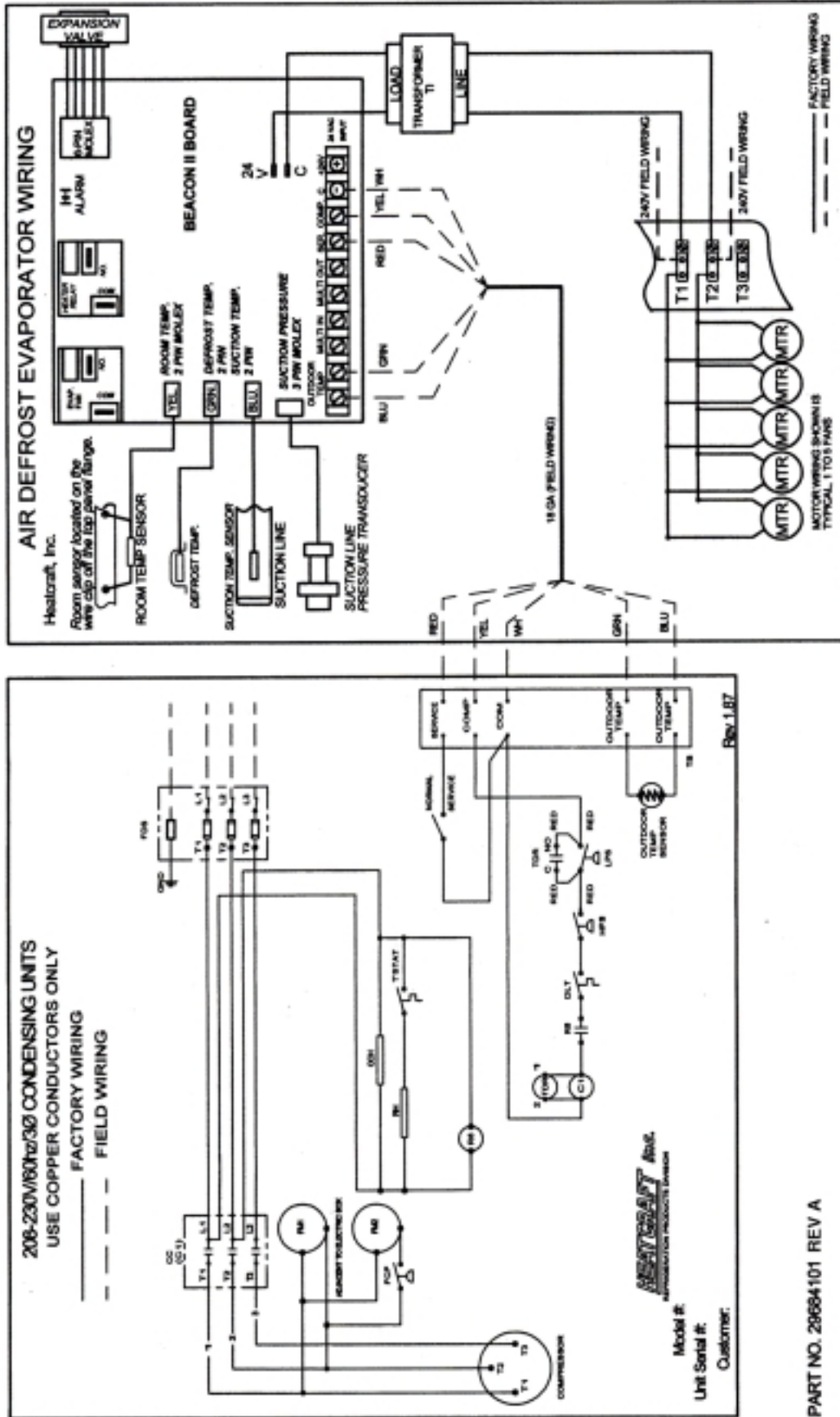

TYPICAL LOW PROFILE EVAPORATOR WIRING

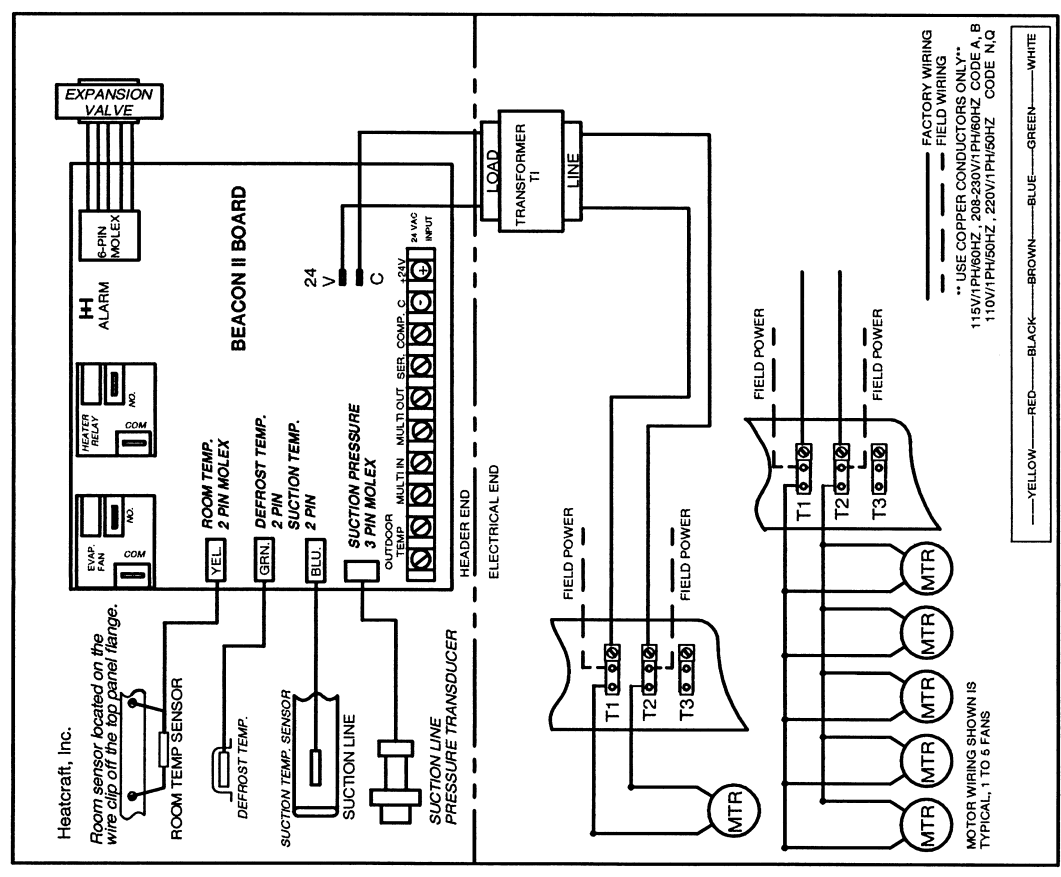

ELECTRIC DEFROST EVAPORATOR WIRING

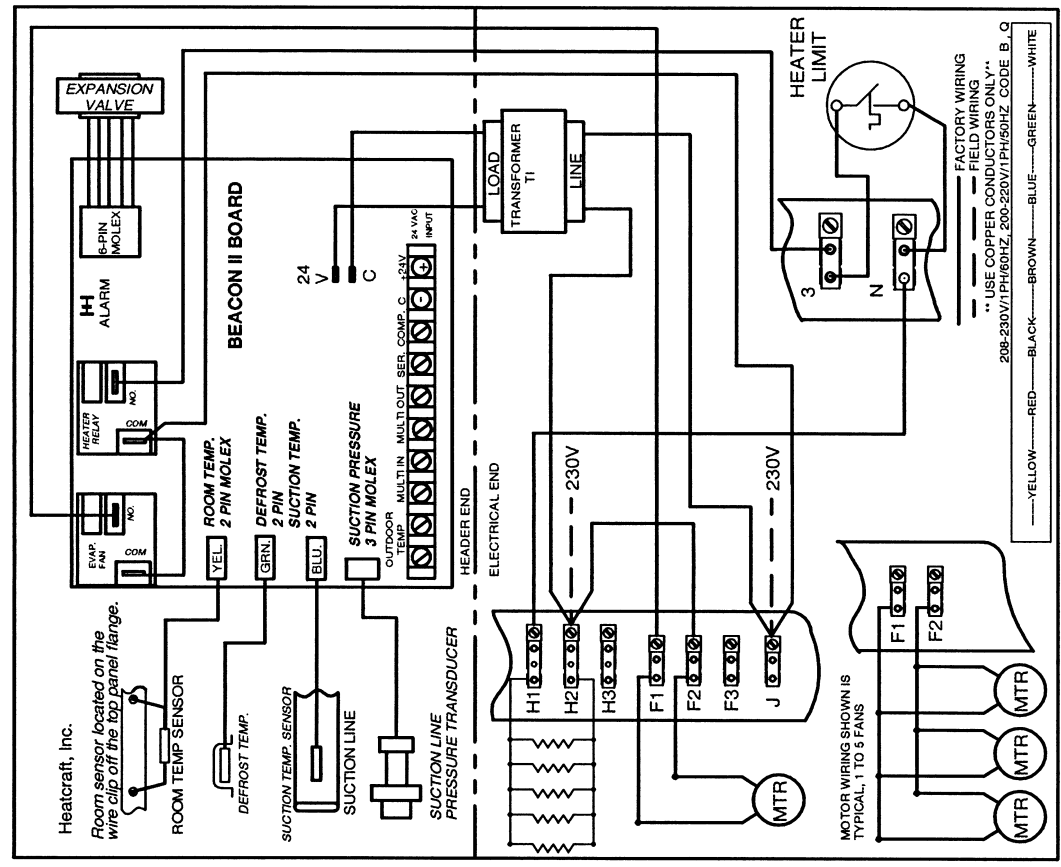

NOTE: THESE ARE TYPICAL EVAPORATOR WIRING DIAGRAMS. CONSULT WIRING DIAGRAM SHIPPED ON UNIT FOR ACTUAL UNIT WIRING.

Part No. 29684301

TYPICAL EVAPORATOR WIRING LARGE UNIT COOLER EVAPORATOR

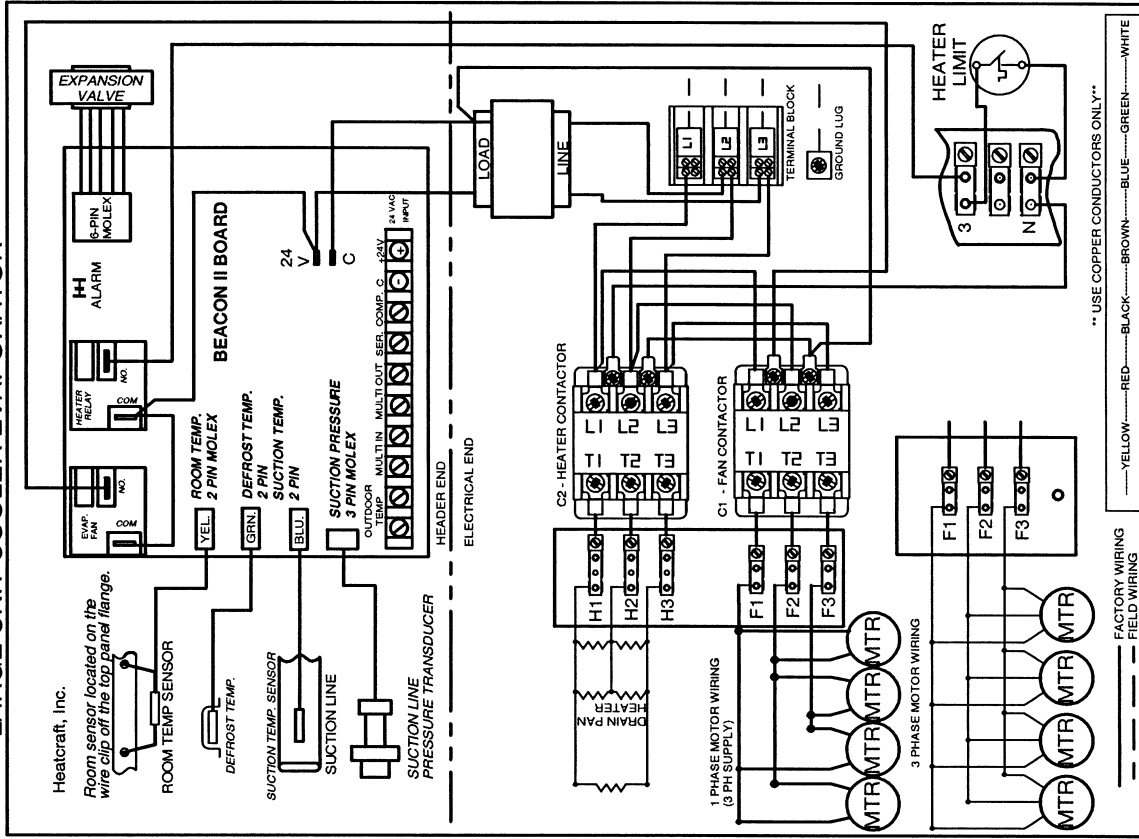

MEDIUM PROFILE EVAPORATOR

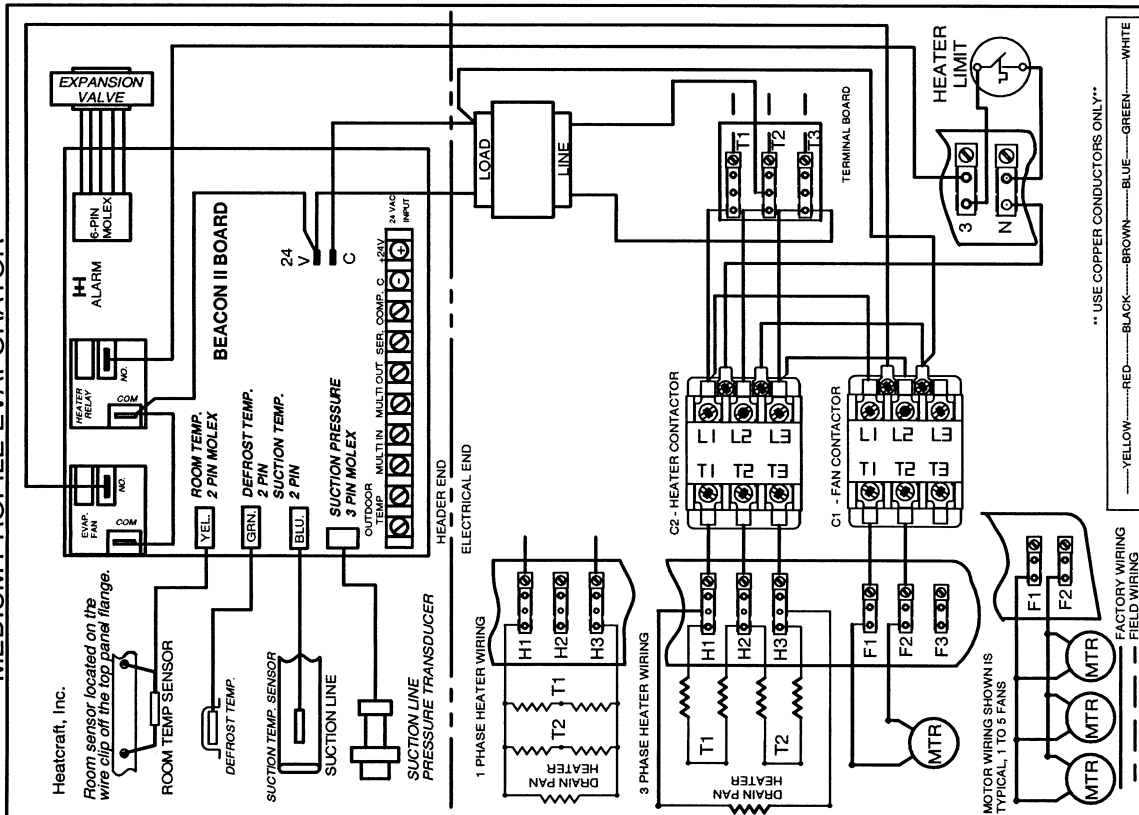

NOTE: THESE ARE TYPICAL EVAPORATOR WIRING DIAGRAMS.
CONSULT WIRING DIAGRAM SHIPPED ON UNIT FOR ACTUAL UNIT WIRING.

Part No. 29684201

TYPICAL CONDENSING UNIT WIRING

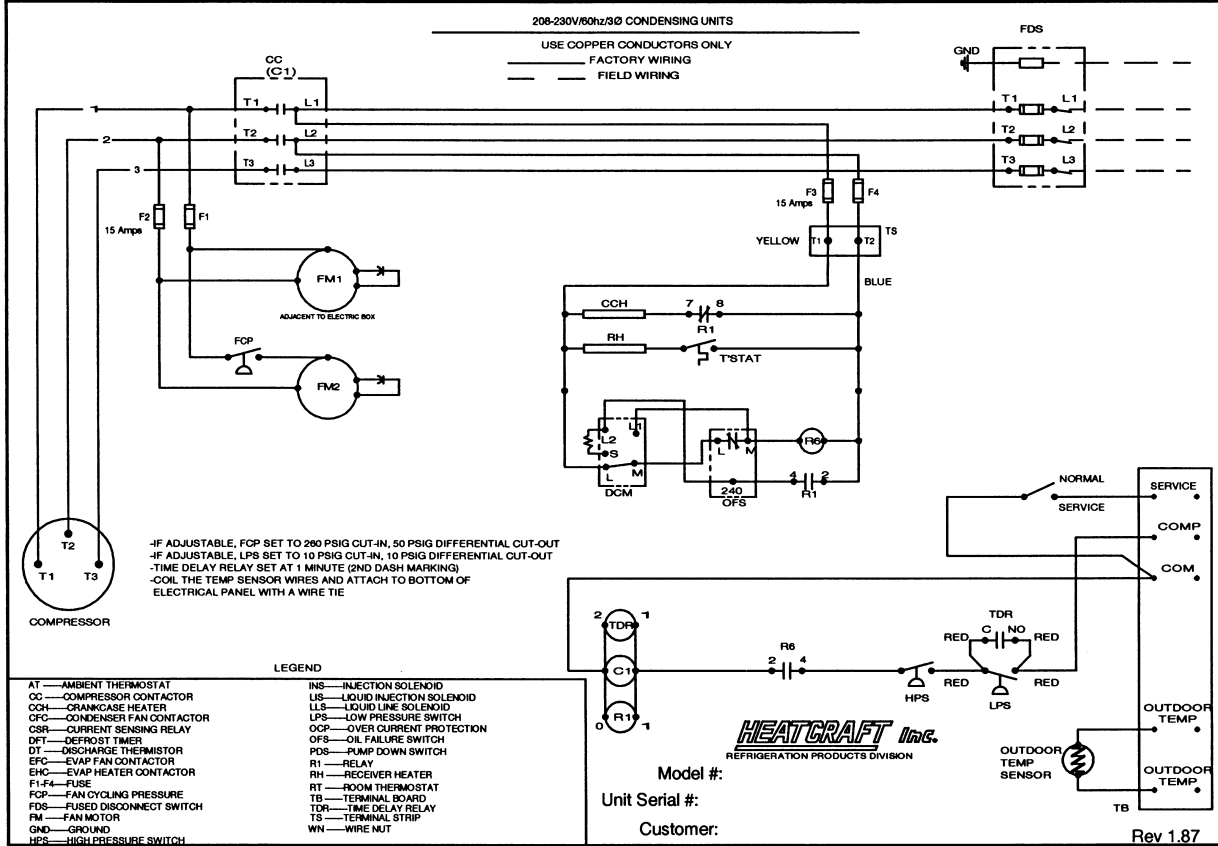

Part No. 29684001

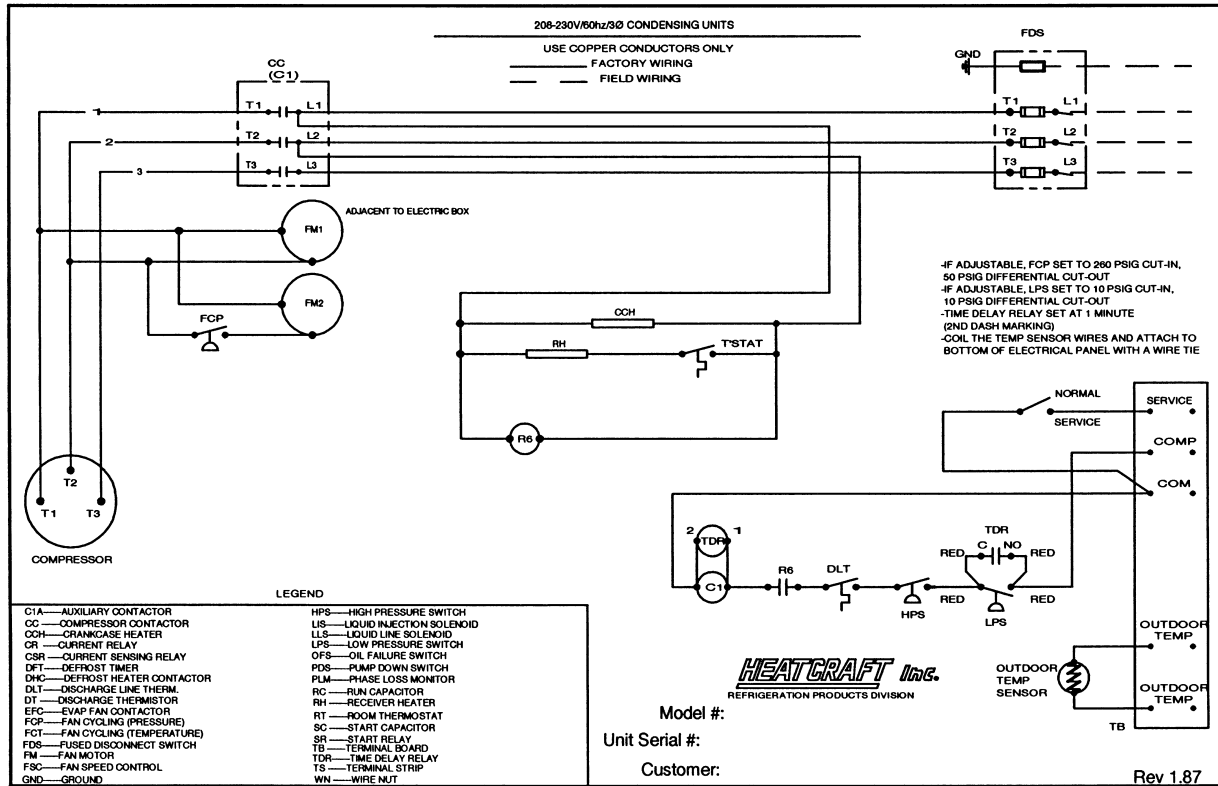

**NOTE: THESE ARE TYPICAL CONDENSING UNIT WIRING DIAGRAMS.
 CONSULT WIRING DIAGRAM SHIPPED ON UNIT FOR ACTUAL UNIT WIRING.**

EVAPORATORS

All evaporator units should be checked once a month or more often for proper defrosting because the amount and pattern of frosting can vary greatly. It is dependent on the coil temperature, the temperature of the room, the type of product being stored, how often new product is brought into the room and the percentage of time the door to the room is open. It may be necessary to periodically change the number of defrost cycles or adjust the duration of defrost.

CONDENSING UNITS / EVAPORATORS

Under normal usage conditions, maintenance should cover the following items at least once every 6 months:

1. Check and tighten ALL electrical connections.
2. Check all wiring and insulators.
3. Check contactors for proper operation and for worn contact points.
4. Check all fan motors. Tighten motor mount bolts and nuts and tighten fan set screws.
5. Clean the condenser coil surface.
6. Check the refrigerant and oil level in the system.
7. Check the operation of the control system. Make certain all safety controls are operating properly.
8. Check that all defrost controls are functioning properly.
9. Clean the evaporator coil surface.
10. Clean the drain pan and check the drain pan and drain line for proper drainage.
11. Check the drain line heater for proper operation, cuts and abrasions.
12. Check and tighten all flare connections.

Check-Out & Start-Up

After the installation has been completed, the following points should be covered before the system is placed in operation:

- (a) Check all electrical and refrigerant connections. Be sure they are all correct and tight.
- (b) Check voltage taps on transformer. The transformer is shipped wired to 240 voltage tap/connection. If your supply voltage is 208 volt systems, change to 208 voltage tap.
- (c) Check setting of time delay relay for low pressure switch in condensing unit. It should be set at one minutes (the second marker).
- (d) Check high and low pressure controls, pressure regulating valves, oil pressure safety controls, and all other safety controls and adjust them, if necessary.
- (e) On freezers only, check the low pressure switch setting. It must be set to 0 PSIG cut out, 10 PSIG cut in, to allow start and operation, especially in cold ambients.
- (f) Liquid line should always be insulated.
- (g) Wiring diagrams, instruction bulletins, etc. attached to the condensing units should be read and filed for future reference.
- (h) All fan motors on air cooled condensers, evaporators, etc. should be checked for proper rotation. Fan motor mounts should be carefully checked for tightness and proper alignment.
- (i) Observe system pressures during charging and initial operation. Do not add oil while the system is short of refrigerant unless oil level is dangerously low.
- (j) Continue charging until system has sufficient refrigerant for proper operation. Do not overcharge. Remember that bubbles in a sight glass may be caused by a restriction as well as a shortage of refrigerant.
- (k) Do not leave unit unattended until the system has reached normal operating conditions and the oil charge has been properly adjusted to maintain the oil level at the center of the sight glass.
- (l) At initial start-up, the system may cycle off at 2 minutes and display a low superheat error, then restart itself. This cycle may be repeated a few times. Do not shut the system off. Let the system run, as it may take a few cycles for the electric expansion valve to attain the correct setting for the desired superheat.

CAUTION: Extreme care must be taken in starting compressors for the first time after system charging. At this time, all of the oil and most of the refrigerant might be in the compressor creating a condition which could cause compressor damage due to slugging. Activating the crankcase heater for 24 hours prior to start-up is recommended. If no crankcase heater is present, then directing a 500 watt heat lamp or other safe heat source on the lower shell of the compressor for approximately thirty minutes will be beneficial in eliminating this condition which might never reoccur.



Service Record

Date of Start-up _____

Location Address _____

CONDENSING UNIT

MODEL # _____

SERIAL # _____

COOLER UNIT

MODEL # _____

SERIAL # _____

FREEZER UNIT

MODEL # _____

SERIAL # _____

ELECTRICAL

- Check Primary Supply voltage.
If 208 V, change transformer wiring in the Cooler and Freezer to the 208 V tap
 YES NO
- Check Compressor Amps for COOLER and FREEZER compressors. Should match nameplate.
 YES NO

PIPING

- Is suction line trapped at the Cooler?
 YES NO
- Is suction line trapped at the Freezer?
 YES NO

DRAIN LINES

- Are drain lines sloped properly?
 YES NO
- Is drain line trapped outside the Cooler?
 YES NO
- Is drain line trapped outside the Freezer?
 YES NO
- Is heat tape wrapped along entire length of the drain line in the Freezer?
 YES NO
- Is heat tape plugged in and heating the drain line?
 YES NO

INSULATION

- Are Liquid lines fully insulated?
 YES NO
- Are Suction lines fully insulated?
 YES NO

SETTINGS

- Check Beacon II board settings for the following:

FREEZER

Refrigerant Type R404A
 Box Setpoint Temp. -10°F.
 Superheat 8°F.
 No. of Defrost/Day 4
 Defrost End Temp. 65°F.

COOLER

Refrigerant Type R22
 Box Setpoint Temp. 35°F.
 Superheat 8°F.
 No. of Defrost/Day 2
 Defrost End Temp. 50°F.

SYSTEM CHECKS

- Check Compressor Superheat for the COOLER (Should be between 20°F. & 30°F.)
 YES NO
- Check Compressor Superheat for the FREEZER (Should be between 20°F. & 30°F.)
 YES NO
- Force unit into a Defrost Check heater amps. Should match nameplate amps.
 YES NO
- Check LPS Time Delay Relays. Should be set at 1 minute for both the COOLER and FREEZER.
 YES NO
- Check Low Pressure Switch on FREEZER. Should be set at 0 psig Cut-out/10 psig Cut-in.
 YES NO
- Did FREEZER and COOLER cycle off on LPS at Setpoint Temperature?
 YES NO
- Is the sight glass free of bubbles?
 YES NO
- Are the COOLER and FREEZER fans at proper speeds?
 YES NO
- Check system for refrigerant leaks. Are there any leaks on the COOLER, FREEZER, CONDENSING UNIT or INTERCONNECTING PIPING?
 YES NO
- Check system piping for unusual vibration or noise. Is there any unusual vibration or noise on the COOLER, FREEZER, CONDENSING UNIT or INTERCONNECTING PIPING?
 YES NO
- Start the FREEZER only. Does the compressor start and evaporator fans run for this FREEZER?
 YES NO



Service Record

RECORD

OUTDOOR TEMPERATURE _____ °F

SYSTEM VOLTAGE _____ Volts _____ PH _____ Hz

Cooler Compressor Amps _____ L1 _____ L2 _____ L3

Freezer Compressor Amps _____ L1 _____ L2 _____ L3

Cooler Discharge Pressure _____ PSIG

Freezer Discharge Pressure _____ PSIG

Cooler Suction Pressure _____ PSIG

Freezer Suction Pressure _____ PSIG

Cooler Suction Temp. _____ °F

Freezer Suction Temp. _____ °F

Cooler Refrigerant Charge _____ lbs.

Freezer Refrigerant Charge _____ lbs.

Cooler Compressor Superheat _____ °F

Freezer Compressor Superheat _____ °F

Cooler Evaporator Superheat _____ °F

Freezer Evaporator Superheat _____ °F

Cooler Discharge Temp. _____ °F

Freezer Discharge Temp. _____ °F



Since product improvement is a continuing effort,
we reserve the right to make changes in specifications without notice.

