

# Panasonic®

Model No.

**TH-60PF50U**  
**TH-65PF50U**

## Operating Instructions

### Display Operations

#### High Definition Plasma Display



**English**

Before connecting, operating or adjusting this product,  
please read these instructions completely.  
Please keep this manual for future reference.

**HDMI**  
**real D 3D**

	<b>CAUTION</b> <b>RISK OF ELECTRIC SHOCK</b> <b>DO NOT OPEN</b>	
<b>WARNING: To reduce the risk of electric shock, do not remove cover or back. No user-serviceable parts inside. Refer servicing to qualified service personnel.</b>		



The lightning flash with arrow-head within a triangle is intended to tell the user that parts inside the product are a risk of electric shock to persons.



The exclamation point within a triangle is intended to tell the user that important operating and servicing instructions are in the papers with the appliance.

**WARNING :** To prevent damage which may result in fire or shock hazard, do not expose this apparatus to rain or moisture.  
**Do not place containers with water (flower vase, cups, cosmetics, etc.) above the set. (including on shelves above, etc.)**

**WARNING :** 1) To prevent electric shock, do not remove cover. No user serviceable parts inside. Refer servicing to qualified service personnel.  
2) Do not remove the grounding pin on the power plug. This apparatus is equipped with a three pin grounding-type power plug. This plug will only fit a grounding-type power outlet. This is a safety feature. If you are unable to insert the plug into the outlet, contact an electrician.  
Do not defeat the purpose of the grounding plug.

# Important Safety Instructions

- 1) Read these instructions.
- 2) Keep these instructions.
- 3) Heed all warnings.
- 4) Follow all instructions.
- 5) Do not use this apparatus near water.
- 6) Clean only with dry cloth.
- 7) Do not block any ventilation openings. Install in accordance with the manufacturer's instructions.
- 8) Do not install near any heat sources such as radiators, heat registers, stoves, or other apparatus (including amplifiers) that produce heat.
- 9) Do not defeat the safety purpose of the polarized or grounding-type plug. A polarized plug has two blades with one wider than the other. A grounding type plug has two blades and a third grounding prong. The wide blade or the third prong are provided for your safety. If the provided plug does not fit into your outlet, consult an electrician for replacement of the obsolete outlet.
- 10) Protect the power cord from being walked on or pinched particularly at plugs, convenience receptacles, and the point where they exit from the apparatus.
- 11) Only use attachments / accessories specified by the manufacturer.
- 12) Use only with the cart, stand, tripod, bracket, or table specified by the manufacturer, or sold with the apparatus. When a cart is used, use caution when moving the cart / apparatus combination to avoid injury from tip-over.
- 13) Unplug this apparatus during lightning storms or when unused for long periods of time.
- 14) Refer all servicing to qualified service personnel. Servicing is required when the apparatus has been damaged in any way, such as power-supply cord or plug is damaged, liquid has been spilled or objects have fallen into the apparatus, the apparatus has been exposed to rain or moisture, does not operate normally, or has been dropped.
- 15) To prevent electric shock, ensure the grounding pin on the AC cord power plug is securely connected.



# Dear Panasonic Customer

Welcome to the Panasonic family of customers. We hope that you will have many years of enjoyment from your new Plasma Display.

To obtain maximum benefit from your set, please read these Instructions before making any adjustments, and retain them for future reference.

Retain your purchase receipt as well, and record the model number and serial number of your set in the space provided on the rear cover of these instructions.

Visit our Panasonic Web Site <http://panasonic.net>

## Table of Contents

<b>Important Safety Instructions</b> .....	<b>3</b>	<b>DAY/TIME SETUP / ON/OFF TIMER SETUP</b> .....	<b>36</b>
<b>Table of Contents</b> .....	<b>4</b>	DAY/TIME SETUP .....	36
<b>FCC STATEMENT</b> .....	<b>5</b>	ON/OFF TIMER SETUP .....	36
<b>Safety Precautions</b> .....	<b>6</b>	<b>3D SETTINGS</b> .....	<b>37</b>
<b>Maintenance</b> .....	<b>7</b>	<b>SCREENSAVER (For preventing image retention)</b> .....	<b>38</b>
3D Safety Precautions.....	8	Setup of SCREENSAVER Time .....	39
<b>Accessories</b> .....	<b>10</b>	<b>Reduces screen image retention</b> .....	<b>40</b>
Accessories Supplied .....	10	EXTENDED LIFE SETTINGS .....	40
Remote Control Batteries .....	10	<b>ECO MODE SETTINGS</b> .....	<b>43</b>
<b>Connections</b> .....	<b>11</b>	<b>Customizing the Input labels</b> .....	<b>44</b>
Speaker connection.....	11	<b>FUNCTION BUTTON SETTINGS</b> .....	<b>45</b>
AC cord connection and fixing, cable fixing.....	11	<b>NO ACTIVITY POWER OFF</b> .....	<b>46</b>
Video equipment connection .....	12	<b>MENU DISPLAY DURATION / OSD BRIGHTNESS</b> ....	<b>46</b>
VIDEO and COMPONENT / RGB IN connection....	12	<b>OSD LANGUAGE</b> .....	<b>46</b>
HDMI connection .....	13	<b>DISPLAY ORIENTATION</b> .....	<b>46</b>
DVI-D IN connection.....	13	<b>SETUP for MULTI DISPLAY</b> .....	<b>47</b>
PC Input Terminals connection.....	14	How to setup MULTI DISPLAY .....	47
SERIAL Terminals connection .....	15	ID Remote Control Function.....	48
<b>Power ON / OFF</b> .....	<b>16</b>	<b>SETUP for PORTRAIT</b> .....	<b>49</b>
<b>Selecting the input signal</b> .....	<b>18</b>	How to setup PORTRAIT .....	49
<b>Basic Controls</b> .....	<b>19</b>	<b>SETUP for Input Signals</b> .....	<b>51</b>
<b>ASPECT Controls</b> .....	<b>21</b>	COMPONENT / RGB IN SELECT.....	51
<b>Digital Zoom</b> .....	<b>22</b>	YUV / RGB IN SELECT .....	51
<b>Viewing 3D images</b> .....	<b>23</b>	SIGNAL menu .....	52
To view the 3D images .....	23	<b>Options Adjustments</b> .....	<b>55</b>
Troubleshooting for 3D Eyewear .....	24	3D Safety Precautions (To hide 3D Safety Precautions) .....	58
Table of images that can be seen for each 3D Picture Format and the source image format .....	24	Weekly Command Timer .....	58
<b>On-Screen Menu Displays</b> .....	<b>25</b>	Audio input select .....	60
<b>Adjusting POS./SIZE</b> .....	<b>26</b>	Touch Panel settings (Settings when using Touch Panel).....	61
<b>PICTURE Adjustments</b> .....	<b>29</b>	Input Search .....	62
ADVANCED SETTINGS.....	30	<b>Troubleshooting</b> .....	<b>63</b>
<b>Picture Profiles</b> .....	<b>31</b>	<b>List of Aspect Modes</b> .....	<b>64</b>
Saving profiles .....	32	<b>Applicable Input Signals</b> .....	<b>65</b>
Loading profiles .....	33	<b>Shipping condition</b> .....	<b>66</b>
Editing profiles .....	33	<b>Command list of Weekly Command Timer</b> .....	<b>67</b>
<b>SOUND Adjustment</b> .....	<b>34</b>	<b>Specifications</b> .....	<b>68</b>
SDI SOUND OUTPUT.....	34		
<b>SETUP menu</b> .....	<b>35</b>		

# FCC STATEMENT

This equipment has been tested and found to comply with the limits for a Class B digital device, pursuant to Part 15 of the FCC Rules. These limits are designed to provide reasonable protection against harmful interference in a residential installation. This equipment generates, uses and can radiate radio frequency energy and, if not installed and used in accordance with the instructions, may cause harmful interference to radio communications. However, there is no guarantee that interference will not occur in a particular installation. If this equipment does cause harmful interference to radio or television reception, which can be determined by turning the equipment off and on, the user is encouraged to try to correct the interference by one or more of the following measures:

- Reorient or relocate the receiving antenna.
- Increase the separation between the equipment and receiver.
- Connect the equipment into an outlet on a circuit different from that to which the receiver is connected.
- Consult the dealer or an experienced technician for help.

This device complies with Part 15 of the FCC Rules. Operation is subject to the following two conditions: (1) This device may not cause harmful interference, and (2) this device must accept any interference received, including interference that may cause undesired operation.

## **FCC CAUTION:**

**To assure continued compliance, follow the attached installation instructions and use only shielded interface cables when connecting to computer or peripheral devices. Any changes or modifications not expressly approved by Panasonic Corp. of North America could void the user's authority to operate this device.**

### FCC Declaration of Conformity

Model No. TH-60PF50U, TH-65PF50U

Responsible Party: Panasonic Corporation of North America  
Three Panasonic Way 2F-5, Secaucus, NJ 07094  
Contact Source: Panasonic System Communications Company of North America  
1-800-973-4390

## **CANADIAN NOTICE:**

This Class B digital apparatus complies with Canadian ICES-003.

## **Note:**

Do not allow a still picture to be displayed for an extended period, as this can cause a permanent image retention to remain on the Plasma Display.

Examples of still pictures include logos, video games, computer images, teletext and images displayed in 4:3 mode.

## **Trademark Credits**

- VGA is a trademark of International Business Machines Corporation.
- Macintosh is a registered trademark of Apple Inc., USA.
- SVGA, XGA, SXGA and UXGA are registered trademarks of the Video Electronics Standard Association.  
Even if no special notation has been made of company or product trademarks, these trademarks have been fully respected.
- HDMI, the HDMI Logo, and High-Definition Multimedia Interface are trademarks or registered trademarks of HDMI Licensing LLC in the United States and other countries.
- "RealD 3D" is a trademark of RealD.

# Safety Precautions



## CAUTION

**This Plasma Display is for use only with the following optional accessories. Use with any other type of optional accessories may cause instability which could result in the possibility of injury.**

(All of the following accessories are manufactured by Panasonic Corporation.)

- Speakers ..... TY-SP58P10WK (for TH-60PF50U),  
TY-SP65P11WK (for TH-65PF50U)
- Pedestal ..... TY-ST58P20 (for TH-60PF50U),  
TY-ST65P20 (for TH-65PF50U)
- Mobile stand ..... TY-ST58PF20 (for TH-60PF50U)
- Mobile Stand for Display ..... TY-ST65PF1 (for TH-65PF50U)
- Wall-hanging bracket (angled) ..... TY-WK65PR20
- BNC Dual Video Terminal Board ..... TY-FB9BD
- HD-SDI Terminal Board ..... TY-FB9HD
- HD-SDI Terminal Board with audio ..... TY-FB10HD
- Dual Link HD-SDI Terminal Board ..... TY-FB11DHD
- Dual HDMI Terminal Board ..... TY-FB10HMD
- DVI-D Terminal Board ..... TY-FB11DD
- Mate-IF Board ..... TY-FB11HB
- AV Terminal Box ..... TY-TB10AV
- 3D IR TRANSMITTER ..... TY-3D30TRW
- Touch Panel ..... TY-TP60P30K (for TH-60PF50U), TY-TP65P30K (for TH-65PF50U)
- 3D Eyewear ..... TY-EW3D3SU, TY-EW3D3MU, TY-EW3D3LU
- Wireless Module ..... ET-WM200U

Always be sure to ask a qualified technician to carry out set-up.

Small parts can present choking hazard if accidentally swallowed. Keep small parts away from young children. Discard unneeded small parts and other objects, including packaging materials and plastic bags/sheets to prevent them from being played with by young children, creating the potential risk of suffocation.

### ■ When using the Plasma Display

**Do not bring your hands, face or objects close to the ventilation holes of the Plasma Display.**

- Top of the Plasma Display is usually very hot due to the high temperature of exhaust air being released through the ventilation holes. Burns or personal injuries can happen if any body parts are brought too close. Placing any object near the top of the display could also result in heat damages to the object as well as to the Display if its ventilation holes are blocked.

**Be sure to disconnect all cables before moving the Plasma Display.**

- Moving the Display with its cables attached might damage the cables which, in turn, can cause fire or electric shock.

**Disconnect the power plug from the wall outlet as a safety precaution before carrying out any cleaning.**

- Electric shocks can result if this is not done.

**Clean the power cable regularly to prevent it from becoming dusty.**

- Built-up dust on the power cord plug can increase humidity which might damage the insulation and cause fire. Unplug the cord from the wall outlet and clean it with a dry cloth.

**This Plasma Display radiates infrared rays, therefore it may affect other infrared communication equipment. Install your infrared sensor in a place away from direct or reflected light from your Plasma Display.**

#### **Note:**

Do not allow a still picture to be displayed for an extended period, as this can cause a permanent image retention to remain on the Plasma Display.

Examples of still pictures include logos, video games, computer images, teletext and images displayed in 4:3 mode.

## WARNING

### ■ Setup

**Do not place the Plasma Display on sloped or unstable surfaces, and ensure that the Plasma Display does not hang over the edge of the base.**

- The Plasma Display may fall off or tip over.

**Do not place any objects on top of the Plasma Display.**

- If water spills onto the Plasma Display or foreign objects get inside it, a short-circuit may occur which could result in fire or electric shock. If any foreign objects get inside the Plasma Display, please consult an Authorized Service Center.

**Do not cover the ventilation holes.**

- Doing so may cause the Plasma Display to overheat, which can cause fire or damage to the Plasma Display.

**Transport only in upright position!**

- Transporting the unit with its display panel facing upright or downward may cause damage to the internal circuitry.

**If using the pedestal (optional accessory), leave a space of 3 15/16" (10 cm) or more at the top, left and right, and 2 3/4" (7 cm) or more at the rear, and also keep the space between the bottom of the display and the floor surface. If using some other setting-up method, follow the manual of it. (If there is no specific indication of installation dimension in the installation manual, leave a space of 3 15/16" (10 cm) or more at the top, bottom, left and right, and 2 3/4" (7 cm) or more at the rear.)**

**When installing the Plasma Display vertically;**

Turn up the power switch for the upward direction when you install the Plasma Display vertically.

And set "DISPLAY ORIENTATION" to "PORTRAIT" in SETUP menu. (see page 46)

**An apparatus with CLASS I construction shall be connected to a mains socket outlet with a protective earthing connection.**

### ■ AC Power Supply Cord

**The Plasma Display is designed to operate on 110 - 127 V AC, 50/60 Hz.**

**Ensure that the mains plug is easily accessible.**

**Do not use any power supply cord other than that provided with this unit.**

- Doing so may cause fire or electric shocks.

**Securely insert the power cord plug as far as it will go.**

- If the plug is not fully inserted, heat may be generated which could cause fire. If the plug is damaged or the wall socket plate is loose, they should not be used.

**Do not handle the power cord plug with wet hands.**

- Doing so may cause electric shocks.

**Do not do anything that might damage the power cable. When disconnecting the power cable, hold the plug, not the cable.**

- Do not make any modifications, place heavy objects on, place near hot objects, heat, bend, twist or forcefully pull the power cable. Doing so may cause damage to the power cable which can cause fire or electric shock. If damage to the cable is suspected, have it repaired at an Authorized Service Center.

**If the Plasma Display will not be used for a long period of time, unplug the power cord from the wall outlet.**

### ■ If problems occur during use

**If a problem occurs (such as no picture or no sound), or if smoke or an abnormal odor is detected from the Plasma Display, unplug the power cord immediately.**

- Continuous use of the Display under these conditions might cause fire or permanent damage to the unit. Have the Display evaluated at an Authorized Service Center. Services to the Display by any unauthorized personnel are strongly discouraged due to its high voltage dangerous nature.

**If water or foreign objects get inside the Plasma Display, if the Plasma Display is dropped, or if the cabinet becomes damaged, disconnect the power cord plug immediately.**

- A short may occur, which could cause fire. Contact an Authorized Service Center for any repairs that need to be made.

## Maintenance

**The front of the display panel has been specially treated. Wipe the panel surface gently using only a cleaning cloth or a soft, lint-free cloth.**

- If the surface is particularly dirty, wipe with a soft, lint-free cloth which has been soaked in pure water or water in which neutral detergent has been diluted 100 times, and then wipe it evenly with a dry cloth of the same type until the surface is dry.
- Do not scratch or hit the surface of the panel with fingernails or other hard objects, otherwise the surface may become damaged. Furthermore, avoid contact with volatile substances such as insect sprays, solvents and thinner, otherwise the quality of the surface may be adversely affected.

**If the cabinet becomes dirty, wipe it with a soft, dry cloth.**

- If the cabinet is particularly dirty, soak the cloth in water to which a small amount of neutral detergent has been added and then wring the cloth dry. Use this cloth to wipe the cabinet, and then wipe it dry with a dry cloth.
- Do not allow any detergent to come into direct contact with the surface of the Plasma Display. If water droplets get inside the unit, operating problems may result.
- Avoid contact with volatile substances such as insect sprays, solvents and thinner, otherwise the quality of the cabinet surface may be adversely affected or the coating may peel off. Furthermore, do not leave it for long periods in contact with articles made from rubber or PVC.

### 3D Safety Precautions

---

#### **WARNING**

##### ■ Small Parts

3D Eyewear contains small parts (battery and specialized band, etc.) and must be kept out of reach of small children to avoid accidental ingestion.

##### ■ Disassembly

Do not disassemble or modify the 3D Eyewear.



#### **CAUTION**

To enjoy 3D images safely and comfortably, please read these instructions fully.

##### ■ Use for commercial applications and public viewing

Someone in authority should responsibly convey the precautions for use of the 3D Eyewear to the user.

##### ■ 3D Eyewear (sold separately)

Do not drop, exert pressure on, or step on the 3D Eyewear.

Be careful of the tips of the frame when putting on the 3D Eyewear.

Be careful not to trap a finger in the hinge section of the 3D Eyewear.

Pay special attention when children are using the 3D Eyewear.

3D Eyewear should not be used by children younger than 5 - 6 years old, as a guideline.

All children must be fully supervised by parents or guardians who must ensure their safety and health throughout the using 3D Eyewear.



## ■ Viewing 3D Content

Content for 3D viewing includes commercially available Blu-ray discs, 3D broadcasts, etc. When preparing your own 3D content, ensure that it is properly produced.

Do not use the 3D Eyewear if you have a history of over-sensitivity to light, heart problems, or have any other existing medical conditions.

Please stop using the 3D Eyewear immediately, if you feel tired, are not feeling well or experience any other uncomfortable sensation.

Take an appropriate break after viewing a 3D movie.

Take a break of between 30 - 60 minutes after viewing 3D content on interactive devices such as 3D games or computers.

Be careful not to strike the screen or other people unintentionally. When using the 3D Eyewear the distance between the user and screen can be misjudged.

The 3D Eyewear must only be worn when viewing 3D content.

If you do not look toward the screen for a while when viewing 3D images, the 3D Eyewear may be turned off automatically.

If you suffer from any eyesight problems (short / far-sighted, astigmatism, eyesight differences in left and right), please ensure to correct your vision before using the 3D Eyewear.

Stop using the 3D Eyewear if you can clearly see double images when viewing 3D content.

Do not use the 3D Eyewear at a distance less than the recommended distance.

View from at least the recommended distance (3 times the effective height of the screen).

Recommended distance

TH-60PF50U: 86.7"/2.2 m

TH-65PF50U: 94.5"/2.4 m

When the top and bottom area of the screen is blackened, such as movies, view the screen at a distance 3 times further than the height of the actual image. (That makes the distance closer than above recommended figure.)

## ■ 3D Eyewear (sold separately) Use

Before using the 3D Eyewear, ensure no breakable objects surrounding the user to avoid any accidental damage or injury.

Remove the 3D Eyewear before moving around to avoid falling or accidental injury.

Use the 3D Eyewear only for the intended purpose and nothing else.

Do not use 3D Eyewear in the condition of high temperature.

Do not use if the 3D Eyewear is physically damaged.

Do not use any devices that emit the infrared signals near the 3D Eyewear, as this may cause the 3D Eyewear false operations.

Do not use devices (such as mobile phones or personal transceivers) that emit strong electromagnetic waves near the 3D Eyewear as this may cause the 3D Eyewear to malfunction.

Stop using the 3D Eyewear immediately if a malfunction or fault occurs.

Stop using the 3D Eyewear immediately if you experience any redness, pain, or skin irritation around the nose or temples.

In rare cases, the materials used in the 3D Eyewear may cause an allergic reaction.

# Accessories

## Accessories Supplied

Check that you have the Accessories and items shown

Operating  
Instruction book

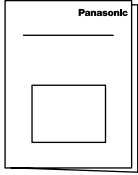

CD-ROM × 1

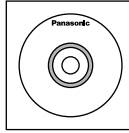

- Operating Instructions
- Display Operations
- Network Operations
- Software license statements
- GNU GENERAL PUBLIC LICENSE
- GNU LESSER GENERAL PUBLIC LICENSE

Remote Control Transmitter  
N2QAYB000691



Batteries for the  
Remote Control  
Transmitter  
(AA Size × 2)

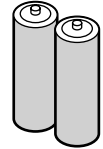

Clamper × 1  
TMME289

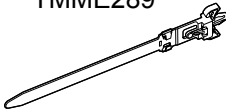

AC cord

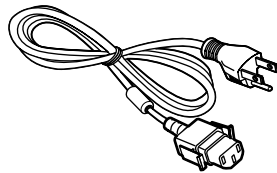

Ferrite core × 2  
J0KG00000014

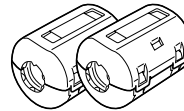

Use the Ferrite cores to comply with the EMC standard.  
(refer to “Operating Instructions, Network Operations”)

## Remote Control Batteries

Requires two AA batteries.

1. Pull and hold the hook, then open the battery cover.
2. Insert batteries - note correct polarity (+ and -).
3. Replace the cover.

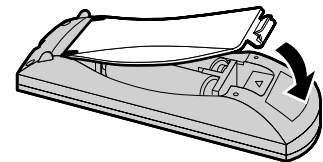
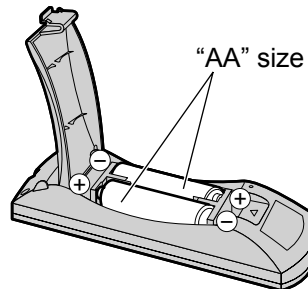
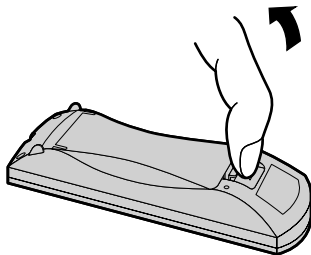

### Helpful Hint:

For frequent remote control users, replace old batteries with Alkaline batteries for longer life.

### ⚠️ Precaution on battery use

Incorrect installation can cause battery leakage and corrosion that will damage the remote control transmitter. Disposal of batteries should be in an environment-friendly manner.

#### Observe the following precautions:

1. Batteries should always be replaced as a pair. Always use new batteries when replacing the old set.
2. Do not combine a used battery with a new one.
3. Do not mix battery types (example: “Zinc Carbon” with “Alkaline”).
4. Do not attempt to charge, short-circuit, disassemble, heat or burn used batteries.
5. Battery replacement is necessary when the remote control acts sporadically or stops operating the Plasma Display.
6. Do not burn or breakup batteries.
7. Batteries must not be exposed to excessive heat such as sunshine, fire or the like.

# Connections

## Speaker connection

When connecting the speakers, be sure to use only the optional accessory speakers. Refer to the speaker's Installation Manual for details on speaker installation.

Speakers (Optional accessories)

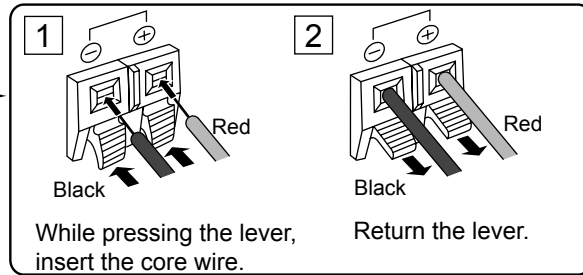
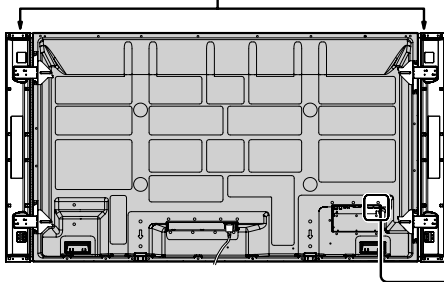

## AC cord connection and fixing, cable fixing

AC cord fixing

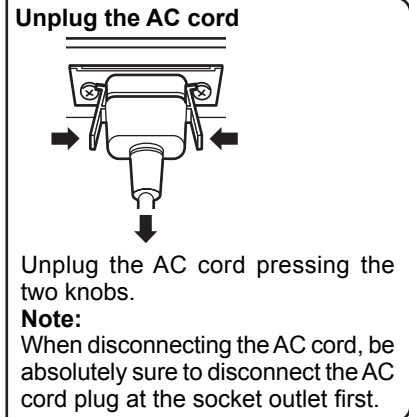
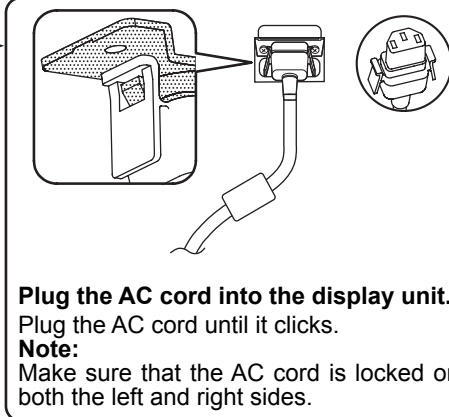
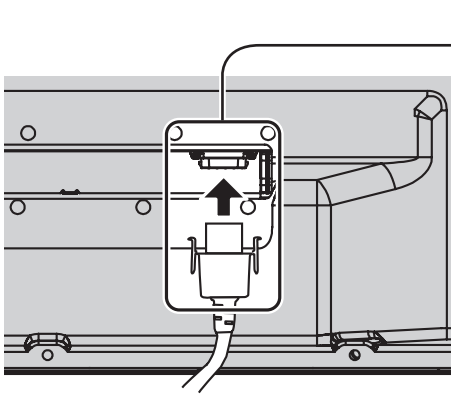

### Using the clamper

Secure any excess cables with clamper as required.

**Note:**

One clamper is supplied with this unit. In case of securing cables at three positions, please purchase it separately.

TH-60PF50U

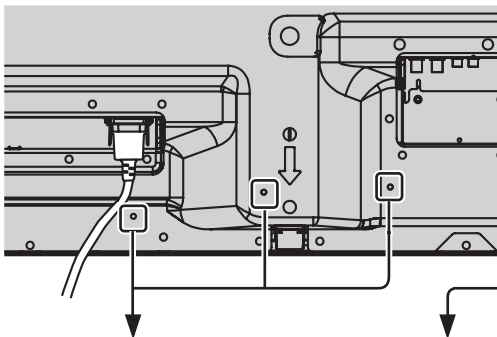

TH-65PF50U

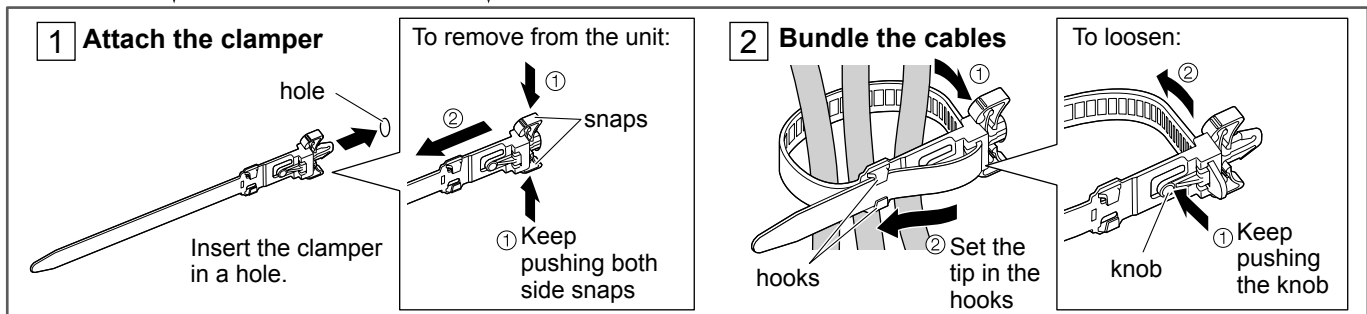
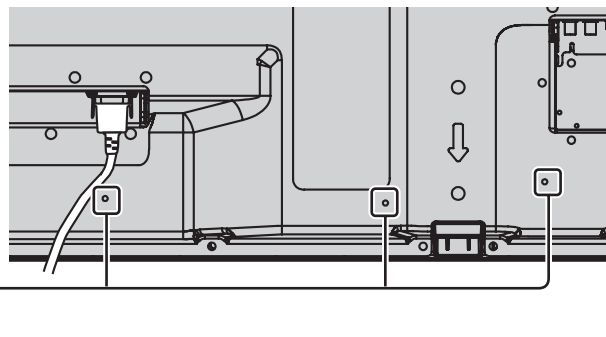

# Connections

## Video equipment connection

Ex. TH-65PF50U

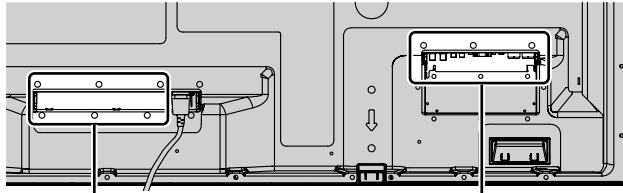

Terminals are on the bottom side of the Plasma Display.

**SERIAL:**  
Control the Plasma Display by connecting to PC. (see page 15)

**3D IR TRANSMITTER:**  
Connect the 3D IR TRANSMITTER (optional accessory).

**SLOT:** Terminal board (optional accessories) insert slot (see page 6)

**Note:**

The right side slot is for terminal board with 2-slot width. The terminal board with 1-slot width does not function when installed in the right side slot.

**AV IN (VIDEO):** Composite Video Input Terminal (see below)

**COMPONENT/RGB IN:** Component/RGB Video Input Terminal (see below)

**DVI-D IN:** DVI-D Input Terminal (see page 13)

**PC IN:** PC Input Terminal Connect to video terminal of PC or equipment with Y, P<sub>B</sub>(C<sub>B</sub>) and P<sub>R</sub>(C<sub>R</sub>) output. (see page 14)

**AV IN (HDMI):**  
HDMI Input Terminal (see page 13)  
Connect to video equipment such as VCR or DVD player.

**WIRELESS MODULE, LAN:**  
Refer to "Operating Instructions, Network Operations".

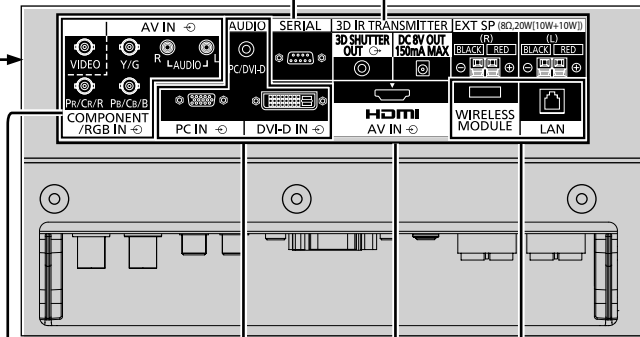

## VIDEO and COMPONENT / RGB IN connection

**Note:**

Additional equipment, cables and adapter plugs shown are not supplied with this set.

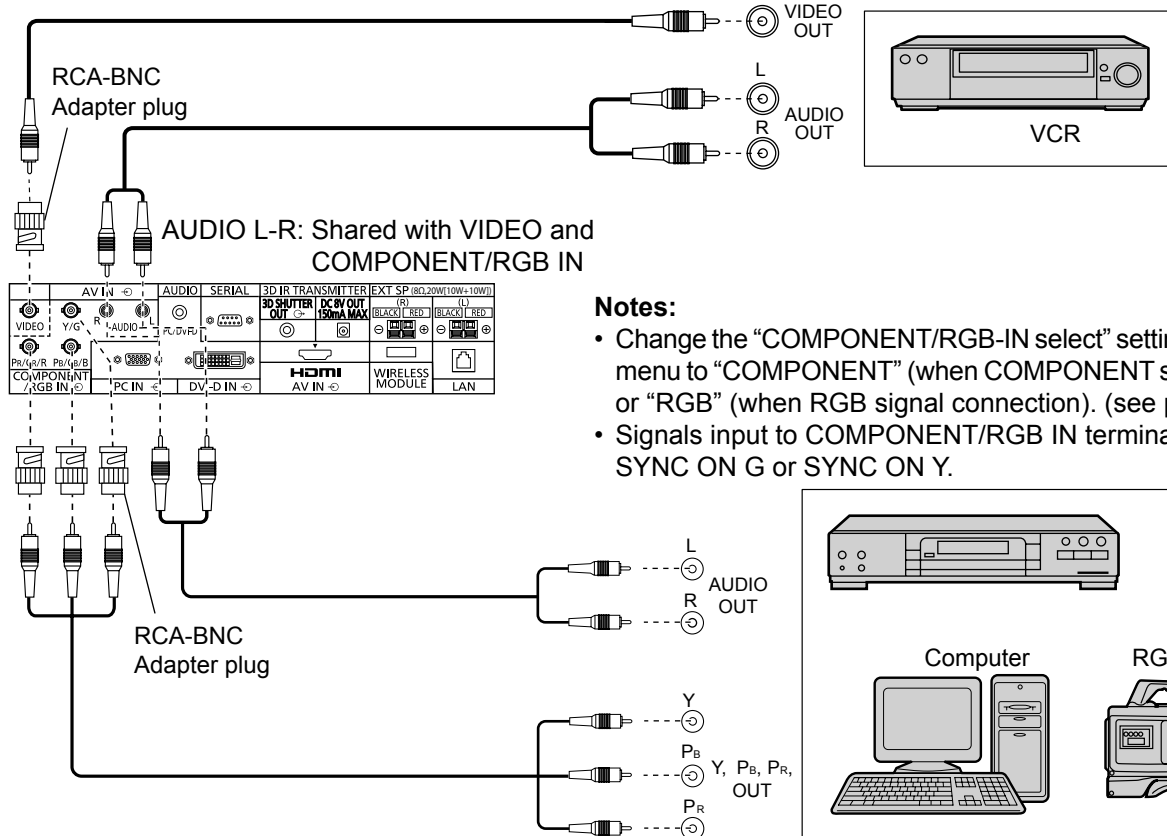

**Notes:**

- Change the "COMPONENT/RGB-IN select" setting in the "SETUP" menu to "COMPONENT" (when COMPONENT signal connection) or "RGB" (when RGB signal connection). (see page 51)
- Signals input to COMPONENT/RGB IN terminals correspond to SYNC ON G or SYNC ON Y.

# HDMI connection

[Pin assignments and signal names]

Pin No.	Signal Name	Pin No.	Signal Name
①	T.M.D.S Data2+	⑪	T.M.D.S Clock Shield
②	T.M.D.S Data2 Shield	⑫	T.M.D.S Clock-
③	T.M.D.S Data2-	⑬	CEC
④	T.M.D.S Data1+	⑭	Reserved (N.C. on device)
⑤	T.M.D.S Data1 Shield		
⑥	T.M.D.S Data1-	⑮	SCL
⑦	T.M.D.S Data0+	⑯	SDA
⑧	T.M.D.S Data0 Shield	⑰	DDC/CEC Ground
⑨	T.M.D.S Data0-	⑱	+5V Power
⑩	T.M.D.S Clock+	⑲	Hot Plug Detect

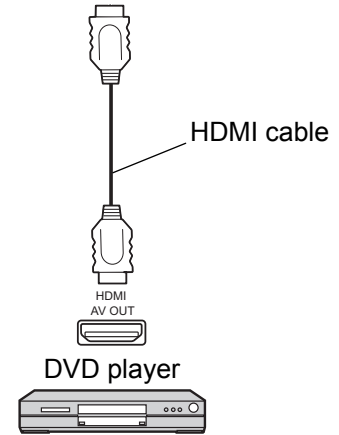
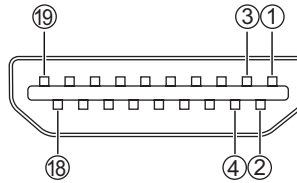
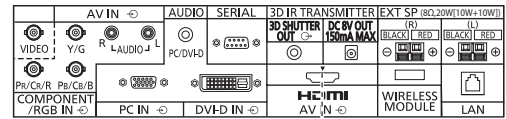

**Note:**

Additional equipment and HDMI cable shown are not supplied with this set.

# DVI-D IN connection

PC with DVI-D video out

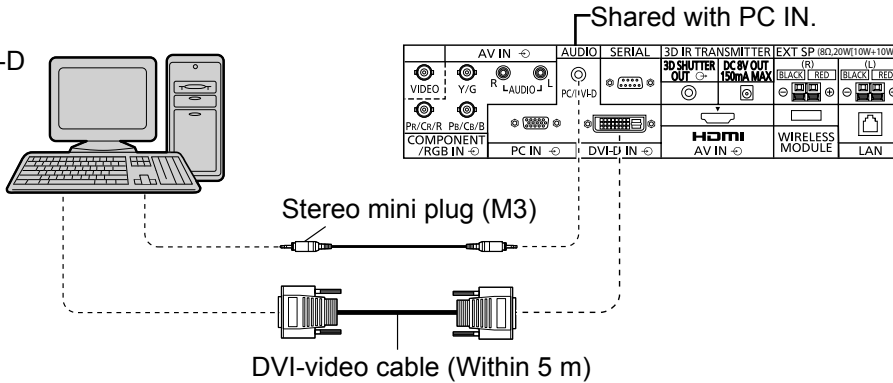

**DVI-D Input Connector Pin Layouts**

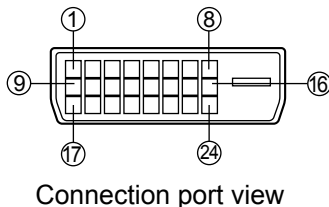

Pin No.	Signal Name	Pin No.	Signal Name
①	T.M.D.S. data 2-	⑬	_____
②	T.M.D.S. data 2+	⑭	+5 V DC
③	T.M.D.S. data 2 shield	⑮	Ground
④	_____	⑯	Hot plug detect
⑤	_____	⑰	T.M.D.S. data 0-
⑥	DDC clock	⑱	T.M.D.S. data 0+
⑦	DDC data	⑲	T.M.D.S. data 0 shield
⑧	_____	⑳	_____
⑨	T.M.D.S. data 1-	㉑	_____
⑩	T.M.D.S. data 1+	㉒	T.M.D.S. clock shield
⑪	T.M.D.S. data 1 shield	㉓	T.M.D.S. clock+
⑫	_____	㉔	T.M.D.S. clock-

**Notes:**

- Additional equipment and cables shown are not supplied with this set.
- Use the DVI-D cable complying with the DVI standard. Image deterioration may occur depending on the length or the quality of the cable.

## PC Input Terminals connection

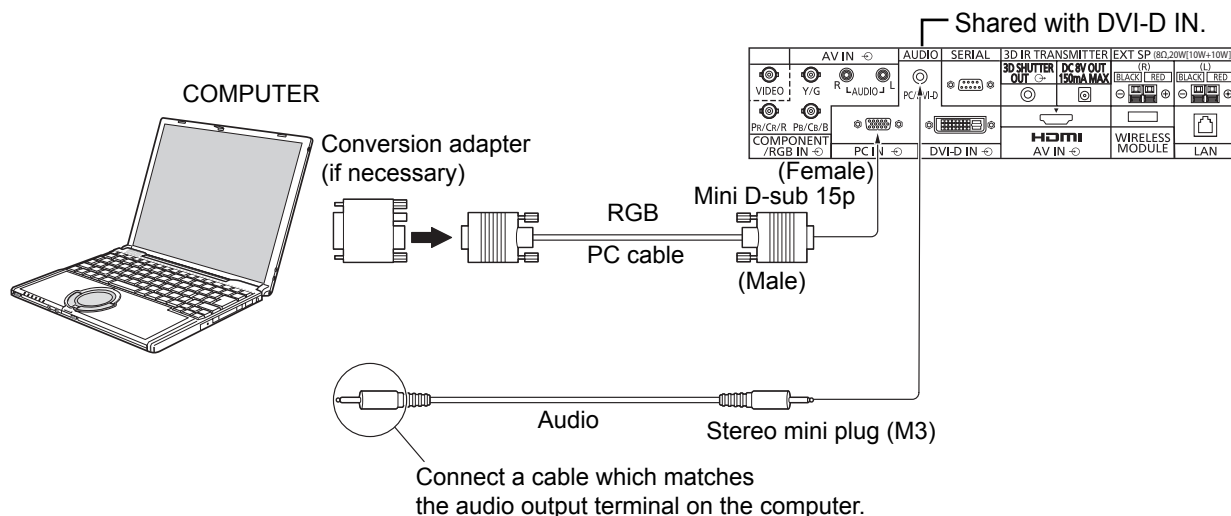

### Notes:

- With regard to the typical PC input signals that are described in the applicable input signals list (see page 65), adjustment values such as for the standard picture positions and sizes have already been stored in this unit. You can add up to eight PC input signal types that are not included in the list.
- Computer signals which can be input are those with a horizontal scanning frequency of 15 to 110 kHz and vertical scanning frequency of 48 to 120 Hz. (However, the image will not be displayed properly if the signals exceed 1,200 lines.)
- The display resolution is a maximum of 1,440 × 1,080 dots when the aspect mode is set to “4:3”, and 1,920 × 1,080 dots when the aspect mode is set to “FULL”. If the display resolution exceeds these maximums, it may not be possible to show fine detail with sufficient clarity.
- The PC input terminals are DDC2B-compatible. If the computer being connected is not DDC2B-compatible, you will need to make setting changes to the computer at the time of connection.
- Some PC models cannot be connected to the set.
- There is no need to use an adapter for computers with DOS/V compatible Mini D-sub 15P terminal.
- The computer shown in the illustration is for example purposes only.
- Additional equipment and cables shown are not supplied with this set.
- Do not set the horizontal and vertical scanning frequencies for PC signals which are above or below the specified frequency range.
- Component Input is possible with the pin 1, 2, 3 of the Mini D-sub 15P Connector.
- Change the “COMPONENT/RGB-IN SELECT” setting in the “SETUP” menu to “COMPONENT” (when COMPONENT signal connection) or “RGB” (when RGB signal connection). (see page 51)

### Signal Names for Mini D-sub 15P Connector

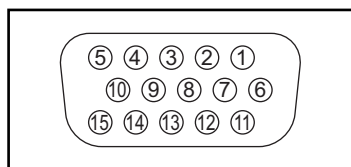

Pin Layout for PC Input Terminal

Pin No.	Signal Name	Pin No.	Signal Name	Pin No.	Signal Name
①	R (P <sub>R</sub> /C <sub>R</sub> )	⑥	GND (Ground)	⑪	NC (not connected)
②	G (Y)	⑦	GND (Ground)	⑫	SDA
③	B (P <sub>B</sub> /C <sub>B</sub> )	⑧	GND (Ground)	⑬	HD/SYNC
④	NC (not connected)	⑨	+5 V DC	⑭	VD
⑤	GND (Ground)	⑩	GND (Ground)	⑮	SCL

# SERIAL Terminals connection

The SERIAL terminal is used when the Plasma Display is controlled by a computer.

**Note:** To use serial control for this unit, make sure to set the “CONTROL I/F SELECT” in the “NETWORK SETUP” menu to “RS-232C”. (refer to “Operating Instructions, Network Operations”)

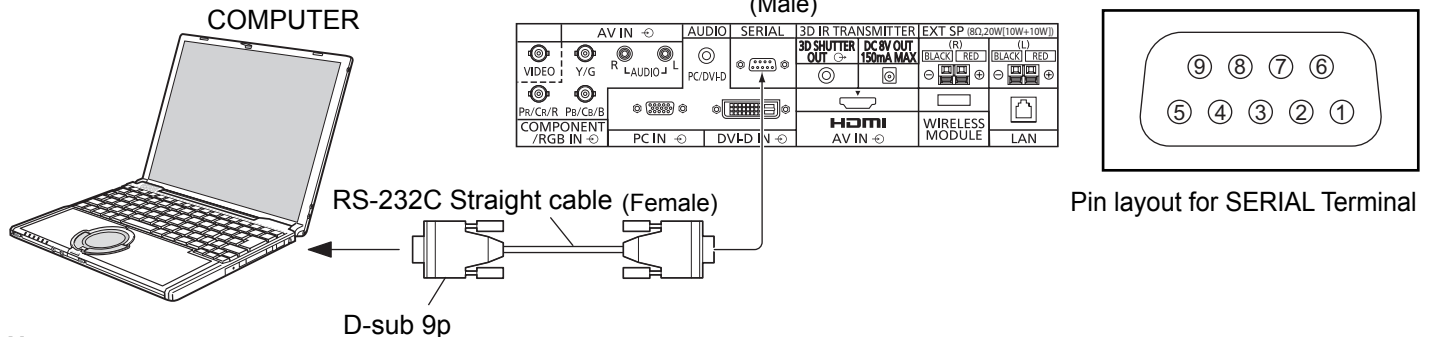

**Notes:**

- Use the RS-232C straight cable to connect the computer to the Plasma Display.
- The computer shown is for example purposes only.
- Additional equipment and cables shown are not supplied with this set.

The SERIAL terminal conforms to the RS-232C interface specification, so that the Plasma Display can be controlled by a computer which is connected to this terminal.

The computer will require software which allows the sending and receiving of control data which satisfies the conditions given below. Use a computer application such as programming language software. Refer to the documentation for the computer application for details.

**Communication parameters**

Signal level	RS-232C compliant
Synchronization method	Asynchronous
Baud rate	9600 bps
Parity	None
Character length	8 bits
Stop bit	1 bit
Flow control	-

**Basic format for control data**

The transmission of control data from the computer starts with a STX signal, followed by the command, the parameters, and lastly an ETX signal in that order. If there are no parameters, then the parameter signal does not need to be sent.

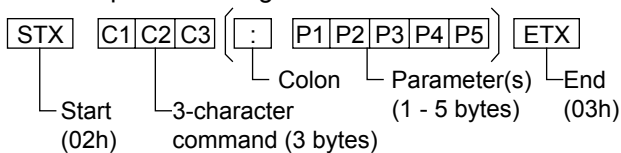

**Notes:**

- If multiple commands are transmitted, be sure to wait for the response for the first command to come from this unit before sending the next command.
- If an incorrect command is sent by mistake, this unit will send an “ER401” command back to the computer.
- S1A and S1B of Command IMS are available only when a dual input terminal board is attached.
- Consult an Authorized Service Center for detail instructions on command usage.

**Signal names for D-sub 9P connector**

Pin No.	Details
②	R X D
③	T X D
⑤	GND
④ • ⑥	Non use
⑦ ⑧	(Shorted in this set)
① • ⑨	NC

These signal names are those of computer specifications.

**Command**

Command	Parameter	Control details
PON	None	Power ON
POF	None	Power OFF
AVL	**	Volume 00 - 63
AMT	0	Audio MUTE OFF
	1	Audio MUTE ON
IMS	None	Input select (toggle)
	SL1	SLOT input (SLOT INPUT)
	S1A	SLOT input (SLOT INPUT A)
	S1B	SLOT input (SLOT INPUT B)
	VD1	VIDEO input (VIDEO)
	YP1	COMPONENT/RGB IN input (COMPONENT)
	HM1	HDMI input (HDMI)
	DV1	DVI-D IN input (DVI)
	PC1	PC IN input (PC)
	NW1	Network input (NETWORK)
DAM	None	Screen mode select (toggle)
	ZOOM	ZOOM (For Video/SD/PC signal)
	FULL	FULL
	JUST	JUST (For Video/SD signal)
	NORM	4:3 (For Video/SD/PC signal)
	SJST	JUST (For HD signal)
	SNOM	4:3 (For HD signal)
	SFUL	H-FILL (For HD signal)
ZOM2	ZOOM (For HD signal)	

With the power off, this display responds to PON command only.

# Power ON / OFF

Connecting the AC cord plug to the Plasma Display.

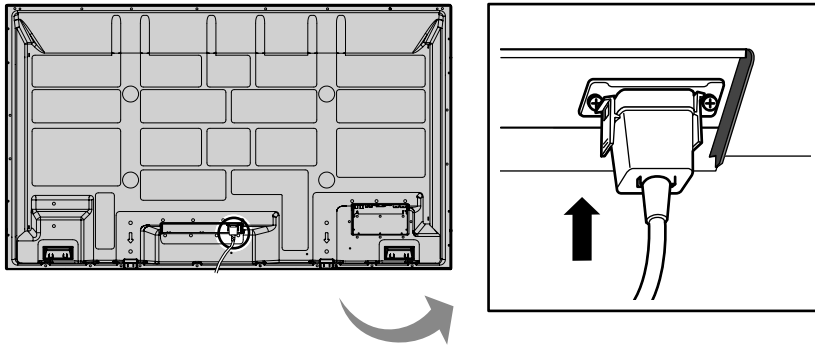

Connecting the plug to the Wall Outlet.

**Note:**

When disconnecting the AC cord, be absolutely sure to disconnect the AC cord plug at the socket outlet first.

Press the Power switch on the Plasma Display to turn the set on: Power-On.

Power Indicator: Green

**[Starting up the network]**

It takes some time for the network to start up just after the power is turned on.

During that time, "NETWORK SETUP" in the "SETUP" menu is grayed out and cannot be set.

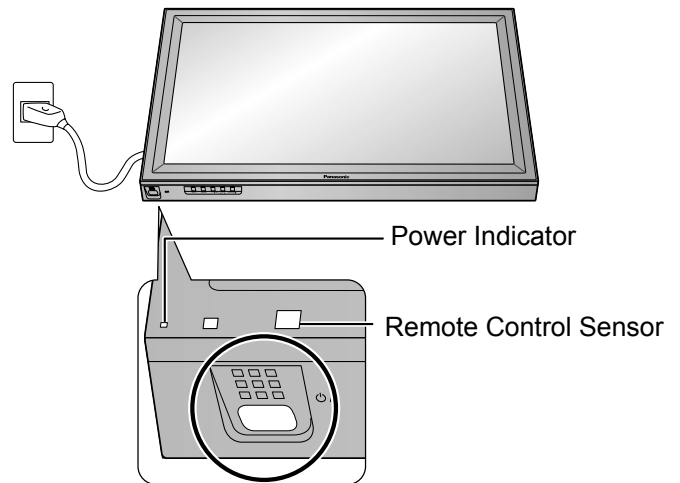

Press the  button on the remote control to turn the Plasma Display off.

Power Indicator: Red (standby)

Press the  button on the remote control to turn the Plasma Display on.

Power Indicator: Green

Turn the power to the Plasma Display off by pressing the  switch on the unit, when the Plasma Display is on or in standby mode.

**Note:**

During operation of the power management function, the power indicator turns orange in the power off state.





**When first switching on the unit**

Following screen will be displayed when the unit is turned on for the first time. Select the items with the remote control. Unit buttons are invalid.

**OSD LANGUAGE**

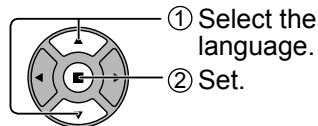

**VIEWING ENVIRONMENT**

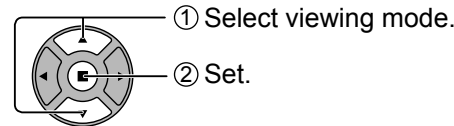

**PUBLIC SPACE:**

Suitable for commercial applications.

**HOME:**

Suitable for home environment.

**DAY/TIME SETUP**

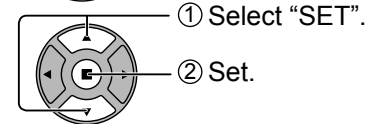
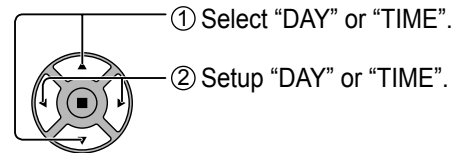
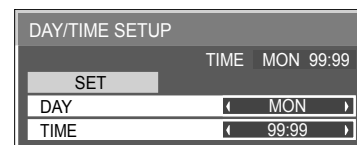

**DISPLAY ORIENTATION**

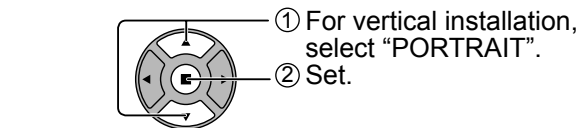

**Notes:**

- Once the items are set, the screens won't be displayed when switching on the unit next time.
- After the setting, the items can be changed in the following menus.
  - OSD LANGUAGE (see page 46)
  - DAY/TIME SETUP (see page 36)
  - DISPLAY ORIENTATION (see page 46)

**Power ON warning message**

The following message may be displayed when turning the unit power ON:

**3D Safety Precautions**

When 3D images will be viewed by unspecified number of people or used for commercial applications, someone in authority should convey the following precautions. These precautions should be followed in the home as well.

To enjoy 3D images safely and comfortably, please refer to the Operating Instructions for in-depth description. Please refrain from viewing 3D images if you do not feel well or are experiencing visual fatigue.

Activate 3D Safety Precautions if you deliver 3D images to unspecified audiences for business or other purposes. If "3D FUNCTION" in "3D SETTINGS" is set to "ON", a warning message is displayed every time the power is turned ON. (see page 37)

**No activity power off Precautions**

'NO ACTIVITY POWER OFF' IS ENABLED.

If "NO ACTIVITY POWER OFF" in SETUP menu is set to "ENABLE", a warning message is displayed every time the power is turned ON. (see page 46)

These message displays can be set with the following menu: Options menu

3D Safety Precautions (see page 58)

Power On Message (see page 57)

# Selecting the input signal

INPUT



Press to select the input signal to be played back from the equipment which has been connected to the Plasma Display.

Input signals will change as follows:

→ PC → NETWORK → VIDEO → COMPONENT\* → HDMI → DVI

PC: PC input terminal in PC IN.

NETWORK: Network input terminal in LAN or WIRELESS MODULE.

VIDEO: Video input terminal in AV IN (VIDEO).

COMPONENT\*: Component or RGB input terminal in COMPONENT/RGB IN.

HDMI: HDMI input terminal in AV IN (HDMI).

DVI: DVI input terminal in DVI-D IN.

\* "COMPONENT" may be displayed as "RGB" depending on the setting of "COMPONENT/RGB-IN SELECT". (see page 51)

When an optional Terminal Board is installed:

→ PC → NETWORK → SLOT INPUT → VIDEO → COMPONENT → HDMI → DVI

SLOT INPUT: Input terminal in Terminal Board

**Note:**

When a Terminal Board incompatible with the Plasma Display is installed, "NON-COMPATIBLE FUNCTION BOARD" is displayed.

When a Terminal Board with dual input terminals is installed:

→ PC → NETWORK → SLOT INPUT A → SLOT INPUT B → VIDEO → COMPONENT → HDMI → DVI

SLOT INPUT A, SLOT INPUT B: Dual input terminal in Terminal Board.

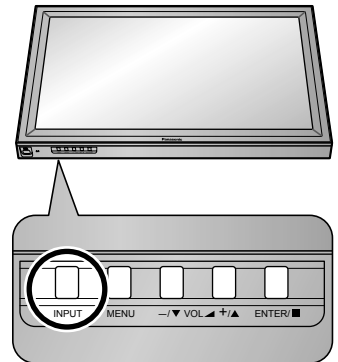

**Notes:**

- Selecting is also possible by pressing the INPUT button on the unit.
- Outputs the sound as set in "Audio input select" in the Options menu.(see page 60)
- Select to match the signals from the source connected to the component/RGB input terminals. (see page 51)
- Image retention (image lag) may occur on the plasma display panel when a still picture is kept on the panel for an extended period. The function that darkens the screen slightly is activated to prevent image retention (see page 63), but this function is not the perfect solution to image retention.

# Basic Controls

## Main Unit

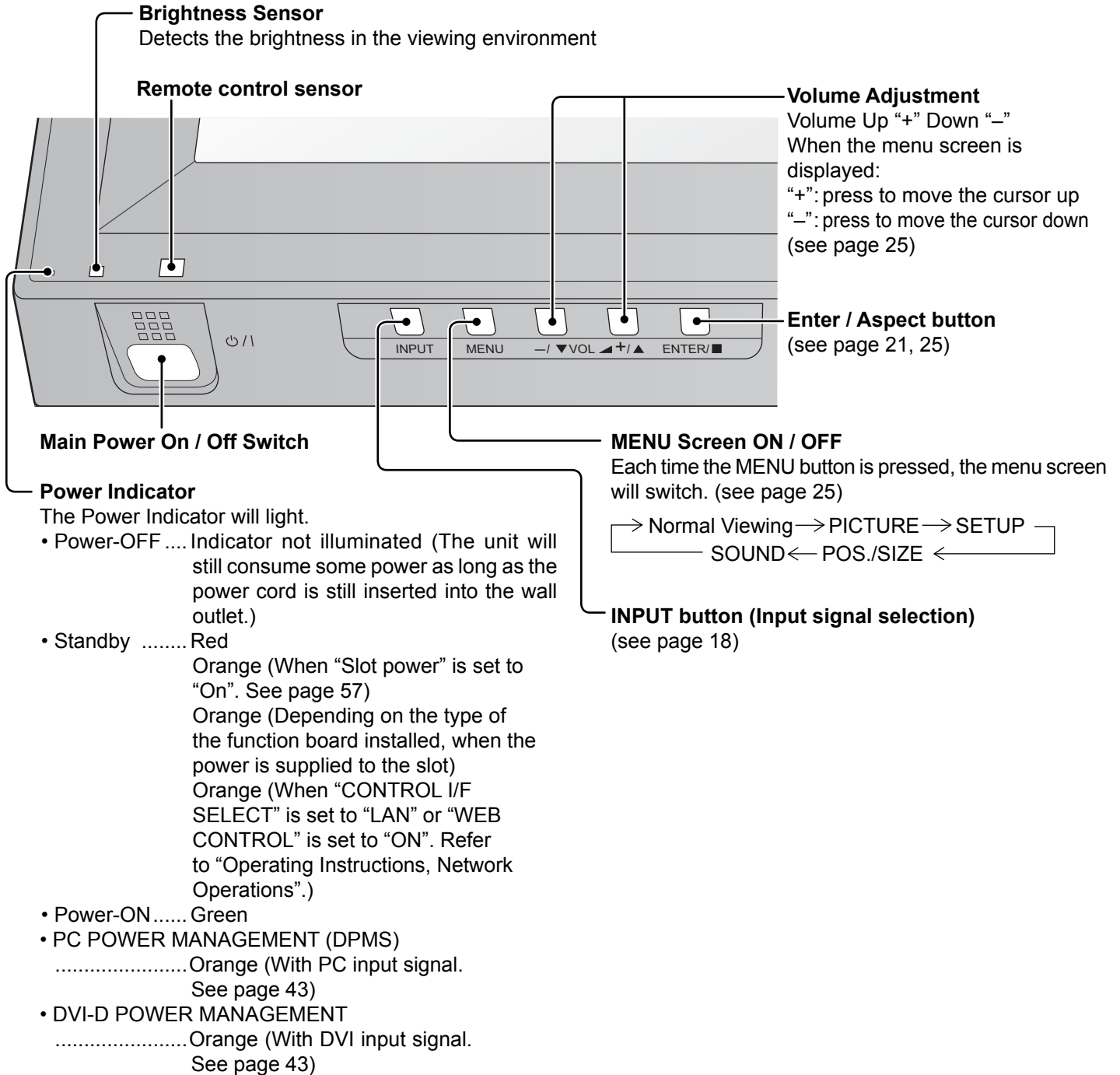

## Remote Control Transmitter

### ACTION button

Press to make selections.

### ASPECT button

Press to adjust the aspect.  
(see page 21)

### Standby (ON / OFF) button

The Plasma Display must first be plugged into the wall outlet and turned on at the power switch (see page 16). Press this button to turn the Plasma Display On, from Standby mode. Press it again to turn the Plasma Display Off to Standby mode.

### POS. /SIZE button

(see page 26)

### PICTURE button

(see page 29)

### Sound mute On / Off

Press this button to mute the sound. Press again to reactivate sound. Sound is also reactivated when power is turned off or volume level is changed.

### N button

(see page 28, 29, 30, 34)

### POSITION buttons

### INPUT button

Press to select input signal sequentially.  
(see page 18)

### ECO MODE (ECO)

Press to change the ECO MODE setup status. (see page 43)

### FUNCTION buttons (FUNCTION)

(see page 45)

### OFF TIMER button

The Plasma Display can be preset to switch to standby after a fixed period. The setting changes to 30 minutes, 60 minutes, 90 minutes and 0 minutes (off timer cancelled) each time the button is pressed.

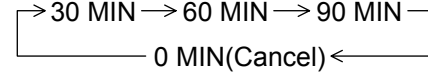

When three minutes remain, "OFF TIMER 3 MIN" will flash.

The off timer is cancelled if a power interruption occurs.

### AUTO SETUP button

Automatically adjusts the position/size of the screen. (see page 26)

### SETUP button

(see page 35)

### SOUND button

(see page 34)

### Volume Adjustment

Press the Volume Up "+" or Down "-" button to increase or decrease the sound volume level.

### R button

(see page 25)  
Press the R button to return to previous menu screen.

### RECALL button

Press the "RECALL" button to display the current system status.

- ① Input label
- ② Aspect mode (see page 21)  
During 3D images (see page 37)  
Audio input (see page 60)  
Profile name (see page 33)  
NANODRIFT SAVER operating (see page 41)
- ③ Off timer  
The off timer indicator is displayed only when the off timer has been set.
- ④ Clock display (see page 57)

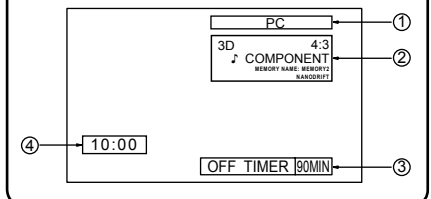

### Digital Zoom

(see page 22)

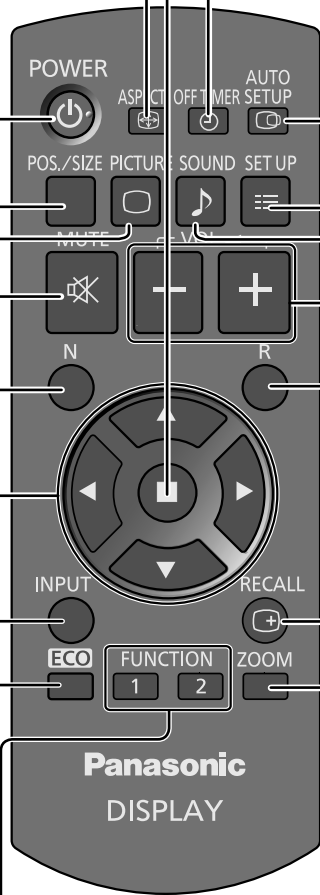

# ASPECT Controls

The Plasma Display will allow you to enjoy viewing the picture at its maximum size, including wide screen cinema format picture.

**Note:**

Be aware that if you put the display in a public place for commercial purposes or a public showing and then use the aspect mode select function to shrink or expand the picture, you may be violating the copyright under copyright law. It is prohibited to show or alter the copyrighted materials of other people for commercial purposes without the prior permission of the copyright holder.



Press repeatedly to move through the aspect options:  
For details about the aspect mode, please see "List of Aspect Modes" (page 64).

[from the unit]



The aspect mode changes each time the ENTER button is pressed.

For VIDEO (S VIDEO) signal input:

→ 4:3 → ZOOM → FULL → JUST

For PC signal input:

→ 4:3 → ZOOM → FULL

For SD signal input (525 (480) / 60i • 60p, 625 (575) / 50i • 50p):

→ 4:3 → ZOOM → FULL → JUST

For HD signal input [1125 (1080) / 60i • 50i • 60p • 50p • 24p • 25p • 30p • 24sF, 1250 (1080) / 50i, 750 (720) / 60p • 50p]:

→ 4:3 → H-FILL → ZOOM → FULL → JUST

[For 3D images]

The aspect is fixed as "FULL" and you cannot switch.

**Notes:**

- The aspect mode is memorized separately for each input terminal.
- Do not allow the picture to be displayed in 4:3 mode for an extended period, as this can cause a permanent image retention to remain on the Plasma Display Panel.

**All Aspect mode**

Set "All Aspect" to "On" in Options menu to enable the extended aspect mode (page 57). When All Aspect mode, the aspect mode of pictures is switched as follows. For details about the aspect mode, please see "List of Aspect Modes" (page 64).

For VIDEO (S VIDEO) signal input:

→ 4:3 → Zoom1 → Zoom2 → Zoom3 → 16:9 → 14:9 → Just

For PC signal input:

→ 4:3 → Zoom → 16:9

For SD signal input (525 (480) / 60i • 60p, 625 (575) / 50i • 50p):

→ 4:3 → Zoom1 → Zoom2 → Zoom3 → 16:9 → 14:9 → Just

For HD signal input [1125 (1080) / 60i • 50i • 60p • 50p • 24p • 25p • 30p • 24sF, 1250 (1080) / 50i, 750 (720) / 60p • 50p]:

→ 4:3 Full → Zoom1 → Zoom2 → Zoom3 → 16:9 → 14:9 → Just1 → Just2 → 4:3 (1) → 4:3 (2)



# Digital Zoom

This displays an enlargement of the designated part of the displayed image.

## 1 Display the operation guide.

 Press to access Digital Zoom.  
The operation guide will be displayed.

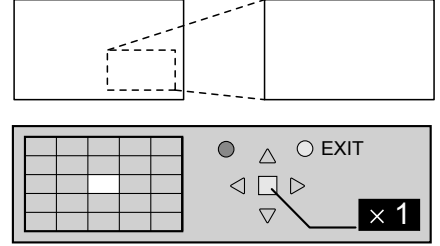

**During Digital Zoom, only the following buttons can be operated.**

[Remote control]

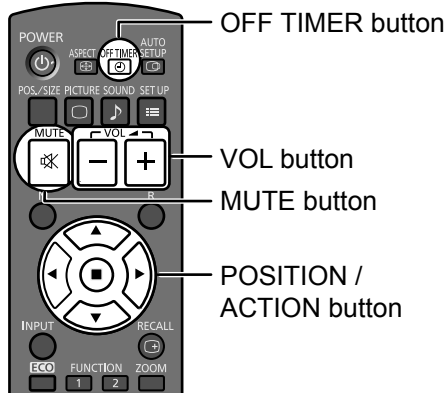

[Unit]

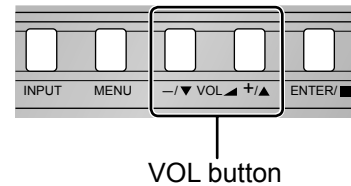

## 2 Select the area of the image to be enlarged.

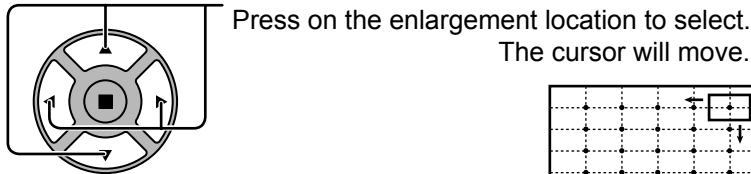

Press on the enlargement location to select.  
The cursor will move.

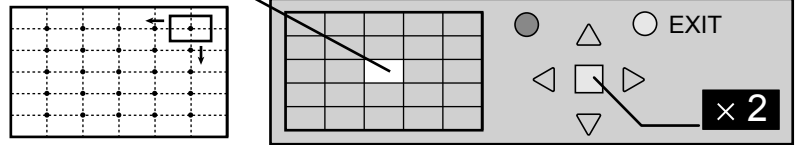

## 3 Select the magnification required for the enlarged display.

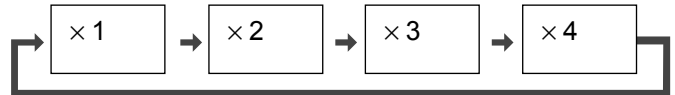
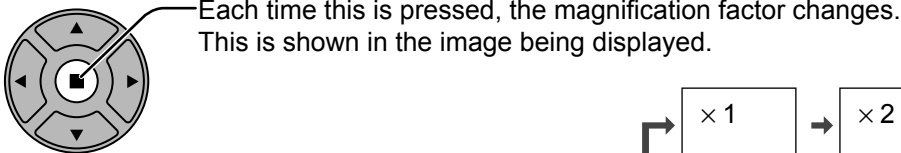

## 4 Return to normal display (quit Digital Zoom).

 Press to exit from the Digital Zoom.

### Notes:

- When power goes OFF (including “Off Timer” operation), Digital Zoom terminates.
- The Digital Zoom function cannot be selected while in the following operation state:
  - During 3D image (see page 37).
  - When MULTI DISPLAY SETUP is ON (see page 47).
  - When PORTRAIT SETUP is ON (see page 49).
  - When SCREENSAVER (except for NEGATIVE IMAGE) is running. (see page 38)
- While Digital Zoom is in operation, “Adjusting POS./SIZE” cannot be used.

# Viewing 3D images

You can enjoy viewing 3D images with contents or programmes compatible with 3D effect by using the 3D eyewear (optional).

**Note:**

You need the 3D IR TRANSMITTER (optional) and the 3D eyewear (optional) to view the 3D images on this display. For further information, see the instruction manuals of the 3D IR TRANSMITTER and the 3D eyewear.

This display supports “Frame Sequential”<sup>\*1</sup>, “SIDE BY SIDE”<sup>\*2</sup> and “TOP AND BOTTOM”<sup>\*3</sup> 3D formats.

\*1: The 3D format that the images for the left and right eyes are recorded with the high definition quality and alternately played back

\*2, \*3: See “Table of images that can be seen for each 3D Picture Format and the source image format” on page 24.

---

## To view the 3D images

---

### To view the contents of the Frame Sequential format (ex. 3D-compatible Blu-ray Disc, etc.) with 3D effect

Connect the 3D-compatible player via an HDMI cable (see page 10) and playback the contents.

- Use fully wired HDMI compliant cable.
- For the settings of the player, read the manual of the player.
- If you use the non 3D-compatible player, the images will be displayed without 3D effect.

### To view the contents of 3D formats other than Frame Sequential with 3D effect.

Match the picture format in “3D INPUT FORMAT” (see page 37) before viewing.

- You can view “SIDE BY SIDE” and “TOP AND BOTTOM” with 3D effect even if you use the non 3D-compatible player.
- Please consult the suppliers of contents or programmes for availability of this service.

① **Turn the 3D Eyewear on**

- See the instruction manual of 3D eyewear for handling.

② **Put on the 3D Eyewear**

③ **Watch the 3D images**

**Notes:**













- If the room is lit by fluorescent lights and light appears to flicker when using the 3D Eyewear, switch off the fluorescent light. Alternatively, please set “3D REFRESH RATE” to “100Hz” or “120Hz” whichever reduces flicker. (see page 53)
- 3D content will not be correctly visible if the 3D Eyewear is worn upside down or back-to-front.
- Do not wear the 3D Eyewear when watching anything other than 3D images. Liquid crystal displays (such as computer screens, digital clocks or calculators, etc.) may be difficult to see while wearing the 3D Eyewear.
- Do not use the 3D Eyewear as sunglasses.
- 3D effects may be perceived differently depending on the person.

## Troubleshooting for 3D Eyewear

Symptoms	Checks
Cannot see 3D images	<ul style="list-style-type: none"> <li>• Has the 3D Eyewear been switched On?</li> <li>• Ensure that “3D FUNCTION” in “3D SETTINGS” is set to “ON”. (see page 37)</li> <li>• Some 3D image signals may not be automatically recognized as 3D images. Set “3D INPUT FORMAT” in “3D SETTINGS” to match the picture format. (see page 37)</li> <li>• Check if 3D IR TRANSMITTER is turned on and corrected properly.</li> <li>• Check that there are no obstacles between the 3D IR TRANSMITTER and the 3D Eyewear. If the 3D Eyewear stops receiving the infrared signal for about 5 minutes, the 3D Eyewear will be turned off automatically.</li> <li>• Check the available area to use the 3D Eyewear.</li> <li>• Depending on the person, the 3D images may be difficult to see, or cannot be seen, especially in users that have a different level of eyesight between the left and right eyes. Take the necessary steps (wearing glasses etc.) to correct your eyesight before use.</li> </ul>
3D Eyewear is turned off automatically	<ul style="list-style-type: none"> <li>• Check that there are no obstacles between the 3D IR TRANSMITTER and the 3D Eyewear or that the 3D Eyewear is placed inside the coverage area. If the 3D Eyewear stops receiving the infrared signal for about 5 minutes, the 3D Eyewear will be turned off automatically.</li> </ul>
There is something wrong with the 3D images	<ul style="list-style-type: none"> <li>• Switch “SWAPPED” and “NORMAL” under “LEFT/RIGHT SWAP” in “3D SETTINGS” (see page 37).</li> </ul>
Indicator lamp will not light when the 3D glasses are turned ON.	<ul style="list-style-type: none"> <li>• The battery may be running low or flat. Change the battery or charge the 3D glasses.</li> </ul>

## Table of images that can be seen for each 3D Picture Format and the source image format

If the picture appears to be abnormal, refer to the table below to choose the correct 3D picture format setting.

3D INPUT FORMAT Source image format	AUTO	SIDE BY SIDE	TOP AND BOTTOM	NATIVE
Side by side	 *1	 Normal*2		
Top and bottom	 *1		 Normal*2	
Normal format (2D)	 Normal			 Normal

\*1 When the source image is not recognized correctly

\*2 When “3D FUNCTION” is set to “ON”, the images will be displayed with 3D effect. When set to “OFF”, displayed without 3D effect.

• Depending on the player or contents, the image may be different from the above illustrations.



# On-Screen Menu Displays

## Remote Control

## Unit

### 1 Display the menu screen.

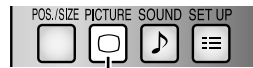

Press to select.  
(Example: PICTURE menu)

Press several times.

MENU  
Each time the MENU button is pressed, the menu screen will switch.

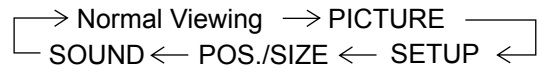

### 2 Select the item.

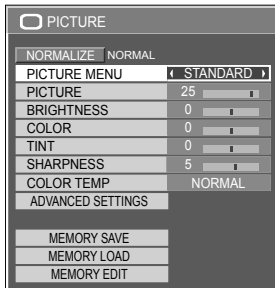

(Example: PICTURE menu)

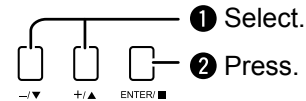
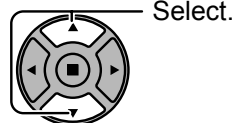

### 3 Set.

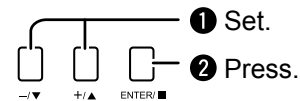
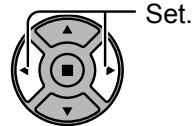

### 4 Exit the menu.



Press. <sub>R</sub>  
Press to return to the previous menu.

Press several times.  
MENU

## Menu display list

**Note:** Menu that cannot be adjusted is grayout. Adjustable menu changes depending on signal, input and menu setting.

### PICTURE menu

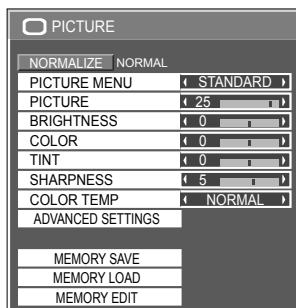

see page 29-33

### SETUP menu

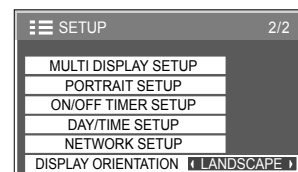
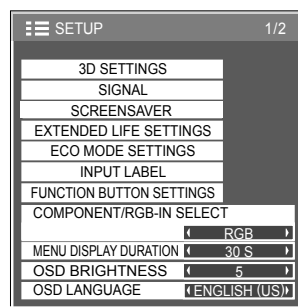

see page 35-54

### POS./SIZE menu

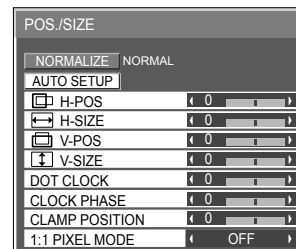

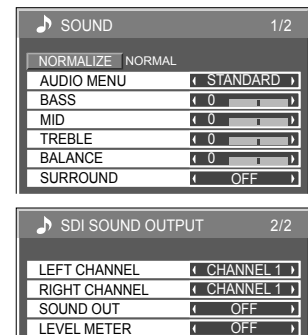

see page 26-28

### SOUND menu

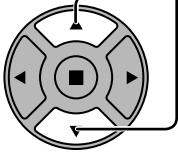
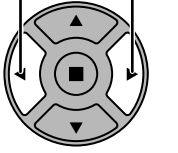

see page 34

# Adjusting POS./SIZE

- 1  Press to display the POS./SIZE menu.
- 2  Press to select the menu to adjust.
- 3  Press to adjust the menu.
- 4  Press to exit from adjust mode.

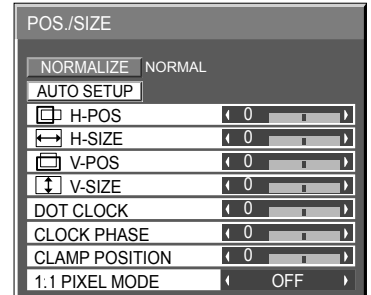

## Note:

Unadjustable items are grayed out.  
Adjustable items differ depending on the input signal and the display mode.

## Notes:

- Adjustment details are memorized separately for different input signal formats. (Adjustments for component signals are memorized for 525 (480) / 60i · 60p, 625 (575) / 50i · 50p, 1125 (1080) / 60i · 50i · 60p · 50p · 24p · 25p · 30p · 24sF, 1250 (1080) / 50i, 750 (720) / 60p · 50p each, and RGB/PC/Digital signals are memorized for each frequency.)
- If a “Cue” or “Rew” signal from a VCR or DVD player is received, the picture position will shift up or down. This picture position movement cannot be controlled by the POS./SIZE function.

## AUTO SETUP

When inputting a PC signal as an example, “H-POS/V-POS”, “H-SIZE/V-SIZE”, “DOT CLOCK” and “CLOCK PHASE” are automatically corrected.

This setting is enabled under the following conditions:

- When inputting an analog signal (Component/PC):  
This setting is enabled if “COMPONENT/RGB-IN SELECT” (see page 51) in SETUP menu is “RGB”.
- When inputting a digital signal (HDMI/DVI):  
A PC format signal enables this setting.  
When the signal is not PC format, this setting is enabled only if “OVER SCAN” (see page 27) is “OFF” or “1:1 PIXEL MODE” (see page 28) is “ON.” H-SIZE/V-SIZE is not automatically adjusted.

This setting will be invalid and will not work under the following conditions:

- When NETWORK input is selected.
- When VIDEO signal input
- During Multiple display, Portrait display or Digital Zoom.
- Aspect is set to “JUST”
- “Display size” in the Options menu (see page 56) is set to “On”

## Using Remote Control



When  on the remote control is pressed, “AUTO SETUP” will be executed.

When AUTO SETUP does not work, “INVALID” is displayed.

## Auto mode

When the “Auto Setup” is set to “Auto” in the Options menu (see page 57), automatic position adjustment starts:

- When the display power is turned ON.
- When the input signal is switched.

**Notes:**

- If the dot clock frequency of an analog signal is 162 MHz or higher, “DOT CLOCK” and “CLOCK PHASE” cannot be automatically corrected.
- When digital signal input, DOT CLOCK and CLOCK PHASE cannot be made.
- AUTO SETUP may not work when a cropped or dark image is input. In such case, switch to a bright image with borders and other objects are clearly shown, and then try auto setup again.
- Depending on the signal, out of alignment may occur after AUTO SETUP. Carry out fine tuning for the position/size as required.
- If AUTO SETUP cannot set properly for vertical frequency 60Hz XGA signal (1024×768@60Hz, 1280×768@60Hz, and 1366×768@60Hz), pre-selecting the individual signal in “XGA MODE” (see page 52) may results in correct AUTO SETUP.
- AUTO SETUP does not work well when a signal such as additional information is superimposed out of valid image period or intervals between synchronizing and image signals are short, or for image signal with tri-level synchronizing signal added.
- If AUTO SETUP cannot adjust correctly, select “NORMALIZE” once and press ACTION (■) then adjust POS./SIZE manually.

**H-POS**

Adjust the horizontal position.

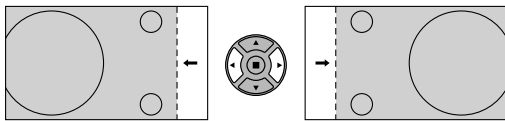

**V-POS**

Adjust the vertical position.

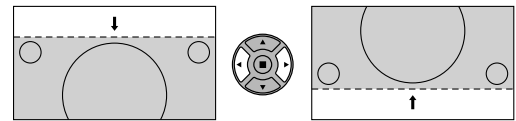

**H-SIZE**

Adjust the horizontal size.

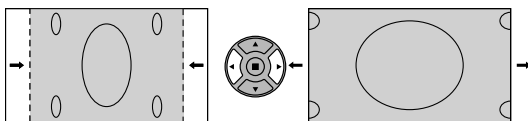

**V-SIZE**

Adjust the vertical size.

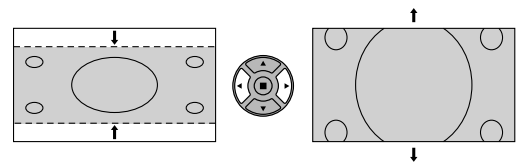

**DOT  
CLOCK**

**(During Component/PC input signal)**

Periodic striped pattern interference (noise) may occur when a striped pattern is displayed. If this happens, adjust so that any such noise is minimized.

**CLOCK  
PHASE**

**(During Component/PC input signal)**

Eliminate the flickering and distortion.

**OVER  
SCAN**

Turn image over scan ON/OFF.

Configurable signals are as follows:

525i, 525p, 625i, 625p, 750/60p, 750/50p (Component Video, RGB, DVI, SDI, HDMI)

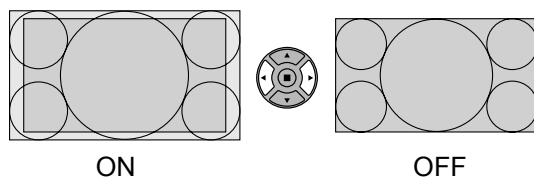

**Notes:**

- When “OFF” is set, “H-SIZE” and “V-SIZE” cannot be adjusted.
- When the “Display size” is set to “On” in the Options menu, this setting will be invalid. (see page 56)

# Adjusting POS./SIZE

## CLAMP POSITION (During Component/PC input signal)

Adjusts the clamp position when black parts of the image have no detail due to underexposure or are tinged with green.

### Optimum value for Clamp Position adjustment

When black parts have no detail due to underexposure (blackout)

→Value that causes least blackout is the optimum.

When black parts are tinged with green

→Value that cancels the greenishness without causing blackout is the optimum.

**1:1 PIXEL MODE** Adjusts the display size when 1125i, 1125p or 1250i signal is input.

### Notes:

- Select ON when you would like to replay 1920 × 1080 input signal.
- Applicable input signal;  
1125 (1080) / 50i · 60i · 24sF · 24p · 25p · 30p · 50p · 60p, 1250 (1080) / 50i
- Select OFF when flickering is shown around the image.
- H-SIZE and V-SIZE cannot be adjusted when ON is selected.

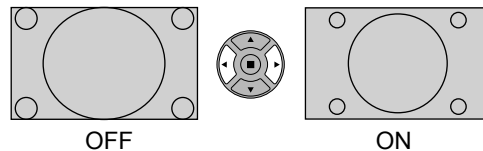

**1:1 PIXEL MODE (2k1k)** When the input signal is a 2k1k signal (2048×1080 / 24p, 2048×1080 / 24sF), the display size is adjusted as follows.

(For 2k1k signals)

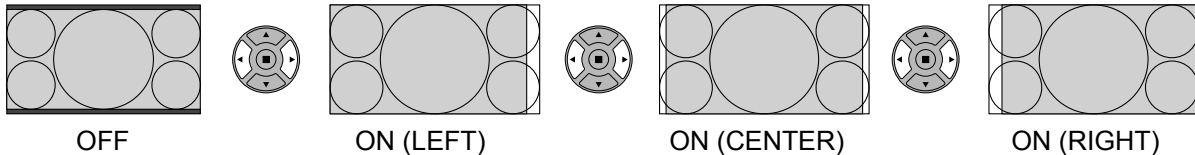

### Note:

2k1k signals can only be received when the Dual Link HD-SDI Terminal Board (TY-FB11DHD) is installed.

## Helpful Hint ( / **NORMALIZE** Normalization)

While the POS./SIZE display is active, if either the N button on the remote control is pressed at any time or the ACTION (■) button is pressed during "NORMALIZE", then all adjustment values are returned to the factory settings.

# PICTURE Adjustments

1  Press to display the PICTURE menu.

2 Select to adjust each item.

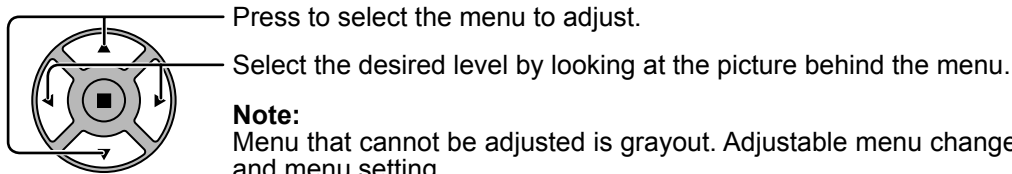

**Note:**

Menu that cannot be adjusted is grayout. Adjustable menu changes depending on signal, input and menu setting.

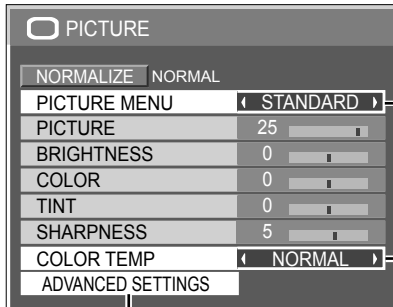

Press the left ◀ or right ▶ button to switch between modes.

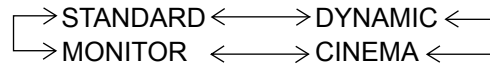

**STANDARD**

For viewing in standard (evening lighting) environments. This menu selects the normal levels of BRIGHTNESS and PICTURE.

**DYNAMIC**

For viewing in brighter environments. This menu selects higher than normal levels of BRIGHTNESS and PICTURE.

**CINEMA**

For use in viewing tone-focused pictures with brightness reduced.

**MONITOR**

For use when creating broadcast or movie content. With this picture, even if the overall average picture level (APL) changes, the brightness of areas with the same signal level does not change.

**Notes:**

- When "MONITOR" is selected in PICTURE MENU, the following menu items cannot be set.  
EXTENDED LIFE SETTINGS: PEAK LIMIT (see page 41)  
MULTI DISPLAY SETUP menu: VIDEO WALL UNIFORMITY (see page 48)  
PORTRAIT SETUP menu: VIDEO WALL UNIFORMITY (see page 50)
- If you would like to change the picture and color of the selected PICTURE menu to something else, adjust using the items in the PICTURE menu. (see next page)

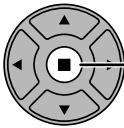

Press to enter Advanced Settings.

**ADVANCED SETTINGS**  
Enables fine picture adjustment at a professional level (see next page).

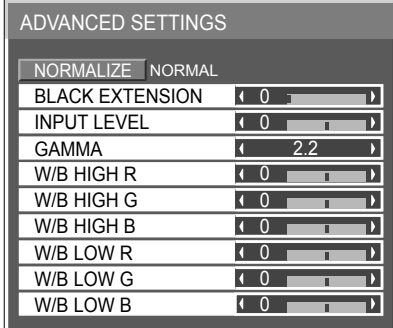

Press the left ◀ or right ▶ button to switch between modes.

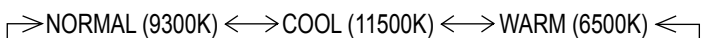

**Helpful Hint (  / **NORMALIZE** Normalization)**

While the "PICTURE" menu is displayed, if either the N button on the remote control is pressed at any time or the ACTION (■) button is pressed during "NORMALIZE", then all adjustment values are returned to the factory settings.

## PICTURE Adjustments

Item	Effect	Adjustments
PICTURE	Less       More	Adjusts the proper picture contrast.
BRIGHTNESS	Darker       Brighter	Adjusts for easier viewing of dark pictures such as night scenes and black hair.
COLOR	Less       More	Adjusts color saturation.
TINT	Reddish       Greenish	Adjusts for natural flesh tones.
SHARPNESS	Less       More	Adjusts picture sharpness.

### Notes:

- You can change the level of each function (PICTURE, BRIGHTNESS, COLOR, TINT, SHARPNESS) for each PICTURE MENU.
- The setting details for STANDARD, DYNAMIC, CINEMA and MONITOR respectively are memorized separately for each input terminal.
- In PICTURE, there is not a noticeable change even when contrast is increased with a bright picture or reduced with a dark picture.

## ADVANCED SETTINGS

Item	Effect	Details
BLACK EXTENSION	Less       More	Adjusts the dark shades of the image in gradation.
INPUT LEVEL	Less       More	Adjustment of parts which are extremely bright and hard to see.
GAMMA	Down       Up	2.0 $\longleftrightarrow$ 2.2 $\longleftrightarrow$ 2.4 $\longleftrightarrow$ 2.6
W/B HIGH R	Less       More	Adjusts the white balance for light red areas.
W/B HIGH G	Less       More	Adjusts the white balance for light green areas.
W/B HIGH B	Less       More	Adjusts the white balance for light blue areas.
W/B LOW R	Less       More	Adjusts the white balance for dark red areas.
W/B LOW G	Less       More	Adjusts the white balance for dark green areas.
W/B LOW B	Less       More	Adjusts the white balance for dark blue areas.

### Notes:

- Carry out "W/B" adjustment as follows.
  - Adjust the white balance of the bright sections using the "W/B HIGH R", "W/B HIGH G" and "W/B HIGH B" settings.
  - Adjust the white balance of the dark sections using the "W/B LOW R", "W/B LOW G" and "W/B LOW B" settings.
  - Repeat steps 1 and 2 to adjust.
 Steps 1 and 2 affect each other's settings, so repeat each step in turn to make the adjustment.
- The adjustment values are memorized separately for each input terminal.
- The adjustment range values should be used as an adjustment reference.

### Helpful Hint ( / **NORMALIZE** Normalization)

On the remote control unit, while the "ADVANCED SETTINGS" menu is displayed, if either the N button is pressed at any time or the ACTION () button is pressed during "NORMALIZE", then all adjustment values are returned to the factory settings.

# Picture Profiles

Up to 8 combinations of picture adjustment values (in the PICTURE menu and ADVANCED SETTINGS) can be stored in the display memory as profiles and applied as needed, for a convenient way to enjoy your preferred picture settings.

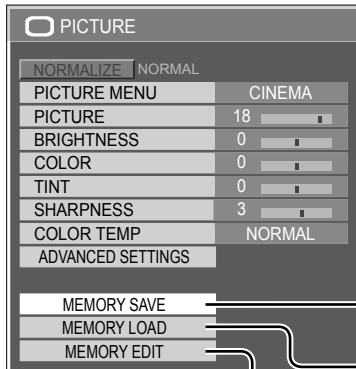

Save profiles (page 32)

Load profiles (page 33)

Edit profiles (page 33)

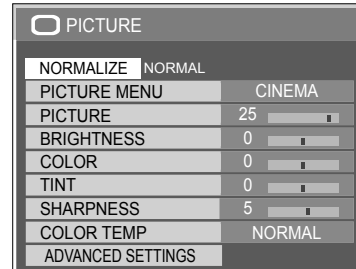

Save profiles

Save the picture adjustment values in the MEMORY1 profile

Edit the profile  
Delete or rename the profile

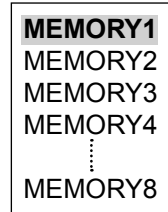
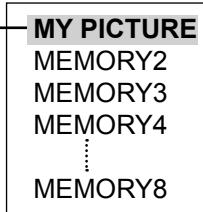

Load the profile

Apply the MEMORY1 profile

Original picture



Custom picture

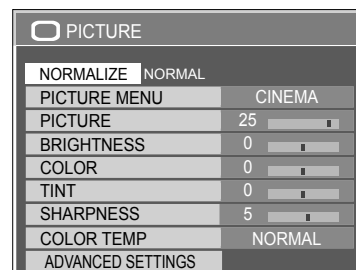
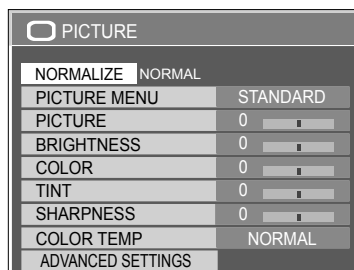

## Saving profiles

Follow these steps to save picture adjustment values as profiles.

**Note:**

When the settings are locked in “EXTENDED LIFE SETTINGS”, profiles cannot be saved.

**1** Specify the picture quality in the PICTURE menu and ADVANCED SETTINGS. (see page 29, 30)

**2** In the PICTURE menu, select “MEMORY SAVE”.



**3** Select a profile name for saving the picture adjustment values.



“\*” appears for a profile in which the picture adjustments have already been saved.

**4** Select “OK”.

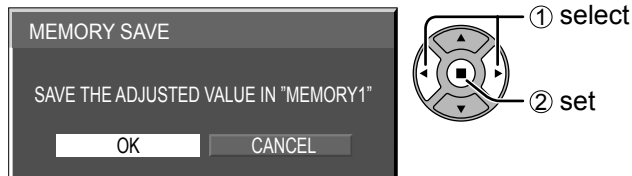

**5** Enter a name for the profile.

**[Entering profile names]**

Profile names can be up to 40 characters.

To enter text, select characters in the on-screen keyboard.

Edit the default profile name in the text box as desired.

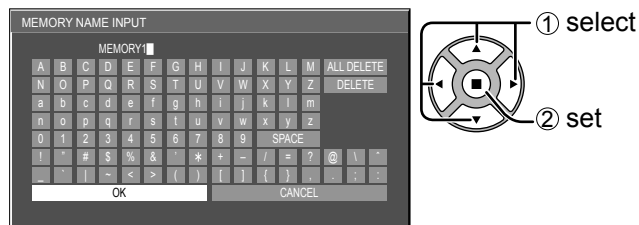

**Example: Specifying “MY PICTURE”**

① Select “ALL DELETE”.



All text is deleted.

To delete individual characters, select “DELETE”.

② Select “M”.



Repeat this process to enter the next character.

③ Select “Y”.



④ Select “SPACE”.



**6** When you finished entering the profile name, select “OK”.

To cancel saving the profile, select “CANCEL”.

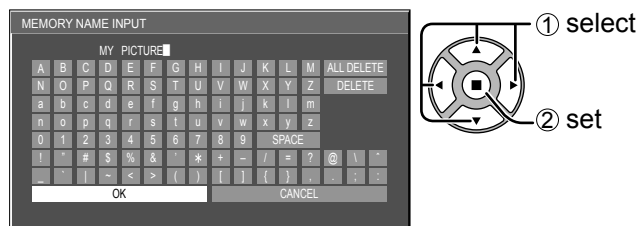



# Loading profiles

Load profiles and apply the picture adjustment values to the display as follows.

**Notes:**

- Loaded profiles are stored in memory according to the selected input interface. (see page 18)
- When the settings are locked in “EXTENDED LIFE SETTINGS”, profiles cannot be loaded.

**1** In the PICTURE menu, select “MEMORY LOAD”.

**2** Select the profile to load.

When profile is being loaded, profile name is displayed.

# Editing profiles

Delete or rename profiles as follows.

**<Deleting profiles>**

**1** In the PICTURE menu, select “MEMORY EDIT”.

**2** Select “MEMORY DELETE”.

**3** Select the profile to delete.  
To delete all profiles, select “ALL DELETE”.

**4** Select “OK”.

**<Renaming profiles>**

**1** In the PICTURE menu, select “MEMORY EDIT”.

**2** Select “MEMORY NAME CHANGE”.

**3** Select the profile to rename.

**4** Enter a name for the profile.  
Entering profile names → page 32

**5** When you finished entering the profile name, select “OK”.  
To cancel renaming the profile, select “CANCEL”.

# SOUND Adjustment

**1**  Press to display the SOUND menu.

**2** Select to adjust each item.

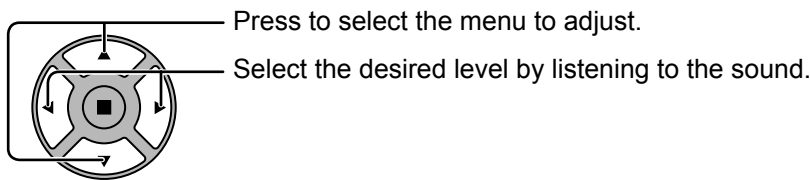

**3**  Press to exit from adjust mode.

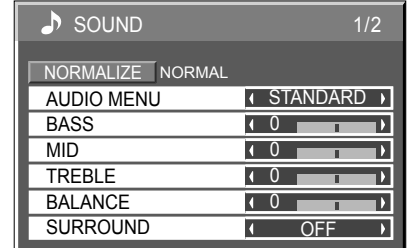

Item	Details
<b>AUDIO MENU</b>	<b>STANDARD:</b> Emits the original sound. <b>DYNAMIC:</b> Accentuates sharp sound. <b>CLEAR:</b> Attenuates human voice.
<b>BASS</b>	Adjusts low pitch sounds.
<b>MID</b>	Adjusts normal sounds.
<b>TREBLE</b>	Adjusts high pitch sound.
<b>BALANCE</b>	Adjusts left and right volumes.
<b>SURROUND</b>	Select ON or OFF.

**Note:** BASS, MID, TREBLE and SURROUND settings are memorized separately for each AUDIO MENU.

## Helpful Hint ( / **NORMALIZE** Normalization)

While the "SOUND" menu is displayed, if either the N button on the remote control is pressed at any time or the ACTION () button is pressed during "NORMALIZE", then all adjustment values are returned to the factory settings.

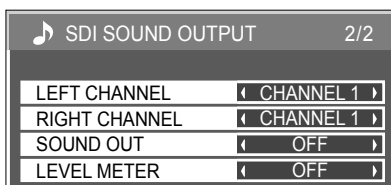

# SDI SOUND OUTPUT

This menu is available only when selecting a slot that any of the following terminal boards is installed:  
HD-SDI Terminal Board with audio (TY-FB10HD) or Dual Link HD-SDI Terminal Board (TY-FB11DHD)

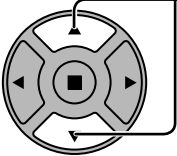
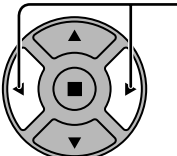

Item	Details
<b>LEFT CHANNEL</b>	<b>CHANNEL 1 to CHANNEL 16</b> Selects left audio channel.
<b>RIGHT CHANNEL</b>	<b>CHANNEL 1 to CHANNEL 16</b> Selects right audio channel.
<b>SOUND OUT</b>	<b>ON ↔ OFF</b> <b>ON:</b> Enables audio output. <b>OFF:</b> Disables audio output.
<b>LEVEL METER</b>	<b>OFF ↔ 1-8CH ↔ 9-16CH</b> Sets audio channels to show in the audio level meter. 8 channels are displayed in the audio level meter; 4 channels each on both right and left sides of the display. <b>OFF:</b> Hides the audio level meter. <b>1-8CH:</b> Displays the audio level meter (1-8ch) <b>9-16CH:</b> Displays the audio level meter (9-16ch)

# SETUP menu

- 1  Press to display the SETUP menu.
- 2  Press to select the menu to adjust.
- 3  Press to adjust the menu.
- 4  Press to exit from adjust mode.

SETUP 1/2	
3D SETTINGS	
SIGNAL	
SCREENSAVER	
EXTENDED LIFE SETTINGS	
ECO MODE SETTINGS	
INPUT LABEL	
FUNCTION BUTTON SETTINGS	
COMPONENT/RGB-IN SELECT	
	RGB
NO ACTIVITY POWER OFF	DISABLE
MENU DISPLAY DURATION	30 S
OSD BRIGHTNESS	5
OSD LANGUAGE	ENGLISH (US)

Press  to return to the previous menu.

## SETUP menu screen

SETUP 1/2		
3D SETTINGS		Page 37
SIGNAL		Page 52
SCREENSAVER		Page 38
EXTENDED LIFE SETTINGS		Page 40
ECO MODE SETTINGS		Page 43
INPUT LABEL		Page 44
FUNCTION BUTTON SETTINGS		Page 45
COMPONENT/RGB-IN SELECT		
	RGB	Page 51
NO ACTIVITY POWER OFF	DISABLE	Page 46
MENU DISPLAY DURATION	30 S	Page 46
OSD BRIGHTNESS	5	Page 46
OSD LANGUAGE	ENGLISH (US)	Page 46

SETUP 2/2		
MULTI DISPLAY SETUP		Page 47
PORTRAIT SETUP		Page 49
ON/OFF TIMER SETUP		Page 36
DAY/TIME SETUP		Page 36
NETWORK SETUP		
DISPLAY ORIENTATION	LANDSCAPE	Page 46

## NETWORK SETUP

Set this to connect the Display to a computer via a network. For details of PjLink and Network, refer to "Operating Instructions, Network Operations".

# DAY/TIME SETUP / ON/OFF TIMER SETUP

The timer can switch the Plasma Display ON or OFF.

Before attempting Timer Set, confirm the TIME and adjust if necessary. Then set POWER ON TIME / POWER OFF TIME.

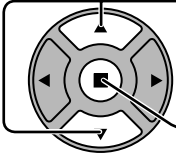
- 1  Press to display the SETUP menu.
- 2  Press to select ON/OFF TIMER SETUP or DAY/TIME SETUP.  
Press to display the ON/OFF TIMER SETUP screen or DAY/TIME SETUP screen.

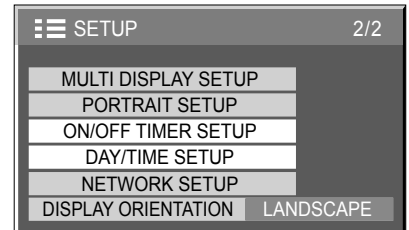

## DAY/TIME SETUP

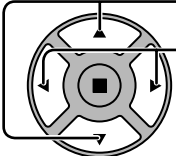
- 1  Press to select DAY or TIME.  
Press to set up DAY or TIME.  
▶ button: Forward  
◀ button: Back

**Notes:**

- Pressing “◀” or “▶” button once changes TIME 1 minute.
- Pressing “◀” or “▶” button continuously changes TIME by 15 minutes.

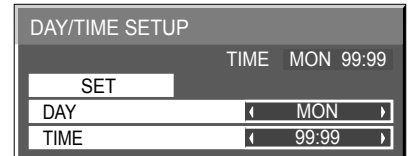

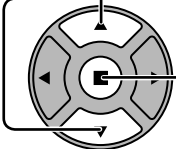
- 2  Press to select SET.  
Press to store DAY/TIME SETUP.

**Notes:**

- SET cannot be selected unless TIME is set.
- Unless setting the present time other than “99:99”, “DAY” and “TIME” cannot be set.
- The settings of “DAY” and “TIME” are reset when leaving the display turned off for about 7 days for the following reasons:  
Pressing ⏻/| switch of the unit to turn off the display.  
Disconnecting the AC cord.  
Interruption of power supply.

## ON/OFF TIMER SETUP

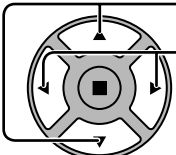
- 1  Press to select POWER ON TIME / POWER OFF TIME.  
Press to set up POWER ON TIME / POWER OFF TIME.  
▶ button: Forward  
◀ button: Back

**Notes:**

- Pressing “◀” or “▶” button once changes POWER ON TIME / POWER OFF TIME 1 minute.
- Pressing “◀” or “▶” button continuously changes POWER ON TIME / POWER OFF TIME by 15 minutes.

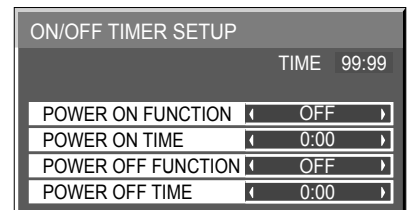

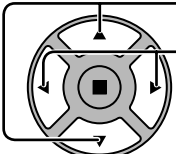
- 2  Press to select POWER ON FUNCTION / POWER OFF FUNCTION.  
Press to select ON.
- Note:**  
Timer function will not work unless “TIME” is set.

# 3D SETTINGS

To view the 3D images, please adjust and setup the 3D settings.

**Note:**

Set these settings for each input terminals.

Select "3D SETTINGS" in "SETUP" menu and press  button.



## 3D SETTINGS sub-menu screen

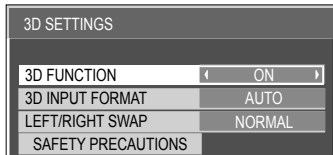

- **3D FUNCTION**

**ON** ↔ **OFF**

**ON:** To view the 3D images, please set it to "ON". You can see 3D images for 3D image signal and 2D images for 2D image signal.

**OFF:** You can see 2D images instead of 3D images.

When set to "ON", "3D" is displayed during 3D images.

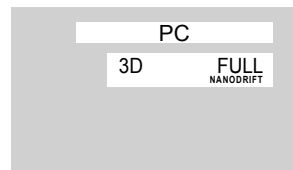

- **3D INPUT FORMAT**

3D images method is set.

**AUTO:** 3D images are automatically displayed according to the signal.

**SIDE BY SIDE/TOP AND BOTTOM:** One of the formats of the 3D standard. Select these formats as necessary.

**NATIVE:** Displays the input signal as it is. Use to identify the format type of the input signal.

- **LEFT/RIGHT SWAP**

**NORMAL** ↔ **SWAPPED**

This function calibrates the timing to switch the right and left images as well as the timing to switch the shutter of right and left 3D Eyewear.

Selects "SWAPPED" if you feel that the sense of depth is unusual.

- **SAFETY PRECAUTIONS**

Displays the precautions for viewing 3D images.

# SCREENSAVER (For preventing image retention)

Do not display a still picture, especially in 4:3 mode, for any length of time.  
If the display must remain on, a SCREENSAVER should be used.

**1** Select "SCREENSAVER" in "SETUP" menu and press  button.

## **2** FUNCTION selection

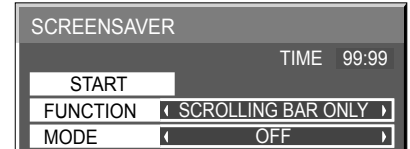
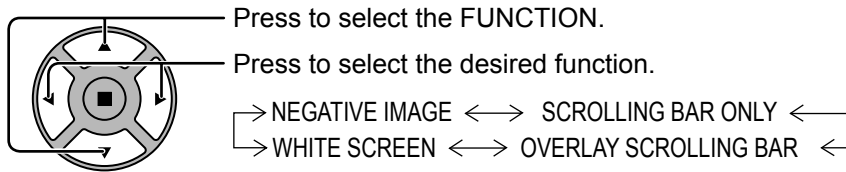

- NEGATIVE IMAGE : A negative image will be displayed on the screen.
- SCROLLING BAR ONLY : A white bar will scroll from left to right. The image won't be displayed.
- OVERLAY SCROLLING BAR : The brightness of the image will be decreased and a white bar will scroll on it.
- WHITE SCREEN : The whole screen will be white.

## **3** MODE selection

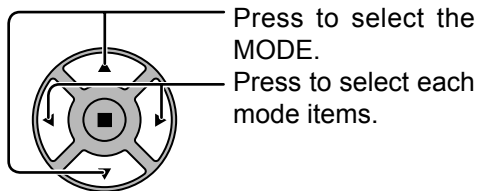

- OFF
- ↕
- INTERVAL : Operates when SHOW DURATION and SAVER DURATION are set up and those times arrive.
- ↕
- TIME OF DAY : Operates when START TIME and FINISH TIME are set up and those times arrive.
- ↕
- STANDBY AFTER SCR SAVER: Operates while SCREENSAVER DURATION, and display enters standby mode.
- ↕
- ON : Operates when START is selected and the ACTION  button is pressed.

## **4** START setting

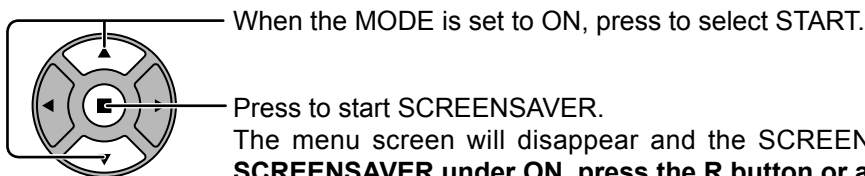

The menu screen will disappear and the SCREENSAVER will be activated. **To stop the SCREENSAVER under ON, press the R button or any buttons on the main unit.**

**Note:** When the display is turned off, the SCREENSAVER will be deactivated.

## Setup of SCREENSAVER Time

After selecting TIME OF DAY, INTERVAL or STANDBY AFTER SCR SAVER, the relevant Time Setup will become available for selection and the Operating Time may be set. (Time cannot be set when "MODE" is "ON" or "OFF".)

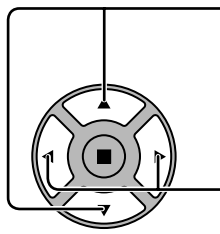

Press to select START TIME / FINISH TIME (when TIME OF DAY is selected).

Press to select SHOW DURATION / SAVER DURATION (when INTERVAL is selected).

Press to select SCREENSAVER DURATION (when STANDBY AFTER SCR SAVER is selected).

Press to setup.

▶ button: Forward

◀ button: Back

### Notes:

- Pressing "◀" or "▶" button once changes the Time 1 minute.  
[However, switching occurs every 15 minutes when Periodic Time is selected.]
- Pressing "◀" or "▶" button continuously changes the Time by 15 minutes.
- "SCREENSAVER DURATION" of the "STANDBY AFTER SCR SAVER" can be set from 0:00 to 23:59. When this is set to "0:00", "STANDBY AFTER SCR SAVER" will not be activated.

**Note:** Timer function will not work unless "TIME" is set.

SCREENSAVER		TIME	15:00
START			
FUNCTION	SCROLLING BAR ONLY		
MODE	TIME OF DAY		
START TIME	◀	6:15	▶
FINISH TIME	◀	12:30	▶

SCREENSAVER		TIME	15:00
START			
FUNCTION	SCROLLING BAR ONLY		
MODE	INTERVAL		
SHOW DURATION	◀	12:00	▶
SAVER DURATION	◀	3:00	▶

SCREENSAVER		TIME	15:00
START			
FUNCTION	SCROLLING BAR ONLY		
MODE	STANDBY AFTER SCR SAVER		
SCREENSAVER DURATION	◀	6:15	▶

# Reduces screen image retention

## EXTENDED LIFE SETTINGS

The following settings are setup to reduce image retention:

Select "EXTENDED LIFE SETTINGS" in "SETUP" menu and press  button.

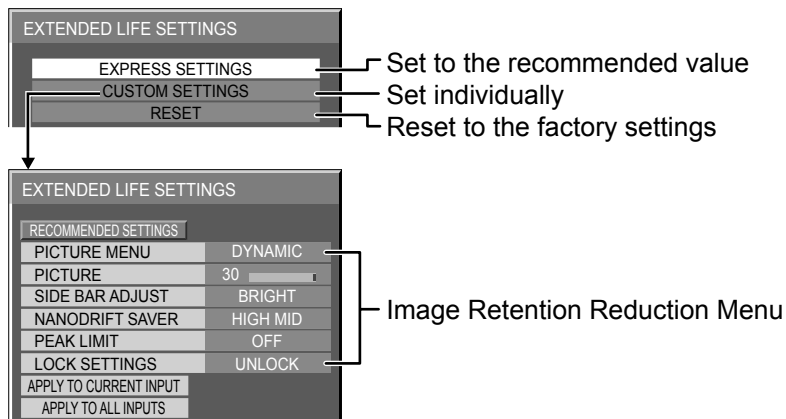

### Image Retention Reduction Menu

"EXTENDED LIFE SETTINGS" enables you to set the following 5 menus (Image Retention Reduction Menu) as recommended values or set them individually.

#### PICTURE MENU

##### PICTURE

"PICTURE MENU" and "PICTURE" are same as "PICTURE" menu items (see page 29). The settings of this menu will be reflected to the "PICTURE" menu.

#### SIDE BAR ADJUST

Do not display a picture in 4:3 mode for an extended period, as this can cause an image retention to remain on the side bars on either side of the display field.

To reduce the risk of such an image retention, illuminate the side bars.

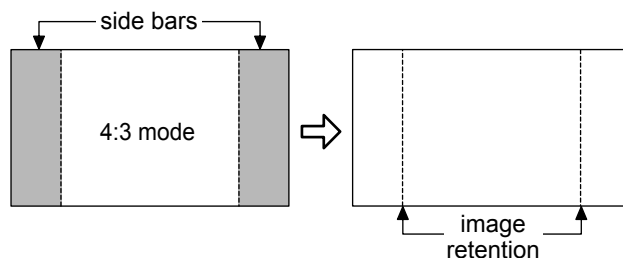

This function may be applicable to the non-picture area.

**OFF:** Darken both ends.

**DARK:** Make it dark gray.

**MID:** Make it gray.

**BRIGHT:** Make it light gray.

#### Notes:

- To reduce the occurrence of image retention, set the SIDE BAR ADJUST to BRIGHT.
- The side bar may flash (alternate black/white) depending on the picture being shown on the screen. Using Cinema mode will reduce such flashing.



## NANODRIFT SAVER

Moves the display position of the screen slightly to reduce image retention on the display panel.

**LOW-HIGH:** NANODRIFT SAVER operates. The display position of the screen moves at set time intervals. You can set the screen movement range. Some of the screen may appear to be missing as a result of this operation. If you change the value, a mask is displayed in the range where the picture is missing as a result of position movement.



When “NANODRIFT” Image Retention Reduction is operating, “NANODRIFT” is displayed.

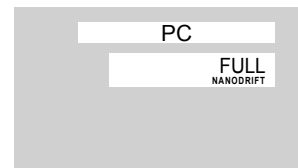

### Note:

This function does not work in the following cases.

When “MULTI DISPLAY SETUP” is set to “ON”

When “PORTRAIT SETUP” is set to “ON”

When in digital zoom mode

## PEAK LIMIT

**ON:** Suppresses image contrast (peak brightness).

**Note:** When a still picture is viewed for an extended time, the screen may become slightly darker. (see page 63)

## EXPRESS SETTINGS

Set the “Image Retention Reduction” menu to the recommended settings.

All menus will be locked.

PICTURE MENU: STANDARD

PICTURE: Recommended setting for each model

SIDE BAR ADJUST: BRIGHT

NANODRIFT SAVER: HIGH MID

PEAK LIMIT: ON

### 1 Select “EXPRESS SETTINGS”.

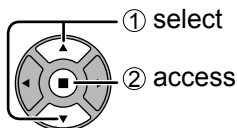
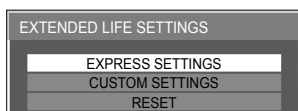

### 2 Select the input to apply the settings.

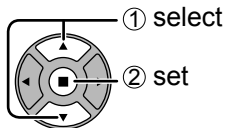
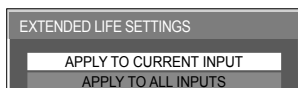

### 3 Select “YES”.

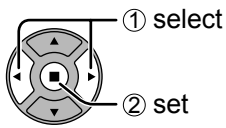
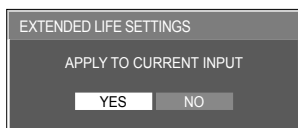

# Reduces screen image retention

## CUSTOM SETTINGS

Set the individual “Image Retention Reduction” menu.

**1** Select “CUSTOM SETTINGS”.

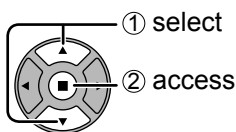
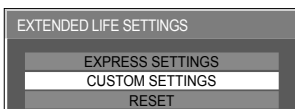

**2** To set each menu to the recommended setting:  
Select “RECOMMENDED SETTINGS”.

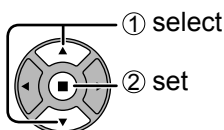
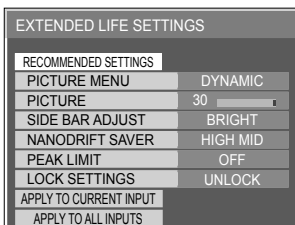

Each menu will be set as same as the “EXPRESS SETTINGS”.

**3** Set each menu.

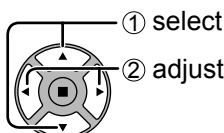
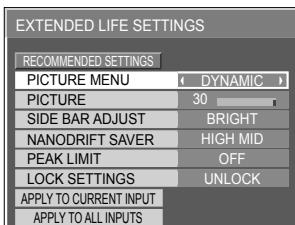

**4** To lock each menu setting:  
Set the “LOCK SETTINGS” to “LOCK”.

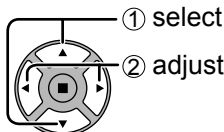
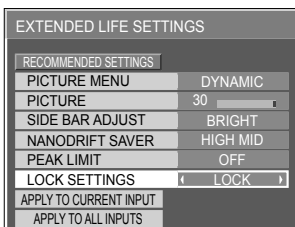

When a menu is locked, it is grayed out and cannot be set. “PICTURE MENU” and “PICTURE” will no longer be able to set in the “PICTURE” menu, and they are labeled with icon to indicate their locked status. Also, “NORMALIZE”, “MEMORY SAVE” and “MEMORY LOAD” are not available.

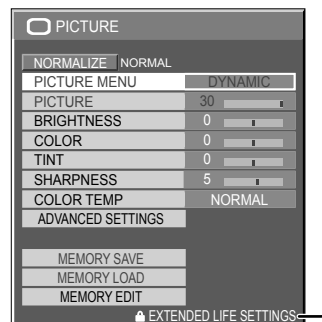

**5** Select the input to apply the settings.

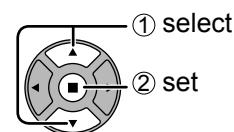
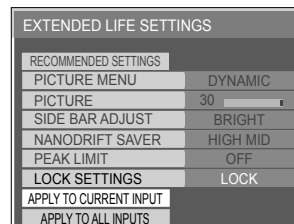

**6** Select “YES”.

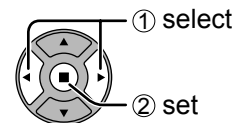
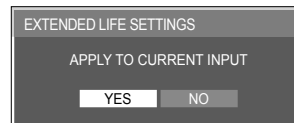

## RESET

Reset the “Image Retention Reduction” menu to the factory settings. Each menu will be unlocked.

**1** Select “RESET”.

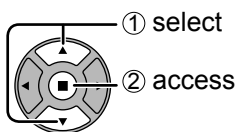
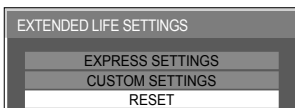

**2** Select the input to reset the settings.

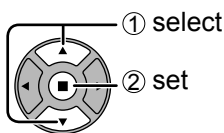
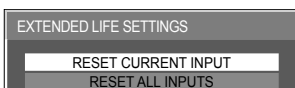

**3** Select “YES”.

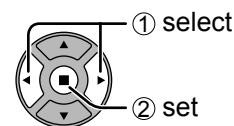
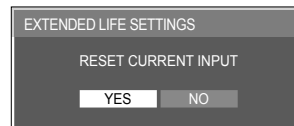

# ECO MODE SETTINGS

Select "ECO MODE SETTINGS" in "SETUP" menu and press  button.



ECO MODE SETTINGS	
ECO MODE	CUSTOM
POWER SAVE	OFF
STANDBY SAVE	ON
PC POWER MANAGEMENT	OFF
DVI-D POWER MANAGEMENT	OFF
NO SIGNAL POWER OFF	DISABLE

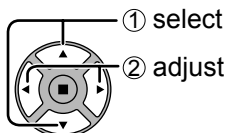

## ECO MODE

**CUSTOM:** The menu of power consumption reduction is individually set.

**ON:** The following fixed values are set to the menu of power consumption reduction. Individual setting is not available.

POWER SAVE: SENSOR                      DVI-D POWER MANAGEMENT: ON  
STANDBY SAVE: ON                         NO SIGNAL POWER OFF: ENABLE  
PC POWER MANAGEMENT: ON

### Using Remote Control

When  is pressed, the "ECO MODE" setting changes.

ECO MODE    ON

## Custom settings

The menu of the power consumption reduction is individually set. This setting is enabled when "ECO MODE" is set to "CUSTOM".

### POWER SAVE

When this function is turned ON, luminous level of the Plasma Display is suppressed, so power consumption is reduced.

**SENSOR:** The luminous level of the Plasma Display is automatically adjusted according to the viewing environment.

### STANDBY SAVE

When this function is turned ON, power consumption of the microcomputer is reduced during power supply standby (see page 16, 19, 20), so standby power of the set is reduced.

### PC POWER MANAGEMENT

When this function is set to ON, it operates under the following conditions to turn the power on or off automatically.

When no pictures (HD/VD sync signals) are detected for 30 or so seconds during PC signal input:

→ Power is turned off (standby); the power indicator lights up orange.

When pictures (HD/VD sync signals) are subsequently detected:

→ Power is turned on; the power indicator lights up green.

#### Notes:

- This function operates only during PC signal input.
- This function is effective when "SYNC" is set to "AUTO", "COMPONENT / RGB-IN SELECT" is set to "RGB" and during normal viewing.

### DVI-D POWER MANAGEMENT

When this function is set to ON, it operates under the following conditions to turn the power on or off automatically.

When no pictures (sync signal) are detected for 30 or so seconds during DVI signal input:

→ Power is turned off (standby); the power indicator lights up orange.

When pictures (sync signal) are subsequently detected:

→ Power is turned on; the power indicator lights up green.

#### Notes:

- This function operates only during DVI signal input.
- This function is invalid during input from DVI-D Terminal Board (TY-FB11DD).
- Depending on the type of terminal board equipped, this function may be invalid.

### NO SIGNAL POWER OFF

Equipment power supply is turned OFF when there is no signal.

When this is set to "ENABLE", the power supply of the unit goes Off 10 minutes after the input signals stop.

# Customizing the Input labels

This function can change the label of the Input signal to be displayed. (see page 18)

Select "INPUT LABEL" in "SETUP" menu and press  button.

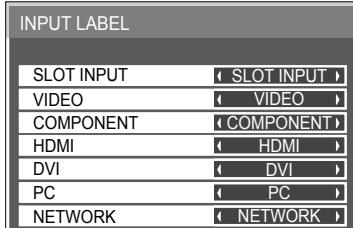

Image input	Input label
[SLOT INPUT]*1	SLOT INPUT / DVD1 / DVD2 / DVD3 / DVD4 / Blu-ray1 / Blu-ray2 / Blu-ray3 / Blu-ray4 / CATV / VCR / STB / (SKIP)
[VIDEO]	VIDEO / DVD1 / DVD2 / DVD3 / DVD4 / Blu-ray1 / Blu-ray2 / Blu-ray3 / Blu-ray4 / CATV / VCR / STB / (SKIP)
[COMPONENT]*2	COMPONENT / DVD1 / DVD2 / DVD3 / DVD4 / Blu-ray1 / Blu-ray2 / Blu-ray3 / Blu-ray4 / CATV / VCR / STB / (SKIP)
[HDMI]	HDMI / DVD1 / DVD2 / DVD3 / DVD4 / Blu-ray1 / Blu-ray2 / Blu-ray3 / Blu-ray4 / CATV / VCR / STB / (SKIP)
[DVI]	DVI / DVD1 / DVD2 / DVD3 / DVD4 / Blu-ray1 / Blu-ray2 / Blu-ray3 / Blu-ray4 / CATV / VCR / STB / (SKIP)
[PC]	PC / DVD1 / DVD2 / DVD3 / DVD4 / Blu-ray1 / Blu-ray2 / Blu-ray3 / Blu-ray4 / CATV / VCR / STB / (SKIP)
[NETWORK]	NETWORK / (SKIP)

(SKIP) : The INPUT button press will skip its input.

\*1 "SLOT INPUT" is displayed when a Terminal Board is installed.

\*2 "COMPONENT" may be displayed as "RGB" depending on the setting of "COMPONENT/RGB-IN SELECT".  
(see page 51)

## When a Terminal Board with dual input terminals is installed

"SLOT INPUT" is displayed as "SLOT INPUT A" and "SLOT INPUT B" and independent settings are available.



[SLOT INPUT A]	SLOT INPUT A / DVD1 / DVD2 / DVD3 / DVD4 / Blu-ray1 / Blu-ray2 / Blu-ray3 / Blu-ray4 / CATV / VCR / STB / (SKIP)
[SLOT INPUT B]	SLOT INPUT B / DVD1 / DVD2 / DVD3 / DVD4 / Blu-ray1 / Blu-ray2 / Blu-ray3 / Blu-ray4 / CATV / VCR / STB / (SKIP)

## When a Terminal Board with fixed display (such as Tuner Board) is installed

Only fixed display and (SKIP) are available as Input label of "SLOT INPUT".

[SLOT INPUT] fixed display / (SKIP)

# FUNCTION BUTTON SETTINGS

Set the functions that operates when   is pressed.

Select "FUNCTION BUTTON SETTINGS" in "SETUP" menu and press  button.

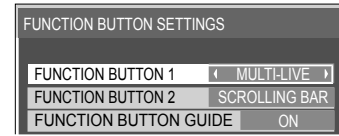

## • FUNCTION BUTTON 1, FUNCTION BUTTON 2

The following functions are set to the FUNCTION button.

### Note:

Factory settings are as follows.

FUNCTION1 button: MULTI-LIVE

FUNCTION2 button: SCROLLING BAR

## ECO MODE SETTINGS / 3D SETTINGS / SIGNAL / ON/OFF TIMER SETUP

Menu is displayed. (Example: ECO MODE SETTINGS)

FUNCTION  
 

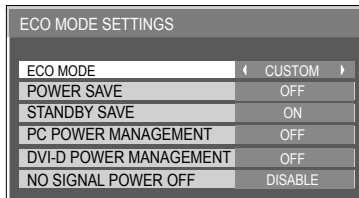

Pressing the FUNCTION button clears the menu.



## SCROLLING BAR

Activates the SCROLLING BAR ONLY screensaver. After 15 minutes, the display enters standby mode.



To exit this mode, press any button.

## INPUT (SLOT)\* – INPUT (NETWORK)

Simply press   to select the input.

\* "INPUT (SLOT)" is displayed when an optional Terminal Board is installed.

When a Terminal Board with dual input terminals is installed, "INPUT (SLOT A)" and "INPUT (SLOT B)" are displayed.

## NETWORK SETUP

"NETWORK SETUP" menu is displayed.

## COMPUTER SEARCH

The list of connectable computers on the network is displayed.

## MULTI-LIVE

Switch to the MULTI-LIVE mode when using the "Wireless Manager mobile edition 5.5".

## AV MUTE

Mutes the audio and video. To exit this mode, press any button.

## • FUNCTION BUTTON GUIDE

The function display setting for the FUNCTION button is configured.

ON: Press the FUNCTION button to display the function list of the button.

OFF: The function list is not displayed.

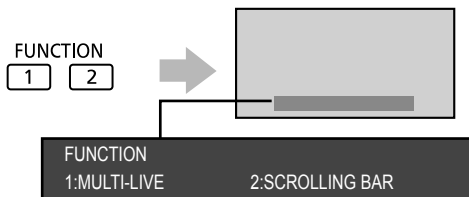

The operation starts.

# NO ACTIVITY POWER OFF

## DISABLE ↔ ENABLE

When this function is set to “ENABLE”, the power is turned off (standby) automatically when there is no operation of the Plasma Display for 4 hours.

Starting from 3 minutes before the turn off, the remaining time will be displayed.



When the power is turned off due to this function, a message “LAST TURN OFF DUE TO 'NO ACTIVITY POWER OFF'.” is displayed next time the power is turned on.

### Note:

During the screensaver is running, this function is disabled.

# MENU DISPLAY DURATION / OSD BRIGHTNESS

Set the display time and brightness of the on-screen menu display.

**MENU DISPLAY DURATION: 5 S – 30 S**

**OSD BRIGHTNESS: 1 – 5**

# OSD LANGUAGE

Select your preferred language.

### ■ Selectable languages

English(UK)

Deutsch

Français

Italiano

Español

ENGLISH(US)

中文 (Chinese)

日本語 (Japanese)

Русский (Russian)

# DISPLAY ORIENTATION

Sets the fan control, panel drive control, and the display style of on-screen menu for vertical installation.



**LANDSCAPE**

Fan control and panel drive control for horizontal installation.



**PORTRAIT**

Fan control and panel drive control for vertical installation. On-screen menu will be rotated 90 degrees counterclockwise to be suitable for the setting.

### Notes:

- Turn up the power switch for the upward direction when you set Display vertically.
- When you change this setting, fan control and panel drive control will be switched as the power is turned on next time.

# SETUP for MULTI DISPLAY

By lining up Plasma Displays in groups, for example, as illustrated below, an enlarged picture may be displayed across all screens. For this mode of operation, each plasma display has to be set up with a Display number to determine its location.

**Note:**

During Multi display, the 3D images are displayed as 2D images.

(Example)

group of 4 (2 × 2)    group of 9 (3 × 3)    group of 16 (4 × 4)    group of 25 (5 × 5)



## How to setup MULTI DISPLAY

1 Select "MULTI DISPLAY SETUP" in "SETUP" menu and press button.

2 Press to select the MULTI DISPLAY SETUP.  
Press to select "ON" or "OFF".

MULTI DISPLAY SETUP	
MULTI DISPLAY SETUP	OFF
HORIZONTAL SCALE	× 2
VERTICAL SCALE	× 2
SEAM HIDES VIDEO	OFF
LOCATION	A1
VIDEO WALL UNIFORMITY	OFF

Item	Details																																																									
<b>MULTI DISPLAY SETUP</b>	Select "ON" or "OFF". <b>Note:</b> If you set MULTI DISPLAY SETUP to ON, PORTRAIT SETUP will be unavailable.																																																									
<b>HORIZONTAL SCALE</b>	Select "× 1", "× 2", "× 3", "× 4", "× 5".																																																									
<b>VERTICAL SCALE</b>	Select "× 1", "× 2", "× 3", "× 4", "× 5".																																																									
<b>SEAM HIDES VIDEO</b>	Select "ON" or "OFF". <div style="display: flex; justify-content: space-around; align-items: flex-start;"> <div style="text-align: center;"> <p>To hide joints between displays.</p> <p>Example</p> <p>Suitable for moving image display.</p> <p>ON</p> </div> <div style="text-align: center;"> <p>To show joints between displays.</p> <p>Example</p> <p>Suitable for still image display.</p> <p>OFF</p> </div> </div>																																																									
<b>LOCATION</b>	Select the required arrangement number. (A1-E5 : Refer to the following) <b>Display Number locations for each arrangement.</b> <b>(Examples)</b> <div style="display: flex; justify-content: space-around; align-items: flex-start;"> <div style="text-align: center;"> <p>( 2 × 1 )</p> <table border="1" style="margin: 0 auto;"> <tr><td>A1</td><td>A2</td></tr> </table> </div> <div style="text-align: center;"> <p>( 2 × 3 )</p> <table border="1" style="margin: 0 auto;"> <tr><td>A1</td><td>A2</td></tr> <tr><td>B1</td><td>B2</td></tr> <tr><td>C1</td><td>C2</td></tr> </table> </div> <div style="text-align: center;"> <p>( 4 × 2 )</p> <table border="1" style="margin: 0 auto;"> <tr><td>A1</td><td>A2</td><td>A3</td><td>A4</td></tr> <tr><td>B1</td><td>B2</td><td>B3</td><td>B4</td></tr> </table> </div> <div style="text-align: center;"> <p>( 4 × 4 )</p> <table border="1" style="margin: 0 auto;"> <tr><td>A1</td><td>A2</td><td>A3</td><td>A4</td></tr> <tr><td>B1</td><td>B2</td><td>B3</td><td>B4</td></tr> <tr><td>C1</td><td>C2</td><td>C3</td><td>C4</td></tr> <tr><td>D1</td><td>D2</td><td>D3</td><td>D4</td></tr> </table> </div> <div style="text-align: center;"> <p>( 5 × 5 )</p> <table border="1" style="margin: 0 auto;"> <tr><td>A1</td><td>A2</td><td>A3</td><td>A4</td><td>A5</td></tr> <tr><td>B1</td><td>B2</td><td>B3</td><td>B4</td><td>B5</td></tr> <tr><td>C1</td><td>C2</td><td>C3</td><td>C4</td><td>C5</td></tr> <tr><td>D1</td><td>D2</td><td>D3</td><td>D4</td><td>D5</td></tr> <tr><td>E1</td><td>E2</td><td>E3</td><td>E4</td><td>E5</td></tr> </table> </div> </div>	A1	A2	A1	A2	B1	B2	C1	C2	A1	A2	A3	A4	B1	B2	B3	B4	A1	A2	A3	A4	B1	B2	B3	B4	C1	C2	C3	C4	D1	D2	D3	D4	A1	A2	A3	A4	A5	B1	B2	B3	B4	B5	C1	C2	C3	C4	C5	D1	D2	D3	D4	D5	E1	E2	E3	E4	E5
A1	A2																																																									
A1	A2																																																									
B1	B2																																																									
C1	C2																																																									
A1	A2	A3	A4																																																							
B1	B2	B3	B4																																																							
A1	A2	A3	A4																																																							
B1	B2	B3	B4																																																							
C1	C2	C3	C4																																																							
D1	D2	D3	D4																																																							
A1	A2	A3	A4	A5																																																						
B1	B2	B3	B4	B5																																																						
C1	C2	C3	C4	C5																																																						
D1	D2	D3	D4	D5																																																						
E1	E2	E3	E4	E5																																																						

# SETUP for MULTI DISPLAY

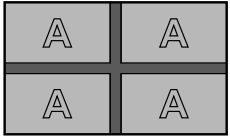







Item	Details
<b>VIDEO WALL UNIFORMITY</b>	<p>Reduces the peak of brightness for each display to enable as uniform display as possible. Select "OFF" or "ON".</p> <div style="display: flex; justify-content: space-around;"> <div style="text-align: center;"> <p>The brightness depends on each display's setting.</p>  <p>OFF</p> </div> <div style="text-align: center;"> <p>The brightness difference is minimized.</p>  <p>ON</p> </div> </div> <p><b>Note:</b> If you set VIDEO WALL UNIFORMITY to ON, the following menus will be unavailable and these settings will be fixed to the initial values. PICTURE menu: COLOR, TINT, INPUT LEVEL (ADVANCED SETTINGS)</p>

## ID Remote Control Function

You can set the remote control ID when you want to use this remote control on one of several different displays.

**Note:**

To operate this function, please purchase ID remote controller sold separately.  
Object model : EUR7636070R

- 1 Switch  to  on the right side.
- 2 Press the  button on the remote control.
- 3 Press one of  - ,  for the tens digit setting.
- 4 Press one of  - ,  for the units digit setting.

**Notes:**

- The numbers in 2, 3 and 4 should be set up quickly.
- Adjustable ID number range is 0 - 99.
- If a number button is pressed more than two times, the first two numbers become the ID number for the remote control.

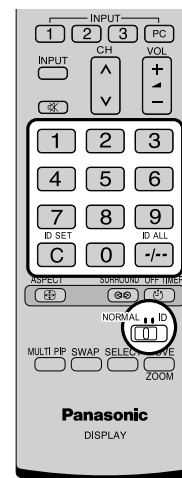

### ID remote control button operation

The operation is the same as normal remote control except for the  button.

### ID Cancellation

Press  button on remote control. (This has the same effect as pressing the , ,  buttons at the same time.)

**Notes:**

- Set the Remote ID "On" to operate the ID remote control.  
If Remote ID is set to "On", you can use the remote control without identical ID number during option menu display. (see page 56)
- The ID remote control cannot be used when ID select is set to anything other than 0, and the remote control ID is not the same as the ID select number (see page 56).



# SETUP for PORTRAIT

Divide an input image into 3 parts, and display one of them to a plasma display which is set vertically. The image will be enlarged 3 times and rotated 90-degree.

(Example)



## Notes:

- When using the PORTRAIT function with displays set vertically, "DISPLAY ORIENTATION" in SETUP menu has to be set to "PORTRAIT" (see page 46).
- Turn up the power switch for the upward direction when you set Display vertically.
- During Portrait display, the 3D images are displayed as 2D images.

## How to setup PORTRAIT

**1** Select "PORTRAIT SETUP" in "SETUP" menu and press button.

**2** Press to select the PORTRAIT SETUP.  
Press to select "ON" or "OFF".

**Note:**  
If you set PORTRAIT SETUP to ON, MULTI DISPLAY SETUP will be unavailable.

PORTRAIT SETUP	
PORTRAIT SETUP	OFF
SEAM HIDES VIDEO	OFF
VIEWING AREA	16:9
LOCATION	1
VIDEO WALL UNIFORMITY	OFF

**3** Press to select SEAM HIDES VIDEO.  
Press to select "OFF", "ON".

PORTRAIT SETUP	
PORTRAIT SETUP	OFF
SEAM HIDES VIDEO	OFF
VIEWING AREA	16:9
LOCATION	1
VIDEO WALL UNIFORMITY	OFF

To hide joints between displays.	To show joints between displays.
<p>Example</p> <p>Suitable for moving image display.</p>	<p>Example</p> <p>Suitable for still image display.</p>
ON	OFF

# SETUP for PORTRAIT

## 4 VIEWING AREA / LOCATION

**VIEWING AREA:** Set a mode of image division for PORTRAIT function.

**LOCATION:** Set a location of image to be displayed for PORTRAIT function.

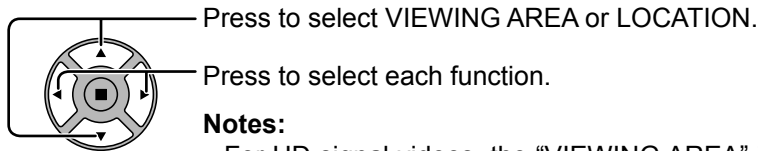

**Notes:**

- For HD signal videos, the “VIEWING AREA” is set at “16:9”, and cannot be changed.  
HD signal: 1125 (1080) / 60i • 50i • 60p • 50p • 24p • 25p • 30p • 24sF, 750 (720) / 60p • 50p, 1250 (1080) / 50i
- When “VIEWING AREA” is “16:9”, the aspect mode is set to “FULL”.

PORTRAIT SETUP	
PORTRAIT SETUP	OFF
SEAM HIDES VIDEO	OFF
VIEWING AREA	16:9
LOCATION	1
VIDEO WALL UNIFORMITY	OFF

### LOCATION setting

**When PORTRAIT SETUP “ON”:**

Display the image of the selected LOCATION.

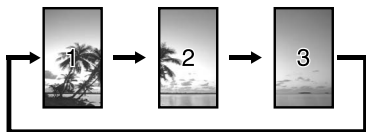

**When PORTRAIT SETUP is “OFF”:**

Represent an area of the selected LOCATION at a normal brightness and darken the rest of it.

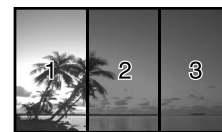

### VIEWING AREA and LOCATION

The mode of image division and the LOCATION by setting of VIEWING AREA is as follows.

VIEWING AREA: 16:9

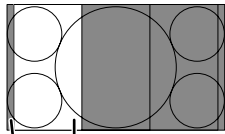

LOCATION 1

Undisplayed area (48 dots)

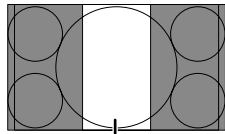

LOCATION 2

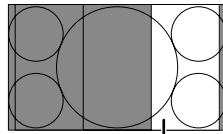

LOCATION 3

Suitable to display FULL images. NORMAL (4:3) images extend transversely. Both right and left sides of the image are cut by 48 dots.

VIEWING AREA: 4:3

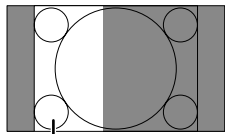

LOCATION 1

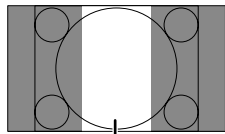

LOCATION 2

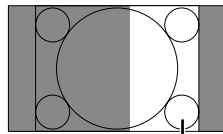

LOCATION 3

4:3 images are displayed without changing aspect ratio. Although the images of each LOCATION overlap, you can adjust POS./SIZE to display the image normally. (see page 26)

## 5 VIDEO WALL UNIFORMITY

Reduces the peak of brightness for each display to enable as uniform display as possible.

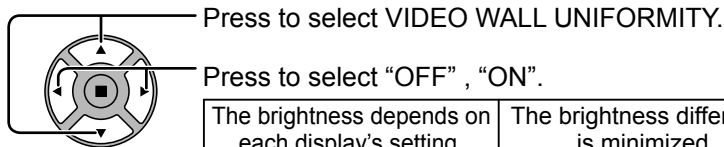

The brightness depends on each display's setting.



OFF

The brightness difference is minimized.



ON

PORTRAIT SETUP	
PORTRAIT SETUP	OFF
SEAM HIDES VIDEO	OFF
VIEWING AREA	16:9
LOCATION	1
VIDEO WALL UNIFORMITY	OFF

**Note:**

If you set VIDEO WALL UNIFORMITY to ON, the following menu will be unavailable and these settings will be fixed to the initial values. PICTURE menu: COLOR, TINT, INPUT LEVEL (ADVANCED SETTINGS)

# SETUP for Input Signals

## COMPONENT / RGB IN SELECT

---

COMPONENT  $\longleftrightarrow$  RGB

Select to match the signals from the source connected to the Component / RGB or PC input terminals.

Y, P<sub>B</sub>, P<sub>R</sub> signals  $\Leftrightarrow$  "COMPONENT"

RGB signals  $\Leftrightarrow$  "RGB"

**Note:**

Make setting of the selected input terminal (COMPONENT/RGB IN or PC IN).

---

## YUV / RGB IN SELECT

---

YUV  $\longleftrightarrow$  RGB

Select to match the signals from the source connected to the DVI input terminals.

YUV signals  $\Leftrightarrow$  "YUV"

RGB signals  $\Leftrightarrow$  "RGB"

**Notes:**

- Selection may not be possible, depending on which optional board is installed.
- Make setting of the selected input terminal (SLOT or DVI-D IN).

## SIGNAL menu

### Note:

“SIGNAL” setup menu displays a different setting condition for each input signal.

Select “SIGNAL” in “SETUP” menu and press  button.



For VIDEO (S VIDEO)

SIGNAL [ VIDEO ]	
3D Y/C FILTER (NTSC)	ON
COLOR SYSTEM	AUTO
3 : 2 PULLDOWN	OFF
NOISE REDUCTION	OFF

For RGB

SIGNAL [ RGB ]	
SYNC	AUTO
3 : 2 PULLDOWN	OFF
XGA MODE	AUTO
NOISE REDUCTION	OFF
H-FREQ.	63.98 kHz
V-FREQ.	60.02 Hz
SIGNAL FORMAT	1280×1024/60i

For COMPONENT

SIGNAL [ COMPONENT ]	
SYNC	AUTO
3 : 2 PULLDOWN	OFF
XGA MODE	AUTO
NOISE REDUCTION	OFF
H-FREQ.	63.98 kHz
V-FREQ.	60.02 Hz
SIGNAL FORMAT	1280×1024/60i

For Digital

SIGNAL [ Digital ]	
3 : 2 PULLDOWN	OFF
NOISE REDUCTION	OFF
H-FREQ.	63.98 kHz
V-FREQ.	60.02 Hz
DOT CLOCK FREQ.	108.0 MHz
SIGNAL FORMAT	1280×1024/60i

### • 3D Y/C FILTER (NTSC)

This menu is displayed when BNC Dual Video Terminal Board (TY-FB9BD) is installed to the unit. Set this menu when the moving image looks unnatural during Video (S Video) input signal.

ON  $\longleftrightarrow$  OFF

#### Note:

When ON, this setting only affects NTSC input signals.

### • COLOR SYSTEM

$\rightarrow$ AUTO $\longleftrightarrow$ PAL $\longleftrightarrow$ SECAM $\longleftrightarrow$ M.NTSC $\longleftrightarrow$ NTSC $\leftarrow$

Set the color system to match the input signal. When “AUTO” is set, COLOR SYSTEM will be automatically selected from NTSC/PAL/SECAM/M.NTSC.

To display PAL60 signal, select “AUTO” or “PAL”.

#### If the image becomes unstable:

With the system set on Auto, under conditions of low level or noisy input signals the image may in rare cases become unstable. Should this occur, set the system to match the format of the input signal.

### • 3:2 PULLDOWN

When “ON”, the display attempts to reproduce a more natural interpretation of sources such as movie pictures, which are recorded at 24 frames per second.

If the picture is not stable, turn the setting to “OFF”.

ON  $\longleftrightarrow$  OFF

#### Note:

When ON, this setting only affects the following signal input:

- NTSC / PAL signal input during Video (S Video) input signal.
- 525i(480i), 625i(575i), 1125(1080)/60i signal input during “COMPONENT” input signal.

### • XGA MODE

This menu is displayed when the input signal is analog (Component/PC).

This unit supports three types of XGA signals with 60Hz vertical frequency having different aspect ratios and sampling rates (1,024 × 768 @ 60Hz, 1,280 × 768 @ 60Hz and 1,366 × 768 @ 60Hz).

AUTO  $\longleftrightarrow$  1024×768  $\longleftrightarrow$  1280×768  $\longleftrightarrow$  1366×768

**AUTO:** Automatically selected from 1024×768/1280×768/1366×768.

Switch the setting to suit the input signal for better display depends on the angle of view or display resolution condition.

#### Note:

After making this setting, be sure to make each adjustment (such as “AUTO SETUP”) on the “POS./SIZE” menu as necessary. (see page 26)

## • SYNC

This function operates only during input from PC IN terminal.

### Setting RGB sync signal

Confirm that the input is set to RGB input (this setting is valid only for RGB input signal).

**AUTO:** The H and V sync or synchronized signal is automatically selected. If both input, it is selected the H and V sync.



**ON G:** Uses a synchronized signal on the Video G signal, which is input from the G connector.

### Setting Component sync signal

Confirm that the input is set to Component input (this setting is valid only for Component input signal).

**AUTO:** The H and V sync or synchronized signal is automatically selected. If both input, it is selected the H and V sync.



**ON Y:** Uses a synchronized signal on the Video Y signal, which is input from the Y connector.

#### Note:

Signals input to COMPONENT/RGB IN terminals correspond to SYNC ON G or SYNC ON Y.

## • SDI THROUGH

Set the active through function of the Dual Link HD-SDI Terminal Board (TY-FB11DHD).

**OFF** ↔ **ON**

**ON:** Enables active through.

**OFF:** Disables active through.

#### Note:

Settings can only be performed for this menu when a slot mounted with a Dual Link HD-SDI Terminal Board (TY-FB11DHD) is selected.

## • FRAME CREATION

Automatically compensates the picture frame rate and removes juddering movements to make the images smooth.

**OFF** ↔ **MID** ↔ **MAX**

#### Note:

Depending on the contents, images may be noisy. To prevent the noise, change the setting.

## • 3D REFRESH RATE

Reduces juddering or flicker of image due to lighting interference during 3D viewing.

**100Hz** ↔ **120Hz**

#### Note:

This setting is disabled when "FRAME CREATION" is set to "OFF".

## • HDMI RANGE

Switches the dynamic range according to the input signal from HDMI terminal.

**VIDEO(16-235)** ↔ **FULL(0-255)** ↔ **AUTO**

**VIDEO(16-235):** If the input signal is the video range, Example: HDMI terminal output for DVD player

**FULL(0-255):** If the input signal is full range, Example: HDMI terminal output for personal computer

**AUTO:** Switches the dynamic range automatically between "VIDEO(16-235)" and "FULL(0-255)" according to the input signal.

#### Note:

This function can be set only for HDMI signal input.

# SETUP for Input Signals

## • NOISE REDUCTION

Sets the following three NR (Noise Reduction) functions together.  
VIDEO NR, MOSQUITO NR, BLOCK NR

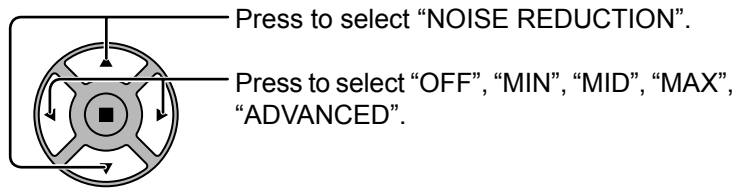

## Advanced NR

Sets the three NR functions separately.

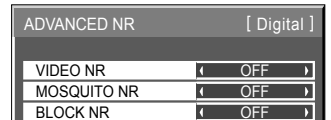
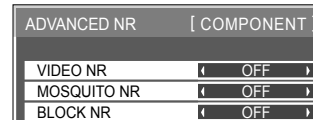
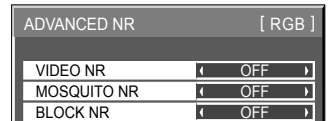
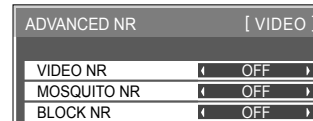
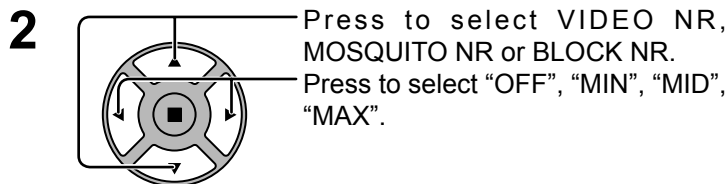
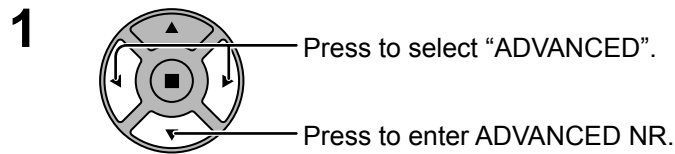

- VIDEO NR:** Automatically reduces unwanted picture noise.
- MOSQUITO NR:** Reduces mosquito noise around subtitles on MPEG videos.
- BLOCK NR:** Reduces block noise when playing MPEG videos.

### Note:

NOISE REDUCTION cannot be adjusted while a PC signal is being applied.

## • Input signal display

Displays the frequency and the type of the current input signal.

This display is valid only for COMPONENT/RGB/PC and Digital input signal.

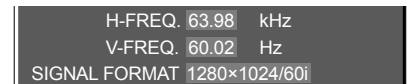

Display range:

- Horizontal 15 - 110 kHz
- Vertical 48 - 120 Hz



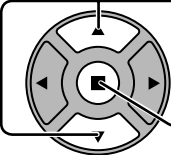
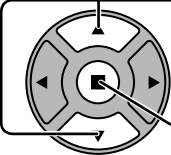
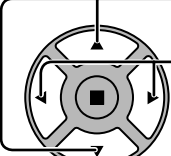
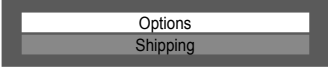
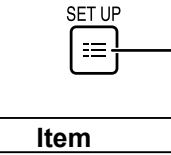
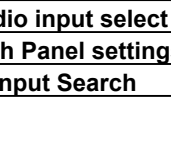

The dot clock frequency is displayed during DVI signal input.



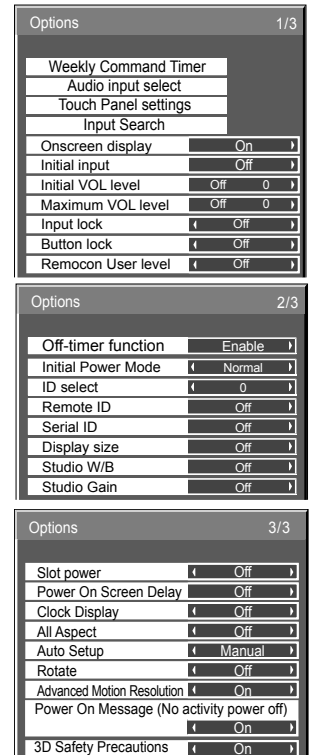





















# Options Adjustments

- 1  Press to display the SETUP menu.
- 2  Press to select "OSD LANGUAGE".  
 Press for more than 3 seconds.
- 3  Press to select "Options".  
 Options  
Shipping
- 4  Press to select your preferred menu.  
 Press to adjust the menu.
- 5  Press to exit from Options menu.









Item	Adjustments
<b>Weekly Command Timer</b>	Sets Weekly Command Timer. (see page 58)
<b>Audio input select</b>	Set up the sound when an image input is selected. (see page 60)
<b>Touch Panel settings</b>	Set while using Touch Panel (available as an option). (see page 61)
<b>Input Search</b>	Set auto input switching for when there is no signal. (see page 62)
<b>Onscreen display</b>	<p><b>On:</b> Displays all the following on screen.</p> <ul style="list-style-type: none"> <li>• Power on display</li> <li>• Input signal switch display</li> <li>• No signal display</li> <li>• Mute and the remaining time of off-timer after  was pressed.</li> </ul> <p><b>Off:</b> Hides all the items above from view.</p>
<b>Initial input</b>	<p>Adjusts the input signal when the unit is turned on.  <b>Off</b> ↔ <b>SLOT INPUT</b>*1 ↔ <b>VIDEO</b> ↔ <b>COMPONENT</b>*2 ↔ <b>HDMI</b> ↔ <b>DVI</b> ↔ <b>PC</b> ↔ <b>NETWORK</b></p> <p>*1 "SLOT INPUT" is displayed when an optional Terminal Board is installed.            When a Terminal Board with dual input terminals is installed, "SLOT INPUT A" and "SLOT INPUT B" are displayed.            *2 "COMPONENT" may be displayed as "RGB" depending on the setting of "COMPONENT/RGB-IN SELECT". (see page 51)</p> <p><b>Notes:</b></p> <ul style="list-style-type: none"> <li>• Only the adjusted signal is displayed. (see page 18)</li> <li>• This menu is available only when "Input lock" is "Off".</li> </ul>
<b>Initial VOL level</b>	<p>Press  button to adjust the volume when the unit is turned on.  <b>Off</b> ↔ <b>On</b></p> <p><b>Off:</b> Sets normal volume.  <b>On:</b> Sets your preferred volume.</p> <p><b>Notes:</b></p> <ul style="list-style-type: none"> <li>• When "Maximum VOL level" is "On", the volume can only be adjusted between 0 and your maximum range.</li> <li>• You can hear the changed volume regardless of your volume setting before opening the options menu if you adjust the volume when "Initial VOL level" is "On" and cursor is on the menu.</li> </ul>
<b>Maximum VOL level</b>	<p>Press  button to adjust the maximum volume.  <b>Off</b> ↔ <b>On</b></p> <p><b>Off:</b> Sets auto maximum volume.  <b>On:</b> Sets your preferred maximum volume.</p> <p><b>Notes:</b></p> <ul style="list-style-type: none"> <li>• If the "Maximum VOL level" is set lower than the "Initial VOL level", the "Initial VOL level" automatically becomes the same as the "Maximum VOL level".</li> <li>• The volume display can go up to 63 regardless of the settings.</li> <li>• You can hear the changed volume regardless of your volume setting before opening the options menu if you adjust the volume when "Maximum VOL level" is "On" and cursor is on the menu.</li> </ul>

# Options Adjustments

Item	Adjustments
<b>Input lock</b>	Locks the input switch operation. <b>Off</b> ↔ <b>SLOT INPUT</b> *1 ↔ <b>VIDEO</b> ↔ <b>COMPONENT</b> *2 ↔ <b>HDMI</b> ↔ <b>DVI</b> ↔ <b>PC</b> ↔ <b>NETWORK</b> *1 "SLOT INPUT" is displayed when an optional Terminal Board is installed. When a Terminal Board with dual input terminals is installed, "SLOT INPUT A" and "SLOT INPUT B" are displayed. *2 "COMPONENT" may be displayed as "RGB" depending on the setting of "COMPONENT/RGB-IN SELECT". (see page 51) <b>Notes:</b> <ul style="list-style-type: none"> <li>• Only the adjusted signal is displayed (see page 18).</li> <li>• Input switch can be used when this is set to "Off".</li> </ul>
<b>Button lock</b>	<b>Off</b> ↔ <b>MENU&amp;ENTER</b> ↔ <b>On</b> <b>Off:</b> All the buttons on main unit can be used. <b>MENU&amp;ENTER:</b> Locks  and  buttons on main unit. <b>On:</b> Locks all the button on main unit. Sets Button lock with the unit buttons in the following procedure. <b>Off:</b> Press  four times → Press  four times → Press  four times → Press  <b>MENU&amp;ENTER:</b> Press  four times → Press  four times → Press  four times → Press  <b>On:</b> Press  four times → Press  four times → Press  four times → Press 
<b>Remocon User level</b>	<b>Off</b> ↔ <b>User1</b> ↔ <b>User2</b> ↔ <b>User3</b> <b>Off:</b> You can use all of the buttons on the remote control. <b>User1:</b> You can only use  ,  ,  ,  ,  ,  ,  buttons on the remote control. <b>User2:</b> You can only use  button on the remote control. <b>User3:</b> Locks all the buttons on remote control.
<b>Off-timer function</b>	<b>Enable:</b> Enables the "Off-timer function". <b>Disable:</b> Disables the "Off-timer function". <b>Note:</b> When "Disable" is set, the Off-timer is cancelled.
<b>Initial Power Mode</b>	<b>Normal</b> ↔ <b>Standby</b> ↔ <b>On</b> Sets the power mode of the unit for when the power recovers from failure or after plugging off and in again. <b>Normal:</b> Power returns in as the same state as before the power interruption. <b>Standby:</b> Power returns in standby mode. (Power Indicator : red/orange) <b>On:</b> Power returns in power On. (Power Indicator : green) <b>Note:</b> When using multiple displays, "Standby" is preferred to be set in order to reduce a power load.
<b>ID select</b>	Sets panel ID number when panel is used in "Remote ID" or "Serial ID". Set value range: 0 - 100 (Standard value: 0)
<b>Remote ID</b>	The setting of this menu is valid only when using ID remote control. <b>Off:</b> Disables ID remote control functions. You can use normal remote control operations. <b>On:</b> Enable ID remote control functions. <b>Note:</b> To use the ID remote control function, it is necessary to set each ID number of remote control and display unit. About the setting method, please refer to "ID Remote Control Function" (see page 48) and "ID select" (above-mentioned).
<b>Serial ID</b>	Sets the panel ID Control. <b>Off:</b> Disables external control by the ID. <b>On:</b> Enables the external control by the ID.
<b>Display size</b>	Adjusts the image display size on screen. <b>Off:</b> Sets the normal image display size on screen. <b>On:</b> Sets the image display size approximately 95 % of the normal image display. <div style="display: flex; justify-content: space-around; align-items: center;"> <div style="text-align: center;"> <p><b>Off</b></p>  </div> <div style="text-align: center;"> <p><b>On</b></p>  </div> </div> <b>Notes:</b> <ul style="list-style-type: none"> <li>• This setting is valid only when the input signals are as follows;              NTSC, PAL, SECAM, M.NTSC, PAL60, PAL-M, PAL-N (Video)              525i, 525p, 625i, 625p, 750/60p, 750/50p, 1125/60i, 1125/50i, 1125/24sF, 1125/25p, 1125/24p, 1125/30p, 1125/60p, 1125/50p, 1250/50i (Component Video, RGB, DVI, SDI, HDMI)</li> <li>• This setting is invalid when digital zoom, Multi display or Portrait display is selected.</li> <li>• When "Display size" is set to "On", "H-POS" and "V-POS" in "POS./SIZE" can be adjusted.</li> <li>• Refer to each board's operating instruction for DVI, SDI, HDMI's corresponding signals.</li> </ul>



# Options Adjustments

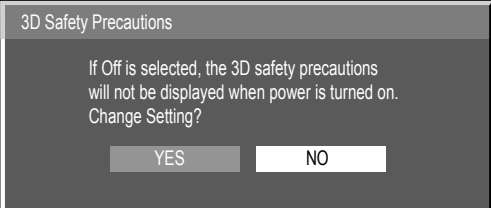

Item	Adjustments
Studio W/B	<p><b>Off:</b> Nullify all the settings adjusted.</p> <p><b>On:</b> Sets the color temperature for TV studio.</p> <p><b>Note:</b> Valid only when the "WARM" is set as "COLOR TEMP" in PICTURE menu.</p>
Studio Gain	<p>Sharpens the contrast for a better view when a part of the image is too light to see.</p> <p><b>Off:</b> Disables "Studio Gain".</p> <p><b>On:</b> Enables "Studio Gain".</p> <p><b>Note:</b> This setting is valid only when the input signals are as follows: Component Video, RGB (analog), SDI, HDMI</p>
Slot power	<p><b>Off</b> ↔ <b>Auto</b> ↔ <b>On</b></p> <p><b>Off:</b> Power is not transmitted to the slot power.</p> <p><b>Auto:</b> Power is transmitted to the slot power only when main power is on.</p> <p><b>On:</b> Power is transmitted to the slot power when main power is on or in the standby state.</p> <p><b>Note:</b> In some cases, power is transmitted to the slot power when main power is on or in the standby state regardless of the slot power setting.</p>
Power On Screen Delay	<p><b>Off</b> ↔ <b>1</b> ↔ <b>2</b> ↔ <b>3</b>... ↔ <b>30</b></p> <p>You can set the power-on delay time of the displays to reduce the power load, when you press  to turn on the multiple displays that are set together, for example, on MULTI DISPLAY system. Set each display's setting individually.</p> <p><b>Off:</b> The display will be turned on at the same time as  is pressed.</p> <p><b>1 to 30 (sec.):</b> Set the power-on delay time (second). After pressing , the display will be powered on with time delay depending on this setting.</p> <p><b>Notes:</b></p> <ul style="list-style-type: none"> <li>• During this function is working, the power indicator is blinking green.</li> <li>• This function also works when the power recovers from failure or after plugging off and in again the power cord. After you unplug and plug the power cord in while the unit is in standby mode and also the power is being supplied to a terminal board, the unit will start supplying the power to the board with time delay according to the setting. The power indicator lights up red first and it turns orange when the power starts being supplied to the board.</li> </ul>
Clock Display	<p><b>Off:</b> Not display the clock.</p> <p><b>On:</b> Display the clock.</p> <p>The clock is displayed at the lower left of the screen when  button is pressed.</p> <p><b>Note:</b> When "DAY/TIME SETUP" is not set, the clock is not displayed even if "Clock Display" is "On" (see page 36)</p> 
All Aspect	<p>Sets All Aspect mode (advanced aspect setting) or default aspect mode. With each press of  button, the aspect changes in the selected mode.</p> <p><b>Off:</b> Default aspect mode</p> <p><b>On:</b> All Aspect mode</p> <p>Aspect mode of each setting is as follows: (Example: HD signal)</p> <p><b>Off</b> 4:3→H-FILL→ZOOM→FULL→JUST</p> <p><b>On</b> 4:3 (1)→4:3 (2)→4:3 Full→Zoom1→Zoom2→Zoom3→16:9→14:9→Just1→Just2</p>
Auto Setup	<p>Sets the operational mode of the automatic position adjustment in the POS./SIZE menu.</p> <p><b>Manual:</b> Automatic position adjustment starts when  is pressed on the remote control or automatic position adjustment is executed from the POS./SIZE menu.</p> <p><b>Auto:</b> Other than remote control or menu operation, automatic position adjustment starts: When the display power is turned ON. When the input signal is switched.</p>
Rotate	<p><b>Off:</b> Does not rotate the image.</p> <p><b>On:</b> Rotates the image 180 degrees.</p> <p><b>Note:</b> During the image is rotated, the 3D images are displayed as 2D images.</p>
Advanced Motion Resolution	<p>Displays motion picture images at higher resolution.</p> <p><b>On</b> ↔ <b>Off</b></p> <p><b>Notes:</b></p> <ul style="list-style-type: none"> <li>• Please set to "Off" if images look unnatural.</li> <li>• This function is disabled during 3D images.</li> </ul>
Power On Message (No activity power off)	<p>Whether to show/hide No activity power off Precautions at the time of power ON is set.</p> <p><b>On:</b> The warning precautions are shown at the time of power ON.</p> <p><b>Off:</b> The warning precautions are not shown at the time of power ON.</p> <p><b>Note:</b> This setting is enabled only if "NO ACTIVITY POWER OFF" is "ENABLE" (see page 46).</p>

# Options Adjustments

Item	Adjustments
3D Safety Precautions	<p>3D Safety Precautions show/hide is set during power ON.  <b>On:</b> 3D Safety Precaution is shown every time when the power is ON.  <b>Off:</b> 3D Safety Precaution is not shown when the power is ON.                      When the setting changes from "On" to "Off", the confirmation screen is displayed as below.                      Pressing "YES" switches the setting.</p> 

## Normalization

When both main unit buttons and remote control are disabled due to the "Button lock", "Remocon User level" or "Remote ID" adjustments, set all the values "Off" so that all the buttons are enabled again.

Press the  button on main unit together with  button on the remote control and hold for more than 5 seconds. The "Shipping" menu is displayed and the lock is released when it disappears.

# Weekly Command Timer

You can set 7-day timer programming by setting time and command.

## Note:

Before setting Weekly Command Timer, set DAY/TIME SETUP. (see page 36)

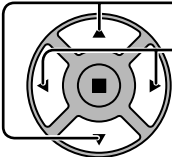
- 1**  Press to select Function.  
 Press to select "On".

**Note:**

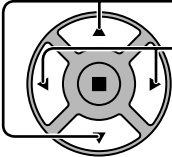
  - When Function is set to On, ON/OFF TIMER SETUP (see page 36) is unavailable and INTERVAL / TIME OF DAY in MODE of SCREENSAVER (see page 38) cannot be selected.
- 2**  Press to select a day.  
 Press to select a program number.

**Note:**

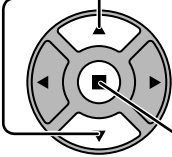
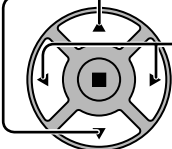
  - You can set the program from 1 to 7.  
 --- indicates unset.
- 3**  Press to select Program Edit.  
 Press to show the Program Edit screen.
- 4**  Press to select Program.  
 Press to change the program numbers (1-7).

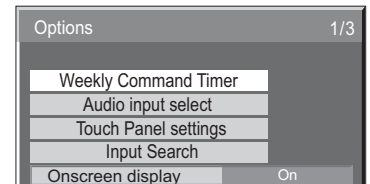

Press ACTION (■) button

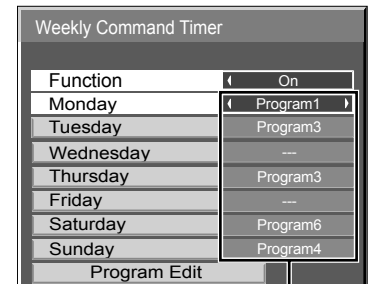

Program number

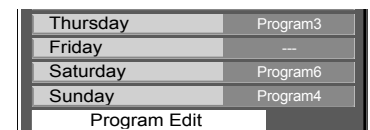

Program Edit screen

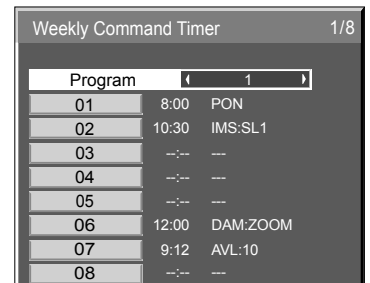

- 5**
- 
- Press to select a command number.
  - Press to show the previous / next command pages (1-8) of the selected program.
  - Press to show the command setting screen.

Program	1	
01	8:00	PON
02	10:30	IMS:SL1
03	--:--	---
04	--:--	---
05	--:--	---
06	12:00	DAM:ZOOM
07	9:12	AVL:10
08	--:--	---

Program	1	
57	20:00	AVL:00
58	20:30	DAM:NORM
59	22:00	POF
60	--:--	---
61	--:--	---
62	--:--	---
63	--:--	---
64	--:--	---

Command (--- indicates unset)  
Set time of timer (--:-- indicates unset)  
Command numbers

- 6**
- 
- Press to select Command No.
  - Press to select a command number.

Command setting screen

Program	1	
Command No	◀ 02 ▶	
Time	10:30	
Command	IMS:SL1	

- 7**
- 
- Press to select Time / Command.
  - Press to set each item.
- Time: Set the time to execute a command program.  
Pressing “◀” or “▶” button once changes “Time” 1 minute.  
Pressing “◀” or “▶” button continuously changes “Time” by 15 minutes.
- Command: Select a command to execute at the set time. This unit has 64 commands to set. (see page 67)

Program	1	
Command No	02	
Time	◀ 10:30 ▶	
Command	◀ IMS:SL1 ▶	

- Notes:**
- Command is performed in order of execution time, regardless of the command number.
  - If a command execution time overlaps with that of other commands, these commands are performed in number order.
  - Pressing  $\overset{N}{\bigcirc}$ , Time becomes --:-- and Command becomes ---.

**Note:**  
Press  $\overset{R}{\bigcirc}$  to return to the previous screen.

## Audio input select

Set up the sound when an image input is selected.

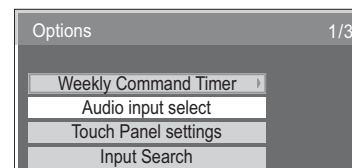

↓ Press ACTION (■) button

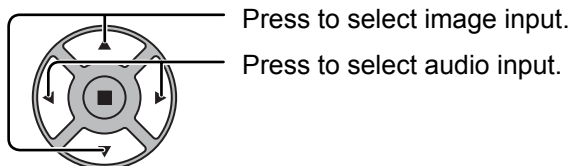
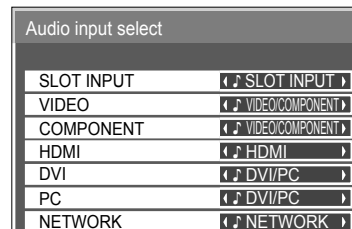

Image input	Audio input
[SLOT INPUT]*1	SLOT INPUT / VIDEO/COMPONENT / DVI/PC / NETWORK / NO AUDIO
[VIDEO]	SLOT INPUT / VIDEO/COMPONENT / DVI/PC / NETWORK / NO AUDIO
[COMPONENT]*2	SLOT INPUT / VIDEO/COMPONENT / DVI/PC / NETWORK / NO AUDIO
[HDMI]	SLOT INPUT / VIDEO/COMPONENT / HDMI / DVI/PC / NETWORK / NO AUDIO
[DVI]	SLOT INPUT / VIDEO/COMPONENT / DVI/PC / NETWORK / NO AUDIO
[PC]	SLOT INPUT / VIDEO/COMPONENT / DVI/PC / NETWORK / NO AUDIO
[NETWORK]	SLOT INPUT / VIDEO/COMPONENT / DVI/PC / NETWORK / NO AUDIO

VIDEO/COMPONENT: Sound input for both VIDEO and COMPONENT.

DVI/PC: Sound input for both DVI and PC.

NO AUDIO: No audio input (Mute)

\*1 "SLOT INPUT" is displayed when a Terminal Board is installed.

\*2 "COMPONENT" may be displayed as "RGB" depending on the setting of "COMPONENT/RGB-IN SELECT".  
(see page 51)

### When a Terminal Board with dual input terminals is installed

"SLOT INPUT" is displayed as "SLOT INPUT A" and "SLOT INPUT B" and independent settings are available. To set other image inputs, you can select "SLOT INPUT A" and "SLOT INPUT B".

Image input	Audio input
[SLOT INPUT A]	SLOT INPUT A / VIDEO/COMPONENT / DVI/PC / NETWORK / NO AUDIO
[SLOT INPUT B]	SLOT INPUT B / VIDEO/COMPONENT / DVI/PC / NETWORK / NO AUDIO
[VIDEO]	SLOT INPUT A / SLOT INPUT B / VIDEO/COMPONENT / DVI/PC / NETWORK / NO AUDIO
[COMPONENT]	SLOT INPUT A / SLOT INPUT B / VIDEO/COMPONENT / DVI/PC / NETWORK / NO AUDIO
[HDMI]	SLOT INPUT A / SLOT INPUT B / VIDEO/COMPONENT / HDMI / DVI/PC / NETWORK / NO AUDIO
[DVI]	SLOT INPUT A / SLOT INPUT B / VIDEO/COMPONENT / DVI/PC / NETWORK / NO AUDIO
[PC]	SLOT INPUT A / SLOT INPUT B / VIDEO/COMPONENT / DVI/PC / NETWORK / NO AUDIO
[NETWORK]	SLOT INPUT A / SLOT INPUT B / VIDEO/COMPONENT / DVI/PC / NETWORK / NO AUDIO

When Image input and Audio input differ from each other, the Audio input is displayed as below.

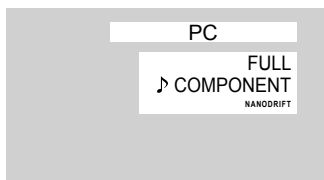

### Notes:

- HDMI Audio is selectable only for HDMI Input.
- You cannot set audio of B for SLOT INPUT A, or audio of A for SLOT INPUT B.

## Touch Panel settings (Settings when using Touch Panel)

The mode to restrict NANODRIFT SAVER (see page 41) operation when using Touch Panel (available as an option) is set up.

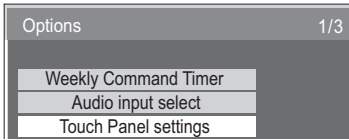

↓ Press ACTION (■) button

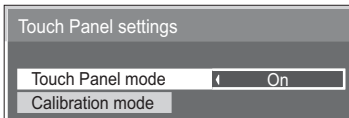

Set "Touch Panel mode" to "On".

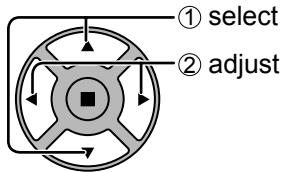

### NANODRIFT SAVER in Touch Panel mode: On

The value set for NANODRIFT turns into "ON" and displayed in gray.  
The moving distance of NANODRIFT is limited to 5 × 5 dots to prevent pointer drift on a touch panel.

### Calibration mode

This setting is used in calibrating a touch panel.

You can configure the setting if "Touch Panel mode" is "On".

Select "Calibration mode" and then press .

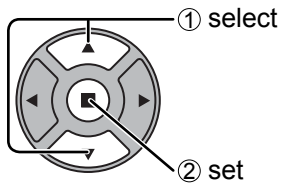
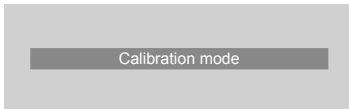
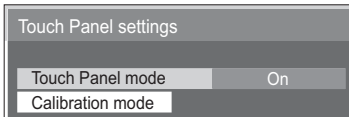

### When the menu is not displayed (normal screen)

Hold down  for over 3 seconds.

The screen is displayed in the middle and NANODRIFT is deactivated for 180 seconds. After 180 seconds or when you have the menu displayed with a remote control, Calibration mode is cancelled.

### Note:

For information on how to set up Calibration, please see Touch Panel instruction manual.

## Input Search

When a signal is not detected, another input with a signal is automatically selected.

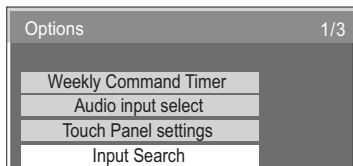

↓ Press ACTION (■) button

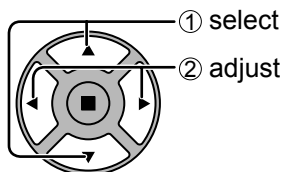
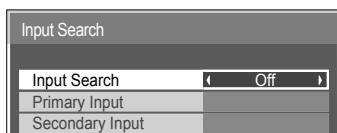

### Input Search

**Off:** When there is no signal, the input is not switched automatically.

**All Inputs:** Searches all inputs and switches to an input with a signal.

Input search is executed in the following order.

(Example) When the current input is PC



**Priority:** Searches “Primary Input” and “Secondary Input” in order and switches to an input with a signal.

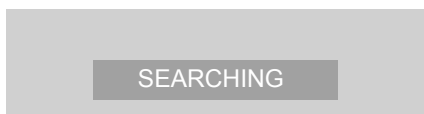

“SEARCHING” is displayed during the input search.

### Primary Input, Secondary Input

Set the input to search when “Priority” is selected.

**(NONE) ↔ SLOT INPUT\* ↔ VIDEO ↔ COMPONENT ↔ HDMI ↔ DVI ↔ PC ↔ NETWORK**

\* “SLOT INPUT” is displayed when an optional Terminal Board is installed.











When a Terminal Board with dual input terminals is installed, “SLOT INPUT A” and “SLOT INPUT B” are displayed.

### Notes:

- This menu is available only when “Input lock” is “Off”. (see page 56)
- If the input is changed by this function, the last input is selected when the power is turned on next time.  
If you wish to retain the original input when the power is turned on, set “Initial input” to the original input. (see page 55)

# Troubleshooting

Before you call for service, determine the symptoms and make a few simple checks as shown below.

Symptoms		Checks
Picture	Sound	
 Interference	 Noisy Sound	Electrical Appliances Cars / Motorcycles Fluorescent light
 Normal Picture	 No Sound	Volume (Check whether the mute function has been activated on the remote control.) Check if speakers are connected properly.
 No Picture	 No Sound	Not plugged into AC outlet Not switched on PICTURE and BRIGHTNESS/Volume setting (Check by pressing the power switch or stand-by button on the remote control.)
 No Picture	 Normal Sound	If a signal with a non-applicable color system format, or frequency is input, only the input terminal indication is displayed.
 No Color	 Normal Sound	Color controls set at minimum level. (see page 29, 30) COLOR SYSTEM (see page 52)
No remote control operations can be performed.		Check whether the batteries have discharged completely and, if they have not, whether they were inserted properly. Check whether the remote control sensor is exposed to an outdoor light or a strong fluorescent light. Check whether the remote control designed specifically for use with the unit is being used. (The unit cannot be operated by any other remote control.)
A cracking sound is sometimes heard from the unit.		If there is nothing wrong with the picture or sound, this is the sound of the cabinet undergoing very slight contractions in response to changes in the room temperature. There are no adverse effects on the performance or other aspects.
The top or bottom of the picture on the screen is cut off when I use the zoom function.		Adjust the position of the picture on the screen.
Areas at the top and bottom of the screen where the image is missing appear when I use the zoom function.		When using a video software program (such as a cinema size program) with a screen wider than one in the 16:9 mode, blank areas separate from the images are formed at the top and bottom of the screen.
I can hear sounds coming from inside the unit.		When the power is turned on, a sound of the display panel being driven may be heard: This is normal and not indicative of malfunctioning.
Parts of the unit become hot.		Even when the temperature of parts of the front, top and rear panels has risen, these temperature rises will not pose any problems in terms of performance or quality.
Power automatically turns off unexpectedly.		Check the settings of "PC POWER MANAGEMENT", "DVI-D POWER MANAGEMENT", "NO SIGNAL POWER OFF" and "NO ACTIVITY POWER OFF" in the SETUP menu. Any of them may be set to "ON (ENABLE)". (see page 43, 46)
Power indicator is blinking in red.		There is possibility of malfunction. Please contact an Authorized Service Center.
This Plasma Display uses special image processing.		Hence a slight time lag may occur between image and audio, depending on the type of input signal. However, this is not a malfunction.

## Plasma Display panel

Symptoms	Check
The screen darkens slightly when bright pictures with minimal movements are shown.	The screen will darken slightly when photos, still images of a computer or other pictures with minimal movements are shown for an extended period. This is done to reduce image retention on the screen and the shortening of the screen's service life: It is normal and not indicative of malfunctioning.
It takes a while for the picture to appear.	The unit digitally processes the various signals in order to reproduce esthetically pleasing images. As such, it sometimes takes a few moments for the picture to appear when the power has been turned on, when the input has been switched.
The edges of the images flicker.	Due to the characteristics of the system used to drive the panel, the edges may appear to flicker in the fast-moving parts of the images: This is normal and not indicative of malfunctioning.
The brightness on both sides of images in 4:3 mode changes.	When viewing the side panels at the "BRIGHT" or "MID" setting, the brightness on both sides may change depending on the kind of program shown: This is normal and not indicative of malfunctioning.
Some parts of the screen do not light up.	The plasma display panel is manufactured using an extremely high level of precision technology, however, sometimes some parts of the screen may be missing picture elements or have luminous spots. This is not a malfunction.
 <p>Image retention appears</p>	Do not allow a still picture to be displayed for an extended period, as this can cause a permanent image retention to remain on the Plasma Display. Examples of still pictures include logos, video games, computer images, teletext and images displayed in 4:3 mode. <b>Note:</b> The permanent image retention on the Plasma Display resulting from fixed image use is not an operating defect and as such is not covered by the Warranty. This product is not designed to display fixed images for extended periods of time.
Whirring sounds can be heard from the display unit.	The display unit is fitted with a cooling fan to dissipate heat generated during normal use. The whirring sound is caused by rotation of the fan and is not a malfunction.

# List of Aspect Modes

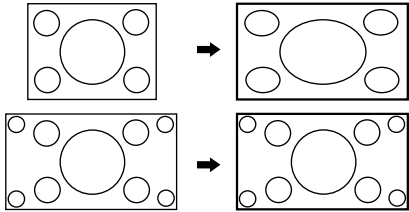
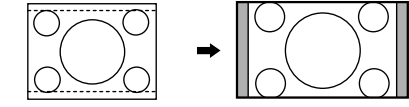
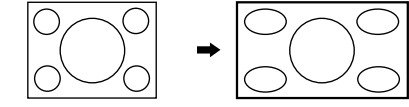
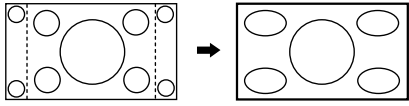
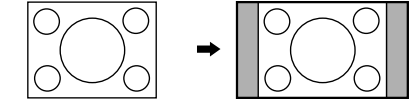
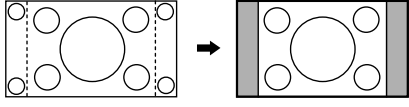
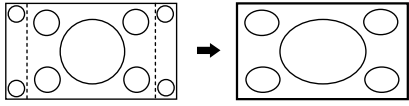
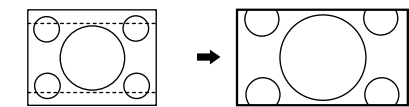
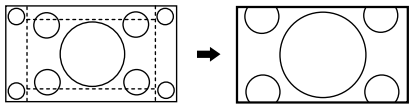
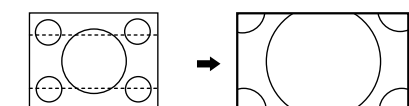
Aspect mode		Picture → Enlarged screen	Description
All Aspect: On	Factory setting All Aspect: Off		
16:9	FULL		The display of the pictures fills the screen. In the case of SD signals, pictures with a 4:3 aspect ratio are enlarged horizontally, and displayed. This mode is suited to displaying anamorphic pictures with a 16:9 aspect ratio.
14:9	–		Letterbox pictures with a 14:9 aspect ratio are enlarged vertically and horizontally so that their display fills the screen vertically and is slightly smaller than the screen horizontally. The top and bottom edges of the pictures are cut off. Side panels are displayed at the left and right edges of the screen.
Just ----- Just1	JUST		Pictures with a 4:3 aspect ratio are enlarged horizontally so that the picture distortion is minimized. The display of the areas around the left and right edges of the screen is slightly elongated.
Just2	JUST		Pictures with a 4:3 aspect ratio are enlarged horizontally so that the picture distortion is minimized. The left and right edges of the pictures are cut off. The display of the areas around the left and right edges of the screen is slightly elongated.
4:3 ----- 4:3 (1)	4:3		Pictures with a 4:3 aspect ratio are displayed with their original aspect ratio. Side panels are displayed at the left and right edges of the screen.
4:3 (2)	4:3		Pictures with a 4:3 aspect ratio are displayed with their original aspect ratio. The left and right edges of the pictures are masked by side panels.
4:3 Full	H-FILL		Pictures with a 4:3 aspect ratio are enlarged horizontally so that their display fills the screen. The left and right edges of the pictures are cut off.
Zoom ----- Zoom1	ZOOM		Letterbox pictures with a 16:9 aspect ratio are enlarged vertically and horizontally so that their display fills the screen. The top and bottom edges of the pictures are cut off.
Zoom2	ZOOM		Letterbox pictures with a 16:9 aspect ratio are enlarged vertically and horizontally so that their display fills the screen. The top and bottom edges as well as the left and right edges of the pictures are cut off.
Zoom3	–		Letterbox pictures with a 2.35:1 aspect ratio are enlarged vertically and horizontally so that their display fills the screen vertically and is slightly larger than the screen horizontally. The top and bottom edges as well as the left and right edges of the pictures are cut off.



# Applicable Input Signals

\*Mark: Applicable input signal

	Signal name	Horizontal frequency (kHz)	Vertical frequency (Hz)	COMPONENT / RGB IN / PC IN (Dot clock (MHz))	DVI-D IN (Dot clock (MHz))	HDMI
1	525 (480) / 60i	15.73	59.94	* (13.5)	* (27.0)	*
2	525 (480) / 60p	31.47	59.94	* (27.0) *5	* (27.0)	*
3	625 (575) / 50i	15.63	50.00	* (13.5)		
4	625 (576) / 50i	15.63	50.00		* (27.0)	*
5	625 (575) / 50p	31.25	50.00	* (27.0)		
6	625 (576) / 50p	31.25	50.00		* (27.0)	*
7	750 (720) / 60p	45.00	60.00	* (74.25)	* (74.25)	*
8	750 (720) / 50p	37.50	50.00	* (74.25)	* (74.25)	*
9	1,125 (1,080) / 60p	67.50	60.00	* (148.5) *1	* (148.5)	*
10	1,125 (1,080) / 60i	33.75	60.00	* (74.25) *1	* (74.25)	*
11	1,125 (1,080) / 50p	56.26	50.00	* (148.5) *1	* (148.5)	*
12	1,125 (1,080) / 50i	28.13	50.00	* (74.25) *1	* (74.25)	*
13	1,125 (1,080) / 24sF	27.00	48.00	* (74.25) *2		
14	1,125 (1,080) / 30p	33.75	30.00	* (74.25) *1	* (74.25)	
15	1,125 (1,080) / 25p	28.13	25.00	* (74.25) *1	* (74.25)	
16	1,125 (1,080) / 24p	27.00	24.00	* (74.25) *1	* (74.25)	*
17	1,250 (1,080) / 50i	31.25	50.00	* (74.25) *3		
18	2,048 × 1,080 / 24sF *7	27.00	48.00			
19	2,048 × 1,080 / 24p *7	27.00	24.00			
20	640 × 400 @70 Hz	31.46	70.07	* (25.17)		
21	640 × 480 @60 Hz	31.47	59.94	* (25.18) *6	* (25.18)	*
22	640 × 480 @72 Hz	37.86	72.81	* (31.5)		
23	640 × 480 @75 Hz	37.50	75.00	* (31.5)		
24	640 × 480 @85 Hz	43.27	85.01	* (36.0)		
25	800 × 600 @56 Hz	35.16	56.25	* (36.0)		
26	800 × 600 @60 Hz	37.88	60.32	* (40.0)	* (40.0)	*
27	800 × 600 @72 Hz	48.08	72.19	* (50.0)		
28	800 × 600 @75 Hz	46.88	75.00	* (49.5)		
29	800 × 600 @85 Hz	53.67	85.06	* (56.25)		
30	852 × 480 @60 Hz	31.47	59.94	* (33.54) *6	* (34.24)	*
31	1,024 × 768 @50 Hz	39.55	50.00		* (51.89)	*
32	1,024 × 768 @60 Hz	48.36	60.00	* (65.0)	* (65.0)	*
33	1,024 × 768 @70 Hz	56.48	70.07	* (75.0)		
34	1,024 × 768 @75 Hz	60.02	75.03	* (78.75)		
35	1,024 × 768 @85 Hz	68.68	85.00	* (94.5)		
36	1,066 × 600 @60 Hz	37.64	59.94	* (53.0)	* (53.0)	*
37	1,152 × 864 @60 Hz	53.70	60.00		* (81.62)	*
38	1,152 × 864 @75 Hz	67.50	75.00	* (108.0)		
39	1,280 × 768 @60 Hz	47.70	60.00	* (80.14)		
40	1,280 × 800 @60 Hz (1)	49.31	59.91	* (71.0)	* (71.0)	*
41	1,280 × 800 @60 Hz (2)	49.70	59.81	* (83.5)	* (83.5)	*
42	1,280 × 960 @60 Hz	60.00	60.00	* (108.0)		
43	1,280 × 960 @85 Hz	85.94	85.00	* (148.5)		
44	1,280 × 1,024 @60 Hz	63.98	60.02	* (108.0)	* (108.0)	*
45	1,280 × 1,024 @75 Hz	79.98	75.03	* (135.0)		
46	1,280 × 1,024 @85 Hz	91.15	85.02	* (157.5)		
47	1,366 × 768 @50 Hz	39.55	50.00		* (69.92)	*
48	1,366 × 768 @60 Hz	48.36	60.00	* (86.71)	* (87.44)	*
49	1,400 × 1,050 @60 Hz	65.22	60.00		* (122.61)	*
50	1,440 × 900 @60 Hz (1)	55.47	59.90	* (88.75)	* (88.75)	*
51	1,440 × 900 @60 Hz (2)	55.93	59.89	* (106.5)	* (106.5)	*
52	1,600 × 1,200 @60 Hz	75.00	60.00	* (162.0)	* (162.0)	*
53	1,600 × 1,200 @65 Hz	81.25	65.00	* (175.5)		
54	1,920 × 1,080 @60 Hz	67.50	60.00	* (148.5) *4	* (148.5)	*
55	1,920 × 1,200 @60 Hz	74.04	59.95		* (154.0)	*
56	Macintosh13" (640 × 480)	35.00	66.67	* (30.24)		
57	Macintosh16" (832 × 624)	49.72	74.54	* (57.28)		
58	Macintosh21" (1,152 × 870)	68.68	75.06	* (100.0)		

\*1: Based on SMPTE 274M standard.

\*2: Based on SMPTE RP211 standard.

\*3: Based on SMPTE 295M standard.

\*4: The input signal is recognized as 1,125 (1,080) / 60p.

\*5: When selected the RGB format and 525p signal input to the PC IN terminal, it is recognized as VGA 60Hz signal.

\*6: When inputted VGA 60Hz format signal from the other than PC IN terminal, it is recognized as 525p signal.

\*7: Based on SMPTE 292M and 372M standards. These signals can be received when the Dual Link HD-SDI Terminal Board (TY-FB11DHD) is installed.

**Note:** Signals without above specification may not be displayed properly.







# Applicable Input Signals

## Video input (VIDEO)

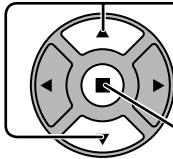
	Signal name	Horizontal frequency(kHz)	Vertical frequency(Hz)
1	NTSC	15.73	59.94
2	PAL	15.63	50.00
3	PAL60	15.73	59.94
4	SECAM	15.63	50.00
5	Modified NTSC	15.73	59.94

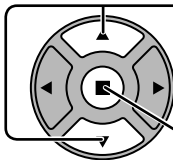
## Shipping condition

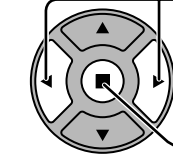
This function allows you to reset the unit to the factory setting.

-  Press to display the SETUP menu.
-  Press to select "OSD LANGUAGE".  
 Press for more than 3 seconds.
-  Press to select "Shipping".  
 Press to display the Shipping menu.
-  Press to select "YES".  
 Press to confirm.
- Wait for 10 seconds.
-  Press the power switch (⏻/⏿) on main unit to turn the power off.

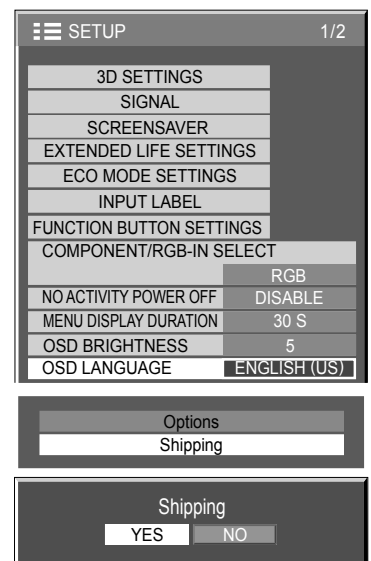

[from the unit]

- Press the MENU button till the SETUP menu is displayed.
- Press the Volume Up "+" or Down "-" button to select "OSD LANGUAGE".
- Press and hold the ENTER button till the Shipping menu is displayed.
- Press the Volume Up "+" or Down "-" button to select "YES".
- Press the ENTER button and wait for 10 sec.
- Press the power switch (⏻/⏿) on main unit to turn the power off.

# Command list of Weekly Command Timer

No.	Command	Control details
1	AAC:MENCLR	Audio Menu (CLEAR)
2	AAC:MENDYN	Audio Menu (DYNAMIC)
3	AAC:MENSTD	Audio Menu (STANDARD)
4	AAC:SURMON	Surround (ON)
5	AAC:SUROFF	Surround (OFF)
6	AMT:0	Audio Mute (OFF)
7	AMT:1	Audio Mute (ON)
8	-	-
9	-	-
10	AVL:00	Audio Volume (00)
11	AVL:10	Audio Volume (10)
12	AVL:20	Audio Volume (20)
13	AVL:30	Audio Volume (30)
14	AVL:40	Audio Volume (40)
15	AVL:50	Audio Volume (50)
16	AVL:60	Audio Volume (60)
17	DAM:FULL	Aspect (FULL)
18	DAM:JUST	Aspect (JUST)
19	DAM:NORM	Aspect (4:3)
20	-	-
21	DAM:ZOOM	Aspect (ZOOM)
22	-	-
23	-	-
24	-	-
25	-	-
26	-	-
27	-	-
28	-	-
29	-	-
30	-	-
31	-	-
32	-	-
33	-	-
34	-	-
35	-	-
36	-	-
37	-	-
38	-	-
39	IMS:SL1	Input select (SLOT INPUT)
40	IMS:S1A	Input select (SLOT INPUT A)
41	IMS:S1B	Input select (SLOT INPUT B)
42	IMS:VD1	Input select (VIDEO)
43	IMS:YP1	Input select (COMPONENT)
44	IMS:HM1	Input select (HDMI)
45	IMS:DV1	Input select (DVI)
46	IMS:PC1	Input select (PC)
47	IMS:NW1	Input select (NETWORK)
48	-	-
49	-	-
50	-	-
51	-	-
52	-	-
53	-	-
54	-	-
55	OSP:SCR0	Screen Saver SCROLLING BAR ONLY (OFF)
56	OSP:SCR1	Screen Saver SCROLLING BAR ONLY (ON)
57	POF	Power OFF
58	PON	Power ON
59	SSC:FNC0	Screen Saver function (SCROLLING BAR ONLY)
60	SSC:FNC1	Screen Saver function (NEGATIVE IMAGE)
61	SSC:MOD0	Screen Saver (Mode (OFF))
62	SSC:MOD3	Screen Saver (Mode (ON))
63	VMT:0*	Picture Mute (OFF)
64	VMT:1*	Picture Mute (ON)

\* Picture Mute cannot be unlocked by powering off/on with the remote control. Turn off and on again with the button on the unit or enter the command VMT:0 to unlock Picture Mute.

# Specifications

	TH-60PF50U	TH-65PF50U
<b>Power Source</b>	110 - 127 V AC, 50/60 Hz	
<b>Power Consumption</b>		
Rated Power Consumption	515 W	555 W
Stand-by condition	0.4 W	0.4 W
Power off condition	0.2 W	0.2 W
<b>Plasma Display panel</b>	Drive method : AC type 60-inch, 16:9 aspect ratio	Drive method : AC type 65-inch, 16:9 aspect ratio
<b>Screen size</b>	52.3" (1,330 mm) (W) × 29.4" (748 mm) (H) × 60.1" (1,526 mm) (diagonal)	56.4" (1,434 mm) (W) × 31.7" (806 mm) (H) × 64.7" (1,645 mm) (diagonal)
(No. of pixels)	2,073,600 (1,920 (W) × 1,080 (H)) [5,760 × 1,080 dots]	
<b>Operating condition</b>		
Temperature	32 °F - 104 °F (0 °C - 40 °C)	
Humidity	20 % - 80 %	
<b>Applicable signals</b>		
Color System	NTSC, PAL, PAL60, SECAM, Modified NTSC	
Scanning format	525 (480) / 60i · 60p, 625 (575) / 50i · 50p, 750 (720) / 60p · 50p, 1125 (1080) / 60i · 60p · 50i · 50p · 24p · 25p · 30p · 24sF, 1250 (1080) / 50i	
PC signals	VGA, SVGA, XGA, SXGA UXGA ..... (compressed) Horizontal scanning frequency 15 - 110 kHz Vertical scanning frequency 48 - 120 Hz	
<b>Connection terminals</b>		
AV IN	VIDEO	BNC 1.0 Vp-p (75 Ω)
	AUDIO L-R	RCA Pin jack × 2 0.5 Vrms, Shared with COMPONENT/RGB IN
	HDMI	TYPE A Connector
COMPONENT/RGB IN	Y/G	BNC with sync 1.0 Vp-p (75 Ω)
	P <sub>B</sub> /C <sub>B</sub> /B	BNC 0.7 Vp-p (75 Ω)
	P <sub>R</sub> /C <sub>R</sub> /R	BNC 0.7 Vp-p (75 Ω)
	AUDIO L-R	RCA Pin jack × 2 0.5 Vrms, Shared with VIDEO
DVI-D IN		DVI-D 24 Pin Content Protection Stereo mini jack (M3) × 1 Compliance with DVI Revision 1.0 Compatible with HDCP 1.1 0.5 Vrms, Shared with PC IN
	AUDIO	
PC IN		High-Density Mini D-sub 15 Pin Y or G with sync 1.0 Vp-p (75 Ω) Y or G without sync 0.7 Vp-p (75 Ω) P <sub>B</sub> /C <sub>B</sub> /B: 0.7 Vp-p (75 Ω) P <sub>R</sub> /C <sub>R</sub> /R: 0.7 Vp-p (75 Ω) HD/VD: 1.0 - 5.0 Vp-p (high impedance) 0.5 Vrms, Shared with DVI-D IN
	AUDIO	Stereo mini jack (M3) × 1
SERIAL	External Control Terminal D-sub 9 Pin	RS-232C compatible
3D IR TRANSMITTER	for 3D IR TRANSMITTER (TY-3D30TRW)	
3D SHUTTER OUT	M3 jack × 1	
	DC 8V OUT Center plus, for EIAJ 4mm plug	
WIRELESS MODULE	for Wireless module (ET-WM200U)	
LAN	RJ45 10BASE-T/100BASE-TX, compatible with PLink™	
EXT SP	6 Ω, 16 W [8 W + 8 W] (10 % THD)	8 Ω, 20 W [10 W + 10 W] (10 % THD)
<b>Dimensions (W × H × D)</b>	56.5" (1,434 mm) × 33.6" (852 mm) × 3.9" (99 mm)	61.2" (1,554 mm) × 36.5" (925 mm) × 3.9" (99 mm)
<b>Mass (weight)</b>		
main unit only	approx. 108.1 lbs	approx. 132.3 lbs
with speakers	approx. 121.3 lbs	approx. 145.5 lbs

**Note:**

Design and specifications are subject to change without notice. Mass and dimensions shown are approximate.

**This product incorporates the following software:**

- (1) the software developed independently by or for Panasonic Corporation,
- (2) the software owned by third party and licensed to Panasonic Corporation,
- (3) the software licensed under the GNU General Public License, Version 2.0 (GPL-2.0),
- (4) the software licensed under the GNU LESSER General Public License, Version 2.1 (LGPL-2.1) and/or,
- (5) open source software other than the software licensed under the GPL and/or LGPL.

For the software categorized as (3) and (4), please refer to the terms and conditions of GPL-2.0 and LGPL-2.1, as the case may be at

<http://www.gnu.org/licenses/old-licenses/gpl-2.0.html> and  
<http://www.gnu.org/licenses/old-licenses/lgpl-2.1.html>

The GPL/LGPL software is distributed in the hope that it will be useful, but WITHOUT ANY WARRANTY, without even the implied warranty of MERCHANTABILITY or FITNESS FOR A PARTICULAR PURPOSE.

At least three (3) years from delivery of products, Panasonic will give to any third party who contact us at the contact information provided below, for a charge no more than our cost of physically performing source code distribution, a complete machine-readable copy of the corresponding source code and the copyright notice, covered under GPL-2.0/LGPL-2.1.

Contact Information

[oss-cd-request@gg.jp.panasonic.com](mailto:oss-cd-request@gg.jp.panasonic.com)

For the software categorized as (5) includes as follows.

- 1. The software developed by the OpenSSL Project for use in the OpenSSL Toolkit. (<http://www.openssl.org/>)
- 2. The software developed by the University of California, Berkeley and its contributors.
- 3. FreeType code.
- 4. The Independent JPEG Group's JPEG software.
- 5. tthttpd code.

**USA Only:**

Disposal may be regulated in your community due to environmental considerations. For disposal or recycling information, please visit Panasonic website:

<http://www.panasonic.com/environmental> or call 1-888-769-0149.

**Customer's Record**

The model number and serial number of this product can be found on its back cover. You should note this serial number in the space provided below and retain this book, plus your purchase receipt, as a permanent record of your purchase to aid in identification in the event of theft or loss, and for Warranty Service purposes.

Model Number \_\_\_\_\_

Serial Number \_\_\_\_\_

© Panasonic Corporation 2012

---

**Panasonic System Communications Company of North America**

Unit of Panasonic Corporation of North America

**Executive Office :**

Three Panasonic Way 2F-5, Secaucus, NJ 07094

**Panasonic Canada Inc.**

5770 Ambler Drive  
Mississauga, Ontario  
L4W 2T3