



Model H8088 2-Stage Transmission Jack

Specifications

Maximum Lifting Capacity 1,100 Lbs.
Lifting Range 34"–71 $\frac{3}{8}$ "
Weight 138 Lbs.

Assembly

Refer to the parts breakdown on the back of this page to understand how the jack is assembled.

Operation

Pump Control Handle (Figure 1): Point to the left to allow the jack platform to lift when pumped. Point to the right to lower the jack. (If the jack holds a heavy load, turn very slowly to control the lowering rate and avoid dropping the load.)

Foot Pedal Pump (Figure 1): When moved up and down, the foot pedal pump lifts the jack platform.

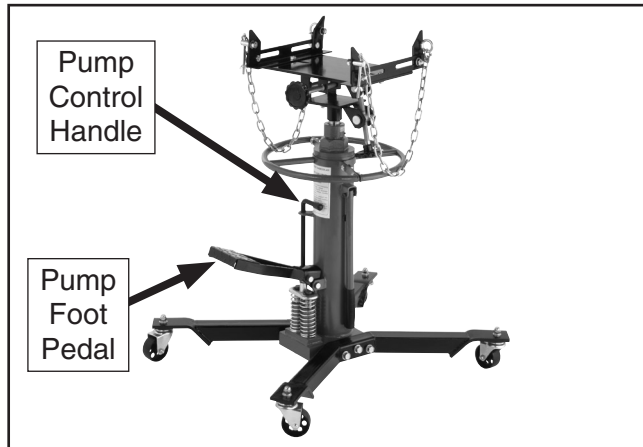

Figure 1. Pump controls.

Platform Adjustment Knobs (Figure 2): Located under the jack platform, these knobs allow for precision placement and leveling of the platform.



Figure 2. Platform adjustment knobs.

⚠ WARNING

This jack is designed to assist in transmission removal only. Failure to follow these instructions when using the transmission jack could result in serious personal injury or death:

1. ALWAYS support the vehicle with appropriately rated support stands before using this jack.
2. Only use this jack on hard level surfaces such as concrete or asphalt.
3. DO NOT overload this jack beyond the maximum lifting capacity. Overloading can cause the jack to collapse.
4. DO NOT use this jack to lift or support a vehicle.
5. Keep fingers and hands away from pinch points when lowering.
6. Only transport load with jack platform in the lowered position.
7. Center the load on the jack for stability and use safety chain to secure load.

If you need help with the Model H8088, call our Technical Support line at: (570) 546-9663.

Maintenance

The Model H8088 will require hydraulic fluid after long-term use. This will be noticeable if the jack will not reach its maximum height.

To add hydraulic fluid, Remove the fill bolt, shown in **Figure 3**, and add fluid until it reaches the top of the fill bolt hole.

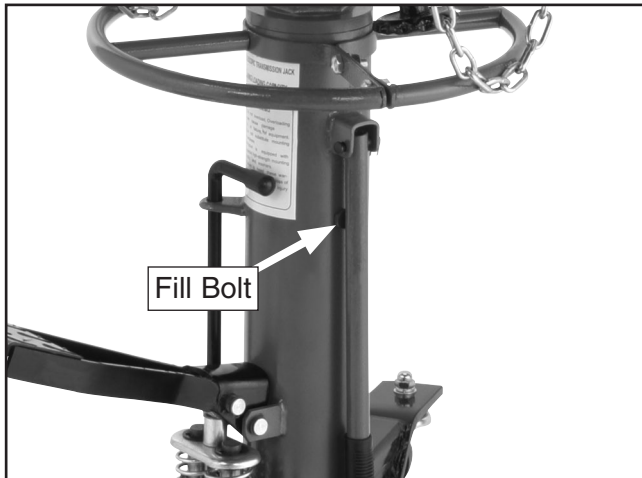

Figure 3. Fill bolt.

Keep the hydraulic rams clean and free of any dust, dirt, or foreign debris. Abrasive material stuck to the ram can damage the hydraulic seal when the ram is retracted back into the jack. Regularly wipe the hydraulic rams clean with a lightly oiled rag.

Bleeding the Pump

If the jack becomes spongy or will not rise when pumped, then air bubbles may be in the hydraulic system. These can be removed by using the air release set screw shown in **Figure 4**.

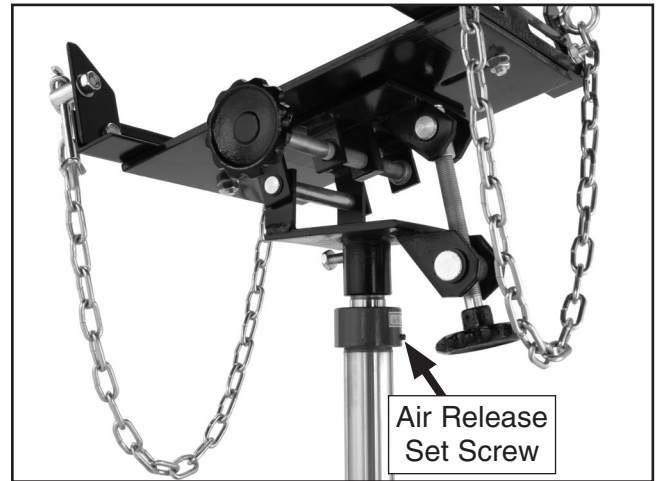
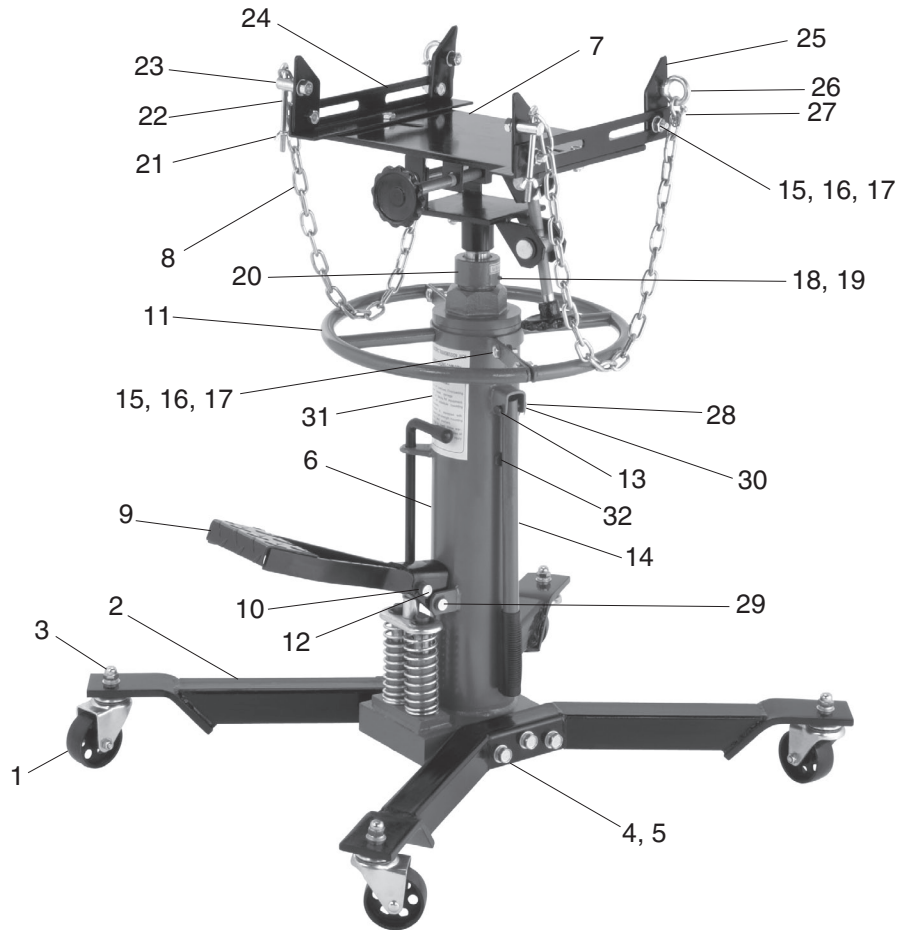

Figure 4. Air

To remove the air bubbles:

1. Hold a rag under the air release set screw.
2. Pump the foot pedal a couple times, then hold it down and loosen the set screw until air bubbles and fluid comes out. When the air bubbles and fluid stops coming out, tighten the set screw.
3. Repeat **Step 2** as many times as needed until the air bubbles stop coming out in the hydraulic fluid.

H8088 Parts Breakdown and List



REF	PART #	DESCRIPTION
1	PH8088001	CASTER
2	PH8088002	LEG
3	PN09M	HEX NUT M12-1.75
4	PLW05M	LOCK WASHER 12MM
5	PB140M	HEX BOLT M12-1.75 X 70
6	PH8088006	PUMP ASSEMBLY
7	PH8088007	PLATFORM ASSEMBLY
8	PH8088008	CHAIN
9	PH8088009	FOOT PEDAL
10	PR06M	EXT RETAINING RING 16MM
11	PH8088011	HALF CIRCLE HANDLE
12	PH8088012	FOOT PEDAL PIN 66MM
13	PH8088013	HANDLE PIN
14	PH8088014	STRAIGHT HANDLE
15	PB32M	HEX BOLT M10-1.5 X 25
16	PW04M	FLAT WASHER 10MM

REF	PART #	DESCRIPTION
17	PN02M	HEX NUT M10-1.5
18	PH8088018	STEEL BALL 5MM
19	PSS01M	SET SCREW M6-1 X 10
20	PH8088020	COLLAR
21	PWN02M	WING NUT M8-1.25
22	PH8088022	HOOK BOLT
23	PH8088023	STUD PIN
24	PH8088024	ANGLE IRON PIECE
25	PH8088025	CORNER METAL PIECE
26	PH8088026	EYE BOLT
27	PH8088027	ANCHOR SHACKLE W/SCREW
28	PH8088028	COTTER PIN 3 X 35
29	PH8088029	PIN 76MM
30	PW01M	FLAT WASHER 8MM
31	PH8088031	MACHINE ID LABEL
32	PH8088032	FILL BOLT

WARNING

The machine ID label warns about hazards and ways to prevent injury. The owner of the jack **MUST** maintain the original location and readability of the label. If the label is removed or becomes unreadable, contact Grizzly at (800) 523-4777 or www.grizzly.com to order a new label.

grizzly.com

TOOL WEBSITE

Buy Direct and Save with Grizzly® – Trusted, Proven and a Great Value!

*Visit Our Website Today And Discover
Why Grizzly® Is The Industry Leader!*

- SECURE ORDERING
- ORDERS SHIPPED WITHIN 24 HOURS
- E-MAIL RESPONSE WITHIN ONE HOUR

-OR-

Call Today For A **FREE**
Full Color Catalog

1-800-523-4777

