

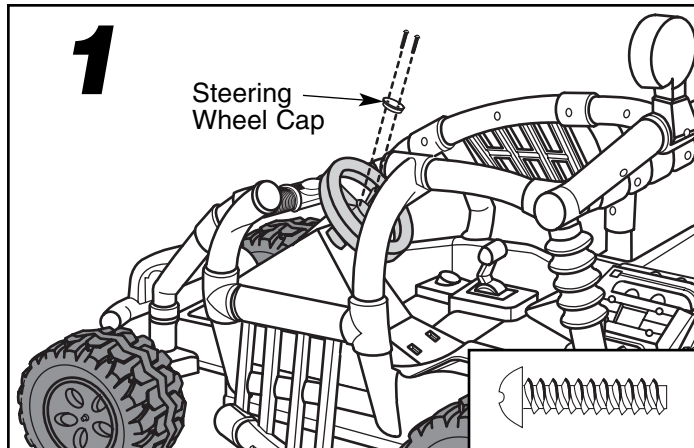

Steering Column Replacement Kit

Model Number: 73180

Tools needed for replacement: Phillips Screwdriver and Pliers (not included).



- Remove the label on the steering wheel cap.
- Loosen and remove the two #8 x 3/4" screws in the steering wheel cap with a Phillips screwdriver.
- Remove the steering wheel cap.
- Set the screws and the steering wheel cap aside for step 7.

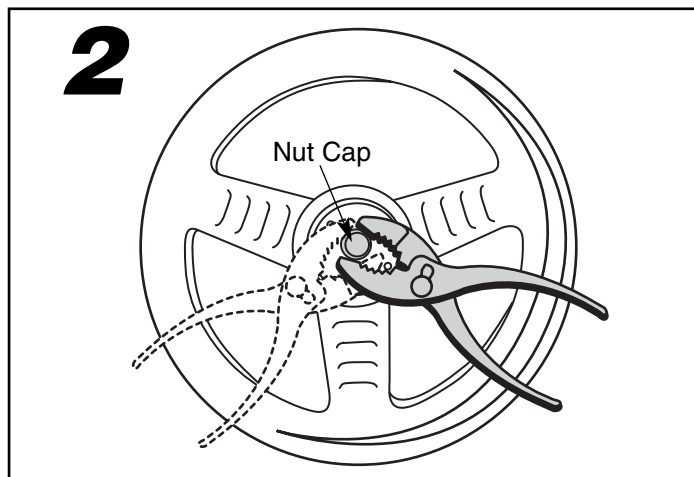

Note: When removing the cap nut from the old steering column, you will crush it. We have included a new cap nut in this kit for re-assembly.

To remove the cap nut from the old steering column:

- Squeeze the cap nut on the steering column with pliers.
- Now, at a different angle, squeeze the cap nut again with the pliers.
- Remove the crushed cap nut from the old steering column and throw it away.

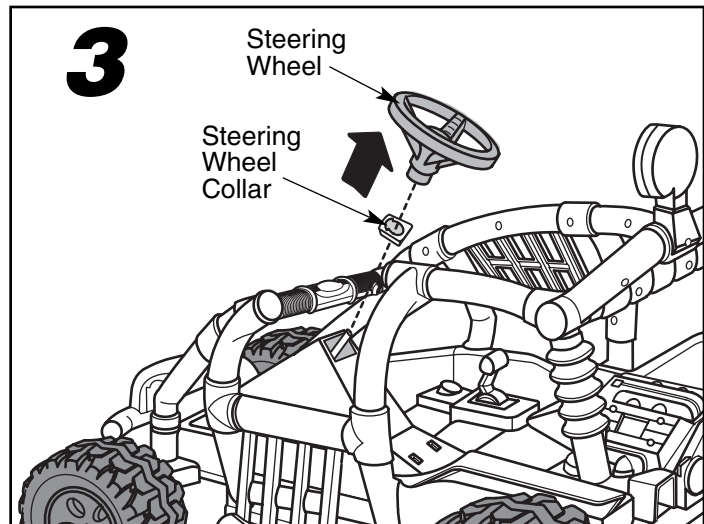

- Remove the steering wheel and steering wheel collar from the old steering column.

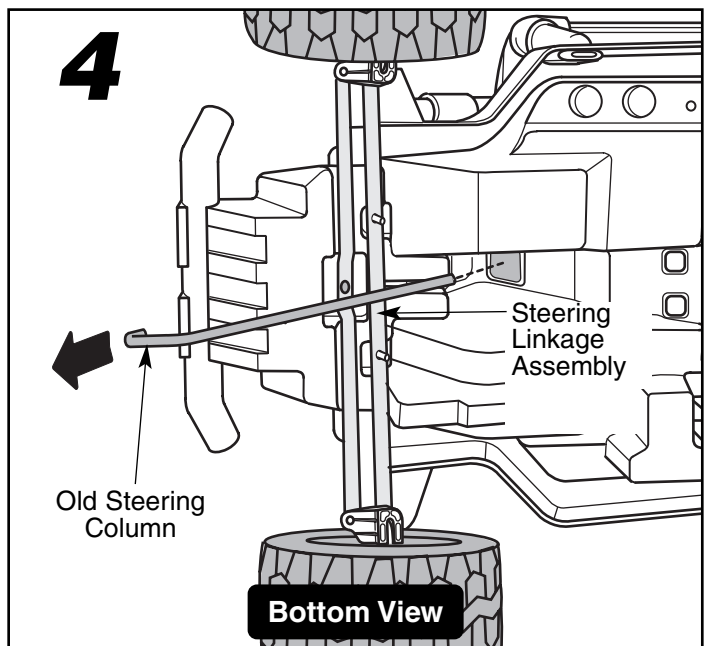

- Turn the vehicle on it's side.
- Remove the old steering column from the steering linkage assembly and the vehicle body.
- Throw away the old steering column.

Fisher-Price and Power Wheels by Fisher-Price are U.S. trademarks of Mattel, Inc. Fisher-Price, Inc., a subsidiary of Mattel, Inc., East Aurora, New York 14052 U.S.A. ©2001 Mattel, Inc. All Rights Reserved.

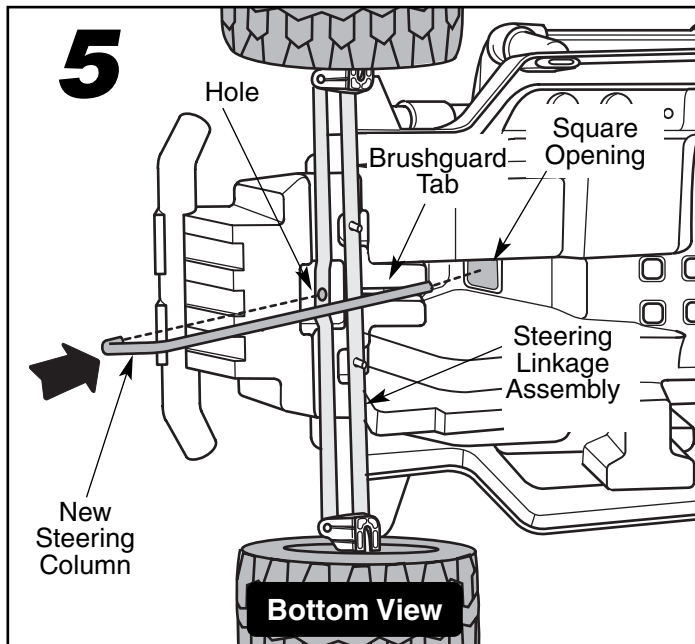

- Insert the straight end of the **new** steering column up through the square opening in the vehicle body.
- Fit the curved end of the steering column into the hole in the steering linkage assembly. The steering column will fit snugly into the slot in the brushguard tab.

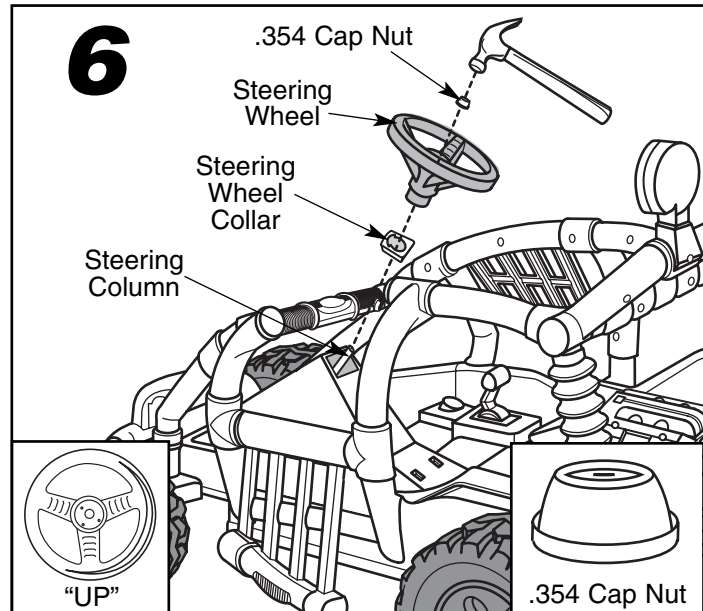

- While holding the steering column in place, position the vehicle body upright.
- Push up on the end of the steering column to center it in the vehicle body opening.
- Fit the steering wheel collar over the end of the steering column and press the collar into the opening in the vehicle body.
- Position the steering wheel upright so that the spokes form a "Y".
- Fit the steering wheel onto the steering column. Make sure the base of the steering wheel fits into the steering wheel collar.
- Fit a .354 cap nut on the end of the steering column.
- Support the end of the steering column near the steering linkage assembly and tap the cap nut with a hammer to secure it. Pull on the steering wheel to make sure the cap nut is secure.

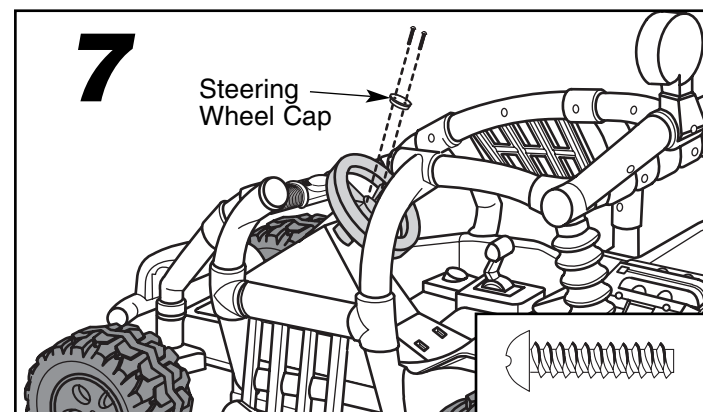

- Fit the steering wheel cap into the center of the steering wheel.
- Insert two #8 x 3/4" screws into the steering wheel cap.
- Tighten the screws with a Phillips screwdriver. Do not over-tighten.
- Place the new label on the steering wheel cap.

Replacement is now complete.

If you have further questions about your Power Wheels® vehicle or the replacement of the steering column, please call our toll-free service lines at 1-800-348-0751 from 8 AM to 6 PM (EST) Monday through Friday.