

0D9727
GENERAC®
POWER SYSTEMS, INC.

7.5 LITER

D I E S E L

ENGINE
PARTS
MANUAL

7.5L DIESEL TABLE OF CONTENTS

QUICK REFERENCE GUIDE	2
SERVICE RECOMMENDATIONS	4
CYLINDER HEAD ASSEMBLY	8
CYLINDER BLOCK ASSEMBLY	9
LINER AND PISTON KIT	10
CRANKSHAFT ASSEMBLY	11
ROCKER COVER AND BREATHER	12
CYLINDER HEAD	13
CYLINDER BLOCK	14
OIL PAN ASSEMBLY	16
ENGINE GASKET KIT	17
FLYWHEEL AND HOUSING	18
PISTON AND CONNECTING ROD	20
CRANKSHAFT	21
CAMSHAFT AND VALVE	22
TIMING GEAR	24
ATTACHING PARTS	26
OIL PUMP AND STRAINER	28
OIL FILTER	30
OIL COOLER	31
OIL LINE	32
FUEL FILTER AND HOSE	34
FUEL INJECTION PUMP	36
INJECTION PIPE	38
INJECTION NOZZLE	40
FUEL RETURN HOSE	42
ENGINE MOUNTING AND SUPPORT	43
WATER PUMP AND FAN	44
WATER PIPE AND THERMOSTAT	45
INTAKE MANIFOLD	46
EXHAUST MANIFOLD	47
TURBOCHARGER	48
EXHAUST PIPE	49
STARTER	50
ALTERNATOR	51
ENGINE COMMON PARTS	52
ELECTRONIC GOVERNOR	54
AIR CLEANER	55

LEGEND

“AR” AS REQUIRED
(STD) STANDARD SIZE
“O.S.” OVERSIZE
“U.S.” UNDERSIZE

NOTICE!

THE INFORMATION IN THIS MANUAL IS KNOWN TO BE ACCURATE AS OF THE DATE OF RELEASE SHOWN ON THE COVER. HOWEVER, ENGINEERING CHANGES CAN OCCUR WITHOUT NOTICE. TO OBTAIN THE PROPER PARTS, PLEASE BE SURE TO USE THE MODEL NUMBER OF THE UNIT BEING SERVICED WHEN ORDERING FROM THIS MANUAL.

7.5L DIESEL QUICK REFERENCE GUIDE

SPECIFICATIONS:

CRANKCASE OIL CAPACITY:

6.0 U.S. GALLONS (22.7 LITERS)

COOLING SYSTEM CAPACITY:

11.2 U.S. GALLONS (42.4 LITERS)

RECOMMENDED FLUIDS

COOLANT:

USE A 50/50 MIXTURE OF LOW SILICATE ETHYLENE GLYCOL BASE ANTI-FREEZE AND SOFT WATER. (IF DESIRED, A HIGH QUALITY RUST INHIBITOR MAY BE ADDED TO THE RECOMMENDED COOLANT MIXTURE.) WHEN ADDING COOLANT, ALWAYS ADD THE RECOMMENDED 50/50 MIXTURE.

ENGINE OIL:

USE A HIGH QUALITY DETERGENT OIL HAVING AAPI CLASSIFICATION "FOR SERVICE CC OR CD." THE SAE VISCOSITY RATING OF THE OIL SHOULD BE CAREFULLY SELECTED, BASED ON THE PREVAILING AMBIENT TEMPERATURE RANGE ANTICIPATED BEFORE THE NEXT OIL CHANGE. RECOMMENDED SAE VISCOSITY GRADES ARE AS FOLLOWS:

TEMPERATURE	RECOMMENDED OIL GRADE
ABOVE 90°F	SAE 40
32°F TO 90°F	SAE 30
12°F TO 32°F	SAE 20

7.5L DIESEL QUICK REFERENCE GUIDE

QUICK REFERENCE ENGINE PARTS

PART NUMBER	DESCRIPTION	QTY
0D57030309	OIL FILTER	1
090625	AIR FILTER	1
0D57030353	FUEL FILTER	1
0D57030416	WATER PUMP	1
0D57030468	ALTERNATOR	1
0D57030463	STARTER	1
0D57030436	THERMOSTAT & GASKET KIT	1
0D57030424	ALTERNATOR BELT	1
0D57030106	ENGINE OVERHAUL GASKET KIT	AR

7.5L DIESEL SERVICE RECOMMENDATIONS

40 KW - 400 KW STANDBY DIESEL ENGINE DRIVEN GENERATOR SETS

Following is a recommended maintenance schedule for Generac standby diesel engine driven generator sets from 40 kW to 400 kW in size. The established intervals in the schedule are the *maximum* recommended when the unit is used in an average service application. They will need to be decreased (performed more frequently) if the unit is used in a severe application. Use the unit hour meter or calendar time, whichever occurs first, from the previous maintenance interval to determine the next required maintenance interval.

Service Maintenance Interval Information:

The various service maintenance intervals are designated by interval numbers as follows:

- 1 An early inspection of the generator set to insure it is ready to operate when required and to identify any potential problem areas.

Performed monthly or following each 10 hours of operation of the unit and requires approximately .5 man-hours per unit to complete.

This inspection may be performed by the end user providing the following safety steps are taken to prevent the engine from starting automatically without warning:

To prevent injury, perform the following steps in the order indicated before starting any maintenance:

- **Disable the generator set from starting and/or connecting to the load by setting the control panel Auto-Off-Manual switch to the "OFF" position.**
- **Remove the control panel fuse.**
- **Turn off the battery charger.**
- **Remove the negative battery cable.**

The battery charger must be turned off BEFORE removing the battery cable to prevent an over current condition from burning out sensitive control panel components and circuits.

Following all maintenance, reverse these steps to insure the unit is returned to standby setup for normal operation when required.

- 2 A break-in service inspection of the generator set to insure it is ready to operate and carry the load when required, and to identify any potential problem areas.

*Performed **ONLY ONCE** following the first three months or the first 30 hours of operation after purchase of the unit and requires approximately 2.5 man-hours per unit to complete.*

This inspection contains some maintenance tasks which require special tools, equipment, and/or knowledge to accomplish and should be performed only by an authorized Generac Service Dealer.

- 3 An operational inspection of the generator set to insure it is ready to operate and carry the load when required, and to identify any potential problem areas.

Performed semi-annually or following each 50 hours of operation of the unit and requires approximately 1.5 man-hours per unit to complete.

This inspection contains some maintenance tasks which require special tools, equipment, and/or knowledge to accomplish and should be performed only by an authorized Generac Service Dealer.

- 4 A mid-level inspection of the generator set to insure it is ready to operate and carry the load when required, and to identify any potential problem areas.

Performed annually or following each 100 hours of operation of the unit and requires approximately 5.0 man-hours per unit to complete.

This inspection contains some maintenance tasks which require special tools, equipment, and/or knowledge to accomplish and should be performed only by an authorized Generac Service Dealer.

NOTE: Add 20% to all times for 8 cylinder or larger engines.

GENERAC POWER SYSTEMS, INC.

RECOMMENDED SCHEDULED MAINTENANCE PROGRAM SERVICE WORK TO BE PERFORMED BY FACTORY-TRAINED PERSONNEL ONLY.

DEALER INFORMATION

NAME: _____
ACCOUNT #: _____
ADDRESS: _____

PHONE: _____
TECHNICIAN: _____
SIGNATURE: _____

OWNER INFORMATION

NAME: _____
ADDRESS: _____

SITE: _____
PHONE: _____
SIGNATURE: _____

PURCHASE DATE: _____ START-UP DATE: _____

APPLICATION: ___ Standby Power ___ Prime Power ___ Rental/Trailerized

GENERATOR & TRANSFER SWITCH INFORMATION

GENERATOR

MODEL NUMBER: _____
SERIAL NUMBER: _____

TRANSFER SWITCH

MODEL NUMBER: _____
SERIAL NUMBER: _____

HOUR METER READING *at Completion of the Inspection*: _____

WARNING!

To prevent injury, perform the following steps in the order indicated before starting any maintenance:

- Disable the generator set from starting and/or connecting to the load by setting the control panel Auto-Off-Manual switch to the "OFF" position.
- Remove the control panel fuse.
- Turn off the battery charger.
- Remove the negative battery cable.

NOTE:

















The battery charger must be turned off BEFORE removing the battery cable to prevent an over current condition from burning out sensitive control panel components and circuits.

Following all maintenance, reverse these steps to insure the unit is returned to standby setup for normal operation when required.

7.5L DIESEL SERVICE RECOMMENDATIONS

Maintenance Tasks	Level 1	Task Comp. (Date-Initials)	Level 2	Task Comp. (Date-Initials)	Level 3	Task Comp. (Date-Initials)	Level 4	Task Comp. (Date-Initials)
	Recommended to be done monthly/ 10 hrs.		Required to be done 3 months/ Break-in 30 hrs.		Required to be done Semi-annually/ 50 hrs.		Required to be done Annually/ 100 hrs.	
1. Disable the unit from operating per the first page warning.	○		○		○		○	
2. Check the engine oil level. Adjust as necessary.	○		○		○		○	
3. Check the engine coolant level. Adjust as necessary.	○		○		○		○	
4. Check the engine coolant thermal protection level. Correct as necessary.							○	
5. Check the diesel fuel supply level. Fill as necessary.	○		○		○		○	
6. Drain water and sediment from the diesel fuel tank.			○		○		○	
7. Drain water from the fuel line water separator if the unit is equipped with one.			○		○		○	
8. Check the air inlets and outlets for debris. Clean as necessary.	○		○		○		○	
9. Check the battery electrolyte level if accessible. Adjust as necessary.	○		○		○		○	
10. Check the battery posts, cables, and charger for loose connections, corrosion, and proper operation. Correct as necessary.	○		○		○		○	
11. Check the unit wiring for loose connections, corrosion, and damage. Correct as necessary.							○	
12. Check the engine accessory drive belts for wear, weather cracking, and damage. Replace as necessary.							○	
13. Visually inspect the unit looking for leaks, wear or damage, loose connections or components, and corrosion. Correct as necessary.	○		○		○		○	
14. Test the engine and transfer switch safety devices. Correct and/or adjust as necessary.							○	

7.5L DIESEL SERVICE RECOMMENDATIONS

Maintenance Tasks	Level 1 Recom- mended to be done monthly/ 10 hrs.	Task Comp. (Date- Initials)	Level 2 Required to be done 3 months/ Break-in 30 hrs.	Task Comp. (Date- Initials)	Level 3 Required to be done Semi- annually/ 50 hrs.	Task Comp. (Date- Initials)	Level 4 Required to be done Annually/ 100 hrs.	Task Comp. (Date- Initials)
15. Initiate an automatic start and transfer of the unit to site load and exercise it for at least 1 hour looking for leaks, loose connections or components, and abnormal operating conditions. Correct as necessary.								
16. Start and exercise the unit at full rated load (use a load bank if the site load is not enough) for at least 2 hours looking for leaks, loose connections or components, and abnormal operating conditions. Correct as necessary.								
17. Change the engine oil.								
18. Replace the engine oil filter(s).								
19. Replace the engine fuel filter(s) and re-prime the fuel system.								
20. Replace the engine air filter(s).								
21. Perform a 5 minute no-load operational run of the unit looking for any post service problems.								
22. Return the unit to standby setup for operation when required.								

7.5L DIESEL — CYLINDER HEAD ASSEMBLY

01200A

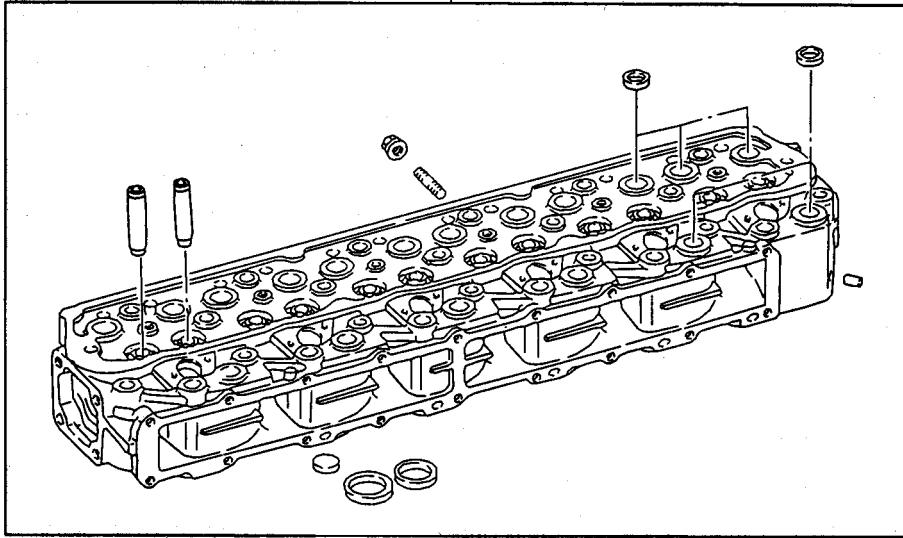

ITEM	PART NUMBER	DESCRIPTION	QTY
01200A	0D57030100	CYLINDER HEAD ASSY	1

7.5L DIESEL — CYLINDER BLOCK ASSEMBLY

01300A

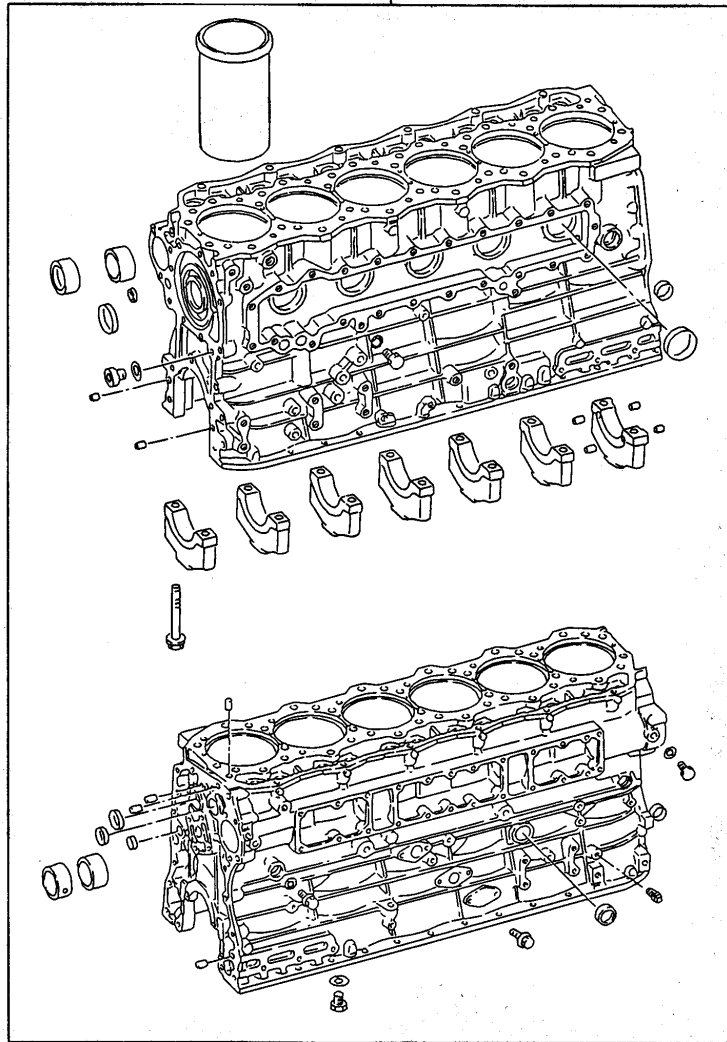

ITEM	PART NUMBER	DESCRIPTION	QTY
01300A	0D57030101	CYLINDER BLOCK ASSY	1

7.5L DIESEL — LINER AND PISTON KIT

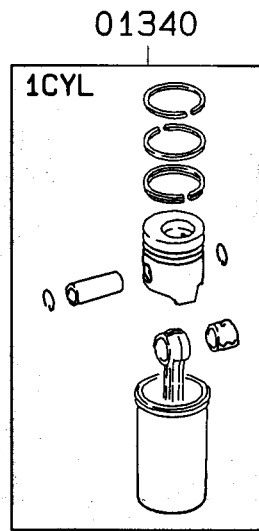

ITEM	PART NUMBER	DESCRIPTION	QTY
01340	0D57030102	LINER AND PISTON KIT (SIZE 1)	AR
	0D57030103	LINER AND PISTON KIT (SIZE 2)	AR
	0D57030104	LINER AND PISTON KIT (SIZE 3)	AR

7.5L DIESEL — CRANKSHAFT ASSEMBLY

03000A

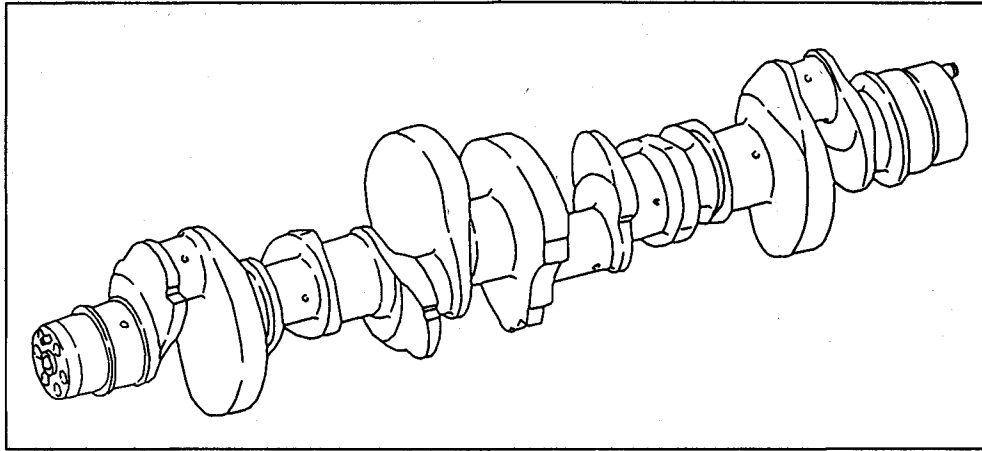

ITEM	PART NUMBER	DESCRIPTION	QTY
03000A	0D57030105	CRANKSHAFT ASSY	1

7.5L DIESEL — ROCKER COVER AND BREATHER

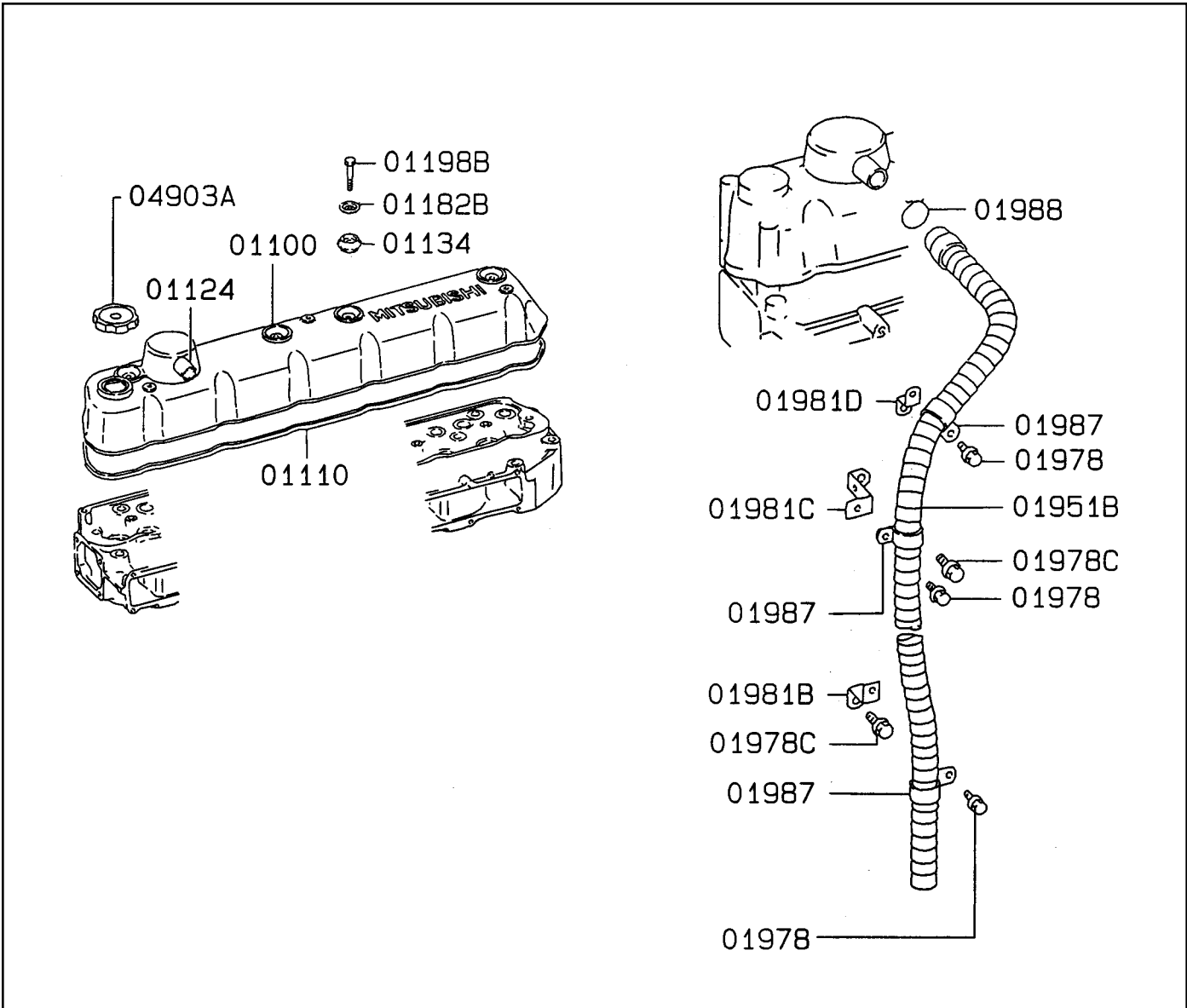

ITEM	PART NUMBER	DESCRIPTION	QTY
01100	0D57030107	COVER, ROCKER	1
01110	0D57030108	GASKET, ROCKER COVER	1
01124	0D57030109	JOINT, ROCKER COVER BREATHER HOSE	1
01134	0D57030110	SEAL, ROCKER COVER BOLT	4
01182B	0D57030111	WASHER, ROCKER COVER	4
01198B	0D57030112	BOLT, ROCKER COVER	4
01951B	0D57030113	HOSE, ENGINE BREATHER	1
01978	0D57030114	BOLT, ENGINE BREATHER	3
01978C	0D57030115	BOLT, ENGINE BREATHER	2
01981B	0D57030116	STAY, ENGINE BREATHER	1
01981C	0D57030117	STAY, ENGINE BREATHER	1
01981D	0D57030118	STAY, ENGINE BREATHER	1
01987	0D57030119	CLIP, ENGINE BREATHER	3
01988	0D57030120	CLAMP, ENGINE BREATHER	1
04903A	0D57030121	CAP ASSY, OIL FILLER	1

7.5L DIESEL — CYLINDER HEAD

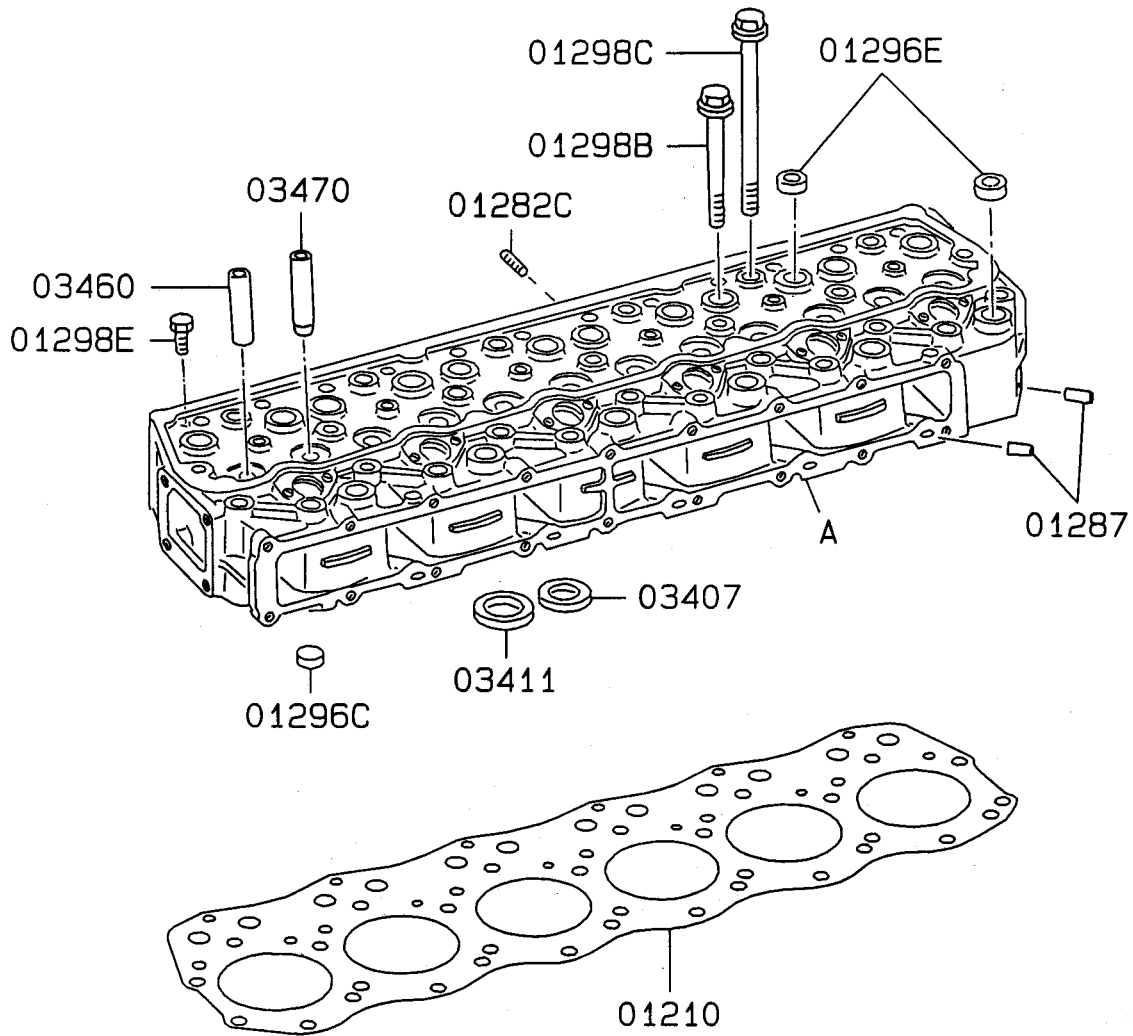

ITEM	PART NUMBER	DESCRIPTION	QTY
01210	0D57030122	GASKET, CYLINDER HEAD	1
01282C	0D57030123	STUD, CYLINDER HEAD	12
01287	0D57030124	PLUG, CYLINDER HEAD	6
01296C	0D57030125	CAP, CYLINDER HEAD	5
01296E	0D57030126	CAP, CYLINDER HEAD	18
01298B	0D57030127	BOLT, CYLINDER HEAD	20
01298C	0D57030128	BOLT, CYLINDER HEAD	6
01298E	0D57030129	BOLT, CYLINDER HEAD	6
03407	0D57030130	SEAT, EXHAUST VALVE	6
03411	0D57030131	SEAT, INLET VALVE	6
03460	0D57030132	GUIDE, INLET VALVE	6
03470	0D57030133	GUIDE, EXHAUST VALVE	6

7.5L DIESEL — CYLINDER BLOCK

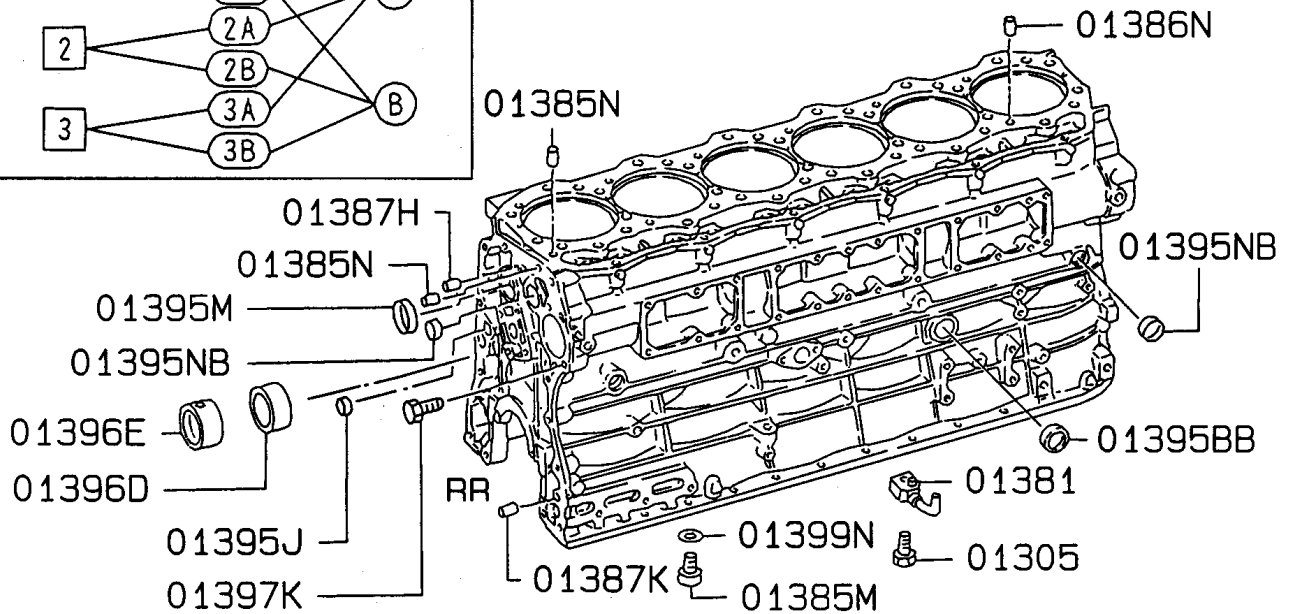
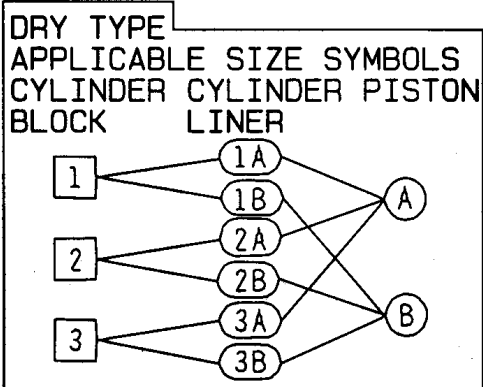
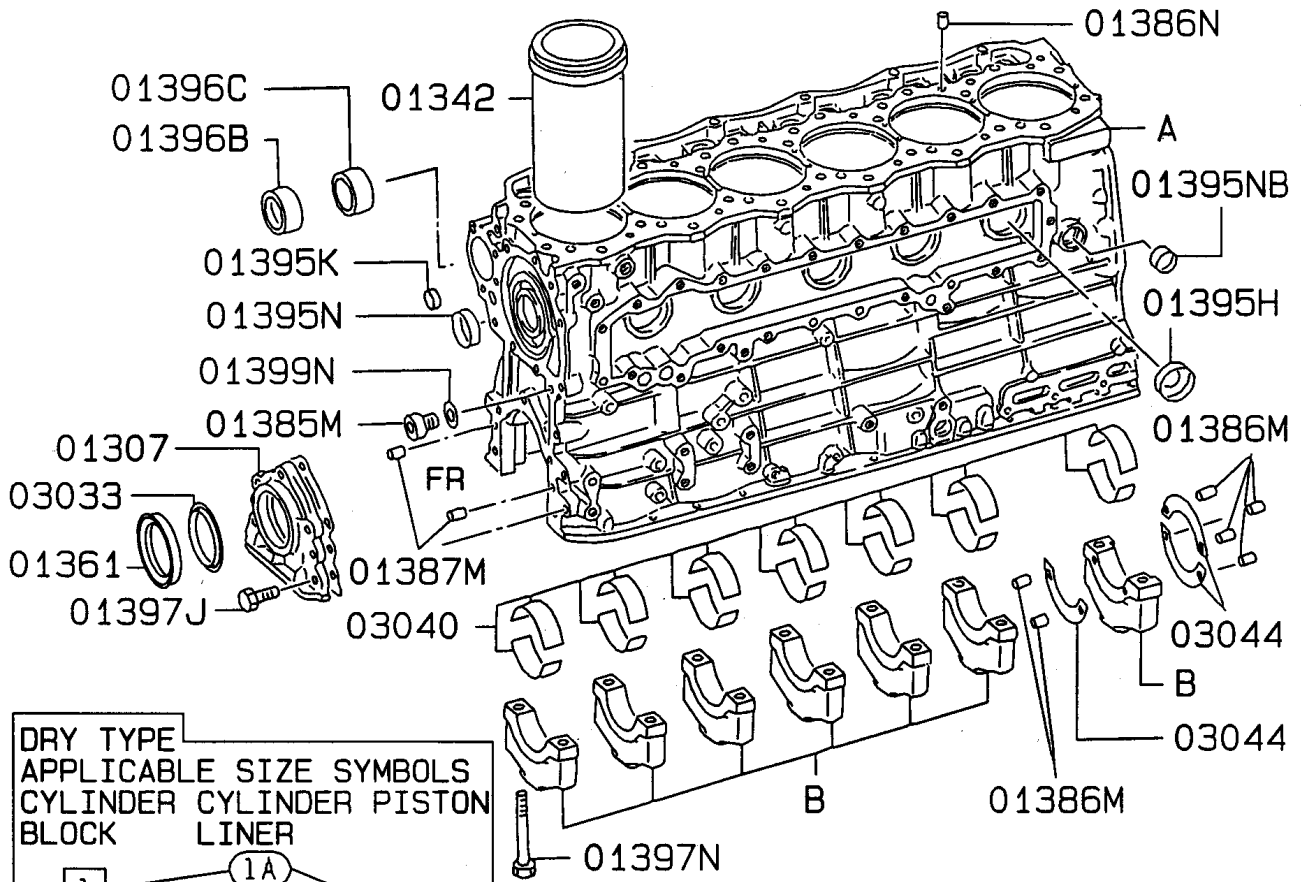

7.5L DIESEL — CYLINDER BLOCK

ITEM	PART NUMBER	DESCRIPTION	QTY
01305	0D57030134	CHECK VALVE	6
01307	0D57030135	COVER, CYLINDER BLOCK	1
01342	0D57030136	CYLINDER LINER (SIZE 1)	AR
	0D57030137	CYLINDER LINER (SIZE 2)	AR
	0D57030138	CYLINDER LINER (SIZE 3)	AR
01361	0D57030139	OIL SEAL, CYLINDER BLOCK FR COVER	1
01381	0D57030140	OIL JET, CYLINDER BLOCK	6
01385M	0D57030141	PLUG, CYLINDER BLOCK	2
01385N	0D57030142	PLUG, CYLINDER BLOCK	3
01386M	0D57030143	SPRING PIN, CYLINDER BLOCK	6
01386N	0D57030144	SPRING PIN, CYLINDER BLOCK	2
01387H	0D57030145	PIN, CYLINDER BLOCK	1
01387K	0D57030146	PIN, CYLINDER BLOCK	1
01387M	0D57030147	PIN, CYLINDER BLOCK	2
01395BB	0D57030148	CAP, CYLINDER BLOCK	1
01395H	0D57030149	CAP, CYLINDER BLOCK	5
01395J	0D57030150	CAP, CYLINDER BLOCK	1
01395K	0D57030151	CAP, CYLINDER BLOCK	1
01395M	0D57030152	CAP, CYLINDER BLOCK	1
01395N	0D57030153	CAP, CYLINDER BLOCK	1
01395NB	0D57030154	CAP, CYLINDER BLOCK	9
01396B	0D57030155	BUSHING, CYLINDER BLOCK	1
01396C	0D57030156	BUSHING, CYLINDER BLOCK	1
01396D	0D57030157	BUSHING, CYLINDER BLOCK	1
01396E	0D57030158	BUSHING, CYLINDER BLOCK	1
01397J	0D57030159	BOLT, CYLINDER BLOCK	5
01397K	0D57030160	BOLT, CYLINDER BLOCK	5
01397N	0D57030161	BOLT, CYLINDER BLOCK	14
01399N	0D57030162	GASKET, CYLINDER BLOCK	2
03033	0D57030163	OIL SLINGER, CRANKSHAFT, FR	1
03040	0D57030164	BEARING SET, CRANKSHAFT STD	1
	0D57030165	BEARING SET, CRANKSHAFT U/S 0.25	AR
	0D57030166	BEARING SET, CRANKSHAFT U/S 0.50	AR
	0D57030167	BEARING SET, CRANKSHAFT U/S 0.75	AR
	0D57030168	BEARING SET, CRANKSHAFT U/S 1.00	AR
03044	0D57030169	PLATE, CRANKSHAFT THRUST STD	3
	0D57030170	PLATE, CRANKSHAFT THRUST O/S 0.15	AR
	0D57030171	PLATE, CRANKSHAFT THRUST O/S 0.30	AR
	0D57030172	PLATE, CRANKSHAFT THRUST O/S 0.45	AR

7.5L DIESEL — OIL PAN ASSEMBLY

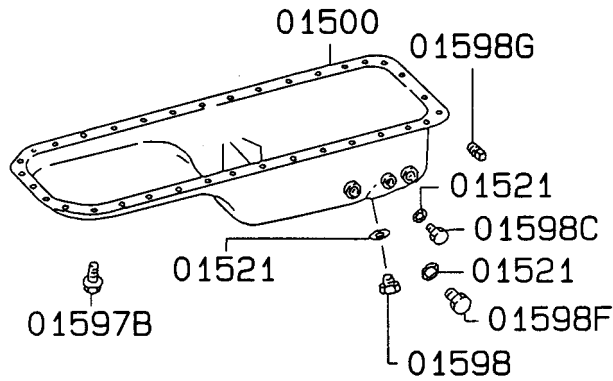
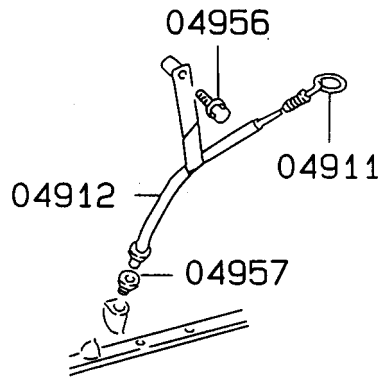

ITEM	PART NUMBER	DESCRIPTION	QTY
01500	0D57030173	OIL PAN, ENGINE	1
01521	0D57030174	GASKET, ENGINE OIL PAN DRAIN PLUG	3
01597B	0D57030175	BOLT, ENGINE OIL PAN	35
01598	0D57030176	PLUG, ENGINE OIL PAN	1
01598C	0D57030177	PLUG, ENGINE OIL PAN	1
01598F	0D57030178	PLUG, ENGINE OIL PAN	1
01598G	0D57030179	PLUG, ENGINE OIL PAN	1
04911	0D57030475	GAUGE, OIL LEVEL	1
04912	0D57030476	GUIDE, OIL LEVEL GAUGE	1
04956	0A45310210	BOLT, OIL FILLER	1
04957	0D57030477	BUSHING, OIL FILLER	1

7.5L DIESEL — ENGINE GASKET KIT

01070

The part number of engine overhaul gasket kit is that of the kit used for the standard engine. Please note that if the engine is provided with equipment other than the standard one, there is a kit component shortage or overage.

ITEM	PART NUMBER	DESCRIPTION	QTY
01070	0D57030106	ENGINE OVERHAUL GASKET KIT	AR

7.5L DIESEL — FLYWHEEL AND HOUSING

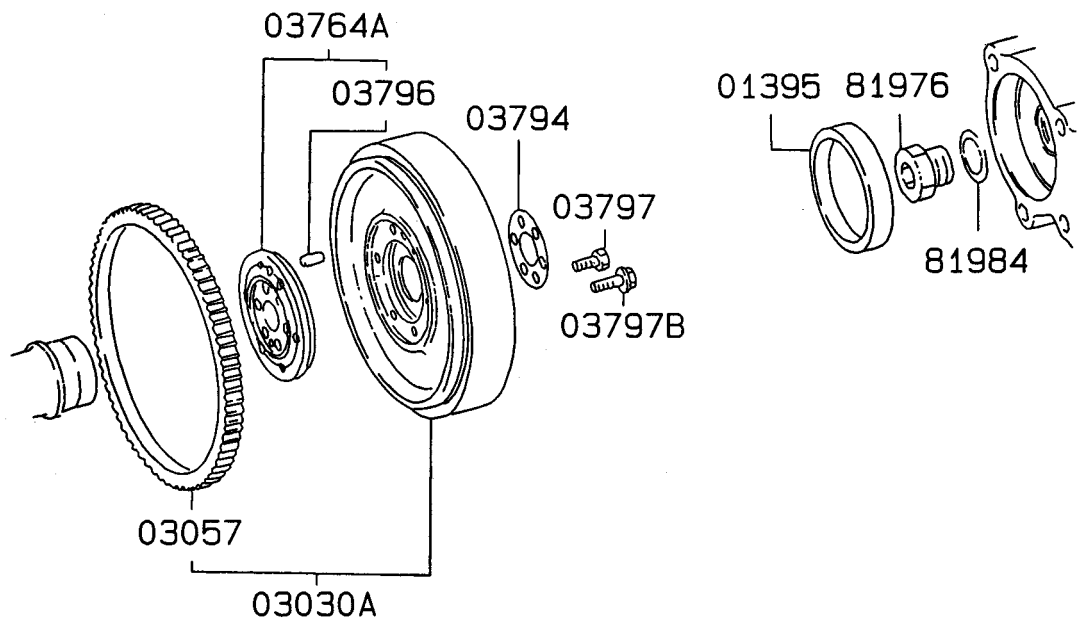
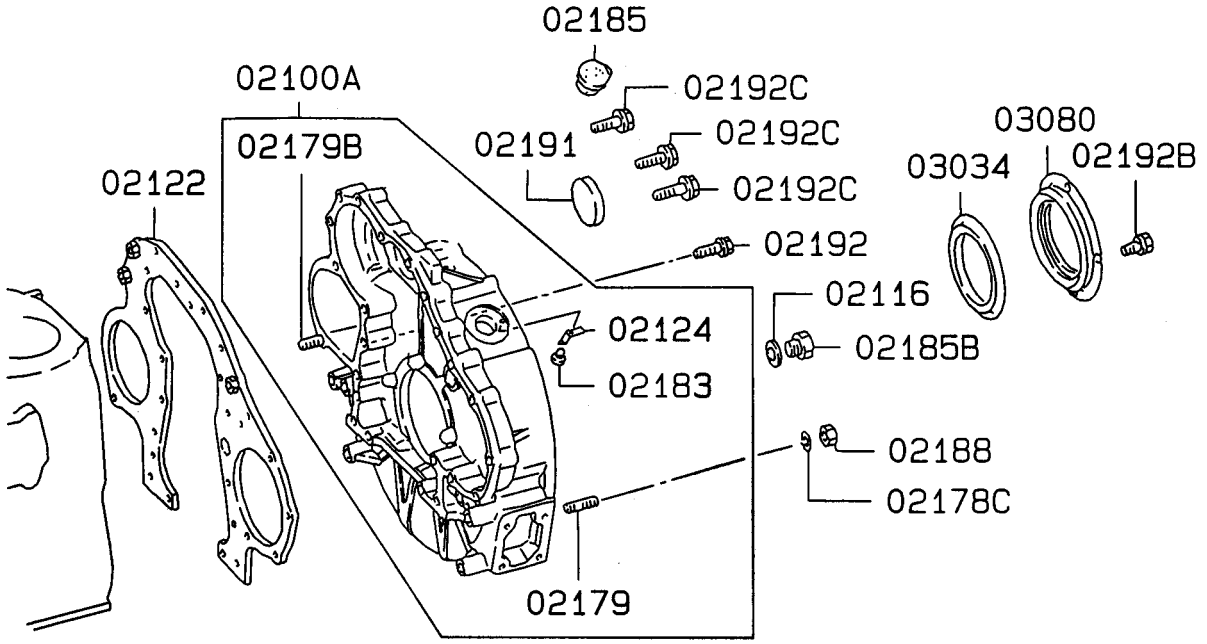

7.5L DIESEL — FLYWHEEL AND HOUSING

ITEM	PART NUMBER	DESCRIPTION	QTY
01395	0D57030180	CAP, CYLINDER BLOCK	1
02100A	0D57030181	HOUSING ASSY, FLYWHEEL	1
02116	0D57030174	GASKET, FLYWHEEL HOUSING	1
02122	0D57030182	PLATE, CYLINDER BLOCK, RR	1
02124	0D57030183	POINTER, FLYWHEEL HOUSING ENG TIMING	1
02178C	0D57030184	WASHER, FLYWHEEL HOUSING	12
02179	0D57030185	STUD, FLYWHEEL HOUSING	12
02179B	0D57030186	STUD, FLYWHEEL HOUSING	1
02183	0D57030187	SCREW, FLYWHEEL HOUSING	1
02185	0D57030188	PLUG, FLYWHEEL HOUSING	1
02185B	0D57030178	PLUG, FLYWHEEL HOUSING	1
02188	0D57030189	NUT, FLYWHEEL HOUSING	12
02191	0D57030190	CAP, FLYWHEEL HOUSING	1
02192	0D57030191	BOLT, FLYWHEEL HOUSING	8
02192B	0D57030192	BOLT, FLYWHEEL HOUSING	5
02192C	0D57030193	BOLT, FLYWHEEL HOUSING 10 x 50	1
	0D57030194	BOLT, FLYWHEEL HOUSING 10 x 55	5
	0D57030195	BOLT, FLYWHEEL HOUSING 10 x 65	1
03030A	0D57030196	FLYWHEEL ASSEMBLY	1
03034	0D57030197	OIL SLINGER, CRANKSHAFT, RR	1
03057	0D57030198	RING GEAR, FLYWHEEL	1
03080	0D57030199	OIL SEAL, CRANKSHAFT, RR	1
03764A	0D57030200	COUPLING ASSY, FLYWHEEL	1
03794	0D57030201	WASHER, FLYWHEEL	1
03796	0D57030202	PIN, FLYWHEEL	1
03797	0D57030203	BOLT, FLYWHEEL	6
03797B	0D57030204	BOLT, FLYWHEEL	6
81976	0D57030141	PLUG, TACHOMETER DRIVE	1
81984	0D57030174	GASKET, SPEEDOMETER GEAR	1

7.5L DIESEL — PISTON AND CONNECTING ROD

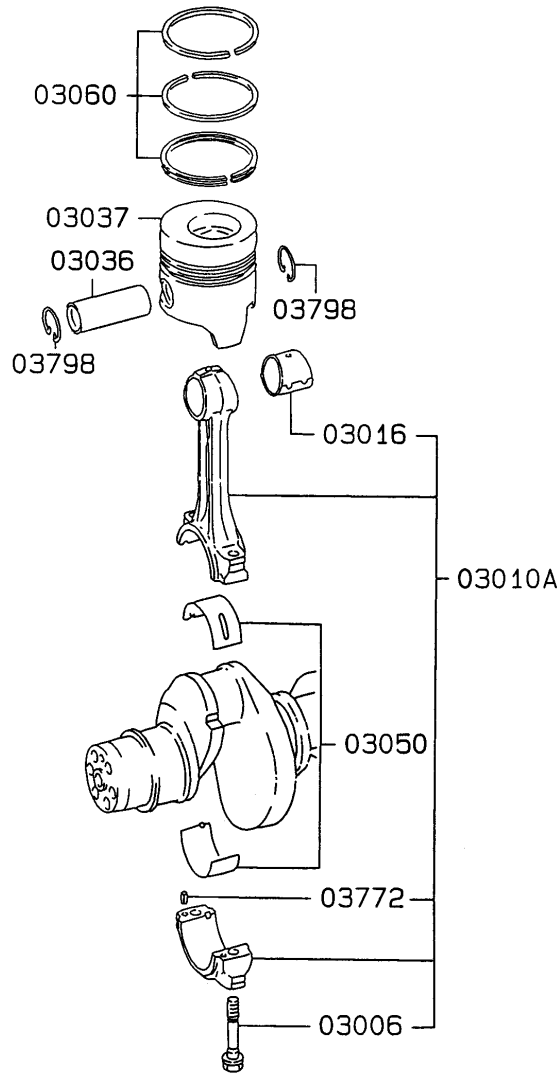

ITEM	PART NUMBER	DESCRIPTION	QTY
03006	0D57030205	BOLT, CONNECTING ROD	12
03010A	0D57030206	CONNECTING ROD ASSY	6
03016	0D57030207	BUSHING, CONNECTING ROD	6
03036	0D57030209	PIN, PISTON	6
03037	0D57030210	PISTON SIZE A	AR
	0D57030211	PISTON SIZE B	AR
03050	0D57030213	BEARING SET, CONN ROD STD	6
	0D57030214	BEARING SET, CONN ROD U/S 0.25	AR
	0D57030215	BEARING SET, CONN ROD U/S 0.50	AR
	0D57030216	BEARING SET, CONN ROD U/S 0.75	AR
	0D57030217	BEARING SET, CONN ROD U/S 1.00	AR
03060	0D57030218	RING SET, PISTON	6
03772	0D57030219	PIN, CONNECTING ROD	12
03798	0D57030223	SNAP RING, PISTON	12

7.5L DIESEL — CRANKSHAFT

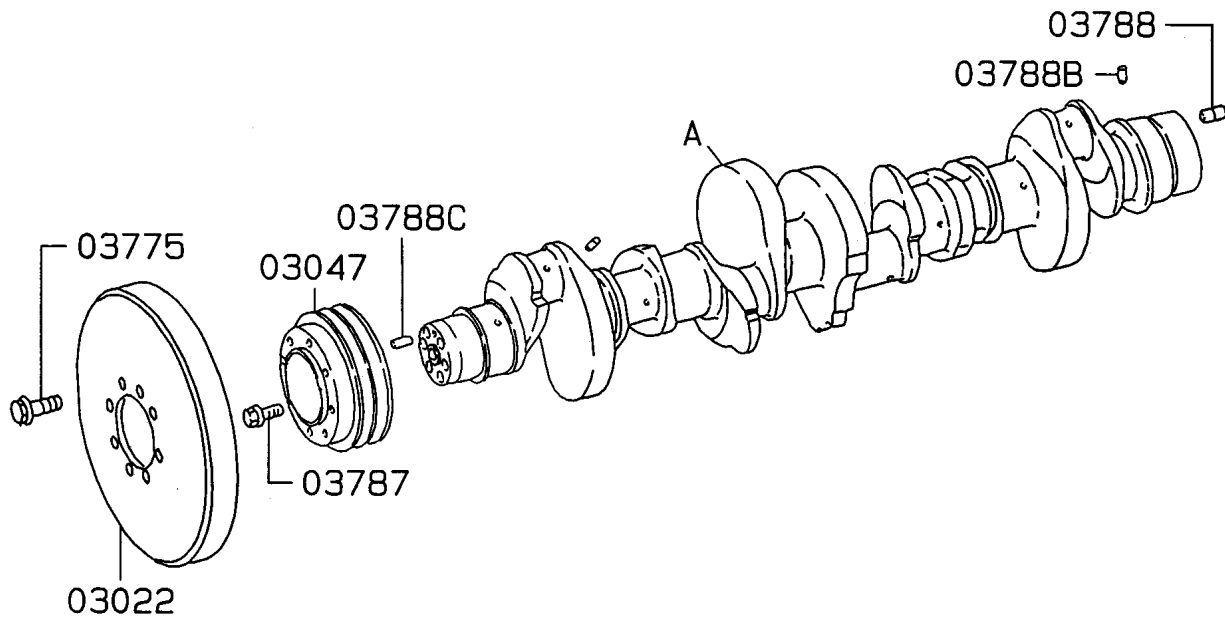

ITEM	PART NUMBER	DESCRIPTION	QTY
03022	0D57030208	DAMPER, CRANKSHAFT TORSIONAL	1
03047	0D57030212	PULLEY, CRANKSHAFT	1
03775	0D57030220	BOLT, TORSIONAL DAMPER	8
03787	0D57030221	BOLT, CRANKSHAFT PULLEY	6
03788	0D57030202	PIN, CRANKSHAFT	1
03788B	0D57030222	PIN, CRANKSHAFT	1
03788C	0D57030147	PIN, CRANKSHAFT	1

7.5L DIESEL — CAMSHAFT AND VALVE

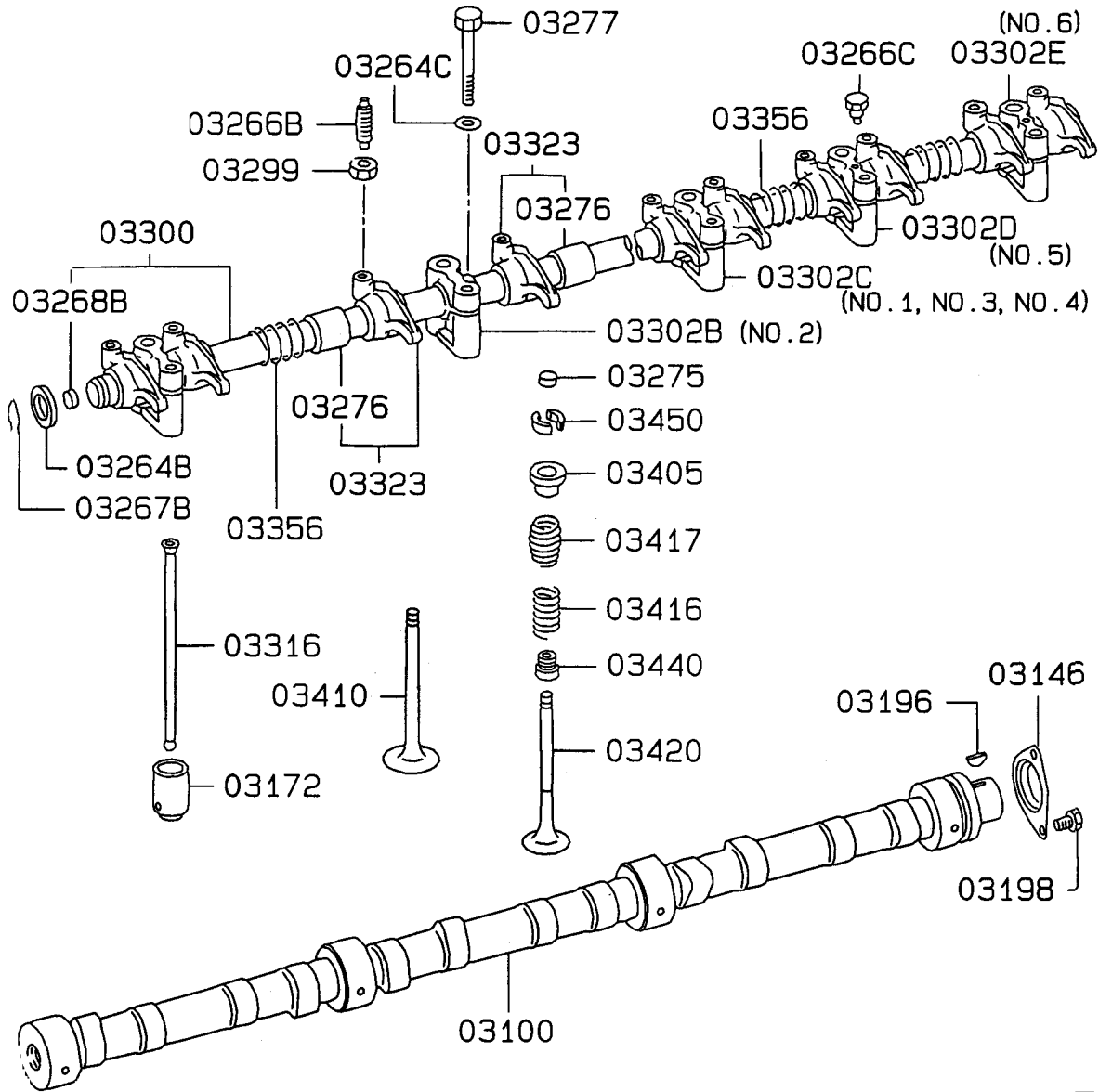

7.5L DIESEL — CAMSHAFT AND VALVE

ITEM	PART NUMBER	DESCRIPTION	QTY
03100	0D57030224	CAMSHAFT	1
03146	0D57030225	PLATE, CAMSHAFT THRUST	1
03172	0D57030226	TAPPET, VALVE	12
03196	0D57030227	KEY, CAMSHAFT	1
03198	0D57030228	BOLT, CAMSHAFT	2
03264B	0D57030229	WASHER, VALVE GEAR TRAIN	2
03264C	0D57030230	WASHER, VALVE GEAR TRAIN	6
03266B	0D57030231	SCREW, VALVE GEAR TRAIN	12
03266C	0D57030232	SCREW, VALVE GEAR TRAIN	1
03267B	0D57030233	SNAP RING, VALVE GEAR TRAIN	2
03268B	0D57030234	PLUG, VALVE GEAR TRAIN	2
03275	0D57030235	CAP, VALVE GEAR TRAIN	12
03276	0D57030236	BUSHING, VALVE GEAR TRAIN	12
03277	0D57030237	BOLT, VALVE GEAR TRAIN	6
03299	0D57030238	NUT, VALVE GEAR TRAIN	12
03300	0D57030239	SHAFT, ROCKER ARM	1
03302B	0D57030240	BRACKET, ROCKER SHAFT	1
03302C	0D57030241	BRACKET, ROCKER SHAFT	3
03302D	0D57030242	BRACKET, ROCKER SHAFT	1
03302E	0D57030243	BRACKET, ROCKER SHAFT	1
03316	0D57030244	PUSH ROD, ROCKER ARM	12
03323	0D57030245	ROCKER ARM, INLET & EXHAUST VALVE	12
03356	0D57030246	SPRING, ROCKER SHAFT	5
03405	0D57030247	RETAINER, VALVE SPRING	12
03410	0D57030248	VALVE, INTAKE	6
03416	0D57030249	SPRING, VALVE, INNER	12
03417	0D57030250	SPRING, VALVE, OUTER	12
03420	0D57030251	VALVE, EXHAUST	6
03440	0D57030252	SEAL, VALVE STEM	12
03450	0D57030253	LOCK, VALVE SPRING RETAINER	24

7.5L DIESEL — TIMING GEAR

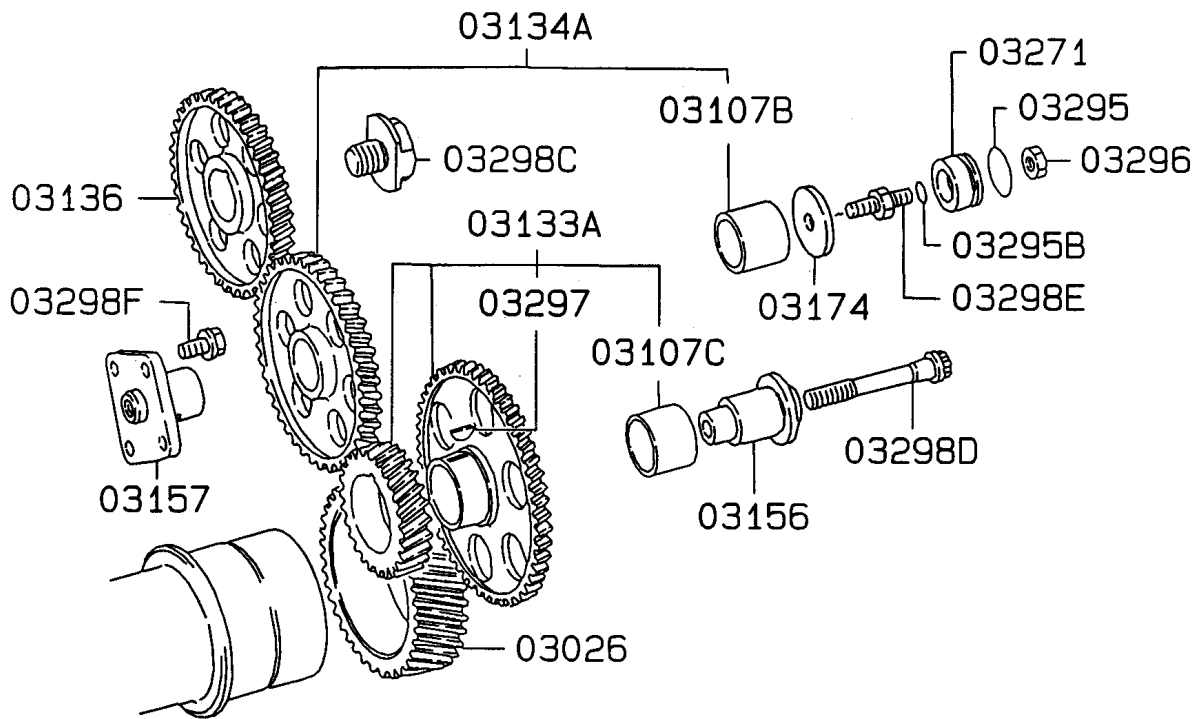

7.5L DIESEL — TIMING GEAR

ITEM	PART NUMBER	DESCRIPTION	QTY
03026	0D57030254	GEAR, CRANKSHAFT	1
03107B	0D57030255	BUSHING, TIMING GEAR TRAIN	1
03107C	0D57030256	BUSHING, TIMING GEAR TRAIN	1
03133A	0D57030257	GEAR ASSY, CAM IDLER 1ST	1
03134A	0D57030258	GEAR ASSY, CAM IDLER 2ND	1
03136	0D57030259	GEAR, CAMSHAFT	1
03156	0D57030260	SHAFT, CAM IDLER 1ST GEAR	1
03157	0D57030261	SHAFT, CAM IDLER 2ND GEAR	1
03174	0D57030262	THRUST WASHER, TIMING GEAR TRAIN	1
03271	0D57030263	COLLAR, TIMING GEAR TRAIN	1
03295	0D57030264	O-RING, TIMING GEAR TRAIN	1
03295B	0D57030265	O-RING, TIMING GEAR TRAIN	1
03296	0D57030266	NUT, TIMING GEAR TRAIN	1
03297	0D57030227	KEY, TIMING GEAR TRAIN	1
03298C	0D57030267	BOLT, TIMING GEAR TRAIN	1
03298D	0D57030268	BOLT, TIMING GEAR TRAIN	1
03298E	0D57030269	BOLT, TIMING GEAR TRAIN	1
03298F	0D57030270	BOLT, TIMING GEAR TRAIN	4

7.5L DIESEL — ATTACHING PARTS

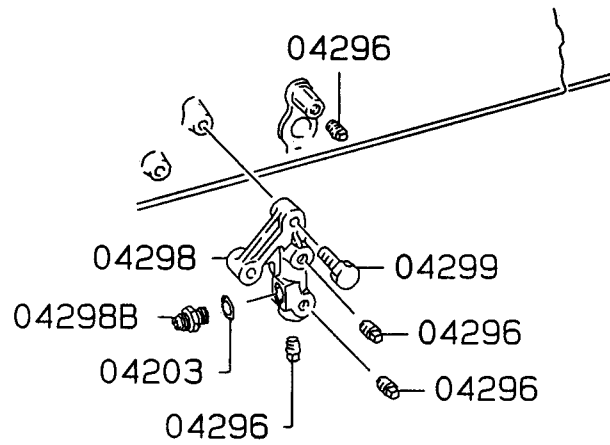
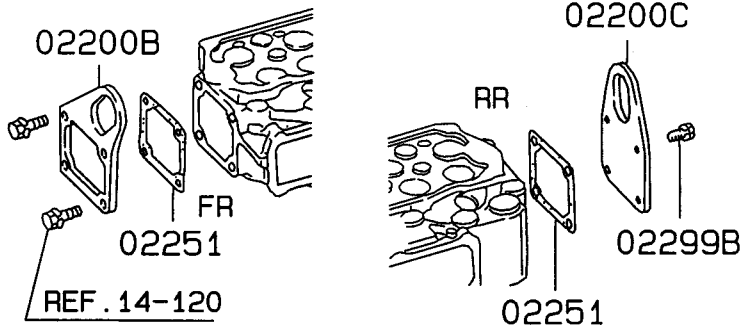
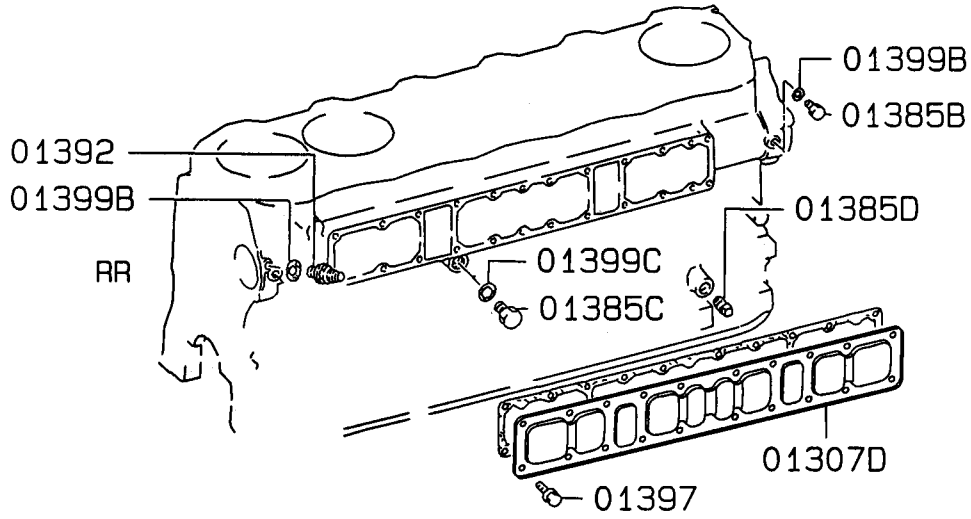

7.5L DIESEL — ATTACHING PARTS

ITEM	PART NUMBER	DESCRIPTION	QTY
01307D	0D57030271	COVER, CYLINDER BLOCK	1
01385B	0D57030272	PLUG, CYLINDER BLOCK	1
01385C	0D57030273	PLUG, CYLINDER BLOCK	1
01385D	0D57030274	PLUG, CYLINDER BLOCK	1
01392	0D57030275	JOINT, CYLINDER BLOCK	1
01397	0D57030276	BOLT, CYLINDER BLOCK	20
01399B	0D57030277	GASKET, CYLINDER BLOCK	2
01399C	0D57030162	GASKET, CYLINDER BLOCK	1
02200B	0D57030278	ENGINE HANGER	1
02200C	0D57030279	ENGINE HANGER	1
02251	0D57030280	GASKET, ENGINE HANGER	2
02299B	0D57030281	BOLT, ENGINE HANGER	4
04203	0D57030277	GASKET, ENGINE OIL PRESSURE GAUGE	1
04296	0D57030282	PLUG, ENGINE OIL PRESSURE GAUGE	4
04298	0D57030283	JOINT, ENGINE OIL PRESSURE GAUGE	1
04298B	0D57030284	JOINT, ENGINE OIL PRESSURE GAUGE	1
04299	0D57030285	BOLT, ENGINE OIL PRESSURE GAUGE	2

7.5L DIESEL — OIL PUMP AND STRAINER

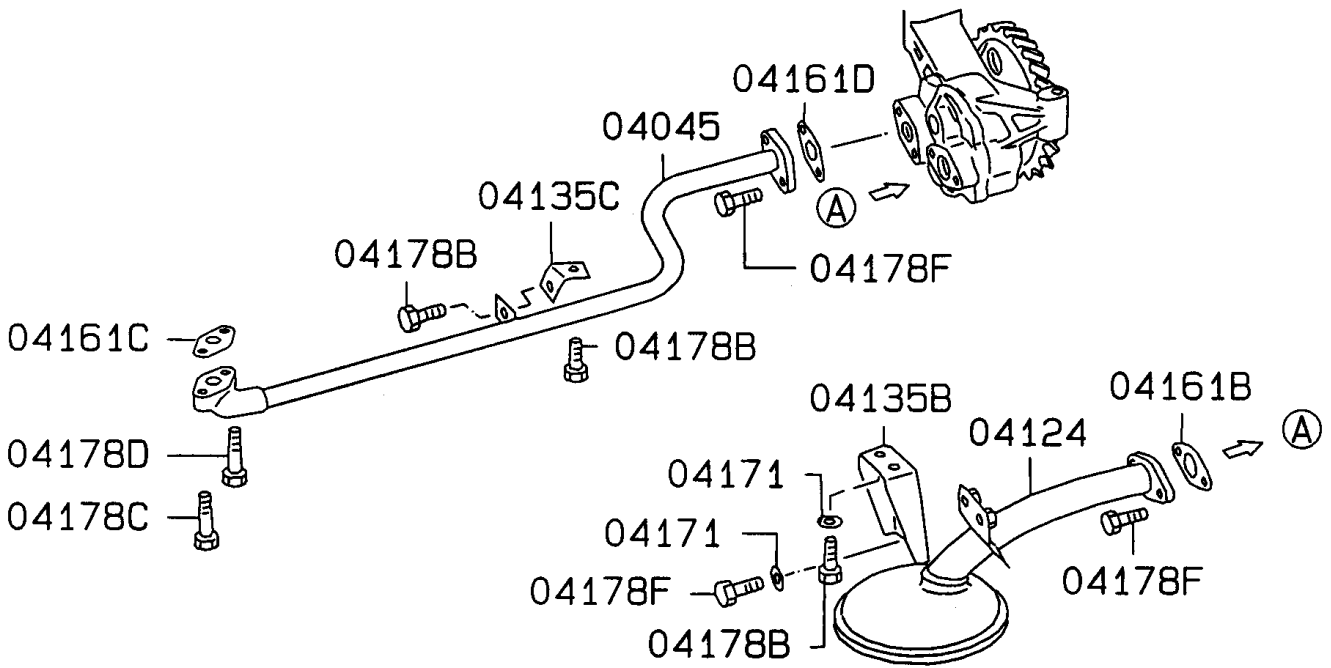
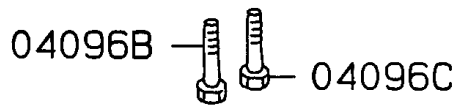
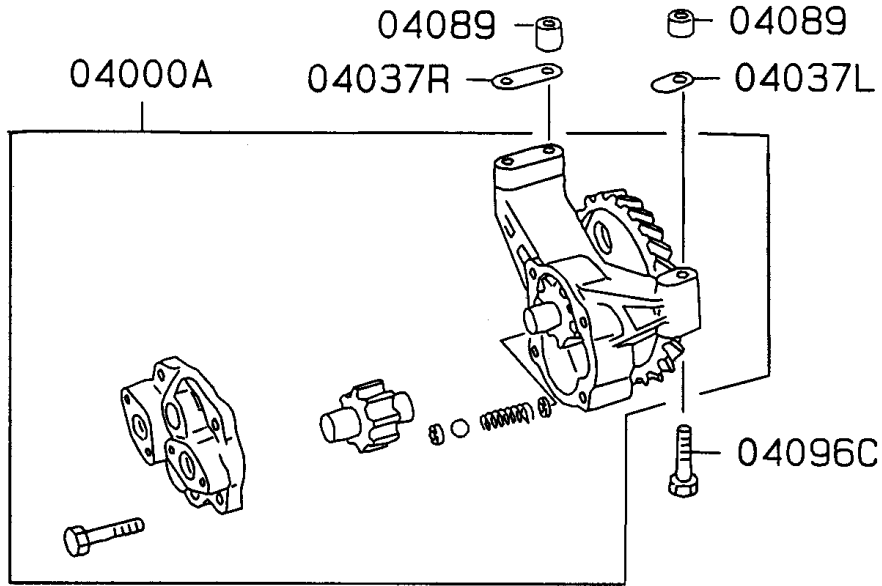

7.5L DIESEL — OIL PUMP AND STRAINER

ITEM	PART NUMBER	DESCRIPTION	QTY
04000A	0D57030288	OIL PUMP ASSEMBLY	1
04037L	0D57030289	SHIM, ENGINE OIL PUMP CASE, LH, T=0.1	AR
	0D57030290	SHIM, ENGINE OIL PUMP CASE, LH, T=0.2	AR
04037R	0D57030291	SHIM, ENGINE OIL PUMP CASE, RH, T=0.1	AR
	0D57030292	SHIM, ENGINE OIL PUMP CASE, RH, T=0.2	AR
04045	0D57030293	TUBE, ENGINE OIL PUMP OUTLET	1
04089	0D57030294	PIN, ENGINE OIL PUMP	2
04096B	0D57030193	BOLT, ENGINE OIL PUMP	1
04096C	0D57030195	BOLT, ENGINE OIL PUMP	2
04124	0D57030295	STRAINER, ENGINE OIL PAN	1
04135B	0D57030296	STAY, OIL STRAINER	1
04135C	0D57030297	STAY, OIL STRAINER	1
04161B	0D57030298	GASKET, OIL STRAINER	1
04161C	0D57030299	GASKET, OIL STRAINER	1
04161D	0D57030300	GASKET, OIL STRAINER	1
04171	0D57030301	WASHER, OIL STRAINER	4
04178B	0D57030228	BOLT, OIL STRAINER	4
04178C	0D57030302	BOLT, OIL STRAINER	1
04178D	0D57030303	BOLT, OIL STRAINER	1
04178F	0D57030304	BOLT, OIL STRAINER	6

7.5L DIESEL — OIL FILTER

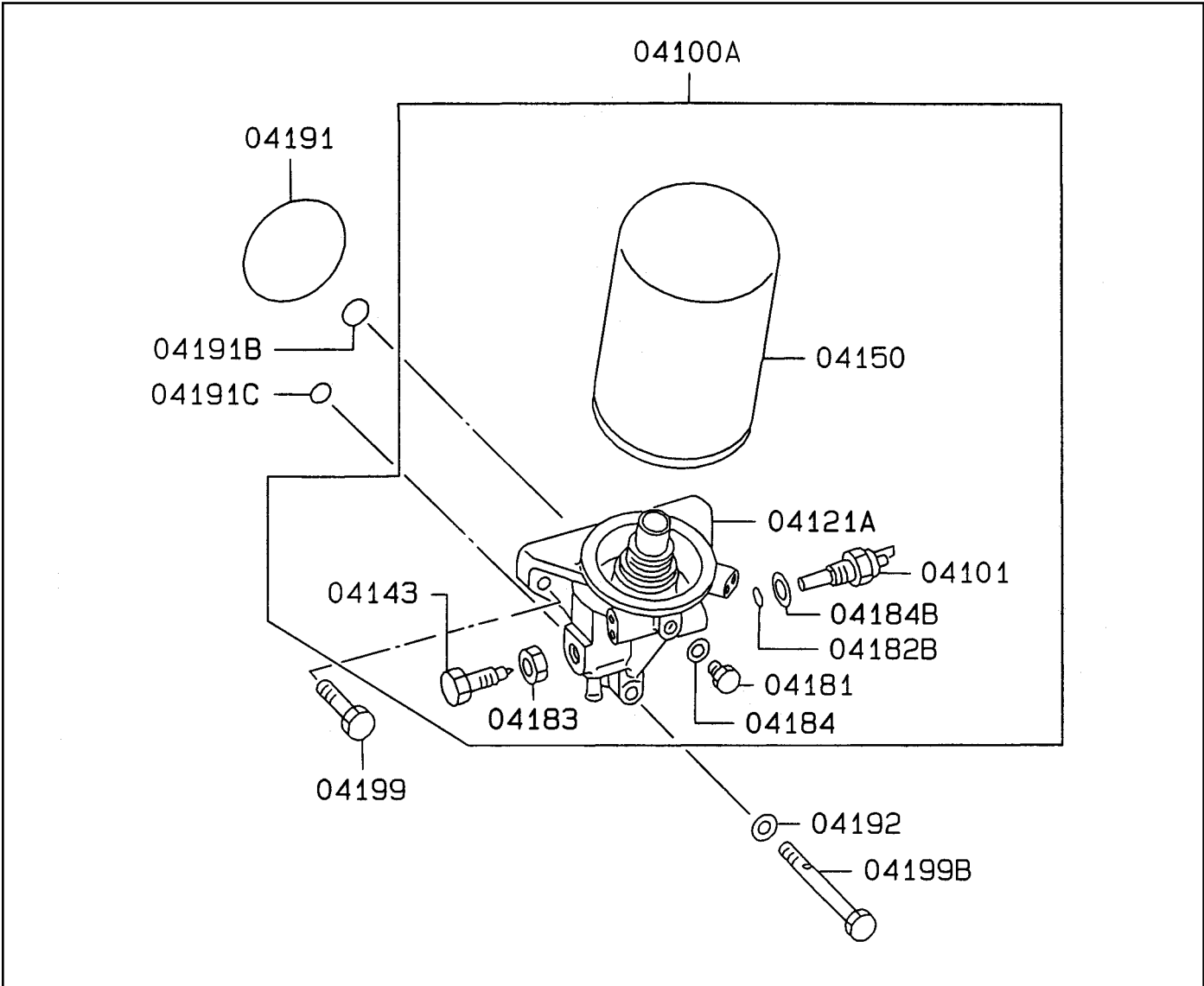

ITEM	PART NUMBER	DESCRIPTION	QTY
04100A	0D57030305	OIL FILTER AND HEAD ASSY	1
04101	0D57030306	SWITCH, OIL FILTER BY-PASS	1
04121A	0D57030307	HEAD ASSEMBLY, OIL FILTER	1
04143	0D57030308	VALVE, OIL FILTER DRAIN	1
04150	0D57030309	OIL FILTER	1
04181	0D57030310	PLUG, OIL FILTER INNER	1
04182B	0D57030311	O-RING, OIL FILTER INNER	1
04183	0D57030312	NUT, OIL FILTER INNER	1
04184	0D57030313	GASKET, OIL FILTER INNER	1
04184B	0D57030174	GASKET, OIL FILTER INNER	1
04191	0D57030314	O-RING, OIL FILTER	1
04191B	0D57030315	O-RING, OIL FILTER	1
04191C	0D57030316	O-RING, OIL FILTER	1
04192	0D57030277	GASKET, OIL FILTER	1
04199	0D57030285	BOLT, OIL FILTER	2
04199B	0D57030317	BOLT, OIL FILTER	1

7.5L DIESEL — OIL COOLER

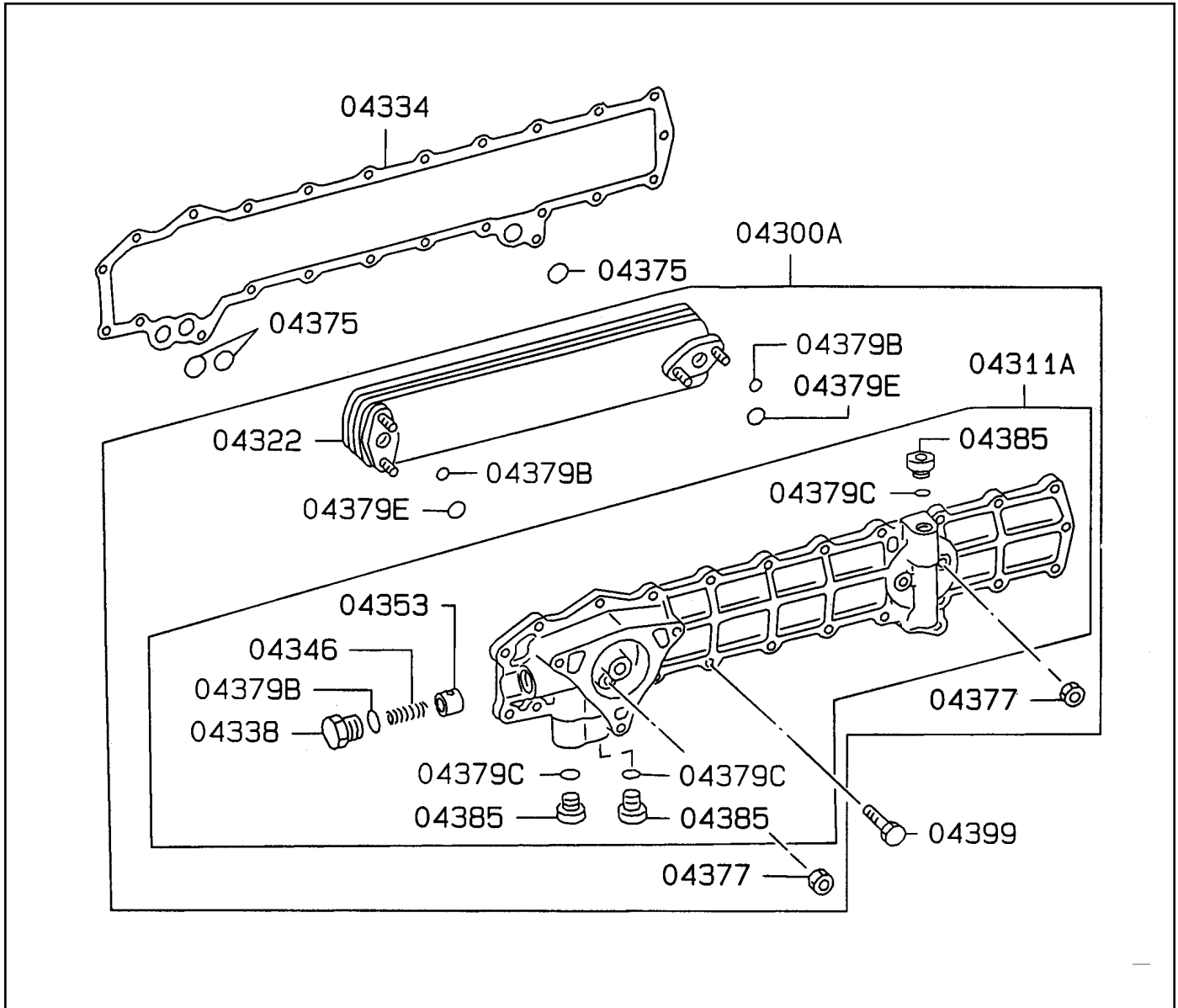

ITEM	PART NUMBER	DESCRIPTION	QTY
04300A	0D57030318	OIL COOLER ASSEMBLY	1
04311A	0D57030319	COVER ASSEMBLY, OIL COOLER	1
04322	0D57030320	ELEMENT, ENGINE OIL COOLER	1
04334	0D57030321	GASKET, ENGINE OIL COOLER COVER	1
04338	0D57030322	PLUG, ENGINE OIL COOLER	1
04346	0D57030323	SPRING, ENGINE OIL COOLER BY-PASS VALVE	1
04353	0D57030324	VALVE, ENGINE OIL COOLER BY-PASS	1
04375	0D57030325	O-RING, ENGINE OIL COOLER	3
04377	0D57030326	NUT, ENGINE OIL COOLER INNER	4
04379B	0D57030327	O-RING, ENGINE OIL COOLER INNER	5
04379C	0D57030328	O-RING, ENGINE OIL COOLER INNER	3
04379E	0D57030329	O-RING, ENGINE OIL COOLER INNER	2
04385	0D57030330	PLUG, ENGINE OIL COOLER INNER	3
04399	0D57030331	BOLT, ENGINE OIL COOLER	23

7.5L DIESEL — OIL LINE

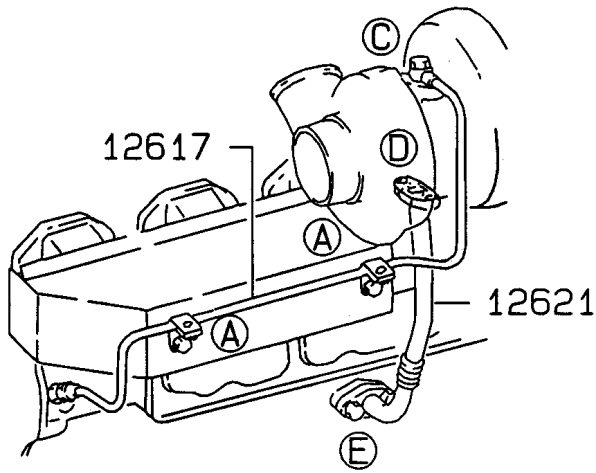
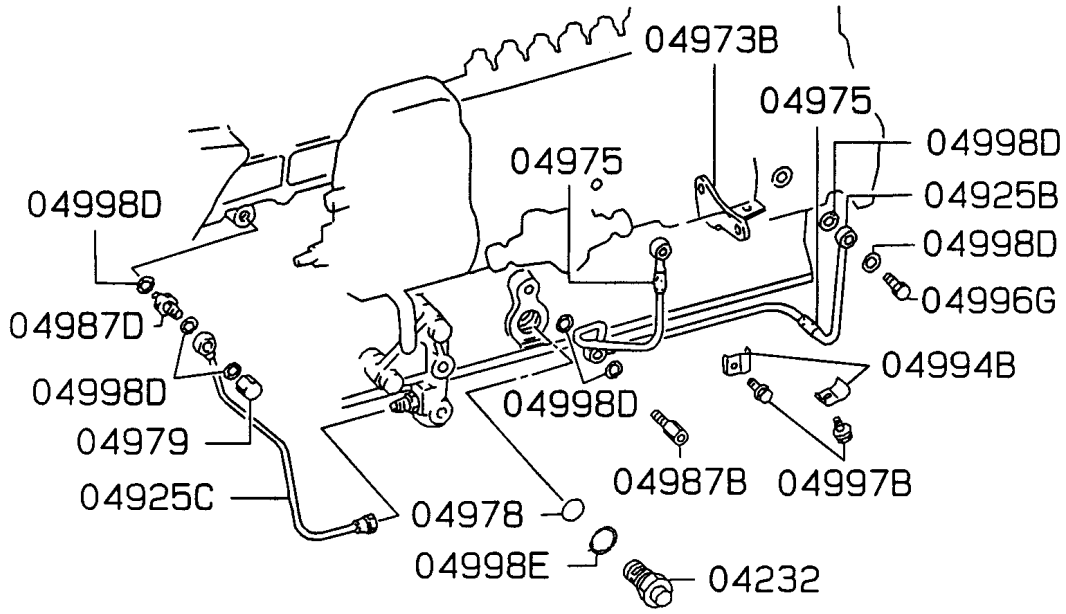

- (A) 04973C
04997C
- 04997B
- (C) 04996D
04998D
- (D) 12537
04997D
- (E) 12548
04997E

7.5L DIESEL — OIL LINE

ITEM	PART NUMBER	DESCRIPTION	QTY
04232	0D57030332	VALVE, ENGINE OIL PRESSURE REGULATING	1
04925B	0D57030333	TUBE, ENGINE OIL LINE	1
04925C	0D57030334	TUBE, ENGINE OIL LINE	1
04973B	0D57030335	STAY, ENGINE OIL LINE	1
04973C	0D57030336	STAY, ENGINE OIL LINE	2
04975	0D57030337	PROTECTOR, ENGINE OIL LINE	2
04978	0D57030338	O-RING, ENGINE OIL LINE	1
04979	0D57030339	NUT, ENGINE OIL LINE	1
04987B	0D57030340	JOINT, ENGINE OIL LINE	1
04987D	0D57030341	JOINT, ENGINE OIL LINE	1
04994B	0D57030342	CLAMP, ENGINE OIL LINE	2
04996D	0D57030344	EYEBOLT, ENGINE OIL LINE	1
04996G	0D57030345	EYEBOLT, ENGINE OIL LINE	1
04997B	0D57030346	BOLT, ENGINE OIL LINE	4
04997C	0D57030347	BOLT, ENGINE OIL LINE	2
04997D	0D57030160	BOLT, ENGINE OIL LINE	2
04997E	0D57030228	BOLT, ENGINE OIL LINE	2
04998D	0D57030277	GASKET, ENGINE OIL LINE	9
04998E	0D57030348	GASKET, ENGINE OIL LINE	1
12537	0D57030349	GASKET, T/C OIL RETURN TUBE	1
12548	0D57030350	GASKET, T/C OIL RETURN PIPE TO CYL BLOCK	1
12617	0D57030351	TUBE, T/C OIL FEED	1
12621	0D57030352	TUBE, T/C OIL RETURN	1

7.5L DIESEL — FUEL FILTER AND HOSE

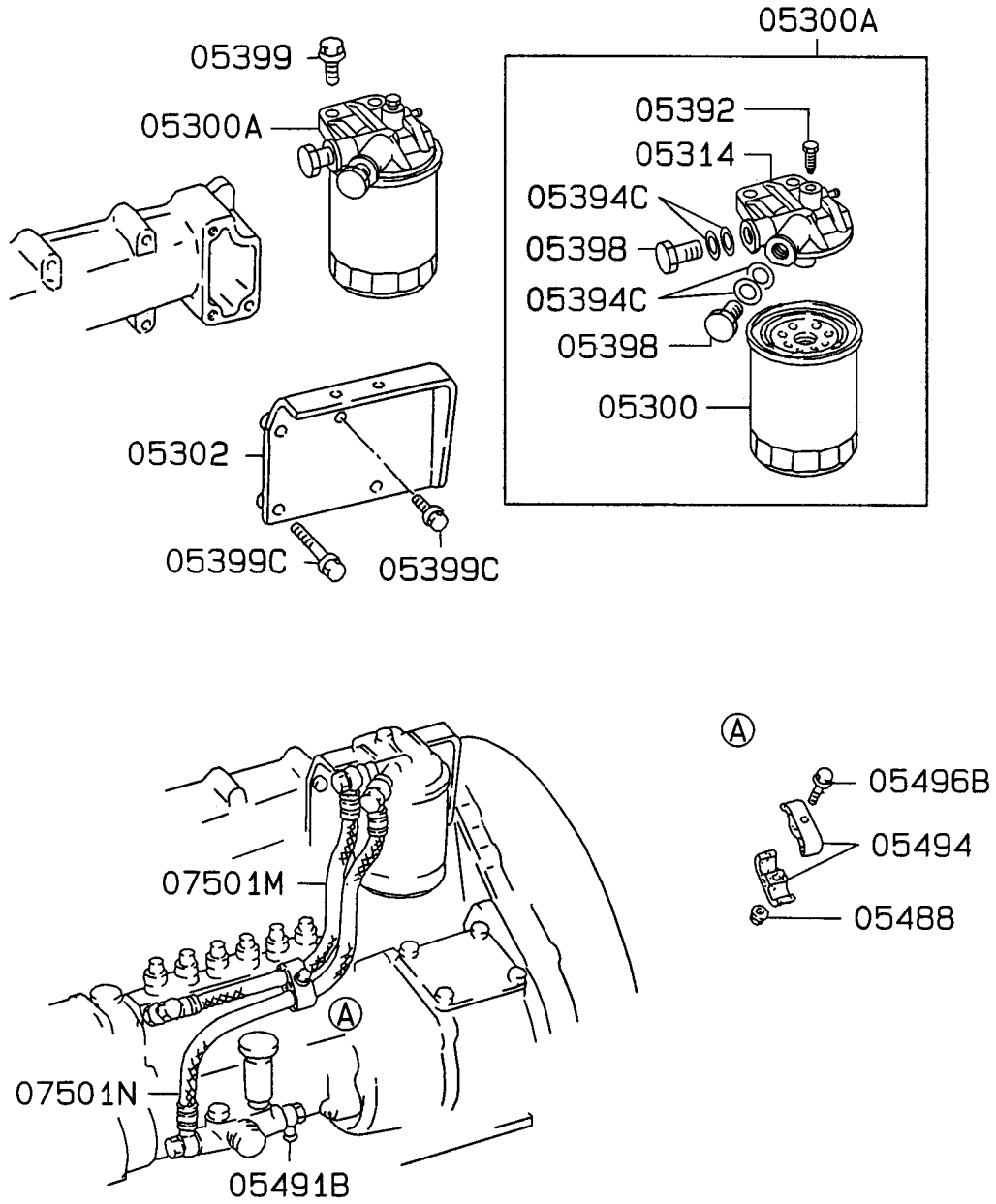

7.5L DIESEL — FUEL FILTER AND HOSE

ITEM	PART NUMBER	DESCRIPTION	QTY
05300	0D57030353	FUEL FILTER	1
05300A	0D57030354	FUEL FILTER ASSEMBLY	1
05302	0D57030355	BRACKET, FUEL FILTER	1
05314	0D57030356	HEAD, FUEL FILTER	1
05392	0D57030357	PLUG, FUEL FILTER	1
05394C	0D57030358	GASKET, FUEL FILTER	4
05398	0D57030359	EYEBOLT, FUEL FILTER	2
05399	0D57030360	BOLT, FUEL FILTER	2
05399C	0D57030361	BOLT, FUEL FILTER 8 x 20	1
	0D57030362	BOLT, FUEL FILTER 8 x 75	3
05488	0D57030363	NUT, FUEL LINE	1
05491B	0D57030364	JOINT, FUEL LINE	1
05494	0D57030365	CLAMP, FUEL LINE	2
05496B	0D57030366	BOLT, FUEL LINE	1
07501M	0D57030367	HOSE, INJECTION PUMP FUEL FEED	1
07501N	0D57030368	HOSE, INJECTION PUMP FUEL FEED	1

7.5L DIESEL — FUEL INJECTION PUMP

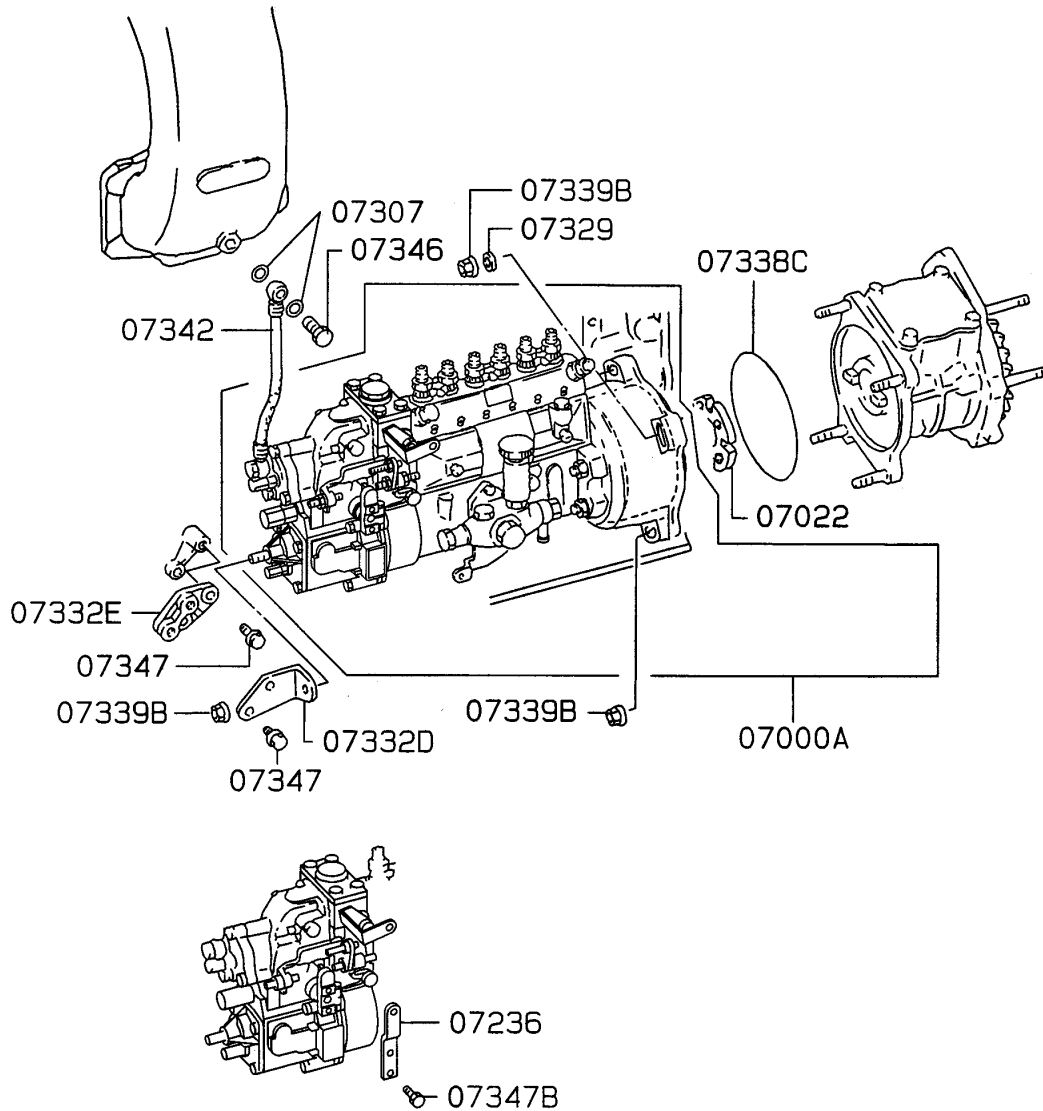

ITEM	PART NUMBER	DESCRIPTION	QTY
07000A	0D57030369	PUMP ASSY, FUEL INJECTION	1
07022	0D57030371	DISC, INJECTION PUMP DRIVING	1
07236	0D57030372	LEVER, INJECTION PUMP GOVERNOR	1
07307	0D57030277	GASKET, INJECTION PUMP FUEL FEED PUMP	2
07329	0D57030373	WASHER, INJECTION PUMP	2
07332D	0D57030376	STAY, INJECTION PUMP BODY	1
07332E	0D57030377	STAY, INJECTION PUMP BODY	1
07338C	0D57030379	O-RING, INJECTION PUMP	1
07339B	0D57030326	NUT, INJECTION PUMP	5
07342	0D57030380	HOSE, INJECTION PUMP	1
07346	0D57030381	EYEBOLT, INJECTION PUMP	1
07347	0D57030160	BOLT, INJECTION PUMP	4
07347B	0D57030382	BOLT, INJECTION PUMP	2

7.5L DIESEL — FUEL INJECTION PUMP

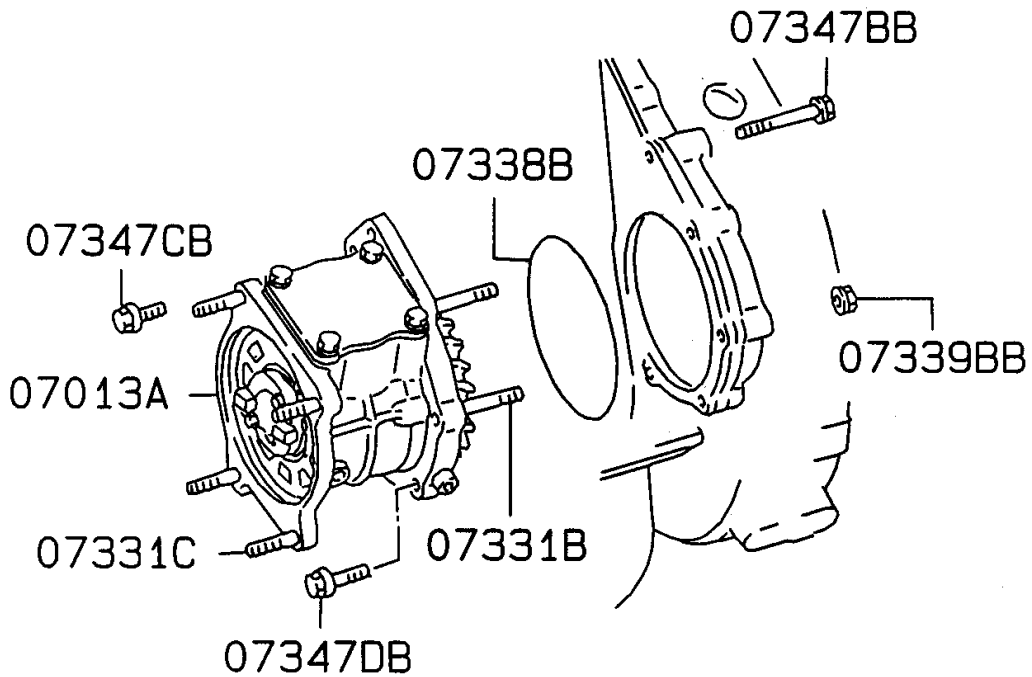

ITEM	PART NUMBER	DESCRIPTION	QTY
07013A	0D57030370	CASE ASSY, INJECTION PUMP DRIVE	1
07331B	0D57030374	STUD, INJECTION PUMP	2
07331C	0D57030375	STUD, INJECTION PUMP	4
07338B	0D57030378	O-RING, INJECTION PUMP	1
07339BB	0D57030326	NUT, INJECTION PUMP	2
07347BB	0D57030191	BOLT, INJECTION PUMP	1
07347CB	0D57030383	BOLT, INJECTION PUMP	1
07347DB	0D57030285	BOLT, INJECTION PUMP	2

7.5L DIESEL — INJECTION PIPE

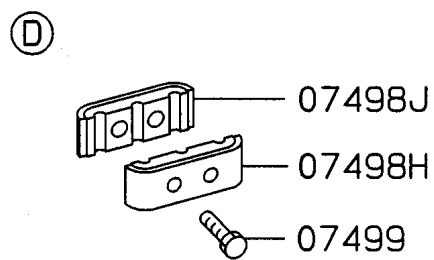
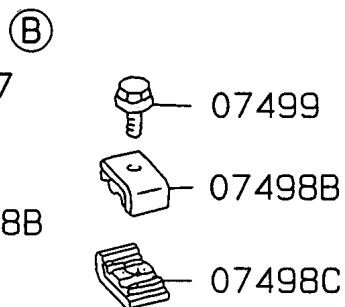
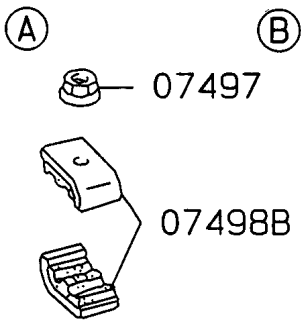
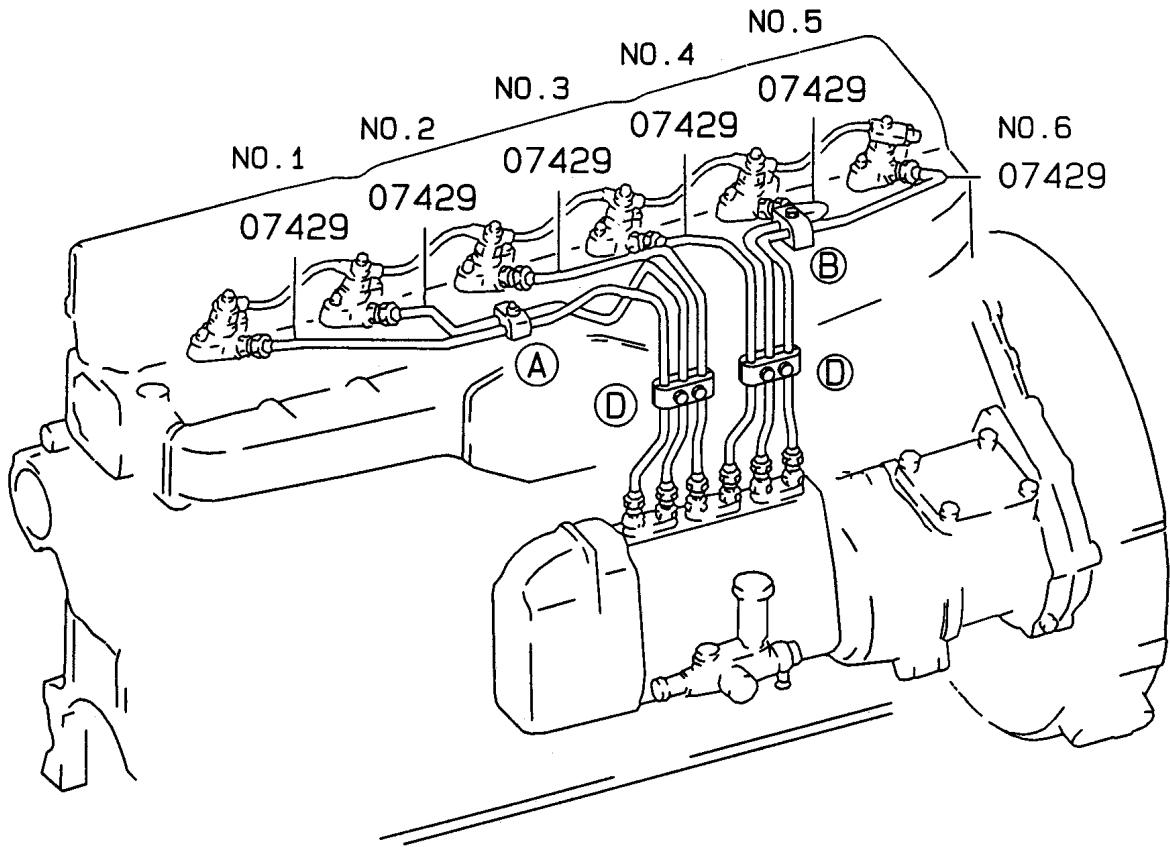

7.5L DIESEL — INJECTION PIPE

ITEM	PART NUMBER	DESCRIPTION	QTY
07429	0D57030394	TUBE, FUEL INJECTION NO. 4	1
	0D57030395	TUBE, FUEL INJECTION NO. 5	1
	0D57030396	TUBE, FUEL INJECTION NO. 3	1
	0D57030397	TUBE, FUEL INJECTION NO. 6	1
	0D57030398	TUBE, FUEL INJECTION NO. 2	1
	0D57030399	TUBE, FUEL INJECTION NO. 1	1
07497	0D57030363	NUT, FUEL INJECTION TUBE	1
07498B	0D57030407	CLAMP, FUEL INJECTION TUBE	3
07498C	0D57030408	CLAMP, FUEL INJECTION TUBE	1
07498H	0D57030409	CLAMP, FUEL INJECTION TUBE	2
07498J	0D57030410	CLAMP, FUEL INJECTION TUBE	2
07499	0D57030411	BOLT, FUEL INJECTION TUBE	5

7.5L DIESEL — INJECTION NOZZLE

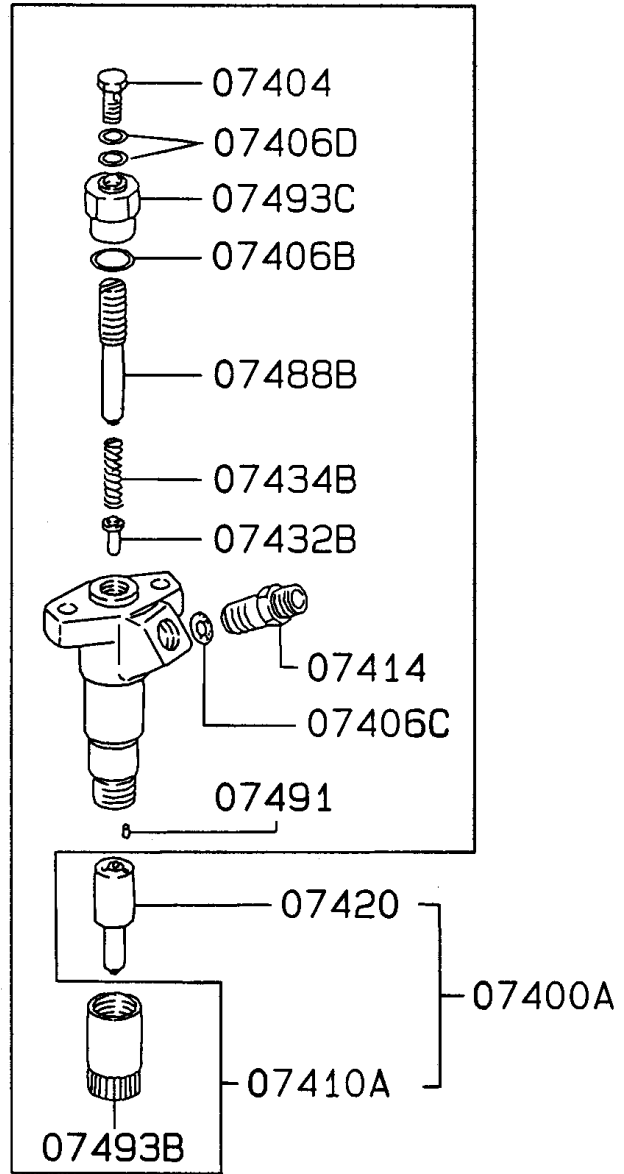
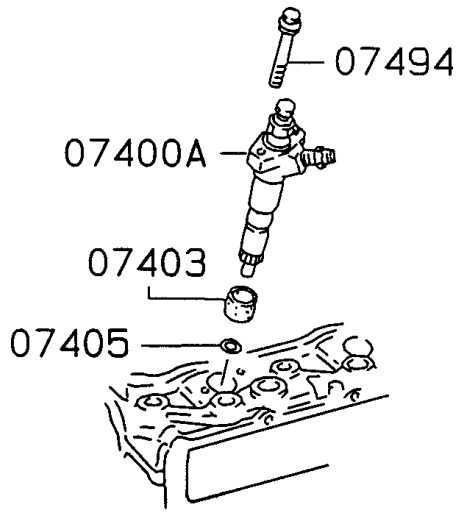

7.5L DIESEL — INJECTION NOZZLE

ITEM	PART NUMBER	DESCRIPTION	QTY
07400A	0D57030384	NOZZLE AND HOLDER ASSY	6
07403	0D57030385	DUST SEAL, NOZZLE HOLDER	6
07404	0D57030386	EYEBOLT, FUEL INJECTION NOZZLE	6
07405	0D57030387	GASKET, FUEL INJECTION NOZZLE	6
07406B	0D57030388	GASKET, FUEL INJECTION NOZZLE INNER	6
07406C	0D57030389	GASKET, FUEL INJECTION NOZZLE INNER	6
07406D	0D57030390	GASKET, FUEL INJECTION NOZZLE INNER	12
07410A	0D57030391	HOLDER ASSY, FUEL INJECTION NOZZLE	6
07414	0D57030392	JOINT, FUEL INJECTION NOZZLE HOLDER	6
07420	0D57030393	NOZZLE, FUEL INJECTION	6
07432B	0D57030400	PUSH ROD, NOZZLE HOLDER	6
07434B	0D57030401	SPRING, NOZZLE HOLDER	6
07488B	0D57030402	SCREW, FUEL INJECTION NOZZLE	6
07491	0D57030403	PIN, FUEL INJECTION NOZZLE	12
07493B	0D57030404	NUT, FUEL INJECTION NOZZLE	6
07493C	0D57030405	NUT, FUEL INJECTION NOZZLE	6
07494	0D57030406	BOLT, FUEL INJECTION NOZZLE	12

7.5L DIESEL — FUEL RETURN HOSE

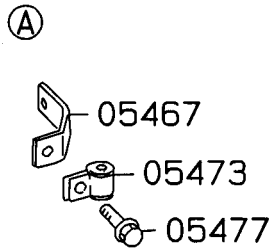
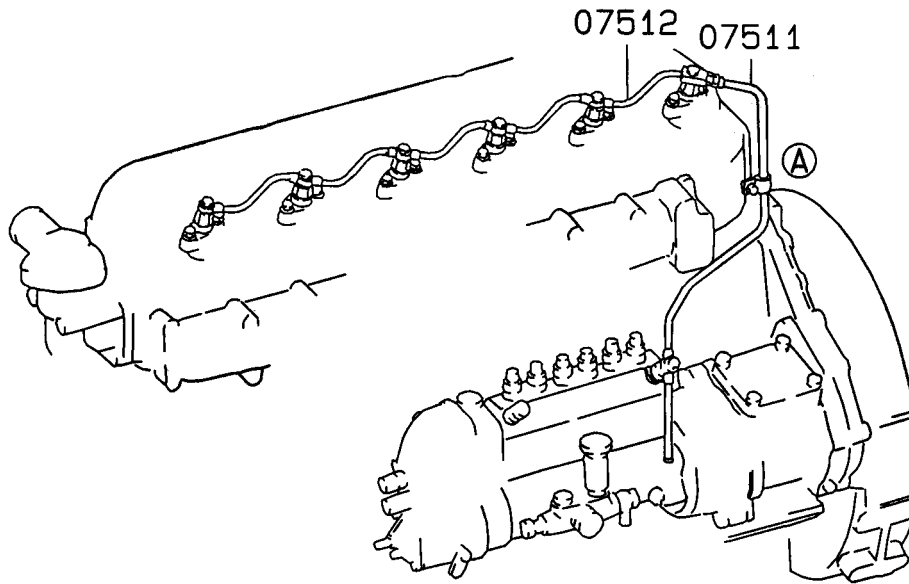

ITEM	PART NUMBER	DESCRIPTION	QTY
05467	0D57030412	STAY, FUEL RETURN LINE	1
05473	0D57030413	CLIP, FUEL RETURN LINE	1
05477	0D57030114	BOLT, FUEL RETURN LINE	1
07511	0D57030414	TUBE, INJECTION PUMP FUEL RETURN	1
07512	0D57030415	TUBE, FUEL INJECTION NOZZLE FUEL RETURN	1

7.5L DIESEL — ENGINE MOUNTING AND SUPPORT

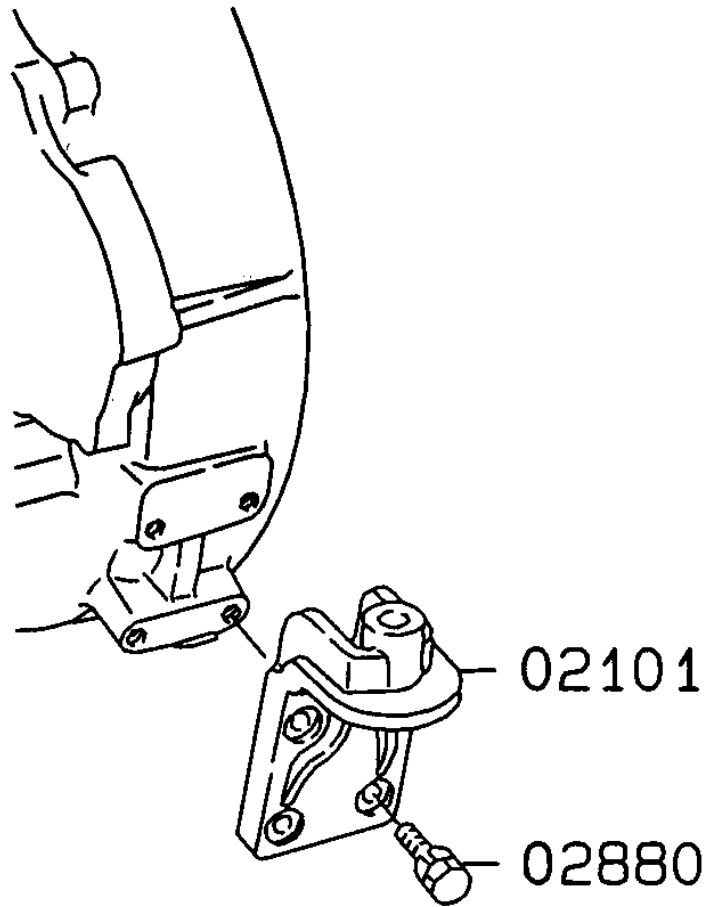

ITEM	PART NUMBER	DESCRIPTION	QTY
02101	0D57030286	BRACKET, FLYWHEEL HOUSING ENG MOUNTING	2
02880	0D57030287	BOLT, ENGINE RR MOUNTING	8

7.5L DIESEL — WATER PUMP AND FAN

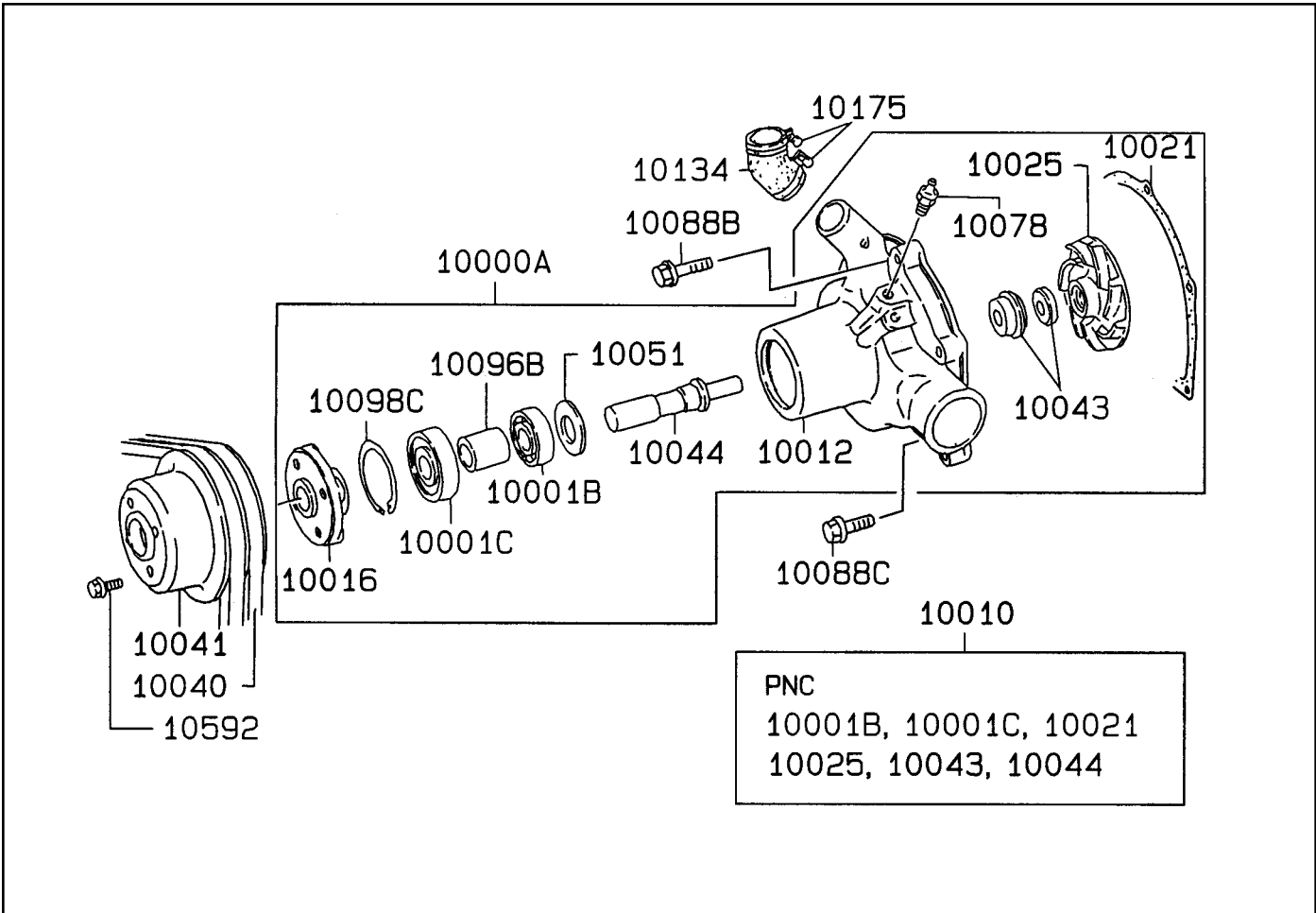

ITEM	PART NUMBER	DESCRIPTION	QTY
10000A	0D57030416	WATER PUMP ASSEMBLY	1
10001B	0D57030417	BEARING, WATER PUMP	1
10001C	0D57030418	BEARING, WATER PUMP	1
10010	0D57030419	WATER PUMP KIT	1
10012	0D57030420	CASE, WATER PUMP	1
10016	0D57030421	FLANGE, WATER PUMP PULLEY DRIVE	1
10021	0D57030422	GASKET, WATER PUMP	1
10025	0D57030423	IMPELLER, WATER PUMP	1
10040	0D57030424	BELT, ALTERNATOR	1
10041	0D57030425	PULLEY, WATER PUMP	1
10043	0D57030426	SEAL UNIT, WATER PUMP SHAFT	1
10044	0D57030427	SHAFT, WATER PUMP	1
10051	0D57030428	THRUST WASHER, WATER PUMP INNER	1
10078	0D57030429	NIPPLE, WATER PUMP INNER	1
10088B	0D57030302	BOLT, WATER PUMP	5
10088C	0D57030331	BOLT, WATER PUMP	2
10096B	0D57030430	SPACER, WATER PUMP INNER	1
10098C	0D57030431	SNAP RING, WATER PUMP INNER	1
10134	0D57030432	HOSE, THERMOSTAT WATER BY-PASS	1
10175	0D57030433	CLAMP, THERMOSTAT	2
10592	0D57030160	BOLT, COOLING FAN	4

7.5L DIESEL — WATER PIPE AND THERMOSTAT

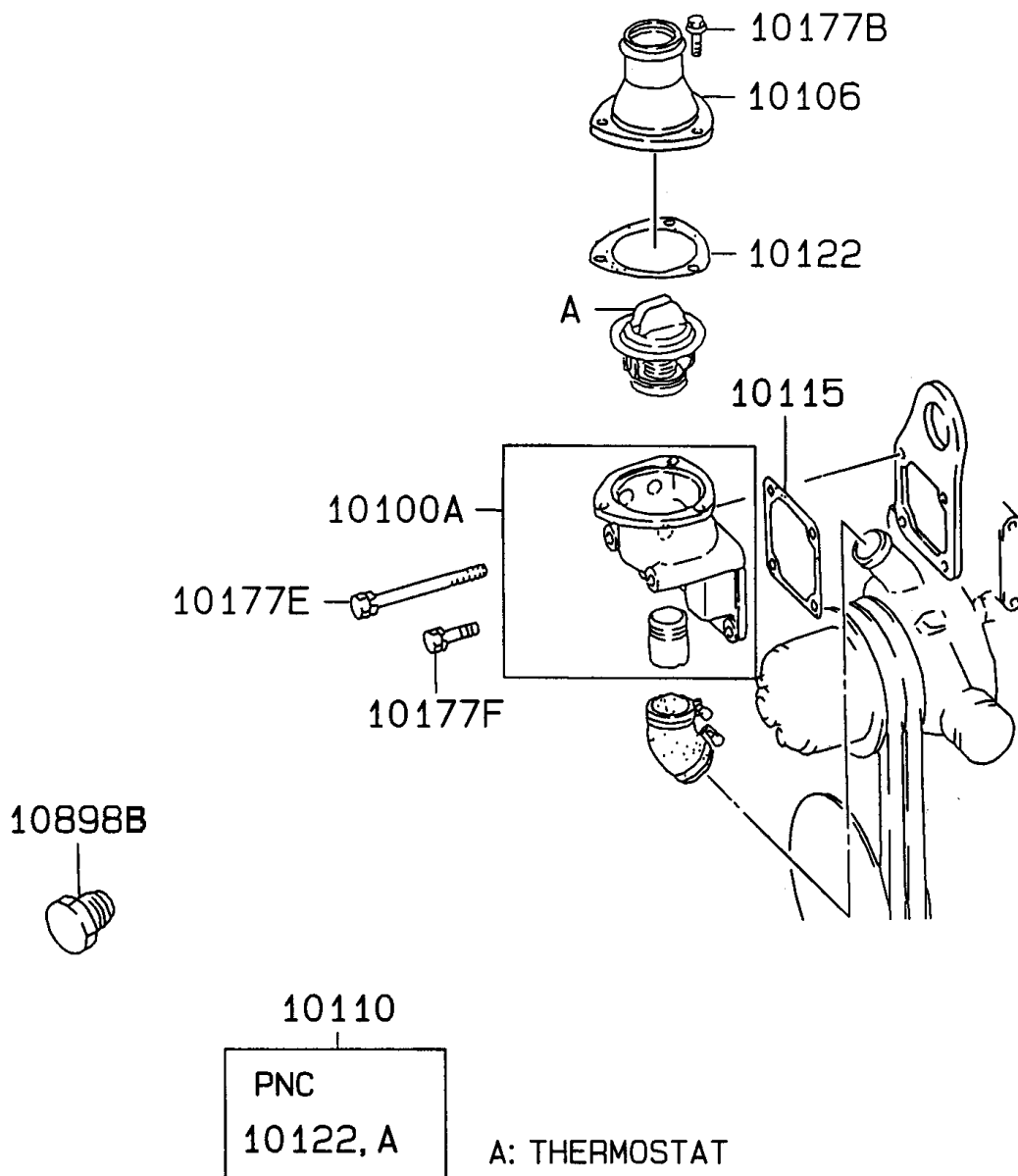

ITEM	PART NUMBER	DESCRIPTION	QTY
10100A	0D57030434	CASE ASSY, THERMOSTAT	1
10106	0D57030435	COVER, THERMOSTAT CASE	1
10110	0D57030436	THERMOSTAT KIT	1
10115	0D57030280	GASKET, THERMOSTAT CASE TO CYL HEAD	1
10122	0D57030437	GASKET, THERMOSTAT COVER	1
10177B	0D57030438	BOLT, THERMOSTAT	3
10177E	0D57030439	BOLT, THERMOSTAT	2
10177F	0D57030440	BOLT, THERMOSTAT	2
10898B	0D57030441	PLUG, WATER TEMPERATURE GAUGE	2

7.5L DIESEL — INTAKE MANIFOLD

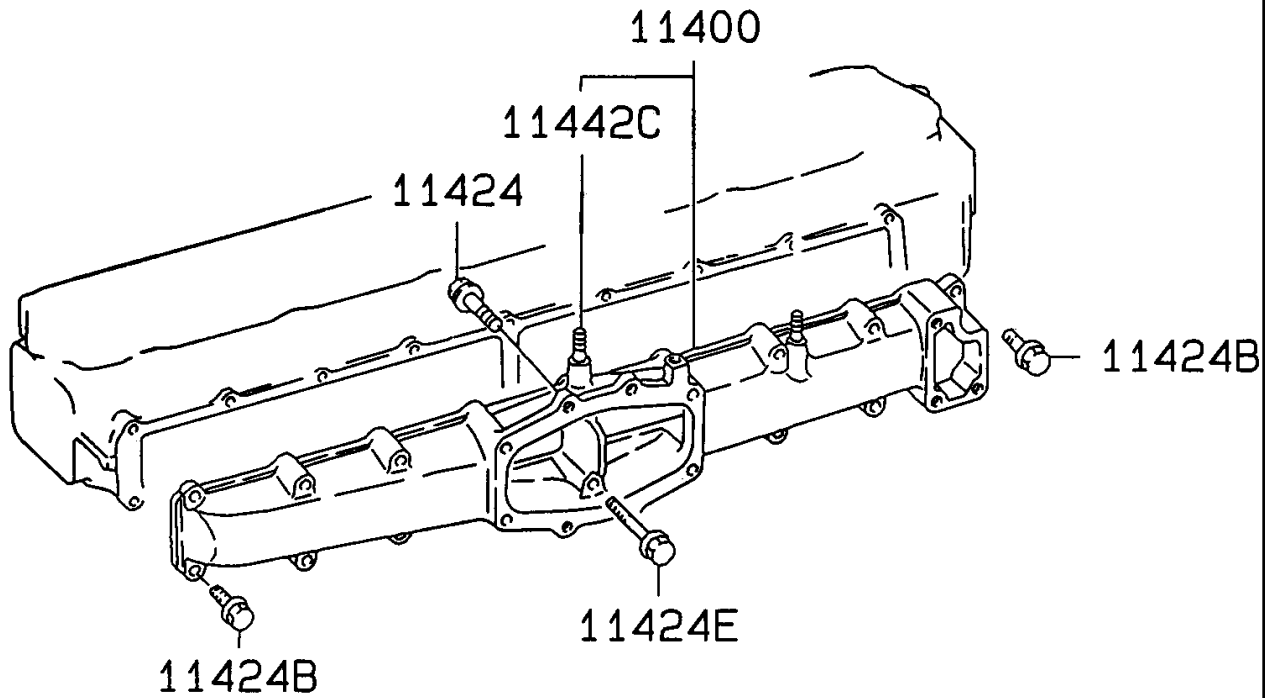

ITEM	PART NUMBER	DESCRIPTION	QTY
11400	0D57030442	MANIFOLD, INTAKE	1
11424	0D57030443	BOLT, INTAKE MANIFOLD	12
11424B	0D57030304	BOLT, INTAKE MANIFOLD	3
11424E	0D57030444	BOLT, INTAKE MANIFOLD	2
11442C	0D57030445	STUD, INTAKE MANIFOLD	1

7.5L DIESEL — EXHAUST MANIFOLD

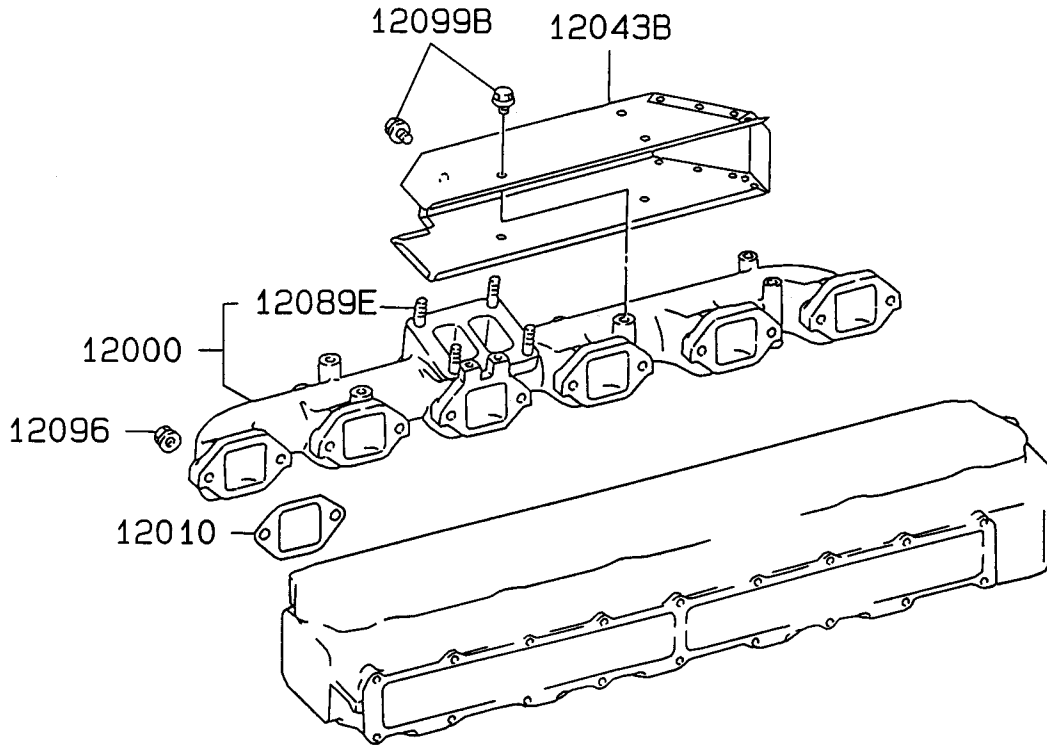

ITEM	PART NUMBER	DESCRIPTION	QTY
12000	0D57030446	MANIFOLD, EXHAUST	1
12010	0D57030447	GASKET, EXHAUST MANIFOLD	6
12043B	0D57030448	INSULATOR, EXHAUST MANIFOLD HEAT	1
12089E	0D57030449	STUD, EXHAUST MANIFOLD	4
12096	0D57030450	NUT, EXHAUST MANIFOLD	12
12099B	0D57030451	BOLT, EXHAUST MANIFOLD	5

7.5L DIESEL — TURBOCHARGER

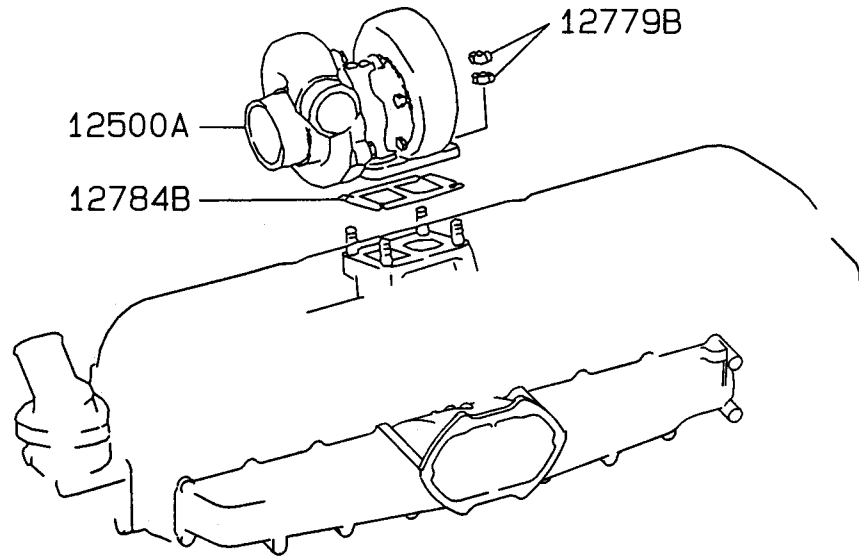

ITEM	PART NUMBER	DESCRIPTION	QTY
12500A	0D57030452	TURBOCHARGER ASSEMBLY	1
12779B	0D57030450	NUT, T/C	4
12784B	0D57030453	GASKET, T/C	1

7.5L DIESEL — EXHAUST PIPE

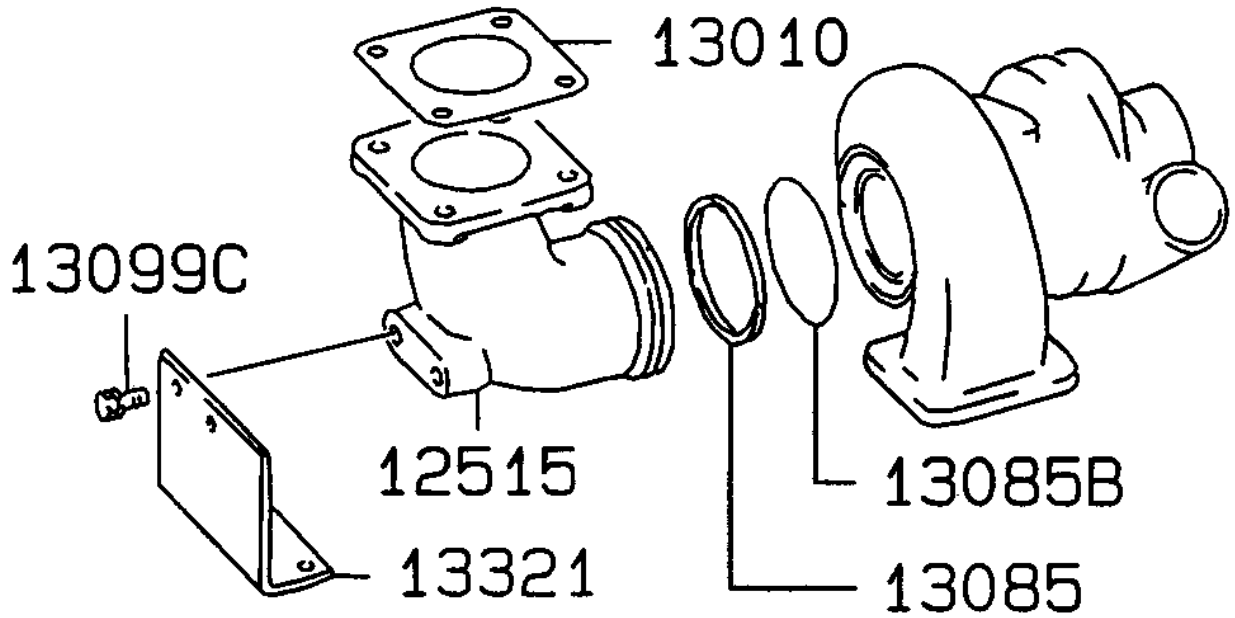

ITEM	PART NUMBER	DESCRIPTION	QTY
12515	0D57030454	COUPLING, T/C TURBINE SIDE	1
13010	0D57030455	GASKET, EXHAUST PIPE	1
13085	0D57030456	SEAL RING, EXHAUST PIPE	1
13085B	0D57030457	SEAL RING, EXHAUST PIPE	1
13099C	0D57030458	BOLT, EXHAUST PIPE	4
13321	0D57030459	SUPPORT, EXHAUST PIPE ELBOW	1

7.5L DIESEL — STARTER

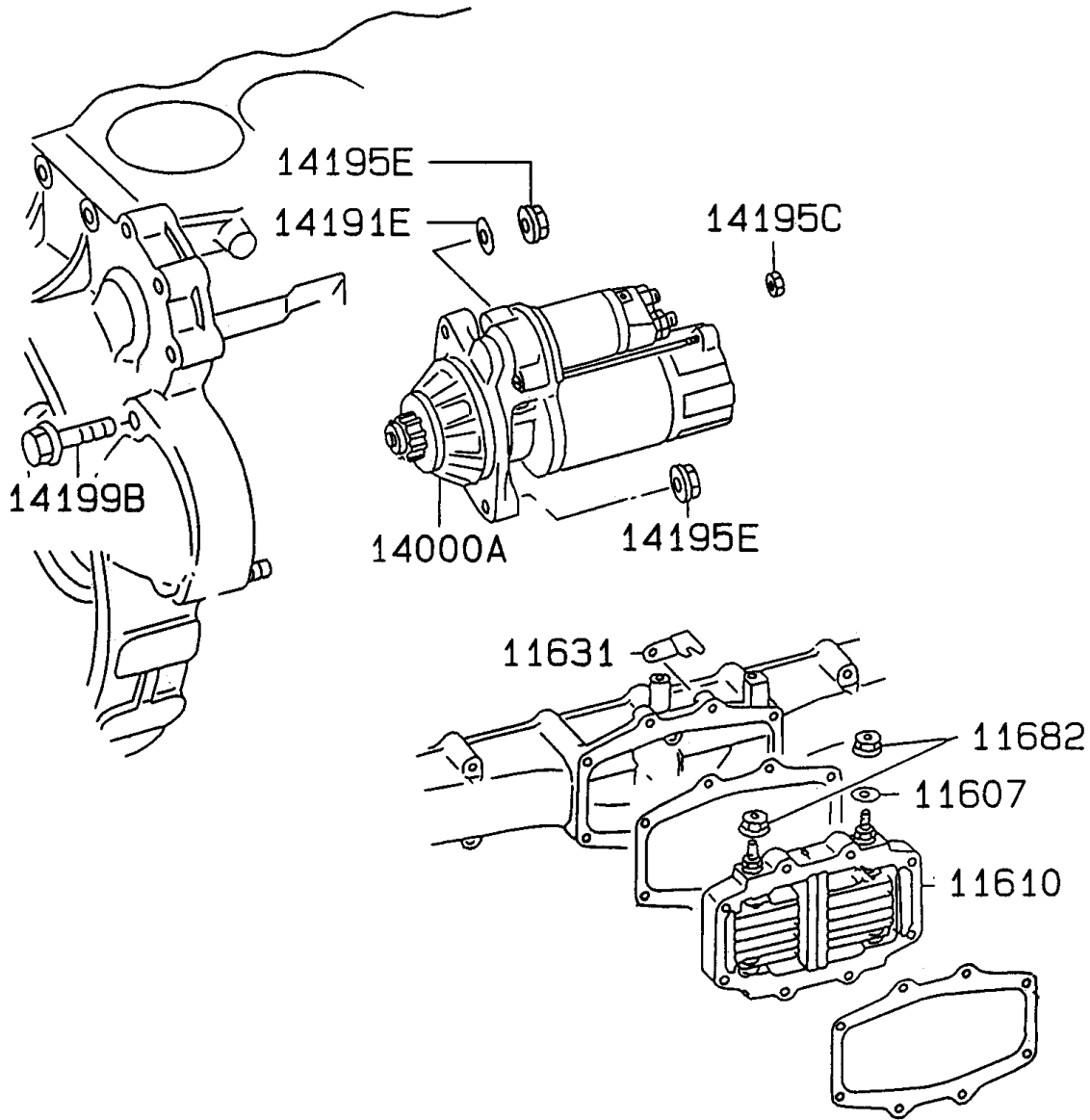

ITEM	PART NUMBER	DESCRIPTION	QTY
11607	OD57030460	WASHER, INTAKE AIR HEATER	1
11610	OD57030461	HEATER, INTAKE AIR	1
11631	OD57030462	PLATE, INTAKE AIR HEATER CABLE EARTH	1
11682	OD57030363	NUT, INTAKE SILENCER	2
14000A	OD57030463	STARTER ASSEMBLY	1
14191E	OD57030464	WASHER, STARTER	1
14195C	OD57030465	NUT, STARTER	1
14195E	OD57030466	NUT, STARTER	2
14199B	OD57030467	BOLT, STARTER	1

7.5L DIESEL — ALTERNATOR

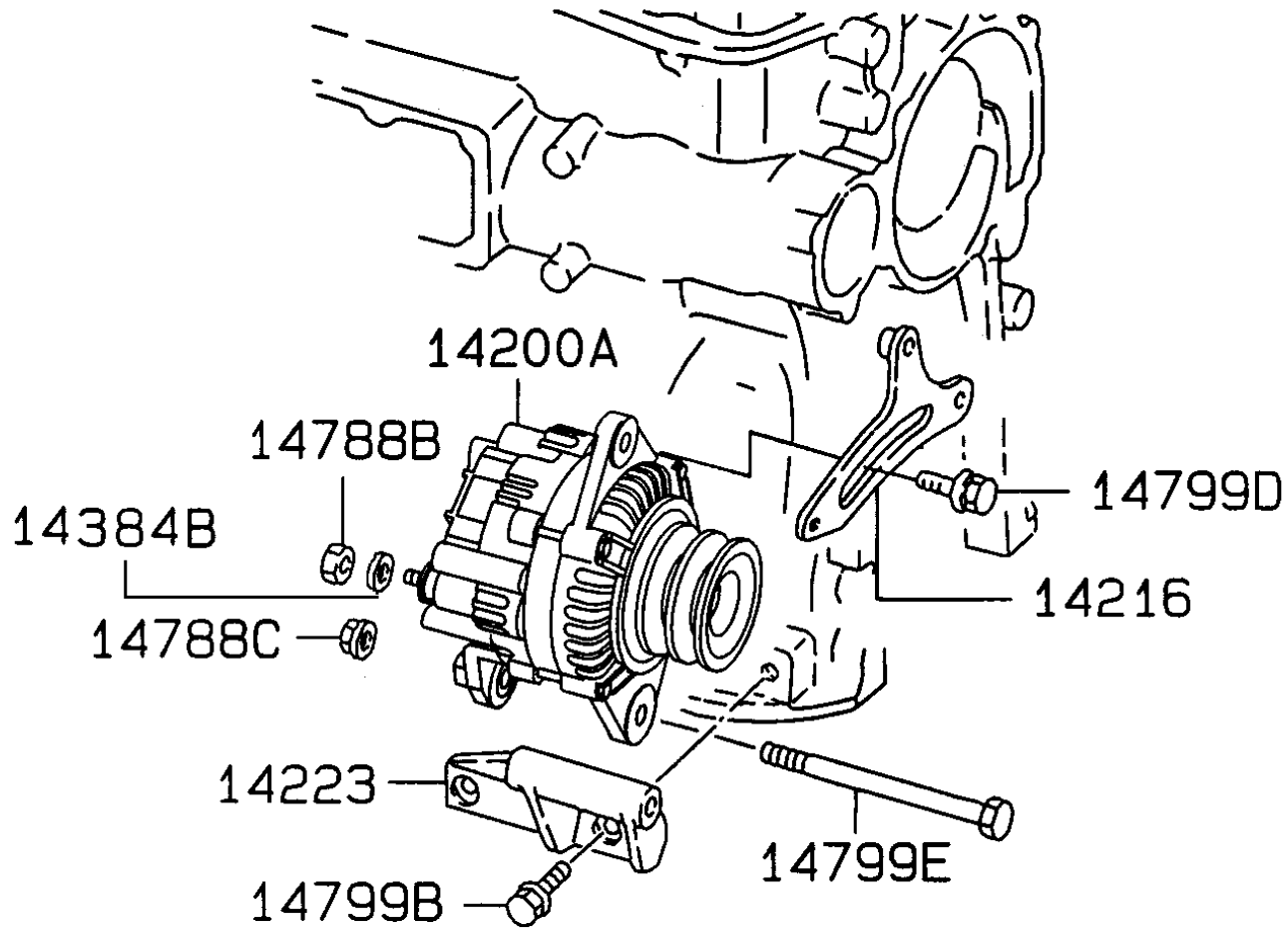

ITEM	PART NUMBER	DESCRIPTION	QTY
14200A	0D57030468	ALTERNATOR ASSEMBLY	1
14216	0D57030469	BRACE, ALTERNATOR ADJUSTING	1
14223	0D57030470	BRACKET, ALTERNATOR MOUNTING	1
14384B	0D57030471	WASHER, ALTERNATOR	1
14788B	0D57030472	NUT, ALTERNATOR	1
14788C	0D57030466	NUT, ALTERNATOR	1
14799B	0D57030160	BOLT, ALTERNATOR	2
14799D	0D57030473	BOLT, ALTERNATOR	1
14799E	0D57030474	BOLT, ALTERNATOR	1

7.5L DIESEL — ENGINE COMMON PARTS

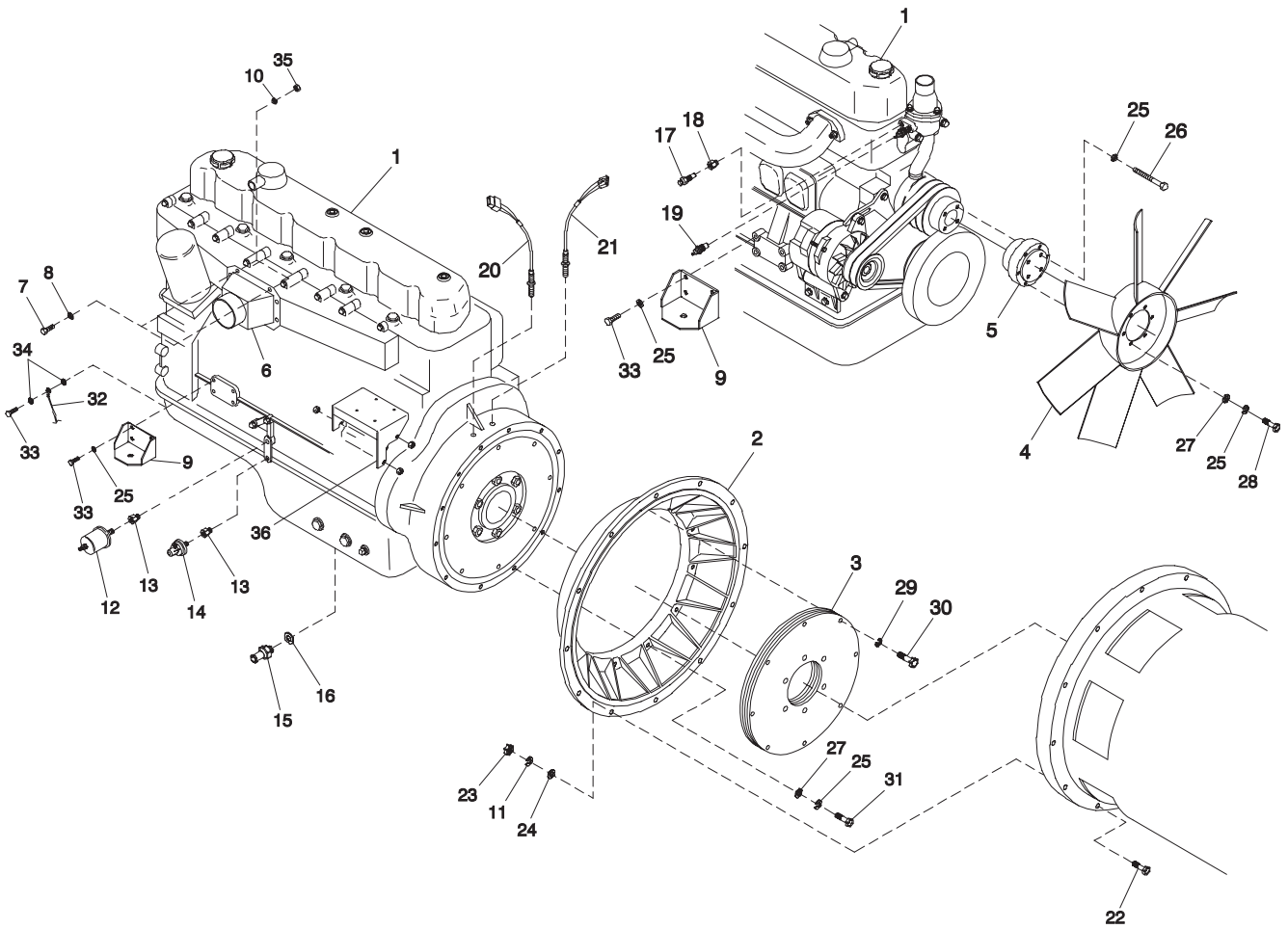

7.5L DIESEL — ENGINE COMMON PARTS

ITEM	PART NUMBER	DESCRIPTION	QTY
1	0D5703	7.5L MITSUBISHI ENGINE	1
2	0D5760	HOUSING, FLYWHEEL ADAPTER MACH 7.5	1
3	021322	PLATE, FLEX SAE 11-1/2	5
4	078417	FAN REWORK 30"	1
5	0D6661	SPACER, COOLING FAN	1
6	0D5341	INTAKE ADAPTER, MACHINED	1
7	051698	SCREW HHC M8-1.25 x 75 G8.8	2
8	022145	WASHER FLAT 5/16 ZINC	2
9	0D8199	ENGINE MOUNT	2
10	022129	WASHER LOCK M8-5/16	2
11	051769	WASHER LOCK M12	16
12	053666	SENDER OIL PRESSURE	1
13	042574	ADAPTOR 1/8 NPTF TO 1/8-28	2
14*	0A8584	SWITCH, OIL PRESSURE	1
15	0D2168	OIL DRAIN M18 x 1.5	1
16	0D4739	WASHER FLAT M18 COPPER 1.5 THK	1
17	053667	SENDER, WATER TEMPERATURE	1
18	065809	ADAPTOR, WATER TEMP SENDER	1
19	035606	SENSOR, HIGH COOLANT SHUTDOWN	1
20	0D2244M	MAGNETIC PICKUP ASSY (3/8-24 MALE)	1
21	0D2244F	MAGNETIC PICKUP ASSY (3/8-24 FEMALE)	1
22	068406	SCREW HHC M12-1.75 x 60 G10.9	12
23	045773	NUT HEX M12-1.75 G8 YEL CHR	8
24	049808	WASHER FLAT M12	8
25	046526	WASHER LOCK M10	22
26	071623	SCREW SHC M10-1.50 x 55 G12.9	4
27	022131	WASHER FLAT 3/8-M10 ZINC	18
28	059981	SCREW HHC M10-1.5 x 30 G10.9	6
29	0D8427	WASHER LOCK M10 RIBBED	8
30	043097	SCREW SHC 3/8-16 x 1 G8.8NZ	8
31	059355	SCREW SHC M10-1.50 x 50 G12.9	12
32	0536210860	GROUND WIRE ASSY	1
33	051756	SCREW HHC M10-1.5 x 20 G8.8	10
34	025507	WASHER SHAKEPROOF EXT 7/16 STL	2
35	045771	NUT HEX M8-1.25 G8 YEL CHR	2
36	0D3936	BRACKET, GOVERNOR	1

* USED FOR C-PANEL ONLY

7.5L DIESEL — ELECTRONIC GOVERNOR

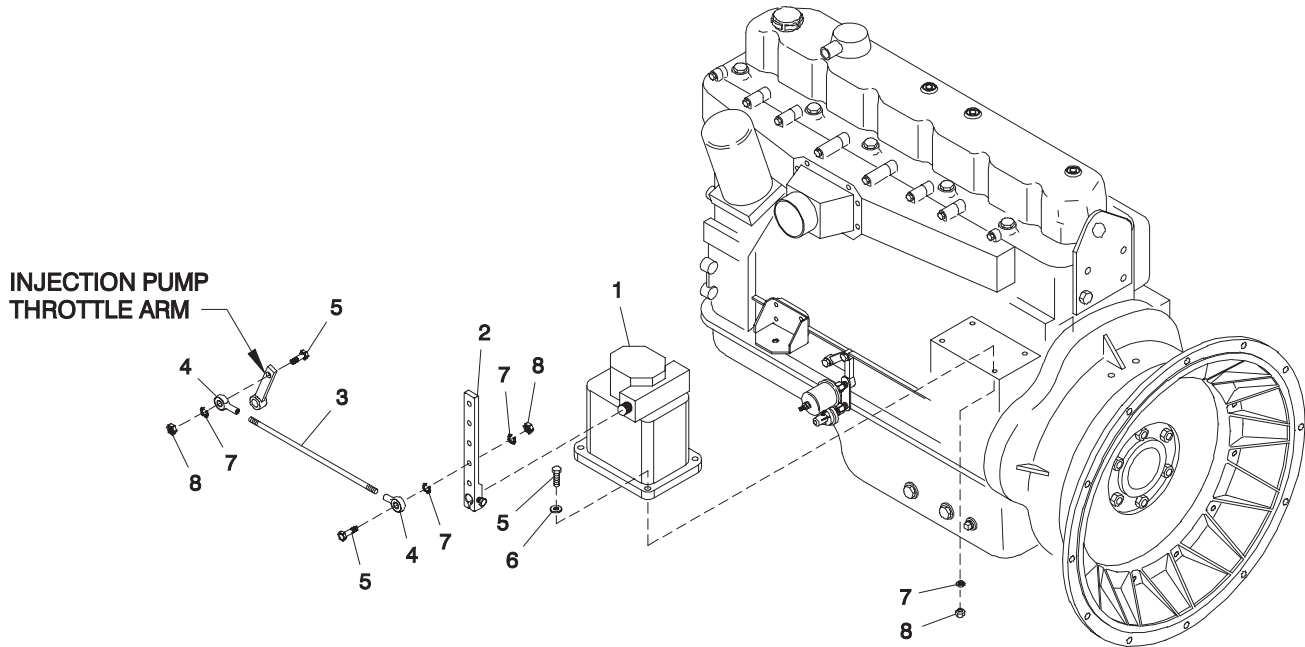

ITEM	PART NUMBER	DESCRIPTION	QTY
1	067708	ACTUATOR 24V CCW	1
2	084753	LEVER ACTUATOR CLAMP	1
3	0D7657	STUD TH 1/4-28 x 15-1/2 G2 ZINC	1
4	084754	ROD, END, BRG 1/4"-28	2
5	038750	SCREW HHC M6-1.0 x 30 G8.8	6
6	049811	WASHER FLAT M6	8
7	022097	WASHER LOCK M6-1/4	6
8	049813	NUT HEX M6 x 1.0 G8 YEL CHR	8

7.5L DIESEL — AIR CLEANER

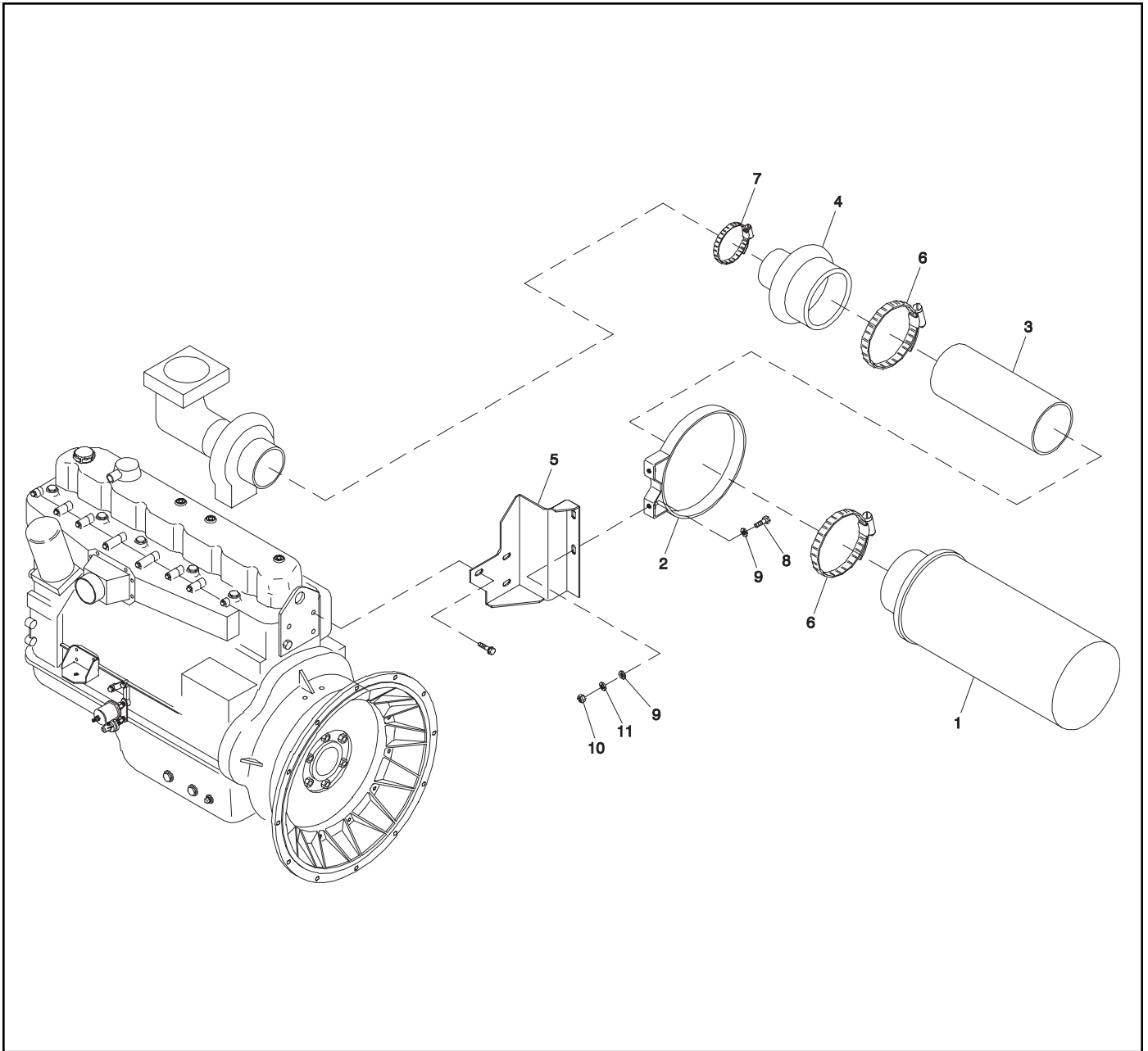

ITEM	PART NUMBER	DESCRIPTION	QTY
1	090625	AIR CLEANER 7 3/4	1
2	090624	MOUNTING CLAMP 7 3/4	1
3	0D6749	INTAKE TUBE 4" OD x 10 LG	1
4	072448	HOSE RUBBER HUMP RDCR 4-2-3/4	1
5	0D6383	BRACKET AIR CLEANER	1
6	086133G	CLAMP HIGH TORQUE 3.75-4.625	2
7	086133D	CLAMP HIGH TORQUE 2.25-3.125	1
8	049814	SCREW HHC M10-1.5 x 25 G8.8	2
9	022131	WASHER FLAT 3/8-M10 ZINC	4
10	045772	NUT HEX M10-1.5 G8 YEL CHR	2
11	046526	WASHER LOCK M10	2

