

# TOSHIBA

# OWNER'S MANUAL

## Wide Plasma Display

COLOR STREAM HD<sup>®</sup>

THEATER WIDE HD<sup>®</sup>

# 42HP82

### Owner's Record

The model number and serial number are on the back of your display. Record these numbers in the spaces below. Refer to these numbers whenever you communicate with your Toshiba dealer about this display.

Model number:

42HP82

Serial number:

# Important Information

## Precautions

Please read this manual carefully before using your TOSHIBA plasma display and keep the manual handy for future reference.

**CAUTION**



**RISK OF ELECTRIC SHOCK  
DO NOT OPEN**



**CAUTION:** TO REDUCE THE RISK OF ELECTRIC SHOCK, DO NOT REMOVE COVER OR BACK. NO USER-SERVICEABLE PARTS INSIDE. REFER SERVICING TO QUALIFIED SERVICE PERSONNEL.

 This symbol warns the user that uninsulated voltage within the unit may have sufficient magnitude to cause electric shock. Therefore, it is dangerous to make any kind of contact with any part inside of this unit.

 This symbol alerts the user that important literature concerning the operation and maintenance of this unit has been included. Therefore, it should be read carefully in order to avoid any problems.

**WARNING**

TO PREVENT FIRE OR SHOCK HAZARDS, DO NOT EXPOSE THIS UNIT TO RAIN OR MOISTURE. ALSO DO NOT USE THIS UNIT'S POLARIZED PLUG WITH AN EXTENSION CORD RECEPTACLE OR OTHER OUTLETS, UNLESS THE PRONGS CAN BE FULLY INSERTED. REFRAIN FROM OPENING THE CABINET AS THERE ARE HIGH-VOLTAGE COMPONENTS INSIDE. REFER SERVICING TO QUALIFIED SERVICE PERSONNEL.

## Warnings and Safety Precaution

The TOSHIBA plasma display is designed and manufactured to provide long, trouble-free service. No maintenance other than cleaning is required. Use a soft dry cloth to clean the panel. Never use solvents such as alcohol or thinner to clean the panel surface.

The plasma display panel consists of fine picture elements (cells). Although TOSHIBA produces the plasma display panels with more than 99.99 percent active cells, there may be some cells that do not produce light or remain lit.

For operating safety and to avoid damage to the unit, read carefully and observe the following instructions. To avoid shock and fire hazards:

1. Provide adequate space for ventilation to avoid internal heat build-up. Do not cover rear vents or install the unit in a closed cabinet or shelves.  
The unit is equipped with cooling fans. If you install the unit in an enclosure, make sure there is adequate space at the top of the unit to allow hot air to rise and escape. If the display becomes too hot, the overheat protector will be activated and the display will be turned off. If this happens, turn off the power to the display and unplug the power cord. If the room where the display is installed is particularly hot, move the display to a cooler location, and wait for the display to cool for 60 minutes. If the problem persists, contact your TOSHIBA dealer for service.
2. Do not use the power cord polarized plug with extension cords or outlets unless the prongs can be completely inserted.
3. Do not expose the unit to water or moisture.
4. Avoid damage to the power cord, and do not attempt to modify the power cord.
5. Unplug the unit during electrical storms or if the unit will not be used over a long period.
6. Do not open the cabinet which has potentially dangerous high voltage components inside. If the unit is damaged in this way the warranty will be void. Moreover, there is a serious risk of electric shock.
7. Do not attempt to service or repair the unit. TOSHIBA is not liable for any bodily harm or damage caused if unqualified persons attempt service or open the back cover. Refer all service to authorized TOSHIBA Service Centers.
8. Use only with the cart, stand, tripod, bracket, or table specified by the manufacturer, or sold with the apparatus. When a cart is used, use caution when moving the cart / apparatus combination to avoid injury from tip-over. Quick stops, excessive force, and uneven surfaces may cause the appliance and cart combination to overturn.



**NOTE:**

When you connect a computer to this display, attach the supplied ferrite cores. If you do not do this, this display will not conform to mandatory FCC standards.

To attach the ferrite cores:

Set the ferrite cores on both ends of the DVI cable (not supplied), and both ends of the power cable (supplied).

Close the lid tightly until the clamps click.

Use the band to fasten the ferrite core (supplied) to the DVI cable.

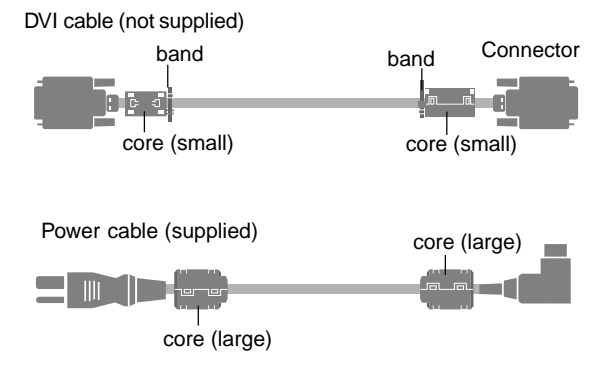

To avoid damage and prolong operating life:

1. Use only with 120V 50/60Hz AC power supply. Continued operation at line voltages greater than 120 Volts AC will shorten the life of the unit, and might even cause a fire hazard.
2. Handle the unit carefully when installing it and do not drop.
3. Set the unit away from heat, excessive dust, and direct sunlight.
4. Protect the inside of the unit from liquids and small metal objects. In case of accident, unplug the unit and have it serviced by an authorized TOSHIBA Service Center.
5. Do not hit or scratch the panel surface as this causes flaws on the surface of the screen.
6. For correct installation and mounting it is strongly recommended to use a trained, authorized TOSHIBA dealer.
7. As is the case with any phosphor-based display (like a CRT monitor, for example) light output will gradually decrease over the life of a Plasma Display Panel.

**Caution**

This Plasma Display radiates infrared rays, therefore it may affect other infrared communication equipment.

Install your infrared sensor in a place away from direct or reflected light from your Plasma display.

Avoid installing this product near electronic equipment that is easy to receive electromagnetic waves.

It may cause interference in image, sound, etc.

In particular, keep video equipment away from this product.

**Recommendations to avoid or minimize phosphor burn-in**

Like all phosphor-based display devices and all other gas plasma displays, plasma displays can be susceptible to phosphor burn under certain circumstances. Certain operating conditions, such as the continuous display of a static image over a prolonged period of time, can result in phosphor burn if proper precautions are not taken. To protect your investment in this TOSHIBA plasma display, please adhere to the following guidelines and recommendations for minimizing the occurrence of image burn:

- Always enable and use your computer's screen saver function during use with a computer input source.
- Display a moving image whenever possible.
- Change the position of the menu display from time to time.
- Always power down the display when you are finished using it.

If the plasma display is in long term use or continuous operation take the following measures to reduce the likelihood of phosphor burn:

- Lower the Brightness and Contrast levels as much as possible without impairing image readability.
- Display an image with many colors and color gradations (i.e. photographic or photo-realistic images).
- Create image content with minimal contrast between light and dark areas, for example, avoid white characters on black backgrounds. Use complementary or pastel color whenever possible.
- Avoid displaying images with few colors and distinct, sharply defined borders between colors.

**Note:**

**Do not allow a still picture to be displayed for an extended period, as this can cause a permanent ghost image to remain on the Wide Plasma Display.**

**Examples of still pictures include logos, video games, computer images, teletext and images displayed in 4:3 mode.**

**Caution**

The plasma display panel is manufactured using an extremely high level of precision technology, however sometimes some parts of the screen may be missing picture elements or have luminous spots. This is not a sign of a malfunction.

# Contents

<b>Important Information .....</b>	<b>2</b>	<b>OSD Controls .....</b>	<b>20</b>
<b>How to Attach Options to the Plasma Display .....</b>	<b>5</b>	Menu Operations .....	20
<b>Introduction .....</b>	<b>6</b>	Picture Settings Menu .....	22
Introduction to the 42HP82 Plasma Display .....	6	Adjusting the picture .....	22
The features you'll enjoy include: .....	6	Setting the picture mode according to the	
Contents of the Package .....	6	brightness of the room .....	23
Options .....	6	Setting the color temperature .....	24
<b>Part Names and Function .....</b>	<b>7</b>	Adjusting the color to the desired quality .....	25
Front View .....	7	Reducing noise in the picture .....	26
Rear View / Terminal Board .....	8	Sound Settings Menu .....	27
Remote Controller .....	9	Adjusting the treble, bass and left/right balance .....	27
Battery Installation and Replacement .....	10	Screen Settings Menu .....	28
Using the wired remote control mode .....	11	Adjusting the Position, Size, Fine Picture,	
Operating Range .....	11	Picture Adj .....	28
Handling the remote controller .....	11	Function Settings Menu .....	29
<b>Installation .....</b>	<b>12</b>	Setting the on-screen display .....	29
Connecting Your PC .....	13	Adjusting the position of the menu display .....	30
Connections with Equipment that has a Digital Interface .....	13	Setting the power management for computer images .....	31
Connecting Your VCR .....	13	POWER/STANDBY indicator .....	32
Connecting Your DVD Player .....	13	Setting the gray level for the sides of the screen .....	33
External Speaker Connections .....	14	Setting the picture to suit the movie .....	33
Pin Assignments and Signal Levels		Setting RGB3 ADJ. ....	34
for 15-pin RGB (Analog) .....	15	Reducing burn-in of the screen .....	34
Pin Configuration and Signal		Setting the time for "INVERSE" .....	35
of the RGB 3 IN Connector (DVI Connector) .....	15	Setting the time for "SCREEN WIPER" .....	36
<b>Basic Operations .....</b>	<b>16</b>	Resetting to the default values .....	37
POWER .....	16	Options Settings Menu .....	38
To turn the unit ON and OFF .....	16	Setting the allocation of the audio connectors .....	38
VOLUME .....	16	Setting the BNC connectors .....	39
To adjust the volume .....	16	Setting a computer image to the correct RGB	
MUTE .....	16	select screen .....	39
To cancel the sound .....	16	Setting high definition images to the suitable	
DISPLAY .....	16	screen size .....	40
To check the settings .....	16	Information Menu .....	41
DIGITAL ZOOM .....	16	Checking the frequencies, polarities of input signals,	
OFF TIMER .....	17	and resolution .....	41
To set the off timer .....	17	Setting the language for the menus .....	41
To check the remaining time .....	17	Setting the video signal format .....	42
To cancel the off timer .....	17	<b>Table of Signals Supported .....</b>	<b>43</b>
<b>WIDE Operations .....</b>	<b>18</b>	Supported resolution .....	43
Watching with a wide screen (manual) .....	18	<b>Troubleshooting .....</b>	<b>45</b>
When watching VCR's or DVD .....	18	<b>Specifications .....</b>	<b>46</b>
When watching high definition video source .....	18	<b>FCC Statement .....</b>	<b>47</b>
Watching computer images with a wide screen .....	19	<b>Limited United States Warranty</b>	
		<b>for Wide Plasma Display .....</b>	<b>48</b>
		<b>Limited Canada Warranty</b>	
		<b>for Wide Plasma Display .....</b>	<b>49</b>

# How to Attach Options to the Plasma Display

You can attach your optional mounts or stand to the plasma display in one of the following two ways:

- While it is upright. (See Drawing A)
- As it is laid down with the screen face down (See Drawing B). Lay the protective sheet, which was wrapped around the display when it was packaged, beneath the screen surface so as not to scratch the screen face.

- **This device cannot be installed on its own. Be sure to use a stand or original mounting unit. (Wall hanging bracket, Pedestal, etc.) See page 6.**
- **For correct installation and mounting it is strongly recommended to use a trained, authorized TOSHIBA dealer.**  
**Failure to follow correct mounting procedures could result in damage to the equipment or injury to the installer.**  
**Product warranty does not cover damage caused by improper installation.**

- **Use only Listed Cart or Stand, or mounting kit or stand provided by manufacturer.**

Drawing A

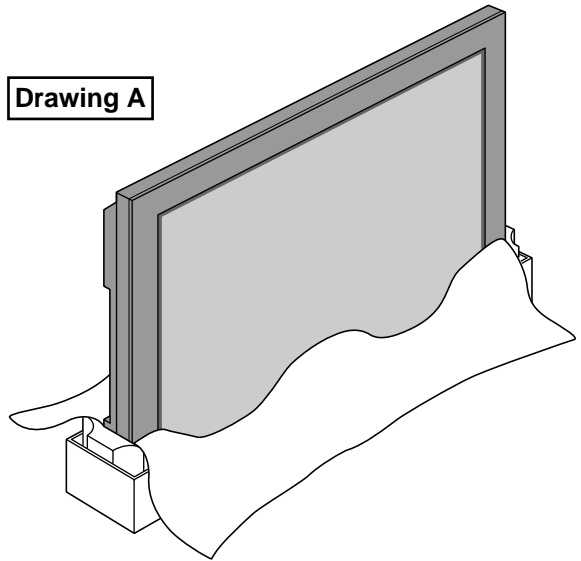

Drawing B

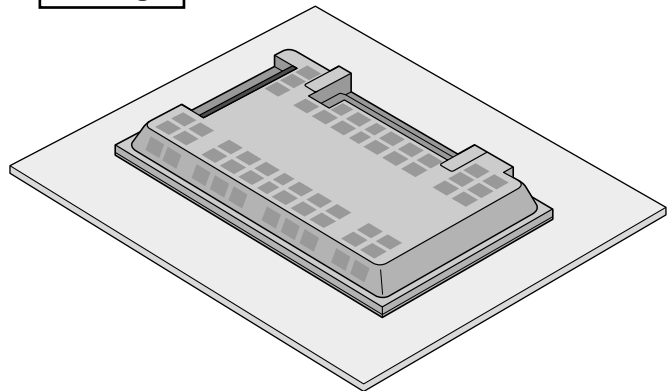

## Ventilation Requirements for enclosure mounting

To allow heat to disperse, leave space between surrounding objects as shown on the diagram at right when installing.

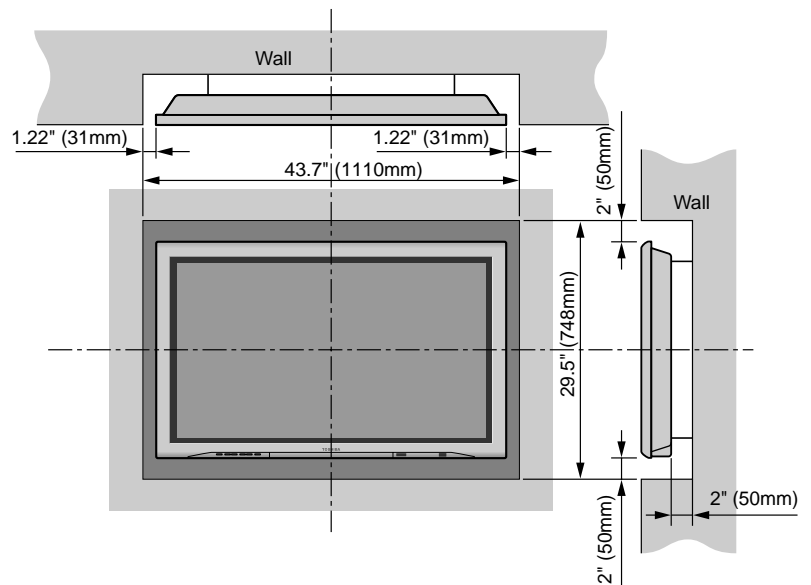

# Introduction

---

## Introduction to the 42HP82 Plasma Display

TOSHIBA's 42HP82 Plasma Display is a seamless blend of cutting-edge visual technology and sophisticated design. At 42 inches, with a 16:9 aspect ratio, the 42HP82 certainly makes a big impression. However, at a mere 3.5 inches/89 mm thin, the display's sleek techno-art lines blend in well with your environment. The plasma display's crisp, vivid image quality will transform data from any graphic medium- from PCs to DVD players- into art. And weighing only 65 lbs / 29.5 kg, it actually can be hung almost anywhere. TOSHIBA has made sure that a host of multimedia resources can be connected easily and displayed as brilliantly as intended on the Plasma Display.

## The features you'll enjoy include:

- 42-inch screen
- 16:9 aspect ratio
- Black Stripe
- The enhanced display in red uses a two-stage filtering system where Color Filter is combined.
- 3.5 inch / 89 mm thin
- 65 lbs / 29.5 kg light
- High-resolution screen: 1024×768 pixels
- 160-degrees of off-axis viewing, horizontally and vertically.
- Flicker- and warp-free display provides excellent image geometry, even in screen corners.
- Not affected by magnetic fields; no color drift or edge distortion.
- VGA, SVGA, XGA, SXGA, UXGA computer signal compatibility
- NTSC, PAL, SECAM, composite and S-Video signal compatibility
- 480P, 1080I, 720P and HDTV signal compatibility
- PC, VCR and DVD player source compatibility
- Progressive scan conversion automatically converts VGA, SVGA, SXGA and UXGA signals to the panel's native resolution
- Progressive Scan method is employed.
- RGB input (3\*), Video input (3\*), DVD/HD input (2\*), Audio input (3), External Control input (1)
- Color Filter control system provides user selectable on-screen color temperature settings
- New Drive Technology
- Component video input terminal for DVD, 15.75kHz (Y, CB, CR)
- Digital broadcasting source compatibility
- OSD menu-driven on-screen control system that makes image adjustments a snap
- Seven languages (English, German, French, Italian, Spanish, Swedish, and Chinese)

\* You can select RGB source, Component source or Video source for the 5BNC terminal. When selecting an RGB input, the source is switched to the RGB input (3); when selecting a component input, the source is switched to the DVD/HD input (2); when selecting a Video source, the source is switched to the Video input (3).

## Contents of the Package

- 42HP82 plasma display
- Power cord
- RGB cable (Mini D-Sub 15-pin to Mini D-Sub 15-pin connector)
- Remote controller with two AAA Batteries
- Owner's manual
- Remote cable
- Safety metal fittings\*\*
- Screws for safety metal fittings\*\*
- Ferrite core (small×2, large×2), band
- BNC-RCA Adapter (×3)

\*\*These are fittings for fastening the unit to a wall to prevent tipping due to external shock when using the stand (option). Fasten the safety fittings to the holes in the back of the display using the safety fitting mount screws.

## Options

- Wall hanging bracket (angled)
- Wall hanging bracket (vertical)
- Pedestal
- Speakers

# Part Names and Function

## Front View

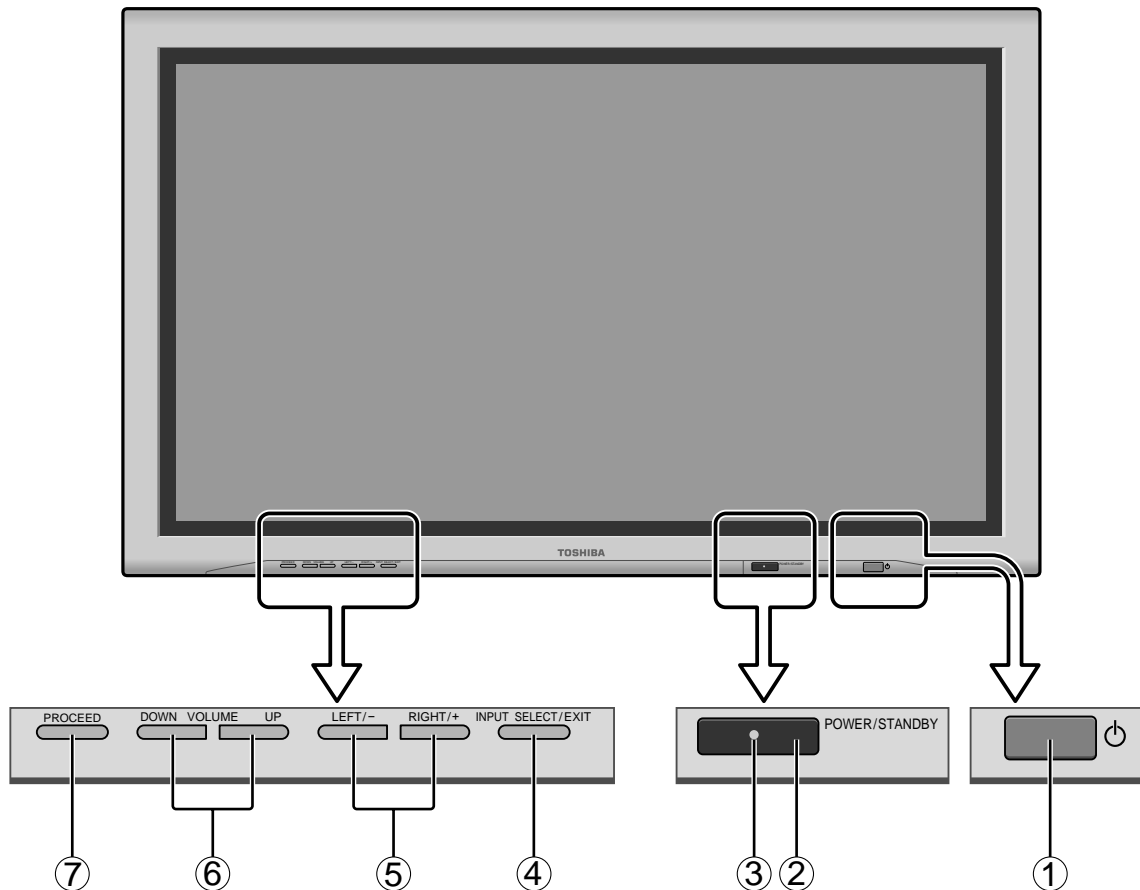

- ① **Power**  
Turns the display's power on and off.
- ② **Remote sensor window**  
Receives the signals from the remote controller.
- ③ **POWER/STANDBY indicator**  
When the power is on ..... Lights green.  
When the power is in the standby mode ... Lights red.
- ④ **INPUT SELECT / EXIT**  
Switches the input, in the following order.  
The available inputs depend on the setting of "BNC SELECT".  
RGB:    [ → VIDEO1 → VIDEO2 → HD/DVD/DTV    ]  
          [ RGB/PC3 ← RGB/PC2 ← RGB/PC1 ← ]  
COMP.:   [ → VIDEO1 → VIDEO2 → HD1/DVD1/DTV1    ]  
          [ RGB/PC3 ← RGB/PC1 ← HD2/DVD2/DTV2 ← ]  
VIDEO:   [ → VIDEO1 → VIDEO2 → VIDEO3            ]  
          [ RGB/PC3 ← RGB/PC1 ← HD/DVD/DTV ← ]
- ⑤ **LEFT/- and RIGHT/+**  
Enlarges or reduces the image. Functions as the CURSOR (◀/▶) buttons in the On-Screen Display (OSD) mode.
- ⑥ **VOLUME DOWN and UP**  
Adjusts the volume. Functions as the CURSOR (▲/▼) buttons in the On-Screen Display (OSD) mode.
- ⑦ **PROCEED**  
Sets the On-Screen Display (OSD) mode and displays the main menu.

Functions as the EXIT buttons in the On-Screen Display (OSD) mode.

## Rear View/ Terminal Board

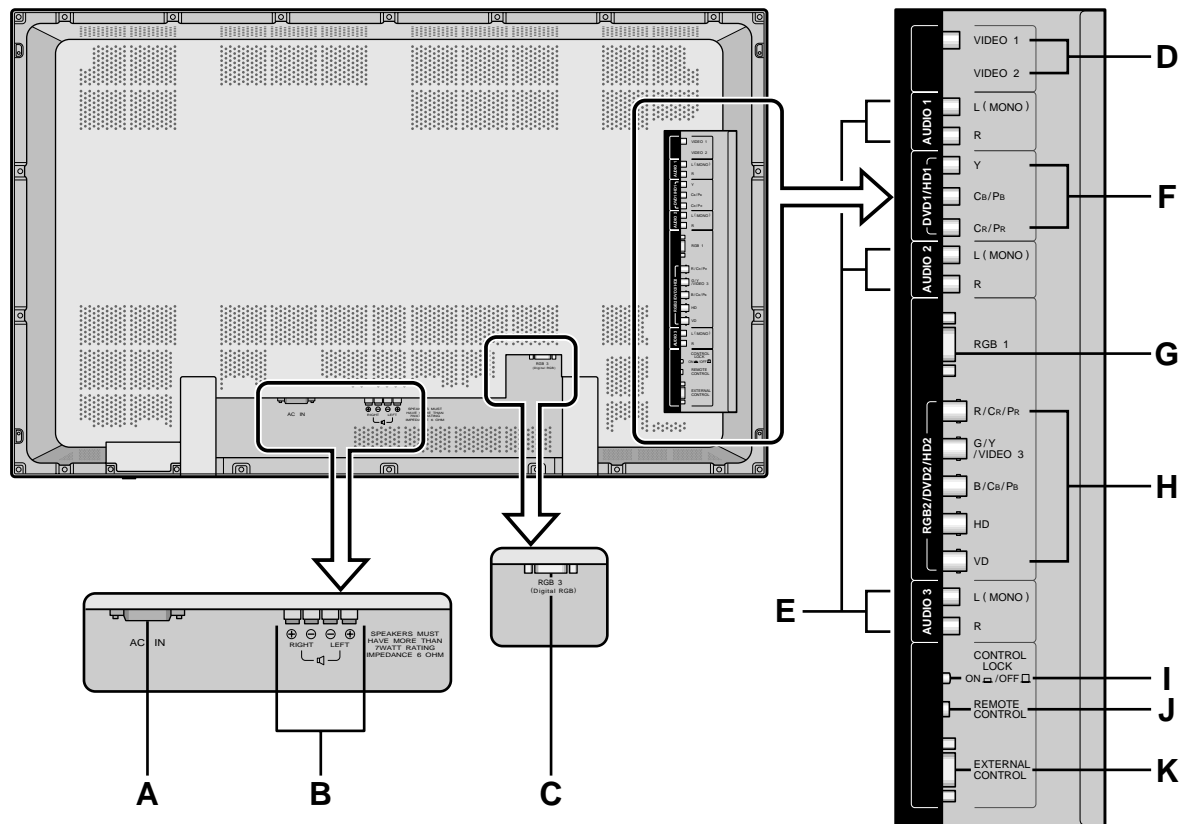

### A AC IN

Connect the included power cord here.

### B EXT SPEAKER L and R

Connect speakers here. Maintain the correct polarity.

### C RGB3 (DVI 29pin)

Inputs a digital RGB signal (TMDS).

### D VIDEO1, 2

Connect VCR's or DVD's, etc. here.

### E AUDIO1, AUDIO2, AUDIO3

These are audio input terminals.

The input is selectable. Set which video image to allot them to on the menu screen.

### F DVD1 / HD1

Connect DVD's or High Definition equipments, etc. here.

### G RGB1

Inputs the analog RGB signal of personal computer, etc.

### H RGB2/ DVD2/ HD2

RGB2: Inputs the analog RGB signal.

DVD2/ HD2: Connect DVD's or High Definition equipments, etc. here.

VIDEO3: Connect VCR's or DVD's, etc. here.

### I CONTROL LOCK

When "CONTROL LOCK" is set "ON", the buttons on the set's control panel do not function.

### J REMOTE CONTROL

Connect the supplied remote cable here.

### K EXTERNAL CONTROL

This terminal is used when power ON/OFF, input selection and AUDIO MUTE and other controls are operated externally (by external control).



## Remote Controller

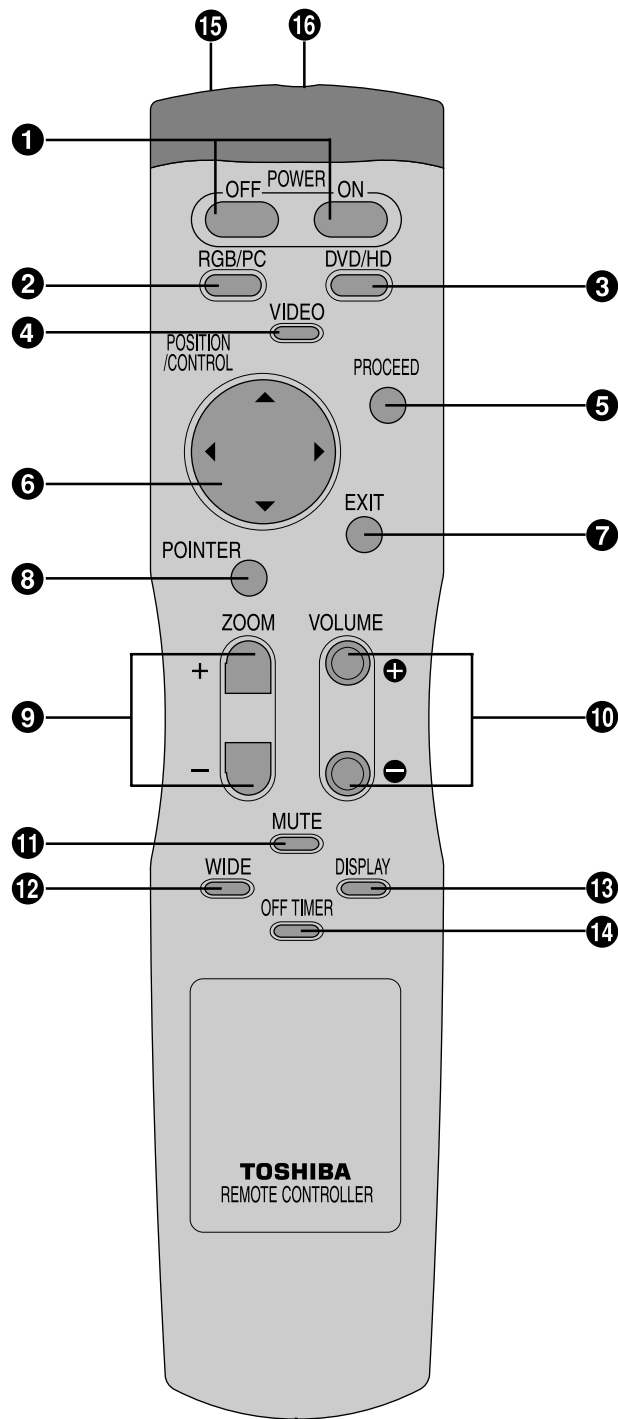

### 1 POWER ON/OFF

Switches Power ON/OFF.  
(This does not operate when POWER/STANDBY indicator of the main unit is off.)

### 2 RGB/PC

Press this button to select RGB/PC as the source.  
The available sources depend on the setting of "BNC SELECT".

RGB: → RGB/PC1 → RGB/PC2 → RGB/PC3

COMP. or VIDEO: → RGB/PC1 → RGB/PC3

RGB/PC can also be selected using the INPUT SELECT button on the display.

### 3 DVD / HD

Press this button to select DVD/HD as the source.  
The available sources depend on the setting of "BNC SELECT".

RGB or VIDEO: HD/DVD/DTV

COMP.: → HD1/DVD1/DTV1 → HD2/DVD2/DTV2

DVD/HD can also be selected using the INPUT SELECT button on the display.

### 4 VIDEO

Press this button to select VIDEO as the source.  
The available sources depend on the setting of "BNC SELECT".

VIDEO: → VIDEO1 → VIDEO2 → VIDEO3

RGB or COMP.: → VIDEO1 → VIDEO2

VIDEO can also be selected using the INPUT SELECT button on the display.

### 5 PROCEED

Press this button to access the OSD controls.  
Press this button during the display of the main menu to go to the sub menu.

### 6 CURSOR (▲ / ▼ / ◀ / ▶)

Use these buttons to select items or settings and to adjust settings or switch the display patterns.

### 7 EXIT

Press this button to exit the OSD controls in the main menu. Press this button during the display of the sub menu to return to the main menu.

### 8 POINTER

Press this button to display the pointer.

### 9 ZOOM (+ / -)

Enlarges or reduces the image.

### 10 VOLUME (+ / -)

Adjusts the volume.

### 11 MUTE

Mutes the sound.

**12 WIDE**

The type of broadcast is detected automatically, and the recommended wide screen is set.

**13 DISPLAY**

Displays the source settings on the screen.

**14 OFF TIMER**

Activates the off timer for the unit.

**15 Remote control signal transmitter**

Transmits the remote control signals.

**16 Remote Jack**

Insert the plug of the supplied remote cable here when using the supplied remote controller in the wired condition.

**Battery Installation and Replacement**

Insert the 2 “AAA” batteries, making sure to set them in with the proper polarity.

1. Press and open the cover.

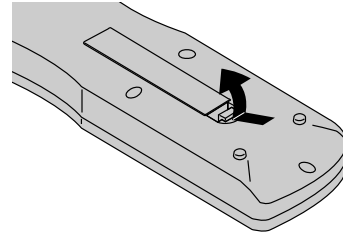

2. Align the batteries according to the (+) and (-) indication inside the case.

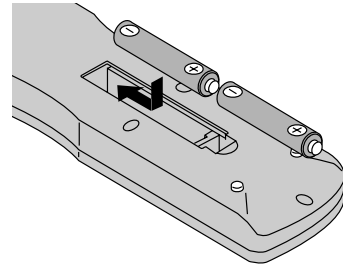

3. Replace the cover.

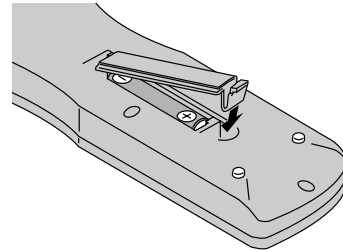

## Using the wired remote control mode

Connect the supplied remote cable to the remote controller's remote jack and the "REMOTE CONTROL" terminal on the display.

When the cable is connected, the mode automatically switches to wired remote control. When the wired remote control mode is used, the remote controller can be operated even if no batteries are loaded.

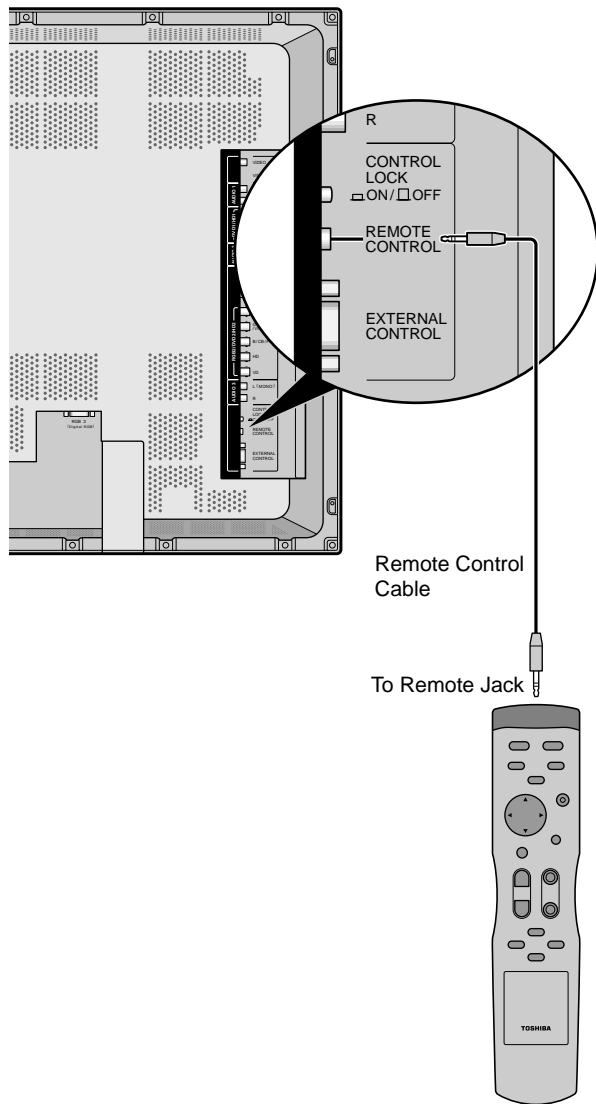

## Operating Range

- Use the remote controller within a distance of about 23ft / 7 m. from the front of the display's remote control sensor and at horizontal and vertical angles of up to approximately 30°.
- The remote control operation may not function if the display's remote control sensor is exposed to direct sunlight or strong artificial light, or if there is an obstacle between the sensor and the remote controller.

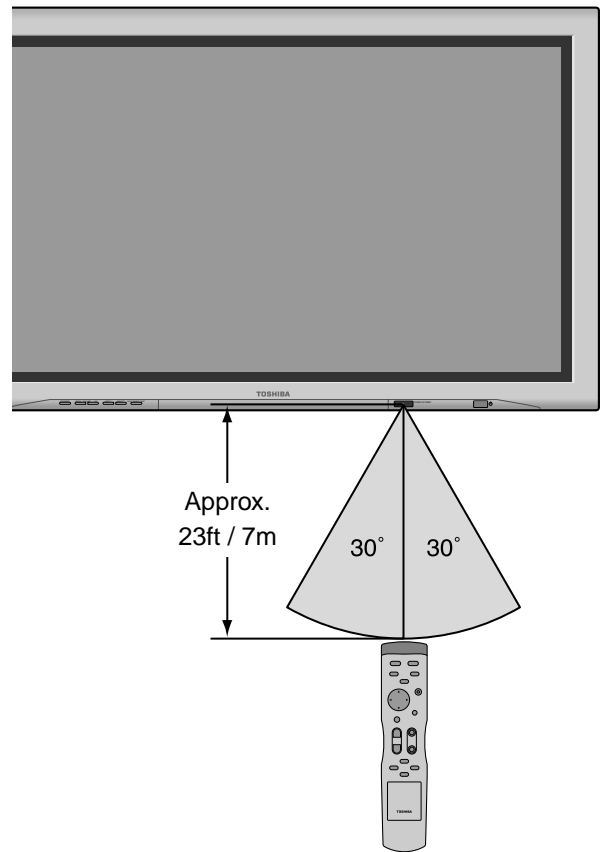

## Handling the remote controller

- Do not drop or mishandle the remote controller.
- Do not get the remote controller wet. If the remote controller gets wet, wipe it dry immediately.
- Avoid heat and humidity.
- When not using the remote controller for a long period, remove the batteries.
- Do not use new and old batteries together or use different types together.
- Do not take apart the batteries, heat them, or throw them into a fire.
- When using the remote controller in the wireless condition, be sure to unplug the remote cable from the REMOTE CONTROL terminal on the display.

# Installation

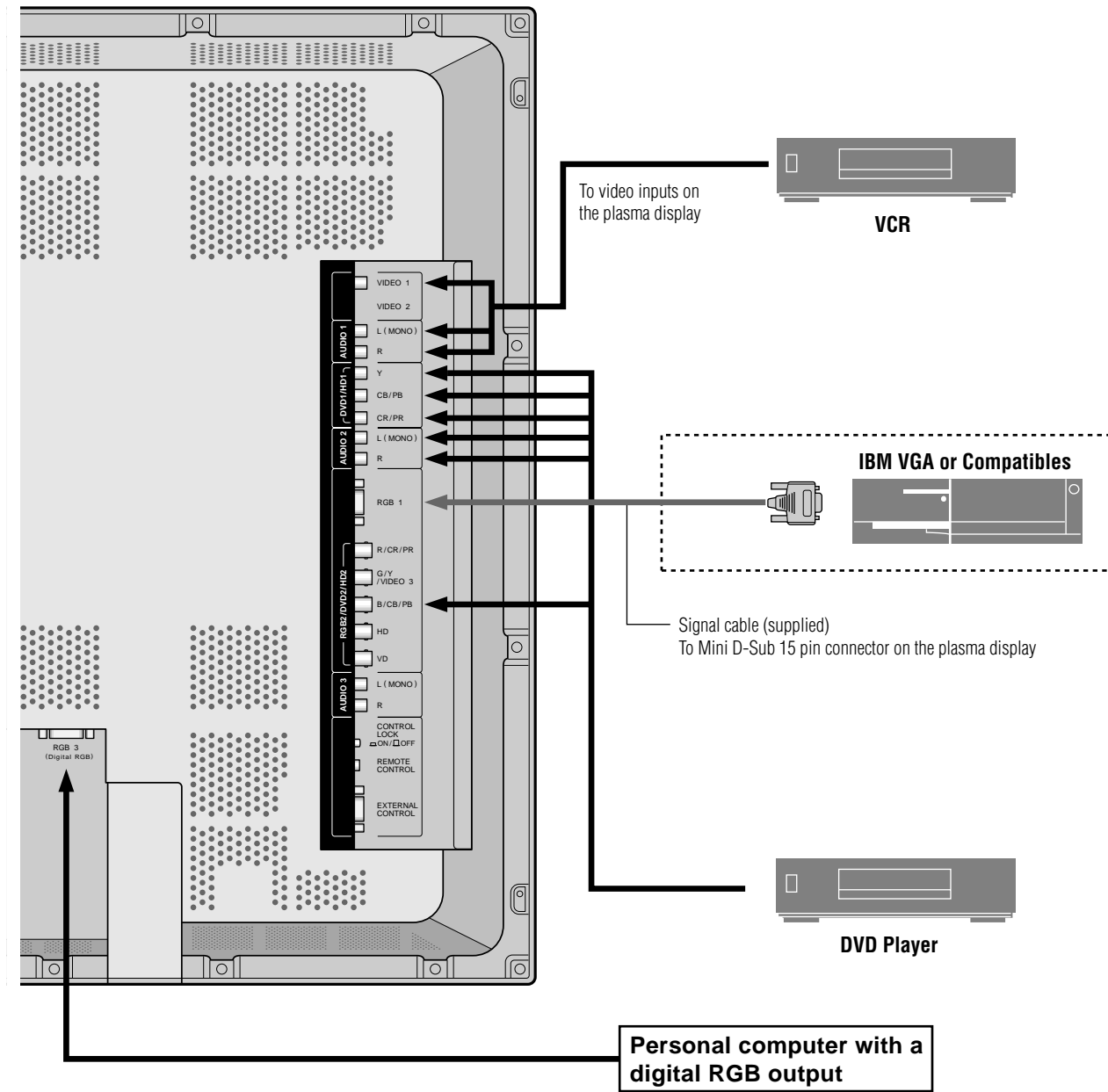

---

## Connecting Your PC

Connecting your PC to your plasma display will enable you to display your computer's screen image for an impressive presentation. The plasma display supports the signals described on page 43.

To connect a PC or compatible graphics adapter:

1. Turn off the power to your plasma display and computer.
2. If your PC does not support SXGA/XGA/SVGA/VGA, you will need to install an SXGA/XGA/SVGA/VGA graphics board. Consult your computer's owner's manual for your SXGA/XGA/SVGA/VGA configuration. If you need to install a new board, see the manual that comes with your new graphics board for installation instructions.
3. The plasma display provides signal compatibility up to VESA 1600 × 1200 (UXGA). However, it is not recommended to use this resolution due to image readability on the display's 1024 × 768 native pixel resolution panel.
4. Use the signal cable that's supplied to connect your PC to the plasma display.
5. Turn on the plasma display and the computer.
6. If the plasma display goes blank after a period of inactivity, it may be caused by a screen saver installed on the computer you've connected to the plasma display.

## Connections with Equipment that has a Digital Interface

Connections can be made with equipment that is equipped with a digital interface compliant with the DVI (Digital Visual Interface) standard.

- Use a DVI 29-pin signal cable and the ferrite cores (supplied) when making connections to the RGB3 IN (DVI) connector of the main unit.

Note that the RGB3 IN(DVI) terminal does not support analog RGB input source.

### **Note:**

1. *Input TMDS signals conforming to DVI standards. The TMDS input corresponds to single link.*
2. *To maintain display quality, use a cable with a quality prescribed by DVI standards that is within 5 meters in length.*

## Connecting Your VCR

Use common RCA cables (not provided) to connect your VCR to your plasma display. To make these connections:

1. Turn off the power to your plasma display and VCR.
2. Connect one end of your RCA cable to the video output connector on the back of your VCR; connect the other end to the Video input on your plasma display. Use standard RCA audio patch cords to connect the audio from your VCR to your plasma display (if your VCR has this capability). Be careful to keep the right and left channel connections correct for stereo sound.
3. Turn on the plasma display and the VCR.

**Note:** *Refer to your VCR owner's manual for more information about your equipment's video output requirements.*

## Connecting Your DVD Player

To connect your plasma display to a DVD player:

1. Turn off the power to your plasma display and DVD player.
2. Use a standard video cable to connect your DVD player to the Y, Cb, and Cr inputs on your plasma display. Or use the DVD-player's S-Video output. Use a standard S-Video cable to connect to the S-Video input on the plasma display.
3. Turn on the plasma display and the DVD player.



## Pin Assignments and Signal Levels for 15-pin RGB (Analog)

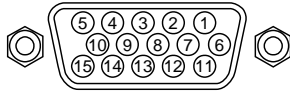

Pin No.	Signal (Analog)
1	Red
2	Green or sync-on-green
3	Blue
4	No connection
5	Ground
6	Red ground
7	Green ground
8	Blue ground
9	No connection
10	Sync signal ground
11	No connection
12	Bi-directional DATA (SDA)
13	Horizontal sync or Composite sync
14	Vertical sync
15	Data clock

## Pin Configuration and Signal of the RGB 3 IN Connector (DVI Connector)

The unit is equipped with a type of connector commonly used for both analog and digital.

(Functionally, this cannot be used for an analog input.)

(TMDS can be used for single link only.)

### RGB 3

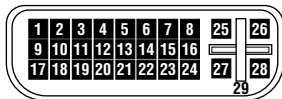

Pin No.	Signal (Digital)
1	T.M.D.S Data 2 -
2	T.M.D.S Data 2 +
3	T.M.D.S Data 2 Shield
4	No connection
5	No connection
6	DDC Clock
7	DDC Data
8	No connection
9	T.M.D.S Data 1 -
10	T.M.D.S Data 1 +
11	T.M.D.S Data 1 Shield
12	No connection
13	No connection
14	+5V Power
15	Ground
16	Hot Plug Detect
17	T.M.D.S Data 0 -
18	T.M.D.S Data 0 +
19	T.M.D.S Data 0 Shield
20	No connection
21	No connection
22	T.M.D.S Clock Shield
23	T.M.D.S Clock +
24	T.M.D.S Clock -
25	No connection
26	No connection
27	No connection
28	No connection
29	No connection

# Basic Operations

---

## POWER

### To turn the unit ON and OFF:

1. Plug the power cord into an active AC power outlet.
2. Press the POWER ON button to turn on the unit.  
The display's POWER/STANDBY indicator will light up (green) when the unit is on.
3. Press the POWER OFF button (on the remote controller or the unit) to turn off the unit.  
The display's POWER/STANDBY indicator turns red and the standby mode is set (only when turning off the unit with the remote controller).

## VOLUME

### To adjust the volume:

1. Press and hold the VOLUME  $\oplus$  button (on the remote controller or the unit) to increase to the desired level.
2. Press and hold the VOLUME  $\ominus$  button (on the remote controller or the unit) to decrease to the desired level.

## MUTE

### To cancel the sound:

Press the MUTE button on the remote controller to cancel the sound; press again to restore.

## DISPLAY

### To check the settings:

1. The screen changes each time the DISPLAY button is pressed.
2. If the button is not pressed for approximately three seconds, the menu turns off.

## DIGITAL ZOOM

Digital zoom specifies the picture position and enlarges the picture.

1. Press the POINTER button to display the pointer. (  )

### To change the size of the picture:

Press the ZOOM+ button and enlarge the picture.  
The pointer will change to resemble a magnifying glass. (  )  
A press of the ZOOM- button will reduce the picture and return it to its original size.

### To change the picture position:

Select the position with the  $\blacktriangle$  $\blacktriangledown$  $\blacktriangleleft$  $\blacktriangleright$  buttons.

2. Press the POINTER button to delete the pointer.



---

## OFF TIMER

### To set the off timer:

The off timer can be set to turn the power off after 30, 60, 90 or 120 minutes.

1. Press the OFF TIMER button to start the timer at 30 minutes.
2. Press the OFF TIMER button to the desired time.
3. The timer starts when the menu turns off.

→ 30 → 60 → 90 → 120 → 0

OFF TIMER 30



### To check the remaining time:

1. Once the off timer has been set, press the OFF TIMER button once.
2. The remaining time is displayed, then turns off after a few seconds.
3. When five minutes remain, the remaining time appears until it reaches zero.

OFF TIMER 28



### To cancel the off timer:

1. Press the OFF TIMER button twice in a row.
2. The off timer is canceled.

OFF TIMER 0



### Note:

*After the power is turned off with the off timer, a slight current is still supplied to the display. When you are leaving the room or do not plan to use the system for a long period of time, turn off the power of the display.*

# WIDE Operations

## Watching with a wide screen (manual)

With this function, you can select one of four screen sizes.

### When watching VCR's or DVD

1. Press the WIDE button on the remote controller.

2. *Within 3 seconds ...*

Press the WIDE button again.

The screen size switches as follows:



### ZOOM size screen

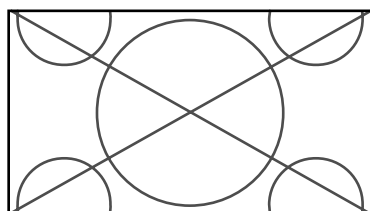

The picture is expanded in the horizontal and vertical direction, maintaining the original proportions.

- Use this for theater size (wide) movies, etc.

### NORMAL size screen (4:3)

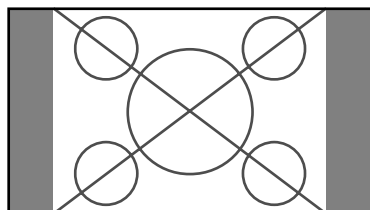

The normal size screen is displayed.

- The picture has the same size as video pictures with a 4:3 aspect ratio.

### FULL size screen

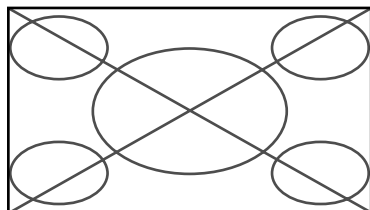

The image is expanded in the horizontal direction.

- Images compressed in the horizontal direction (“squeezed images”) are expanded in the horizontal direction and displayed on the entire screen. (Normal images are expanded in the horizontal direction.)

### JUST size screen

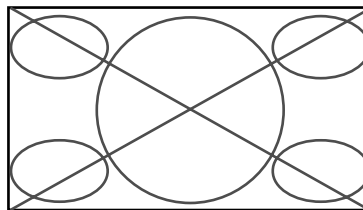

The picture is expanded in the horizontal and vertical directions at different ratios.

- Use this for watching normal video programs (4:3) with a wide screen.

### When watching high definition video source

1. Press the WIDE button on the remote controller.

### FULL size screen (16:9)

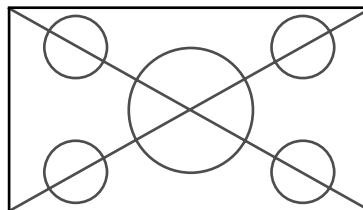

The full size screen is displayed.

- The picture has the same size as video pictures (16:9).

## Watching computer images with a wide screen

Switch to the wide screen mode to expand the 4:3 image to fill the entire screen.

1. Press the WIDE button on the remote controller.

2. *Within 3 seconds ...*

Press the WIDE button again.

The screen size switches as follows:

→ NORMAL → FULL ←

NORMAL size screen (4:3 or SXGA 5:4)

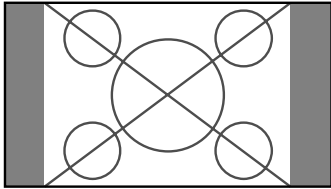

The picture has the same size as the normal computer image.

FULL size screen

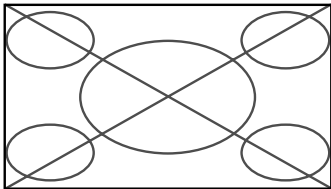

The image is expanded in the horizontal direction.

When wide signals are input.

FULL size screen

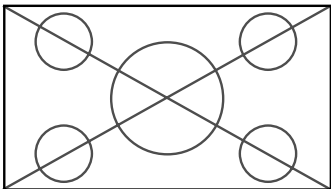

### Information

#### ■ Supported resolution

See page 43 for details on the display output of the various VESA signal standards supported by the display.

■ **When 852 (848) dot × 480 line wide VGA\* signals with a vertical frequency of 60 Hz and horizontal frequency of 31.7 (31.0) kHz are input**

Select an appropriate setting for RGB SELECT mode referring to the “Table of Signals Supported” on page 43.

\* “IBM PC/AT” and “VGA” are registered trademarks of IBM, Inc. of the United States.

# OSD(On Screen Display) Controls

## Menu Operations

The OSD window is displayed with respect to the screen as shown on the diagram.

- Depending on the screen's mode, the OSD may be displayed differently.

In the explanation, the OSD section is shown close up.

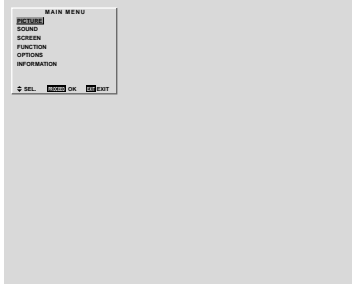

The following describes how to use the menus and the selected items.

- Press the PROCEED button on the remote controller to display the MAIN MENU.

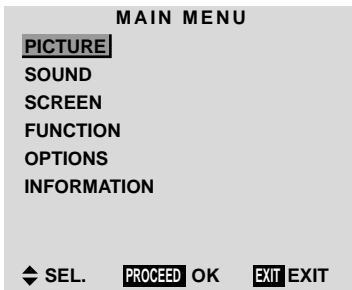

- Press the cursor buttons ▲ ▼ on the remote controller to highlight the menu you wish to enter.
- Press the PROCEED button on the remote controller to select a submenu or item.

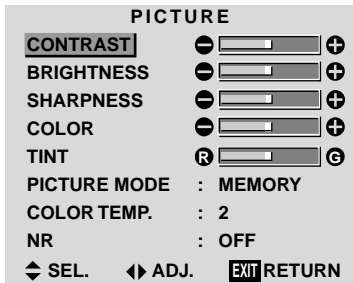

- Adjust the level or change the setting of the selected item by using the cursor buttons ◀ ▶ on the remote controller.

- The change is stored until you adjust it again.

- Repeat steps 2–5 to adjust an additional item, or press the EXIT button on the remote controller to return to the main menu.

**Note:** The main menu disappears by pressing the EXIT button.

Main menu	Sub menu	Functions	Default	Reset
PICTURE	CONTRAST	Adjusts the contrast.	Center	Yes
	BRIGHTNESS	Adjusts the brightness.	Center	Yes
	SHARPNESS	Adjusts the sharpness.	Center/1	Yes
	COLOR	Adjusts the color.	Center	Yes
	TINT	Adjusts the tint.	Center	Yes
	PICTURE MODE	Sets the picture mode according to the VIDEO environment and image software.	MEMORY	Yes
	COLOR TEMP NR	Adjusts the color temperature and white balance. Reduces noise visible in image.	2 OFF	Yes Yes

Main menu	Sub menu	Functions	Default	Reset
SOUND	BASS	Sets the bass.	Center	Yes
	TREBLE	Sets the treble.	Center	Yes
	BALANCE	Sets the left/right balance.	Center	Yes

Main menu	Sub menu	Functions	Default	Reset
SCREEN	V-POSITION	Adjusts the vertical position.	Center	Yes
	H-POSITION	Adjusts the horizontal position.	Center	Yes
	V-HEIGHT	Adjusts the vertical size.	Min	Yes
	H-WIDTH	Adjusts the horizontal size.	Min	Yes
	AUTO PICTURE	Turn this on to have the monitor automatically adjust "FINE PICTURE" and "PICTURE ADJ."	OFF*1	No
	FINE PICTURE PICTURE ADJ.	Adjusts for flickering on the computer image. Adjusts for striped patterns on the computer image.	Min*1 Center*1	Yes Yes

Main menu	Sub menu	Functions	Default	Reset
FUNCTION	OSD	Turns the on-screen display (screen mode, etc.) off (when set to "OFF"). When set to "ON," the on-screen display is displayed.	ON	Yes
	OSD ADJ.	Adjusts the vertical and horizontal positions of the menu display.	1	Yes
	POWER MGT	Sets the display for use as an energy-saving display when used with a computer.	OFF	Yes
	GRAY LEVEL	In 4:3 size, sets the luminance of both sides.	3	Yes
	CINEMA MODE	Sets the picture to suit the movie.	ON	Yes
	RGB3 ADJ.	Adjusts the picture when the picture input from the RGB3 input terminal is distorted.	1	Yes
	LONG LIFE	Sets the picture to reduce burn-in of the display.	*2	Yes
	RESET	Resets all the settings (PICTURE, SOUND, SCREEN, FUNCTION, etc.) to the factory default values.	—	—

Main menu	Sub menu	Functions	Default	Reset
OPTIONS	AUDIO INPUT	Sets the allocation of the audio connectors.	*3	Yes
	BNC SELECT	Sets the BNC connectors.	RGB	Yes
	RGB SELECT	Sets the appropriate mode for the computer image. RGB (VGA signals), VIDEO (Moving picture), WIDE (WIDE VGA) DTV.	AUTO	Yes
	HD SELECT	Sets the digital broadcasting (1080A,1080B) or the High Vision (10351).	1080B	No

Main menu	Sub menu	Functions	Default	Reset
INFORMATION	FREQUENCY	Used to check the frequency and synchronizing polarities of the signal currently being inputted.	—	—
	LANGUAGE	Sets the language of the menus (Chinese, English, German, French, Swedish, Italian or Spanish).	English	No
	COLOR SYSTEM	Sets the VIDEO format (AUTO1, AUTO2, PAL, PAL-M, PAL-N, PAL60, SECAM, 4.43 NTSC or 3.58 NTSC).	AUTO1	No

\*1 RGB/PC only.

\*2 PLE: AUTO; ORBITER: OFF; INVERSE: OFF; SCREEN WIPER: OFF.

\*3 AUDIO1: VIDEO1; AUDIO2: HD/DVD1; AUDIO3: RGB1.

## Picture Settings Menu

### Adjusting the picture

The contrast, brightness, sharpness, color and tint can be adjusted as desired.

Example: Adjusting the contrast

Press the **PROCEED** button on the remote controller to display the **MAIN MENU** on the screen, then...

1. Use the ▲ and ▼ buttons to select “**PICTURE**,” then press the **PROCEED** button. The “**PICTURE**” screen appears.
2. Use the ▲ and ▼ buttons to select “**CONTRAST**.”

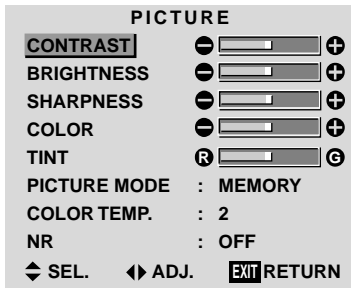

3. Use the ◀ and ▶ buttons to adjust the contrast.

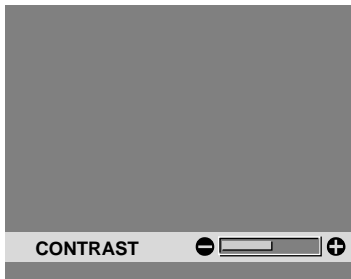

- If neither the ◀ or ▶ button is pressed within 5 seconds, the current setting is set and the previous screen reappears.

4. Once the adjustment is completed ...

Press the **EXIT** button to return to the main menu.

To close the main menu, press the **EXIT** button once more.

**Note:** If “**CAN NOT ADJUST**” appears ...  
When trying to enter the **PICTURE** submenu, make sure **PICTURE MODE** is set to **MEMORY**.

### Information

#### ■ Picture adjustment screen

**CONTRAST** .... Changes the picture’s contrast.

**BRIGHTNESS** .. Changes the picture’s brightness.

**SHARPNESS** .. Changes the picture’s sharpness.  
Adjusts picture detail of **VIDEO** display.

**COLOR** ..... Changes the color density.

**TINT** ..... Changes the picture’s tint. Adjust for natural colored skin, background, etc.

#### ■ Adjusting the computer image

Only the contrast and brightness can be adjusted when a computer signal is connected.

#### ■ Restoring the factory default settings

Select “**RESET**” under the “**PICTURE MODE**” settings.

## Setting the picture mode according to the brightness of the room

There are four picture modes that can be used effectively according to the environment in which you are viewing the display.

Example: Setting the "THEATER" mode

Press the **PROCEED** button on the remote controller to display the **MAIN MENU** on the screen, then...

1. Use the ▲ and ▼ buttons to select "PICTURE," then press the **PROCEED** button.

The "PICTURE" screen appears.

2. Use the ▲ and ▼ buttons to select "PICTURE MODE."

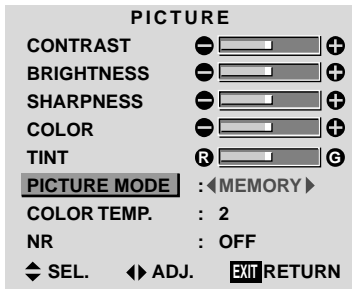

3. To set to "THEATER" ...

Use the ◀ and ▶ buttons to select "THEATER."

The mode switches as follows when the ◀ and ▶ buttons are pressed:

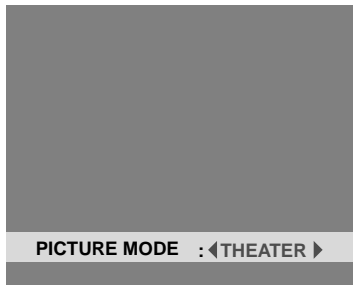
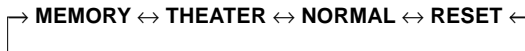

- If neither the ◀ or ▶ button is pressed within 5 seconds, the current selection is set and the previous screen reappears.

4. Once the adjustment is completed ...

Press the **EXIT** button to return to the main menu. To close the main menu, press the **EXIT** button once more.

### Information

#### ■ Types of picture modes

**MEMORY** ..... The last picture adjustments are stored here.

**THEATER** ..... Set this mode when watching video in a dark room.

This mode provides darker, finer pictures, like the screen in movie theaters.

CONTRAST = 80% for RESET mode.

BRIGHTNESS = 95% for RESET mode.

**NORMAL** ..... Set this mode when watching video in a bright room.

This mode provides dynamic pictures with distinct differences between light and dark sections.

CONTRAST = 96% for RESET mode.

**RESET** ..... Use this to reset the picture to the factory default settings.

## Setting the color temperature

Use this procedure to set color tone produced by the plasma display.

Example: Setting “1” (See chart at right)

Press the *PROCEED* button on the remote controller to display the *MAIN MENU* on the screen, then...

1. Use the ▲ and ▼ buttons to select “PICTURE,” then press the *PROCEED* button.  
The “PICTURE” screen appears.
2. Use the ▲ and ▼ buttons to select “COLOR TEMP.”

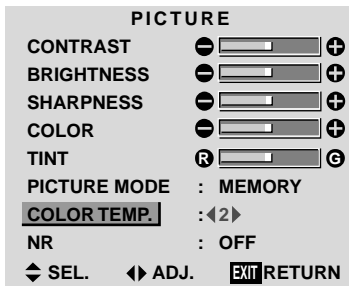

3. Use the ◀ and ▶ buttons to select “1.”  
The mode switches as follows when the ◀ and ▶ buttons are pressed:

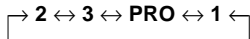

- See page 25 to set “PRO.”

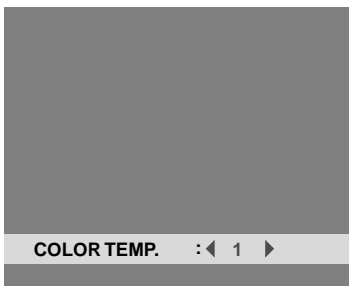

- If neither the ◀ or ▶ button is pressed within 5 seconds, the current selection is set and the previous screen reappears.

4. Once the setting is completed...

Press the *EXIT* button to return to the main menu.

To close the main menu, press the *EXIT* button once more.

### Information

#### ■ Setting the color temperature

- 1 ..... High (bluer)
- 2 ..... Middle (Standard)
- 3 ..... Low (redder)

#### ■ Restoring the factory default settings

Select “RESET” under the function menu. Note that this also restores other settings to the factory defaults.



## Adjusting the color to the desired quality

Use this procedure to adjust the white balance for bright pictures and dark pictures to achieve the desired color quality.

Example: Adjusting the “WHITE BALANCE”

Press the *PROCEED* button on the remote controller to display the *MAIN MENU* on the screen, then...

1. Use the ▲ and ▼ buttons to select “PICTURE,” then press the *PROCEED* button.  
The “PICTURE” screen appears.

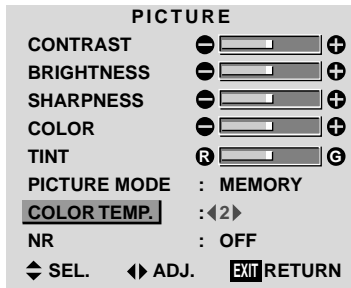

2. Use the ▲ and ▼ buttons to select “COLOR TEMP.”

3. Use the ◀ and ▶ buttons to select “PRO.”

The mode switches as follows when the ◀ and ▶ buttons are pressed:

→ 2 ↔ 3 ↔ PRO ↔ 1 ←

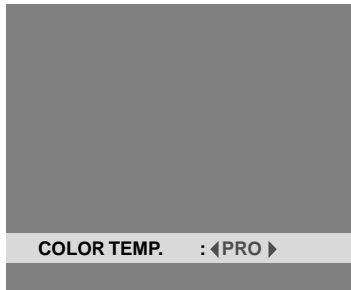

- If neither the ◀ or ▶ button is pressed within 5 seconds, the current selection is set and the previous screen reappears.

4. Press the *PROCEED* button.  
The “WHITE BALANCE” screen appears.
5. Use the ▲ and ▼ buttons to select “RED-GAIN.”

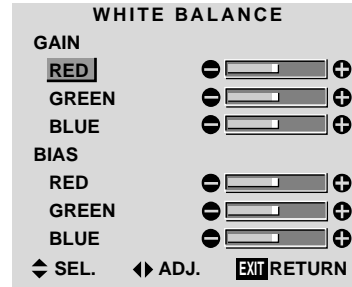

6. Adjust the white balance using the ◀ and ▶ buttons.

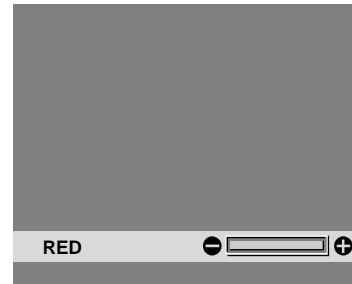

- If neither the ◀ or ▶ button is pressed within 5 seconds, the current setting is set and the previous screen reappears.

7. Once the adjustment is completed...

Press the *EXIT* button several times to return to the main menu. To close the main menu, press the *EXIT* button once more.

### Information

#### ■ Adjusting the white balance

RGB-GAIN ..... White balance adjustment for signal level

RGB-BIAS ..... White balance adjustment for black level

#### ■ Restoring the factory default settings

Select “RESET” under the function menu. Note that this also restores other settings to the factory defaults.

## Reducing noise in the picture

Use these settings if the picture has noise due to poor reception or when playing video tapes on which the picture quality is poor.

Example: Setting “NR-3”

Press the *PROCEED* button on the remote controller to display the *MAIN MENU* on the screen, then...

1. Use the ▲ and ▼ buttons to select “PICTURE,” then press the *PROCEED* button.  
The “PICTURE” screen appears.
2. Use the ▲ and ▼ buttons to select “NR.”

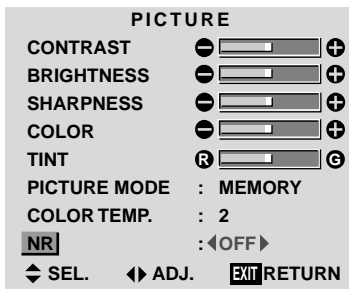

3. Use the ◀ and ▶ buttons to select “NR-3.”  
The mode switches as follows when the ◀ and ▶ buttons are pressed:

→ OFF ↔ NR-1 ↔ NR-2 ↔ NR-3 ←

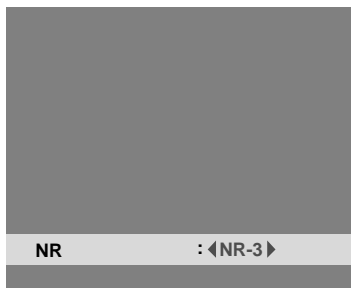

- If neither the ◀ or ▶ button is pressed within 5 seconds, the current selection is set and the previous screen reappears.

4. *Once the setting is completed ...*

Press the *EXIT* button to return to the main menu.

To close the main menu, press the *EXIT* button once more.

### Information

#### ■ NR

- “NR” stands for Noise Reduction.
- This function reduces noise in the picture.

#### ■ Types of noise reduction

There are three types of noise reduction. Each has a different level of noise reduction.

The effect becomes stronger as the number increases (in the order NR-1 → NR-2 → NR-3).

OFF ..... Turns the noise reduction function off.

## Sound Settings Menu

### Adjusting the treble, bass and left/right balance

The treble, bass and left/right balance can be adjusted to suit your tastes.

Example: Adjusting the bass

Press the **PROCEED** button on the remote controller to display the **MAIN MENU** on the screen, then...

1. Use the ▲ and ▼ buttons to select “**SOUND**,” then press the **PROCEED** button.  
The “**SOUND**” screen appears.
2. *To adjust the bass ...*  
Use the ▲ and ▼ buttons to select “**BASS**.”

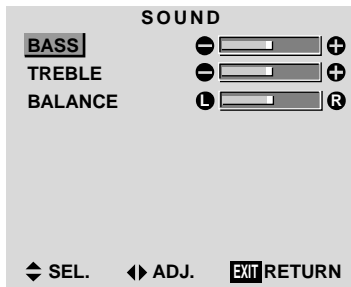

3. Adjust the bass using the ◀ and ▶ buttons.

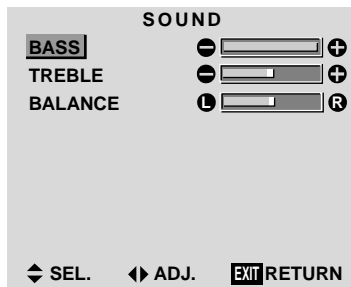

- If neither the ◀ or ▶ button is pressed within 5 seconds, the current selection is set and the previous screen reappears.

To continue adjusting the sound ...  
Repeat from step 2.

4. *Once the adjustment is completed ...*  
Press the **EXIT** button to return to the main menu. To close the main menu, press the **EXIT** button once more.

**Note :** If “**CAN NOT ADJUST**” appears...  
Set “**AUDIO INPUT**” on the **OPTIONS** menu correctly.

### Information

#### ■ Sound settings menu

**BASS** ..... Changes the level of low frequency sound.  
**TREBLE** ..... Changes the level of high frequency sound.  
**BALANCE** ..... Changes the balance of the left and right channels.

#### ■ Restoring the factory default settings

Select “**RESET**” under the function menu. Note that this also restores other settings to the factory defaults.

## Screen Settings Menu

### Adjusting the Position, Size, Fine Picture, Picture Adj

The position of the image can be adjusted and flickering of the image can be corrected.

Example: Adjusting the vertical position in the normal mode

Press the **PROCEED** button on the remote controller to display the **MAIN MENU** on the screen, then...

1. Use the ▲ and ▼ buttons to select “SCREEN,” then press the **PROCEED** button. The “SCREEN” menu appears.

Default settings (when RGB/PC is selected)

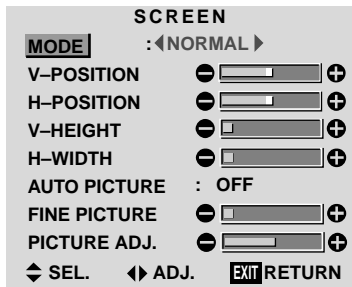

- The settings on the SCREEN menu are not preset at the factory.

To select a mode ...

Use the ◀ and ▶ buttons to select a mode.

The mode switches as follows when the ◀ and ▶ buttons are pressed:



- The mode can also be switched by pressing the “WIDE” button on the remote controller.

2. To adjust the vertical position ...

Use the ▲ and ▼ buttons to select “V-POSITION”.

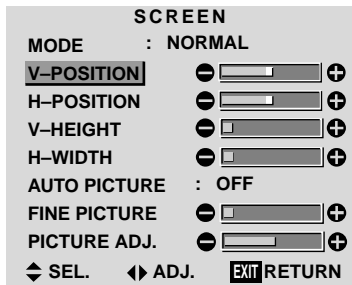

3. Adjust using the ◀ and ▶ buttons.

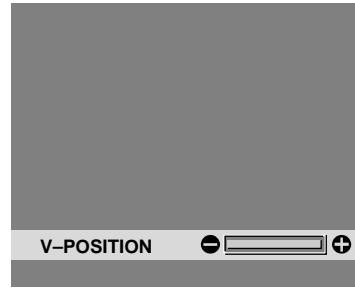

- If neither the ◀ or ▶ button is pressed within 5 seconds, the current setting is set and the previous screen reappears.

To continue making other computer image adjustments ...

Repeat from step 2.

4. Once all adjustments are completed ...

Press the **EXIT** button to return to the main menu.

To close the main menu, press the **EXIT** button once more.

### Information

#### ■ When “AUTO PICTURE” is “OFF”

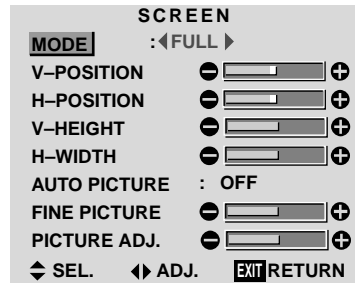

When Auto Picture is off, the Fine Picture and the Picture ADJ items are displayed so that you can adjust them.

## Information

### ■ Adjusting the Auto Picture

- ON ..... The Picture ADJ and Fine Picture adjustments are made automatically.
- OFF ..... The Picture ADJ and Fine Picture adjustments are made manually.

### ■ Adjusting the position of the image

- V-POSITION ... Adjusts the vertical position of the image.
- H-POSITION ... Adjusts the horizontal position of the image.
- V-HEIGHT ..... Adjusts the vertical size of the image. (Except for JUST mode)
- H-WIDTH ..... Adjusts the horizontal size of the image. (Except for JUST mode)
- FINE PICTURE\* .. Adjusts for flickering.
- PICTURE ADJ\* ... Adjusts for striped patterns on the image.

\* The Picture ADJ and Fine Picture features are available only when the "Auto Picture" is off. The Auto Picture, Fine Picture and Picture ADJ features are available only for RGB signals.

### ■ Restoring the factory default settings

Select "RESET" under the function menu. Note that this also restores other settings to the factory defaults except for Auto Picture.

## Function Settings Menu

### Setting the on-screen display

When using the display for presentations, etc., the display can be set so that the input source, screen mode, etc., do not appear.

Example: Turning the on-screen display mode off

Press the *PROCEED* button on the remote controller to display the *MAIN MENU* on the screen, then...

1. Use the ▲ and ▼ buttons to select "FUNCTION," then press the *PROCEED* button.  
The "FUNCTION" screen appears.
2. Use the ▲ and ▼ buttons to select "OSD."

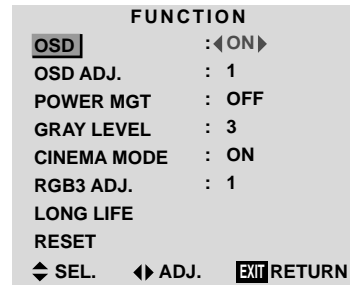

3. To turn the on-screen display mode off ...  
Use the ◀ and ▶ buttons to select "OFF."  
The mode switches as follows each time the ◀ or ▶ button is pressed:

ON ↔ OFF

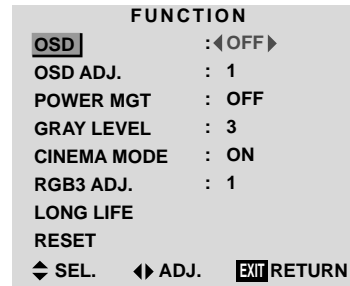

4. Once the setting is completed ...  
Press the *EXIT* button to return to the main menu.  
To close the main menu, press the *EXIT* button once more.

## Information

### ■ OSD modes

- ON ..... The on-screen display appears.
- OFF ..... The on-screen display does not appear.

### ■ Restoring the factory default settings

Select "RESET" under the function menu. Note that this also restores other settings to the factory defaults.

## Adjusting the position of the menu display

Use these operations to adjust the position of the menus that appear on the screen.

Example: Adjusting the position of the menu display

Press the **PROCEED** button on the remote controller to display the **MAIN MENU** on the screen, then...

1. Use the ▲ and ▼ buttons to select “FUNCTION,” then press the **PROCEED** button. The “FUNCTION” menu appears.
2. Use the ▲ and ▼ buttons to select “OSD ADJ.”

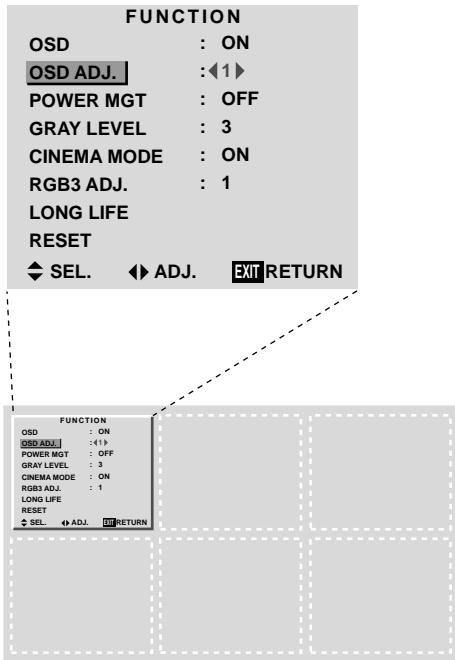

3. To adjust the position...

Adjust using the ◀ and ▶ buttons.

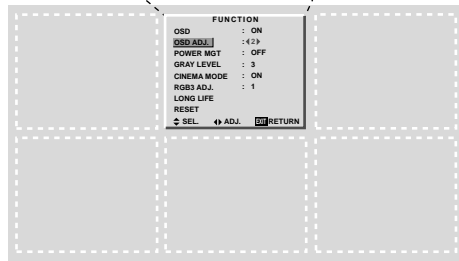
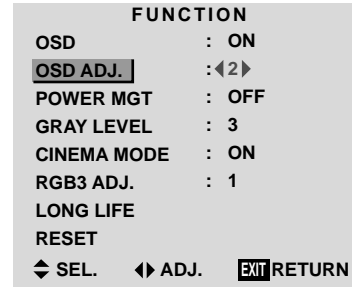

4. Once all adjustments are completed ...

Press the **EXIT** button to return to the main menu.

To close the main menu, press the **EXIT** button once more.

### Information

#### ■ Adjusting the position of the menu display

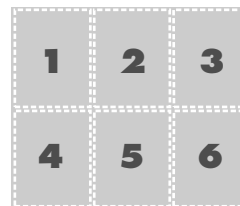

The position can be set between 1 and 6.

#### ■ Restoring the factory default settings

Select “RESET” under the function menu. Note that this also restores other settings to the factory defaults.

## Setting the power management for computer images

This energy-saving (power management) function automatically reduces the monitor's power consumption if no operation is performed for a certain amount of time.

Example: Turning the power management function on

Press the *PROCEED* button on the remote controller to display the *MAIN MENU* on the screen, then...

1. Use the ▲ and ▼ buttons to select "FUNCTION," then press the *PROCEED* button.  
The "FUNCTION" screen appears.
2. Use the ▲ and ▼ buttons to select "POWER MGT."

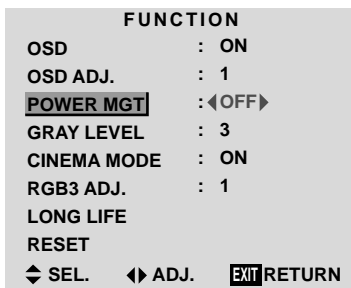

3. To turn the power management function on ...  
Use the ◀ and ▶ buttons to select "ON."  
The mode switches as follows each time the ◀ or ▶ button is pressed:  
**ON ↔ OFF**

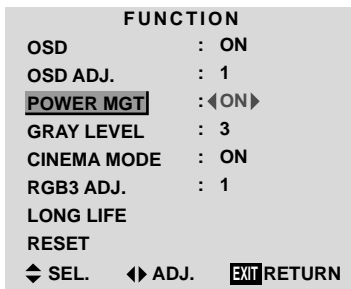

4. Once the setting is completed ...  
Press the *EXIT* button to return to the main menu.  
To close the main menu, press the *EXIT* button once more.

## Information

### ■ Power management function

- The power management function automatically reduces the display's power consumption if the computer's keyboard or mouse is not operated for a certain amount of time. This function can be used when using the display with a computer conforming to the VESA DPMS format.
- If the computer's power is not turned on or if the computer and selector tuner are not properly connected, the system is set to the off state.
- For instructions on using the computer's power management function, refer to the computer's operating instructions.

### ■ Power management settings

ON ..... In this mode the power management function is turned on.

OFF ..... In this mode the power management function is turned off.

### ■ Power management function and POWER/STANDBY indicator

The POWER/STANDBY indicator indicates the status of the power management function. See page 32 for indicator status and description.

### ■ Restoring the factory default settings

Select "RESET" under the function menu. Note that this also restores other settings to the factory defaults.

---

**POWER/STANDBY indicator**

Power management mode	POWER/STANDBY indicator	Power management operating status	Description	Turning the picture back on
On	Green	Not activated.	Horizontal and vertical synchronizing signals are present from the computer.	Picture already on.
Standby	Orange	Activated.	No horizontal synchronizing signals are sent from the computer.	Operate the keyboard or mouse. The picture reappears immediately.
Suspend	Red	Activated.	No vertical synchronizing signals are sent from the computer.	Operate the keyboard or mouse. The picture reappears, but more time is required than from the standby mode.
Off	Red	Activated.	No horizontal and vertical synchronizing signals are sent from the computer.	Operate the keyboard or mouse. The picture reappears, but more time is required than from the standby mode or suspend mode.



## Setting the gray level for the sides of the screen

Use this procedure to set the gray level for the parts on the screen on which nothing is displayed when the screen is set to the 4:3 size.

Example: Adjusting the “GRAY LEVEL”

Press the **PROCEED** button on the remote controller to display the **MAIN MENU** on the screen, then...

1. Use the ▲ and ▼ buttons to select “FUNCTION,” then press the **PROCEED** button.  
The “FUNCTION” screen appears.
2. Use the ▲ and ▼ buttons to select “GRAY LEVEL.”

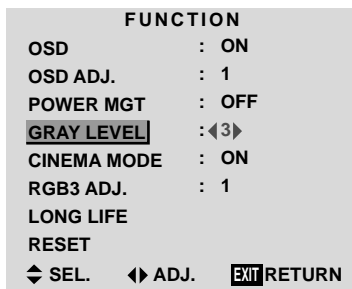

3. To adjust the “GRAY LEVEL”...  
Use the ◀ and ▶ buttons to adjust the GRAY LEVEL.

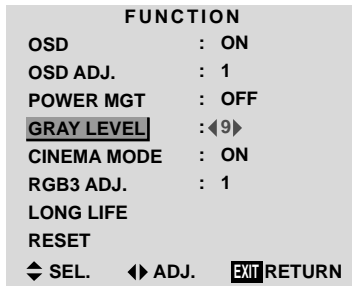

4. Once the setting is completed ...  
Press the **EXIT** button to return to the main menu.  
To close the main menu, press the **EXIT** button once more.

### Information

#### ■ GRAY LEVEL

This adjusts the brightness of the black (the gray level) for the sides of the screen.  
The standard is 0 (black). The level can be adjusted from 0 to 15. The factory setting is 3 (dark gray).

#### ■ Restoring the factory default settings

Select “RESET” under the function menu. Note that this also restores other settings to the factory defaults.

## Setting the picture to suit the movie

The film image is automatically detected and projected in an image mode suited to the picture.

[NTSC, PAL, PAL60, 480I (60Hz), 525I (60Hz), 576I (50Hz), 625I (50Hz), 1035I (60Hz), 1080I (60Hz) only]

Example: Setting the “CINEMA MODE” to “OFF”

Press the **PROCEED** button on the remote controller to display the **MAIN MENU** on the screen, then...

1. Use the ▲ and ▼ buttons to select “FUNCTION,” then press the **PROCEED** button.  
The “FUNCTION” screen appears.
2. Use the ▲ and ▼ buttons to select “CINEMA MODE.”

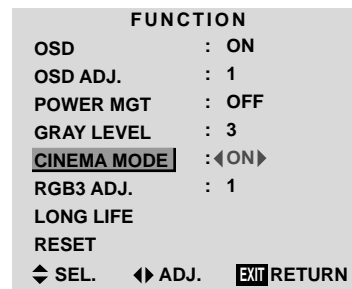

3. To set the **CINEMA MODE** to “OFF” ...  
Use the ◀ and ▶ buttons to select “OFF.”  
The mode switches as follows each time the ◀ or ▶ button is pressed:

→ ON ↔ OFF ←

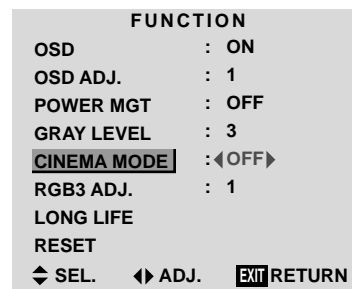

4. Once the setting is completed ...  
Press the **EXIT** button to return to the main menu.  
To close the main menu, press the **EXIT** button once more.

### Information

#### ■ CINEMA MODE

ON ..... Automatic detection of the image and projection in cinema mode.  
OFF ..... Cinema mode does not function.

#### ■ Restoring the factory default settings

Select “RESET” under the function menu. Note that this also restores other settings to the factory defaults.

## Setting RGB3 ADJ.

When the picture input from the RGB3 input terminal is distorted, select the most appropriate setting from among “1,” “2,” and “3.”

Example: Setting “2”

Press the **PROCEED** button on the remote controller to display **MAIN MENU** on the screen, then...

1. Use the ▲ and ▼ buttons to select “FUNCTION,” then press the **PROCEED** button.  
The “FUNCTION” screen appears.
2. Use the ▲ and ▼ buttons to select “RGB3 ADJ.”

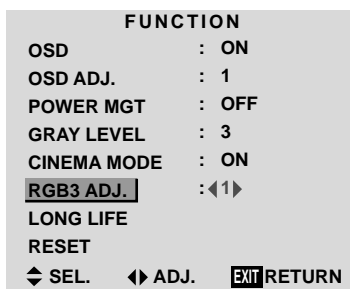

3. To select “2”...

Use the ◀ and ▶ buttons to select “2.”  
The mode switches as follows each time the ◀ or ▶ button is pressed:

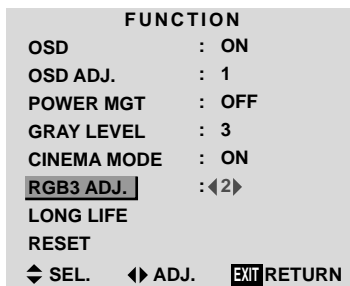
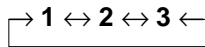

4. Once the setting is completed...

Press the **EXIT** button to return to the main menu.  
To close the main menu, press the **EXIT** button once more.

### Information

#### ■ When you adjust the RGB3 ADJ.

The position of the menu display will change. In such a case, be sure to adjust the position.

#### ■ Restoring the factory default settings

Select “RESET” under the function menu. Note that this also restores other settings to the factory defaults.

## Reducing burn-in of the screen

The brightness of the screen, the position of the picture, positive/negative mode and screen wiper are adjusted to reduce burn-in of the screen.

Example: Setting “PLE” to “LOCK”

Press the **PROCEED** button on the remote controller to display the **MAIN MENU** on the screen, then proceed as follows.

1. Use the ▲ and ▼ buttons to select “FUNCTION,” then press the **PROCEED** button.  
The “FUNCTION” screen appears.
2. Use the ▲ and ▼ buttons to select “LONG LIFE,” then press the **PROCEED** button.

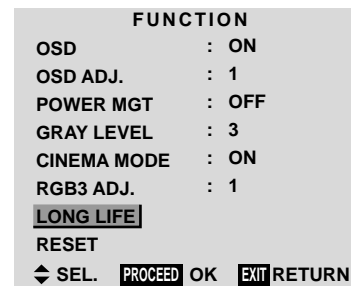

The “LONG LIFE” screen appears.

3. Use the ▲ and ▼ buttons to select “PLE.”

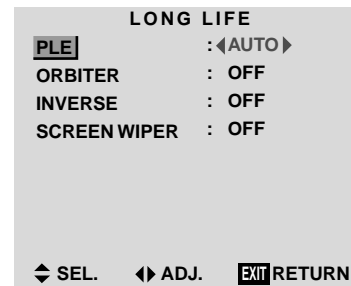

4. Use the ◀ and ▶ buttons to select “LOCK.”  
The mode switches as follows each time the ◀ or ▶ button is pressed:

AUTO ↔ LOCK

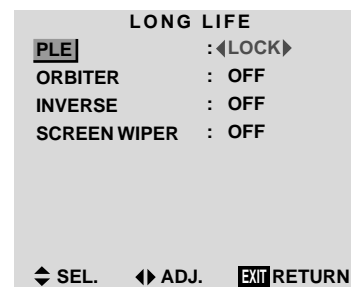

5. *Once the setting is completed...*

Press the EXIT button to return to the FUNCTION menu.

To close the main menu, press the EXIT button twice.

**Information**

■ **PLE**

AUTO ..... The brightness of the screen is adjusted automatically to suit the picture quality.

LOCK ..... The brightness level is set to minimum.

■ **ORBITER**

OFF ..... Orbiter mode does not function.

ON ..... The picture moves around the screen intermittently.

■ **INVERSE**

OFF ..... Inverse mode does not function.

ON ..... The picture is displayed alternately between positive image and negative image.

You can set the time by pressing the PROCEED button while “ON” is set.

WT ..... The entire screen turns white.

You can set the time by pressing the PROCEED button while “ON” is set.

■ **SCREEN WIPER**

OFF ..... Screen wiper mode does not function.

ON ..... Repeatedly moves the white vertical bar from the left end of the screen to the right end at a constant speed.

You can set the time by pressing the PROCEED button while “ON” is set.

■ **Restoring the factory default settings**

Select “RESET” from the function menu. Note that this also restores other settings to the factory defaults.

- Only the PLE and ORBITER can be adjusted when an RGB signal is connected.

**Setting the time for “INVERSE”**

Set the “INVERSE” or “WHITE” display time and the “WAITING TIME.”

Example: Setting so that the INVERSE mode starts in 30 minutes and proceeds for one and a half hours.

*Perform Steps 1-2 on Page 34, then...*

3. Use the ▲ and ▼ buttons to select “INVERSE,” then use the ◀ and ▶ buttons to select “ON.”

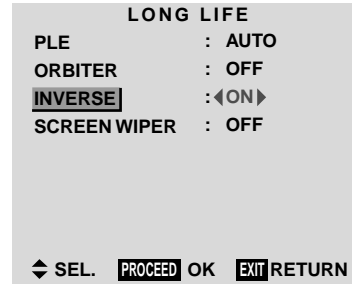

4. Press the PROCEED button.  
The “INVERSE/WT” screen appears.

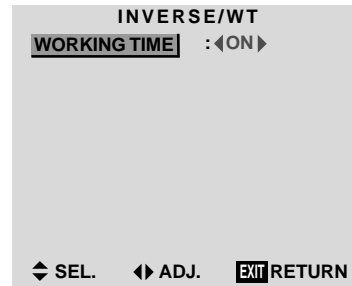

5. Adjust the time using the ◀ and ▶ buttons and the ▲ and ▼ buttons.  
The mode switches as follows each time the ◀ or ▶ button is pressed.

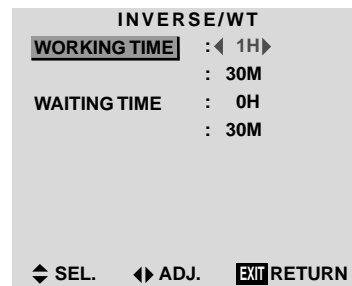

The 1st line of the “WORKING TIME”:

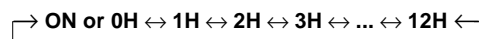

- The “WORKING TIME” (minutes) and “WAITING TIME” cannot be set when the “WORKING TIME” is “ON.”

The 2nd line of the “WORKING TIME”:

→ 0M ↔ 3M ↔ 6M ↔ 9M ↔ ... ↔ 57M ←

The 1st line of the “WAITING TIME”:

→ 0H ↔ 1H ↔ 2H ↔ 3H ↔ ... ↔ 12H ←

The 2nd line of the “WAITING TIME”:

→ 0M ↔ 3M ↔ 6M ↔ 9M ↔ ... ↔ 57M ←

6. *Once the setting is completed...*

Press the EXIT button several times to return to the main menu.

To close the main menu, press the EXIT button once more.

**Information**

■ **Setting the time**

**WORKING TIME**

Set the length of time the “INVERSE/WT” mode lasts. When the WORKING TIME is set to “ON,” the “INVERSE/WT” mode stays in the on state.

**WAITING TIME**

Set the length of time until the “INVERSE/WT” mode starts.

- The “WORKING TIME” and “WAITING TIME” can be set for up to 12 hours and 45 minutes in units of 3 minutes.

■ **To select “ON” for the “WORKING TIME”...**

Set the hours of the WORKING TIME to 0H and the minutes to 0M. “ON” will be displayed.

**Setting the time for “SCREEN WIPER”**

Set the “SCREEN WIPER” operation time, “WAITING TIME,” and “SPEED.”

Example: Setting so that the SCREEN WIPER mode starts in 30 minutes and proceeds for one and a half hours.

*Perform Steps 1-2 on Page 34, then...*

3. Use the ▲ and ▼ buttons to select “SCREEN WIPER,” then use the ◀ and ▶ buttons to select “ON.”

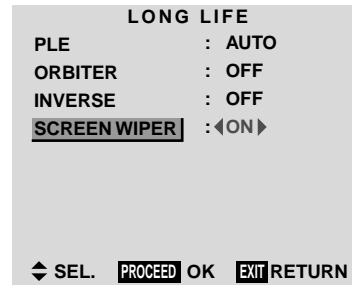

4. Press the PROCEED button. The “SCREEN WIPER” screen appears.

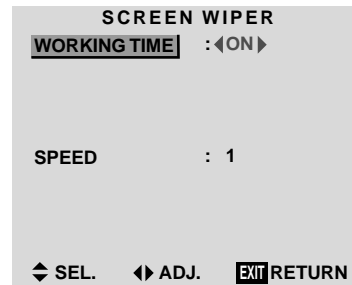

5. Adjust the time and speed using the ◀ and ▶ buttons and the ▲ and ▼ buttons. The mode switches as follows each time the ◀ and ▶ button is pressed.

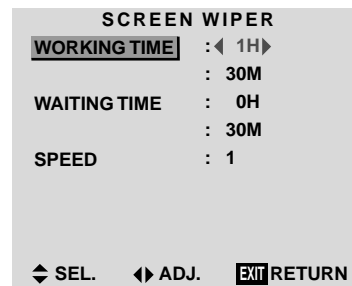

The 1st line of the “WORKING TIME”:

→ ON or 0H ↔ 1H ↔ 2H ↔ 3H ↔ ... ↔ 12H ←

- The “WORKING TIME” (minutes) and “WAITING TIME” cannot be set when the “WORKING TIME” is “ON.”

The 2nd line of the “WORKING TIME”:

→ 0M ↔ 3M ↔ 6M ↔ 9M ↔ ... ↔ 57M←

The 1st line of the “WAITING TIME”:

→ 0H ↔ 1H ↔ 2H ↔ 3H ↔ ... ↔ 12H←

The 2nd line of the “WAITING TIME”:

→ 0M ↔ 3M ↔ 6M ↔ 9M ↔ ... ↔ 57M←

“SPEED”:

→ 1 ↔ 2 ↔ 3 ↔ 4 ↔ 5←

6. *Once the setting is completed...*

Press the EXIT button several times to return to the main menu.

To close the main menu, press the EXIT button once more.

### Information

#### ■ Setting the time

##### WORKING TIME

Set the length of time the “SCREEN WIPER” mode lasts.

When the WORKING TIME is set to “ON,” the “SCREEN WIPER” mode stays in the last mode.

##### WAITING TIME

Set the length of time until the “SCREEN WIPER” mode starts.

##### SPEED

Set the moving speed for the “SCREEN WIPER”. The speed decreases as the number increases.

- The “WORKING TIME” and “WAITING TIME” can be set for up to 12 hours and 45 minutes in units of 3 minutes.

#### ■ To select “ON” for “WORKING TIME”...

Set the hours of the “WORKING TIME” to 0H and the minutes to 0M. “ON” will be displayed.

## Resetting to the default values

Use these operations to restore all the picture adjustments, audio settings, to the factory default values.

Refer to page 21 for items to be reset.

*Press the PROCEED button on the remote controller to display the MAIN MENU on the screen, then...*

1. Use the ▲ and ▼ buttons to select “FUNCTION,” then press the PROCEED button.  
The “FUNCTION” screen appears.
2. Use the ▲ and ▼ buttons to select “RESET,” then press the PROCEED button.

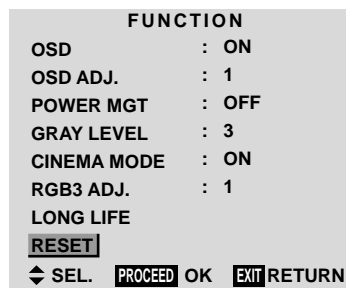

The “RESET” screen appears.

3. Use the ▲ and ▼ buttons to select “RESET,” then press the PROCEED button.



When the “SETTING NOW” screen disappears, the screen will be restored to the previous “RESET” mode, then all the settings are restored to the default values.

4. *Once the setting is completed ...*

Press the EXIT button.

To close the main menu, press the EXIT button once more.

## Options Settings Menu

### Setting the allocation of the audio connectors

Setting the AUDIO 1, 2, and 3 connectors to the desired input.

Example: Setting "AUDIO 1" to "VIDEO 2"

Press the *PROCEED* button on the remote controller to display the *MAIN MENU* on the screen, then...

1. Use the ▲ and ▼ buttons to select "OPTIONS," then press the *PROCEED* button.  
The "OPTIONS" screen appears.
2. Use the ▲ and ▼ buttons to select "AUDIO1."



3. To set the *AUDIO1* to "VIDEO2"...

Use the ◀ and ▶ buttons to select "VIDEO2."

The mode switches as follows each time the ◀ or ▶ button is pressed.

The available sources depend on the setting of "BNC SELECT".

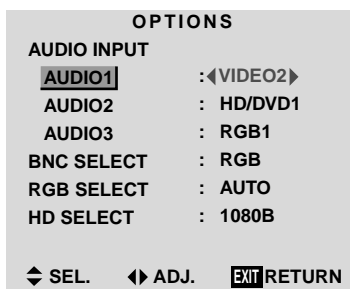
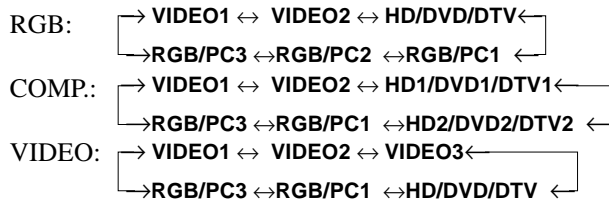

4. Once the setting is completed...

Press the *EXIT* button to return to the main menu.

To close the main menu, press the *EXIT* button once more.

### Information

#### ■ AUDIO INPUT

A single audio input cannot be selected as the audio channel for more than one input terminal.

#### ■ Restoring the factory default settings

Select "RESET" under the function menu. Note that this also restores other settings to the factory defaults.

## Setting the BNC connectors

Select whether to set the input of the 5 BNC connectors to RGB, component or video.

Example: Set the BNC SELECT mode to "COMP."

Press the **PROCEED** button on the remote controller to display the **MAIN MENU** on the screen, then...

1. Use the ▲ and ▼ buttons to select "OPTIONS," then press the **PROCEED** button.  
The "OPTIONS" screen appears.
2. Use the ▲ and ▼ buttons to select "BNC SELECT."

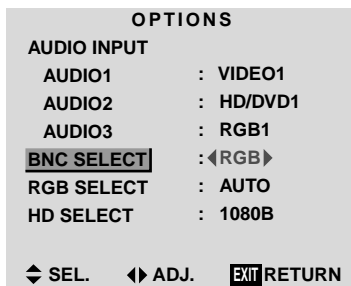

3. To set the BNC SELECT mode to "COMP."...  
Use the ◀ and ▶ buttons to select "COMP."  
The mode switches as follows each time the ◀ or ▶ button is pressed:

→ RGB ↔ COMP. ↔ VIDEO ←



4. Once the setting is completed...  
Press the **EXIT** button to return to the main menu.  
To close the main menu, press the **EXIT** button once more.

### Information

#### ■ BNC SELECT

- RGB ..... Use the 5BNC terminal for RGB input.
- COMP. .... Use the 3BNC terminal for component input.
- VIDEO ..... Use the G/Y/VIDEO 3 terminal for video input.

#### ■ Restoring the factory default settings

Select "RESET" under the function menu. Note that this also restores other settings to the factory defaults.

## Setting a computer image to the correct RGB select screen

With the computer image, select the RGB Select mode for a moving image such as (video) mode, wide mode or digital broadcast.

Example: Setting the "RGB SELECT" mode to "MOTION "

Press the **PROCEED** button on the remote controller to display the **MAIN MENU** on the screen, then...

1. Use the ▲ and ▼ buttons to select "OPTIONS," then press the **PROCEED** button.  
The "OPTIONS" screen appears.
2. Use the ▲ and ▼ buttons to select "RGB SELECT."



3. To set the RGB select mode to "MOTION" ...  
Use the ◀ and ▶ buttons to select "MOTION."  
The mode switches as follows each time the ◀ or ▶ button is pressed:

→ AUTO ↔ STILL ↔ MOTION ↔ WIDE1 ↔ WIDE2 ↔ DTV ←



4. Once the setting is completed ...  
Press the **EXIT** button to return to the main menu.  
To close the main menu, press the **EXIT** button once more.

## Information

### ■ RGB SELECT modes

One of these 6 modes must be selected in order to display the following signals correctly.

**AUTO** ..... Automatically selects the suitable mode for the specifications of input signals as listed in the table “Computer input signals supported by this system” on page 43.

**STILL** ..... To display VESA standard signals. (Use this mode for a still image from a computer.)

**MOTION**..... The video signal (from a scan converter) will be converted to RGB signals to make the picture more easily viewable. (Use this mode for a motion image from a computer.)

**WIDE1** ..... When an 852 dot × 480 line signal with a horizontal frequency of 31.7kHz is input, the image may be compressed horizontally. To prevent this, set RGB SELECT to WIDE1.

**WIDE2** ..... When an 848 dot × 480 line signal with a horizontal frequency of 31.0 kHz is input, the image may be compressed horizontally. To prevent this, set RGB SELECT to WIDE2.

**DTV** ..... Set this mode when watching digital broadcasting (480P).

See page 43 for the details of the above settings.

### ■ Restoring the factory default settings

Select “RESET” under the function menu. Note that this also restores other settings to the factory defaults.

## Setting high definition images to the suitable screen size

Use this procedure to set the number of vertical lines of the input high definition image to 1035 or 1080.

Example: Setting the “1080B” mode to “1035I”

Press the **PROCEED** button on the remote controller to display the **MAIN MENU** on the screen, then...

1. Use the ▲ and ▼ buttons to select “**OPTIONS**,” then press the **PROCEED** button.  
The “**OPTIONS**” screen appears.

2. Use the ▲ and ▼ buttons to select “**HD SELECT**.”



3. To set the **HD SELECT** mode to “1035I” ...

Use the ◀ and ▶ buttons to select “1035I.”

The mode switches as follows each time the ◀ or ▶ button is pressed:

→1080B ↔ 1035I ↔ 1080A ←



4. Once the setting is completed ...

Press the **EXIT** button to return to the main menu.

To close the main menu, press the **EXIT** button once more.

## Information

### ■ HD SELECT modes

These 3 modes are not displayed in correct image automatically.

**1080B** ..... Standard digital broadcasts

**1035I** ..... Japanese “High Vision” signal format

**1080A** ..... Special Digital broadcasts



## Information Menu

### Checking the frequencies, polarities of input signals, and resolution

Use this function to check the frequencies and polarities of the signals currently being input from a computer, etc.

Press the **PROCEED** button on the remote controller to display the **MAIN MENU** on the screen, then...

1. Use the ▲ and ▼ buttons to select “**INFORMATION**,” then press the **PROCEED** button.  
The “**INFORMATION**” screen appears.
2. Use the ▲ and ▼ buttons to select “**FREQUENCY**,” then press the **PROCEED** button.

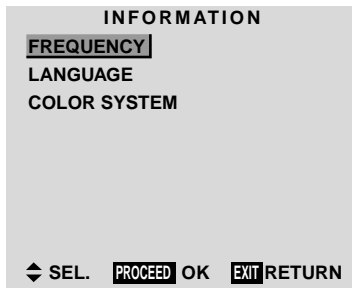

3. The frequency is displayed.

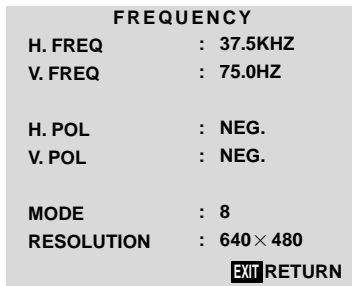

- Press the **EXIT** button to return to the previous screen.

4. *Once you have checked the frequency ...*  
Press the **EXIT** button to return to the main menu.  
To close the main menu, press the **EXIT** button once more.

### Setting the language for the menus

The menu display can be set to one of seven languages: Chinese, English, German, French, Swedish, Italian or Spanish.

Example: Setting the menu display to “**DEUTSCH**”

Press the **PROCEED** button on the remote controller to display the **MAIN MENU** on the screen, then...

1. Use the ▲ and ▼ buttons to select “**INFORMATION**,” then press the **PROCEED** button.  
The “**INFORMATION**” screen appears.
2. Use the ▲ and ▼ buttons to select “**LANGUAGE**,” then press the **PROCEED** button.

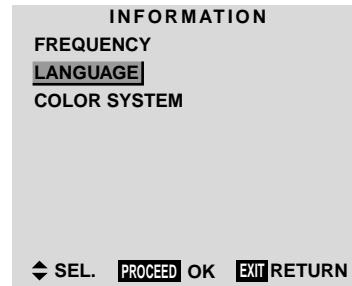

The “**LANGUAGE**” screen appears.

3. *To select “**DEUTSCH**” ...*  
Use the ◀ and ▶ buttons to select “**DEUTSCH**.”  
The mode switches as follows when the ◀ and ▶ buttons are pressed:



4. Press the **PROCEED** button.  
The display language is switched to **Deutsch**.
5. *Once the setting is completed ...*  
Press the **EXIT** button to return to the main menu.  
To close the main menu, press the **EXIT** button once more.

### Information

#### ■ Language settings

ENGLISH .....	English	ITALIANO .....	Italian
DEUTSCH .....	German	SVENSKA .....	Swedish
FRANÇAIS .....	French	中文 .....	Chinese
ESPAÑOL .....	Spanish		

## Setting the video signal format

Use these operations to set the video signal format.

Example: Setting the video signal format to “3.58 NTSC”

Press the *PROCEED* button on the remote controller to display the *MAIN MENU* on the screen, then...

1. Use the ▲ and ▼ buttons to select “*INFORMATION*,” then press the *PROCEED* button. The “*INFORMATION*” screen appears.
2. Use the ▲ and ▼ buttons to select “*COLOR SYSTEM*,” then press the *PROCEED* button.

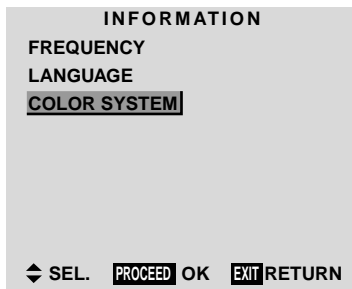

The “*COLOR SYSTEM*” screen appears.

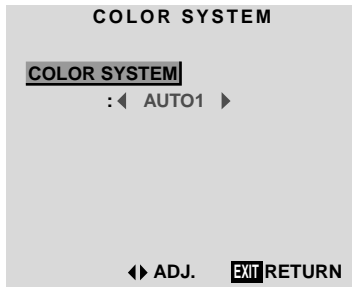

3. To select “3.58 NTSC” ...

Use the ◀ and ▶ buttons to select “3.58 NTSC.” The mode switches as follows when the ◀ and ▶ buttons are pressed:

→ AUTO1 ↔ AUTO2 ↔ 3.58NTSC ↔ 4.43NTSC ←  
→ SECAM ↔ PAL-M ↔ PAL-N ↔ PAL60 ↔ PAL ←

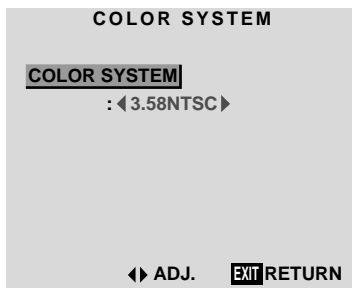

4. Once the setting is completed ...

Press the *EXIT* button to return to the main menu. To close the main menu, press the *EXIT* button once more.

The color system is set to “3.58 NTSC.”

### Information

#### ■ Video signal formats

Different countries use different formats for video signals. Set to the format used in your country.

**AUTO1/2** ..... The video signals are automatically detected and the format is set accordingly.

**AUTO1:** 3.58NTSC, 4.43NTSC, PAL, SECAM, PAL60

**AUTO2:** PAL-M, PAL-N, 3.58NTSC

**PAL (B, G)** ..... This is the standard format used mainly in the United Kingdom and Germany.

**SECAM**..... This is the standard format used mainly in France and Russia.

**4.43 NTSC,**

**PAL60** ..... This format is used for videos in countries using PAL and SECAM video signals.

**3.58 NTSC** ..... This is the standard format used mainly in Japan and the United States.

**PAL-M** ..... This is the standard format used mainly in Brazil.

**PAL-N** ..... This is the standard format used mainly in Argentina.

# Table of Signals Supported

## Supported resolution

- When the screen mode is NORMAL, each signal is converted to a 768 dots × 768 lines signal. (Except for \*2.\*4)
- When the screen mode is FULL, each signal is converted to a 1024 dots × 768 lines signal. (Except for \*3)

## Computer input signals supported by this system

Model Signal Type	Dots × lines	Vertical frequency (Hz)	Horizontal frequency (kHz)	Sync Polarity		Presence		Screen mode		RGB select*5	DVI
				Horizontal	Vertical	Horizontal	Vertical	NORMAL (4:3)	FULL (16:9)		
*IBM PC/AT compatible computers	640 × 400	70.1	31.5	NEG	NEG	YES	YES	YES*2*3	YES	--	NO
	640 × 480	59.9	31.5	NEG	NEG	YES	YES	YES*3	YES	STILL	YES
		72.8	37.9	NEG	NEG	YES	YES	YES*3	YES	--	YES
		75.0	37.5	NEG	NEG	YES	YES	YES*3	YES	STILL	YES
		85.0	43.3	NEG	NEG	YES	YES	YES*3	YES	--	YES
		100.4	51.1	NEG	NEG	YES	YES	YES*3	YES	--	YES
		120.4	61.3	NEG	NEG	YES	YES	YES*3	YES	--	YES
	848 × 480	60.0	31.0	POS	POS	YES	YES	--	YES	WIDE2	YES
	852 × 480*1	60.0	31.7	NEG	NEG	YES	YES	--	YES	WIDE1	YES
	800 × 600	56.3	35.2	POS	POS	YES	YES	YES	YES	STILL	YES
		60.3	37.9	POS	POS	YES	YES	YES	YES	STILL	YES
		72.2	48.1	POS	POS	YES	YES	YES	YES	--	YES
		75.0	46.9	POS	POS	YES	YES	YES	YES	--	YES
		85.1	53.7	POS	POS	YES	YES	YES	YES	--	YES
		99.8	63.0	POS	POS	YES	YES	YES	YES	--	YES
		120.0	75.7	POS	POS	YES	YES	YES	YES	--	YES
	1024 × 768	60.0	48.4	NEG	NEG	YES	YES	YES	YES*3	STILL	YES
		70.1	56.5	NEG	NEG	YES	YES	YES	YES*3	--	YES
		75.0	60.0	POS	POS	YES	YES	YES	YES*3	STILL	YES
		85.0	68.7	POS	POS	YES	YES	YES	YES*3	--	YES
		100.6	80.5	NEG	NEG	YES	YES	YES	YES*3	--	NO
	1152 × 864	75.0	67.5	POS	POS	YES	YES	YES	YES	STILL	YES
	1280 × 768	56.2	45.1	POS	POS	YES	YES	--	YES	WIDE1	NO
	1360 × 765	60.0	47.7	POS	POS	YES	YES	--	YES	WIDE1	NO
	1360 × 768	60.0	47.7	POS	POS	YES	YES	--	YES	WIDE1	NO
	1376 × 768	59.9	48.3	NEG	POS	YES	YES	--	YES	WIDE2	YES
	1280 × 1024	60.0	64.0	POS	POS	YES	YES	YES*4	YES	--	YES
		75.0	80.0	POS	POS	YES	YES	YES*4	YES	--	NO
85.0		91.1	POS	POS	YES	YES	YES*4	YES	--	NO	
1600 × 1200	60.0	75.0	POS	POS	YES	YES	YES	YES	--	NO	
	65.0	81.3	POS	POS	YES	YES	YES	YES	--	NO	
	70.0	87.5	POS	POS	YES	YES	YES	YES	--	NO	
	75.0	93.8	POS	POS	YES	YES	YES	YES	--	NO	
Work Station (EWS4800)	1280 × 1024	60.0	64.6	NEG	NEG	YES	YES	YES*4	YES	--	YES
		71.2	75.1	NEG	NEG	YES	YES	YES*4	YES	--	NO
Work Station (HP)	1280 × 1024	72.0	78.1	--	--	--	--	YES*4	YES	--	NO
Work Station (SUN)	1152 × 900	66.0	61.8	C Sync	C Sync	--	--	YES	YES	--	NO
		76.0	71.7	C Sync	C Sync	--	--	YES	YES	--	NO
	1280 × 1024	76.1	81.1	C Sync	C Sync	--	--	YES*4	YES	--	NO
Work Station (SGI)	1024 × 768	60.0	49.7	--	--	--	--	YES	YES*3	--	YES
	1280 × 1024	60.0	63.9	--	--	--	--	YES*4	YES	--	YES
IDC-3000G											
PAL625P	768 × 576	50.0	31.4	NEG	NEG	YES	YES	YES*6	YES*6	--	NO
NTSC525P	640 × 480	59.9	31.5	NEG	NEG	YES	YES	YES*6	YES*6	MOTION	NO

- 
- \*1 Only when using a graphic accelerator board that is capable of displaying  $852 \times 480$ .
  - \*2 Display only 640 lines with the screen center of the vertical orientation located at the center.
  - \*3 The picture is displayed in the original resolution.  
The picture will be compressed for other signals.
  - \*4 The aspect ratio is 5:4. This signal is converted to a  $720 \text{ dots} \times 768 \text{ lines}$  signal.
  - \*5 Normally the RGB select mode suited for the input signals is set automatically. If the picture is not displayed properly, set the RGB mode suited for the input signals listed in the table above.
  - \*6 Other screen modes (ZOOM and JUST) are available as well.

---

*NOTE:*

- *While the input signals comply with the resolution listed in the table above, you may have to adjust the position and size of the picture or the fine picture because of errors in synchronization of your computer.*
  - *This display has a resolution of  $1024 \text{ dots} \times 768 \text{ lines}$ . It is recommended that the input signal should be XGA or equivalent.*
  - *With digital input some signals are not accepted.*
  - *The sync may be disturbed when a nonstandard signal other than the aforementioned is input.*
  - *If you are connecting a composite sync signal, use the HD terminal.*
- 

\* “IBM PC/AT” and “XGA” are registered trademarks of International Business Machines, Inc. of the United States.

# Troubleshooting

If the picture quality is poor or there is some other problem, check the adjustments, operations, etc., before requesting service.

Symptom	Checks	Remedy
Picture is disturbed. Sound is noisy. Remote control operates erroneously.	<ul style="list-style-type: none"> <li>Is a connected component set directly in front or at the side of the display?</li> </ul>	<ul style="list-style-type: none"> <li>Leave some space between the display and the connected components.</li> </ul>
The remote controller does not work.	<ul style="list-style-type: none"> <li>Are the remote controller's batteries worn out?</li> </ul>	<ul style="list-style-type: none"> <li>Replace both batteries with new ones.</li> </ul>
Display's power does not turn on when the remote controller's power button is pressed.	<ul style="list-style-type: none"> <li>Is the display's power cord plugged into a power outlet?</li> </ul>	<ul style="list-style-type: none"> <li>Plug the display's power cord into a power outlet.</li> </ul>
	<ul style="list-style-type: none"> <li>Are all the display's indicators off?</li> </ul>	<ul style="list-style-type: none"> <li>Press the power button on the display to turn on the power.</li> </ul>
	<ul style="list-style-type: none"> <li>Are the remote controller's batteries worn out?</li> </ul>	<ul style="list-style-type: none"> <li>Replace both batteries with new ones.</li> </ul>
Display does not operate when the remote controller's buttons are pressed.	<ul style="list-style-type: none"> <li>Is the remote control pointed at the display, or is there an obstacle between the remote controller and the display?</li> </ul>	<ul style="list-style-type: none"> <li>Point the remote controller at the display's remote control sensor when pressing buttons, or remove the obstacle.</li> </ul>
	<ul style="list-style-type: none"> <li>Is direct sunlight or strong artificial light shining on the display's remote control sensor?</li> </ul>	<ul style="list-style-type: none"> <li>Eliminate the light by closing curtains, pointing the light in a different direction, etc.</li> </ul>
	<ul style="list-style-type: none"> <li>Are the remote controller's batteries worn out?</li> </ul>	<ul style="list-style-type: none"> <li>Replace both batteries with new ones.</li> </ul>
	<ul style="list-style-type: none"> <li>The remote cable is plugged into the REMOTE IN terminal (Wired).</li> </ul>	<ul style="list-style-type: none"> <li>Unplug the remote cable from the display.</li> </ul>
	<ul style="list-style-type: none"> <li>The front panel buttons of the main unit do not function.</li> </ul>	<ul style="list-style-type: none"> <li>Set the Control Lock to OFF.</li> </ul>
No sound or picture is produced.	<ul style="list-style-type: none"> <li>Is the display's power cord plugged into a power outlet?</li> </ul>	<ul style="list-style-type: none"> <li>Plug the display's power cord into a power outlet.</li> </ul>
Picture appears but no sound is produced.	<ul style="list-style-type: none"> <li>Is the volume set at the minimum?</li> </ul>	<ul style="list-style-type: none"> <li>Increase the volume.</li> </ul>
	<ul style="list-style-type: none"> <li>Is the mute mode set?</li> </ul>	<ul style="list-style-type: none"> <li>Press the remote controller's MUTE button.</li> </ul>
	<ul style="list-style-type: none"> <li>Are the speakers properly connected?</li> </ul>	<ul style="list-style-type: none"> <li>Connect the speakers properly.</li> </ul>
	<ul style="list-style-type: none"> <li>Is AUDIO INPUT set correctly?</li> </ul>	<ul style="list-style-type: none"> <li>Set AUDIO INPUT on the OPTION menu correctly.</li> </ul>
Poor picture with VIDEO signal input.	<ul style="list-style-type: none"> <li>Improper control setting.</li> <li>Local interference.</li> <li>Cable interconnections.</li> <li>Input impedance is not correct level.</li> </ul>	<ul style="list-style-type: none"> <li>Adjust picture control as needed.</li> <li>Try another location for the display.</li> <li>Be sure all connections are secure.</li> </ul>
Poor picture with RGB signal input.	<ul style="list-style-type: none"> <li>Improper control setting.</li> </ul>	<ul style="list-style-type: none"> <li>Adjust picture controls as needed.</li> </ul>
	<ul style="list-style-type: none"> <li>Incorrect 15 PIN connector pin connections.</li> </ul>	<ul style="list-style-type: none"> <li>Check pin assignments and connections.</li> </ul>
Tint is poor or colors are weak.	<ul style="list-style-type: none"> <li>Are the tint and colors properly adjusted?</li> </ul>	<ul style="list-style-type: none"> <li>Adjust the tint and color (under "PICTURE").</li> </ul>
Nothing appears on screen.	<ul style="list-style-type: none"> <li>Is the computer's power turned on?</li> </ul>	<ul style="list-style-type: none"> <li>Turn on the computer's power.</li> </ul>
	<ul style="list-style-type: none"> <li>Is a source connected?</li> </ul>	<ul style="list-style-type: none"> <li>Connect source to the display.</li> </ul>
	<ul style="list-style-type: none"> <li>Is the power management function in standby or off mode?</li> </ul>	<ul style="list-style-type: none"> <li>Operate the computer (move the mouse, etc.).</li> </ul>
Part of picture is cut off or picture is not centered.	<ul style="list-style-type: none"> <li>Is the position adjustment appropriate?</li> </ul>	<ul style="list-style-type: none"> <li>Adjust the "SCREEN" properly.</li> </ul>
Image is too large or too small.	<ul style="list-style-type: none"> <li>Is the screen size adjustment appropriate?</li> </ul>	<ul style="list-style-type: none"> <li>Press the "WIDE" button on the remote controller and adjust properly.</li> </ul>
Picture is unstable.	<ul style="list-style-type: none"> <li>Is the computer's resolution setting appropriate?</li> </ul>	<ul style="list-style-type: none"> <li>Set to the proper resolution.</li> </ul>
POWER/STANDBY indicator is lighted in orange or red.	<ul style="list-style-type: none"> <li>Horizontal and/or vertical sync signal is not present when the Intelligent Power Manager control is on.</li> </ul>	<ul style="list-style-type: none"> <li>Check the input signal.</li> </ul>
POWER/STANDBY indicator is blinking in red.	<ul style="list-style-type: none"> <li>The temperature inside the main unit has become too high and has activated the overheat protector.</li> </ul>	<ul style="list-style-type: none"> <li>Promptly switch off the power of the main unit and wait until the internal temperature drops. See *1.</li> </ul>
POWER/STANDBY indicator is blinking in green and red, or green.	<ul style="list-style-type: none"> <li>See *2</li> </ul>	<ul style="list-style-type: none"> <li>Promptly switch off the power of the main unit. See *2.</li> </ul>

\*1 If the display becomes too hot, the overheat protector will be activated and the display will be turned off. If this happens, turn off the power to the display and unplug the power cord. If the room where the display is installed is particularly hot, move the display to a cooler location and wait for the display to cool for 60 minutes. If the problem persists, contact your TOSHIBA dealer for service.

\*2 If the display turns off 5 seconds after powering on and then the POWER/STANDBY indicator blinks, the power supply circuit, plasma display panel, or one or more fans have been damaged. If this happens, power off the display immediately and contact your dealer or authorized TOSHIBA Service Center.

# Specifications

<b>Product Name</b>	Plasma Display
<b>Product Code</b>	42HP82
<b>Screen Size</b>	36.1"(H) × 20.4"(V) inches 918(H) × 518(V) mm diagonal 42"
<b>Aspect Ratio</b>	16:9
<b>Resolution</b>	1024(H) × 768(V) pixels
<b>Pixel Pitch</b>	0.04"(H) × 0.03"(V) inches 0.897(H) × 0.675(V) mm
<b>Color Reproduction</b>	256 levels, 16,770,000 colors
<b>Signals</b>	
Synchronization Range	Horizontal : 15.5 to 93.8 kHz (automatic : step scan) Vertical : 50.0 to 120 Hz (automatic : step scan)
Input Signals	RGB, NTSC (3.58/4.43), PAL (B,G,M,N), PAL60, SECAM, HD* <sup>1</sup> , DVD* <sup>1</sup> , DTV* <sup>1</sup>

## Input Terminals

### RGB

Visual 1 (Analog)	mini D-sub 15-pin × 1
Visual 2 (Analog)	BNC (R, G, B, H/CS, V) × 1* <sup>2</sup>
Visual 3 (Digital)	DVI-I 29-pin × 1* <sup>3</sup> (Not compatible with analog input)

### Video

Visual 1	RCA-pin × 1
Visual 2	S-Video: DIN 4-pin × 1
Visual 3	BNC (G/Y/VIDEO3) × 1* <sup>2</sup>

### DVD/HD/DTV

Visual 1	RCA-pin (Y, PB[CB], PR[CR]) × 1* <sup>1</sup>
Visual 2	BNC (Y, PB[CB], PR[CR]) × 1* <sup>1, *2</sup>

### Audio

Stereo RCA × 3(selectable)

### External Control

D-sub 9-pin × 1(RS-232C)

### Sound output

7W+7W at 6 ohm

### Power Supply

AC120V 50/60Hz

### Current Rating

5.0A (maximum)

### Power Consumption

380W (typical)

### Dimensions

41.3 (W) × 25.5 (H) × 3.5 (D) inches

1048 (W) × 648 (H) × 89(D) mm

### Mass

65.0 lbs / 29.5 kg

### Environmental Considerations

Operating Temperature	0°C to 40°C / 32°F to 104°F
Humidity	20 to 80% (no condensation)
Storage Temperature	-10°C to 50°C / 14°F to 122°F
Humidity	10 to 90% (no condensation)

### Front Panel User Controls

Power on/off, Input source select,  
Volume up/down, OSD control

### Remote Control Functions

Power on/off, Input source select, OSD  
control, Volume up/down, Cursor (UP,  
DOWN, LEFT, RIGHT), Pointer, Zoom up/  
down, Off timer, Wireless/ Wired remote  
control

### OSD Functions

Picture (Contrast / Brightness / Sharpness/  
Color / Tint / Picture mode / Color  
temperature/ Noise reductions), Sound (Bass  
/ Treble/ Balance), Screen (V-Position / H-  
Position/ V-Height / H-Width / Auto Picture  
/ Fine picture/ Picture adjustment), Function  
(OSD/ OSD adjustment/ Power  
management/ Gray level/ Cinema mode/  
RGB3 Adjustment, Long Life (PLE, Orbiter,  
Inverse, White, Screen Wiper)/ Reset)/Option  
(Audio input/ BNC select/ RGBselect/ HD  
select), Information (Frequency / Language\*  
/ Color system)

\*English, German, French, Italian, Spanish,  
Swedish, Chinese

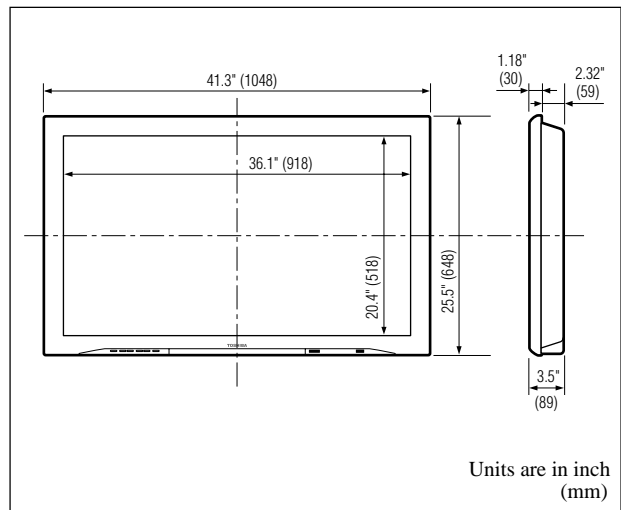

The features and specifications may be subject to change without notice.

### \*<sup>1</sup> HD/DVD/DTV input signals supported on this system

480P (60 Hz)	480I (60 Hz)
525P (60 Hz)	525I (60 Hz)
576P (50 Hz)	576I (50 Hz)
625P (50 Hz)	625I (50 Hz)
720P (60 Hz)	1035I (60 Hz)
1080I (50 Hz)	1080I (60 Hz)

\*<sup>2</sup> The 5-BNC connectors are used as RGB/PC2, HD/DVD2 and VIDEO3 input. Select one of them under "BNC SELECT".

\*<sup>3</sup> Input signals from PC's available VGA only.

### Other Features

3D motion adaptive Scan Converter with 2-2 (50Hz), 2-3 (60Hz) pull down Converter, Digital Zoom function (100-900% Selectable), Self Diagnosis, Anti Image Burn, Color Temperature Select, Control Lock, Power management, Plug and play (DDC1, DDC2b, RGB3: DDC2b only)

### Accessories

Remote controller with two AAA batteries, Remote cable, RGB cable (Mini D-Sub 15-pin to Mini D-Sub 15-pin connector), Power cord, Owner's Manual, Safety metal fittings, Screw for Safety metal fittings, Ferrite cores, Bands, BNC-RCA Adapter (× 3)

# FCC STATEMENT

**MODEL:42HP82**

## FCC STATEMENT

This equipment has been tested and found to comply with the limits for a Class B digital device, pursuant to Part 15 of the FCC Rules. These limits are designed to provide reasonable protection against harmful interference in a residential installation. This equipment generates, uses and can radiate radio frequency energy and, if not installed and used in accordance with the instructions, may cause harmful interference to radio communications. However, there is no guarantee that interference will not occur in a particular installation. If this equipment does cause harmful interference to radio or television reception, which can be determined by turning the equipment off and on, the user is encouraged to try to correct the interference by one of the following measures:

- Reorient or relocate the receiving antenna.
- Increase the separation between the equipment and receiver.
- Connect the equipment into an outlet on a circuit different from that to which the receiver is connected.
- Consult the dealer or an experienced radio/TV technician for help.

This device complies with Part 15 of the FCC Rules. Operation is subject to the following two conditions: (1)

This device may not cause harmful interference, and (2) this device must accept any interference received, including interference that may cause undesired operation.

### FCC CAUTION:

**To ensure continued compliance and to avoid possible undesirable interference, the provided ferrite cores must be used when connecting this Wide Plasma Display to video equipment; and maintain at least 15.75" (40 cm) of space from other peripheral devices. Refer to instructions on page 4. Any changes or modifications not expressly approved by Toshiba America Consumer Products, Inc. could cause harmful interference and may void the user's authority to operate this device.**

### FCC Declaration of Conformity

Responsible Party: Toshiba America Consumer Products, Inc.  
1420 Toshiba Drive, Lebanon, TN 37087

Contact Source: Toshiba America Consumer Products, Inc.  
1420 Toshiba Drive, Lebanon, TN 37087  
1-800-631-3811

### CANADIAN NOTICE:

This Class B digital apparatus complies with Canadian ICES-003.

# Limited United States Warranty for Wide Plasma Display

Toshiba America Consumer Products, Inc. ("TACP") and Toshiba Hawaii, Inc. ("THI") make the following limited warranties to original consumers in the United States. **THESE LIMITED WARRANTIES EXTEND TO THE ORIGINAL CONSUMER PURCHASER OR ANY PERSON RECEIVING THIS PLASMA DISPLAY AS A GIFT FROM THE ORIGINAL CONSUMER PURCHASER AND TO NO OTHER PURCHASER OR TRANSFEREE.**

**PRODUCTS PURCHASED IN THE U.S.A. AND USED IN CANADA ARE NOT COVERED BY THESE WARRANTIES.**

**PRODUCTS PURCHASED IN CANADA AND USED IN THE U.S.A. ARE NOT COVERED BY THESE WARRANTIES.**

## Limited One (1) Year Warranty on Parts and Labor\*

TACP/THI warrant this plasma display and its parts against defects in materials or workmanship for a period of one (1) year after the date of original retail purchase. **DURING THIS PERIOD, TACP/THI WILL, AT TACP/THI'S OPTION, REPAIR OR REPLACE A DEFECTIVE PART WITH A NEW OR REFURBISHED PART WITHOUT CHARGE TO YOU FOR PARTS OR LABOR.** TACP/THI Authorized Service Station personnel will come to your home when warranty service is required. Depending on the type of repair required, either the service will be performed in your home or the set will be taken to the TACP/THI Authorized Service Station for repair and returned to your home at no cost to you.

## Rental Units

The warranty for rental units begins with the date of first rental or thirty (30) days from the date of shipment to the rental firm, whichever comes first.

## \*Commercial Units

Plasma displays sold and used for commercial purposes have a limited ninety (90) day warranty for all parts, labor.

## Owner's Manual and Product Registration Card

Read this owner's manual thoroughly before operating this plasma display. Complete and mail the enclosed product registration card within ten days after you, or the person who has given you this product as a gift, purchased this plasma display. Returning the product registration card will enable TACP/THI to provide you with better customer service and improved product support. Failure to return the product registration card will not affect your rights under this warranty.

## Your Responsibility

**THE ABOVE WARRANTIES ARE SUBJECT TO THE FOLLOWING CONDITIONS:**

- (1) You must provide your bill of sale or other proof of purchase.
- (2) All warranty servicing of this plasma display must be made by an Authorized TACP/THI Service Station.
- (3) The warranties from TACP and THI are effective only if the plasma display is purchased and operated in the U.S.A. or Puerto Rico.
- (4) Labor service charges for set installation, setup, adjustment of customer controls, and installation are not covered by these warranties.
- (5) Warranties extend only to defects in materials or workmanship as limited above and do not extend to any plasma display or parts that have been lost or discarded by you or to damage to plasma display or parts caused by misuse, accident, Acts of God (such as lightning or fluctuations in electric power), improper installation, improper maintenance, or use in violation of instructions furnished by TACP/THI; or to units that have been modified or had the serial number removed, altered, defaced, or rendered illegible.

## How to Obtain Warranty Services

If, after following all of the operating instructions in this manual and checking the "Troubleshooting" section, you find that service is needed:

- (1) To find the nearest TACP/THI Authorized Service Station: For plasma displays purchased in the United States, except Hawaii, visit TACP's web site at [www.toshiba.com/tacp](http://www.toshiba.com/tacp), or call toll free 1-800-631-3811. For plasma displays purchased in Hawaii, contact Toshiba Hawaii, Inc., 327 Kamakee Street, Honolulu, HI 96814, (808) 591-9281.
- (2) Present your bill of sale or other proof of purchase to the Authorized Service Station. Authorized TACP/THI Service Station personnel will come to your home when warranty service is required. Depending on the type of repair required, either the service will be performed in your home or the set will be taken to the Authorized Service Station for repair and returned to your home at no cost to you.

For additional information, visit TACP's web site:  
[www.toshiba.com/tacp](http://www.toshiba.com/tacp)

**ALL WARRANTIES IMPLIED BY THE LAW OF ANY STATE OF THE U.S.A., INCLUDING THE IMPLIED WARRANTIES OF MERCHANTABILITY AND FITNESS FOR A PARTICULAR PURPOSE, ARE EXPRESSLY LIMITED TO THE DURATION OF THE LIMITED WARRANTIES SET FORTH ABOVE. WITH THE EXCEPTION OF ANY WARRANTIES IMPLIED BY THE LAW OF ANY STATE OF THE U.S.A. AS HEREBY LIMITED, THE FOREGOING WARRANTY IS EXCLUSIVE AND IN LIEU OF ALL OTHER WARRANTIES, GUARANTEES, AGREEMENTS, AND SIMILAR OBLIGATIONS OF TACP OR THI WITH RESPECT TO THE REPAIR OR REPLACEMENT OF ANY PARTS. IN NO EVENT SHALL TACP OR THI BE LIABLE FOR CONSEQUENTIAL OR INCIDENTAL DAMAGES.**

No person, agent, distributor, dealer, or company is authorized to change, modify, or extend the terms of these warranties in any manner whatsoever. The time within which action must be commenced to enforce any obligation of TACP or THI arising under this warranty or under any law of the United States or of any state thereof is hereby limited to 90 days from the date you discover, or should have discovered, the defect. This limitation does not apply to implied warranties arising under the law of any state of the U.S.A.

**THIS WARRANTY GIVES YOU SPECIFIC LEGAL RIGHTS, AND YOU MAY ALSO HAVE OTHER RIGHTS, WHICH MAY VARY FROM STATE TO STATE IN THE U.S.A. SOME STATES OF THE U.S.A. DO NOT ALLOW LIMITATIONS ON THE DURATION OF AN IMPLIED WARRANTY, LIMITATIONS ON THE TIME WITHIN WHICH AN ACTION MAY BE BROUGHT, OR THE EXCLUSION OR LIMITATION OF INCIDENTAL OR CONSEQUENTIAL DAMAGES; THEREFORE, THE ABOVE LIMITATIONS OR EXCLUSIONS MAY NOT APPLY TO YOU UNDER SUCH CIRCUMSTANCES.**

REV. JUN02



# Limited Canada Warranty for Wide Plasma Display

Toshiba of Canada Limited ("TCL") makes the following limited warranties to original consumers in Canada.

**THESE LIMITED WARRANTIES EXTEND TO THE ORIGINAL CONSUMER PURCHASER OR ANY PERSON RECEIVING THIS PLASMA DISPLAY AS A GIFT FROM THE ORIGINAL CONSUMER PURCHASER AND TO NO OTHER PURCHASER OR TRANSFEREE.**

**PRODUCTS PURCHASED IN THE U.S.A. AND USED IN CANADA ARE NOT COVERED BY THESE WARRANTIES.**

**PRODUCTS PURCHASED IN CANADA AND USED IN THE U.S.A. ARE NOT COVERED BY THESE WARRANTIES.**

## Limited One (1) Year Warranty on Parts and Labor\*

TCL warrants this plasma display and its parts against defects in materials or workmanship for a period of one (1) year after the date of original retail purchase. **DURING THIS PERIOD, TCL WILL, AT TCL'S OPTION, REPAIR OR REPLACE A DEFECTIVE PART WITH A NEW OR REFURBISHED PART WITHOUT CHARGE TO YOU FOR PARTS OR LABOR.** TCL Authorized Service Depot personnel will come to your home when warranty service is required. Depending on the type of repair required, either the service will be performed in your home or the set will be taken to the TCL Authorized Service Depot for repair and returned to your home at no cost to you. **IN-HOME SERVICE ONLY APPLIES WITHIN 100 KILOMETERS OF AN AUTHORIZED TCL SERVICE DEPOT.**

## Rental Units

The warranty for rental units begins with the date of first rental or thirty (30) days from the date of shipment to the rental firm, whichever comes first.

## \*Commercial Units

Plasma displays sold and used for commercial purposes have a limited ninety (90) day warranty for all parts, labor.

## Owner's Manual

Read this owner's manual thoroughly before operating this plasma display.

## Your Responsibility

**THE ABOVE WARRANTIES ARE SUBJECT TO THE FOLLOWING CONDITIONS:**

- (1) You must provide your bill of sale or other proof of purchase.
- (2) All warranty servicing of this plasma display must be made by an Authorized TCL Service Depot.
- (3) The warranties from TCL are effective only if the plasma display is purchased in Canada from an authorized TCL dealer and operated in Canada.
- (4) Labor service charges for set installation, setup, adjustment of customer controls, and installation are not covered by these warranties.
- (5) Warranties extend only to defects in materials or workmanship as limited above and do not extend to any plasma display or parts that have been lost or discarded by you or to damage to plasma display or parts caused by misuse, accident, Acts of God (such as lightning or fluctuations in electric power), improper installation, improper maintenance, or use in violation of instructions furnished by TCL; or to units that have been modified or had the serial number removed, altered, defaced, or rendered illegible.

## How to Obtain Warranty Services

If, after following all of the operating instructions in this manual and checking the "Troubleshooting" section, you find that service is needed:

- (1) To find the nearest TCL Authorized Service Depot, visit TCL's web site: [www.toshiba.ca](http://www.toshiba.ca).
- (2) Present your bill of sale or other proof of purchase to the Authorized Service Depot. Authorized TCL Service Depot personnel will come to your home when warranty service is required. Depending on the type of repair required, either the service will be performed in your home or the set will be taken to the Authorized Service Depot for repair and returned to your home at no cost to you. **IN-HOME SERVICE ONLY APPLIES WITHIN 100 KILOMETERS OF AN AUTHORIZED TCL SERVICE DEPOT.**

For additional information, visit TCL's web site:  
[www.toshiba.ca](http://www.toshiba.ca).

**ALL WARRANTIES IMPLIED BY THE LAW OF ANY PROVINCE OF CANADA, INCLUDING THE IMPLIED WARRANTIES OF MERCHANTABILITY AND FITNESS FOR A PARTICULAR PURPOSE, ARE EXPRESSLY LIMITED TO THE DURATION OF THE LIMITED WARRANTIES SET FORTH ABOVE. WITH THE EXCEPTION OF ANY WARRANTIES IMPLIED BY THE LAW OF ANY PROVINCE OF CANADA AS HEREBY LIMITED, THE FOREGOING WARRANTY IS EXCLUSIVE AND IN LIEU OF ALL OTHER WARRANTIES, GUARANTEES, AGREEMENTS, AND SIMILAR OBLIGATIONS OF TCL WITH RESPECT TO THE REPAIR OR REPLACEMENT OF ANY PARTS. IN NO EVENT SHALL TCL BE LIABLE FOR CONSEQUENTIAL OR INCIDENTAL DAMAGES.**

No person, agent, distributor, dealer, or company is authorized to change, modify, or extend the terms of these warranties in any manner whatsoever. The time within which action must be commenced to enforce any obligation of TCL arising under this warranty or under any law of Canada or of any province thereof, is hereby limited to 90 days from the date you discover, or should have discovered, the defect. This limitation does not apply to implied warranties arising under the law of any province of Canada.

**THIS WARRANTY GIVES YOU SPECIFIC LEGAL RIGHTS, AND YOU MAY ALSO HAVE OTHER RIGHTS, WHICH MAY VARY FROM PROVINCE TO PROVINCE IN CANADA. SOME PROVINCES OF CANADA DO NOT ALLOW LIMITATIONS ON THE DURATION OF AN IMPLIED WARRANTY, LIMITATIONS ON THE TIME WITHIN WHICH AN ACTION MAY BE BROUGHT, OR THE EXCLUSION OR LIMITATION OF INCIDENTAL OR CONSEQUENTIAL DAMAGES; THEREFORE, THE ABOVE LIMITATIONS OR EXCLUSIONS MAY NOT APPLY TO YOU UNDER SUCH CIRCUMSTANCES.**

REV. JUN02

## **TOSHIBA AMERICA CONSUMER PRODUCTS, INC.**

SERVICE DIVISION/82 TOTOWA ROAD, WAYNE, NEW JERSEY 07470  
NATIONAL SERVICE DIVISION: 1420B TOSHIBA DRIVE, LEBANON, TN. 37087  
"www.toshiba.com/tacp"

## **TOSHIBA HAWAII, INC.**

SERVICE DIVISION/327 KAMAKEE STREET, HONOLULU, HAWAII 96814, U.S.A. TEL: (808) 591-9281

## **TOSHIBA OF CANADA LTD.**

HEAD OFFICE/191 McNABB STREET MARKHAM, ONTARIO L3R 8H2, CANADA TEL: (905) 470-5400  
SERVICE CENTERS/TORONTO: 191 McNABB STREET MARKHAM, ONTARIO L3R 8H2, CANADA TEL: (905) 470-5400  
MONTREAL: 1643, NORTH SERVICE RD., TRANS-CANADA HIGHWAY, DORVAL QUEBEC, H9P 1J1, CANADA  
TEL: (514) 856-4100  
VANCOUVER: 22171 FRASERWOOD WAY, RICHMOND, B.C. V6W 1J5, CANADA TEL: (604) 303-2500

ColorStream and TheaterWide are registered trademarks of Toshiba America Consumer Products, Inc.

PRINTED IN JAPAN  
(02-06)

# **TOSHIBA**

7S800761