

Type 657 Diaphragm Actuator Sizes 30-70 and 87

Contents

Introduction	1
Scope of Manual	1
Description	2
Specifications	2
Installation	3
Mounting the Actuator on the Valve	4
Discussion of Bench Set	5
Spring Verification	5
Installing the Stem Connector Assembly	6
Deadband Measurement	6
Loading Connection	8
Maintenance	8
Actuator Maintenance	8
Top-Mounted Handwheel Assembly	10
Side-Mounted Handwheel for Sizes 34 through 60 Actuators	11
Side-Mounted Handwheel for Sizes 70 and 87 Actuators	12
Casing-Mounted Adjustable Travel Stops	14
Parts Ordering	15
Parts Kits	17
Kits for Side-Mounted Handwheels	17
Kits for Top-Mounted Handwheels	17
Parts List	17
Actuator Assembly (figures 6, 7, or 8)	17
Top-Mounted Handwheel (figures 9 or 10) ..	18
Side-Mounted Handwheel (figure 11 or 13) ..	18
Casing-Mounted Adjustable Up Travel Stops (figures 14 or 15)	22
Casing-Mounted Adjustable Down Travel Stops (figure 16)	23

Introduction

Scope of Manual

This instruction manual provides information on installation, adjustment, maintenance, and parts ordering for the Type 657 actuator in sizes 30



Figure 1. Type 657 or 657-4 Actuator Mounted on an easy-e® Valve

through 70 and size 87. The Type 657-4 actuator in sizes 70 and 87 is also covered. Refer to separate instruction manuals for information about the valve positioner and other accessories used with these actuators.

Do not install, operate, or maintain a Type 657 actuator without first • being fully trained and qualified in valve, actuator, and accessory installation, operation, and maintenance, and • carefully reading and understanding the contents of this manual. If you have any questions about these instructions, contact your Emerson Process Management™ sales office before proceeding.



657 Actuator (30-70 and 87)

Table 1. Specifications

SPECIFICATION ⁽¹⁾		ACTUATOR SIZE								
		30	34	40	45	46	50	60	70 ⁽¹⁾	87 ⁽¹⁾
Nominal Effective Area	cm ²	297	445	445	677	1006	677	1006	1419	1419
	Inch ²	46	69	69	105	156	105	156	220	220
Yoke Boss Diameters	mm	54	54	71	71	71	90	90	90	127
	Inches	2-1/8	2-1/8	2-13/16	2-13/16	2-13/16	3-9/16	3-9/16	3-9/16	5
Acceptable Valve Stem Diameters	mm	9.5	9.5	12.7	12.7	12.7	19.1	19.1	19.1	25.4
	Inches	3/8	3/8	1/2	1/2	1/2	3/4	3/4	3/4	1
Maximum Allowable Output Thrust ⁽⁴⁾	N	10230	10230	12010	25131	33582	25131	30246	39142	39142
	Lb	2300	2300	2700	5650	7550	5650	6800	8800	8800
Maximum Travel ⁽²⁾	mm	19	29	38	51	51	51	51	76 ⁽³⁾	76 ⁽³⁾
	Inches	0.75	1.125	1.5	2	2	2	2	3 ⁽³⁾	3 ⁽³⁾
Maximum Casing Pressure for Actuator Sizing ⁽⁴⁾	Bar	8.6	4.5	4.5	3.4	2.8	3.4	2.8	3.8	3.8
	Psig	125	65	65	50	40	50	40	55	55
Maximum Diaphragm Casing Pressure ⁽⁴⁾⁽⁵⁾	Bar	9.6	5.2	5.2	4.1	3.4	4.1	3.4	4.5	4.5
	Psig	140	75	75	60	50	60	50	65	65
Material Temperature Capabilities	°C	Nitrile Elastomers: -40 to 82°C, Silicone Elastomers: -54 to 149°C, Fluorocarbons: -18 to 149°C								
	°F	Nitrile Elastomers: -40 to 180°F, Silicone Elastomers: -65 to 300°F, Fluorocarbons: 0 to 300°F								
Pressure Connections (female)	1/4 In. NPT	X	X	X	X	X	X	X	---	---
	1/2 In. NPT	---	---	---	---	---	---	---	X	X
Approximate Weights	kg	16	22	23	37	49	42	53	107	116
	Lb	36	48	51	82	107	92	116	235	255

1. These values also apply to the Type 657-4 actuator construction.
2. Actuator travel may be less than the value listed after connecting the actuator to the valve.
3. Maximum travel for Type 657-4 is 102 mm (4 inches).
4. Normal operating diaphragm pressure must not exceed maximum diaphragm casing pressure and must not produce a force on the actuator stem greater than the maximum allowable output thrust or the maximum allowable valve stem load. Contact your Emerson Process Management sales office with questions concerning maximum allowable valve stem load.
5. This maximum casing pressure is not to be used for normal operating pressure. Its purpose is to allow for typical regulator supply settings and/or relief valve tolerances.

Note

Neither Emerson, Emerson Process Management, nor any of their affiliated entities assumes responsibility for the selection, use and maintenance of any product. Responsibility for the selection, use, and maintenance of any product remains with the purchaser and end-user.

assembly. A top-mounted handwheel assembly is used as an adjustable up travel stop to limit actuator travel in the up direction (see figure 2). A side-mounted handwheel assembly is usually used as an auxiliary manual actuator. Adjustable casing-mounted up or down travel stops are also available for this actuator.

Note

If repeated or daily manual operation is expected, the actuator should be equipped with a side-mounted handwheel rather than a casing-mounted travel stop or top-mounted handwheel.

The side-mounted handwheel is designed for more frequent use as a manual operator.

Description

The Type 657 actuator (figure 1) and the Type 657-4 actuator are direct-acting, spring-opposed diaphragm actuators. They provide automatic operation of control valve body assemblies. The Type 657 actuator offers 76 mm (3 inches) maximum actuator travel. The Type 657-4 actuator provides 102 mm (4 inches) maximum actuator travel. Both actuators position the valve plug in response to varying pneumatic loading pressure on the actuator diaphragm. Figure 2 shows the operation of these actuators.

A Type 657 or 657-4 actuator can be equipped with either a top-mounted or a side-mounted handwheel

Specifications

Refer to table 1 for Specifications of the Type 657 and 657-4 actuators. See the actuator nameplate for specific information about your actuator.

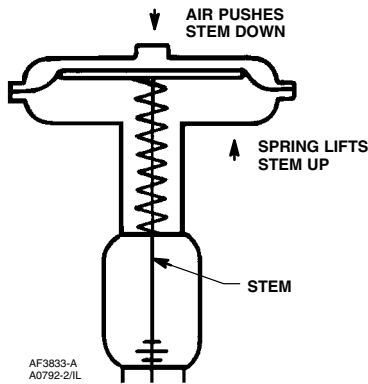

Figure 2. Schematic of Type 657 and 657-4 Actuators

Installation

Key number locations are shown in figures 6, 7, and 8, unless otherwise indicated. Also, refer to figure 3 for location of parts.

WARNING

Always wear protective gloves, clothing, and eyewear when performing any installation operations to avoid personal injury.

Check with your process or safety engineer for any additional measures that must be taken to protect against process media.

If installing into an existing application, also refer to the **WARNING** at the beginning of the Maintenance section in this instruction manual.

CAUTION

To avoid parts damage, do not use an operating pressure that exceeds the Maximum Diaphragm Casing Pressure (table 1) or produces a force on the actuator stem greater than the Maximum Allowable Output Thrust (table 1) or the maximum allowable valve stem load. (Contact your Emerson Process Management sales office with questions concerning maximum allowable valve stem load.)

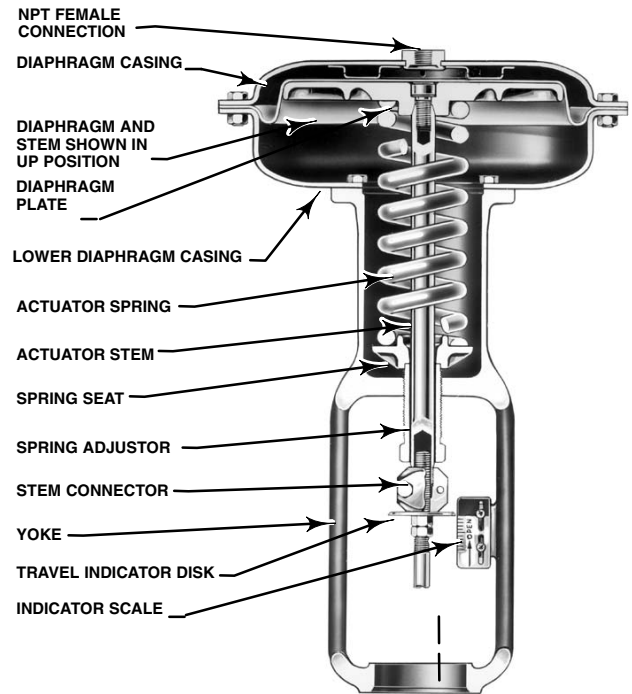

W0363-1/LL

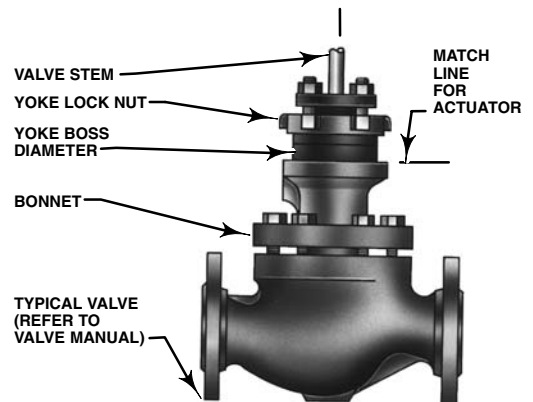

W6199-1/LL

Figure 3. Actuator Mounting Components for Size 30 through 70 Actuators

- Valve/Actuator Assembly:** If the actuator and valve are shipped together as a control valve assembly, it has been adjusted at the factory, and may be installed in the pipeline. After installing the valve in the pipeline, refer to the Loading Connection procedures.

- Actuator Mounting:** If the actuator is shipped separately or the actuator has been removed from the valve, it is necessary to mount the actuator on the valve before placing the valve in the pipeline. Refer to the actuator mounting procedures before placing the valve in service. You may perform the Bench Set Spring Adjustment procedures in this

657 Actuator (30-70 and 87)

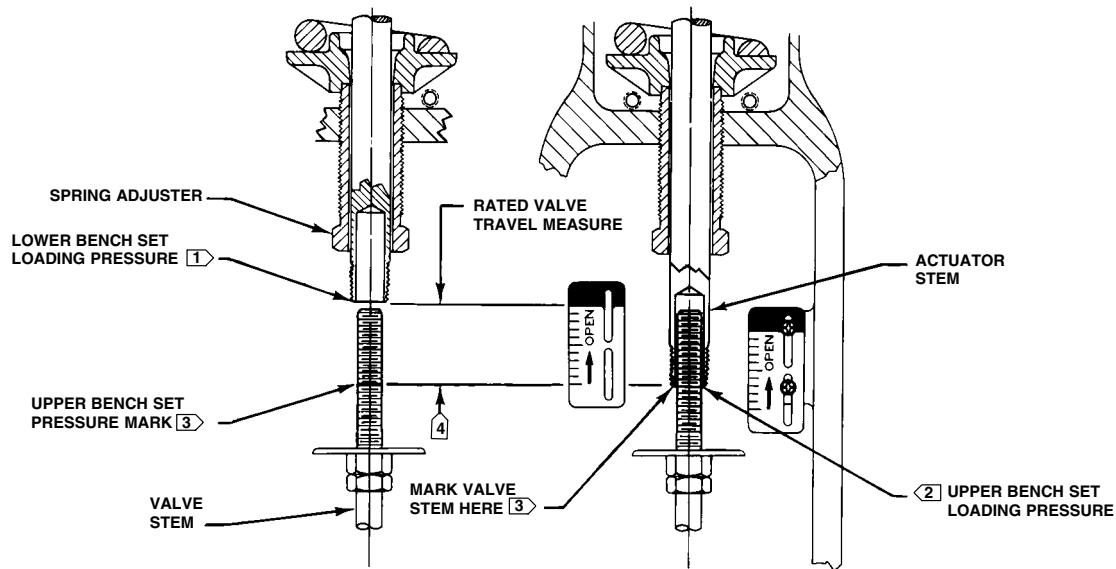

- NOTES:
- 1 THE LOWER PSIG LOADING PRESSURE (MARKED ON NAMEPLATE) WHERE THE FIRST MOVEMENT OF ACTUATOR STEM IS DETECTED.
 - 2 THE UPPER PSIG LOADING PRESSURE EXTEND ACTUATOR STEM.
 - 3 MARK THIS POINT WITH TAPE OR A MARKER.
 - 4 MEASURE DISTANCE OF TRAVEL. IT SHOULD EQUAL THE TRAVEL SPAN SHOWN ON THE TRAVEL INDICATOR SCALE.

40A8715-B
B2426 / IL

Figure 4. Bench Set Adjustment

section to confirm that the adjustment has not changed since it was shipped from the factory.

- **Positioner:** If a positioner is installed, or is to be installed on the actuator, refer to the positioner instruction manual for installation. During the adjustment procedures, it will be necessary to provide a temporary loading pressure to the actuator diaphragm.

Mounting the Actuator on the Valve

The Type 657 actuator spring loading pushes the actuator stem up towards the actuator diaphragm (see figure 2). This spring action moves the stem away from the valve while installing the actuator.

CAUTION

If the valve stem is allowed to remain in the up position (towards the actuator) during mounting, it can interfere with the actuator mounting, possibly damage valve stem threads or bend the valve stem. Be sure the valve stem is pushed down (into the

valve body), away from the actuator while mounting.

Provide a temporary method of applying diaphragm loading pressure to the diaphragm to extend the actuator stem during bench set spring adjustments.

1. Provide a vise or some other method of supporting the valve and the weight of the actuator during assembly. For direct or reverse acting valves, push the valve stem down away from the actuator while mounting the actuator.
2. Screw the stem locknuts all the way onto the valve stem. With the concave side of the travel indicator disk (key 14) facing the valve, install the travel indicator disk on the valve stem. (Note: The travel indicator disk is not used with size 87 actuators.)
3. Lift or hoist the actuator onto the valve bonnet:
 - a. **For size 87 actuators,** insert the cap screws and tighten the hex nuts, securing the actuator to the bonnet.
 - b. **For all other size actuators,** screw the yoke locknut onto the valve bonnet and tighten the locknut. (Note: On small size actuators, it may be necessary to remove the indicator disk and re-install it while lowering the actuator on to the

valve because the disk will not go through the actuator yoke opening).

4. Do **not** connect the actuator stem to the valve stem at this time. Whenever the actuator is installed on the valve, it is recommended to perform the Bench Set Spring Adjustment procedure to verify that the actuator is still adjusted correctly.

Discussion of Bench Set

The bench set pressure range is used to adjust the initial compression of the actuator spring with the valve-actuator assembly “on the bench.” The correct initial compression is important for the proper functioning of the valve-actuator assembly when it is put into service and the proper actuator diaphragm operating pressure is applied.

The bench set range is established with the assumption that there is no packing friction. When attempting to adjust the spring in the field, it is very difficult to ensure that there is no friction being applied by “loose” packing.

Accurate adjustment to the bench set range can be made during the actuator mounting process by making the adjustment before the actuator is connected to the valve (see the Spring Verification Procedure).

If you are attempting to adjust the bench set range after the actuator is connected to the valve and the packing tightened, you must take friction into account. Make the spring adjustment such that full actuator travel occurs at the bench set range (a) plus the friction force divided by the effective diaphragm area with increasing diaphragm pressure or (b) minus the friction force divided by the effective diaphragm area with decreasing diaphragm pressure.

For an assembled valve-actuator assembly, the valve friction may be determined by following the procedure described below:

1. Install a pressure gauge in the actuator loading pressure line that connects to the actuator diaphragm casing.

Note

Steps 2 and 4 require that you read and record the pressure shown on the pressure gauge.

2. Increase the actuator diaphragm pressure and read the diaphragm pressure as the actuator reaches its mid-travel position.

3. Increase the actuator diaphragm pressure until the actuator is at a travel position greater than its mid-travel position.

4. Decrease the actuator diaphragm pressure and read the diaphragm pressure as the actuator reaches its mid-travel position.

The difference between the two diaphragm pressure readings is the change in the diaphragm pressure required to overcome the friction forces in the two directions of travel.

5. Calculate the actual friction force:

$$\text{Friction Force, pounds} = 0.5 \left(\begin{array}{c} \text{Difference} \\ \text{in pressure} \\ \text{readings, psig} \end{array} \right) \times \left(\begin{array}{c} \text{Effective} \\ \text{diaphragm area,} \\ \text{inches}^2 \end{array} \right)$$

Refer to table 1 for the effective diaphragm area.

When determining valve friction, you can make diaphragm pressure readings at a travel position other than mid-travel if you desire. If you take readings at zero or at the full travel position, take extra care to ensure that the readings are taken when the travel just begins or just stops at the position selected.

It is difficult to rotate the spring adjustor (key 12, figure 6, 7, and 8) when the full actuator loading pressure is applied to the actuator. Release the actuator loading pressure before adjusting. Then re-apply loading pressure to check the adjustment.

Spring Verification

Ensure that the actuator stem is at the top of its travel as shown in figure 4 and not connected to the valve. (Note: Some spring compression is required to move the diaphragm to the **top** of its travel.) The bench set steps provided are the same for direct or reverse acting valves.

WARNING

When moving the actuator stem with diaphragm loading pressure, use caution to keep hands and tools out of the actuator stem travel path. Personal injury and/or property damage is possible if something is caught between the actuator stem and other control valve assembly parts.

Also, provide a certified pressure gauge suitable to accurately read the diaphragm pressure from 0 through the upper bench set pressure marked on the

657 Actuator (30-70 and 87)

nameplate. Apply loading pressure to the diaphragm.

CAUTION

Stroke the actuator a few times to ensure that the pressure gauge is working correctly, and that the actuator is functioning properly. To prevent product damage, it is important to be sure that the actuator assembly is not binding or producing any loading friction on the actuator stem movement.

1. If not already accomplished, provide a temporary means of applying an adjustable loading pressure to the actuator during bench set adjustments.
2. Set the diaphragm loading pressure at 0 psig. Then, slowly raise the pressure from 0 psig towards the lower bench set pressure while checking for the first movement of the actuator stem. The actuator stem should show movement at the lower bench set pressure. If movement occurs before or after the lower pressure is reached, adjust the spring adjuster (see figure 4) into or out of the yoke until the actuator stem's movement is **first** detected at the lower bench set pressure.
3. Be sure the spring adjuster is adjusted to meet the requirements of step 2 above.
4. Apply the upper bench set loading pressure to the diaphragm. This pressure extends the actuator stem down towards the valve. (Note: the actuator stem may slide over the valve stem as shown in figure 4.) At the end of the actuator stem, use a marker or a piece of tape to mark the valve stem (see figure 4). (Note: If the actuator stem does not pass over the valve stem, provide a method to mark this point of stem travel.)
5. Slowly decrease the diaphragm loading pressure until the lower bench set pressure is applied. Measure the distance between the marker or tape on the valve stem to the end of the actuator stem. The distance should match the travel span shown on the travel indicator scale (key 18). If the span of travel is correct, bench set is complete. Proceed to the Installing the Stem Connector Assembly subsection.
6. If the travel span is **not** correct, a wrong or damaged spring has been installed in the actuator. To obtain the correct spring sizing information, refer to Catalog 14, Actuator Sizing and Sample Calculation sections to determine the correct spring

selection for your application. Or, contact your Emerson Process Management sales office for assistance. After replacing the spring, repeat the steps above.

Installing the Stem Connector Assembly

When installing the stem connector assembly (key 26), the actuator and valve stem threads should engage the threads of the stem connector by the distance of the diameter of the stem.

Note

Replacement stem connectors are an assembly of two stem connector halves, cap screws, and a spacer between the connector halves. Remove the spacer and discard, if present, before clamping the actuator and valve stems together.

1. If necessary, push the valve stem down so that it is touching the seat ring on direct acting valves. For reverse acting valves, push the stem down to the open position.

If necessary, screw the valve stem locknuts down, away from the connector location. For all actuators except size 87, ensure that the travel indicator disk (key 14) is located on top of the locknuts.

2. Slowly increase the diaphragm pressure to the upper bench set pressure. This should be the same pressure used in the bench set steps, and it is marked on the nameplate.
3. Place the stem connector half with the threaded holes, approximately half way between the actuator and valve stems. Refer to figures 6, 7, and 8 to help locate the connector position.

Be sure that the actuator and valve stem threads are engaging the threads of the stem connector by the distance of one diameter of the stem.

CAUTION

Incomplete engagement of either the valve stem or actuator stem in the stem connector can result in stripped threads or improper operation. Be sure that the length of each stem clamped in the stem connector is equal to or greater than one diameter of that stem. Damage to threads on either stem or in the stem connector can cause the parts to be replaced prematurely.

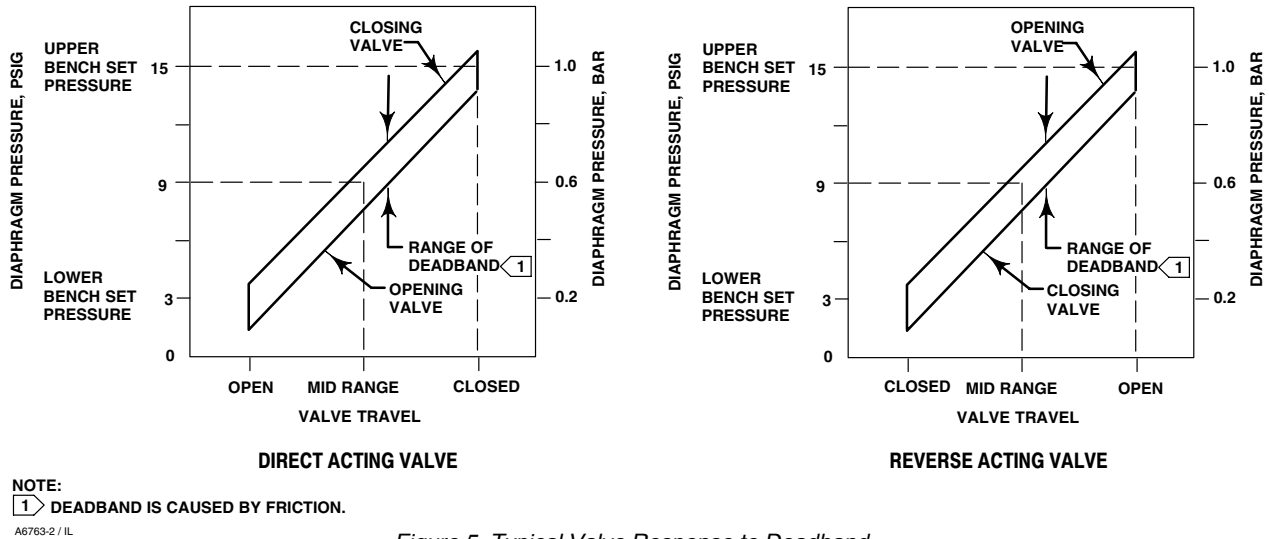

Figure 5. Typical Valve Response to Deadband

4. Install the other half of the stem connector and insert the cap screws and tighten them. If installing a positioner, also attach the feedback bracket at the same time.
5. Screw the valve stem locknuts up until the indicator disk contacts the bottom of the stem connector, or for size 87 actuators, the stem connector. Do not overtighten the locknuts.
6. Slowly decrease and then increase pressure several times stroking the valve from the lower bench set pressure to the upper pressure.

Be sure that the valve is in closed position (up or down, depending on valve action). Loosen the screws on the travel scale, and align it with the travel indicator disk or stem connector. Stroke the valve full travel to ensure that the travel matches the valve travel on the travel indicator plate. If valve travel is not correct, repeat the stem connector procedure.

Note

For push-down-to-close valves, the valve plug seat is the limit for downward travel and the actuator up-stop is the limit for upward (away from the valve) movement. For push-down-to-open valves, the actuator down stop is the limit for downward movement, and the valve seat is the limit for upward (away from the valve) movement.

Deadband Measurement

Deadband is caused by packing friction, unbalanced forces, and other factors in the control valve assembly. Deadband is the range a measured signal can vary without initiating a response from the actuator (see figure 5). Each actuator spring has a fixed spring rate (force). You have verified that the right spring was installed in the actuator by completing the Bench Set Spring Adjustment steps.

Deadband is one factor that affects the control valve assembly operation during automatic loop control. The control loop tolerance for deadband varies widely depending on the loop response. Some common symptoms of the deadband being too wide are no movement, a “jump” movement, or oscillating movements of the actuator during automatic loop control. The following steps are provided to determine the span of deadband. The percent of deadband is helpful in troubleshooting problems with the process control loop.

1. Start at a pressure near the lower bench set pressure, slowly increase pressure until the valve is approximately at mid-travel. Note this pressure reading.
2. Slowly decrease pressure until movement of the valve stem is detected, and note this pressure.
3. The difference between these two pressures is deadband, in psi.

657 Actuator (30-70 and 87)

4. Calculate the percent of deadband by:

$$\text{Deadband} = \frac{\text{Deadband, psi}}{\text{Bench Set Span, psi}} = \text{nn}\%$$

Loading Connection

The loading pressure connections are made at the factory if the valve, actuator, and positioner come as a unit. Keep the length of tubing or piping as short as possible to avoid transmission lag in the control signal. If a volume booster, valve positioner or other accessory is used, be sure that it is properly connected to the actuator. Refer to the positioner instruction manual or other manuals as necessary.

For actuators shipped separately or whenever the actuator pressure connections are installed, use the following steps:

1. Connect the loading pressure piping to the NPT female connection in the top of the diaphragm casing.
2. For sizes 70 and 87 actuators, if necessary, remove the 1/4 inch NPT bushing if a 1/2 inch NPT female connection is needed to increase connection size. The connection can be made with either piping or tubing.
3. Cycle the actuator several times to be sure that the valve stem travel is correct when the correct pressure ranges are applied to the diaphragm.



WARNING

If valve stem travel appears to be incorrect, refer to the Bench Set Spring Adjustment procedures at the beginning of this section. To avoid personal injury or product damage, do not place the valve into service if it is not reacting correctly to diaphragm loading pressure changes.

Maintenance

Actuator parts are subject to normal wear and must be inspected and replaced when necessary. The frequency of inspection and replacement depends on the severity of service conditions.



WARNING

Avoid personal injury or property damage from sudden release of process pressure or bursting of parts. Before performing any maintenance operations:

- **Always wear protective gloves, clothing, and eyewear when performing any maintenance operations to avoid personal injury.**
- **Disconnect any operating lines providing air pressure, electric power, or a control signal to the actuator. Be sure the actuator cannot suddenly open or close the valve.**
- **Use bypass valves or completely shut off the process to isolate the valve from process pressure. Relieve process pressure from both sides of the valve. Drain the process media from both sides of the valve.**
- **Vent the power actuator loading pressure and relieve any actuator spring precompression.**
- **Use lock-out procedures to be sure that the above measures stay in effect while you work on the equipment.**
- **The valve packing box may contain process fluids that are pressurized, even when the valve has been removed from the pipeline. Process fluids may spray out under pressure when removing the packing hardware or packing rings, or when loosening the packing box pipe plug.**
- **Check with your process or safety engineer for any additional measures that must be taken to protect against process media.**

Actuator Maintenance

This procedure describes how the actuator can be completely disassembled and assembled. When inspection or repairs are required, disassemble only those parts necessary to accomplish the job; then, start the assembly at the appropriate step.

Key numbers refer to figures 6, 7, or 8 unless otherwise indicated. Figure 6 shows the sizes 30 through 60 actuators, figure 7 illustrates the sizes 70 actuator, and figure 8 shows the size 87 actuator.

Actuator Disassembly

1. Bypass the control valve. Reduce the loading pressure to atmospheric, and remove the tubing or piping from the upper diaphragm casing (key 1).

WARNING

To avoid personal injury from the precompressed spring force thrusting the upper diaphragm casing (key 1) away from the actuator, relieve spring compression (step 2, below), and carefully remove casing cap screws (key 22) (step 4, below).

2. Thread the spring adjuster (key 12) out of the yoke (key 9) until all spring compression is relieved.
3. If required, remove the actuator from the valve body by separating the stem connector (key 26) and removing the yoke locknut or, for the size 87 actuator, the stud bolt nuts. Separate the stem connector by loosening the stem nuts (keys 15 and 16) and unscrewing the two cap screws.
4. Remove the diaphragm casing cap screws and nuts (keys 22 and 23), then lift off the upper diaphragm casing (key 1).
5. Remove the actuator diaphragm (key 2).
6. Remove the diaphragm plate, actuator stem, and cap screw (keys 4, 10 and 3) as an assembly. This assembly can be broken down further, if required, by removing the cap screw (key 3).
7. Remove the actuator spring (key 6) and the spring seat (key 11).
8. If required, remove the lower diaphragm casing (key 5) from the yoke (key 9) by loosening the cap screws (key 8) that hold it in place.
9. If required, remove the spring adjuster (key 12) by unscrewing it from the yoke (key 9).

Actuator Assembly

1. Coat the threads and the spring seat bearing surface of the spring adjuster (key 12) with lithium grease (key 241), and thread the spring adjuster into the yoke (key 9). Place the spring seat (key 11) in the yoke on the spring adjuster and turn the spring adjuster to ensure that threads are properly engaged.
2. Position the lower diaphragm casing (key 5) on the yoke (key 9), and fasten the parts together by

installing and evenly tightening the cap screws (key 8).

3. Set the actuator spring (key 6) squarely onto the spring seat (key 11).

4. If the diaphragm plate and actuator stem (keys 4 and 10) are separate, fasten them together using the cap screw and washer (keys 3 and 25). Coat the cap screw threads with lithium grease (key 241). Tighten the cap screw (key 3) to 41 N•m (30 lbf•ft) torque for size 30 actuators, 54 N•m (40 lbf•ft) torque for size 34 and 40 actuators, or 149 N•m (110 lbf•ft) torque for size 45 to 87 actuators. Slide the actuator stem and diaphragm plate (keys 10 and 4) into the yoke (key 9) so that the actuator spring (key 6) fits squarely between the diaphragm plate and the spring seat (key 11). Then slide the diaphragm rod through the spring adjuster (key 12).

5. Place the diaphragm (key 2) pattern-side up on the diaphragm plate (key 4). Align the holes in the diaphragm and the lower diaphragm casing (key 5).

6. Position the upper diaphragm casing (key 1) on the diaphragm (key 2) and align the holes.

Note

When you replace actuator diaphragms in the field, take care to ensure the diaphragm casing bolts are tightened to the proper load to prevent leakage, but not crush the material. Perform the following tightening sequence with a manual torque wrench for size 30-70 and 87 actuators.

CAUTION

Over-tightening the diaphragm casing cap screws and nuts (keys 22 and 23) can damage the diaphragm. Do not exceed 27 N•m (20 lbf•ft) torque.

Note

Do not use lubricant on these bolts and nuts. Fasteners must be clean and dry.

7. Insert the cap screws (key 22), and tighten the hex nuts (key 23) in the following manner. The first four hex nuts tightened should be diametrically opposed and 90 degrees apart. Tighten these four hex nuts to 13 N•m (10 lbf•ft).

657 Actuator (30-70 and 87)

8. Tighten the remaining hex nuts in a clockwise, criss-cross pattern to 13 N•m (10 lbf•ft).
9. Repeat this procedure by tightening four hex nuts, diametrically opposed and 90 degrees apart, to a torque of 27 N•m (20 lbf•ft).
10. Tighten the remaining hex nuts in a clockwise, criss-cross pattern to 27 N•m (20 lbf•ft).
11. After the last hex nut is tightened to 27 N•m (20 lbf•ft), all of the hex nuts should be tightened again to 27 N•m (20 lbf•ft) in a circular pattern around the bolt circle.
12. Once completed, no more tightening is recommended.
13. Mount the actuator on the valve by following the procedures in the Installation section.

Top-Mounted Handwheel Assembly

A top-mounted handwheel assembly (figures 9 and 10) is usually used as an adjustable casing-mounted up travel stop to limit full retraction of the actuator stem. Turning the handwheel clockwise moves the the handwheel stem (key 133, figures 9 and 10) down, compressing the spring.

Instructions are given below for complete disassembly and assembly of the top-mounted handwheel assembly. Perform the disassembly only as far as necessary to accomplish the required maintenance; then, begin the assembly at the appropriate step.

Key numbers refer to figure 9 (sizes 30 through 60) and figure 10 (sizes 70 and 87), unless otherwise indicated.

Disassembly for Top-Mounted Handwheel

1. Turn the handwheel (key 51) counter-clockwise so that the handwheel assembly is not causing any spring compression.
2. Bypass the control valve, reduce loading pressure to atmospheric, and remove the tubing or piping from the upper handjack body (key 142, figures 9 or 10).



WARNING

To avoid personal injury from the precompressed spring force thrusting the upper diaphragm casing (key 1) away from the actuator, thread the spring adjuster (key 12) out of the yoke until all spring compression is relieved, then carefully remove casing cap screws (key 22).

3. Remove the diaphragm casing cap screws and nuts (keys 22 and 23, figures 6, 7, or 8), and lift off the upper diaphragm casing and handwheel assembly.
 4. If necessary, the handwheel assembly can be separated from the diaphragm casing by removing the cap screws (key 141). This may be necessary to replace the O-ring (key 139), or for ease of handling.
 5. Loosen the travel stop locknut (key 137), and turn the handwheel (key 51) counter-clockwise. Remove the cotter pin and stop nut (keys 247 and 54), then lift off the handwheel.
 6. Unscrew the travel stop locknut (key 137) from the handwheel stem (key 133), and turn the stem out of the bottom of the body (key 142). A screwdriver slot is provided on the top of the stem for this purpose.
 7. Replace the O-ring (key 138) in the body (key 142).
 8. **For a handwheel assembly used on sizes 30 through 60 actuators**, complete the disassembly by driving out the groove pin (key 140, figure 9) and sliding the pusher plate (key 135, figure 9) off the stem.
- For a handwheel assembly used on a sizes 70 or 87 actuator**, complete the disassembly by unscrewing the retaining screw (key 174, figure 10) and removing the thrust bearing and pusher plate (keys 175 and 135, figure 10). Because the retaining screw (key 174) has left-hand threads, turn clockwise to loosen.

Assembly for Top-Mounted Handwheel

1. **For a handwheel assembly used on sizes 30 through 60 actuators**, coat the end of the handwheel stem (key 133, figure 9) with anti-seize lubricant (key 244). Slide the pusher plate (key 135, figure 9), onto the stem, and drive in the groove pin (key 140, figure 9) to lock the pieces together.

For a handwheel assembly used on a sizes 70 or 87 actuator, pack the thrust bearing (key 175,

figure 10) with anti-seize lubricant (key 244). Place the thrust bearing in the pusher plate (key 135, figure 10), slide the two parts onto the handwheel stem (key 133). Coat the retaining screw threads with thread locking sealant (key 242). Insert and tighten the retaining screw (key 174, figure 10).

2. Coat the O-ring (key 138) with lithium grease (key 241), and insert the O-ring in the body (key 142).

3. Coat the threads of the handwheel stem (key 133) with anti-seize lubricant (key 244). Screw the stem into the body (key 142).

4. Thread the travel stop locknut (key 137) onto the handwheel stem (key 133).

5. Place the handwheel (key 51), and the stop nut (key 54) on the handwheel stem (key 133). Tighten the hex nut to fasten the parts together. Secure the nut with the cotter pin (key 247).

6. If the body (key 142) was separated from the upper diaphragm casing (key 1, figures 6, 7, or 8), lubricate the O-ring (key 139) with lithium grease (key 241), and place the O-ring in the body. Align the holes in the diaphragm casing and the body, insert the cap screws (key 141), and tighten them evenly following a crisscross pattern to ensure a proper seal.

7. Position the upper diaphragm casing (key 1) on the diaphragm (key 2) and align the holes.

Note

When you replace actuator diaphragms in the field, take care to ensure the diaphragm casing bolts are tightened to the proper load to prevent leakage, but not crush the material. Perform the following tightening sequence with a manual torque wrench for size 30-70 and 87 actuators.

CAUTION

Over-tightening the diaphragm casing cap screws and nuts (keys 22 and 23) can damage the diaphragm. Do not exceed 27 N•m (20 lbf•ft) torque.

Note

Do not use lubricant on these bolts and nuts. Fasteners must be clean and dry.

8. Insert the cap screws (key 22), and tighten the hex nuts (key 23) in the following manner. The first four hex nuts tightened should be diametrically opposed and 90 degrees apart. Tighten these four hex nuts to 13 N•m (10 lbf•ft).

9. Tighten the remaining hex nuts in a clockwise, criss-cross pattern to 13 N•m (10 lbf•ft).

10. Repeat this procedure by tightening four hex nuts, diametrically opposed and 90 degrees apart, to a torque of 27 N•m (20 lbf•ft).

11. Tighten the remaining hex nuts in a clockwise, criss-cross pattern to 27 N•m (20 lbf•ft).

12. After the last hex nut is tightened to 27 N•m (20 lbf•ft), all of the hex nuts should be tightened again to 27 N•m (20 lbf•ft) in a circular pattern around the bolt circle.

13. Once completed, no more tightening is recommended.

14. Mount the actuator on the valve following the procedures in the Installation section.

Side-Mounted Handwheel for Sizes 34 through 60 Actuators

A side-mounted handwheel assembly (figures 11 and 12) is normally used as a manual actuator for sizes 34 through 60 actuators. Turning the handwheel counter-clockwise past the neutral position opens the valve. Two levers (key 146, figure 11) on a handwheel assembly operate the valve by moving the valve stem.

Instructions are given below for complete disassembly and assembly. Perform the disassembly only as far as necessary to accomplish the required maintenance; then begin the assembly at the appropriate step.

Disassembly for Side-Mounted Handwheel (Size 34-60)

1. If desired, the handwheel assembly can be removed from the actuator yoke. To do this, remove the hex nuts (keys 147 and 170) from the U-bolts (keys 166 and 143) that hold the assembly to the yoke.

657 Actuator (30-70 and 87)

2. Remove the retaining ring (key 154) and drive out the lever pivot pin (key 153).
3. Two screws (key 156) hold the right- and left-hand levers (key 146) together. Remove the screw from the top of the levers so that the levers will drop down out of the assembly. Disassemble further, if necessary, by removing the other screw.
4. Remove the screw (key 161) and pointer mounting bolt (key 159, not shown) located behind pointer (key 160).
5. Remove the stop nut (key 54), lockwasher (key 150), and washer (key 149). Then remove the handwheel (key 51), being careful not to lose the small ball (key 55) and spring (key 56).
6. Loosen the locking set screw (key 168, not shown). Then, using a suitable tool, unscrew the bearing retainer (key 136).
7. Pull the handwheel screw assembly (key 145) out of the handwheel body. The operating nut (key 132) will come out with the screw. Also remove the bushing (key 151).
8. If required, remove the two ball bearings (key 152), one from the bearing retainer and the other from the handwheel body.

Assembly for Side-Mounted Handwheel (Size 34-60)

1. Pack the ball bearings (key 152) with anti-seize lubricant (key 244). Insert one bearing and the bushing (key 151) into the handwheel body (key 142) as shown in figure 11 or 12. The bushing is not used in a handwheel assembly for sizes 45 through 60 actuators.
2. Coat the handwheel screw assembly (key 145) threads with anti-seize lubricant (key 244), and thread the operating nut (key 132) onto the screw. Slide the second ball bearing (key 152) onto the screw, and insert the end of the screw into either the bushing (key 151), as shown in figure 11, or into the bearing.
3. Thread the bearing retainer (key 136) into the body (key 142). Completely tighten the bearing retainer, and then loosen it one-quarter turn. Tighten the set screw (key 168, not shown) to hold the bearing retainer in place.
4. Coat the groove in the handwheel body (key 142) with lithium grease (key 241). Insert the spring (key 56) and ball (key 55) into the handwheel (key 51). Holding the ball and spring in the handwheel, put the handwheel, the washer (key 149), the lockwasher (key 150), and the stop

nut (key 54) onto the end of the handwheel screw (key 145). Tighten the stop nut.

5. Position the pointer mounting bolt (key 159, not shown) and pointer (key 160) as shown in figure 11 or 12. Insert and tighten the screw (key 161).
6. Assemble the two levers (key 146) with the cap screws (key 156) for handwheel assemblies for sizes 45, 50, and 60 actuators, or with the machine screws (key 156) for handwheel assemblies on sizes 34 and 40 actuators.
7. If the handwheel assembly was removed from the yoke (key 9, figures 6, 7, or 8), remount the handjack assembly to the yoke using the dowel pins for alignment. Position the U-bolts (keys 166 and 143) on the yoke, and hand-tighten the hex nuts (keys 170 and 147) to hold the handwheel assembly in position. Cap screws (key 163) should be tight against the yoke legs to provide stability. Tighten nuts (key 144). Finish tightening the U-bolt nuts to 163 N•m [120 lbf•ft] (key 170) and 41 N•m [30 lbf•ft] (key 147). Be sure the handwheel assembly remains flat against the mounting pad and perpendicular to the yoke.
8. Position the levers (key 146) as shown in figure 11 or 12. Insert the lever pivot pin (key 153), and snap the retaining ring (key 154) onto the lever pivot pin.

Side-Mounted Handwheel for Sizes 70 and 87 Actuators

A side-mounted handwheel assembly (figure 13) is normally used as a manual actuator for sizes 70 and 87 actuators. Turning the handwheel counter-clockwise past the neutral position opens the valve body. A pair of sleeves (keys 34 and 46, figure 13) operates the valve by moving the valve stem.

Instructions are given below for complete disassembly and assembly. Perform the disassembly only as far as necessary to accomplish the required maintenance; and then begin the assembly at the appropriate step.

Key numbers refer to figures 7 or 8, and 11.

Disassembly for Side-Mounted Handwheel (Size 70 & 87)

1. Bypass the control valve, reduce loading pressure to atmospheric, and remove the tubing or piping from the upper diaphragm casing (key 1).
2. Remove cover band (key 60), and relieve spring compression by turning the spring adjuster (key 12) counter-clockwise.

3. Remove the cap screws and casing screws and nuts (keys 22 and 23), lift off the upper diaphragm casing (key 1), and remove the diaphragm (key 2).
4. Remove the cap screw (key 3) and the washer (key 25), then take off the diaphragm plate (key 4).
5. Remove the actuator spring (key 6), the upper sleeve (key 34), and the spring seat (key 11) from the yoke cylinder. This exposes the needle bearing and races (keys 37 and 38).
6. Separate the halves of the stem connector assembly (key 26) by removing the two cap screws. Remove the actuator stem (key 10).
7. Remove the travel indicator (key 14).

CAUTION

To avoid possible product damage, do not move the neutral indicator scale after completing the following step.

8. Turn the handwheel to raise the lower sleeve (key 46) until it is free of the worm gear (key 44). Lift out the lower sleeve and the key (key 47). **DO NOT** move the neutral indicator scale (key 59).
9. Loosen two set screws (key 40), then unscrew the bearing retainer flange (key 39) and the attached spring adjuster (key 12), using a suitable tool in the open neck of the flange. Take out the gear and two needle bearings (key 42), one on each side of the gear.
10. Remove the spring adjuster (key 12) from the bearing retainer flange (key 39). If desired, the worm shaft (key 45) and associated parts can be disassembled to replace or lubricate them. To do so, first remove the stop nut (key 54) and the handwheel (key 51). Do not lose the small ball (key 55) and spring (key 56).
11. Loosen the two set screws (key 41), and unscrew the front and back retainers (keys 48 and 49). The ball bearings (key 50) will come out with the retainers. Remove the worm shaft (key 45).

Assembly for Side-Mounted Handwheel (Size 70 & 87)

1. The front and back retainers (keys 48 and 49) each have a slot in their threads for a set screw (key 41). Pack the ball bearings (key 50) with anti-seize lubricant (key 244), and insert one ball bearing into the back retainer (key 49) as shown in figure 13.

2. Thread the back retainer and ball bearing (keys 49 and 50) into the yoke (key 9). Align the slot in the bearing retainer with the set screw hole in the yoke, insert the set screw (key 41), and tighten it.
3. Coat the worm shaft (key 45) threads with anti-seize lubricant (key 244), and slide the shaft into the yoke so that the end of the shaft fits snugly into the back retainer (key 49).
4. Insert the bearing into the front retainer (key 48), and thread the retainer and ball bearing into the yoke (key 9). Align the slot in the retainer with the hole in the yoke, insert the set screw (key 41), and tighten it.
5. Put the spring and ball (keys 56 and 55) into the handwheel (key 51). Slide the handwheel onto the worm shaft (key 45). Thread the stop nut (key 54) onto the shaft.
6. Pack the two needle bearings (key 42) and coat the worm gear (key 44) threads with anti-seize lubricant (key 244). Insert the key (key 47), the bearings, and the gear into the yoke (key 9) as shown in figure 13.
7. Slots are cut into the threads of the bearing retainer flange (key 39). Thread the flange into the yoke (key 9) so that the slots and the holes for the set screws (key 40) align. Insert the screws, and tighten them.
8. The lower sleeve (key 46) has milled slots in one end. Coat the sleeve threads with lithium grease (key 241), then slide the end of the lower sleeve with the milled slots into the bearing retainer flange (key 39).
9. Turn the handwheel (key 51), and feed the sleeve through the gear so that the slot in the lower sleeve (key 46) engages the key (key 47) in the yoke (key 9). Continue turning the handwheel until the lower sleeve protrudes 93.7 mm (3.69 inches) below the surface of the yoke. The pin in the side of the lower sleeve should line up with the extension on the neutral indicator.
10. Slide the square end of the actuator stem (key 10) through the lower sleeve (key 46) so the stem contacts the valve stem. Clamp both stems in the two halves of the stem connector (key 26). The stem connector should not be closer than 3.2 mm (1/8 inches) to the lower sleeve when the actuator stem is in the retracted position. This adjustment will provide approximately 3.2 mm (1/8 inches) of free travel of the lower sleeve in either direction for manual operation. Fasten the stem connector halves together with the cap screws.

657 Actuator (30-70 and 87)

11. Pack the needle bearing and race (keys 37 and 38) with lithium grease (key 241), and slide the bearing onto the spring adjuster (key 12).
12. Put the spring seat and actuator spring (keys 11 and 6) into the yoke (key 9). Slide the upper sleeve (key 34) onto the actuator stem (key 10).
13. Put the diaphragm plate and washer (keys 4 and 25) onto the actuator stem (key 10). Insert and tighten the cap screw (key 3) to fasten the parts together.
14. Place the diaphragm (key 2) pattern-side up onto the diaphragm plate (key 4). Align the holes in the diaphragm and the lower diaphragm casing (key 5).
15. Position the upper diaphragm casing (key 1) onto the diaphragm (key 2) and align the holes.

Note

When you replace actuator diaphragms in the field, take care to ensure the diaphragm casing bolts are tightened to the proper load to prevent leakage, but not crush the material. Perform the following tightening sequence with a manual torque wrench for size 30-70 and 87 actuators.

CAUTION

Over-tightening the diaphragm casing cap screws and nuts (keys 22 and 23) can damage the diaphragm. Do not exceed 27 N•m (20 lbf•ft) torque.

Note

Do not use lubricant on these bolts and nuts. Fasteners must be clean and dry.

16. Insert the cap screws (key 22), and tighten the hex nuts (key 23) in the following manner. The first four hex nuts tightened should be diametrically opposed and 90 degrees apart. Tighten these four hex nuts to 13 N•m (10 lbf•ft).
17. Tighten the remaining hex nuts in a clockwise, criss-cross pattern to 13 N•m (10 lbf•ft).
18. Repeat this procedure by tightening four hex nuts, diametrically opposed and 90 degrees apart, to a torque of 27 N•m (20 lbf•ft).

19. Tighten the remaining hex nuts in a clockwise, criss-cross pattern to 27 N•m (20 lbf•ft).
20. After the last hex nut is tightened to 27 N•m (20 lbf•ft), all of the hex nuts should be tightened again to 27 N•m (20 lbf•ft) in a circular pattern around the bolt circle.
21. Once completed, no more tightening is recommended.
22. Mount the actuator onto the valve, following the procedures in the Installation section.
23. Return the actuator to service after completing the Loading Connection procedure in the Installation section and the procedures in the Adjustments section.

Casing-Mounted Adjustable Travel Stops

Note

If repeated or daily manual operation is expected, the actuator should be equipped with a manual top-mounted or side-mounted handwheel. Refer to the Top-Mounted Handwheel and Side-Mounted Handwheel sections of this instruction manual.

The casing-mounted adjustable up travel stop (figures 14 or 15) limits the actuator stroke in the upward direction. To adjust, first relieve actuator loading pressure before removing the travel stop cap (key 187, figure 14 or 15). Loosen the travel stop nut (key 137). Then turn the travel stop stem (key 133) clockwise into the diaphragm case to move the actuator stem downward (or counter-clockwise to move the stem upward). Finally, tighten the travel stop nut and replace the travel stop cap.

The adjustable down travel stop (figure 16) limits the actuator stroke in the downward direction. To adjust, first relieve actuator loading pressure before removing the travel stop cap (key 187). Then loosen the jam nut and adjust the stop nut (keys 189 and 54) either down on the stem to limit travel, or up on the stem to allow more travel. Lock the jam nut against the stop nut, then replace the closing cap.

Instructions are given below for disassembly and assembly. Perform the disassembly only as far as necessary to accomplish the required maintenance; then, begin the assembly at the appropriate step.

Key numbers are shown in figures 14, 15, and 16.

Disassembly for Casing-Mounted Travel Stop

1. Bypass the control valve. Reduce the loading pressure to atmospheric, and remove the tubing or piping from the connection in the body (key 142).



WARNING

To avoid personal injury from the precompressed spring force thrusting the upper diaphragm casing (key 1) away from the actuator, relieve spring compression (steps 2 and 3, below), and carefully remove casing cap screws (key 22) (step 4, below).

2. Thread the spring adjuster (key 12) out of the yoke (key 9) until all spring compression is relieved.

Casing-Mounted Adjustable Up Travel Stops

1. Remove the travel stop cap (key 187) and loosen the travel stop nut (key 137). Rotate the travel stop stem (key 133) counter-clockwise until the travel stop assembly is no longer compressing the spring.
2. Remove the upper diaphragm casing (key 1, figures 6, 7, or 8) as outlined in the Maintenance section.
3. Remove the cap screws (keys 141) and separate the travel stop assembly from the upper casing.
4. Remove and inspect the O-rings (keys 138 and 139); replace if necessary.
5. **For sizes 30 through 60**, drive out the groove pin (key 140), and slide the pusher plate (key 135) off the travel stop stem (key 133).

For sizes 70 and 87, remove the retaining screw (key 174) to inspect the thrust bearing (key 175).

Casing-Mounted Adjustable Down Travel Stops

1. Remove the travel stop cap (key 187). Unscrew the jam nut and stop nut (keys 189 and 54) until the travel stop assembly is no longer compressing the spring. Remove the jam nut and stop nut.
2. Remove the upper diaphragm casing (key 1, figures 6, 7, or 8) as outlined in the Maintenance section.
3. Remove the cap screws (keys 141) and separate the travel stop assembly from the upper casing.
4. Remove and inspect the O-ring (keys 139); replace if necessary.

5. Loosen the stop nut (key 54), then unscrew the travel stop stem (key 133) out of the actuator stem. The lower diaphragm plate can now be removed.

Assembly for Casing-Mounted Travel Stop

1. Reassemble the up or down travel stop in the reverse order of the disassembly steps, being sure to apply lubricant as shown by the lubrication boxes (key 241) in figures 6, 7, 8, 14, 15, or 16, as appropriate.
2. Readjust the travel stop to obtain the appropriate restriction by following the adjustment procedures presented in the introductory portion of the Casing-Mounted Adjustable Travel Stops section. Return the unit to operation.

Parts Ordering

Each actuator has a serial number stamped on the nameplate. Always mention this number when corresponding with your Emerson Process Management sales office regarding technical information or replacement parts. Also, reference the complete 11-character part number of each needed part as found in the following Parts List.



WARNING

Use only genuine Fisher® replacement parts. Components that are not supplied by Emerson Process Management should not, under any circumstances, be used in any Fisher valve, because they will void your warranty, might adversely affect the performance of the valve, and could give rise to personal injury and property damage.

Note

Neither Emerson, Emerson Process Management, nor any of their affiliated entities assumes responsibility for the selection, use and maintenance of any product. Responsibility for the selection, use, and maintenance of any product remains with the purchaser and end-user.

657 Actuator (30-70 and 87)

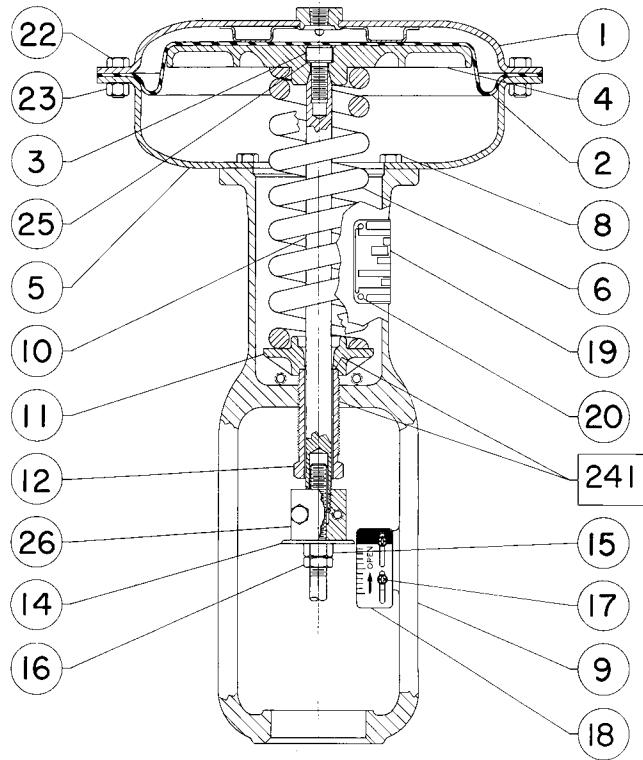

Figure 6. Type 657 Actuator Sizes 30 through 60

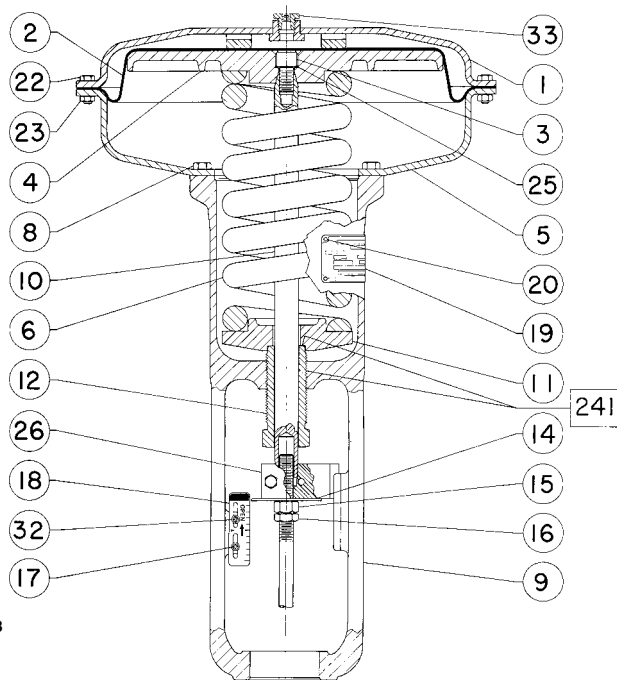

Figure 7. Type 657 Size 70 Actuator

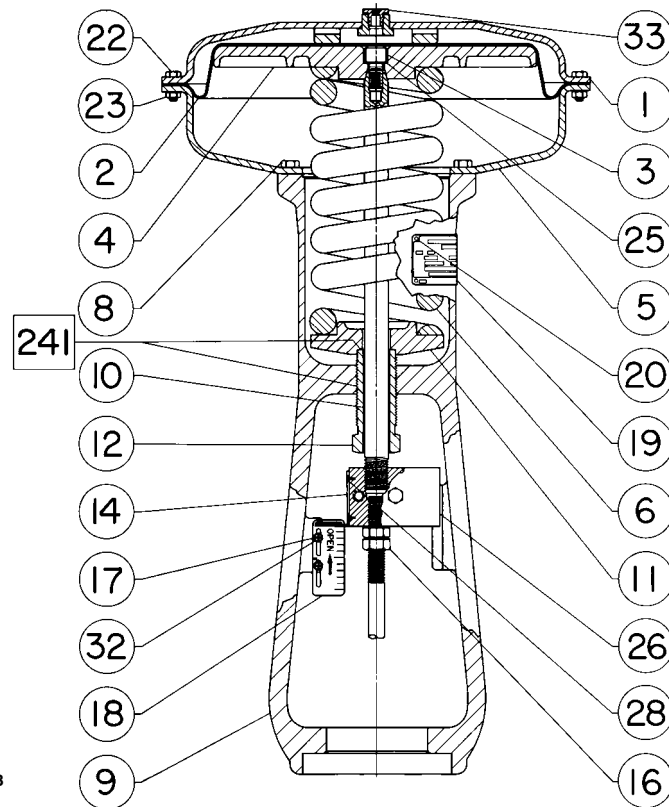

Figure 8. Type 657 Size 87 Actuator

Parts Kits

Key Description

Part Number

Note

Kits for Side-Mounted Handwheels

Retrofit kit includes parts to add a side-mounted handwheel.

Size 34 push down to close	30A8778X0A2
Size 34 push down to open	30A8778X0B2
Size 40 push down to close	30A8778X0C2
Size 40 push down to open	30A8778X0D2
Size 45 & 46 push down to close	40A8779X0A2
Size 40 & 60 push down to open	40A8779X0B2
Size 50 & 60 push down to close	40A8779X0C2
Size 50 & 60 push down to open	40A8779X0D2

Kits for Top-Mounted Handwheels

Retrofit kit includes parts to add a top-mounted handwheel. Kit 1 includes the handwheel assembly only. Kit 2 includes kit 1 and a new diaphragm case that is required to mount the handwheel assembly.

KIT 1

Size 30	28A1205X012
Sizes 34 & 40	28A1205X022
Sizes 45, 50, & 60	28A1205X032
Sizes 70 & 87	CV8010X0032

KIT 2

Size 30	28A1205X042
Sizes 34 & 40	28A1205X052
Sizes 45 & 50	28A1205X062
Sizes 46 & 60	28A1205X072
Sizes 70 & 87	CV8010X0042

Parts List

Part numbers are shown for recommended spares only. For part numbers not shown, contact your Emerson Process Management sales office.

Actuator Assembly (figures 6, 7, or 8)

Key	Description	Part Number
1	Upper Diaphragm Casing	
2*	Diaphragm	
	Molded nitrile/nylon	
	Standard construction	
	Size 30	2E791902202
	Sizes 34 & 40	2E670002202
	Sizes 45 & 50	2E859502202
	Sizes 46 & 60	2E859702202
	Sizes 70 & 87	2N126902202
	With down travel stop (style 2)	
	Size 30	2E800002202
	Sizes 34 & 40	2E669902202
	Sizes 45 & 50	2E859602202
	Sizes 46 & 60	2E859802202
	Sizes 70 & 87	2N130902202
	Molded silicone/polyester	
	Standard Construction	
	Size 30	18B2713X082
	Sizes 34 & 40	18B2713X092
	Sizes 45 & 50	18B2713X102

*Recommended spare parts

657 Actuator (30-70 and 87)

Key	Description	Part Number
	Sizes 46 & 60	18B2713X112
	Sizes 70 & 87	18B2713X122
	With down travel stop (style 2)	
	Sizes 70 & 87	2N1309X0012
	Fluorocarbon/Aramid	
	Size 30	1F354202402
	Sizes 34 & 40	1F444302402
	Sizes 45 & 50	1F354102402
	Sizes 46 & 60	1F4444X0022
3	Cap Screw	
4	Diaphragm Plate	
5	Lower Diaphragm Casing	
6	Actuator Spring	See following table
7	Travel Stop Cap Screw	
8	Cap Screw	
9	Yoke	
10	Actuator Stem	
11	Spring Seat	
12	Spring Adjuster	
13	Lower Diaphragm Plate	
14	Travel Indicator Disk, SST	
15	Stem Nut	
16	Stem Jam Nut	
17	Self-Tapping Screw	
18	Travel Indicator Scale	
19	Nameplate, SST	12B6508X0A2
20	Drive Screw	
22	Cap Screw	
23	Hex Nut	
24	Twin Speed Nut	
25	Washer	
26	Stem Connector Assy, Steel Zn Pl	
	Sizes 30 & 34	18A1243X012
	Size 34 with side mtd handwheel	1F659225142
	Size 40	18A1668X012
	Size 40 with side mtd handwheel	1F659125142
	Sizes 45 & 46	18A1671X012
	Sizes 45 & 46 w/ side mtd handwheel (SST,Stl)	2F1678000A2
	Sizes 50 & 60	18A1672X012
	Sizes 50 & 60 w/ side mtd handwheel (SST,Stl)	2F1672000A2
	Size 70	18A1685X012
	with side mtd handwheel	18A1678X012
	with PMV positioner	18A1845X012
	657-4 with 4 in. max. travel (SST,Stl)	21A8254X012
	Size 87 (SST,Stl)	21A7469X012
	Size 87 with side mtd handwheel	18A1825X012
28	Screw	
29	Yoke Extension	
30	Indicator Adaptor	
31	Machine Screw	
32	Washer	
33	Pipe Bushing	
61	Nameplate	
73	Cap Screw	
238	Warning label	
241	Lubricant, Lithium Grease (not furnished with the actuator)	
249	Caution nameplate	

Top Mounted Handwheel (figure 9 or 10)

Key	Description	Part Number
51	Handwheel	
54	Stop Nut	
133	Handwheel Stem, brass	
134	Washer	
135	Pusher Plate	
137	Casing-Mounted Travel Stop Locknut	
138*	O-Ring, nitrile	
	Sizes 30, 34, & 40	1D237506992
	Sizes 45, 46, 50, & 60	1B885506992
	Sizes 70 & 87	1C415706992
139*	O-Ring, nitrile	
	Sizes 30, 34, & 40	1D267306992
	Sizes 45, 46, 50, & 60	1D547106992
	Sizes 70 & 87	1D269106992
140	Groove Pin	
141	Cap Screw	
142	Body	
169	Grease Fitting	
174	Retaining Screw	
175	Thrust Bearing	
176	Thrust Race	
241	Lubricant, Lithium Grease (not furnished with actuator)	
242	Sealant, Thread-Locking (not furnished with handwheel)	
244	Lubricant, Anti-Seize (not furnished with handwheel)	
246	Spacer	
247	Cotter Pin	

Side-Mounted Handwheel (figure 11, 12, or 13)

34	Upper Sleeve
37	Needle Bearing
38	Needle Bearing Race
39	Bearing Retainer Flange
40	Set Screw
41	Set Screw
42	Needle Bearing
43	Needle Bearing Race
44	Worm Gear
45	Worm Shaft
46	Lower Sleeve
47	Key
48	Front Retainer
49	Back Retainer
50	Ball Bearing
51	Handwheel
52	Handgrip
53	Handgrip Bolt
54	Stop Nut
55	Ball
56	Spring
59	Handwheel Indicator
60	Cover Band Ass'y
61	Grease Fitting
132	Operating Nut
136	Bearing Retainer
142	Handwheel Body

Instruction Manual

Form 1900
February 2007

657 Actuator (30-70 and 87)

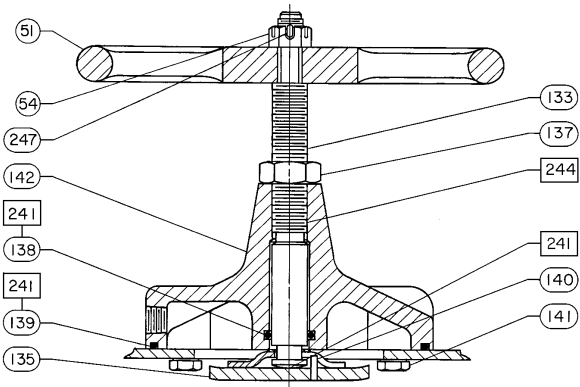

APPLY LUB/SEALANT

NOTES:
THE TOP MOUNTED HANDWHEEL IS NOT DESIGNED
FOR USE UNDER HEAVY LOAD OR FOR FREQUENT USE.

28A1205-D / IL

Figure 9. Top-Mounted Handwheel Assembly for Size 30 through 60 Actuators

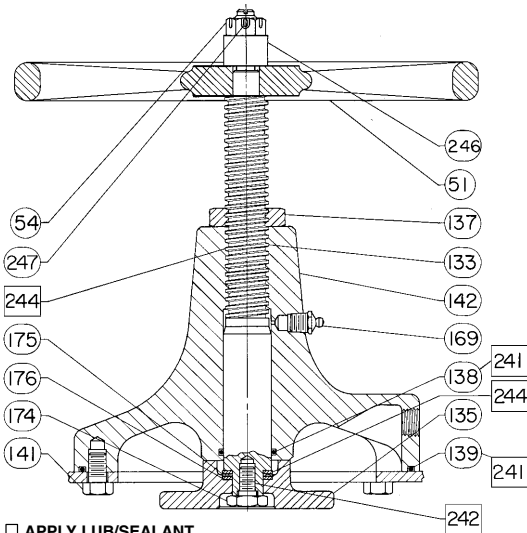

APPLY LUB/SEALANT

NOTES:
THE TOP MOUNTED HANDWHEEL IS NOT DESIGNED
FOR USE UNDER HEAVY LOAD OR FOR FREQUENT USE.

CV8010-G / IL

Figure 10. Top-Mounted Handwheel Assembly for Sizes 70 through 87 Actuators

Key	Description	Part Number
143	U-Bolt	
144	Hex Nut, pl steel	
145	Handwheel Screw	
146	Lever & Pin Ass'y	
147	Hex Jam Nut	
148	Dowel Pin	
149	Washer	
150	Lockwasher	
151	Bushing	
152	Ball Bearing	
153	Lever Pivot Pin	
154	Retaining Ring	
155	Lever Spacer	
156	Screw	
157	Lockwasher	
158	Hex Nut	
159	Pointer Mounting Bolt	
160	Pointer	
161	Screw	
162	Indicator Plate	
163	Cap Screw	
166	U-Bolt	
167	Guide Bolt	
168	Set Screw	
169	Grease Fitting	
170	Hex Nut	
177	Spring Cap	
178	Machine Screw	
241	Lubricant, Lithium Grease (not furnished with handwheel)	
244	Lubricant, Anti-Seize (not furnished with handwheel)	

657 Actuator (30-70 and 87)

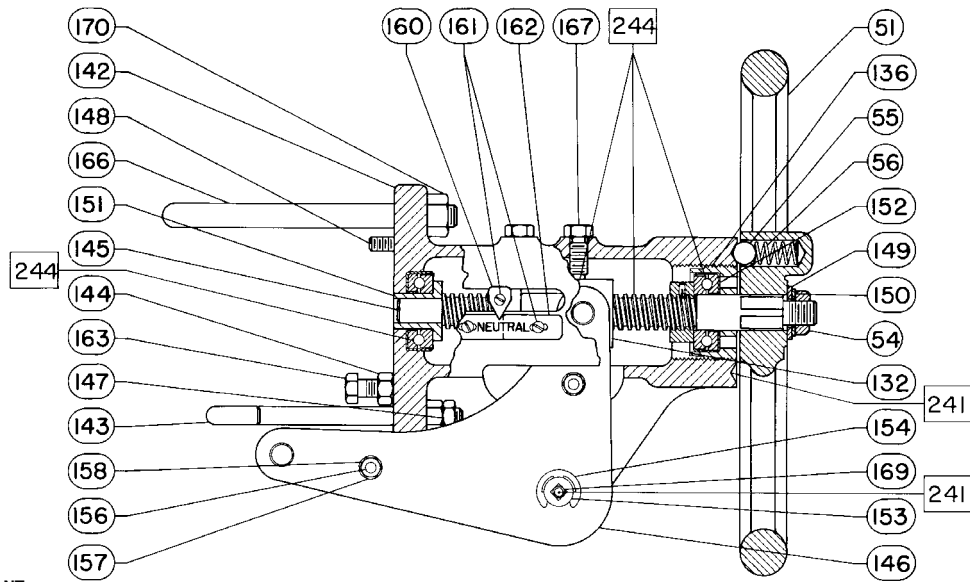

□ APPLY LUBRICANT
30A8778-D / IL

Figure 11. Side-Mounted Handwheel Assembly for Size 34 and 40 Actuators

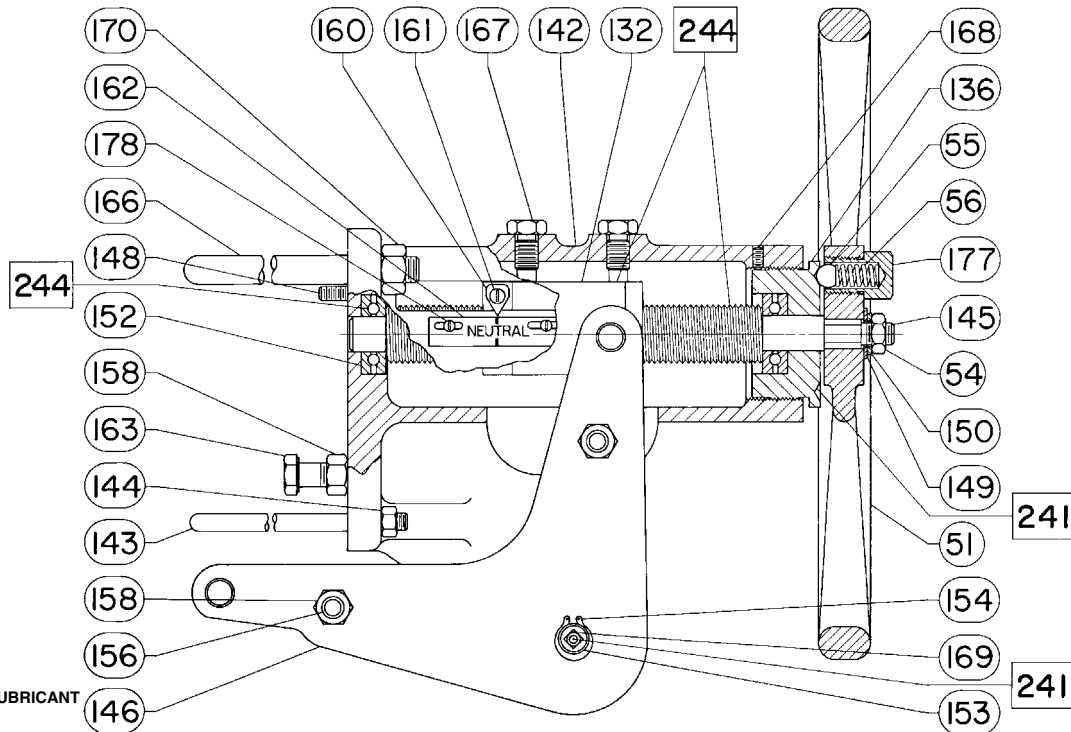

□ APPLY LUBRICANT
40A8779-D / IL

Figure 12. Side-Mounted Handwheel Assembly for Size 45 and 60 Actuators

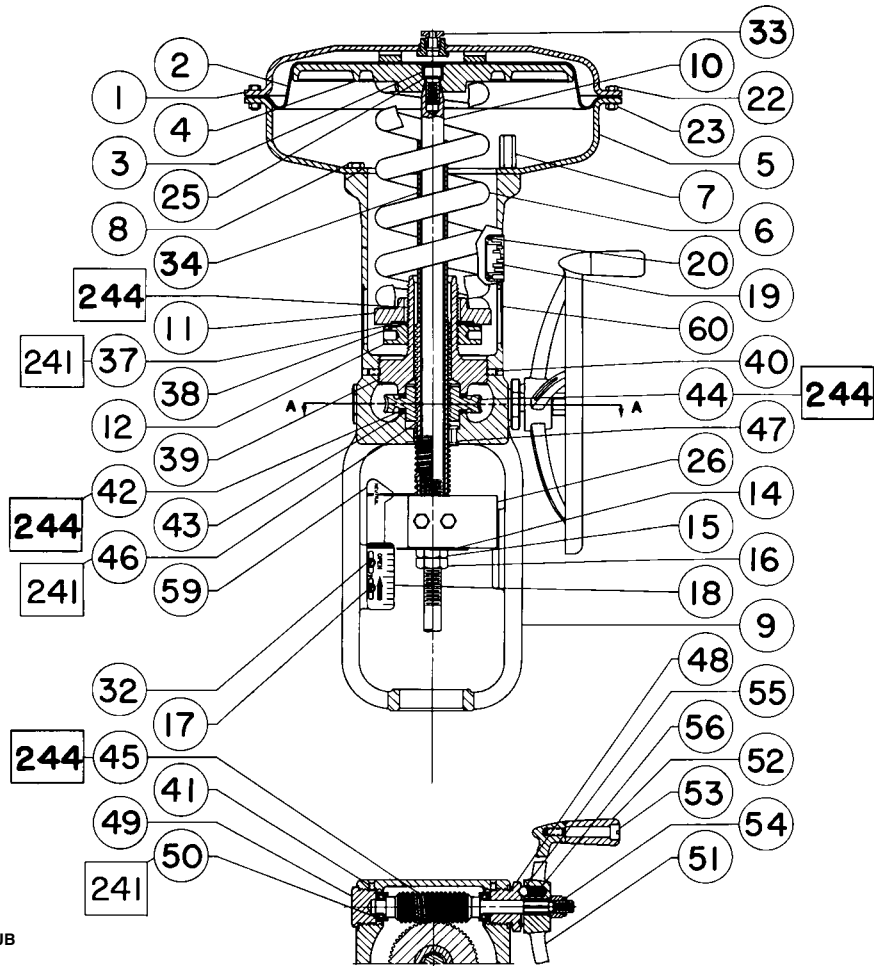

SECTION A-A

Figure 13. Type 657 Size 70 and 87 Actuators with Side-Mounted Handwheel

657 Actuator (30-70 and 87)

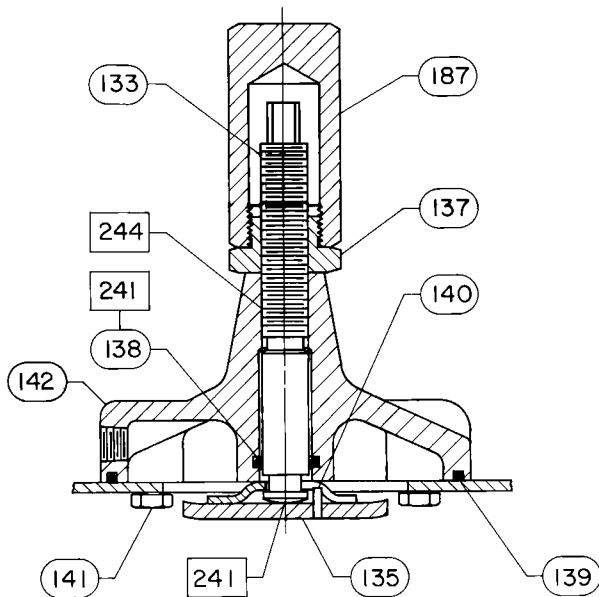

□ APPLY LUBRICANT
28A1206-C / IL

Figure 14. Casing-Mounted Adjustable Up Travel Stop for Sizes 30 through 60 Actuators (Style 1)

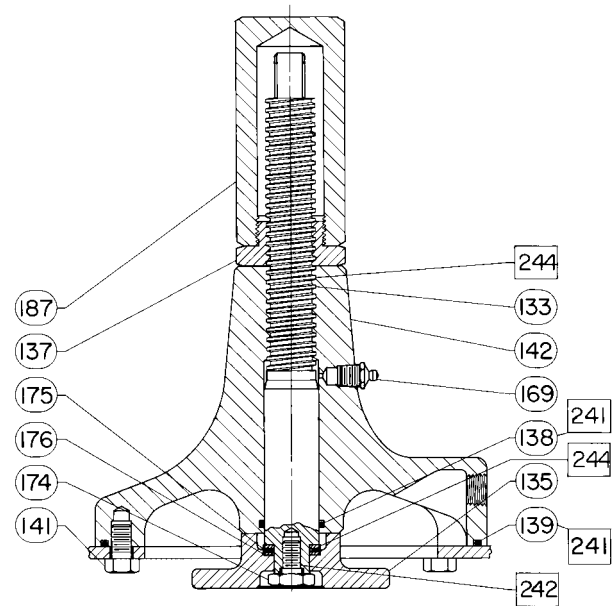

□ APPLY LUB/SEALANT
CV8057-E / IL

Figure 15. Casing-Mounted Adjustable Up Travel Stop for Sizes 70 and 87 Actuators (Style 1)

Key Description Part Number

Casing-Mounted Adjustable Up Travel Stops (figures 14 or 15)

Key	Description	Part Number
133	Travel Stop Stem	
135	Pusher Plate	
137	Travel Stop Nut	
138*	O-Ring, nitrile	
	Sizes 30, 34, & 40	1D237506992
	Sizes 45, 46, 50, & 60	1B885506992
	Sizes 70 & 87	1C415706992
139*	O-Ring, nitrile	
	Sizes 30, 34, & 40	1D267306992
	Sizes 45, 46, 50, & 60	1D547106992
	Sizes 70 & 87	1D269106992

Key Description Part Number

Key	Description	Part Number
140	Groove Pin	
141	Cap Screw	
142	Body	
169	Grease Fitting	
174	Retaining Screw	
175	Thrust Bearing	
176	Thrust Bearing Race	
187	Travel Stop Cap	
241	Lubricant, Lithium Grease (not furnished with travel stop)	
244	Lubricant, Anti-Seize (not furnished with handwheel)	

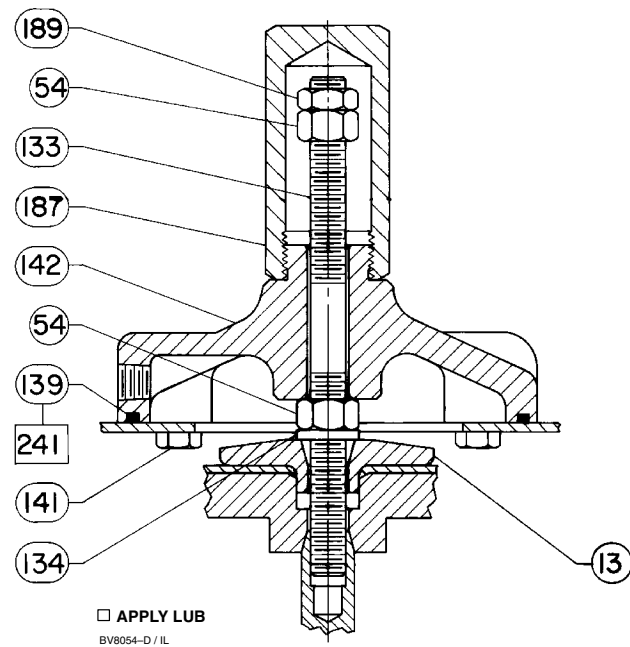

Figure 16. Casing-Mounted Adjustable Down Travel Stop for Size 30 and 40 Actuators (Style 2)

Key	Description	Part Number
-----	-------------	-------------

Casing-Mounted Adjustable Down Travel Stop (figure 16)

54	Stop Nut	
133	Travel Stop Stem	
134	Washer	
139*	O-Ring, nitrile	
	Sizes 30, 34, & 40	1D267306992
	Sizes 45, 46, 50, & 60	1D547106992
	Sizes 70 & 87	1D269106992
141	Cap Screw	
142	Body	
187	Travel Stop Cap	
189	Jam Nut	
241	Lubricant, Lithium Grease (not furnished with travel stop)	

657 Actuator (30-70 and 87)

Key 6 Actuator Spring

ACTUATOR SIZE	DIAPHRAGM PRESSURE RANGE		TRAVEL, mm (INCHES)					
	Bar	Psig	11 (0.4375)	16 (0.625)	19 (0.75)	29 (1.125)	38 (1.5)	51 (2)
30	0.2-1.0	3-15	1E795327082 Light Blue (1260)	1E795520792 Brown (885)	1E792327092 Dark Gray (735)	---	---	---
	0.4-2.0	6-30	1E795627082 White (2520)	1E795427082 Light Gray (1770)	1E79247082 Light Green (1470)	---	---	---
34 ⁽¹⁾ & 40	0.2-1.0	3-15	1E805127082 Aluminum (1840)	1E804927082 Yellow (1327)	1E805827082 White (1100)	1E805327092 Dark Gray (736)	1E805627092 Dark Green (550)	---
	0.4-2.0	6-30	1E805027082 Purple (3780)	1E804827082 Light Blue (2650)	1E805227082 Orange (2210)	1E805527082 Dark Blue (1470)	1E805827082 White (1100)	---
45 & 50	0.2-1.0	3-15	---	1E826727082 Tan (2080)	1E826227082 Light Green (1670)	1E826127082 Dark Gray (1120)	1E826627082 Orange (840)	1E826927082 Dark Green (630)
	0.4-2.0	6-30	---	1E825627082 Purple (4160)	1E825527082 Aluminum & Red (3320)	1E826427082 Light Gray (2240)	1E826227082 Light Green (1670)	1E826527082 Red (1260)
46 & 60	0.2-1.0	3-15	---	1E825827082 Yellow (2770)	1E825727082 Brown (2500)	1E826227082 Light Green (1670)	1E826527082 Red (1260)	1E827027082 Aluminum & Dark Blue (935)
	0.4-2.0	6-30	---	---	1E826027082 Bronze (5000)	1E825527082 Aluminum & Red (3320)	1E825720782 Brown (2500)	1E826327082 Aluminum & Dark Green (1870)
			19 (0.75)	29 (1.125)	38 (1.5)	51 (2)	76 (3)	102 (4)
70 & 87	0.2-1.0	3-15	1N127927082 Red (3360)	1N719327082 White (2240)	1N128727082 Yellow (1680)	1N128427082 Light Green (1260)	1N128627082 Dark Gray (840)	---
	0.4-2.0	6-30	---	1N128127082 Brown (4475)	1N127927082 Red (3360)	1N128527082 Light Blue (2520)	1N128727082 Yellow (1680)	1R676027082 ⁽²⁾ Black (860)

1. 29 mm (1.125 inch) and 38 mm (1.5 inch) travels available in size 40 only.
 2. Diaphragm pressure range for this spring & travel combination is 0.2-2.0 bar (3-30 psig).

easy-e and Fisher are marks owned by Fisher Controls International LLC, a member of the Emerson Process Management business division of Emerson Electric Co. Emerson Process Management, Emerson, and the Emerson logo are trademarks and service marks of Emerson Electric Co. All other marks are the property of their respective owners.

The contents of this publication are presented for informational purposes only, and while every effort has been made to ensure their accuracy, they are not to be construed as warranties or guarantees, express or implied, regarding the products or services described herein or their use or applicability. We reserve the right to modify or improve the designs or specifications of such products at any time without notice.

Neither Emerson, Emerson Process Management, nor any of their affiliated entities assumes responsibility for the selection, use and maintenance of any product. Responsibility for the selection, use and maintenance of any product remains with the purchaser and end-user.

Emerson Process Management

Marshalltown, Iowa 50158 USA
 Cernay 68700 France
 Sao Paulo 05424 Brazil
 Singapore 128461

www.Fisher.com

