



**ORION™**

HIGH PERFORMANCE CAR AUDIO

*owner's manual*

**MaxxBass®**

**POWERED BY HARDCORE ATTITUDE**

## TABLE OF CONTENTS

Congratulations .....	2
Service .....	2
Caution .....	2
Why Use <b>MaxxBass</b> <sup>®</sup> .....	2
Why is <b>MaxxBass</b> <sup>®</sup> Better .....	3
What is <b>MaxxBass</b> <sup>®</sup> .....	3
How does <b>MaxxBass</b> <sup>®</sup> Work .....	4
<b>MaxxBass</b> <sup>®</sup> Signal Flow .....	5
Features .....	5
Specifications .....	6
Installation/Mounting .....	6
<b>MaxxBass</b> <sup>®</sup> Outline and Dimensions .....	7
Wiring Configurations .....	8
Wiring Procedures .....	9
Input .....	11
<b>MaxxBass</b> <sup>®</sup> Processor Settings .....	12
Troubleshooting .....	13

## CONGRATULATIONS

Thank you for choosing **Orion** audio equipment. At **Orion** we proudly design, engineer and manufacture audio products for aftermarket car audio. Our award winning engineering team utilizes innovative technology to consistently deliver Absolutely State of the Art performance, sound quality, reliability, and value. This **Orion** product reflects our commitment to offer you unparalleled versatility and quality for years of dependable service and listening enjoyment.

## SERVICE

Do not attempt to service **Orion** products yourself. Performing exploratory surgery on your audio equipment yourself will void the warranty. Many parts of your **Orion** gear are custom built to our specifications. Our factory parts are not made available to anyone else nor are they for sale. Our goal is to make sure that your **Orion** will always sound as good as the day it was purchased. Contact your authorized **Orion** dealer about obtaining any warranty service through **Orion**. (See Warranty on back cover).

(Record listing for Model, Serial Number, and Purchase Date)

Model \_\_\_\_\_  
Serial Number \_\_\_\_\_  
Purchase Date \_\_\_\_\_

## CAUTION

The extended use of a high-powered audio system may result in hearing loss or damage. While **Orion** systems are capable of "Concert Level" volumes with incredible accuracy, they are also designed for you to enjoy more reasonable levels all of the sonic subtleties created by musicians. Please observe all local sound ordinances.

## WHY USE **MAXXBASS**®

**Orion** will introduce the first **MaxxBass**® processor to the automotive market. The **MaxxBass**® processor is ideal for improving the perceived bass response in door mounted speakers without upgrading the speakers or amplifiers.

**MaxxBass**® provides subwoofer like performance with perceived bass response to 30-40Hz on door mounted speakers. The **MaxxBass**® Processor is

recommended in two configurations. (Please see Wiring Configurations for more details.)

#### 1) Front Stereo Configuration

One *MaxxBass*<sup>®</sup> Processor is used between the front channel source and front speaker amplifier to increase the bass response on only the front speakers. This is recommended to improve bass imaging in high performance systems with rear mounted subwoofers.

#### 2) Dual Stereo Configurations

For systems without rear subwoofers, the user may prefer to use two *MaxxBass*<sup>®</sup> Processors, one for the front speakers and one for the rear speakers. Although not nearly as good bass performance as using a high performance subwoofer, this configuration will provide close to subwoofer like performance without the space requirements of a high performance subwoofer. This is a practical alternative for bass performance where a subwoofer system can not be added.

### WHY IS *MAXXBASS*<sup>®</sup> BETTER

*MaxxBass*<sup>®</sup> is NOT a bass boost technology. Bass boost technologies try to compensate for lack of bass frequency range by equalizing or increasing the relative volume of the frequencies near the speaker limit.

- This increases amplifier and speaker excursion limits, which can damage the system at high levels.
- This destroys the intended frequency balance of music.

*MaxxBass* uses psychoacoustics to extend the perceived bass frequency response.

- It is proven to provide up to 1.5 octaves of increased bass range.
- It does not change the frequency balance of the music and sounds more natural than large bass boosts.
  - It does not require more amplifier power and speaker excursion.
  - It has been proven over many years of use in professional audio recording.

### WHAT IS *MAXXBASS*<sup>®</sup>

*MaxxBass*<sup>®</sup> is a patented technology, which extends the bass frequency range by allowing listeners to perceive bass frequencies more than an octave below the physical limitations of speakers systems. In cars *MaxxBass*<sup>®</sup> allows door mounted speakers that typically drop off below 70-100Hz to play down another octave or more.

This is accomplished using the science of psychoacoustics on how we perceive sound. By building audio systems optimized for how we hear sound, significant performance improvements can be obtained. This is analogous to designing and building televisions that only display red, green and blue dots. When we view these displays our visual perception combines these dots to make a full color spectrum without needing to reproduce all the necessary color frequencies.

Unlike other bass technologies *MaxxBass*<sup>®</sup> delivers more perceived bass while simultaneously reducing the likelihood of damaging speakers and amplifiers. *MaxxBass*<sup>®</sup> also delivers this extended bass without any perceived distortion. *MaxxBass*<sup>®</sup> technology has been used for years in mastering most of the world's most popular music.

## HOW DOES *MAXXBASS*<sup>®</sup> WORK

*MaxxBass*<sup>®</sup> uses advanced digital signal processing based on the proven psychoacoustic Phenomenon of the Missing Fundamental. A basic description and a *MaxxBass*<sup>®</sup> Signal Flow diagram are provided for interested users.

*MaxxBass*<sup>®</sup> first implements a crossover at the *MaxxBass*<sup>®</sup> Frequency. The *MaxxBass*<sup>®</sup> Processor allows the choice of 60Hz, generally suggested for 6-6.5" drivers, and 80Hz suggested for 4-5.25" woofer drivers.

The low pass filter (LPF) output of the crossover extracts the bass signal which is below the bass frequency response of the system. This is the signal to be reproduced psycho-acoustically and only this signal receives the *MaxxBass*<sup>®</sup> processing. It is significant to note that unlike bass boosts, *MaxxBass*<sup>®</sup> does not add or change the processing of higher frequencies that can be reproduced by the system. *MaxxBass*<sup>®</sup> does not change the artist's sound mix.

*MaxxBass*<sup>®</sup> uses a patented digital signal processing algorithm to calculate precise harmonic content information which is added back into the LPF signal. The combined LPF and harmonics output is high pass filtered, thus removing the original bass signal. The processed signal is then added back into the original HPF signal and the final output provides a signal that sounds like the original, but no longer has un-reproducible low frequencies.

## MAXXBASS® SIGNAL FLOW

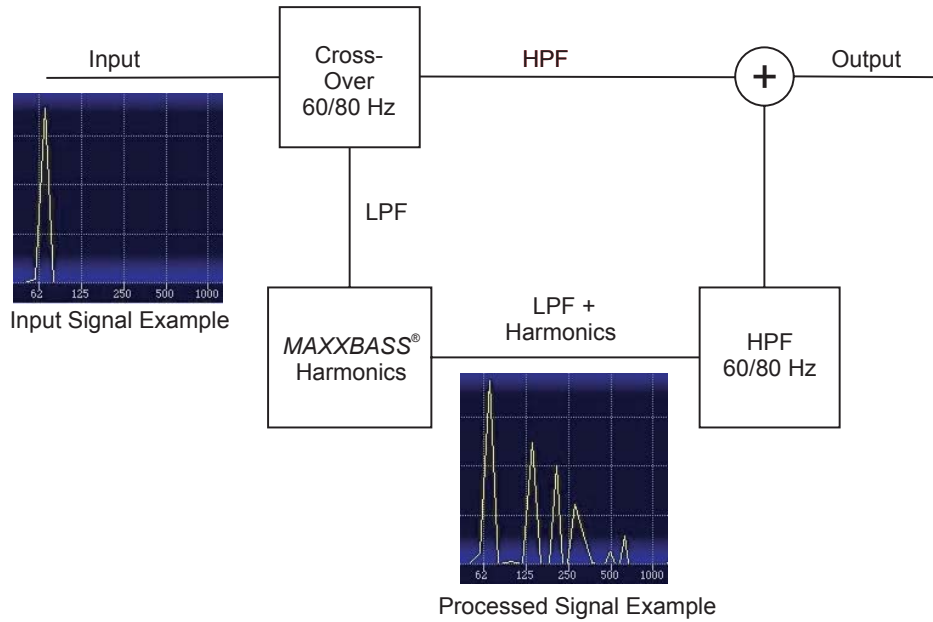

## FEATURES

- Selectable *MaxxBass*® Frequency Setting of 60Hz and 80Hz
- Green LED clip/Red LED power indicator signal
- Gold 2 Channel in/2 channel buffered full-range out RCA connectors
- 4-pin locking power plug
- Input connector for outboard *MaxxBass*® Intensity controller
- Remote and on-box intensity controls
- Intensity adjustment from 0 to full effect
- -18dB/octave high pass filter output at 60/80Hz
- Defeatable -24/dB octave low pass filter at 100Hz on the input

## SPECIFICATIONS

Frequency	20hz-20kHz
Signal-to-Noise Ratio	>85dB
Separation	65dB @ 1kHz
Crossover Slope	24dB/octave
Input Impedance	20,000 Ohms
Input Sensitivity	variable, 300mV to 3V peak to peak
Output Level	variable, 300mV to 5V peak to peak
Supply Voltage	9 to 16 VDC

## INSTALLATION/MOUNTING

**NOTE:** As an option, before beginning, disconnect the negative (-) terminal of the battery to prevent an electrical short to ground. Reconnect the negative terminal only after all connections have been made.

To prevent damage to the *MaxxBass*<sup>®</sup> Processor while driving, mount in a secure place. Choosing the appropriate location will depend upon your vehicle and the complexity of your system design. Typical mounting locations include the trunk and passenger compartment (floor or under seat). Never mount the *MaxxBass*<sup>®</sup> Processor in a location that would subject it to immersion or exposure to water.

Once a location has been chosen, securely mount the *MaxxBass*<sup>®</sup> Processor with the four mounting screws. Be Careful! Inspect the area underneath to be sure you are not drilling into wires, brake or fuel lines, etc. that could be damaged by the drill bits or screws.

# MAXXBASS® OUTLINE AND DIMENSIONS

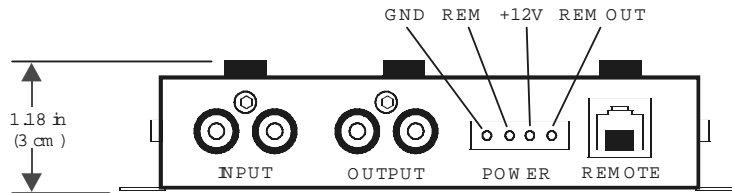
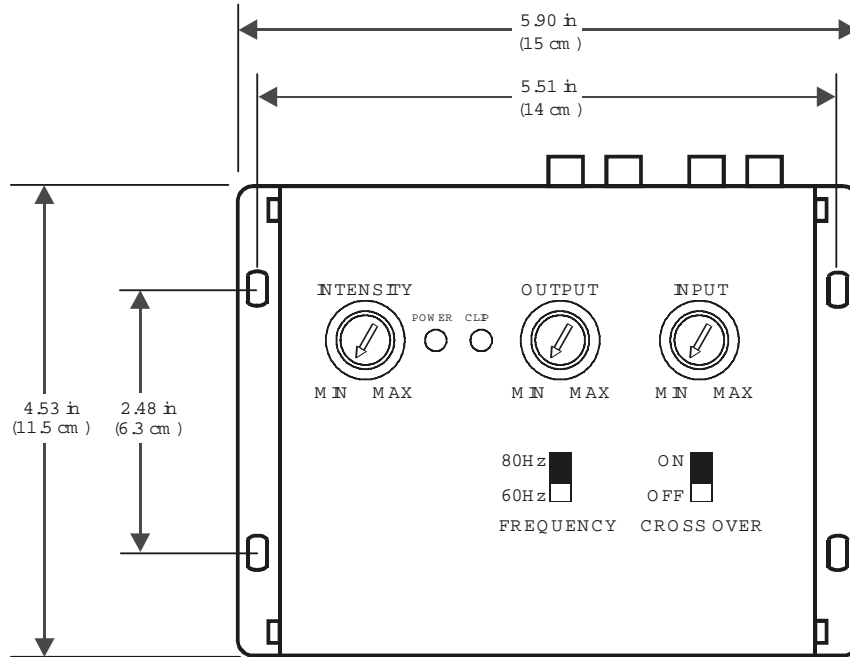



## WIRING CONFIGURATIONS

The *MaxxBass*® Processor is recommended in two different configurations.

### 1. Front Stereo Configuration

The figure below illustrates the wiring for a front stereo configuration. One *MaxxBass*® Processor is used between the front channel source and front speaker amplifier to increase the bass response only on the front speakers.

Implementing *MaxxBass*® on the front speakers will increase the perceived bass response of these speakers down to 30-40Hz providing a Virtual Subwoofer. The listener will achieve better bass balance and imaging with a rear mounted subwoofer or trunk mounted speakers with sufficient bass response.

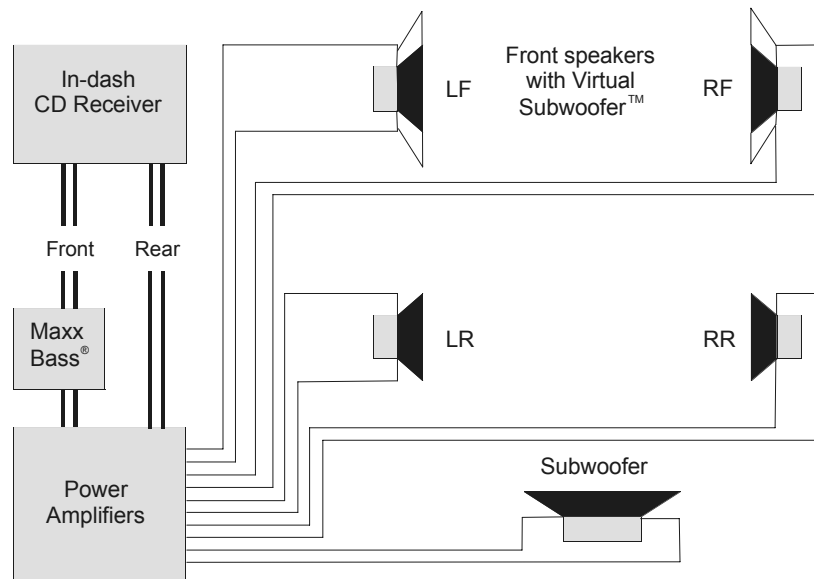

## 2. Dual Stereo Configurations

For systems without rear subwoofers, the user may prefer to use two *MaxxBass*<sup>®</sup> Processors, one for the front speakers and one for the rear speakers. The units should be wired between the in-dash CD Receiver and the power amplifiers as shown below.

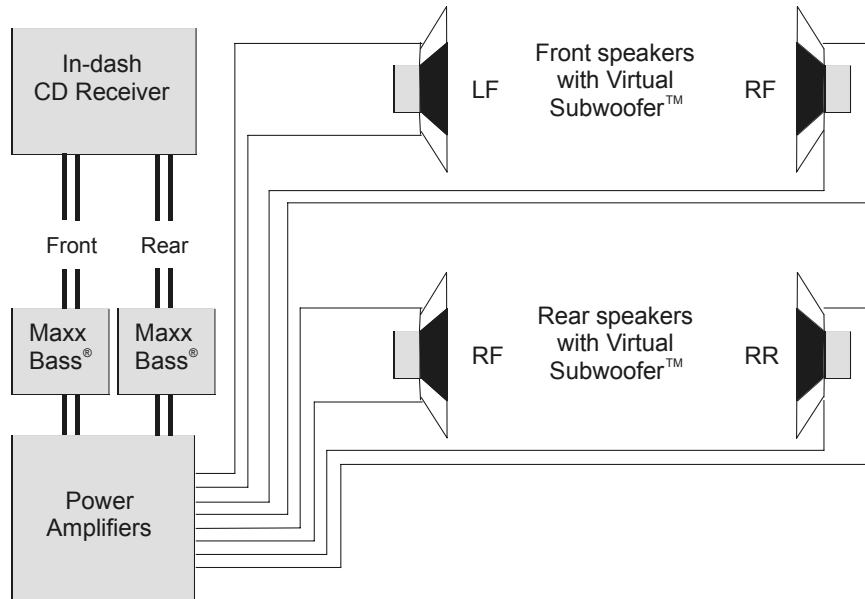

**NOTE:** As an option, before beginning, disconnect the negative (-) terminal of the battery to prevent an electrical short to ground. Reconnect the negative terminal only after all connections have been made.

## WIRING PROCEDURES

The next step is to connect the Power, Ground, and Remote IN/OUT wires to your *MaxxBass*<sup>®</sup> Processor. The power wire should run from the mounting location through the vehicle to the battery or power distribution block. Avoid sharp corners, creases, and sharp body parts. When passing through any metal wall (i.e. firewall, etc.), a grommet must be used to prevent the wire from chafing and shorting to ground.

The ground wire should be of the same gauge wire as the power wire. As a rule of thumb, use as short length of wire as possible. Find a location near the *MaxxBass*<sup>®</sup> Processor that is metal ( the floor is ideal) and clean an area about the size of a quarter to bare metal. Drill a pilot hole in the middle of this area. Terminate the wire with a ring connector and attach it to the bare metal using a #8 sheet metal screw and washer (not supplied). We suggest crimping and/or soldering this connection. After the connection is complete, coat the area with silicone or some similar material to prevent rust from developing.

Finally, the remote IN wire needs to connect to the "Amplifier Remote" lead of the head unit. This wire supplies a 12 volt signal to the *MaxxBass*<sup>®</sup> Processor when the main System is activated. The remote OUT wire is to be connected to the remote input of the source amplifier or to and "optional" relay to activate multiple amplifiers. Once you have routed the power, ground, and remote wires through the vehicle, it is time to connect the wires to the *MaxxBass*<sup>®</sup> Processor. Be sure that you have not reconnected the ground cable to the negative post of the battery.

**NOTE:** Refer to the diagram of the system shown in *MaxxBass*<sup>®</sup> Outline and Dimensions for connection points.

Cut off the excess wire and, using the wire strippers, strip the power, ground and remote cables about 1/8 inch. Locate the power, ground, and remote IN/OUT wires of the power plug (supplied). We again, suggest crimping and or soldering each connection separately to insure no damage to the unit or the audio system. Check that each connection is tight. If the wires are secure, the plug may be inserted into the *MaxxBass*<sup>®</sup> Processor.

## INPUT

To use Speaker Level Inputs (common ground head units only), connect RCA plugs to the front or rear speaker leads as shown.

**NOTE:** It is important to connect an input signal to both RCA input jacks if a stereo amplifier is used, otherwise the connected channel receives full range and the disconnected channel will receive only the harmonics. Use a RCA female to dual male "Y" cord if mono input is used.

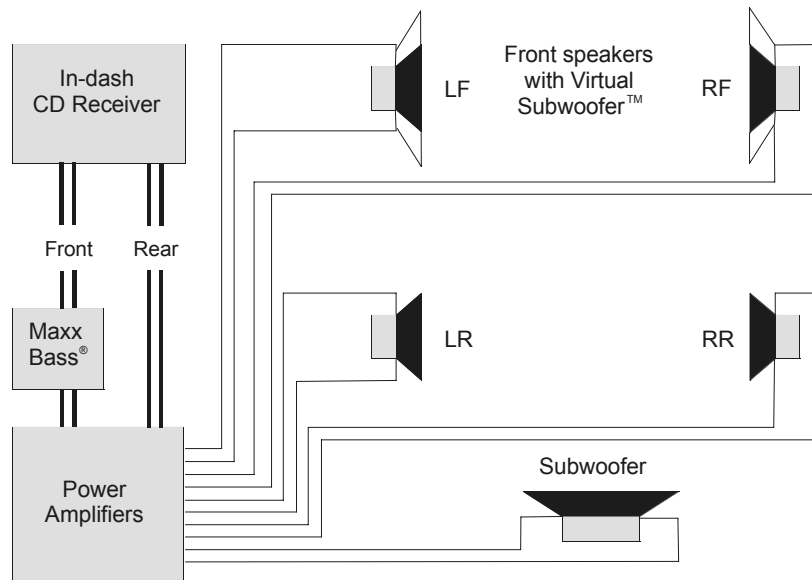

**WARNING:** If you are using a source unit with bridged high powered (or "floating ground") speaker outputs, a suitable high to low level adapter must be used. If you are unsure about your head unit see your local **Orion** dealer.

## MAXXBASS® PROCESSOR SETTINGS

To achieve proper performance it is important to set or tune the settings on the *MaxxBass*® Processor to the final system. This section recommends initial settings and the users can then further adjust these for optimal listening.

**1. CROSSOVER:** The CROSSOVER control implements a -24dB/octave low pass filter on the input. Set the CROSSOVER control to OFF if the amplifier and speakers after the *MaxxBass*® Processor are full range speakers or if passive crossovers are used in the speakers. Set the CROSSOVER control to ON, if the *MaxxBass*® Processor is only used on a woofer channel and separate amplifiers and speakers are provided for tweeters.

**2. FREQUENCY:** The FREQUENCY control should be set to 60Hz for 6.5 inch door speakers and 80Hz for 5.25 to 4.0 inch door speakers.

**3. INPUT:** The INPUT control is a signal attenuator for high voltage inputs. The CLIP LED can be used to help set the maximum input level setting prior to clipping. Start with INPUT control near MIN position and increase INPUT level until the Clip LED lights occasionally.

**4. OUTPUT:** The OUTPUT control provides a linear gain on the output to help match signal levels to power amplifiers. Start with OUTPUT control near MIN position and adjust accordingly to match levels with other system components.

**5. INTENSITY:** The INTENSITY control provides an input to the *MaxxBass*® algorithm on the level of the effect. Start with INTENSITY near MIN position and increase until the desired level of bass effect is obtained.

The INTENSITY control on the *MaxxBass*® Processor and Remote Unit have identical functionality. At the MIN position on the INTENSITY control, the *MaxxBass*® algorithm is in bypass, so that no *MaxxBass*® processing occurs.

When the Remote INTENSITY control is plugged into the *MaxxBass*® Processor, the Remote INTENSITY control become active and the INTENSITY control on the *MaxxBass*® Processor is disabled. This allows the user to install a remote control in a location different than the *MaxxBass*® Processor and place in a more convenient position for the listener such as underneath the dashboard or in the glove compartment.

The INTENSITY control on the *MaxxBass*® Processor system is only active when the Remote INTENSITY control is not plugged in. This control is provided for users, who do not wish to use the Remote INTENSITY control.

## TROUBLESHOOTING

### **NO SOUND**

Is the POWER LED lit?

#### **YES**

Check Input cables for signal by Connecting them straight to the Subwoofer amplifier.

#### **NO**

Check power and remote turn-on wire for voltage. Make sure the ground wire is Secure.

ANY SOUND NOW?

#### **YES**

Problem is in the Crossover. See your local Authorized **Orion** Dealer.

#### **NO**

Problem is elsewhere in the system. Check head Unit and amplifiers.

### **SOUND IN ONE CHANNEL ONLY**

Reverse left and right RCA outputs for one band (i.e.-subwoofers)

SOUND IS NOW IN

#### **OPPOSITE CHANNEL**

Reverse RCA inputs

#### **SAME CHANNEL**

Problem is in the amplifier, Speakers, or associated wiring of the silent channel.

SOUND IS NOW IN

**OPPOSITE CHANNEL**

Reverse RCAs to head unit  
(Check Balance Control)

**SAME CHANNEL**

Problem is in the Crossover.  
See your local Authorized  
**Orion** dealer.

SOUND IS NOW IN

**OPPOSITE CHANNEL**

Problem is in the head unit.

**SAME CHANNEL**

Problem is in the RCA cables.

**LOW OUTPUT FROM ONE BAND**

Check crossover frequencies and check gain control on the effected amplifier(s).

STILL LOW OUTPUT - See your local Authorized **Orion** dealer.





# Warranty

## LIMITED TWO YEAR CONSUMER WARRANTY:

Directed Electronics, Inc. promises to the original purchaser, to replace this product should it prove to be defective in workmanship or material under normal use, for a period of two years from the date of purchase by the dealer as indicated by the date code marking of the product **PROVIDED** the product was installed by an authorized Directed dealer. During this two year period, there will be no charge for this replacement **PROVIDED** the unit is returned to Directed, shipping pre-paid. If the unit is installed by anyone other than an authorized Directed dealer, the warranty period will be 1 year from date of purchase by the dealer as indicated by the date code marking of the product. During this 1 year period, there will be no charge for this replacement **PROVIDED** the unit is returned to Directed, shipping pre-paid. This warranty is non-transferable and does not apply to any unit that has been modified or used in a manner contrary to its intended purpose, and does not cover damage to the unit caused by installation or removal of the unit. This warranty is void if the product has been damaged by accident or unreasonable use, neglect, improper service or other causes not arising out of defects in materials or construction. **ALL WARRANTIES INCLUDING BUT NOT LIMITED TO EXPRESS WARRANTY, IMPLIED WARRANTY, WARRANTY OF MERCHANTABILITY, FITNESS FOR PARTICULAR PURPOSE, AND WARRANTY OF NON-INFRINGEMENT OF INTELLECTUAL PROPERTY ARE EXPRESSLY EXCLUDED TO THE MAXIMUM EXTENT ALLOWED BY LAW, AND DIRECTED NEITHER ASSUMES NOR AUTHORIZES ANY PERSON TO ASSUME FOR IT ANY LIABILITY IN CONNECTION WITH THE SALE OF THE PRODUCT. DIRECTED HAS ABSOLUTELY NO LIABILITY FOR ANY AND ALL ACTS OF THIRD PARTIES INCLUDING ITS AUTHORIZED DEALERS OR INSTALLERS.** Unit must be returned to Directed, postage pre-paid, with: consumer's name, telephone number, and address, authorized dealer's name and address, and product description. **IN ORDER FOR THIS WARRANTY TO BE VALID, YOUR UNIT MUST BE SHIPPED WITH PROOF OF INSTALLATION BY AN AUTHORIZED DIRECTED DEALER. ALL UNITS RECEIVED BY DIRECTED FOR WARRANTY REPAIR WITHOUT PROOF OF DIRECTED DEALER INSTALLATION WILL BE COVERED BY THE LIMITED 1 YEAR PARTS AND LABOR WARRANTY.** Note: This warranty does not cover labor costs for the removal and reinstallation of the unit.

**BY PURCHASING THIS PRODUCT, THE CONSUMER AGREES AND CONSENTS THAT ALL DISPUTES BETWEEN THE CONSUMER AND DIRECTED SHALL BE RESOLVED IN ACCORDANCE WITH CALIFORNIA LAWS IN SAN DIEGO COUNTY, CALIFORNIA.**



Designed and Manufactured in the USA by

**Directed**  
ELECTRONICS, INC.