

Read Me First: Unpacking Express5800/320Fc Systems

NEC Corporation of America
456-01722-000

Notice

The information contained in this document is subject to change without notice.

UNLESS EXPRESSLY SET FORTH IN A WRITTEN AGREEMENT SIGNED BY AN AUTHORIZED REPRESENTATIVE OF NEC, NEC MAKES NO WARRANTY OR REPRESENTATION OF ANY KIND WITH RESPECT TO THE INFORMATION CONTAINED HEREIN, INCLUDING WARRANTY OF MERCHANTABILITY AND FITNESS FOR A PURPOSE. NEC assumes no responsibility or obligation of any kind for any errors contained herein or in connection with the furnishing, performance, or use of this document.

Software described in NEC (a) is the property of NEC and/or its licensees, (b) is furnished only under license, and (c) may be copied or used only as expressly permitted under the terms of the license.

NEC documentation describes all supported features of the user interfaces and the application programming interfaces (API) developed by NEC and/or its licensees. Any undocumented features of these interfaces are intended solely for use by NEC personnel and are subject to change without warning.

This document is protected by copyright. All rights are reserved. No part of this document may be copied, reproduced, or translated, either mechanically or electronically, without the prior written consent of NEC Corporation of America.

The NEC Corporation of America logo, Express5800/320Fc, and the Express5800/320Fc logo, are trademarks of NEC Corporation of America. ActiveService Network is a trademark of Stratus Technologies Bermuda, Ltd. All other trademarks and trade names are the property of their respective owners.

Manual Name: *Read Me First: Unpacking Express5800/320Fc Systems*

Part Number: 456-01722-000

Revision Number: 0

Publication Date: August 2007

NEC Corporation of America
10850 Gold Center Drive, Suite 200
Rancho Cordova, CA 95670

Contents

Introduction	1
Before Unpacking the System	4
Unpacking the System	4
Disposing of Packing Materials	6
What to Do Next	6

Introduction

Read Me First: Unpacking Express5800/320Fc Systems explains how to unpack a system from its shipping box.



WARNING _____

To avoid eye and skin injuries, be careful when cutting the shipping straps from the shipping box. The straps can snap with considerable force when cut.



WARNING _____

To avoid back injury, do not attempt to remove an enclosure before you remove the shipping box from the shipping pallet. When the shipping box is removed, lift and remove each enclosure with the assistance of another person.



WARNING _____

To avoid back injury, enlist the assistance of another person to lift and remove the enclosures and pedestal case.

Figure 1 shows the packaged components, and the order in which to remove them, for a rack-mounted system. Figure 2 shows the packaged components, and the order in which to remove them, for a pedestal system.

Figure 1. Unpacking a Rack-Mounted System

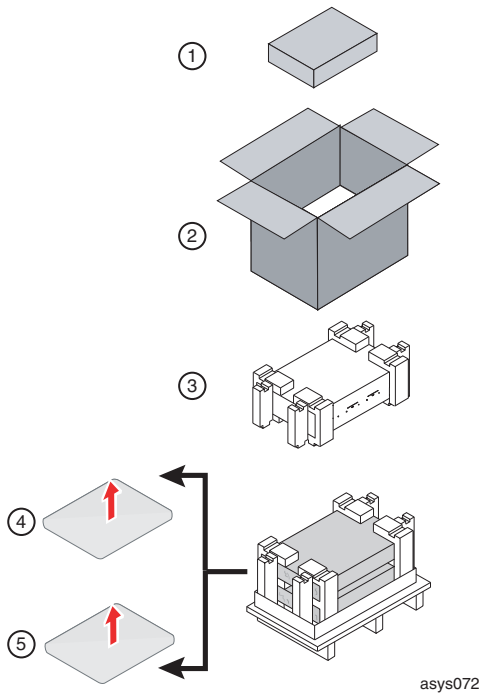

- 1 Accessories box
- 2 Shipping box
- 3 Shelf unit
- 4 and 5 CPU-I/O enclosures

Figure 2. Unpacking a Pedestal System

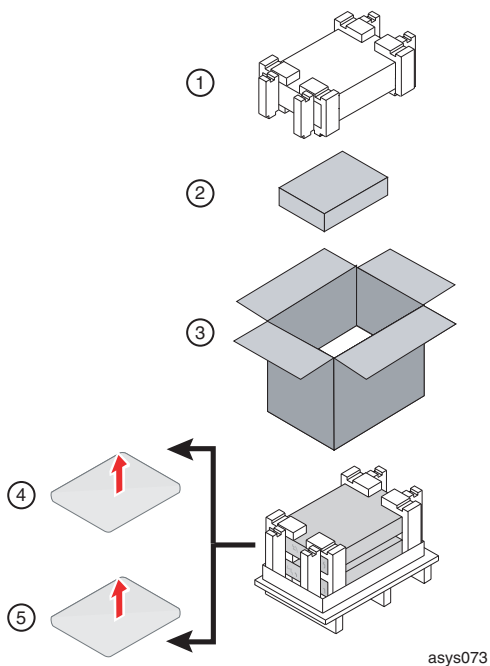

- 1 Pedestal case
- 2 Accessories box
- 3 Shipping box
- 4 and 5 CPU-I/O enclosures

Before Unpacking the System

- Check the label or the packing slip on the outside of the shipping box to verify that you received the correct shipment.

Depending on your order, you have received either a rack-mountable system or a pedestal system.

- Verify that the Tip-N-Tell and Shockwatch indicators on the outer sides of the shipping box are not activated.



CAUTION

Do not unpack the system if you did not receive the correct shipment, or if an indicator on the shipping box is activated. Contact the shipping carrier and the purchasing agent for your system immediately.

Unpacking the System

Tools needed: A pair of scissors or a utility knife

1. Place the shipping box in the location where the system will be installed, leaving it right side up on its shipping pallet.
2. Use the scissors or knife to cut the shipping straps and remove them from the shipping box. To avoid injury while cutting each strap, hold the strap firmly with one hand as you stand away from it.



WARNING

To avoid eye or skin injuries, be careful when cutting the straps from the box. The straps can snap with considerable force when cut.

3. Open the top cardboard flaps of the shipping box by cutting through the taped portion of the flaps to release them.
4. If you have received a pedestal system, remove the pedestal case, place it on a table or other sturdy surface, and remove its foam packaging material.



WARNING

To avoid back injury, lift and remove the pedestal case with the assistance of another person.

5. Remove the accessories box. Open the accessories box and make sure that it contains (along with other items) the *Express5800/320Fc: Setup Guide*.
6. Lift and remove the shipping box from the shipping pallet.



WARNING

To avoid back injury, do not attempt to remove the shelf unit or enclosures before you remove the shipping box from the shipping pallet.

7. If you received a rack-mountable system, remove the shelf unit and place it on a table or other sturdy surface and remove its foam packaging material.

8. Remove each CPU-I/O enclosure, one at a time, from the shipping pallet. Pull the foam blocks away from the first enclosure and remove it. Then, do the same for the second enclosure.



WARNING

To avoid back injury, lift and remove each enclosure with the assistance of another person.

9. Remove the enclosures from their plastic bags, then place the enclosures flat on a table or other sturdy work surface near the installation area.

Disposing of Packing Materials

The packing materials do not contain any hazardous compounds. Dispose of them according to applicable procedures or local regulations.

If, however, you decide to retain the undamaged container and its packing materials, you can use them to ship the system at a later time.

What to Do Next

To install the system, see the *Express5800/320Fc: Setup Guide*.