

# INSTALLATION INSTRUCTIONS

## Performer RPM Fuel Pump

### For Harley Nitrous Systems

### For Big Twin Evolutions

### Catalog # 77500

PostScript Picture  
(Edelbrock B/W Logo.eps)

**Please study these instructions carefully before installing your new Edelbrock Nitrous System.** Failure to follow instruction will void warranty and may cause damage to parts and/or personal injury. If you have any questions or problems, please call our **Technical Hotline at: 1-800-416-8628**, 7:00 am – 5:00 pm, Pacific Standard Time, Monday through Friday or e-mail us at [edelbrock@edelbrock.com](mailto:edelbrock@edelbrock.com).

**ACCESSORIES & INSTALLATION ITEMS:** Major recommendations are listed below. However, due to the variety of years, makes and models to be covered, please review each part listed in the Installation Items section of the Edelbrock catalog to decide whether more items are required for your specific application than are mentioned in these instructions. See our catalog for details. **To order a catalog, call (800) FUN-TEAM.**

**WARNING:** *To avoid accidental start-up of vehicle and possible personal injury, disconnect the battery cables (negative cable first) before performing any of the following procedures:*

1. Remove seat if necessary .
2. Turn petcock to off position, disconnect Nitrous fuel line.  
**Warning: Gasoline is flammable and fumes are explosive. To avoid possible personal injury, drain gasoline in well-ventilated area away from fire or flame. Drain gasoline into approved gasoline container only.**
3. Remove chrome module cover.
4. Remove Allen screws "A" as seen in figure 1.
5. Remove Positive and ground leads "B" from fuel pump as seen in figure 2. Also remove fuel line hose clamps.
6. Remove Allen screws "C" as seen in figure 2.
7. Remove fuel pump.
8. Install new fuel pump reversing the above procedures.

Figure 1

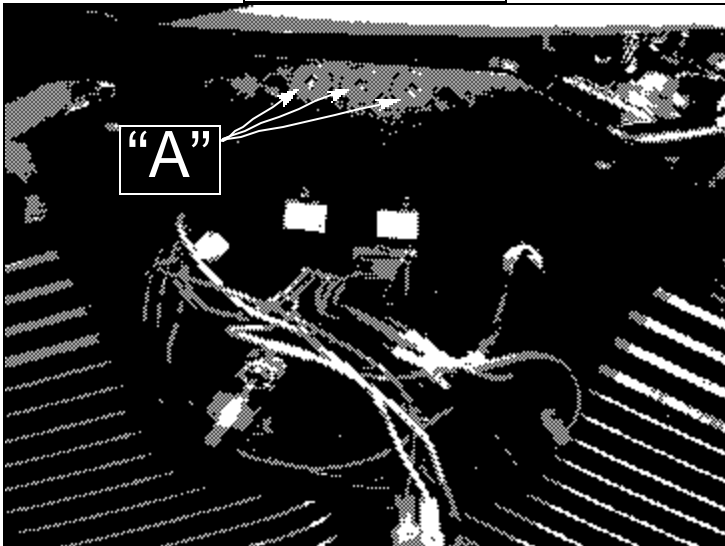
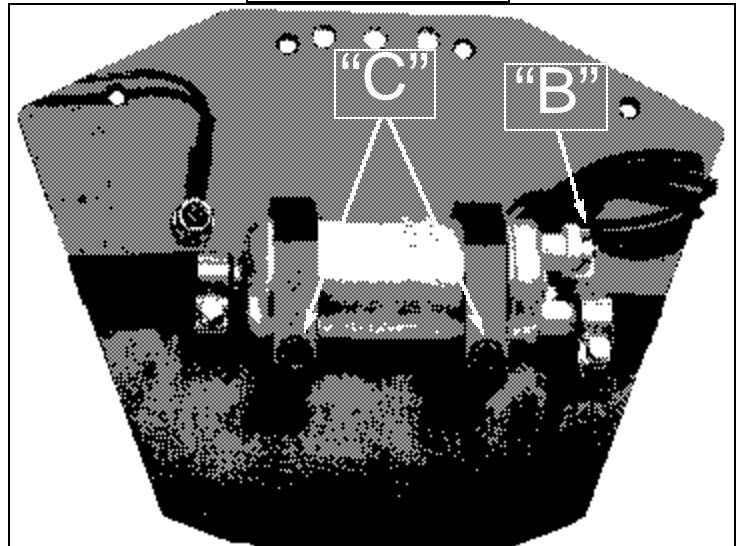

Figure 2



**Edelbrock Corporation**  
**2700 California Street**  
**Torrance, California 90503**  
**Tech Line: (800) 416-8628**  
**Office: (310) 781-2222**  
**www.edelbrock.com**