



INSTALLATION INSTRUCTIONS

Acura Integra GSR VTEC Throttle Body Catalog #4790

- **Please** study these instructions carefully before installing your new throttle body. If you have any questions or problems, please call our **Technical Hotline at: 1-800-416-8628**, 7:00 am – 5:00 pm, Pacific Standard Time, Monday through Friday or e-mail us at edelbrock@edelbrock.com.
- This part is street legal in all 50 states for use on 1994-2001 Acura Integra GSR 1.8L Vtec.

Throttle Body Kit Contents:

- 1 - Throttle body to manifold gasket
- 1 - Fast idle thermo valve o-ring with white stripe
- 1 - Fast idle thermo valve o-ring with red stripe
- 1 - Fast idle thermo valve o-ring with green stripe
- 1 - MAP sensor o-ring with blue strip
- 1 - E.O. # fan shroud decal

INSTALLATION INSTRUCTIONS

1. Please read through the entire instruction sheet to familiarize yourself with the parts of the vehicle the installation will deal with.
2. Start the engine and check for loose connections or coolant/vacuum leaks, etc.
3. Disconnect the negative battery terminal.
4. Remove the air filter duct, all vacuum hoses, water (coolant) hoses and electrical connectors from the stock throttle body. Mark all hoses and wires to ensure that they are installed correctly on the new throttle body. **Note:** *Engine coolant may run from the hoses once removed.*
5. Disconnect the throttle linkage by opening the throttle manually and slipping the cable from the cam groove on the linkage.
6. Remove the four nuts securing the throttle body to the intake manifold and remove it.
7. Remove the MAP (see Figure 1 for MAP sensor location) sensor from the factory throttle body. Use the new O-ring with the blue stripe from the kit contents to seal the MAP sensor to the throttle body. Attach the MAP sensor to the new throttle body using the factory screws.
8. Remove the idle air control (IAC) motor (see Figure 1 for IAC motor location) from the factory throttle body. Using the factory bolts and the O-rings supplied in the kit, attach the IAC to the new throttle body. The o-rings are color-coded so refer to Figure 1 for proper installation. Torque down bolts to 10 N·m or 7 lbf·ft.

Note: To achieve the maximum benefits when re-using the factory intake manifold, you should match the opening on the intake manifold to the size of the new throttle body bore. The manifold should be hand-ground **OFF** the engine and thoroughly cleaned prior to re-installation. If using Edelbrock Victor X PN 4760, 4761 or 47601, no grinding is needed. These manifolds are already bore-matched to this throttle body. Refer to the OEM owner's manual for removal/installation procedure of the intake manifold. Use the gasket as a template to mark the manifold for grinding.

9. Be certain the gasket-mating surface on the intake manifold is clean and free of debris. Using the factory nuts and bolts and the new gasket supplied in the kit, attach the throttle body to the intake manifold. Torque nuts and bolts down to 20 N·m or 14 lbf·ft.
10. Slip the throttle cable on the linkage arm.
11. Observe the throttle body while an assistant presses and releases the gas pedal to ensure that the throttle blade opens and closes completely as well as smoothly.
12. Re-attach the air filter duct, all vacuum hoses, coolant hoses and electrical connectors on the new throttle body.
13. Re-connect the negative battery terminal.
14. Start the engine and check for loose connections or coolant/vacuum leaks, etc.
15. After the engine is warmed up, check the idle speed (refer to owners manual).
16. Double-check all fasteners, clamps, and electrical connections to ensure they are all secure.

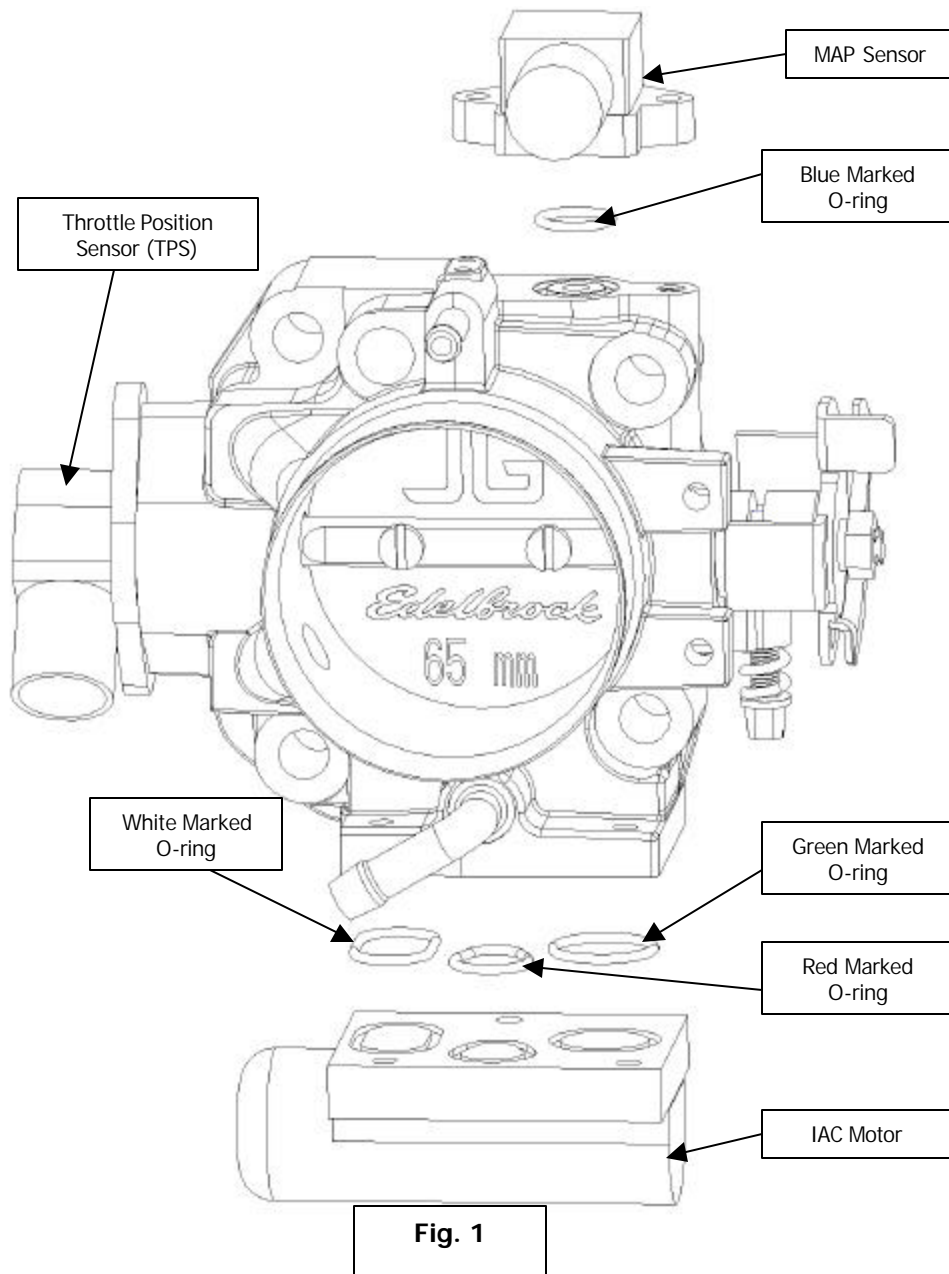

SPECIAL INSTRUCTIONS FOR E.O. NUMBER DECAL

SPECIAL NOTE: This Edelbrock part has received an Executive Order number (E.O. #) from the California Air Resource Board (C.A.R.B.) making it legal for street use on pollution-controlled motor vehicles in all 50 states. To assist you with emissions equipment certification, we have included a silver E.O. Number decal to help testing personnel verify that this part is a legal replacement part on the vehicle for which it is cataloged. The adhesive-backed decal should be affixed to your hood underside next to the existing emission and engine specification decal. Do not cover your original equipment specification decal with the Edelbrock E.O. Number decal.

PLEASE complete and mail your warranty card. Be sure to write the model number of this product in the "Part # _____" space.

Edelbrock Corporation - 2700 California Street - Torrance - California 90503

