



OM-1581

137 532Y

2007-01

Processes



MIG (GMAW) Welding

Description



Wire Feeder And Feeder Gun

XR™ A And XR™ W

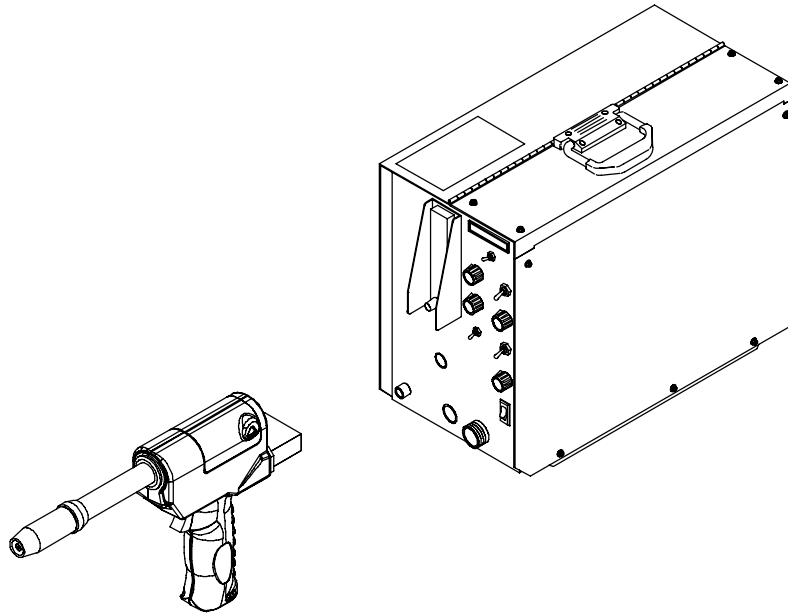

OWNER'S MANUAL



Visit our website at

www.MillerWelds.com

File: MIG (GMAW)



From Miller to You

Thank you and congratulations on choosing Miller. Now you can get the job done and get it done right. We know you don't have time to do it any other way.

That's why when Niels Miller first started building arc welders in 1929, he made sure his products offered long-lasting value and superior quality. Like you, his customers couldn't afford anything less. Miller products had to be more than the best they could be. They had to be the best you could buy.

Today, the people that build and sell Miller products continue the tradition. They're just as committed to providing equipment and service that meets the high standards of quality and value established in 1929.

This Owner's Manual is designed to help you get the most out of your Miller products. Please take time to read the Safety precautions. They will help you protect yourself against potential hazards on the worksite.

We've made installation and operation quick and easy. With Miller you can count on years of reliable service with proper maintenance. And if for some reason the unit needs repair, there's a Troubleshooting section that will help you figure out what the problem is. The parts list will then help you to decide the exact part you may need to fix the problem. Warranty and service information for your particular model are also provided.



Miller is the first welding equipment manufacturer in the U.S.A. to be registered to the ISO 9001:2000 Quality System Standard.

Miller Electric manufactures a full line of welders and welding related equipment. For information on other quality Miller products, contact your local Miller distributor to receive the latest full line catalog or individual specification sheets. **To locate your nearest distributor or service agency call 1-800-4-A-Miller, or visit us at www.MillerWelds.com on the web.**



Working as hard as you do – every power source from Miller is backed by the most hassle-free warranty in the business.



TABLE OF CONTENTS

SECTION 1 – SAFETY PRECAUTIONS - READ BEFORE USING	1
1-1. Symbol Usage	1
1-2. Arc Welding Hazards	1
1-3. Additional Symbols For Installation, Operation, And Maintenance	3
1-4. California Proposition 65 Warnings	3
1-5. Principal Safety Standards	4
1-6. EMF Information	4
SECTION 2 – CONSIGNES DE SÉCURITÉ – LIRE AVANT UTILISATION	5
2-1. Symboles utilisés	5
2-2. Dangers relatifs au soudage à l'arc	5
2-3. Dangers supplémentaires en relation avec l'installation, le fonctionnement et la maintenance	7
2-4. Proposition californienne 65 Avertissements	7
2-5. Principales normes de sécurité	8
2-6. Information EMF	8
SECTION 3 – SPECIFICATIONS	9
3-1. Wire Feeder Specifications	9
3-2. Gun Specifications	9
3-3. Duty Cycle And Overheating	9
SECTION 4 – INSTALLATION	10
4-1. Connections With A CC, CV Or CC/CV Voltage Welding Power Source Having A 14-Socket Receptacle 10	10
4-2. Connections With A CV Welding Power Source Having Separate 115 VAC And Contactor Control Receptacles	11
4-3. Connections With A CC Welding Power Source Having A Contactor Control Receptacle	11
4-4. Connections With A CC Welding Power Source And A 115 VAC/12 VDC Secondary Contactor	12
4-5. Removing Top Cover Of Pistol Grip Gun	12
4-6. Air-Cooled Gun Connections	13
4-7. Water-Cooled Gun Connections	14
4-8. Air-Cooled Feeder Connections	15
4-9. Water-Cooled Feeder Connections	16
4-10. Voltage Sensing Lead Connections	17
4-11. 115 VAC/Contactor Control Plug Information	18
4-12. Replacing 115 VAC/Contactor Control Plug With Customer-Supplied 5-Pin Or Twistlock Plug	19
4-13. Installing Wire Spool	20
4-14. Threading Welding Wire Through Feeder	21
4-15. Threading Welding Wire Through Gun	22
4-16. Coolant Guidelines	22
4-17. Adjusting Wire Feed Starting Speed	23

TABLE OF CONTENTS

SECTION 5 – OPERATION	24
5-1. Front Panel Controls Of Feeder (Air-Cooled Model Shown)	24
5-2. Safety Equipment	24
5-3. Work And Voltage Sensing Cable Clamps	24
5-4. Run-In Speed Control	25
5-5. Jog Switch	25
5-6. Voltage/Wire Speed Switch And Meter (Optional)	25
5-7. Spot Controls (Optional)	26
5-8. Remote Voltage Control (Optional)	26
5-9. Power Switch	26
5-10. Flowmeter (Optional)	27
5-11. Internal Controls	27
5-12. Gun Controls	28
5-13. Shielding Gas	28
5-14. Coolant Supply For Water-Cooled Models Only	28
5-15. Sequence Of Gas Metal Arc Welding (GMAW) – Continuous Or Spot	28
SECTION 6 – MAINTENANCE & TROUBLESHOOTING	29
6-1. Routine Maintenance	29
6-2. Changing Or Cleaning Gun Drive Roll	30
6-3. Changing Feeder Drive Roll And Wire Inlet Guide	31
6-4. Replacing Or Cleaning Gun Drive Roll Bearing	32
6-5. Replacing Or Cleaning Feeder Drive Roll Bearing	32
6-6. Changing Gun Contact Tip	33
6-7. Removing Diffuser In Air And Water-Cooled Pistol-Grip Guns	33
6-8. Replacing The Liner	34
6-9. Replacing Hub Assembly	35
6-10. Adjusting Hub Tension	36
6-11. Overload Protection	36
6-12. Water Flow Switch (Optional For Water-Cooled Models)	36
6-13. Troubleshooting	37
SECTION 7 – ELECTRICAL DIAGRAMS	39
SECTION 8 – PARTS LIST	42
SECTION 9 – PARTS LIST INCLUDING CONSUMABLES	52

SECTION 1 – SAFETY PRECAUTIONS - READ BEFORE USING

som _3/05

▲ **Warning: Protect yourself and others from injury — read and follow these precautions.**

1-1. Symbol Usage



Means Warning! Watch Out! There are possible hazards with this procedure! The possible hazards are shown in the adjoining symbols.

▲ **Marks a special safety message.**

☞ Means "Note"; not safety related.



This group of symbols means Warning! Watch Out! possible ELECTRIC SHOCK, MOVING PARTS, and HOT PARTS hazards. Consult symbols and related instructions below for necessary actions to avoid the hazards.

1-2. Arc Welding Hazards

▲ **The symbols shown below are used throughout this manual to call attention to and identify possible hazards. When you see the symbol, watch out, and follow the related instructions to avoid the hazard. The safety information given below is only a summary of the more complete safety information found in the Safety Standards listed in Section 1-5. Read and follow all Safety Standards.**

▲ **Only qualified persons should install, operate, maintain, and repair this unit.**

▲ **During operation, keep everybody, especially children, away.**



ELECTRIC SHOCK can kill.

Touching live electrical parts can cause fatal shocks or severe burns. The electrode and work circuit is electrically live whenever the output is on. The input power circuit and machine internal circuits are also

live when power is on. In semiautomatic or automatic wire welding, the wire, wire reel, drive roll housing, and all metal parts touching the welding wire are electrically live. Incorrectly installed or improperly grounded equipment is a hazard.

- Do not touch live electrical parts.
- Wear dry, hole-free insulating gloves and body protection.
- Insulate yourself from work and ground using dry insulating mats or covers big enough to prevent any physical contact with the work or ground.
- Do not use AC output in damp areas, if movement is confined, or if there is a danger of falling.
- Use AC output ONLY if required for the welding process.
- If AC output is required, use remote output control if present on unit.
- Additional safety precautions are required when any of the following electrically hazardous conditions are present: in damp locations or while wearing wet clothing; on metal structures such as floors, gratings, or scaffolds; when in cramped positions such as sitting, kneeling, or lying; or when there is a high risk of unavoidable or accidental contact with the workpiece or ground. For these conditions, use the following equipment in order presented: 1) a semiautomatic DC constant voltage (wire) welder, 2) a DC manual (stick) welder, or 3) an AC welder with reduced open-circuit voltage. In most situations, use of a DC, constant voltage wire welder is recommended. And, do not work alone!
- Disconnect input power or stop engine before installing or servicing this equipment. Lockout/tagout input power according to OSHA 29 CFR 1910.147 (see Safety Standards).
- Properly install and ground this equipment according to its Owner's Manual and national, state, and local codes.
- Always verify the supply ground – check and be sure that input power cord ground wire is properly connected to ground terminal in disconnect box or that cord plug is connected to a properly grounded receptacle outlet.
- When making input connections, attach proper grounding conductor first – double-check connections.
- Frequently inspect input power cord for damage or bare wiring – replace cord immediately if damaged – bare wiring can kill.

- Turn off all equipment when not in use.
- Do not use worn, damaged, undersized, or poorly spliced cables.
- Do not drape cables over your body.
- If earth grounding of the workpiece is required, ground it directly with a separate cable.
- Do not touch electrode if you are in contact with the work, ground, or another electrode from a different machine.
- Do not touch electrode holders connected to two welding machines at the same time since double open-circuit voltage will be present.
- Use only well-maintained equipment. Repair or replace damaged parts at once. Maintain unit according to manual.
- Wear a safety harness if working above floor level.
- Keep all panels and covers securely in place.
- Clamp work cable with good metal-to-metal contact to workpiece or worktable as near the weld as practical.
- Insulate work clamp when not connected to workpiece to prevent contact with any metal object.
- Do not connect more than one electrode or work cable to any single weld output terminal.

SIGNIFICANT DC VOLTAGE exists in inverter-type welding power sources after removal of input power.

- Turn Off inverter, disconnect input power, and discharge input capacitors according to instructions in Maintenance Section before touching any parts.

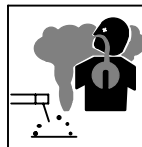

FUMES AND GASES can be hazardous.

Welding produces fumes and gases. Breathing these fumes and gases can be hazardous to your health.

- Keep your head out of the fumes. Do not breathe the fumes.
- If inside, ventilate the area and/or use local forced ventilation at the arc to remove welding fumes and gases.
- If ventilation is poor, wear an approved air-supplied respirator.
- Read and understand the Material Safety Data Sheets (MSDSs) and the manufacturer's instructions for metals, consumables, coatings, cleaners, and degreasers.
- Work in a confined space only if it is well ventilated, or while wearing an air-supplied respirator. Always have a trained watch-person nearby. Welding fumes and gases can displace air and lower the oxygen level causing injury or death. Be sure the breathing air is safe.
- Do not weld in locations near degreasing, cleaning, or spraying operations. The heat and rays of the arc can react with vapors to form highly toxic and irritating gases.
- Do not weld on coated metals, such as galvanized, lead, or cadmium plated steel, unless the coating is removed from the weld area, the area is well ventilated, and while wearing an air-supplied respirator. The coatings and any metals containing these elements can give off toxic fumes if welded.



ARC RAYS can burn eyes and skin.

Arc rays from the welding process produce intense visible and invisible (ultraviolet and infrared) rays that can burn eyes and skin. Sparks fly off from the weld.

- Wear an approved welding helmet fitted with a proper shade of filter lenses to protect your face and eyes when welding or watching (see ANSI Z49.1 and Z87.1 listed in Safety Standards).
- Wear approved safety glasses with side shields under your helmet.
- Use protective screens or barriers to protect others from flash, glare and sparks; warn others not to watch the arc.
- Wear protective clothing made from durable, flame-resistant material (leather, heavy cotton, or wool) and foot protection.



WELDING can cause fire or explosion.

Welding on closed containers, such as tanks, drums, or pipes, can cause them to blow up. Sparks can fly off from the welding arc. The flying sparks, hot workpiece, and hot equipment can cause fires and burns. Accidental contact of electrode to metal objects can cause sparks, explosion, overheating, or fire. Check and be sure the area is safe before doing any welding.

- Remove all flammables within 35 ft (10.7 m) of the welding arc. If this is not possible, tightly cover them with approved covers.
- Do not weld where flying sparks can strike flammable material.
- Protect yourself and others from flying sparks and hot metal.
- Be alert that welding sparks and hot materials from welding can easily go through small cracks and openings to adjacent areas.
- Watch for fire, and keep a fire extinguisher nearby.
- Be aware that welding on a ceiling, floor, bulkhead, or partition can cause fire on the hidden side.
- Do not weld on closed containers such as tanks, drums, or pipes, unless they are properly prepared according to AWS F4.1 (see Safety Standards).
- Connect work cable to the work as close to the welding area as practical to prevent welding current from traveling long, possibly unknown paths and causing electric shock, sparks, and fire hazards.
- Do not use welder to thaw frozen pipes.
- Remove stick electrode from holder or cut off welding wire at contact tip when not in use.
- Wear oil-free protective garments such as leather gloves, heavy shirt, cuffless trousers, high shoes, and a cap.
- Remove any combustibles, such as a butane lighter or matches, from your person before doing any welding.
- Follow requirements in OSHA 1910.252 (a) (2) (iv) and NFPA 51B for hot work and have a fire watcher and extinguisher nearby.

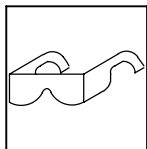

FLYING METAL can injure eyes.

- Welding, chipping, wire brushing, and grinding cause sparks and flying metal. As welds cool, they can throw off slag.
- Wear approved safety glasses with side shields even under your welding helmet.



BUILDUP OF GAS can injure or kill.

- Shut off shielding gas supply when not in use.
- Always ventilate confined spaces or use approved air-supplied respirator.



HOT PARTS can cause severe burns.

- Do not touch hot parts bare handed.
- Allow cooling period before working on gun or torch.
- To handle hot parts, use proper tools and/or wear heavy, insulated welding gloves and clothing to prevent burns.

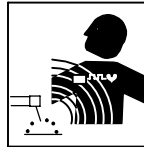

MAGNETIC FIELDS can affect pacemakers.

- Pacemaker wearers keep away.
- Wearers should consult their doctor before going near arc welding, gouging, or spot welding operations.

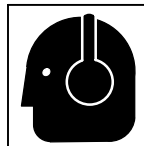

NOISE can damage hearing.

Noise from some processes or equipment can damage hearing.

- Wear approved ear protection if noise level is high.

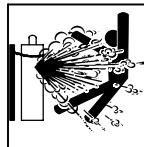

CYLINDERS can explode if damaged.

Shielding gas cylinders contain gas under high pressure. If damaged, a cylinder can explode. Since gas cylinders are normally part of the welding process, be sure to treat them carefully.

- Protect compressed gas cylinders from excessive heat, mechanical shocks, physical damage, slag, open flames, sparks, and arcs.
- Install cylinders in an upright position by securing to a stationary support or cylinder rack to prevent falling or tipping.
- Keep cylinders away from any welding or other electrical circuits.
- Never drape a welding torch over a gas cylinder.
- Never allow a welding electrode to touch any cylinder.
- Never weld on a pressurized cylinder – explosion will result.
- Use only correct shielding gas cylinders, regulators, hoses, and fittings designed for the specific application; maintain them and associated parts in good condition.
- Turn face away from valve outlet when opening cylinder valve.
- Keep protective cap in place over valve except when cylinder is in use or connected for use.
- Use the right equipment, correct procedures, and sufficient number of persons to lift and move cylinders.
- Read and follow instructions on compressed gas cylinders, associated equipment, and Compressed Gas Association (CGA) publication P-1 listed in Safety Standards.

1-3. Additional Symbols For Installation, Operation, And Maintenance



FIRE OR EXPLOSION hazard.

- Do not install or place unit on, over, or near combustible surfaces.
- Do not install unit near flammables.
- Do not overload building wiring – be sure power supply system is properly sized, rated, and protected to handle this unit.



FALLING UNIT can cause injury.

- Use lifting eye to lift unit only, NOT running gear, gas cylinders, or any other accessories.
- Use equipment of adequate capacity to lift and support unit.
- If using lift forks to move unit, be sure forks are long enough to extend beyond opposite side of unit.



OVERUSE can cause OVERHEATING

- Allow cooling period; follow rated duty cycle.
- Reduce current or reduce duty cycle before starting to weld again.
- Do not block or filter airflow to unit.



STATIC (ESD) can damage PC boards.

- Put on grounded wrist strap BEFORE handling boards or parts.
- Use proper static-proof bags and boxes to store, move, or ship PC boards.



MOVING PARTS can cause injury.

- Keep away from moving parts.
- Keep away from pinch points such as drive rolls.



WELDING WIRE can cause injury.

- Do not press gun trigger until instructed to do so.
- Do not point gun toward any part of the body, other people, or any metal when threading welding wire.



MOVING PARTS can cause injury.

- Keep away from moving parts such as fans.
- Keep all doors, panels, covers, and guards closed and securely in place.
- Have only qualified persons remove doors, panels, covers, or guards for maintenance as necessary.
- Reinstall doors, panels, covers, or guards when maintenance is finished and before re-connecting input power.

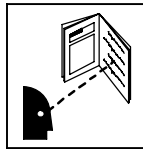

READ INSTRUCTIONS.

- Read Owner's Manual before using or servicing unit.
- Use only genuine Miller/Hobart replacement parts.

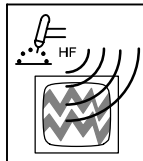

H.F. RADIATION can cause interference.

- High-frequency (H.F.) can interfere with radio navigation, safety services, computers, and communications equipment.
- Have only qualified persons familiar with electronic equipment perform this installation.
- The user is responsible for having a qualified electrician promptly correct any interference problem resulting from the installation.
- If notified by the FCC about interference, stop using the equipment at once.
- Have the installation regularly checked and maintained.
- Keep high-frequency source doors and panels tightly shut, keep spark gaps at correct setting, and use grounding and shielding to minimize the possibility of interference.

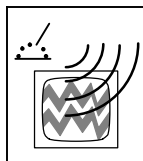

ARC WELDING can cause interference.

- Electromagnetic energy can interfere with sensitive electronic equipment such as computers and computer-driven equipment such as robots.
- Be sure all equipment in the welding area is electromagnetically compatible.
- To reduce possible interference, keep weld cables as short as possible, close together, and down low, such as on the floor.
- Locate welding operation 100 meters from any sensitive electronic equipment.
- Be sure this welding machine is installed and grounded according to this manual.
- If interference still occurs, the user must take extra measures such as moving the welding machine, using shielded cables, using line filters, or shielding the work area.

1-4. California Proposition 65 Warnings

- ▲ **Welding or cutting equipment produces fumes or gases which contain chemicals known to the State of California to cause birth defects and, in some cases, cancer. (California Health & Safety Code Section 25249.5 et seq.)**
- ▲ **Battery posts, terminals and related accessories contain lead and lead compounds, chemicals known to the State of California to cause cancer and birth defects or other reproductive harm. Wash hands after handling.**

For Gasoline Engines:

- ▲ **Engine exhaust contains chemicals known to the State of California to cause cancer, birth defects, or other reproductive harm.**

For Diesel Engines:

- ▲ **Diesel engine exhaust and some of its constituents are known to the State of California to cause cancer, birth defects, and other reproductive harm.**

1-5. Principal Safety Standards

Safety in Welding, Cutting, and Allied Processes, ANSI Standard Z49.1, from Global Engineering Documents (phone: 1-877-413-5184, website: www.global.ihs.com).

Recommended Safe Practices for the Preparation for Welding and Cutting of Containers and Piping, American Welding Society Standard AWS F4.1 from Global Engineering Documents (phone: 1-877-413-5184, website: www.global.ihs.com).

National Electrical Code, NFPA Standard 70, from National Fire Protection Association, P.O. Box 9101, 1 Battery March Park, Quincy, MA 02269-9101 (phone: 617-770-3000, website: www.nfpa.org).

Safe Handling of Compressed Gases in Cylinders, CGA Pamphlet P-1, from Compressed Gas Association, 1735 Jefferson Davis Highway, Suite 1004, Arlington, VA 22202-4102 (phone: 703-412-0900, website: www.cganet.com).

Code for Safety in Welding and Cutting, CSA Standard W117.2, from Canadian Standards Association, Standards Sales, 178 Rexdale

Boulevard, Rexdale, Ontario, Canada M9W 1R3 (phone: 800-463-6727 or in Toronto 416-747-4044, website: www.csa-international.org).

Practice For Occupational And Educational Eye And Face Protection, ANSI Standard Z87.1, from American National Standards Institute, 11 West 42nd Street, New York, NY 10036-8002 (phone: 212-642-4900, website: www.ansi.org).

Standard for Fire Prevention During Welding, Cutting, and Other Hot Work, NFPA Standard 51B, from National Fire Protection Association, P.O. Box 9101, 1 Battery March Park, Quincy, MA 02269-9101 (phone: 617-770-3000, website: www.nfpa.org).

OSHA, Occupational Safety and Health Standards for General Industry, Title 29, Code of Federal Regulations (CFR), Part 1910, Subpart Q, and Part 1926, Subpart J, from U.S. Government Printing Office, Superintendent of Documents, P.O. Box 371954, Pittsburgh, PA 15250 (there are 10 Regional Offices—phone for Region 5, Chicago, is 312-353-2220, website: www.osha.gov).

1-6. EMF Information

Considerations About Welding And The Effects Of Low Frequency Electric And Magnetic Fields

Welding current, as it flows through welding cables, will cause electromagnetic fields. There has been and still is some concern about such fields. However, after examining more than 500 studies spanning 17 years of research, a special blue ribbon committee of the National Research Council concluded that: "The body of evidence, in the committee's judgment, has not demonstrated that exposure to power-frequency electric and magnetic fields is a human-health hazard." However, studies are still going forth and evidence continues to be examined. Until the final conclusions of the research are reached, you may wish to minimize your exposure to electromagnetic fields when welding or cutting.

To reduce magnetic fields in the workplace, use the following procedures:

1. Keep cables close together by twisting or taping them.
2. Arrange cables to one side and away from the operator.
3. Do not coil or drape cables around your body.
4. Keep welding power source and cables as far away from operator as practical.
5. Connect work clamp to workpiece as close to the weld as possible.

About Pacemakers:

Pacemaker wearers consult your doctor before welding or going near welding operations. If cleared by your doctor, then following the above procedures is recommended.

SECTION 2 – CONSIGNES DE SÉCURITÉ – LIRE AVANT UTILISATION

som _3/05

▲ **Avertissement : se protéger et protéger les autres contre le risque de blessure — lire et respecter ces consignes.**

2-1. Symboles utilisés



Symbole graphique d'avertissement ! Attention ! Cette procédure comporte des risques possibles ! Les dangers éventuels sont représentés par les symboles graphiques joints.



Ce groupe de symboles signifie Avertissement ! Attention ! Risques d'ÉLECTROCUTION, ORGANES MOBILES et PARTIES CHAUDES. Consulter les symboles et les instructions afférentes ci-dessous concernant les mesures à prendre pour supprimer les dangers.

▲ **Indique un message de sécurité particulier**

☞ Signifie NOTE ; n'est pas relatif à la sécurité.

2-2. Dangers relatifs au soudage à l'arc

▲ **Les symboles représentés ci-dessous sont utilisés dans ce manuel pour attirer l'attention et identifier les dangers possibles. En présence de l'un de ces symboles, prendre garde et suivre les instructions afférentes pour éviter tout risque. Les instructions en matière de sécurité indiquées ci-dessous ne constituent qu'un sommaire des instructions de sécurité plus complètes fournies dans les normes de sécurité énumérées dans la Section 2-5. Lire et observer toutes les normes de sécurité.**

▲ **Seul un personnel qualifié est autorisé à installer, faire fonctionner, entretenir et réparer cet appareil.**

▲ **Pendant le fonctionnement, maintenir à distance toutes les personnes, notamment les enfants de l'appareil.**



UNE DÉCHARGE ÉLECTRIQUE peut entraîner la mort.

Le contact d'organes électriques sous tension peut provoquer des accidents mortels ou des brûlures graves. Le circuit de l'électrode et de la pièce est sous tension lorsque le courant est délivré à la sortie. Le circuit d'alimentation et les circuits internes de la machine sont également sous tension lorsque l'alimentation est sur Marche. Dans le mode de soudage avec du fil, le fil, le dérouleur, le bloc de commande du rouleau et toutes les parties métalliques en contact avec le fil sont sous tension électrique. Un équipement installé ou mis à la terre de manière incorrecte ou impropre constitue un danger.

- Ne pas toucher aux pièces électriques sous tension.
- Porter des gants isolants et des vêtements de protection secs et sans trous.
- S'isoler de la pièce à couper et du sol en utilisant des housses ou des tapis assez grands afin d'éviter tout contact physique avec la pièce à couper ou le sol.
- Ne pas se servir de source électrique à courant électrique dans les zones humides, dans les endroits confinés ou là où on risque de tomber.
- Se servir d'une source électrique à courant électrique UNIQUEMENT si le procédé de soudage le demande.
- Si l'utilisation d'une source électrique à courant électrique s'avère nécessaire, se servir de la fonction de télécommande si l'appareil en est équipé.
- D'autres consignes de sécurité sont nécessaires dans les conditions suivantes : risques électriques dans un environnement humide ou si l'on porte des vêtements mouillés ; sur des structures métalliques telles que sols, grilles ou échafaudages ; en position coincée comme assise, à genoux ou couchée ; ou s'il y a un risque élevé de contact inévitable ou accidentel avec la pièce à souder ou le sol. Dans ces conditions, utiliser les équipements suivants, dans l'ordre indiqué : 1) un poste à souder DC à tension constante (à fil), 2) un poste à souder DC manuel (électrode) ou 3) un poste à souder AC à tension à vide réduite. Dans la plupart des situations, l'utilisation d'un poste à souder DC à fil à tension constante est recommandée. En outre, ne pas travailler seul !
- Couper l'alimentation ou arrêter le moteur avant de procéder à l'installation, à la réparation ou à l'entretien de l'appareil. Déverrouiller l'alimentation selon la norme OSHA 29 CFR 1910.147 (voir normes de sécurité).
- Installer le poste correctement et le mettre à la terre convenablement selon les consignes du manuel de l'opérateur et les normes nationales, provinciales et locales.
- Toujours vérifier la terre du cordon d'alimentation. Vérifier et s'assurer que le fil de terre du cordon d'alimentation est bien raccordé à la borne de terre du sectionneur ou que la fiche du cordon est raccordée à une prise correctement mise à la terre.
- En effectuant les raccordements d'entrée, fixer d'abord le conducteur de mise à la terre approprié et contre-vérifier les connexions.

- Vérifier fréquemment le cordon d'alimentation afin de s'assurer qu'il n'est pas altéré ou à nu, le remplacer immédiatement s'il l'est. Un fil à nu peut entraîner la mort.
- L'équipement doit être hors tension lorsqu'il n'est pas utilisé.
- Ne pas utiliser des câbles usés, endommagés, de grosseur insuffisante ou mal épluchés.
- Ne pas enrouler les câbles autour du corps.
- Si la pièce soudée doit être mise à la terre, le faire directement avec un câble distinct.
- Ne pas toucher l'électrode quand on est en contact avec la pièce, la terre ou une électrode provenant d'une autre machine.
- Ne pas toucher des porte électrodes connectés à deux machines en même temps à cause de la présence d'une tension à vide doublée.
- N'utiliser qu'un matériel en bon état. Réparer ou remplacer sur-le-champ les pièces endommagées. Entretien l'appareil conformément à ce manuel.
- Porter un harnais de sécurité si l'on doit travailler au-dessus du sol.
- S'assurer que tous les panneaux et couvercles sont correctement en place.
- Fixer le câble de retour de façon à obtenir un bon contact métal-métal avec la pièce à souder ou la table de travail, le plus près possible de la soudure.
- Isoler la pince de masse quand pas mis à la pièce pour éviter le contact avec tout objet métallique.
- Ne pas raccorder plus d'une électrode ou plus d'un câble de masse à une même borne de sortie de soudage.

Il reste une TENSION DC NON NÉGLIGEABLE dans les sources de soudage onduleur quand on a coupé l'alimentation.

- Arrêter les convertisseurs, débrancher le courant électrique et décharger les condensateurs d'alimentation selon les instructions indiquées dans la partie Entretien avant de toucher les pièces.

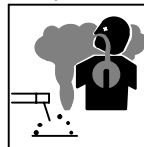

LES FUMÉES ET LES GAZ peuvent être dangereux.

Le soudage génère des fumées et des gaz. Leur inhalation peut être dangereuse pour la santé.

- Ne pas mettre sa tête au-dessus des vapeurs. Ne pas respirer ces vapeurs.
- À l'intérieur, ventiler la zone et/ou utiliser une ventilation forcée au niveau de l'arc pour l'évacuation des fumées et des gaz de soudage.
- Si la ventilation est médiocre, porter un respirateur anti-vapeurs approuvé.
- Lire et comprendre les spécifications de sécurité des matériaux (MSDS) et les instructions du fabricant concernant les métaux, les consommables, les revêtements, les nettoyants et les dégraisseurs.
- Travailler dans un espace fermé seulement s'il est bien ventilé ou en portant un respirateur à alimentation d'air. Demander toujours à un surveillant dûment formé de se tenir à proximité. Des fumées et des gaz de soudage peuvent déplacer l'air et abaisser le niveau d'oxygène provoquant des blessures ou des accidents mortels. S'assurer que l'air de respiration ne présente aucun danger.
- Ne pas souder dans des endroits situés à proximité d'opérations de dégraissage, de nettoyage ou de pulvérisation. La chaleur et les rayons de l'arc peuvent réagir en présence de vapeurs et former des gaz hautement toxiques et irritants.
- Ne pas souder des métaux munis d'un revêtement, tels que l'acier galvanisé, plaqué en plomb ou au cadmium à moins que le revêtement n'ait été enlevé dans la zone de soudure, que l'endroit soit bien ventilé et en portant un respirateur à alimentation d'air. Les revêtements et tous les métaux renfermant ces éléments peuvent dégager des fumées toxiques en cas de soudage.



LES RAYONS D'ARC peuvent entraîner des brûlures aux yeux et à la peau.

Le rayonnement de l'arc du procédé de soudage génère des rayons visibles et invisibles intenses (ultraviolets et infrarouges) susceptibles de provoquer des brûlures dans les yeux et sur la peau.

Des étincelles sont projetées pendant le soudage.

- Porter un casque de soudage approuvé muni de verres filtrants appropriés pour protéger visage et yeux pendant le soudage (voir ANSI Z49.1 et Z87.1 énumérés dans les normes de sécurité).
- Porter des lunettes de sécurité avec écrans latéraux même sous votre casque.
- Avoir recours à des écrans protecteurs ou à des rideaux pour protéger les autres contre les rayonnements les éblouissements et les étincelles ; prévenir toute personne sur les lieux de ne pas regarder l'arc.
- Porter des vêtements confectionnés avec des matières résistantes et ignifuges (cuir, coton lourd ou laine) et des bottes de protection.



LE SOUDAGE peut provoquer un incendie ou une explosion.

Le soudage effectué sur des conteneurs fermés tels que des réservoirs, tambours ou des conduites peut provoquer leur éclatement. Des étincelles peuvent être projetées de l'arc de soudure. La projection d'étincelles, des pièces chaudes et des équipements chauds peuvent provoquer des incendies et des brûlures. Le contact accidentel de l'électrode avec des objets métalliques peut provoquer des étincelles, une explosion, une surchauffe ou un incendie. Avant de commencer le soudage, vérifier et s'assurer que l'endroit ne présente pas de danger.

- Déplacer toutes les substances inflammables à une distance de 10,7 m de l'arc de soudage. En cas d'impossibilité, les recouvrir soigneusement avec des protections homologuées.
- Ne pas souder dans un endroit où des étincelles peuvent tomber sur des substances inflammables.
- Se protéger, ainsi que toute autre personne travaillant sur les lieux, contre les étincelles et le métal chaud.
- Des étincelles et des matériaux chauds du soudage peuvent facilement passer dans d'autres zones en traversant de petites fissures et des ouvertures.
- Afin d'éliminer tout risque de feu, être vigilant et garder toujours un extincteur à la portée de main.
- Le soudage effectué sur un plafond, plancher, paroi ou séparation peut déclencher un incendie de l'autre côté.
- Ne pas effectuer le soudage sur des conteneurs fermés tels que des réservoirs, tambours, ou conduites, à moins qu'ils n'aient été préparés correctement conformément à AWS F4.1 (voir les normes de sécurité).
- Brancher le câble de masse sur la pièce la plus près possible de la zone de soudage pour éviter le transport du courant sur une longue distance par des chemins inconnus éventuels en provoquant des risques d'électrocution, d'étincelles et d'incendie.
- Ne pas utiliser le poste de soudage pour dégelier des conduites gelées.
- En cas de non-utilisation, enlever la baguette d'électrode du porte-électrode ou couper le fil à la pointe de contact.
- Porter des vêtements de protection exempts d'huile tels que des gants en cuir, une veste résistante, des pantalons sans revers, des bottes et un casque.
- Avant de souder, retirer toute substance combustible de ses poches telles qu'un allumeur au butane ou des allumettes.
- Suivre les consignes de OSHA 1910.252 (a) (2) (iv) et de NFPA 51B pour travaux de soudage et prévoir un détecteur d'incendie et un extincteur à proximité.

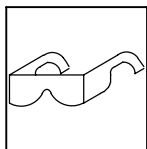

DES PARTICULES VOLANTES peuvent blesser les yeux.

- Le soudage, l'écaillage, le passage de la pièce à la brosse en fil de fer, et le meulage génèrent des étincelles et des particules métalliques volantes. Pendant la période de refroidissement des soudures, elles risquent de projeter du laitier.
- Porter des lunettes de sécurité avec écrans latéraux ou un écran facial.

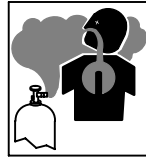

LES ACCUMULATIONS DE GAZ risquent de provoquer des blessures ou même la mort.

- Fermer l'alimentation du gaz protecteur en cas de non-utilisation.
- Veiller toujours à bien aérer les espaces confinés ou se servir d'un respirateur d'adduction d'air homologué.



DES PIÈCES CHAUDES peuvent provoquer des brûlures graves.

- Ne pas toucher des parties chaudes à mains nues.
- Prévoir une période de refroidissement avant d'utiliser le pistolet ou la torche.
- Ne pas toucher aux pièces chaudes, utiliser les outils recommandés et porter des gants de soudage et des vêtements épais pour éviter les brûlures.

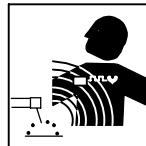

LES CHAMPS MAGNÉTIQUES peuvent affecter les stimulateurs cardiaques.

- Porteurs de stimulateur cardiaque, rester à distance.
- Les porteurs d'un stimulateur cardiaque doivent d'abord consulter leur médecin avant de s'approcher des opérations de soudage à l'arc, de gougeage ou de soudage par points.

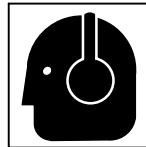

LE BRUIT peut endommager l'ouïe.

Le bruit des processus et des équipements peut affecter l'ouïe.

- Porter des protections approuvées pour les oreilles si le niveau sonore est trop élevé.

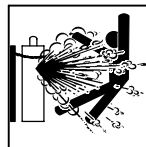

LES BOUTEILLES peuvent exploser si elles sont endommagées.

Des bouteilles de gaz protecteur contiennent du gaz sous haute pression. Si une bouteille est endommagée, elle peut exploser. Du fait que les bouteilles de gaz font normalement partie du procédé de soudage, les manipuler avec précaution.

- Protéger les bouteilles de gaz comprimé d'une chaleur excessive, des chocs mécaniques, des dommages physiques, du laitier, des flammes ouvertes, des étincelles et des arcs.
- Placer les bouteilles debout en les fixant dans un support stationnaire ou dans un porte-bouteilles pour les empêcher de tomber ou de se renverser.
- Tenir les bouteilles éloignées des circuits de soudage ou autres circuits électriques.
- Ne jamais placer une torche de soudage sur une bouteille à gaz.
- Une électrode de soudage ne doit jamais entrer en contact avec une bouteille.
- Ne jamais souder une bouteille pressurisée – risque d'explosion.
- Utiliser seulement des bouteilles de gaz protecteur, régulateurs, tuyaux et raccords convenables pour cette application spécifique ; les maintenir ainsi que les éléments associés en bon état.
- Détourner votre visage du détendeur-régulateur lorsque vous ouvrez la soupape de la bouteille.
- Le couvercle du détendeur doit toujours être en place, sauf lorsque la bouteille est utilisée ou qu'elle est reliée pour usage ultérieur.
- Utiliser les équipements corrects, les bonnes procédures et suffisamment de personnes pour soulever et déplacer les bouteilles.
- Lire et suivre les instructions sur les bouteilles de gaz comprimé, l'équipement connexe et le dépliant P-1 de la CGA (Compressed Gas Association) mentionné dans les principales normes de sécurité.

2-3. Dangers supplémentaires en relation avec l'installation, le fonctionnement et la maintenance



Risque D'INCENDIE OU D'EXPLOSION.

- Ne pas placer l'appareil sur, au-dessus ou à proximité de surfaces inflammables.
- Ne pas installer l'appareil à proximité de produits inflammables.
- Ne pas surcharger l'installation électrique – s'assurer que l'alimentation est correctement dimensionnée et protégée avant de mettre l'appareil en service.



LA CHUTE DE L'APPAREIL peut blesser.

- Utiliser l'anneau de levage uniquement pour soulever l'appareil, NON PAS les chariots, les bouteilles de gaz ou tout autre accessoire.
- Utiliser un équipement de levage de capacité suffisante pour lever l'appareil.
- En utilisant des fourches de levage pour déplacer l'unité, s'assurer que les fourches sont suffisamment longues pour dépasser du côté opposé de l'appareil.

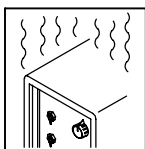

L'EMPLOI EXCESSIF peut SURCHAUFFER L'ÉQUIPEMENT.

- Prévoir une période de refroidissement ; respecter le cycle opératoire nominal.
- Réduire le courant ou le facteur de marche avant de poursuivre le soudage.
- Ne pas obstruer les passages d'air du poste.

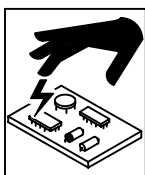

LES CHARGES ÉLECTROSTATIQUES peuvent endommager les circuits imprimés.

- Établir la connexion avec la barrette de terre avant de manipuler des cartes ou des pièces.
- Utiliser des pochettes et des boîtes antistatiques pour stocker, déplacer ou expédier des cartes PC.

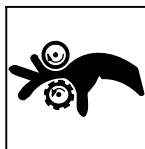

DES ORGANES MOBILES peuvent provoquer des blessures.

- Ne pas s'approcher des organes mobiles.
- Ne pas s'approcher des points de coincement tels que des rouleaux de commande.

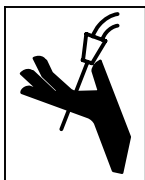

LES FILS DE SOUDAGE peuvent provoquer des blessures.

- Ne pas appuyer sur la gâchette avant d'en avoir reçu l'instruction.
- Ne pas diriger le pistolet vers soi, d'autres personnes ou toute pièce mécanique en engageant le fil de soudage.



DES ORGANES MOBILES peuvent provoquer des blessures.

- S'abstenir de toucher des organes mobiles tels que des ventilateurs.
- Maintenir fermés et verrouillés les portes, panneaux, recouvrements et dispositifs de protection.
- Seules des personnes qualifiées sont autorisées à enlever les portes, panneaux, recouvrements ou dispositifs de protection pour l'entretien.
- Remettre les portes, panneaux, recouvrements ou dispositifs de protection quand l'entretien est terminé et avant de rebrancher l'alimentation électrique.

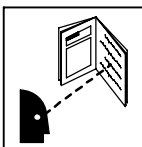

LIRE LES INSTRUCTIONS.

- Lire le manuel d'utilisation avant d'utiliser ou d'intervenir sur l'appareil.
- Utiliser uniquement des pièces de rechange Miller/Hobart.

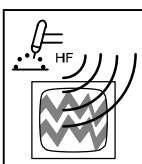

LE RAYONNEMENT HAUTE FRÉQUENCE (HF) risque de provoquer des interférences.

- Le rayonnement haute fréquence (HF) peut provoquer des interférences avec les équipements de radio-navigation et de communication, les services de sécurité et les ordinateurs.
- Demander seulement à des personnes qualifiées familiarisées avec des équipements électroniques de faire fonctionner l'installation.
- L'utilisateur est tenu de faire corriger rapidement par un électricien qualifié les interférences résultant de l'installation.
- Si le FCC signale des interférences, arrêter immédiatement l'appareil.
- Effectuer régulièrement le contrôle et l'entretien de l'installation.
- Maintenir soigneusement fermés les portes et les panneaux des sources de haute fréquence, maintenir les éclateurs à une distance correcte et utiliser une terre et un blindage pour réduire les interférences éventuelles.

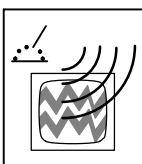

LE SOUDAGE À L'ARC risque de provoquer des interférences.

- L'énergie électromagnétique peut gêner le fonctionnement d'appareils électroniques comme des ordinateurs et des robots.
- Veiller à ce que tout l'équipement de la zone de soudage soit compatible électromagnétiquement.
- Pour réduire la possibilité d'interférence, maintenir les câbles de soudage aussi courts que possible, les grouper, et les poser aussi bas que possible (ex. par terre).
- Veiller à souder à une distance de 100 mètres de tout équipement électronique sensible.
- Veiller à ce que ce poste de soudage soit posé et mis à la terre conformément à ce mode d'emploi.
- En cas d'interférences après avoir pris les mesures précédentes, il incombe à l'utilisateur de prendre des mesures supplémentaires telles que le déplacement du poste, l'utilisation de câbles blindés, l'utilisation de filtres de ligne ou la pose de protecteurs dans la zone de travail.

2-4. Proposition californienne 65 Avertissements

▲ Les équipements de soudage et de coupage produisent des fumées et des gaz qui contiennent des produits chimiques dont l'État de Californie reconnaît qu'ils provoquent des malformations congénitales et, dans certains cas, des cancers. (Code de santé et de sécurité de Californie, chapitre 25249.5 et suivants)

▲ Les batteries, les bornes et autres accessoires contiennent du plomb et des composés à base de plomb, produits chimiques dont l'État de Californie reconnaît qu'ils provoquent des cancers et des malformations congénitales ou autres problèmes de procréation. Se laver les mains après manipulation.

Pour les moteurs à essence :

▲ Les gaz d'échappement des moteurs contiennent des produits chimiques dont l'État de Californie reconnaît qu'ils provoquent des cancers et des malformations congénitales ou autres problèmes de procréation.

Pour les moteurs diesel :

▲ Les gaz d'échappement des moteurs diesel et certains de leurs composants sont reconnus par l'État de Californie comme provoquant des cancers et des malformations congénitales ou autres problèmes de procréation.

2-5. Principales normes de sécurité

Safety in Welding, Cutting, and Allied Processes, ANSI Standard Z49.1, de Global Engineering Documents (téléphone : 1-877-413-5184, site Internet : www.global.ihs.com).

Recommended Safe Practices for the Preparation for Welding and Cutting of Containers and Piping, American Welding Society Standard AWS F4.1 de Global Engineering Documents (téléphone : 1-877-413-5184, site Internet : www.global.ihs.com).

National Electrical Code, NFPA Standard 70, de National Fire Protection Association, P.O. Box 9101, 1 Battery March Park, Quincy, MA 02269-9101 (téléphone : 617-770-3000, site Internet : www.nfpa.org).

Safe Handling of Compressed Gases in Cylinders, CGA Pamphlet P-1, de Compressed Gas Association, 1735 Jefferson Davis Highway, Suite 1004, Arlington, VA 22202-4102 (téléphone : 703-412-0900, site Internet : www.cganet.com).

Code for Safety in Welding and Cutting, CSA Standard W117.2, de Canadian Standards Association, Standards Sales, 178 Rexdale

Boulevard, Rexdale, Ontario, Canada M9W 1R3 (téléphone : 800-463-6727 ou à Toronto 416-747-4044, site Internet : www.csa-international.org).

Practice For Occupational And Educational Eye And Face Protection, ANSI Standard Z87.1, de American National Standards Institute, 11 West 42nd Street, New York, NY 10036-8002 (téléphone : 212-642-4900, site Internet : www.ansi.org).

Standard for Fire Prevention During Welding, Cutting, and Other Hot Work, NFPA Standard 51B, de National Fire Protection Association, P.O. Box 9101, 1 Battery March Park, Quincy, MA 02269-9101 (téléphone : 617-770-3000, site Internet : www.nfpa.org).

OSHA, Occupational Safety and Health Standards for General Industry, Title 29, Code of Federal Regulations (CFR), Part 1910, Subpart Q, and Part 1926, Subpart J, de U.S. Government Printing Office, Superintendent of Documents, P.O. Box 371954, Pittsburgh, PA 15250 (il y a 10 bureaux régionaux—le téléphone de la région 5, Chicago, est 312-353-2220, site Internet : www.osha.gov).

2-6. Information EMF

Considérations sur le soudage et les effets de basse fréquence et des champs magnétiques et électriques.

Le courant de soudage, pendant son passage dans les câbles de soudage, causera des champs électromagnétiques. Il y a eu et il y a encore un certain souci à propos de tels champs. Cependant, après avoir examiné plus de 500 études qui ont été faites pendant une période de recherche de 17 ans, un comité spécial ruban bleu du National Research Council a conclu : « L'accumulation de preuves, suivant le jugement du comité, n'a pas démontré que l'exposition aux champs magnétiques et champs électriques à haute fréquence représente un risque à la santé humaine ». Toutefois, des études sont toujours en cours et les preuves continuent à être examinées. En attendant que les conclusions finales de la recherche soient établies, il vous serait souhaitable de réduire votre exposition aux champs électromagnétiques pendant le soudage ou le coupage.

Pour réduire les champs magnétiques sur le poste de travail, appliquer les procédures suivantes :

1. Maintenir les câbles ensemble en les tordant ou en les enveloppant.
2. Disposer les câbles d'un côté et à distance de l'opérateur.
3. Ne pas courber pas et ne pas entourer pas les câbles autour de votre corps.
4. Garder le poste de soudage et les câbles le plus loin possible de vous.
5. Connecter la pince sur la pièce aussi près que possible de la soudeuse.

En ce qui concerne les stimulateurs cardiaques

Les porteurs de stimulateur cardiaque doivent consulter leur médecin avant de souder ou d'approcher des opérations de soudage. Si le médecin approuve, il est recommandé de suivre les procédures précédentes.

SECTION 3 – SPECIFICATIONS



3-1. Wire Feeder Specifications

Specification	Description
Type Of Input Power	115 Volts AC, 3 Amperes At 50/60 Or 100 Hz Power
Control Circuit Voltage Provided At Gun	30 Volts DC
Wire Feed Speed Range	70-875 ipm (1.9-22.2 mpm)
Overall Dimensions	Length: 19 in (483 mm); Width: 9-1/4 in (235 mm); Height: 15-1/4 in (387 mm)
Maximum Spool Capacity	12 in (305 mm)
Cooling Method	Air-Cooled (A Models) Or Water-Cooled (W Models)
Weight (Feeder With Gun)	Models With 15 ft (4.6 m) Cable Assembly Net: 56 lb (25 kg); Ship: 58 lb (26 kg) Models With 30 ft (9.1 m) Cable Assembly Net: 63 lb (29 kg); Ship: 65 lb (30 kg)

3-2. Gun Specifications

Specification	Description
Input Voltage	30 Volts DC
Duty Cycle (Air-Cooled Models)	At 200 Amperes, 100% Using Argon Or Argon Mixture Shielding Gas At 250 Amperes, 60% Using Argon Or Argon Mixture Shielding Gas (See Section 3-3)
Duty Cycle (Water-Cooled Models)	At 400 Amperes, 100% Using Argon Or Argon Mixture Shielding Gas (See Section 3-3)
Wire Size Range	.030 Thru 1/16 in (0.8 Thru 1.6 mm) Aluminum Wire .030 Thru .045 in (0.8 Thru 1.1 mm) Hard Or Cored Wire

3-3. Duty Cycle And Overheating





Duty Cycle is percentage of 10 minutes that unit can weld at rated load without overheating.

▲ Exceeding duty cycle can damage unit and void warranty.

Air-Cooled Models

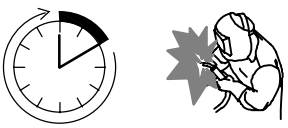
100% Duty Cycle At 200 Amperes Using Argon



Continuous Welding

60% Duty Cycle At 250 Amperes Using Argon

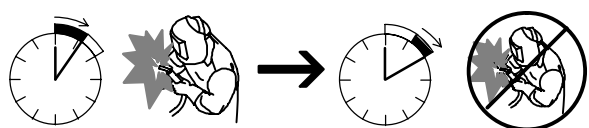

6 Minutes Welding 4 Minutes Resting

Water-Cooled Models

100% Duty Cycle At 400 Amperes Using Argon



Continuous Welding

SECTION 4 – INSTALLATION

NOTE

Be sure that contact tip, liner, and drive rolls are correct for wire size and type. See Section 5 to change parts as needed. See Section 7 for list of other available contact tips.

Review Section 4-1 through Section 4-4 to determine how equipment will be connected. Air-cooled models are shown in Section 4-1 through Section 4-4. For water-cooled models, supplied water hoses must be connected from wire feeder to coolant supply.

Read entire Section 4 before installing equipment.

4-1. Connections With A CC, CV Or CC/CV Voltage Welding Power Source Having A 14-Socket Receptacle

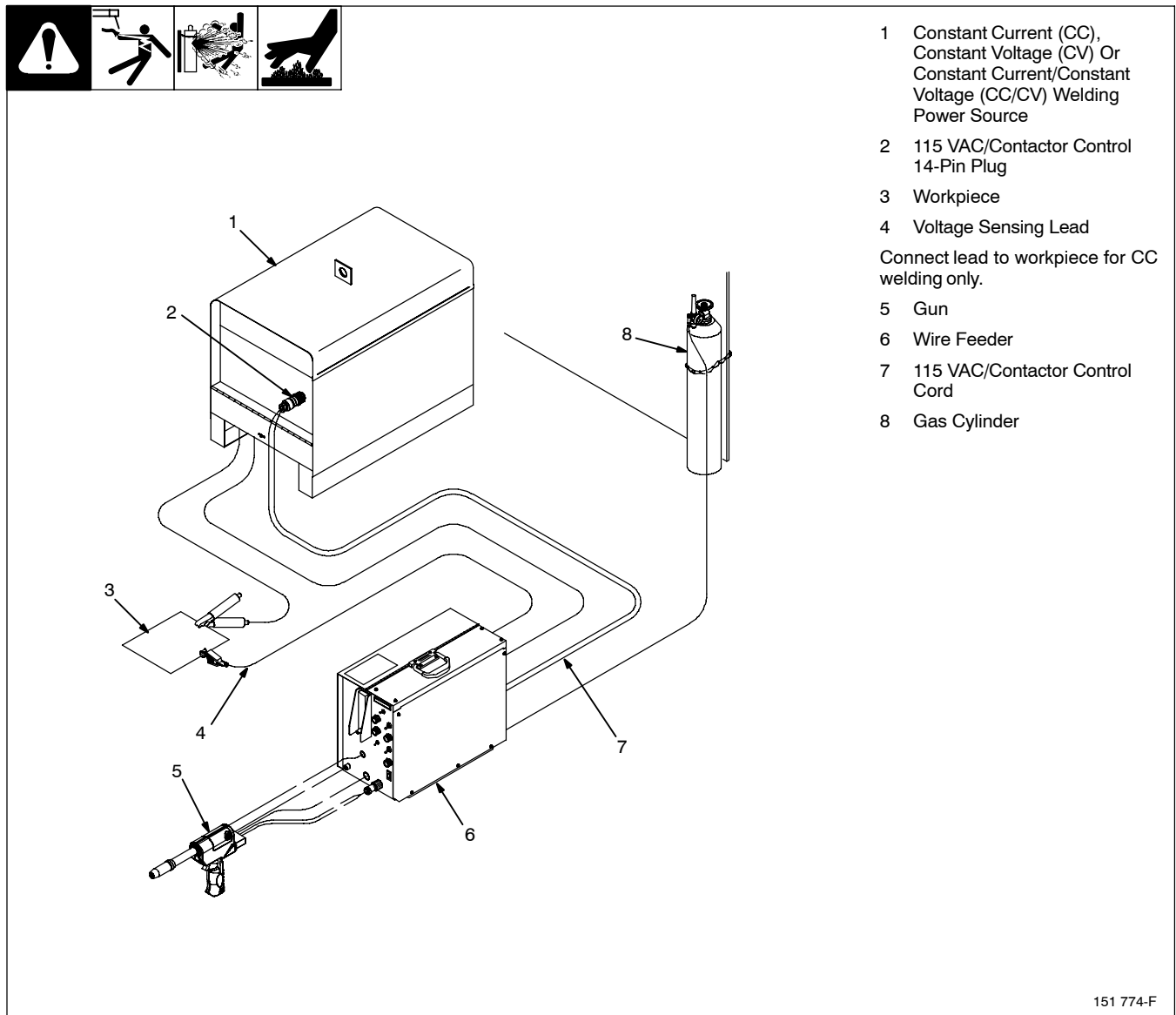

4-2. Connections With A CV Welding Power Source Having Separate 115 VAC And Contactor Control Receptacles

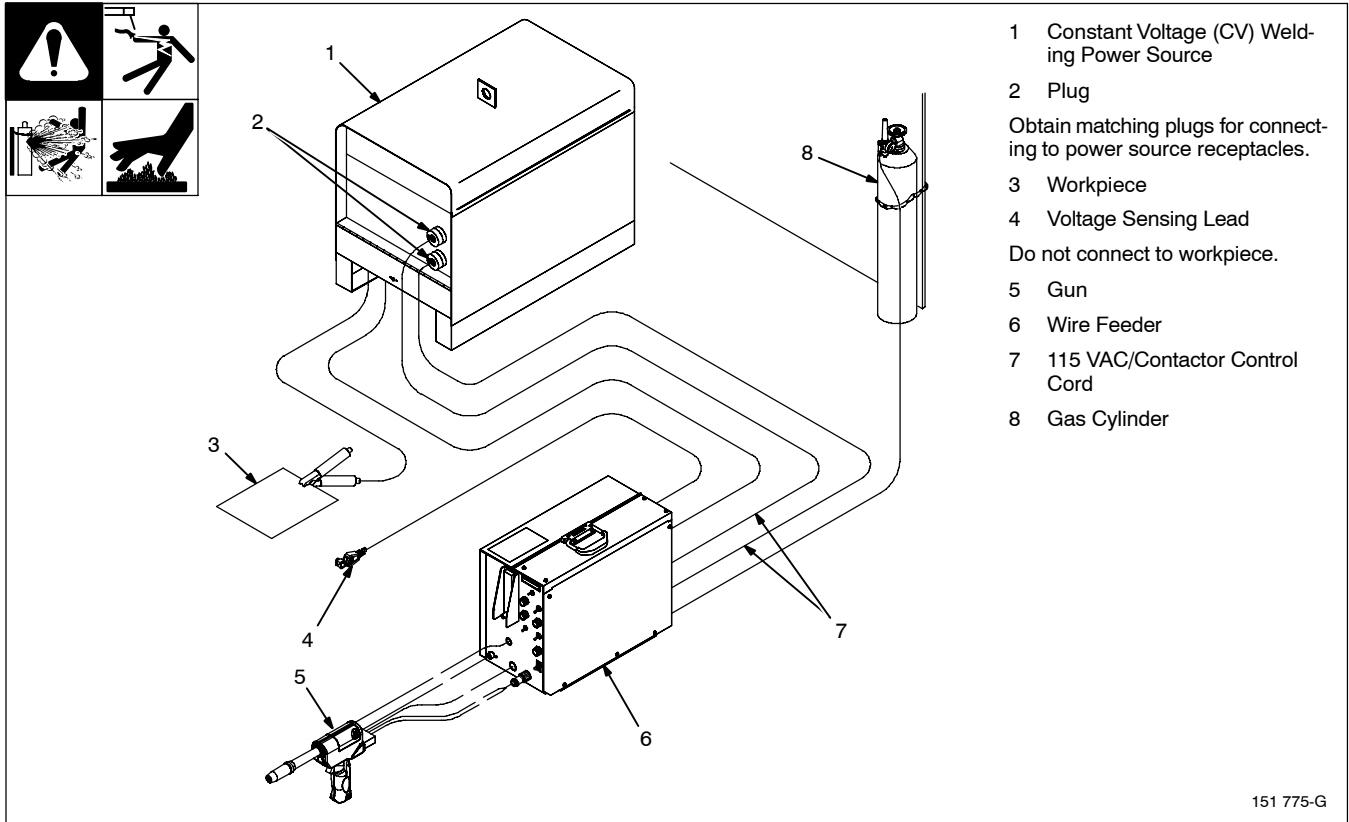

4-3. Connections With A CC Welding Power Source Having A Contactor Control Receptacle

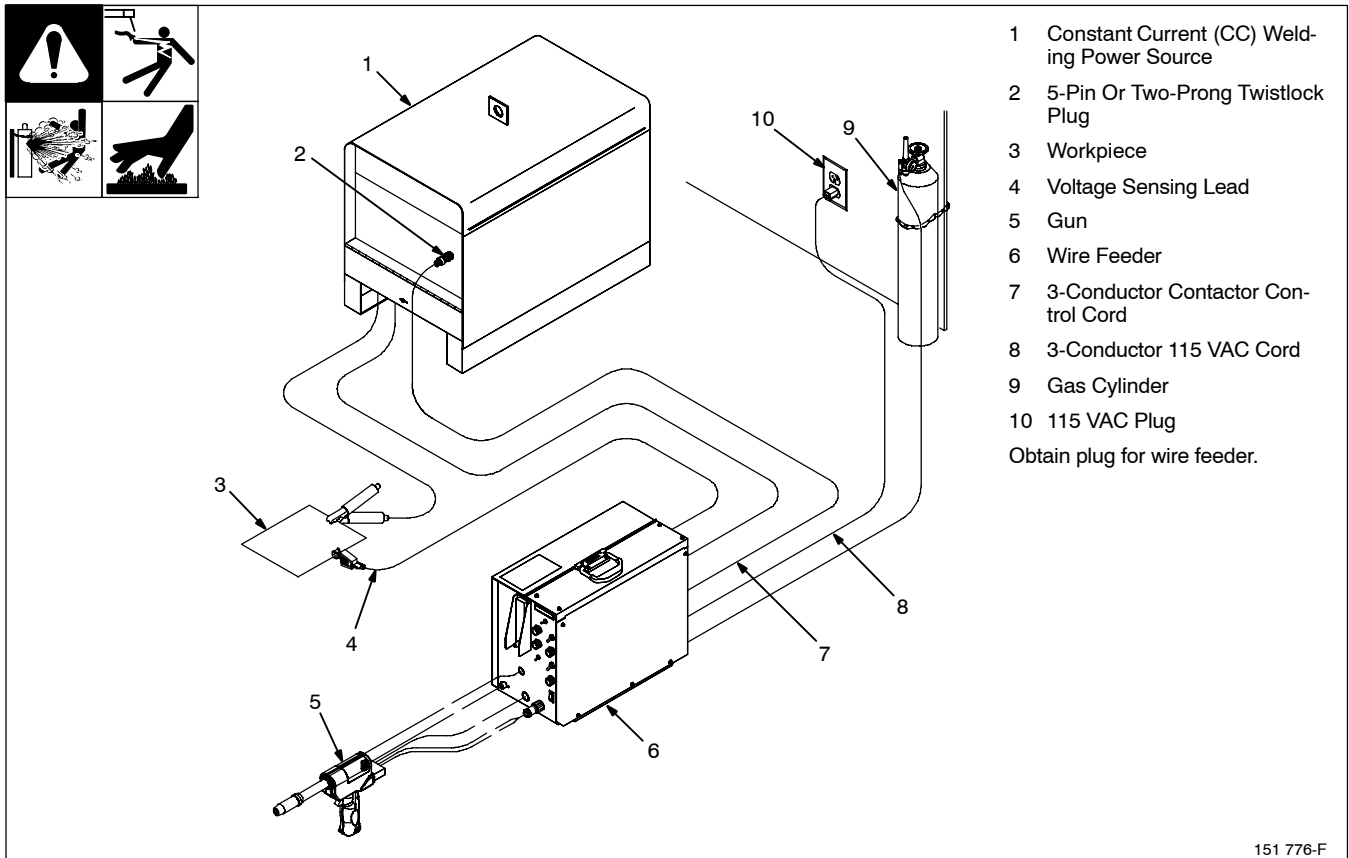

4-4. Connections With A CC Welding Power Source And A 115 VAC/12 VDC Secondary Contactor

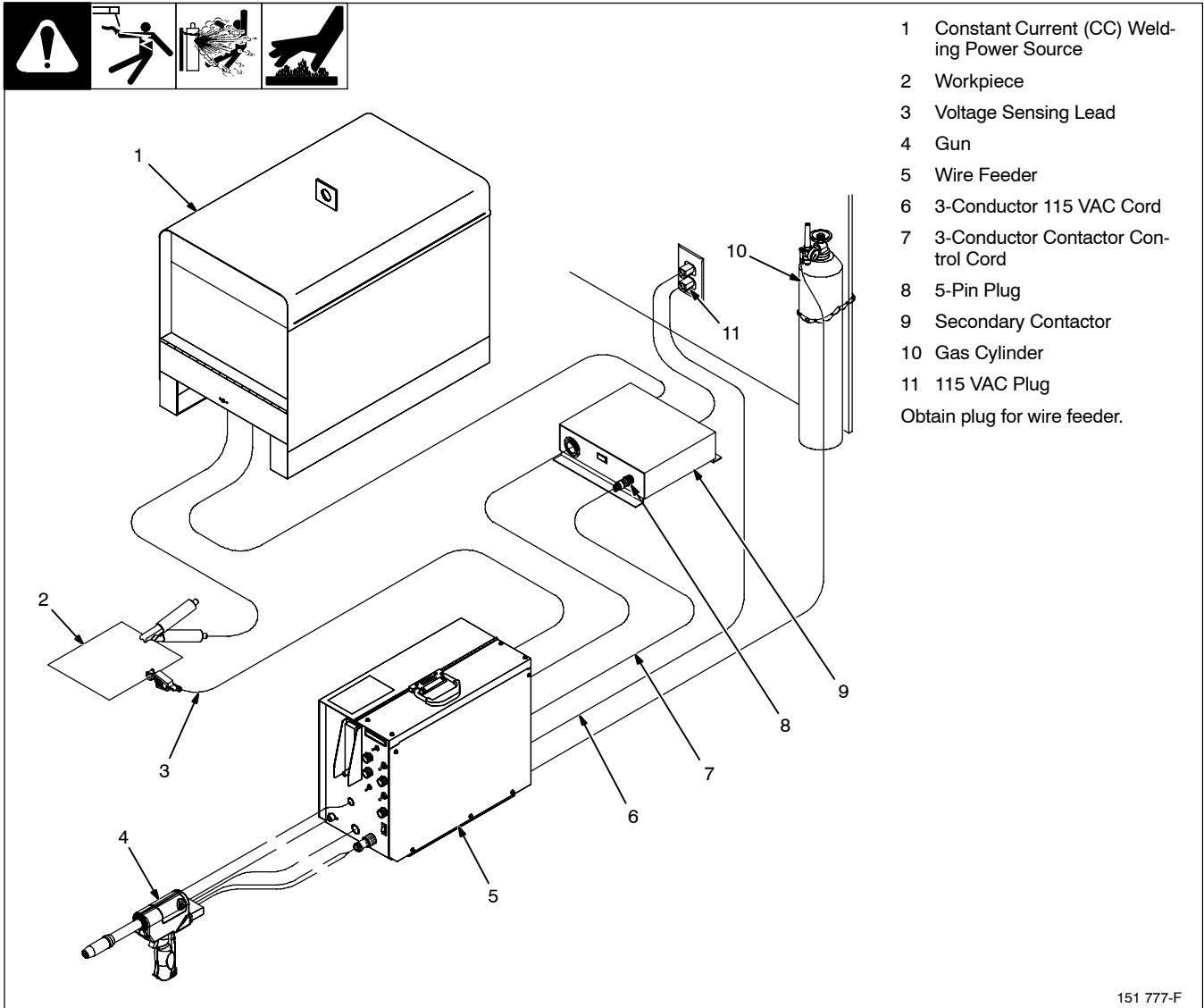

4-5. Removing Top Cover Of Pistol Grip Gun

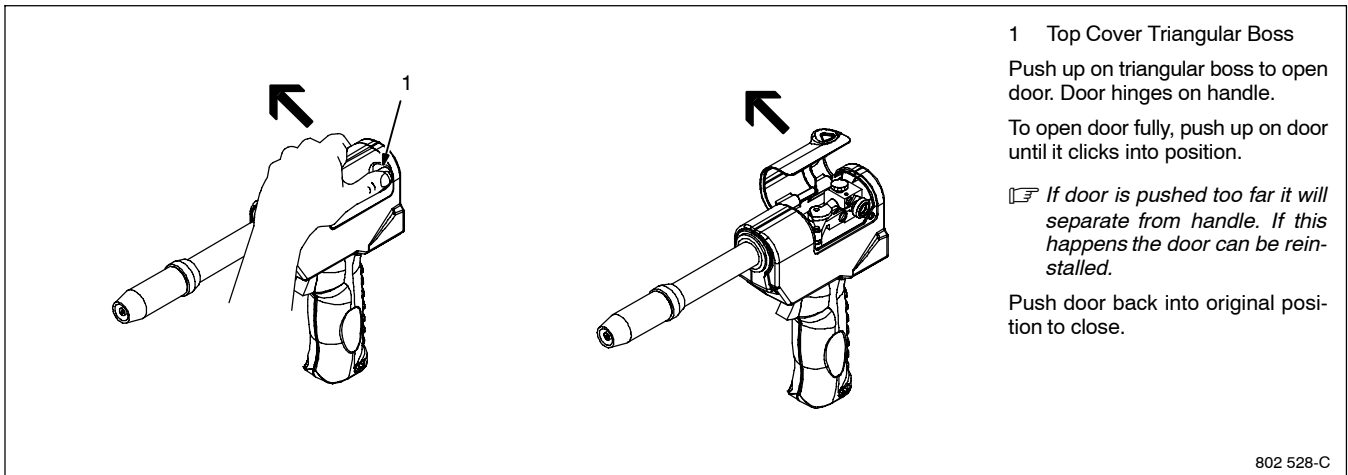

4-6. Air-Cooled Gun Connections

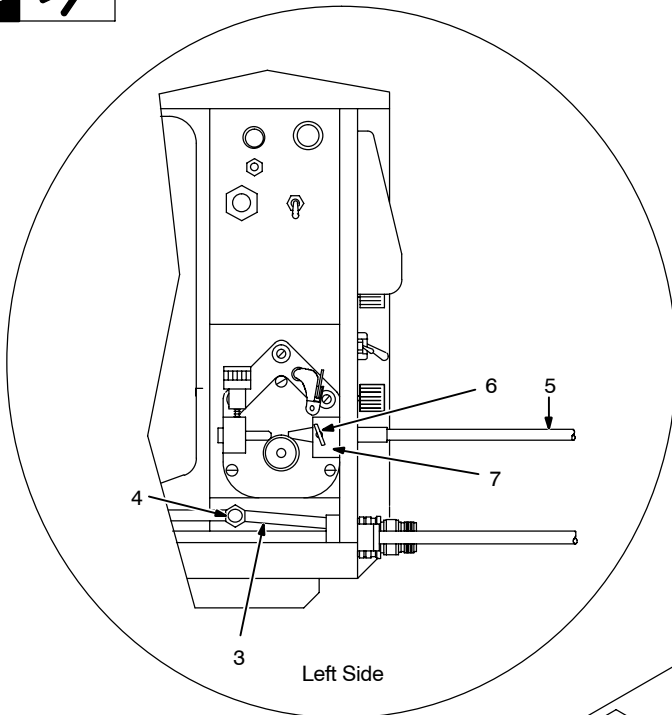

1 Gun Control Cable

Insert plug into Gun Control receptacle, and tighten threaded collar.

2 Gas Hose

Connect to Gas fitting on feeder.

3 Weld Cable

4 Weld Cable Terminal In Feeder

Connect gun weld cable to weld cable terminal in feeder.

5 Wire Conduit

6 Thumbscrew

7 Wire Conduit Block

8 Strain Relief

For guns that have wire conduits with replaceable liners, the strain relief will need to be removed from the control box.

Loosen thumbscrew, and insert conduit through wire opening until it bottoms against block. Trim liner if necessary, as close to the rolls as possible. Tighten thumbscrew. Close and latch door.

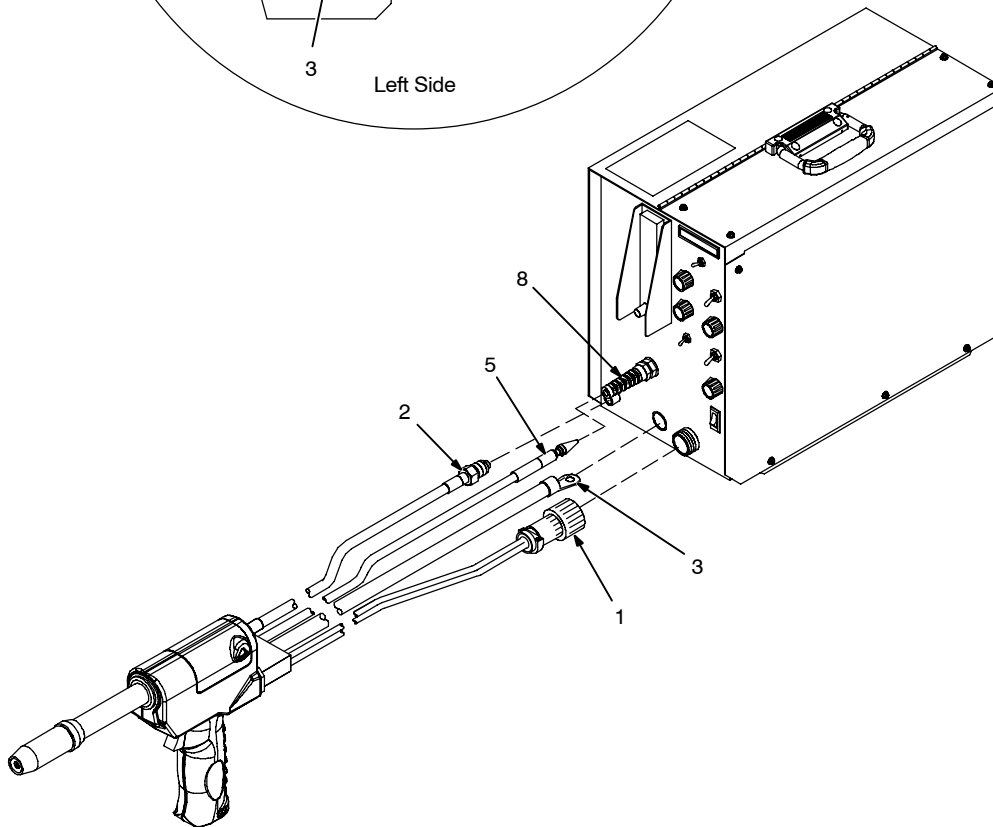

Tools Needed:



145 432-C / Ref. 802 536-E / Ref. 151 778-B

4-7. Water-Cooled Gun Connections

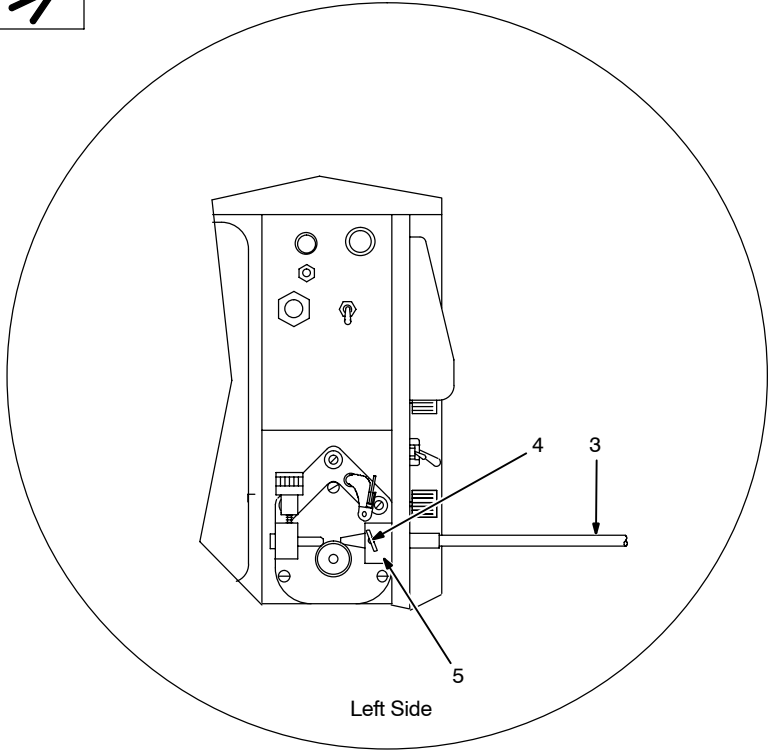

- 1 Gas Hose
Connect to Gas fitting on feeder.
- 2 Water Hose
Connect to water to gun fitting on feeder (left-hand threads).
- 3 Wire Conduit
- 4 Thumbscrew
- 5 Wire Conduit Block
Loosen thumbscrew, and insert conduit through Wire opening until it bottoms against block. Trim liner if necessary, as close to the rolls as possible. Tighten thumbscrew.
- 6 Gun Control Cable
Insert plug into gun control receptacle, and tighten threaded collar.
- 7 Strain Relief
Remove strain relief as shown.
- 8 Power/Water Cable
- 9 Strain Relief

For guns that have wire conduits with replaceable liners, the strain relief will need to be removed from the control box.

Route cable through strain relief and connect to weld/water from gun outlet on feeder. Reinstall strain relief. Close and latch door.

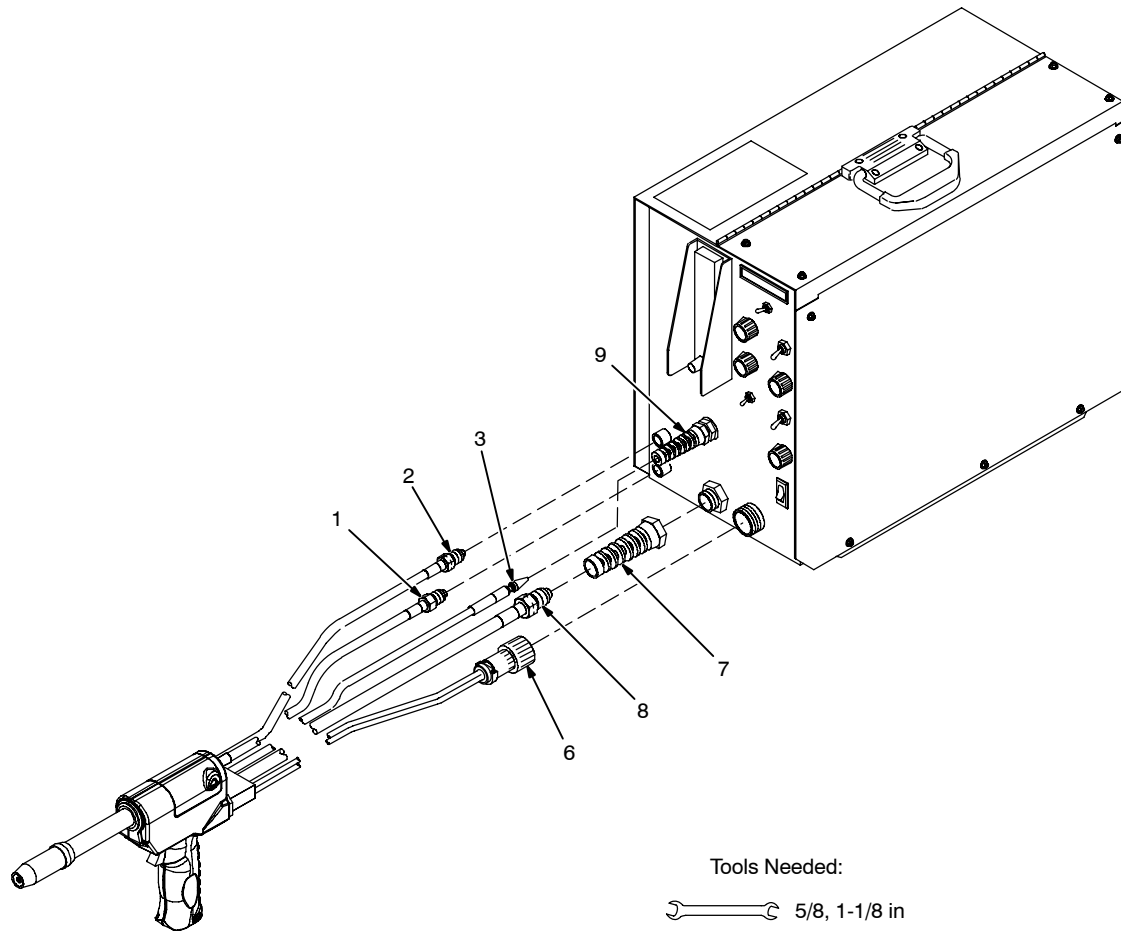

Tools Needed:

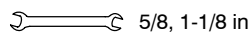

Ref. 802 536-E / Ref. 151 778-B / 152 456-A

4-8. Air-Cooled Feeder Connections

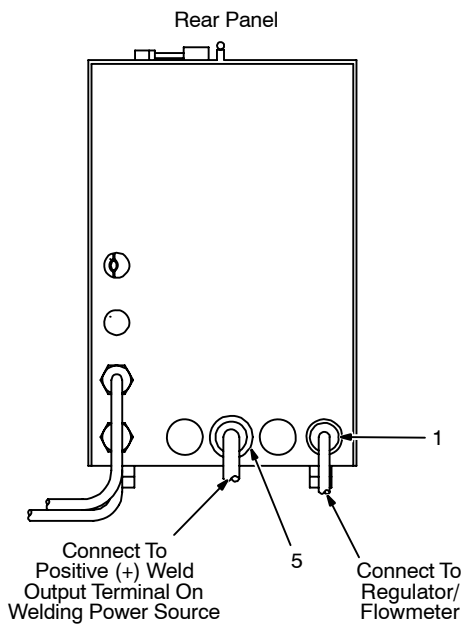
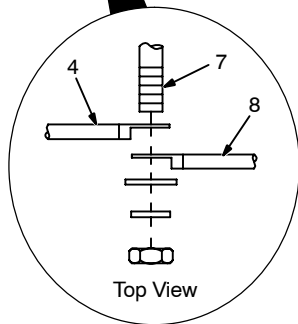
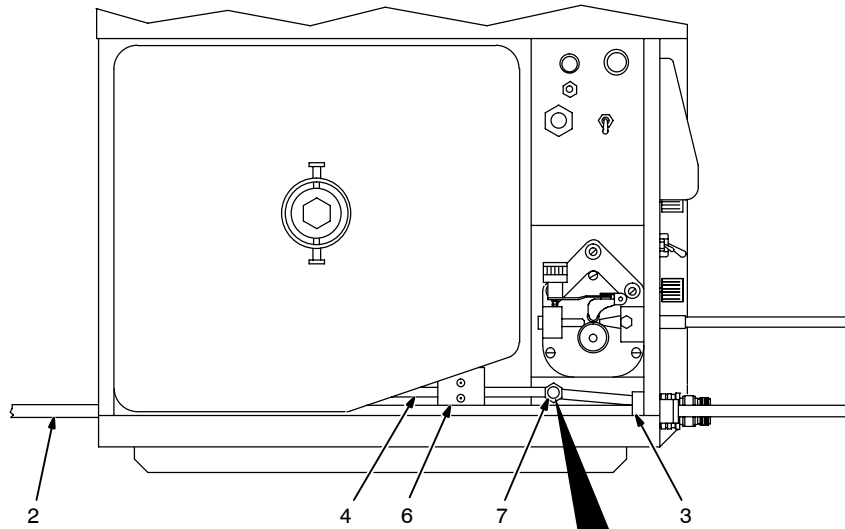

- 1 Gas Hose Grommet
- 2 10 ft (3 m) Gas Hose
- 3 Rear Of Gas Fitting

Route one end of gas hose through grommet, and connect hose to rear of Gas fitting in feeder. Connect remaining end of hose to regulator/flowmeter

- 4 Weld Cable To Welding Power Source

Select and prepare weld cable according to welding power source manual.

- 5 Weld Cable Grommet
- 6 Current Sensing (Reed) Relay
- 7 Weld Cable Terminal In Feeder

Route one end of weld cable through grommet, through reed relay, and connect to weld cable terminal in feeder. Connect remaining end of cable to positive (+) weld output terminal on welding power source.

- 8 Gun Weld Cable

Be sure that terminal of welding power source weld cable is in direct contact with terminal from gun weld cable. Close and latch door.

Tools Needed:



Ref. 151 771-A

4-9. Water-Cooled Feeder Connections

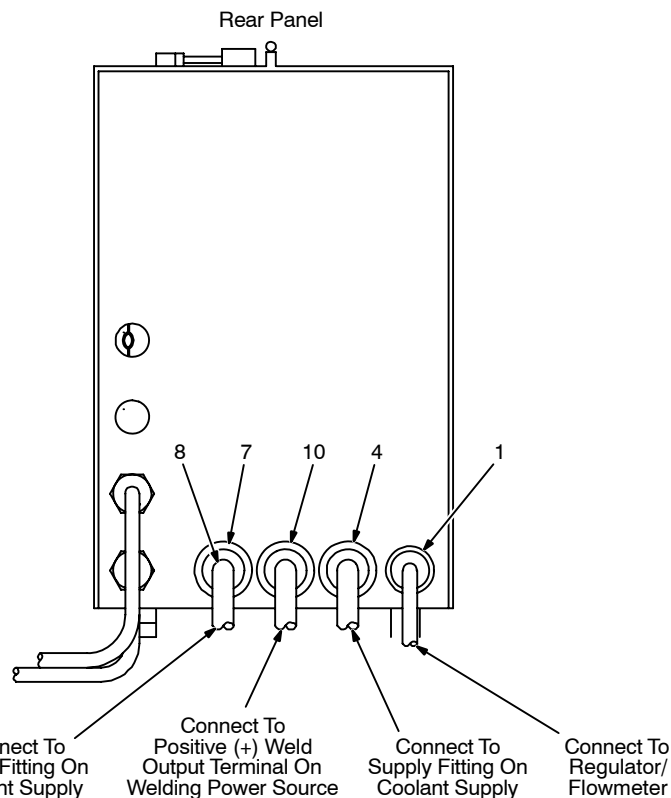
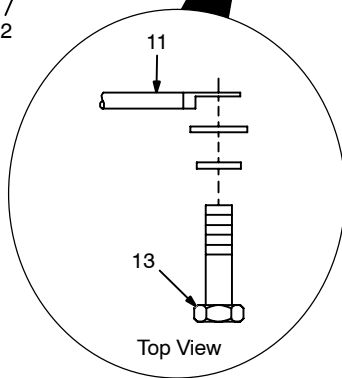
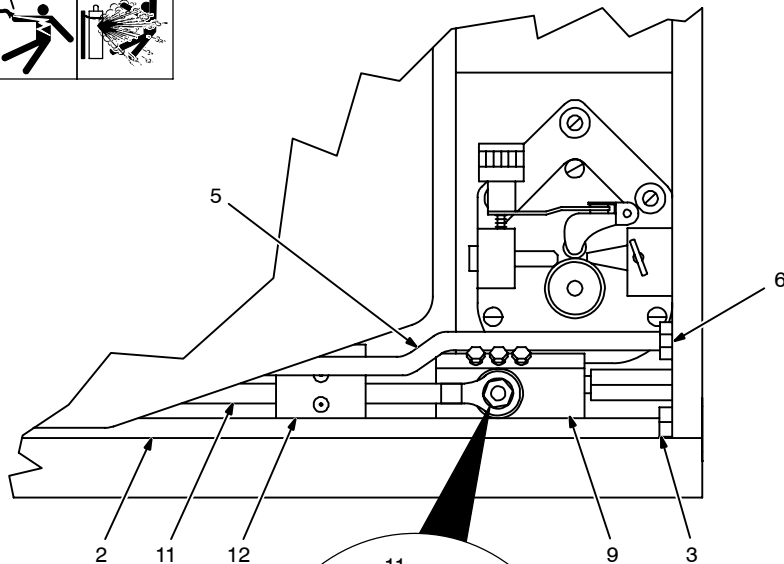

Obtain coolant supply.

- 1 Gas Hose Grommet
- 2 10 ft (3 m) Gas Hose
- 3 Rear Of Gas Fitting

Route one end of gas hose through grommet, and connect hose to rear of Gas fitting in feeder. Connect remaining end of hose to regulator/flowmeter

- 4 Coolant Supply Hose Grommet
- 5 10 ft (3 m) Water Supply Hose With 5/8 in Adapter Fitting
- 6 Rear Of Water Fitting (Left-Hand Threads)

Remove 5/8 in adapter fitting from hose. Route one end of a water hose through grommet, and connect to rear of Water To Gun fitting in feeder. Connect remaining end to supply fitting on coolant supply.

- 7 Coolant Return Hose Grommet
- 8 10 ft (3 m) Water Return Hose
- 9 Connection Block (Left-Hand Threads)

Route one end of remaining water hose through grommet, and connect to rear of connection block (not shown). Connect remaining end of hose to return fitting on coolant supply.

- 10 Weld Cable Grommet
- 11 Weld Cable To Welding Power Source

Select and prepare weld cable according to welding power source manual.

- 12 Current Sensing (Reed) Relay
- 13 Weld Cable Screw In Feeder

Route one end of weld cable through grommet, through reed relay, and connect to block in feeder using hardware shown. Connect remaining end of cable to positive (+) weld output terminal on welding power source.

Close and latch door.

Tools Needed:

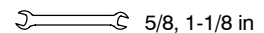

Ref. 152 431-A

4-10. Voltage Sensing Lead Connections

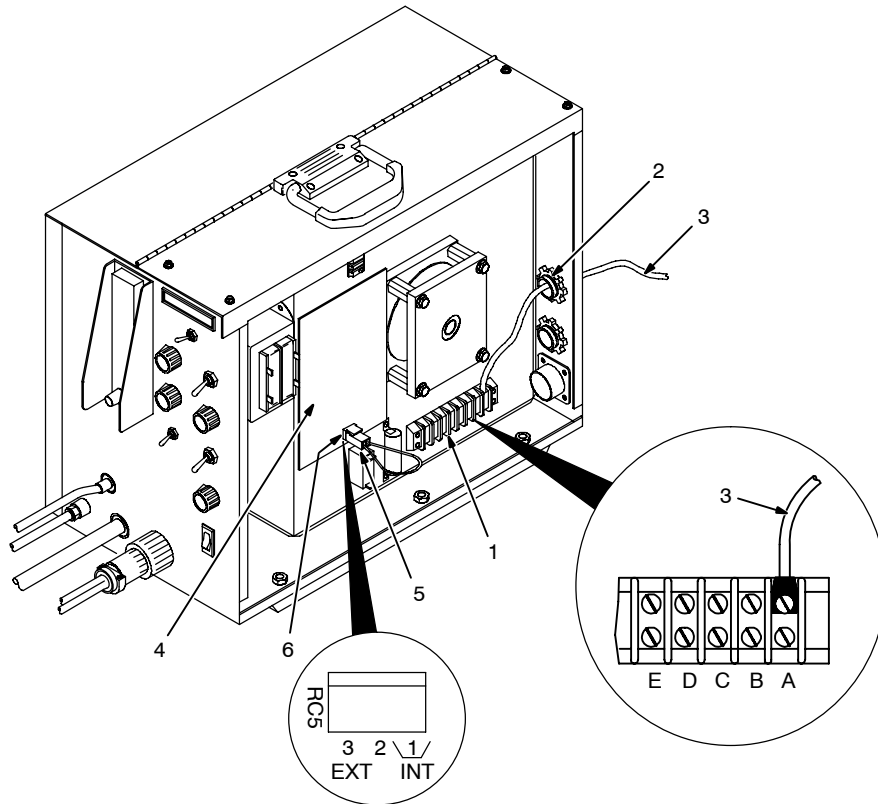

Unit is factory set for constant voltage (CV) welding. To set unit for constant current (CC) welding, proceed as follows:

- 1 Terminal Strip 2T
- 2 Strain Relief

Loosen screws of strain relief.

- 3 Voltage Sensing Lead

Route ring terminal end of lead through strain relief, and connect ring terminal to terminal A of terminal strip 2T. Tighten screws on strain relief.

- 4 Motor Speed Control Board PC1

- 5 Jumper Plug

- 6 Receptacle RC5

For constant voltage (CV) welding, place jumper plug in INT. position. Do not connect voltage sensing lead clamp to workpiece.

For constant current (CC) welding, place plug in EXT. position. Connect clamp end of voltage sensing lead to workpiece.

Reinstall right side panel.

Tools Needed:

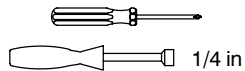

Ref. 151 772-B

4-11. 115 VAC/Contactor Control Plug Information

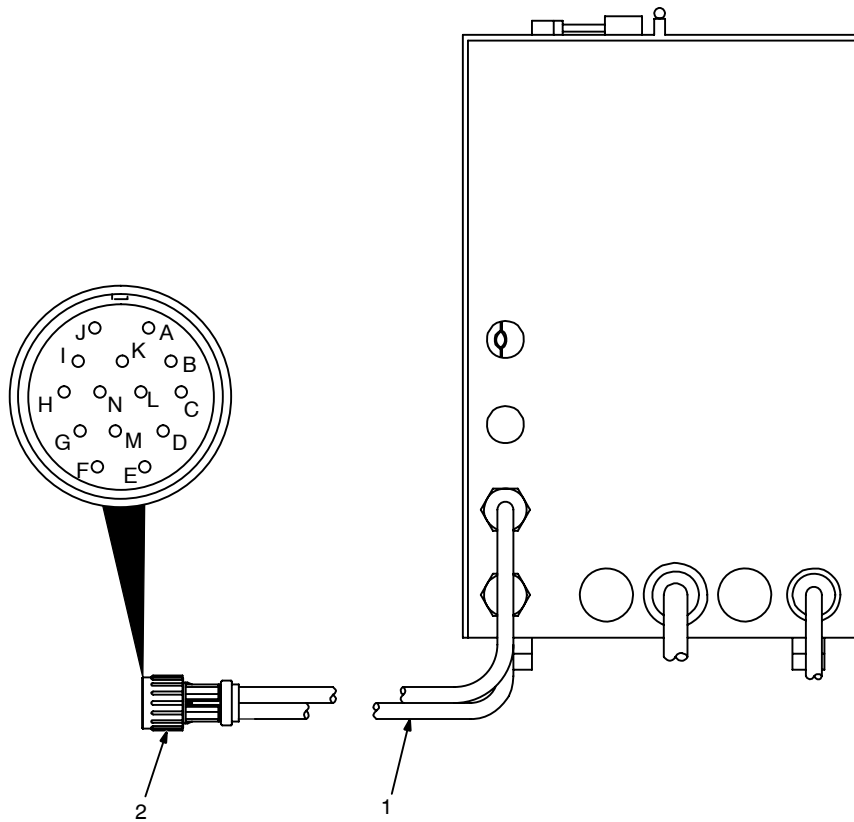

- 1 Interconnecting Cord
- 2 115 VAC/Contactor Control Plug PLG5

If CC or CC/CV welding power source is equipped with matching 14-socket receptacle, insert plug, and tighten threaded collar. Proceed to Section 4-13.

If plug PLG5 will not connect to CC welding power source receptacle, use the following pin information and Section 4-12 to replace PLG5 with a suitable plug.

	Pin*	Pin Information
Remote Contactor	A, B	Contact closure to A completes contactor control circuit.
	I	115 volts ac.
	J	Contact closure to I completes 115 volts ac contactor control circuit.
	G	Circuit common for 115 volts ac circuit.
Remote Voltage Control	C	+10 volts dc output to remote control.
	D	Remote control circuit common.
	E	0 to +10 volts dc input command signal from remote control.
	K	Chassis common.

*The remaining pins are not used.

Ref. S-0004-A / Ref. 151 772

4-12. Replacing 115 VAC/Contactor Control Plug With Customer-Supplied 5-Pin Or Twistlock Plug

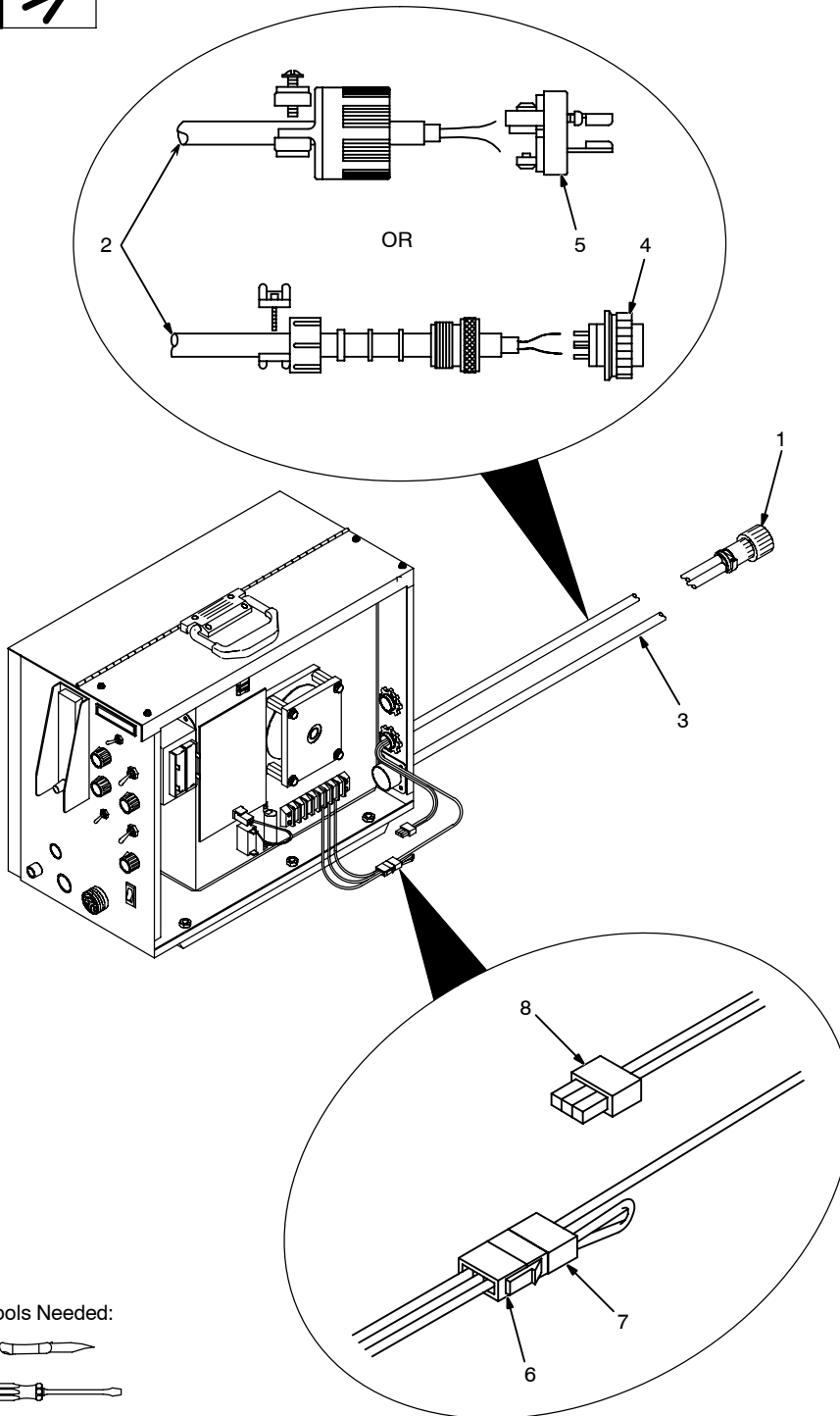

1 115 VAC/Contactor Control Plug PLG5

2 Contactor Control Cord

3 115 VAC Cord

Find and label cords by following leads to back of PLG5:

Contactor control cord connects to pins A & B of PLG5

115 VAC cord connects to pin J of PLG5.

Cut off plug PLG5.

4 5-Pin Plug

5 Two-Prong Twistlock Plug

For connections shown in Figure 3-3 or Figure 3-4, install 5-pin or twistlock plug onto contactor control cord.

For Figure 3-2 connection, obtain plug to match contactor control receptacle on welding power source, and install plug onto contactor control cord.

Obtain 115 VAC plug and connect to 115 VAC cord as follows:

green lead to ground

white lead to 115 VAC common

black lead to 115 VAC hot.

6 Plug PLG50

7 Plug PLG51

8 Plug PLG52

Unit shipped with PLG50 connected to PLG51 to provide 115 VAC for contactor.

If contact closure needed for contactor, connect PLG50 to PLG52.

Tools Needed:

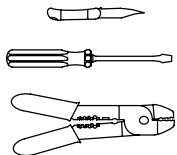

151 773-C

4-13. Installing Wire Spool

Turn Off wire feeder and welding power source.

- 1 Wire Spool
- 2 Top Cover
- 3 Pressure Roll Assembly
- 4 Gun Contact Tip

If wire spool is being replaced, open pressure roll assembly in gun, and cut welding wire off at contact tip.

For welding power sources without contactor, retract wire onto spool.

For welding power sources with a contactor, energize power source, turn On feeder, press Brake Release button (see Section 5-11), and retract wire onto spool.

Close gun pressure roll assembly and reinstall top cover.

- 5 Hub
- 6 Hub Pin
- 7 Compression Spring (Optional For 8 in Spool)
- 8 Retaining Ring

Slide spool onto hub so wire feeds off bottom. Turn spool until hub pin fits hole in back of spool. Reinstall retaining ring.

Thread welding wire (see Section 4-14). Close and latch door or go on to Section 4-14.

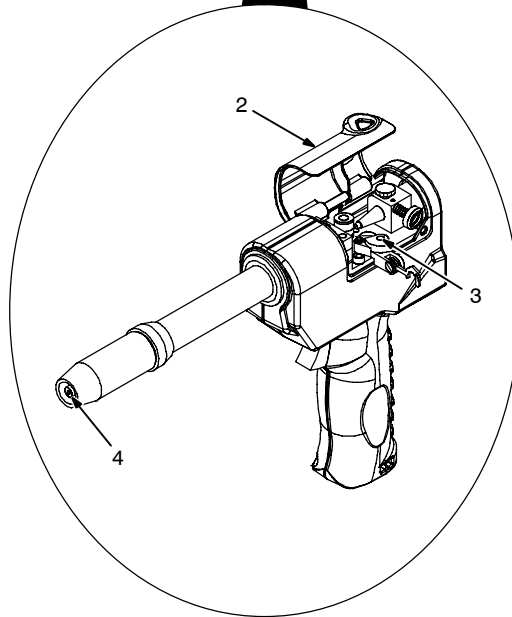
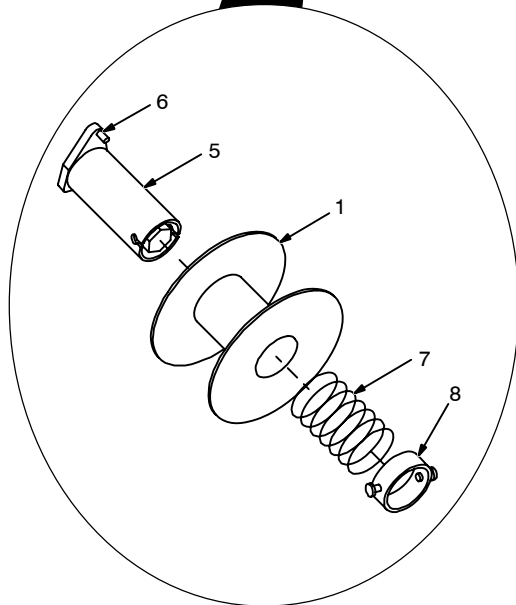
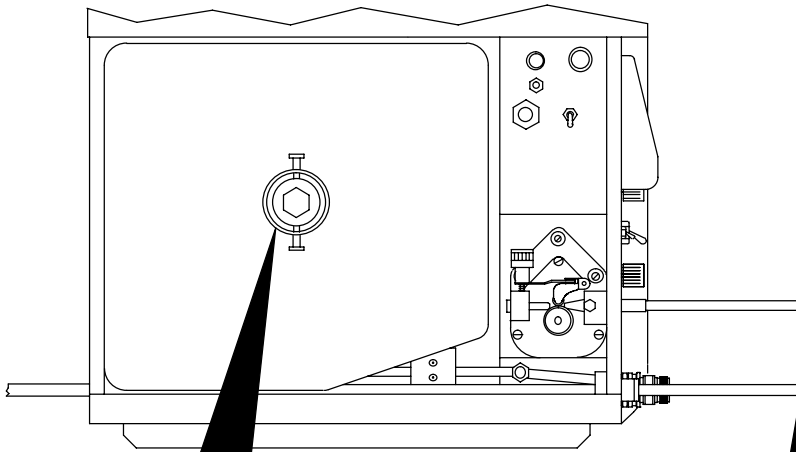

Tools Needed:

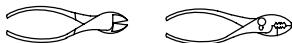

Ref. 151 771-A / Ref. 072 573-B / Ref. 151 599-F

4-14. Threading Welding Wire Through Feeder

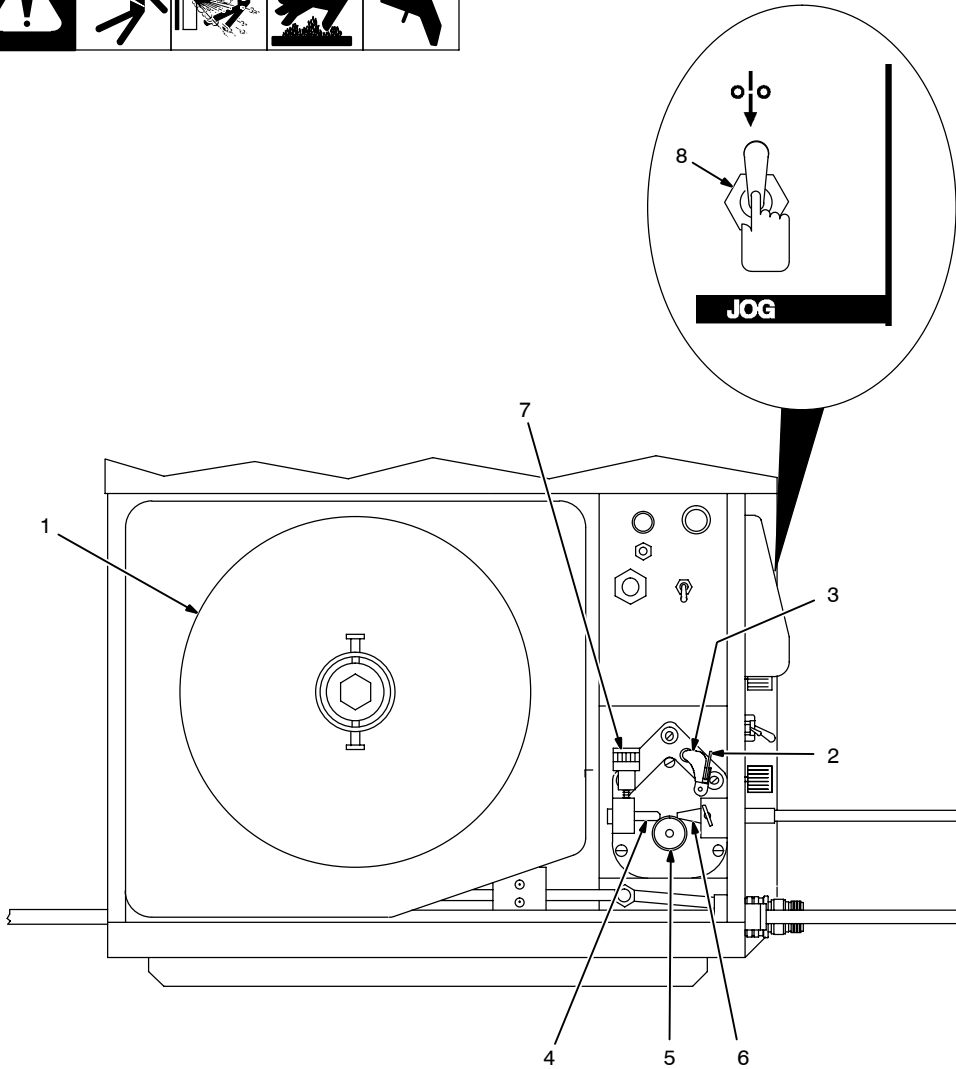
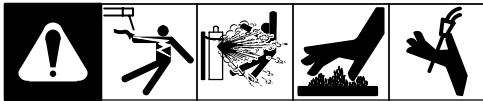

1 Wire Spool

Loosen wire from spool, cut off bent wire, and pull 6 in (150 mm) of wire off spool.

2 Tension Arm

3 Mounting Arm

To open pressure roll assembly, open tension arm and lift mounting arm.

4 Wire Inlet Guide

5 Drive Roll

6 Wire Conduit Fitting

Thread wire through wire inlet guide, along drive roll groove, and into fitting.

Close and secure pressure roll assembly.

7 Tension Thumbnut

8 Jog Switch

Turn On wire feeder. For proper adjustment, loosen thumbnut until drive roll slips when Jog switch is pushed up. Grasp spool with one hand, and turn thumbnut clockwise until motor stalls when Jog switch is pushed up.

Feed welding wire through gun (see Section 4-15). Turn Off wire feeder. Close and latch door.

Tools Needed:



151 778-B / Ref. 176 700-A

4-15. Threading Welding Wire Through Gun

1 Pressure Roll Assembly
Lift arm and open pressure roll assembly.

2 Wire Conduit
Lay wire conduit out straight.

3 Jog Switch
Push Jog switch up to feed wire through wire conduit.

4 Drive Roll
For wire sizes .035 in (0.9 mm) and smaller use small groove, and .047 in (1.2 mm) and 1/16 in (1.6 mm) use large groove.

5 Contact Tip
Manually thread wire along drive roll groove and out contact tip 2 in (51 mm). Close pressure roll assembly.

6 Tension Thumbnut
7 Pressure Adjustment Knob
8 Final Pressure Adjustment
Turn On feeder and check drive roll pressure by feeding wire against a piece of wood or concrete surface; wire should feed steadily without slipping. If necessary, adjust pressure adjustment knob in gun.
Turn Off feeder and welding power source. Reinstall gun cover. Close and latch feeder door.

151 599-F / 151 666-E / Ref. 176 700-A / Ref. S-0651

4-16. Coolant Guidelines

CAUTION

INCORRECT COOLANT OR COOLANT CONTAINING STOP-LEAK ADDITIVES can corrode and/or plug gun/feeder cooling passages.

- Use only a mix of 50% distilled water and 50% high quality automotive antifreeze as proper coolant for this product.
- Do not use antifreeze containing stop-leak additives.
- Use of other coolant voids warranty.

Follow these guidelines to decrease corrosion in gun/feeder and cooling system:

1 Coolant
Mix distilled water and high quality automotive antifreeze. Use anti-freeze which does not contain stop-leak additives.
Use of other coolant voids warranty.

2 Coolant System Tank
3 Changing Coolant
Change coolant only if dirty.
Add coolant to keep level full.

4 Tighten Connections
Keep gun connections tight. S-0760

4-17. Adjusting Wire Feed Starting Speed

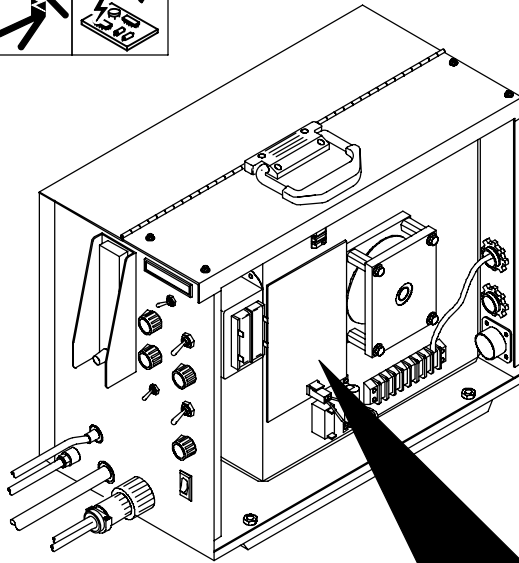

To adjust wire feed starting speed, proceed as follows:

Turn Off wire feeder and welding power source. Open right side panel.

- 1 Motor Speed Control Board PC1
- 2 Motor Start Control Potentiometer R70

Turn potentiometer clockwise to increase time it takes the motor to ramp up to speed. Remove protective white rubber cap before making adjustment. Adjust potentiometer using a small nonconductive screwdriver.

Close side door.

Top Of PC1

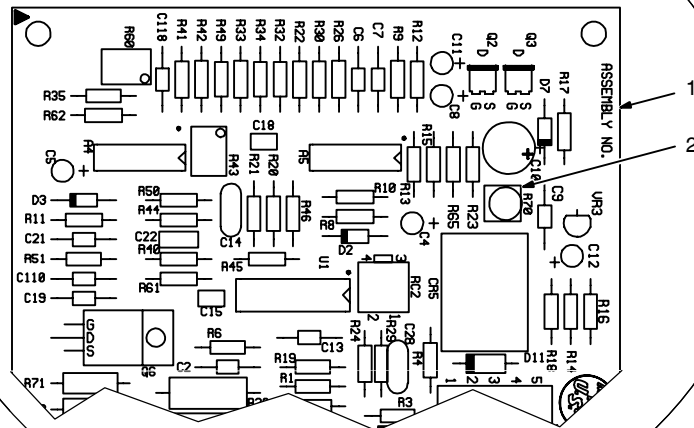

Tools Needed:

Nonconductive

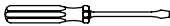

1/4 in

Ref. 151 772-B / Ref. 142 054-B

SECTION 5 – OPERATION



5-1. Front Panel Controls Of Feeder (Air-Cooled Model Shown)

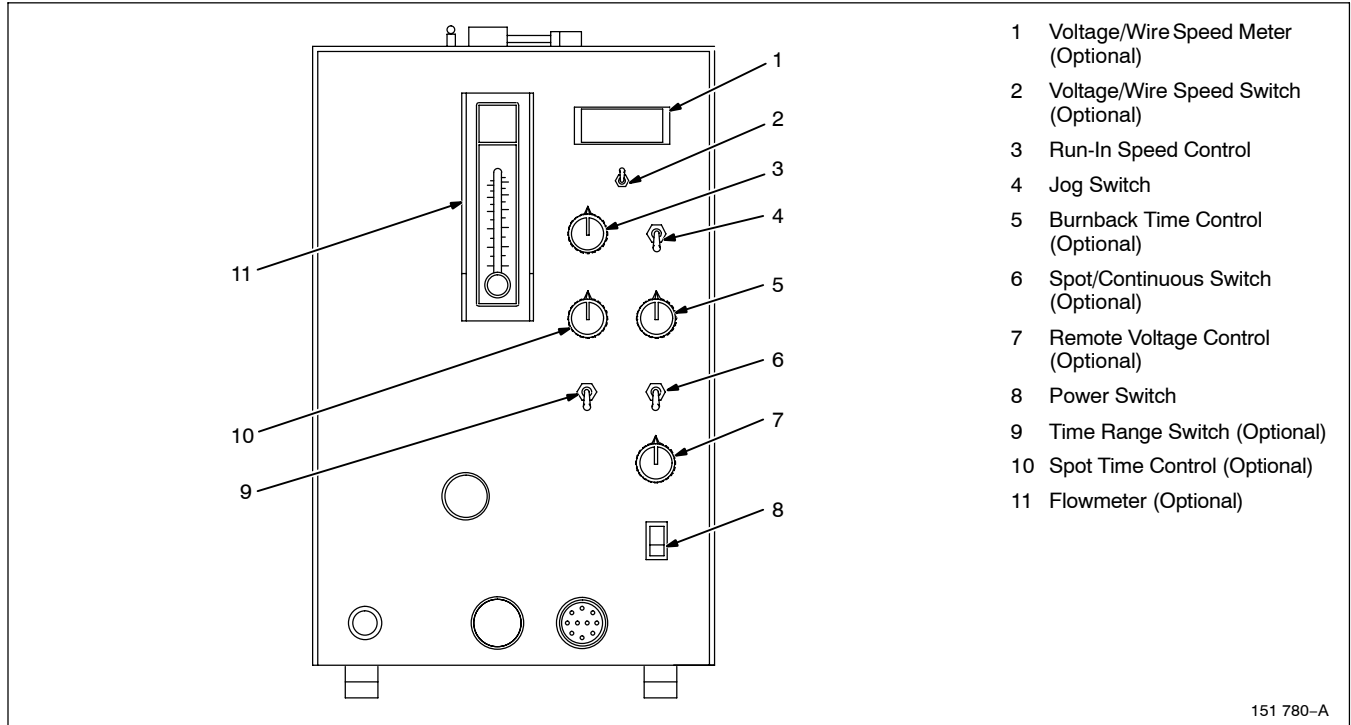

5-2. Safety Equipment

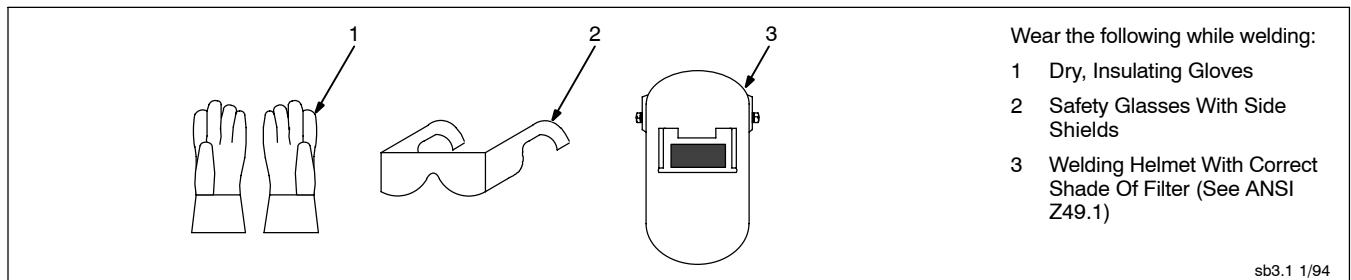

5-3. Work And Voltage Sensing Cable Clamps

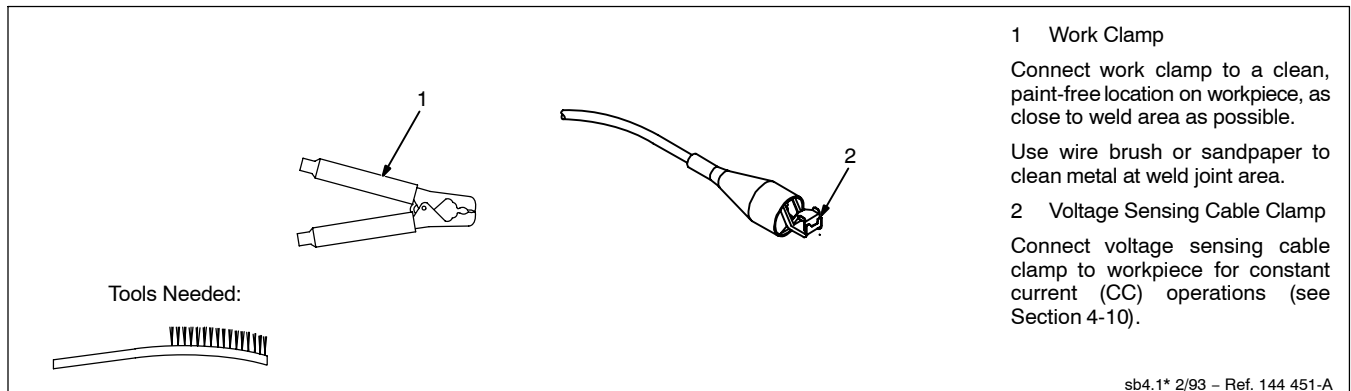

5-4. Run-In Speed Control

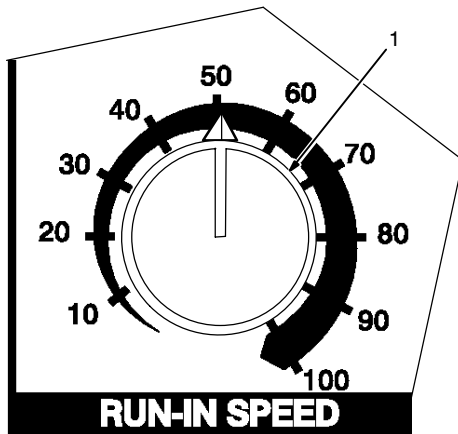

1 Run-In Speed Control

Use control to set wire feed speed before arc initiation.

After arc initiation, wire feed speed is controlled by the Wire Speed Control on the welding gun (see Section 5-12).

The scale around the control is percent of full range, not wire speed. As a general rule, set run-in speed lower than welding wire feed speed.

Set control at 0 (zero) for scratch start.

Ref. 176 700-A

5-5. Jog Switch

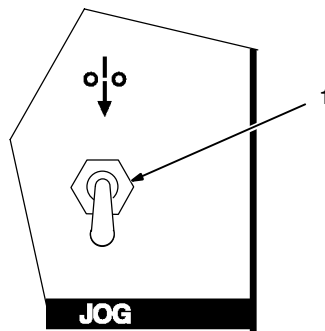

1 Jog Switch

Use switch to energize drive motors in feeder and gun without energizing welding power source contactor. When switch is held up in Jog position, wire speed is set by Wire Speed Control on gun.

5-6. Voltage/Wire Speed Switch And Meter (Optional)

 Volt sensing lead must be connected to workpiece for meters to operate.

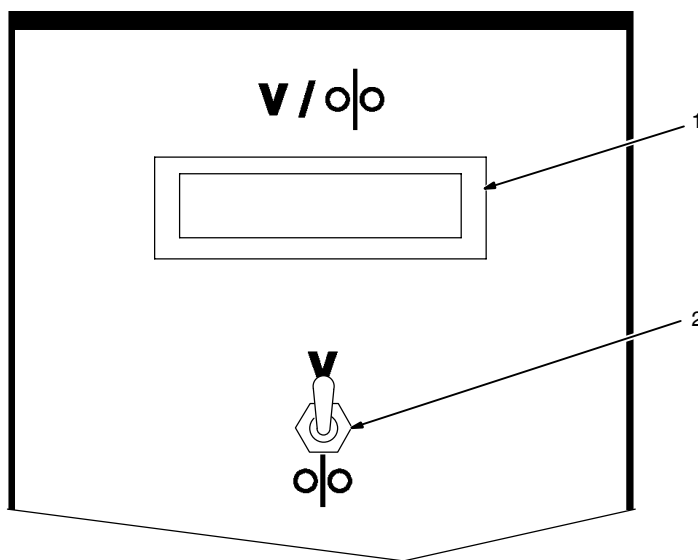

1 Voltage/Wire Speed Meter

2 Voltage/Wire Speed Switch

When switch is in Voltage position, and operator is welding, meter displays arc voltage. Cable resistance and poor connections may cause displayed voltage to vary slightly from actual voltage at welding arc.

When switch is in Wire Speed position and operator is welding, meter displays preset wire speed in inches per minute. This wire speed is set by Wire Speed Control on the gun.

During run-in portion of weld cycle, meter displays run-in speed as selected on Run-In Speed control on feeder (see Section 5-4).

When welding Direct Current Electrode Negative (DCEN), meter does not display accurate output voltages; however, meter displays accurate wire speed values.

5-7. Spot Controls (Optional)

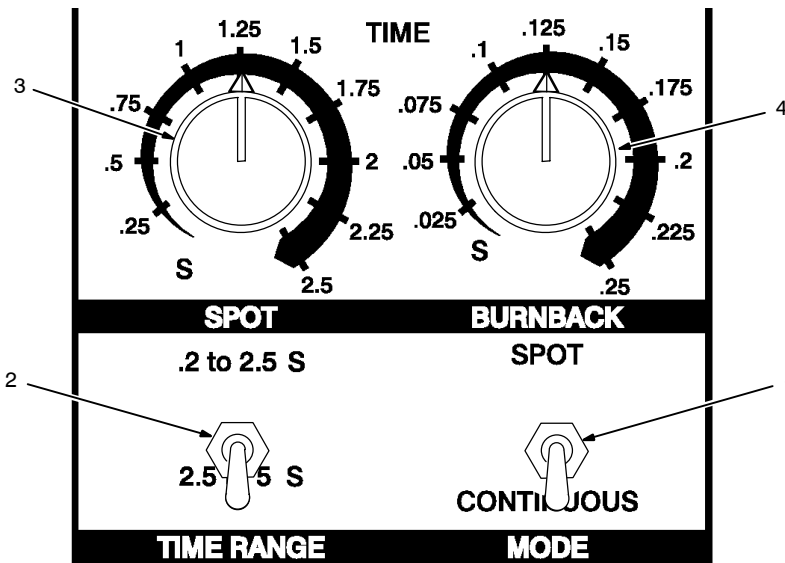

1 Spot/Continuous Switch

Use switch to select either an untimed continuous weld cycle or a timed spot weld cycle. Both weld cycles consist of the following steps: run-in, weld (untimed or spot time), and burnback.

2 Time Range Switch

Use switch to select spot weld time range.

3 Spot Time Control

Use control to set spot weld time. Welding wire feeds at speed selected on the gun Wire Speed Control. Spot time starts at arc initiation.

The scale around the control is marked in seconds.

4 Burnback Time Control

Use control to adjust time (up to 0.25 seconds) that the welding wire is electrically energized after the wire stops feeding.

If welding wire sticks in the weld puddle, increase burnback time. If wire burns back into the gun contact tip, decrease burnback time.

The scale around the control is marked in fractions of a second.

5-8. Remote Voltage Control (Optional)

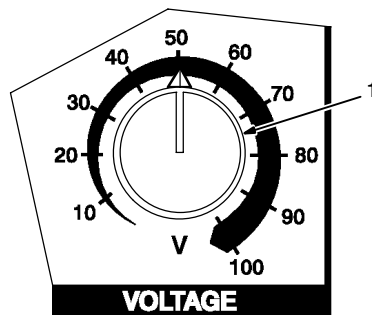

1 Voltage Control

Use control to adjust arc voltage at the wire feeder.

The scale around the control is marked in percent.

5-9. Power Switch

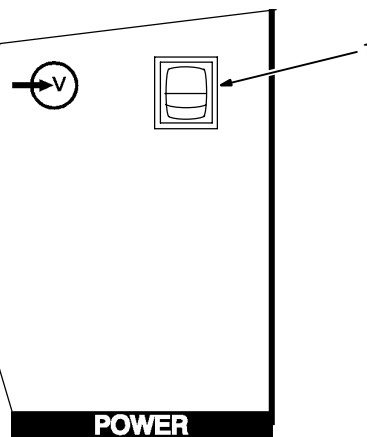

1 Power Switch

Use switch to turn unit On and Off.

5-10. Flowmeter (Optional)



CAUTION

Wire feeding system is designed for maximum of 50 psi (345 kPa) gas pressure.

- Be sure that regulator/flowmeter has preset conditions of no more than 50 psi (345 kPa) gas pressure.

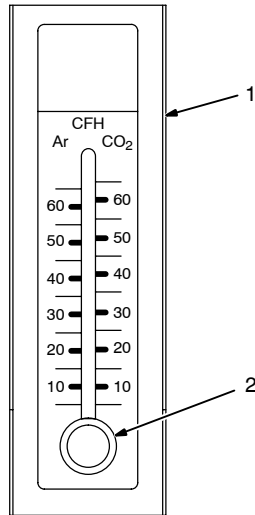

- 1 Flowmeter
- 2 Valve

Use flowmeter to control shielding gas flow at the feeder. The scale on the flowmeter is in cubic feet per hour (CFH). Read gas flow at the widest part of the float in the meter. Rotate valve to change gas flow as necessary.

A regulator is still required on shielding gas supply with this option.

S-0659

5-11. Internal Controls

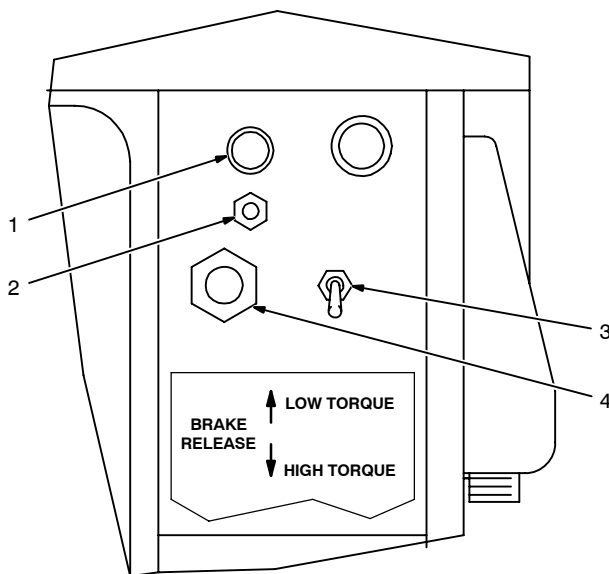

Open left side door.

- 1 Fuse F1

See Section 6-11.

- 2 Circuit Breaker CB1

See Section 6-11.

- 3 Motor Torque Switch

Use switch to select the force used to push wire. The up position is for low force, or torque. The down position is for high force, or torque.

If welding wire appears to be kinked, nicked, or damaged, place switch in low torque position.

- 4 Brake Release Button

Whenever power is On and the welding power source is energized, button may be pressed to release spool brake so wire spool can turn freely.

Close and latch door.

Ref. 151 779 / Ref. S-120 552-A

5-12. Gun Controls

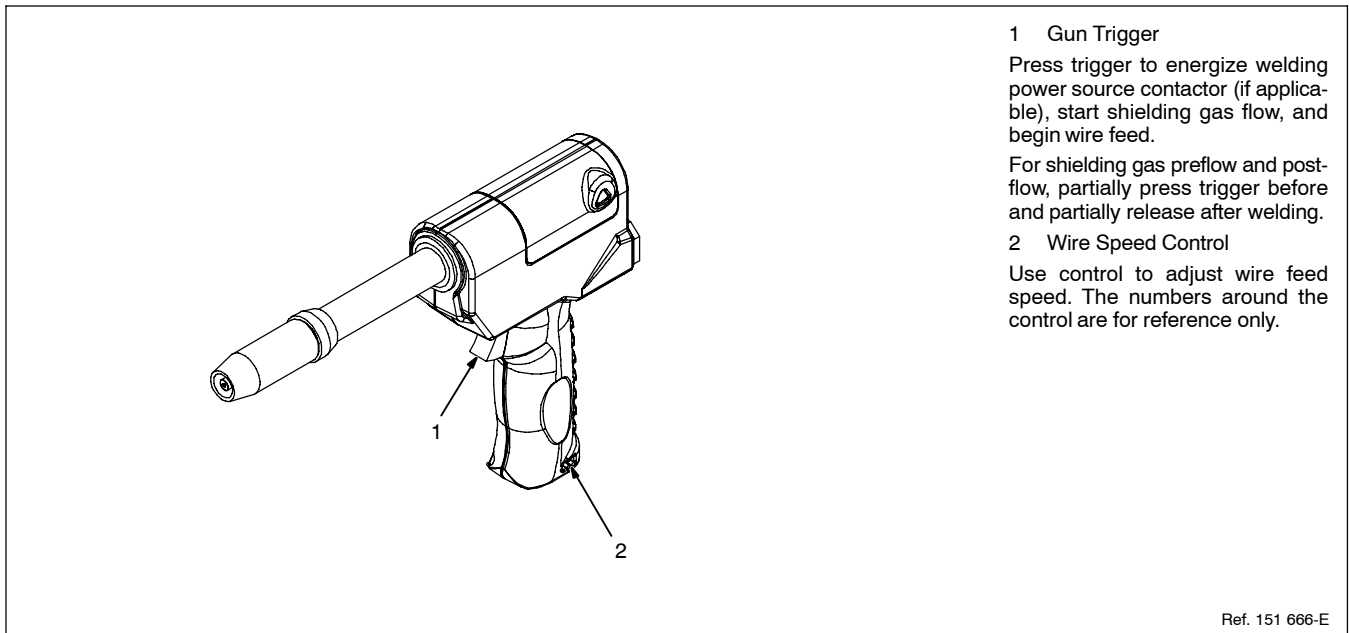

5-13. Shielding Gas

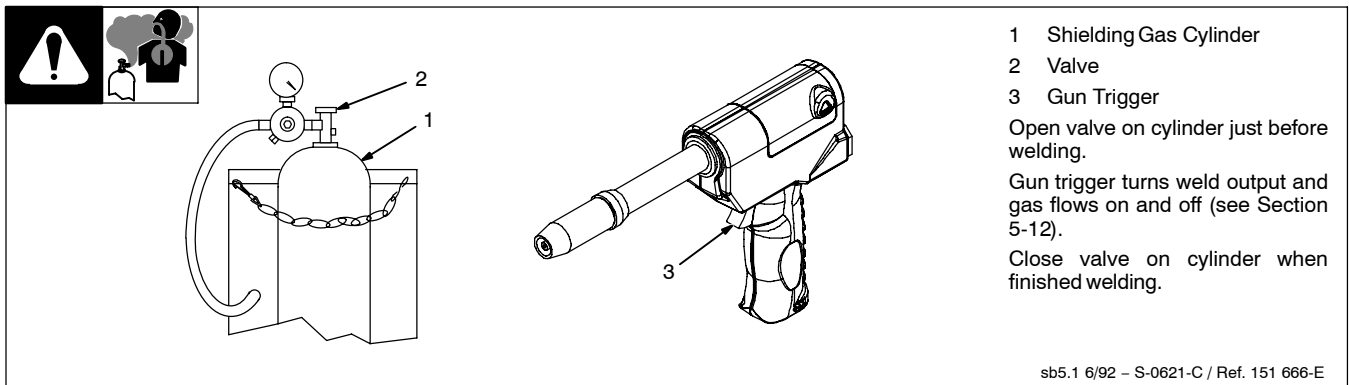

5-14. Coolant Supply For Water-Cooled Models Only

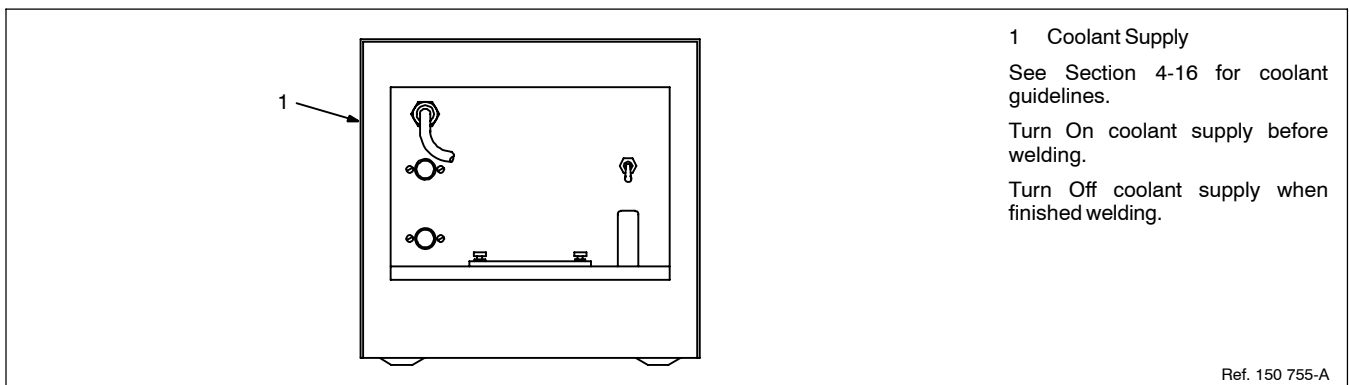

5-15. Sequence Of Gas Metal Arc Welding (GMAW) – Continuous Or Spot

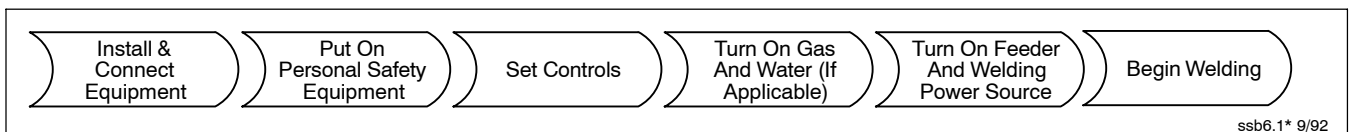

SECTION 6 – MAINTENANCE & TROUBLESHOOTING

6-1. Routine Maintenance

		Turn Off all power before maintaining.	
<p>3 Months</p> <p>See Section 7</p> <p>Replace Unreadable Labels</p>		<p>3 Months</p> <p>Tape Or Replace Cracked Weld Cable</p>	
<p>4-8</p> <p>Clean And Tighten Weld Terminals</p>		<p>Replace Cracked Parts</p> <p>14-Pin Cord</p>	
		<p>Gas Hose</p> <p>Gun Cable</p>	
<p>6 Months</p> <p>Blow Out Or Vacuum Inside</p> <p>During Heavy Service, Clean Monthly</p> <p>Clean Drive Rolls</p>			

6-2. Changing Or Cleaning Gun Drive Roll

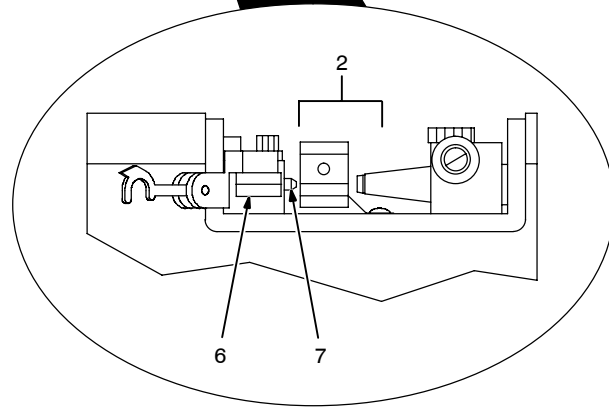
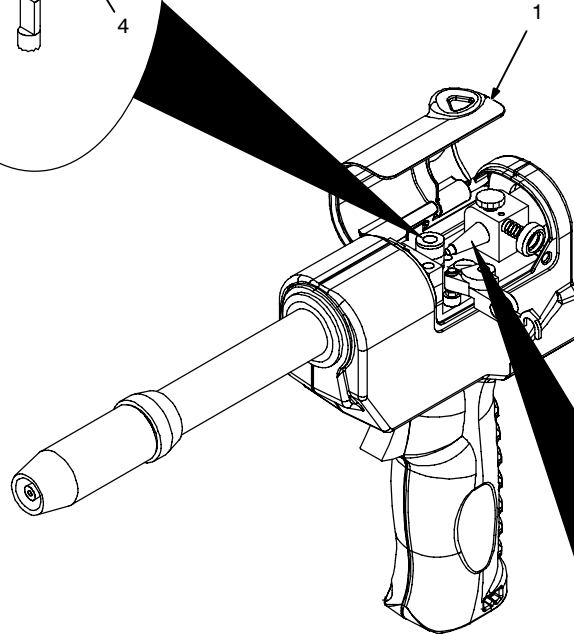
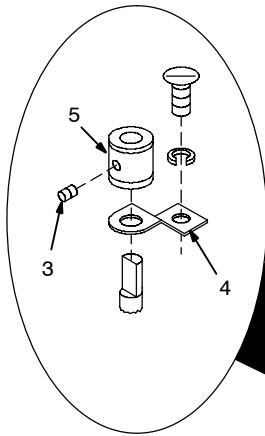

Turn Off wire feeder and welding power source.

- 1 Top Cover
- 2 Pressure Roll Assembly

Cut off wire where it enters pressure roll assembly area.

- 3 Setscrew
- 4 Current Pick-Up Tab

This tab helps prevent burnback caused by welding arcs inside the contact tip. This tab may be removed to provide an insulated drive roll. (If tab is removed, a smaller diameter contact tip is recommended. See options in Parts List.) Lightly grease top of tab before reinstalling.

- 5 Drive Roll

Use wire brush to clean drive roll. Install drive roll with desired groove down, and turn drive roll so one setscrew faces flat side of shaft.

- 6 Bearing

- 7 Liner

Line up drive roll groove with bearing groove and liner opening. Tighten setscrews.

If changing drive roll in feeder, proceed to Section 6-3.

Thread welding wire through gun, and adjust drive roll pressure, if necessary (see Section 4-15). Close and secure pressure roll assembly. Reinstall top cover.

Tools Needed:

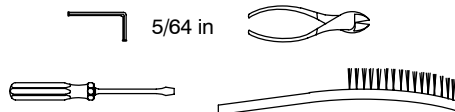

Ref. 151 599-F

6-3. Changing Feeder Drive Roll And Wire Inlet Guide

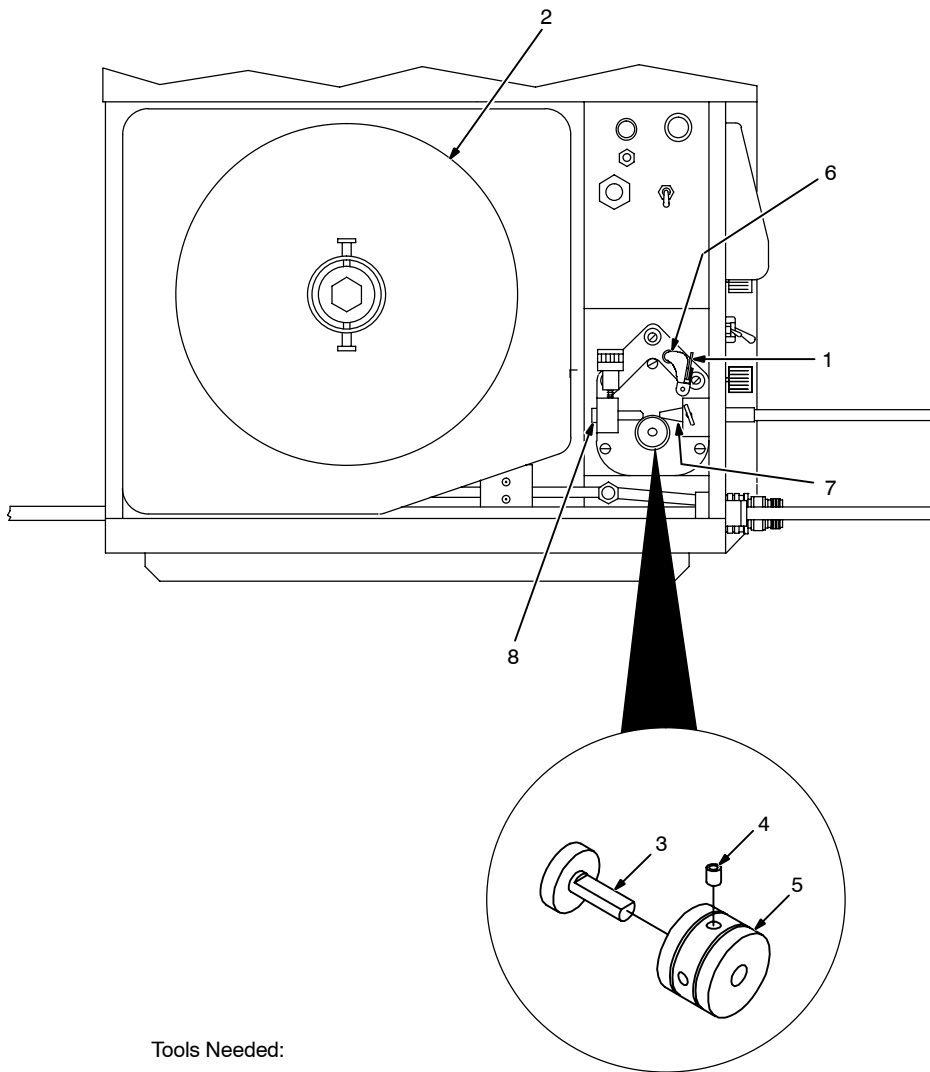

Turn Off wire feeder and welding power source. Lay wire conduit out straight.

Open gun pressure roll assembly, and cut welding wire off at contact tip.

- 1 Pressure Roll Assembly
- 2 Wire Spool

For welding power sources without contactor, retract wire onto spool.

For welding power sources with a contactor, energize power source, turn On feeder, press Brake Release button, and retract wire onto spool.

- 3 Shaft
- 4 Setscrew
- 5 Drive Roll

Use wire brush to clean drive roll. Install drive roll with desired groove in, and turn drive roll so one setscrew faces flat side of shaft.

- 6 Bearing
- 7 Wire Conduit Fitting

Line up drive roll groove with bearing groove and opening in conduit fitting. Tighten setscrews.

- 8 Wire Inlet Guide

Pull guide toward rear of feeder to remove. Install new guide.

Thread welding wire and adjust drive roll pressure, if necessary (see Section 4-14). Close and secure pressure roll assembly. Close and latch door.

Close gun pressure roll assembly, and reinstall gun cover.

Tools Needed:

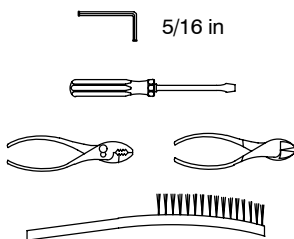

6-4. Replacing Or Cleaning Gun Drive Roll Bearing

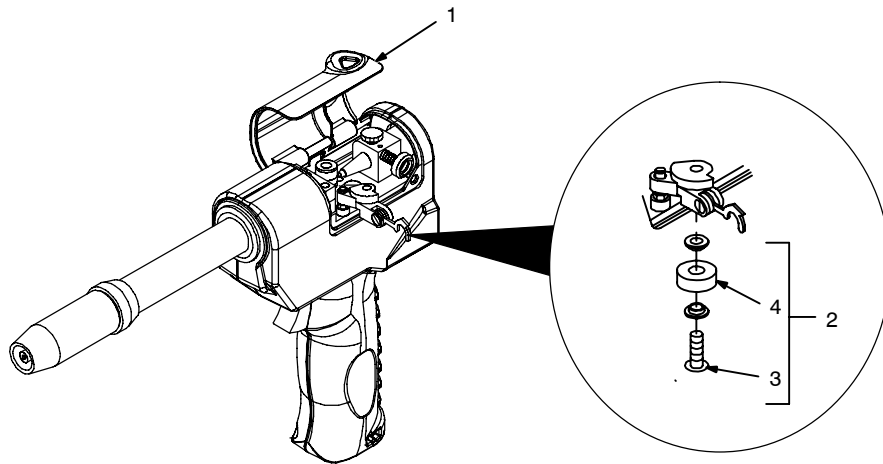

Turn Off wire feeder and welding power source.

- 1 Top Cover
- 2 Pressure Roll Assembly
- 3 Screw
- 4 Pressure Roll

Remove as shown.

Use a wire brush to clean bearing. Reinstall with washers, and tighten screw.

Close pressure roll assembly. Reinstall top cover.

Tools Needed:

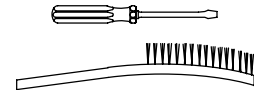

Ref. 151 599-F

6-5. Replacing Or Cleaning Feeder Drive Roll Bearing

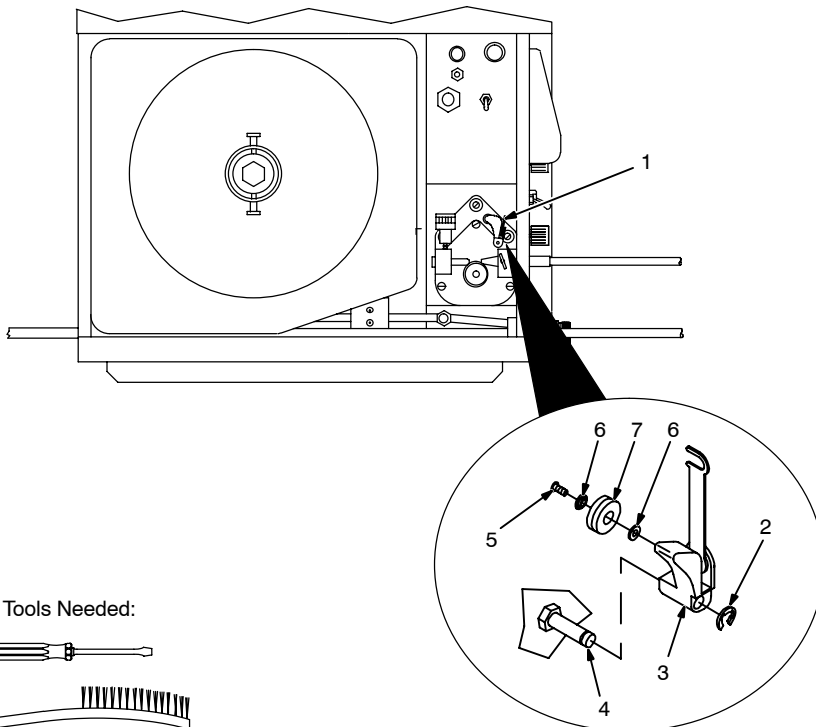
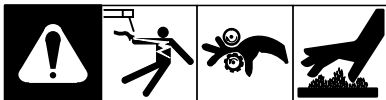

Turn Off wire feeder and welding power source.

- 1 Pressure Roll Assembly
- 2 Retaining Ring
- 3 Mounting Arm
- 4 Hinge Pin
- 5 Screw
- 6 Shoulder Washer
- 7 Drive Roll Bearing

Remove as shown.

Use a wire brush to clean bearing. Reinstall, and tighten screw.

Close pressure roll assembly. Close and latch door.

Tools Needed:

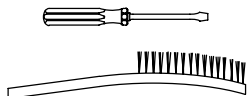

151 778 / Ref. 151 781-B

6-6. Changing Gun Contact Tip

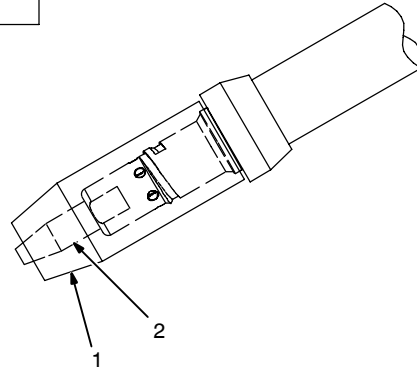

- Remove nozzle
- 1 Nozzle
 - 2 FasTip
- Unscrew FasTip.
Install new FasTip.

Ref. 150 437-A

6-7. Removing Diffuser In Air And Water-Cooled Pistol-Grip Guns

WARNING

WATER IN GUN PARTS can cause ELECTRIC SHOCK and can lower weld quality.

- Turn Off welding power source and water supply before working on gun. Stop engine on welding generators.
- Always point gun downward when removing water-cooled barrel to keep water out of gun parts.
- Wipe gun dry before putting it back together.



- Turn Off welding power source.
- 1 Nozzle
 - 2 FasTip
- To remove, see Section 6-6.
- 3 Diffuser
- Remove diffuser and replace.

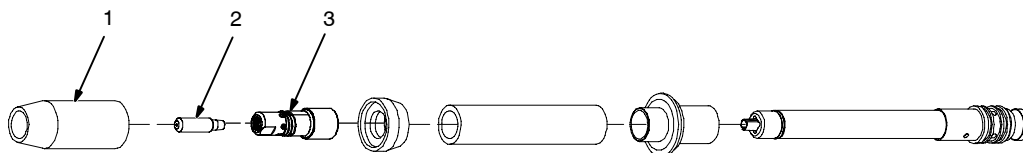

Air Cooled Head Tube Assembly

Tools Needed:

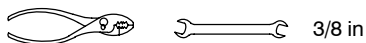

Ref. 803 348-G

6-8. Replacing The Liner

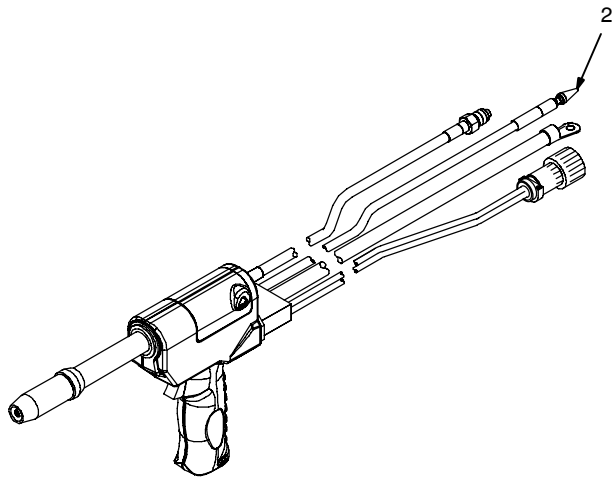
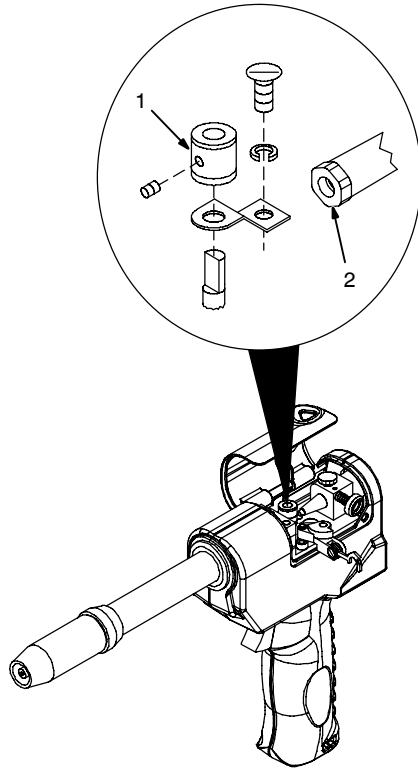
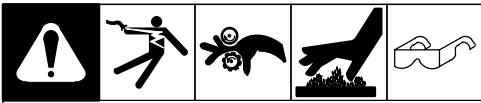

▲ Turn Off welding power source and wire feeder.

- 1 Drive Roll
- 2 Collet Nut

Lay gun cable out straight. Remove drive roll on gun and collet nut on on both ends of liner tube assembly and remove old liner.

- 3 New Liner

Insert split end of new liner into liner tube assembly and continue feeding liner through cable assembly until liner is through liner tube assembly and all of split portion is visible.

If gun is a 15 ft (4.5 m) model, push the split end of liner through until the opposite end is sticking out of the gun connector 1 to 2 inches (2.5 to 5 cm). After trimming, the section with the split on it can be saved to use as another replacement liner.

Cut off split portion of liner. Replace front collet nut with new plastic nut from the liner kit. Reinstall steel nut at gun connector and tighten onto liner.

May be easier to replace the collet nut with the liner conduit removed from the gun housing block.

The liner end will not stick out of the plastic collet nut supplied with the liner kit.

At the gun connection end, cut liner as close as possible to control (push motor) drive rolls.

Refer to Owner's Manual for instructions on rethreading wire.

6-9. Replacing Hub Assembly

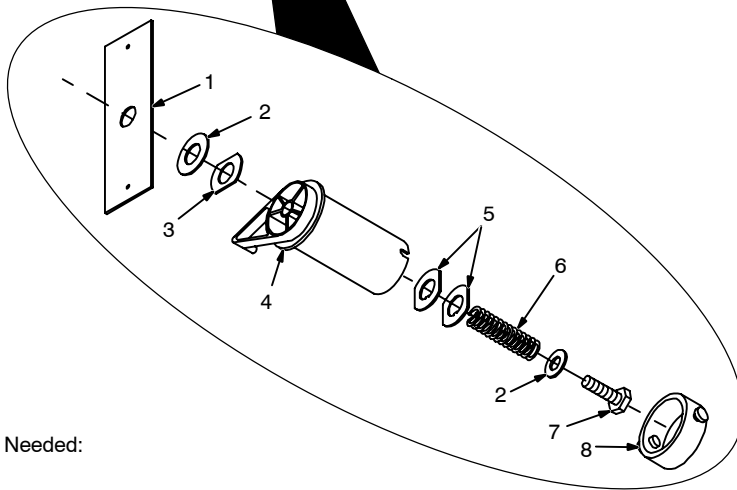
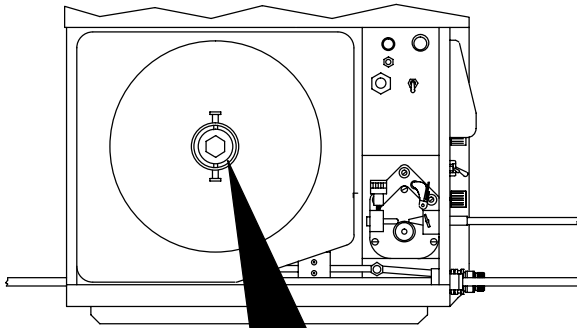

Tools Needed:



Turn Off wire feeder and welding power source. Remove gun top cover and open pressure roll assembly as shown in Section 6-4.

Retract wire onto spool and remove spool. Take hub apart as shown.

- 1 Metal Brake Washer
- 2 Flat Washer
- 3 Brake Washer
- 4 Hub
- 5 Keyed Washer
- 6 Spring
- 7 Cap Screw
- 8 Retaining Ring

Replace broken or worn parts and slide parts onto shaft as shown.

Adjust hub tension (see Section 6-10). Thread welding wire (see Section 4-14). Close and latch door.

Close gun pressure roll assembly and reinstall gun cover.

151 778-B / Ref. 143 223-A

6-10. Adjusting Hub Tension

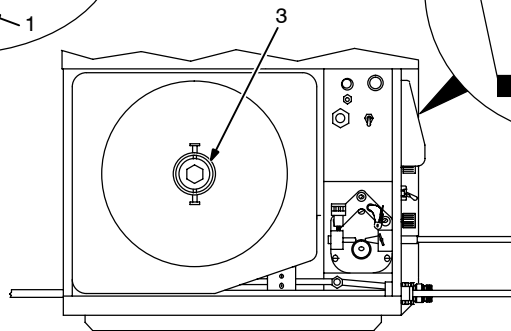
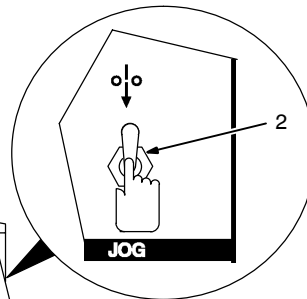
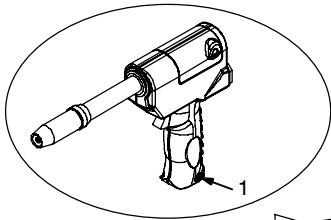

Tools Needed:

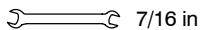

Turn On welding power source and wire feeder to make this adjustment.

1 Wire Speed Control

Adjust control to wire speed for welding.

2 Jog Switch

Push up, and then release Jog switch. Hub tension is okay if wire unwinds freely, but wire does not backlash when Jog switch is released.

3 Cap Screw

Turn cap screw to adjust hub tension. Do not overtighten. Turn Off welding power source and wire feeder. Close and latch door.

151 666-E / Ref. 802 536 / Ref. 176 700-A

6-11. Overload Protection

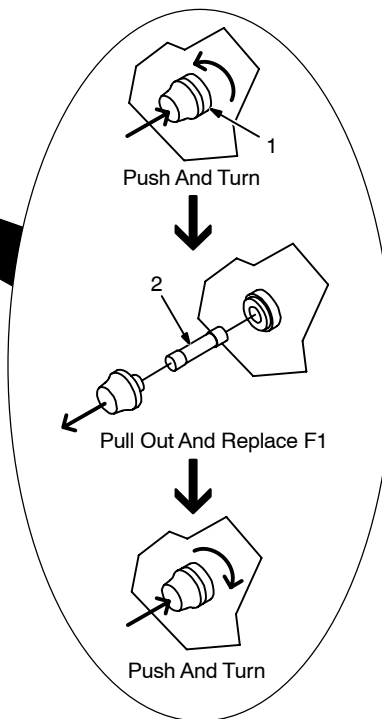
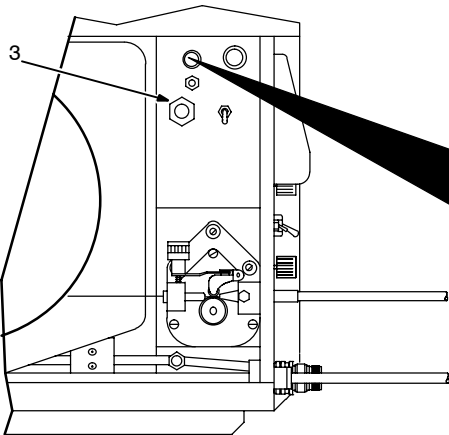
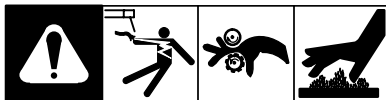

Turn Off wire feeder and welding power source.

If F1 opens, the unit shuts down. To check or change F1, proceed as follows:

1 Fuse Holder Cover

2 Fuse F1 (See Parts List For Rating)

Insert new fuse into cover, and install fuse with cover by pressing and turning cover clockwise.

3 Circuit Breaker CB1

If CB1 opens, the gun drive motor and contactor will not operate, but gas flows when trigger is pulled. The gun drive motor operates in the Jog mode with CB1 open.

Check for blocked gun liner.

Check for jammed wire, binding drive gear or misaligned drive rolls in feeder. Correct problem.

Allow cooling period and manually reset breaker. Close and latch door.

Ref. 151 779-A / Ref. 800 185-A

6-12. Water Flow Switch (Optional For Water-Cooled Models)

The water flow switch protects the gun from overheating. If coolant flow rate drops below 1 qt/min, the water flow switch opens and stops the welding wire from feeding. See Section 6-13 for remedies to this trouble.

6-13. Troubleshooting

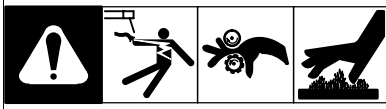

A. Wire Feeder Trouble

Trouble	Remedy
Pressing gun trigger does not energize feeder. Welding wire is not energized. Shielding gas flows.	Secure plug from gun control cable into Gun Control receptacle on feeder (see Section 4-6).
	Secure 115 VAC input plug connection (see Section 4-11).
	Check fuse F1 (see Section 6-11).
	Check water connection to feeder or gun (see Sections 4-6 and 4-8).
	Check for kinks in water hose.
	Be sure coolant supply is turned On (see Section 5-14).
	Have nearest Factory Authorized Service Station/Service Distributor check optional water flow switch, if applicable (see Section 6-12).
Wire feeds, shielding gas flows, but welding wire is not energized.	Secure 115 VAC/contacter control plug connection (see Section 4-11).
	See Troubleshooting section in welding power source manual.
	Check plug PLG50, PLG51 and PLG52 connections (see Section 4-12).
Wire feeds erratically.	Check position of Motor Torque switch (see Section 5-11).
	Adjust drive roll pressure if necessary (see Section 4-14).
	Replace or clean drive rolls as necessary (see Sections 6-2 and 6-3).
	Align drive roll with opening in gun conduit fitting and groove in bearing (see Section 6-3).
Arc varies and welding wire is kinked when feeding out gun.	Place Motor Torque switch in low torque position if welding with .030 (0.8 mm) aluminum welding wire (see Section 5-11).
Pressing gun trigger will not feed wire, wire is not energized, shielding gas flows, and Jog switch activates motor.	Reset circuit breaker CB1 (see Section 6-11).
Feeder feeds wire but remains in run-in mode after arc initiation.	Route weld cable through current sensing relay (see Section 4-8).
	If constant current (CC) welding, be sure PLG5 is in EXT. position on PC1, and voltage sensing lead is connected (see Section 4-10).
	If constant voltage (CV) welding, be sure PLG5 is in INT. position on PC1, and that voltage sensing lead is not connected (see Section 4-10).
Feeder feeds wire, but switches from weld mode to run-in mode while CV welding with voltage sensing lead installed.	Be sure PLG5 is in INT. position on PC1. Disconnect voltage sensing clamp from workpiece (see Section 4-10).
Shielding gas leak through gas valve in gun.	Reduce shielding gas pressure at regulator flowmeter. Do not exceed 50 psi (345 kPa).

B. Gun Trouble

Trouble	Remedy
No weld output; gun/feeder does not work.	Secure 115 VAC input plug in 115 volts ac receptacle (see Section 4-11).
	Place Power switch on welding power source in the On position.
Erratic weld output.	Tighten and clean all connections.
Pressing gun/feeder trigger does not energize weld control; welding wire is not energized; shielding gas does not flow.	Secure plug from gun control cable into 10-socket receptacle on wire feeder (see Section 4-6).
Wire does not feed; burnback in contact tip.	Reinstall current pick-up tab if applicable (see Section 6-2).
Wire feeds, shielding gas flows, but welding wire is not energized.	Clean or replace drive rolls. See Troubleshooting section in welding power source Owner's Manual (see Sections 6-2 and 6-3).
Wire feeds erratically.	Check and correct drive roll pressure (see Section 4-14).
	Clean drive roll or replace drive roll (see Sections 6-2 and 6-3).
Gun overheating (water-cooled models).	Be sure coolant flowrate is at least 1 qt/min (0.95 L/min).
	Corrosion buildup in gun decreasing coolant flowrate. Backflush coolant system, clean coolant system filter, and clean fittings (see Section 4-16).

SECTION 7 - ELECTRICAL DIAGRAMS

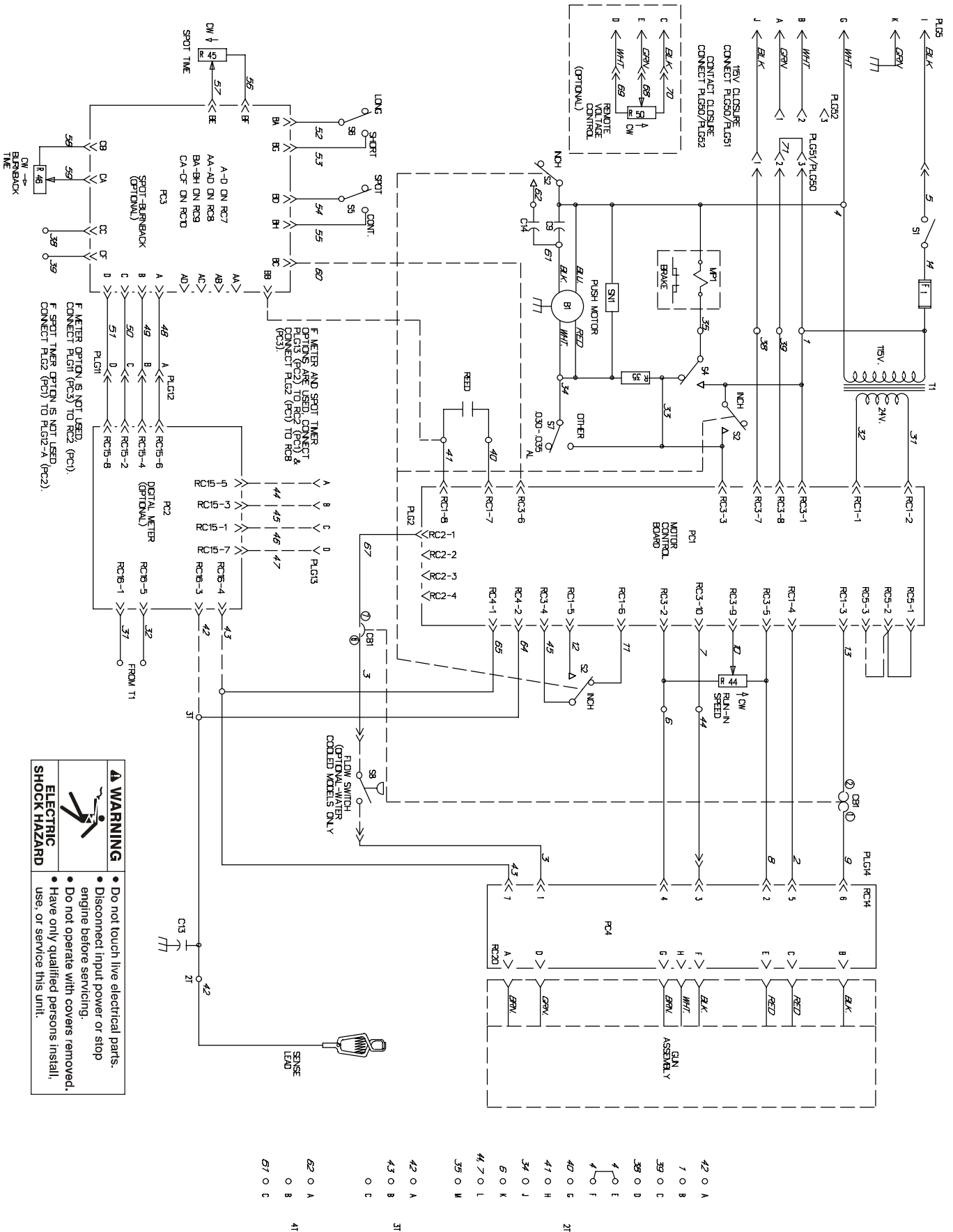

WARNING

ELECTRIC SHOCK HAZARD

- Do not touch live electrical parts.
- Disconnect input power or stop engine before servicing.
- Do not operate with covers removed.
- Have only qualified persons install, use, or service this unit.

Figure 7-1. Circuit Diagram For Wire Feeder

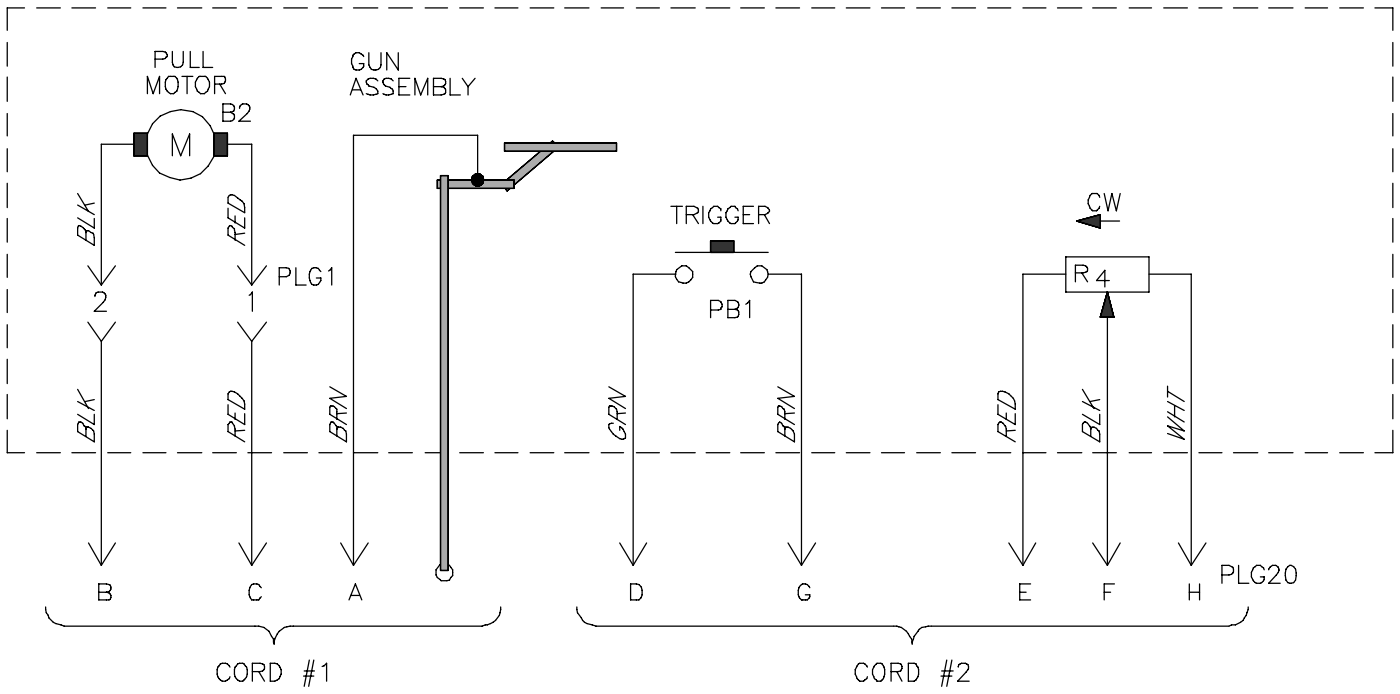

195 712-B

⚠ WARNING  ELECTRIC SHOCK HAZARD	<ul style="list-style-type: none"> • Do not touch live electrical parts. • Disconnect input power or stop engine before servicing. • Do not operate with covers removed. • Have only qualified persons install, use, or service this unit.
---	--

Figure 7-2. Circuit Diagram For Gun

Notes

SECTION 8 - PARTS LIST

☞ Hardware is common and not available unless listed.

☞ This main assembly drawing shows the XR-W (water-cooled model). Some parts for the XR-A (air-cooled model) vary in appearance. When differences occur, they are called out in the part description.

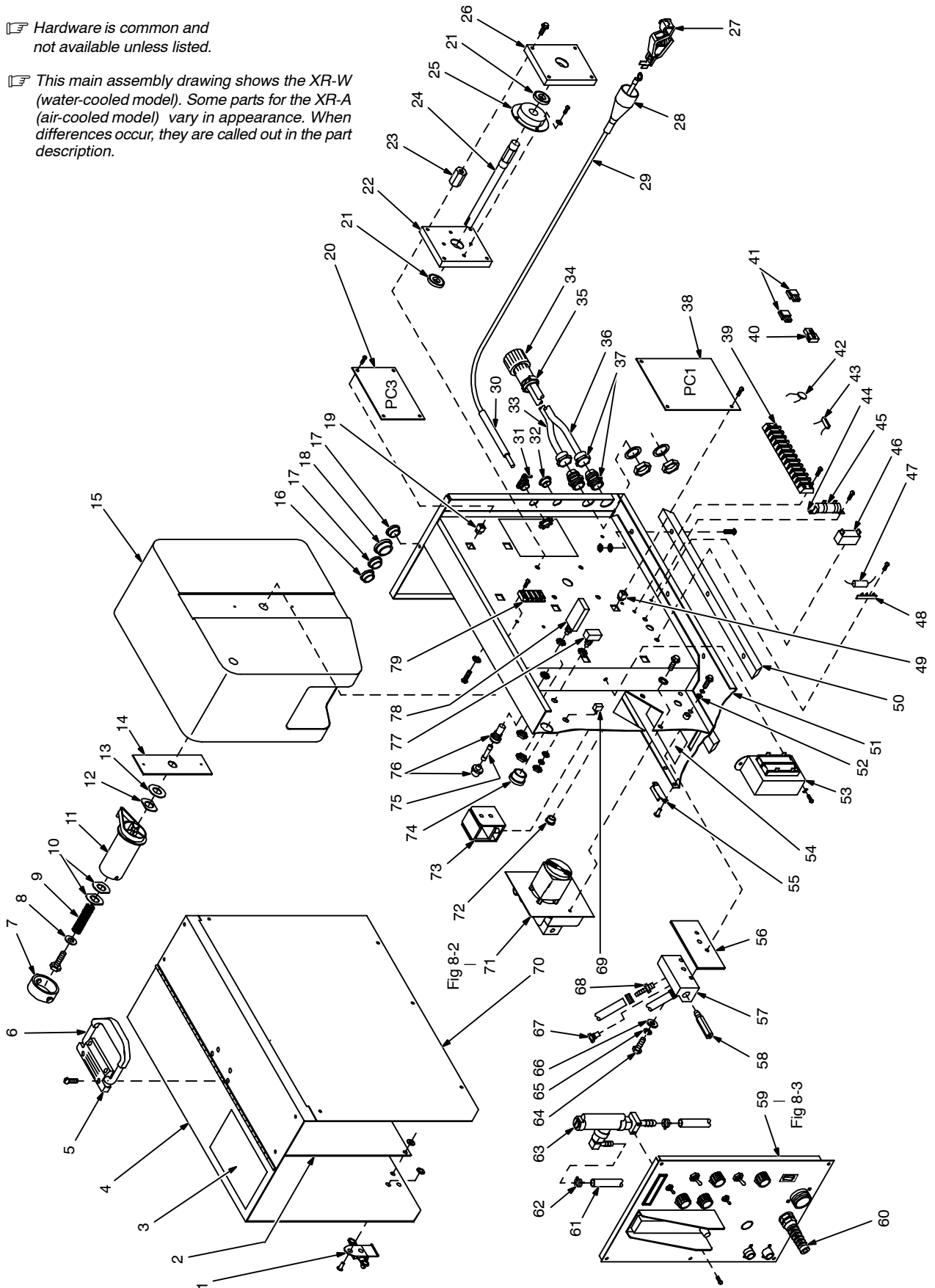

Figure 8-1. Main Assembly

Item No.	Dia. Mkgs.	Part No.	Description	Quantity
Figure 8-1. Main Assembly				
1		089 572	Catch, Link-lock	2
2		112 167	Insulator, Door	1
3		134 327	Label, Warning General Precautionary	1
4		+113 569	Wrapper	1
5		126 415	Clamp, Saddle	1
6		126 416	Handle, Molded	1
7		058 427	Ring, Retaining Spool	1
8		602 233	Washer, Flat Stl .250 Id X .875 Od X .062Thk	1
9		057 543	Spring, Cprsn .845 Od X .091 Wire X 1.500	1
10		113 168	Washer, Locking	2
11		058 428	Hub, Spool	1
12		089 561	Washer, Anti-turn Stl	1
13		058 424	Washer, Fbr Brake	1
14		151 697	Strip, Brake Surface Anti-turn	1
15		112 198	Shroud, Spool Wire 12 In	1
16		030 170	Bushing, Snap-in Nyl .750 Id X 1.000Mtg Hole	1
17		057 357	Bushing, Snap-in Nyl .937 Id X 1.125Mtg Hole (Water-cooled Model)	2
17		057 357	Bushing, Snap-in Nyl .937 Id X 1.125Mtg Hole (Air-cooled Model)	1
17		070 371	Blank, Snap-in Nyl 1.093/1.125Mtg Hole (Air-cooled Model)	1
18		057 358	Bushing, Snap-in Nyl 1.000 Id X 1.375Mtg Hole	1
19		◆134 201	Stand-off, PC Card	4
20	PC3	◆114 538	Circuit Card, Spot-burnback	1
	PLG7,8,11	◆115 094	Housing Plug & Sockets	3
	PLG9	◆115 092	Housing Plug & Sockets	1
	PLG10	◆115 093	Housing Plug & Sockets	1
21		073 302	Bearing, Ball Rdl Sgl Row .669 X 1.378 X .39	2
22		113 161	Block, Bearing Front	1
23		113 165	Stand-off, .250-20 X 1.000 Lg	4
24		120 396	Shaft, Spool	1
25	MP1	113 899	Brake, W/Terminals	1
26		113 900	Block, Bearing Rear	1
27		601 228	Clamp, Univ 25A	1
28		601 226	Insulator, Vinyl Clamp Univ 25A	1
29		600 848	Wire, Lead Mot 12Ga Strd (Order By Ft)	35ft
30		176 089	Tubing, Plstc PVC Black	1ft
31		115 104	Connector, Clamp Cable .500	1
32		000 527	Blank, Snap-in Nyl .875Mtg Hole	1
33		007 826	Cable, Port No. 18 3/C (Order By Ft)	11ft
34	PLG5	141 162	Housing Plug & Pins	1
35		079 739	Clamp, Cable Strain Relief	1
36		007 826	Cable, Port No 18 3/C (Order By Ft)	11ft
36		◆007 826	Cable, Port No. 18 3/C (Order By Ft)	11ft
37		139 042	Bushing, Strain Relief .270/.480 Id X .804Mtg Hole	2
37		◆139 042	Bushing, Strain Relief .270/.480 Id X .804Mtg Hole	1
38	PC1	142 053	Circuit Card, Motor Speed Control	1
	PLG1	115 092	Housing Plug & Sockets	1
	PLG2	115 094	Housing Plug & Sockets	1
	PLG3	115 091	Housing Plug & Sockets	1
	PLG4	131 054	Housing Receptacle & Sockets	1
39	2T	038 783	Block, Term 20A 12P	1
40	PLG50	131 203	Housing Plug & Pins	1
41	PLG51,52	131 204	Housing Plug & Sockets	2
42	C13	117 500	Capacitor	1
43	SN1	110 079	Snubber, Polye Mf .5Uf 200VDC	1
44		605 741	Clip, Mtg Resistor .312 Id Core	2
45	R35	030 087	Resistor, Ww Fxd 25W 200 Ohm	1
46	C9	114 215	Capacitor, Polye Film 2.3Uf 250VAC	1
47	C14	044 602	Capacitor, Polye Film .47Uf 400VDC	1
48	4T	038 785	Strip, Term 3P	1
49		134 201	Stand-off Support, PC Card	4

Item No.	Dia. Mkgs.	Part No.	Description	Quantity
Figure 8-1. Main Assembly (Continued)				
.. 50		111 152	.. Skid, Base	2
.. 51		+176 714	.. Cabinet, Control	1
		153 901	.. Label, Caution The Recommended Coolant To Be	1
.. 52		605 970	.. Washer, Shldr Nyl .310 Od X .252 Id X .064 (Water-cooled Model)	4
.. 52		605 970	.. Washer, Shldr Nyl .310 Od X .252 Id X .064 (Air-cooled Model)	3
.. 53	T1	090 465	.. Transformer, Signal 115V 24Vct 4A	1
.. 54		090 439	.. Label, Warning Electric Shock Can Kill	1
.. 55		089 573	.. Plate, Keeper Link-lock	2
.. 56		131 318	.. Insulator, Block Connection (Water-cooled Model)	1
.. 56		113 166	.. Insulator, Term (Air-cooled Model)	1
.. 57		131 311	.. Block, Connection	1
.. 58		150 067	.. Fitting, Water Block Extension	1
.. 59		Fig 8-3	.. Panel, Front W/Components	1
.. 60		121 276	.. Bushing, Strain Relief .709 Id X 1.115Mtg Hole	1
.. 61		◆◆◆134 834	.. Hose, Sae .187 Id X .410 Od (Order By Ft)	2ft
.. 62		◆◆◆089 120	.. Clamp, Hose .375-.450Clp Dia Slfittng	4
.. 63	S8	◆◆◆164 963	.. Switch, Flow W/Fittings	1
.. 64		601966	.. Screw, Cap Stl Hexhd .375-16 X 1.250 (Water-cooled Model)	1
.. 64		117 498	.. Terminal, Pwr Weld (Air-cooled Model)	1
		117 496	.. Washer, Fbr .312 Id X .750 Od X .062Thk (Air-cooled Model)	2
		075 150	.. Washer, Shldr Nyl 1.000 Od X .375 Id (Air-cooled Model)	1
		010 910	.. Washer, Flat Stl Sae .375 (Air-cooled Model)	2
		601 872	.. Nut, Stl Hex Full .375-16	2
.. 65		602 213	.. Washer, Lock Stl Split .375	1
.. 66		602 243	.. Washer, Flat Stl Std .375	1
.. 67		151 663	.. Fitting, Plug Water Block	1
.. 67		151 664	.. Fitting, Diverter Water Block	1
.. 68		◆◆◆151 662	.. Fitting, Pipe Brs Plug Hex .125Npt	2
.. 68		◆◆◆073 432	.. Fitting, Brs Barbed M 3/16Tbg X 1/8Npt	2
.. 69	S7	011 770	.. Switch, Tgl Spdt 5A 125V	1
.. 70		113 565	.. Door, Rh	1
.. 71		Fig 8-2	.. Motor & Wire Drive	1
.. 72		010 546	.. Bushing, Snap-in Nyl .375 Id X .500Mtg Hole	1
.. 73	REED	140 786	.. Switch, Reed	1
.. 74		010 493	.. Bushing, Snap-in Nyl .625 Id X .875Mtg Hole	1
.. 75	F1	*012 663	.. Fuse, Mintr Gl Slo-blo 3A	1
.. 76		046 432	.. Holder, Fuse Mintr .250 X 1.250 Panel Mtg	1
.. 77	S4	011 232	.. Switch, Pb Spdt	1
.. 78	CB1	174 092	.. Circuit Breaker, Man Reset 1P .7A 250VAC	1
.. 79	3t	038 861	.. Block, Term 20A 3P	1
		601 219	.. Link, Jumper Term Blk 20A	1
.. 80		211 989	.. Fitting, W/Screen	1

+When ordering a component originally displaying a precautionary label, the label should also be ordered.

◆Part of Spot Weld Control Option

◆◆Part of Voltage Control Option

◆◆◆Part of Water Flow Shutdown Switch Option

*Recommended Spare Parts.

To maintain the factory original performance of your equipment, use only Manufacturer's Suggested Replacement Parts. Model and serial number required when ordering parts from your local distributor.

Item No.	Dia. Mkgs.	Part No.	Description	Quantity
----------	------------	----------	-------------	----------

Figure 8-2. Motor & Wire Drive (Fig 8-1 Item 71)

1		115 191	Drive Assembly, Wire (Consisting Of)	1
2		058 968	Ring, Retainer E	1
3		605 798	Washer, Shldr Nyl .375 Od X .168 Id X .080Thk	4
4		120 395	Spring, Tension Pressure Roll	1
5		112 713	Arm, Pressure Roll	1
6		058 409	Bearing	1
7		112 887	Pin, Hinge	1
8		057 544	Spring, Cprsn .240 Od X .026 Wire X 1.000	1
9		120 397	Nut, Thumb Tension Adjustment	1
10		147 626	Cover, Gear Wire Drive	1
11		058 549	Guide, Wire Inlet 1/16	1
12		602 306	Pin, Spring Cs .125 X .500	2
13		008 667	Bearing, Ball Rdl Dbl Row .250 X .687 X .31	2
14		113 170	Gear & Shaft, Motor	1
15		147 624	Case, Gear Wire Drive	1
16		147 625	Block, Anchor Conduit	1
17		054 263	Screw, Thumb Stl .250-20 X .500	1
18		120 398	Roll, Drive V Groove .030-1/16 Wire (Consisting Of)	1
19		602 169	Screw, Set Stl Sch 8-32 X .187 Cup Point	2
20		605 971	Washer, Shldr Nyl .236 Od X .195 Id X .042Thk	3
21		113 162	Insulator, Motor	1
22	B1	113 898	Motor, Torque 115VAC	1
23		113 169	Gear, Driver	1
24		604 612	Screw, Set Stl Sch 8-32 X .125 Cup Point	2

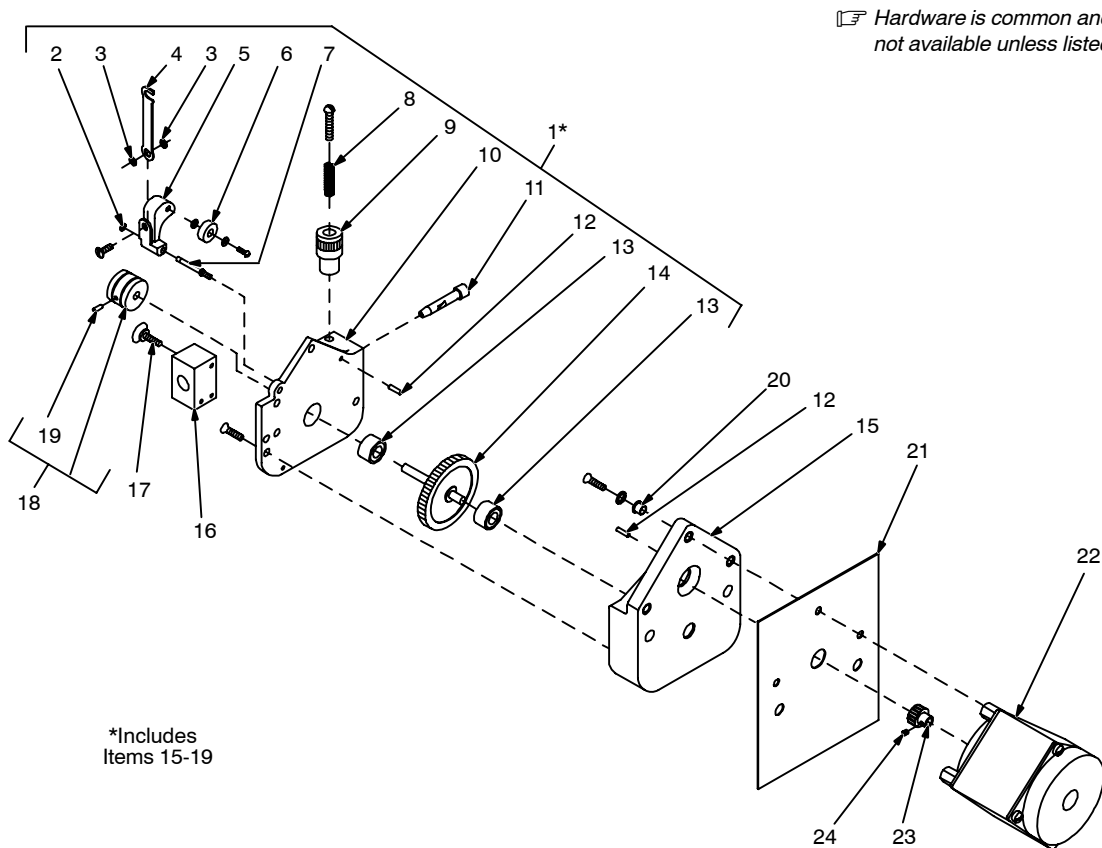
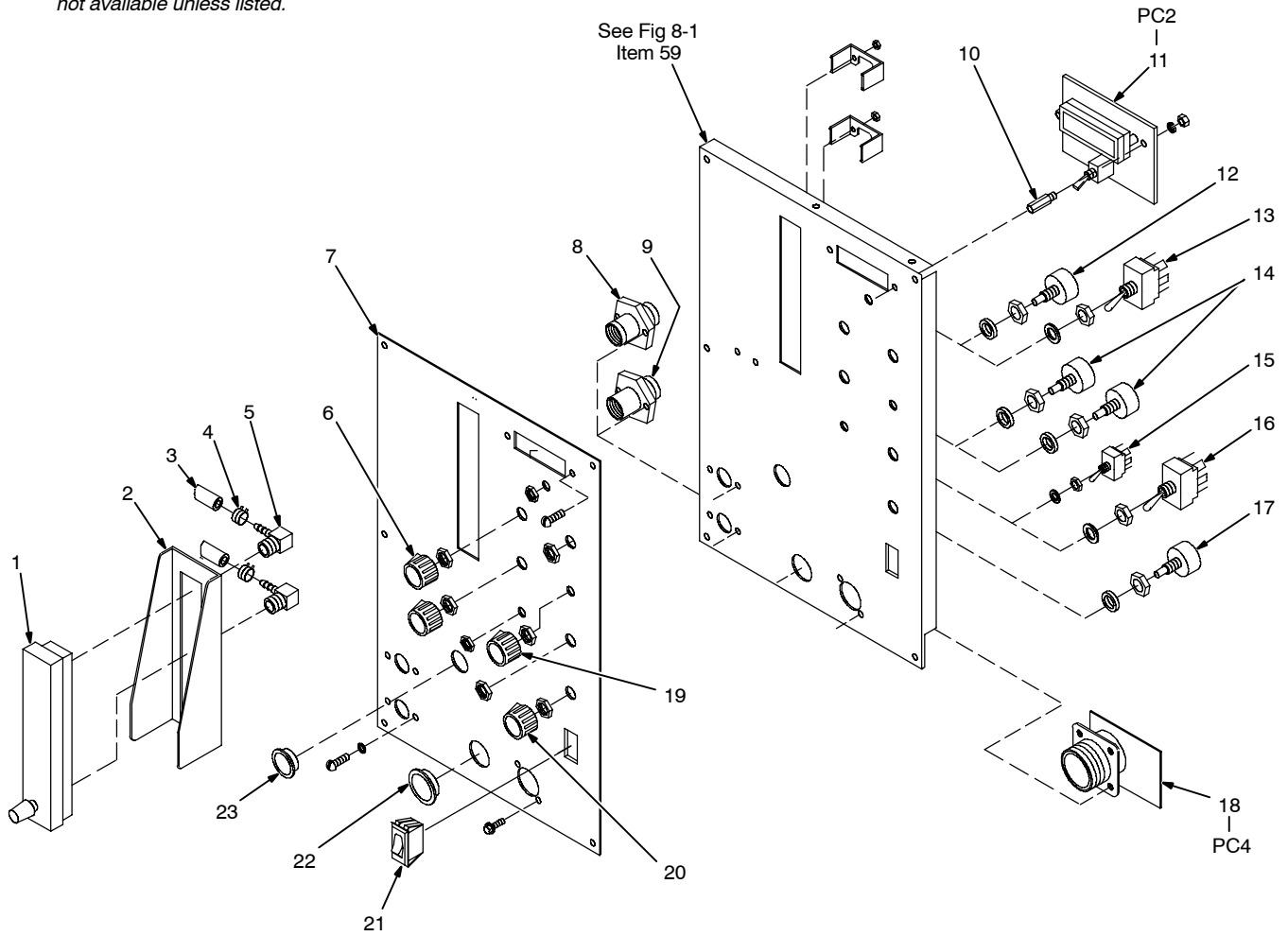

Figure 8-2. Motor & Wire Drive

To maintain the factory original performance of your equipment, use only **Manufacturer's Suggested Replacement Parts**. Model and serial number required when ordering parts from your local distributor.

☞ Hardware is common and not available unless listed.



145 127-B

Figure 8-3. Panel, Front w/Components (Water-Cooled Model Illustrated)

Item No.	Dia. Mkgs.	Part No.	Description	Quantity
----------	------------	----------	-------------	----------

Figure 8-3. Panel, Front w/Components (Fig 8-1 Item 59)

1		◆111 569	Meter, Flow 6-60	1
2		◆111 633	Guard, Flow Meter	1
3		◆134 834	Hose, Sae .187 Id X .410 Od (Order By Ft)	4ft
		◆056 851	Fitting, Hose Brs Barbed Nipple 3/16Tbg	2
		◆010 606	Fitting, Hose Brs Nut .625-18	2
		◆056 108	Fitting, Hose Brs Ferrule .425 Id X .718 Lg	2
		◆045 852	Clip, Component .687Dia Mtg Adh Back	1
4		◆089 120	Clamp, Hose .375-.450Clp Dia	2
5		◆112 090	Fitting, Pipe Brs Elb 1/8Npt X 3/16 Hose	2
6		097 922	Knob, Pointer	1
7			Nameplate, (Order By Model And Serial Number)	1
8		139 678	Fitting, Water (Water-cooled Model)	1
8		000 527	Blank, Snap-in Nyl .875Mtg Hole (Air-cooled Model)	1
9		000 434	Fitting, Gas	1
10		◆◆115 443	Stand-off, No. 6-32 X .750 Lg	2
11	PC2	◆◆139 897	Circuit Card, Meter	1
	PLG12	◆◆115 090	Housing Plug & Pins	1
	PLG13	◆◆115 094	Housing Receptacle & Sockets	1
	PLG15	◆◆115 092	Housing Plug & Sockets	1
	PLG16	◆◆131 055	Housing Receptacle & Sockets	1
		136 339	Cover, Opening Meter	1
		120 304	Blank, Snap-in Nyl .250Mtg Hole	1
12	R44	073 562	Potentiometer, C Sltd Sft 1/T 2W 10K Ohm	1
13	S2	120 400	Switch, Tgl 3Pdt Mc 15A 125VAC	1
14	R45,46	◆◆◆028 770	Potentiometer, C Sltd Sft 1/T 2W 1 Meg Ohm	2
15	S6	◆◆◆011 770	Switch, Tgl Spdt 5A 125V	1
16	S5	◆◆◆011 609	Switch, Tgl Spdt 15A 125VAC	1
17	R50	◆◆◆◆035 897	Potentiometer, C Sltd Sft 1/T 2W 1000 Ohm	1
18	PC4, RC20	139 508	Circuit Card, Filter	1
	PLG14	115 092	Housing Plug & Sockets	1
19		◆◆◆097 922	Knob, Pointer	2
20		◆◆◆◆097 922	Knob, Pointer	1
21	S1	111 997	Switch, Rocker Spst 10A 250VAC	1
22		057 357	Bushing, Snap-in Nyl .937 Id X 1.125Mtg Hole (Water-cooled Model)	1
22		070 371	Blank, Snap-in Nyl 1.093/1.125Mtg Hole (Air-cooled Model)	1
23		030 170	Bushing, Snap-in Nyl .750 Id X 1.000Mtg Hole	1

◆Part of Gas Flow Meter Option.

◆◆Part of Meter Kit Option.

◆◆◆Part of Spot Weld Control Option.

◆◆◆◆Part of Voltage Control Option.

To maintain the factory original performance of your equipment, use only Manufacturer's Suggested Replacement Parts. Model and serial number required when ordering parts from your local distributor.

Hardware is common and not available unless listed.

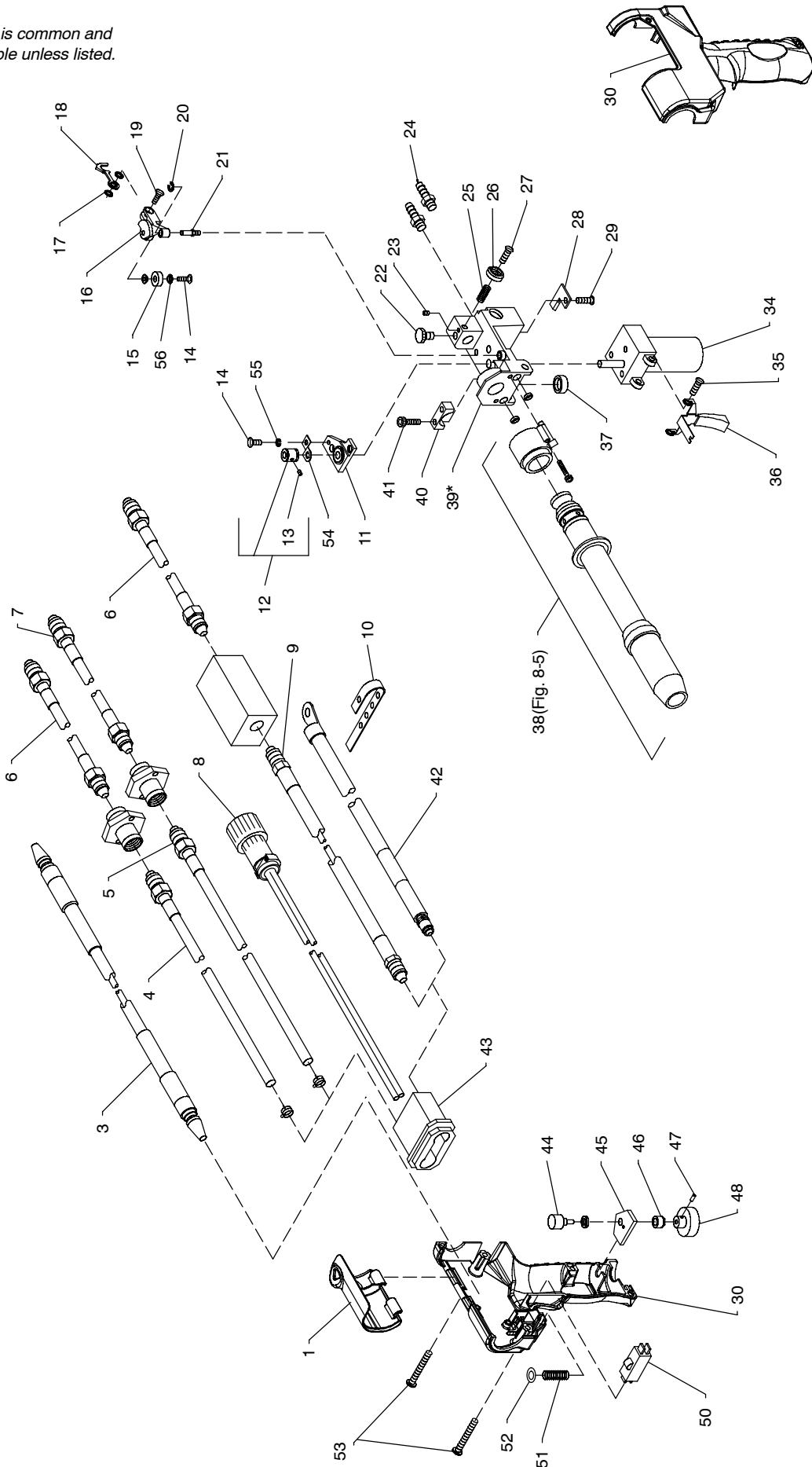

Figure 8-4. Exploded View Of Gun

*Includes Items 24 & 37

Item No.	Dia. Mkgs.	Part No.	Description	Quantity
Figure 8-4. Exploded View Of Gun				
1		214 745	Cover	1
2		Deleted		
3		194 405	Conduit W/Fitting, 15ft (15a & W Models)	1
		204 422	Conduit W/Fitting, Molded 15 Ft	1
		220 879	Tubing, Nyl .120 Id X .175-.180 Od Xroll	16ft
		216 001	Nut, Liner Collet Retaining	1
		185 106	Nut, Liner Collet	1
3		194 410	Conduit W/Fitting, 30ft (30a & W Models)	1
		204 425	Conduit W/Fitting, Molded 30 Ft	1
		220 879	Tubing, Nyl .120 Id X .175-.180 Od Xroll	32ft
		216 001	Nut, Liner Collet Retaining	1
		185 106	Nut, Liner Collet	1
4		137 474	Hose, Water In (15W Model) (Consisting Of)	1
4		137 475	Hose, Water In (30W Model) (Consisting Of)	1
5		137 473	Hose, Gas In (15A & W Models) (Consisting Of)	1
5		137 472	Hose, Gas In (30A & W Models) (Consisting Of)	1
		056 851	Fitting, Hose Brs Barbed Nipple 3/16Tbg	1
		010 607	Fitting, Hose Brs Nut .625-18 Lh (Water Hose)	1
		010 606	Fitting, Hose Brs Nut .625-18Rh (Gas Hose)	1
		056 108	Fitting, Hose Brs Ferrule .425 Id X .718 Lg	1
		134 834	Hose, Sae .187 Id X .410 Od (15A & W Models) (Order By Ft)	16ft
		134 834	Hose, Sae .187 Id X .410 Od (30A & W Models) (Order By Ft)	31ft
		089 120	Clamp, Hose .375-.450Clp Dia Slftng	1
6		000 571	Hose, Water (Xr-15 & 30W Models) (Consisting Of)	2
		056 851	Fitting, Hose Brs Barbed Nipple 3/16Tbg	2
		010 607	Fitting, Hose Brs Nut .625-18 Lh	2
		056 108	Fitting, Hose Brs Ferrule .425 Id X .718 Lg	2
		134 834	Hose, Sae .187 Id X .410 Od (Order By Ft)	10ft
7		048 837	Hose, Gas (Consisting Of)	1
		010 603	Fitting, Hose Brs Barbed Nipple 1/4Tbg	2
		010 606	Fitting, Hose Brs Nut .625-18Rh	2
		056 112	Fitting, Hose Brs Ferrule .475 Id X .718 Lg	2
		603 106	Hose, Nprn Brd No. 1 X .250 Id (Order By Ft)	10ft
8		198 891	Cable, Control 15 Ft (15A & W Models)	1
	PLG20	217 292	Housing Plug+Pins, (Service Kit)	1
8		198 810	Cable, Control 30 Ft (30A & W models)	1
	PLG20	217 292	Housing Plug+Pins, (Service Kit)	1
9		137 476	Cable, Power/Water Out 15Ft (15W Model)	1
9		137 477	Cable, Power/Water Out 30Ft (30W Model)	1
10		073 476	Clamp, Strap Rbr 5 Holes .375 Wide X 4.625 Lg (15A & W Models)	6
10		073 476	Clamp, Strap Rbr 5 Holes .375 Wide X 4.625 Lg (30A & W Models)	13
11		162 041	Bearing Block Assembly	1
		604 638	Screw, Cap Stl Sch 6-32 X .375	3
		143 480	Screw, 6-32 X .625 Soc Hd-Hex Stl	1
12		136 135	Roll, Drive Vk Groove .023-1/16 Wire (Consisting Of)	1
13		604 612	Screw, Set Stl Sch 8-32 X .125 Cup Point	2
14		114 045	Screw, 6-32 X .500 Hexwhd Slit Stl Slffmg	3
15		134 623	Bearing, Idler Roll	1
16		132 852	Arm, Pressure	1
17		605 798	Washer, Shldr Nyl .375 Od X .168 Id X .080	2
18		133 083	Spring, Tension Adj Drive Roll	1
19		144 860	Screw, Mach Stl Flh 8-32 X .437	1
20		058 968	Ring, Retainer E	1
21		135 474	Pin, Hinge	1
22		155 565	Screw, Thumb	1
		134 799	O-Ring, .176 Id X .070 Cs (Used W/Thumbscrew)	1
23		135 126	Screw, Set Stl Sch 6-32 X .125 Cup Point	1
24		135 580	Fitting, Gas	1

Item No.	Dia. Mkgs.	Part No.	Description	Quantity
Figure 8-4. Exploded View Of Gun (Continued)				
.. 25		112 896	.. Spring, Cprsn .240 Od X .020 Wire X .437	1
.. 26		135 773	.. Knob, Thumb Tension Adjusting 8-32	1
.. 27		143 360	.. Screw, Mach Stl Rdh 8-32 X .500	1
.. 28		136 679	.. Clamp, Strain Relief	1
.. 29		132 269	.. Screw, Mach Stl Rdhph 8-32 X .375	1
.. 30		214 743	.. Case, Gun Lh/Rh (Molded Halves)	1
.. 31		Deleted		
.. 32		Deleted		
.. 33		Deleted		
.. 34	B2	230 947	.. Motor, Gear Pm 24 VDC 420 RPM 10.2:1 Ratio W/Conn	1
.. 35		602 066	.. Screw, Mach Stl Trh 6-32 X .250	2
.. 36		164 592	.. Trigger	1
.. 37		058 262	.. Cap, Valve	1
.. 38	Fig 8-5	231 531	.. Head Tube Assy, (Air Cooled)	1
.. 38	Fig 8-5	231 532	.. Head Tube Assy, (Water Cooled)	1
.. 39		164 582	.. Housing, Wire Drive (15A & 30A Models) (Includes Items 24 & 37)	1
.. 39		164 581	.. Housing, Wire Drive (15W & 30W Models) (Includes Items 24 & 37)	1
..		151 661	.. Screw, Set 10-32 X .125 Cup Sch (30W Models Only)	2
.. 40		133 365	.. Clamp, Head Tube	1
.. 41		000 417	.. Screw, Cap Stl Sch 10-24 X 1.000	2
.. 42		203 758	.. Cable, Power (15A Model) (Consisting Of)	1
.. 42		203 759	.. Cable, Power (30A Model) (Consisting Of)	1
.. 43		133 362	.. Strain Relief, Cable	1
.. 44	R4	200 096	.. Potentiometer, C Slted Sft 1/T .5W 10K Ohm	1
.. 45		144 861	.. Washer, Anti-turn	1
.. 46		135 127	.. Lock, Shaft Pot .250-32 X .125Dia Shaft	1
.. 47		602 169	.. Screw, Set Stl Sch 8-32 X .187	1
.. 48		134 856	.. Knob, Speed Control 1-10 .140 Shaft X 1.125 Od	1
.. 49		Deleted		
.. 50	PB1	000 369	.. Switch, Lim 10A 125/250VAC Dpst Plgr	1
.. 51		183 884	.. Spring, Cprsn .240 Od X .026 Wire X 1.000	1
.. 52		184 101	.. Washer, Shldr .140 Id X .250 Od	1
.. 53		217 934	.. Screw, K40x 20 Pan Hd-trx Stl Pld Pt Thread Forming	4
.. 54		162 042	.. Contact, Current Pick-Up	1
.. 55		602 198	.. Washer, Lock .141 Id Stl Split	4
.. 56		134 624	.. Bearing, Flg Nyl .140 Id X .187 Od X .375Flg X .031Thk	2

To maintain the factory original performance of your equipment, use only Manufacturer's Suggested Replacement Parts. Model and serial number required when ordering parts from your local distributor.

Hardware is common and not available unless listed.

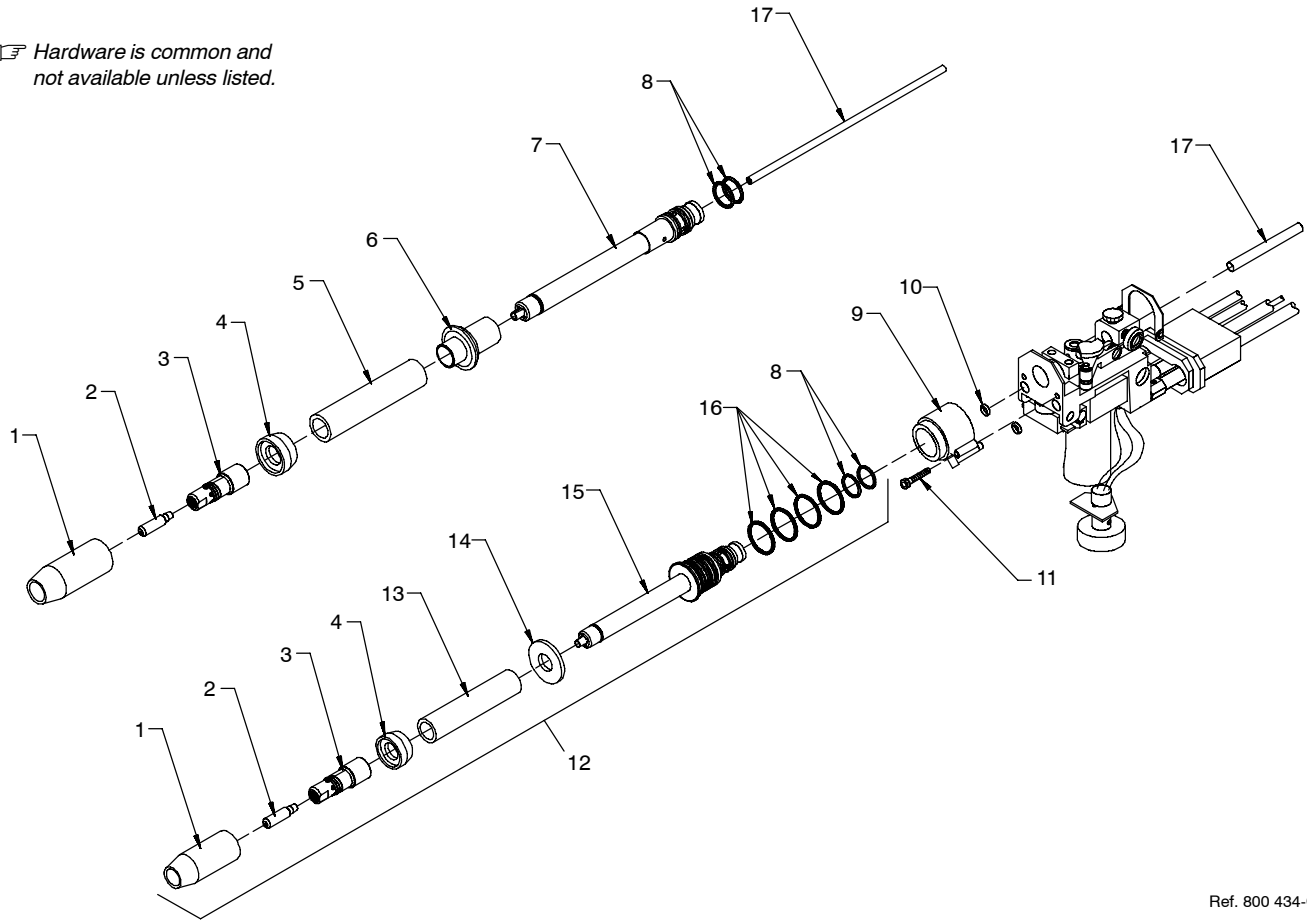

Ref. 800 434-G

Figure 8-5. Head Tube Assembly Of Pistol-Grip Gun

Item No.	Part No.	Description	Quantity
----------	----------	-------------	----------

Figure 8-5. Head Tube Assembly Of Pistol-Grip Gun (Figure 8-4 Item 15)

.. 1	199 613	.. Nozzle, Brass 5/8 In Orifice Tapered	1
.. 2 Tip, Fastip (See Section 9)	1
.. 3	227 749	.. Diffuser, .281/.312 Od Collar Fastip 1/8 Rec Edge	1
.. 4	232 284	.. Insulator, Nozzle Collared Diffuser	1
.. 5	219 794	.. Jacket, Outer Insulating	1
.. 6	219 795	.. Insulator, Barrel Pistol	1
.. 7	219 796	.. Head Tube, Air Pistol (Brazed)	1
.. 8	134 800	.. O-ring, .614 Id X .070cs	2
.. 9	203 675	.. Manifold, Water (15w & 30w Models) (Includes)	1
.. 10	175 946	.. O-ring, .614 Id X .070cs	2
.. 11	135 128	.. Screw, Cap Stl Sch 6-32 X 1.000 (15, 30w Models)	2
.. 12	231 532	.. Head Tube Assy, Water Cooled Pistol HD (15, 30w Models) (Includes) ..	1
.. 13	220 209	.. Jacket, Outer Insulating	1
.. 14	220 216	.. Washer, Flat .594idx1.375odx.125t Black Vulc Fbr	1
.. 15	220 210	.. Head Tube, Water Pistol (Brazed)	1
.. 16	180 966	.. O-ring, .926 Id X .070 Cs 70 Duro Quadring	4
.. 17	212 156	.. Liner, Phos Bronze .030-1/16 Wire X 7.313	1

To maintain the factory original performance of your equipment, use only Manufacturer's Suggested Replacement Parts. Model and serial number required when ordering parts from your local distributor.

SECTION 9 – PARTS LIST INCLUDING CONSUMABLES

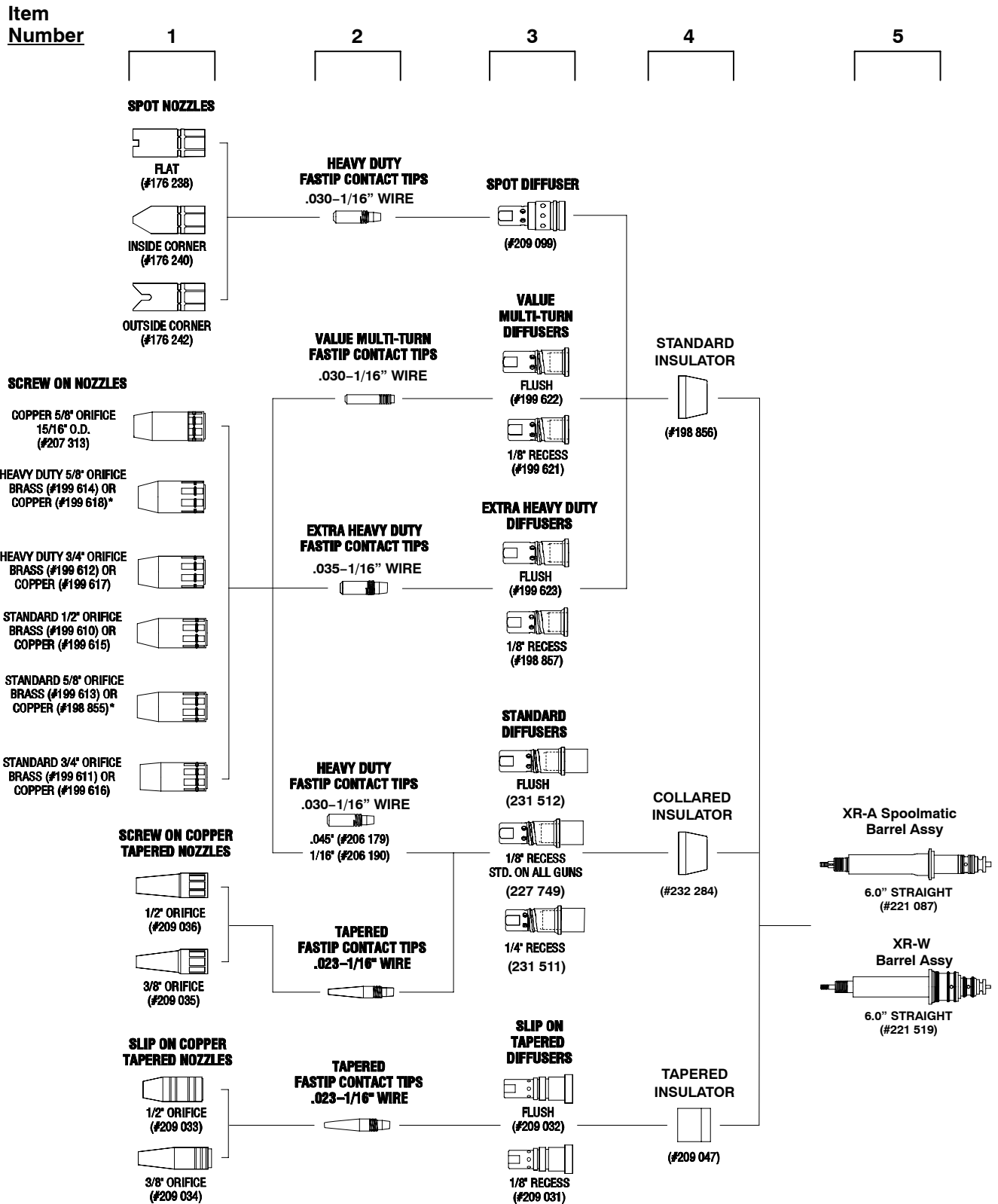

Ref. 803 909-A / 803 932 / 803 933 / 803 934

Figure 9-1. Consumables Flowchart For XR-A And XR-W Pistol Guns

Item No.	Part No.	Description	Quantity
----------	----------	-------------	----------

Figure 9-1. Consumables Flowchart

Table 9-1. Nozzles

...	1	◆176238	.. Nozzle, Spot Flat (Requires Diffuser 209099, Used With Any Heavy Duty FasTip™ Contact Tip)	1
...	1	◆176240	.. Nozzle, Spot Inside Corner (Requires Diffuser 209099, Used With Any Heavy Duty FasTip™ Contact Tip)	1
...	1	◆176242	.. Nozzle, Spot Outside Corner (Requires Diffuser 209099, Used With Any Heavy Duty FasTip™ Contact Tip)	1
...	1	◆199 610	.. Nozzle, Screw On Brass 1/2 In Orifice	1
...	1	◆199 611	.. Nozzle, Screw On Brass 3/4 In Orifice Straight	1
...	1	◆199 612	.. Nozzle, Screw On Brass 3/4 In Orifice Straight Heavy Duty	1
...	1	◆199 613	.. Nozzle, Screw On Brass 5/8 In Orifice	1
...	1	◆199 614	.. Nozzle, Screw On Brass 5/8 In Orifice Heavy Duty	1
...	1	◆199 615	.. Nozzle, Screw On Copper 1/2 In Orifice	1
...	1	◆199 616	.. Nozzle, Screw On Copper 3/4 In Orifice	1
...	1	◆199 617	.. Nozzle, Screw On Copper 3/4 In Orifice Heavy Duty	1
...	1	198 855	.. Nozzle, Screw On Copper 5/8 In Orifice	1
...	1	199 618	.. Nozzle, Screw On Copper 5/8 In Orifice Heavy Duty	1
...	1	◆207 313	.. Nozzle, Screw On Copper 5/8 In Orifice 15/16 OD	1
...	1	◆209 033	.. Nozzle, Slip On Copper 1/2 In Orifice Tapered (Requires Diffuser 209031 Or 209032 And Insulator 209047, Used With Any Tapered FasTip™ Contact Tip)	1
...	1	◆209 034	.. Nozzle, Slip On Copper 3/8 In Orifice Tapered (Requires Diffuser 209031 Or 209032 And Insulator 209047, Used With Any Tapered FasTip™ Contact Tip)	1
...	1	◆209 035	.. Nozzle, Screw On Copper 3/8 In Orifice Tapered (Requires Diffuser 227 747, 231 511 Or 231 512, Used With Any Tapered FasTip™ Contact Tip)	1
...	1	◆209 036	.. Nozzle, Screw On Copper 1/2 In Orifice Tapered (Requires Diffuser 227 747, 231 511 Or 231 512, Used With Any Tapered FasTip™ Contact Tip)	1

Table 9-2. Heavy Duty FasTip™ Contact Tips*

...	2	◆206 185	.. .030 in (0.8 mm)	1
...	2	◆206 186	.. .035 in (0.9 mm)	1
...	2	◆206 187	.. .040 in (1.0 mm) or .035 in (0.9 mm) Aluminum Wire	1
...	2	206 188	.. .045 in (1.2 mm)	1
...	2	◆206 189	.. .052 in (1.3 mm) or 3/64 in (1.2 mm) Aluminum Wire	1
...	2	206 190	.. 1/16 in (1.6 mm)	1
...	2	◆206 191	.. .068 in (1.7 mm) or 1/16 in (1.6 mm) Aluminum Wire	1

Table 9-3. Extra Heavy Duty FasTip™ Contact Tips*

...	2	◆199 605	.. .035 in (0.9 mm)	1
...	2	◆199 606	.. .040 in (1.0 mm) or .035 in (0.9 mm) Aluminum Wire	1
...	2	◆198 851	.. .045 in (1.2 mm)	1
...	2	◆198 852	.. .052 in (1.3 mm) or 3/64 in (1.2 mm) Aluminum Wire	1
...	2	◆198 853	.. 1/16 in (1.6 mm)	1
...	2	◆198 854	.. .068 in (1.7 mm) or 1/16 in (1.6 mm) Aluminum Wire	1

Table 9-4. Tapered FasTip™ Contact Tips*

...	2	◆209025	.. .030 in (0.8 mm)	1
...	2	◆209026	.. .035 in (0.9 mm)	1
...	2	◆209027	.. .045 in (1.2 mm)	1
...	2	◆209028	.. 3/64 in (1.2 mm)	1
...	2	◆209029	.. .052 in (1.3 mm)	1
...	2	◆209030	.. 1/16 in (1.6 mm)	1

Item No.	Part No.	Description	Quantity
----------	----------	-------------	----------

Figure 9-1. Consumables Flowchart (Continued)

Table 9-5. Value Multi-Turn Contact Tips*

... 2	◆071 825	.. .030 in (0.9 mm)	1
... 2	◆054 202	.. .035 in (0.9 mm)	1
... 2	◆054 201	.. .045 in (1.2 mm)	1
... 2	◆199 593	.. .3/64 in (1.2 mm) Aluminum Wire	1
... 2	◆044 006	.. .052 in (1.3 mm)	1
... 2	◆047 566	.. 1/16 in (1.6 mm)	1
... 2	◆202 933	.. 1/16 in (1.6 mm) Aluminum Wire	1

Table 9-6. Gas Diffusers

... 3	◆198 857	.. 1/8 in Tip Recess – For Extra Heavy Duty FasTip Contact Tips	1
... 3	◆199 623	.. Flush Tip – For Extra Heavy Duty FasTip Contact Tips	1
... 3	◆199 621	.. 1/8 in Tip Recess – For Value Multi-turn Contact Tips	1
... 3	◆199 622	.. Flush Tip – For Value Multi-turn Contact Tips	1
... 3	227 749	.. 1/8 in Tip Recess – For Heavy Duty FasTip Contact Tips (Standard On All Guns)	1
... 3	◆231 511	.. 1/4 in Tip Recess – For Heavy Duty FasTip Contact Tips	1
... 3	◆231 512	.. Flush Tip – For Heavy Duty FasTip Contact Tips	1
... 3	◆209 031	.. Slip On Recessed Diffuser (Requires Nozzle 209033 Or 209034 And Insulator 209047, Used With Any Tapered FasTip Contact Tip)	1
... 3	◆209 032	.. Slip On Flush Diffuser (Requires Nozzle 209033 Or 209034 And Insulator 209047, Used With Any Tapered FasTip Contact Tip)	1
... 3	◆209 099	.. Spot Diffuser (Requires Spot Nozzle 176238 Or 176240 Or 176242)	1

Table 9-7. Insulators

... 4	232 284	.. Insulator, Nozzle Collared Diffuser	1
... 4	198 856	.. Insulator, Rubber	1
... 4	209 047	.. Insulator, Teflon (Required When Using Diffuser 209031 Or 209032 With Nozzle 209033 Or 209034)	1

Table 9-8. Barrel Assemblies

... 5	221 087	.. Barrel Assy, Air Cooled Pistol	1
... 5	221 519	.. Barrel Assy, Water Cooled Pistol	1

Table 9-9. Head Tube Assemblies

.....	231 523	.. Kit, Head Tube Assy Air Cooled Pistol	1
.....	231 524	.. Kit, Head Tube Assy Water Cooled Pistol	1

◆OPTIONAL

*All contact tips are packaged in bags of 25.

BE SURE TO PROVIDE MODEL WHEN ORDERING REPLACEMENT PARTS.

To maintain the factory original performance of your equipment, use only Manufacturer's Suggested Replacement Parts. Model is required when ordering parts from your local distributor.

TRUE BLUE[®]

WARRANTY

Effective January 1, 2007

(Equipment with a serial number preface of "LH" or newer)

This limited warranty supersedes all previous Miller warranties and is exclusive with no other guarantees or warranties expressed or implied.

LIMITED WARRANTY – Subject to the terms and conditions below, Miller Electric Mfg. Co., Appleton, Wisconsin, warrants to its original retail purchaser that new Miller equipment sold after the effective date of this limited warranty is free of defects in material and workmanship at the time it is shipped by Miller. THIS WARRANTY IS EXPRESSLY IN LIEU OF ALL OTHER WARRANTIES, EXPRESS OR IMPLIED, INCLUDING THE WARRANTIES OF MERCHANTABILITY AND FITNESS.

Within the warranty periods listed below, Miller will repair or replace any warranted parts or components that fail due to such defects in material or workmanship. Miller must be notified in writing within thirty (30) days of such defect or failure, at which time Miller will provide instructions on the warranty claim procedures to be followed.

Miller shall honor warranty claims on warranted equipment listed below in the event of such a failure within the warranty time periods. All warranty time periods start on the delivery date of the equipment to the original end-user purchaser, and not to exceed one year after the equipment is shipped to a North American distributor or eighteen months after the equipment is shipped to an International distributor.

1. 5 Years Parts — 3 Years Labor
 - * Original main power rectifiers
2. 3 Years — Parts and Labor
 - * Transformer/Rectifier Power Sources
 - * Plasma Arc Cutting Power Sources
 - * Process Controllers
 - * Semi-Automatic and Automatic Wire Feeders
 - * Inverter Power Sources (Unless Otherwise Stated)
 - * Water Coolant Systems (Integrated)
 - * Intellitig
 - * Engine Driven Welding Generators
(NOTE: Engines are warranted separately by the engine manufacturer.)
3. 1 Year — Parts and Labor Unless Specified
 - * Motor Driven Guns (w/exception of Spoolmate Spoolguns)
 - * Positioners and Controllers
 - * Automatic Motion Devices
 - * RFCS Foot Controls
 - * Induction Heating Power Sources, Coolers, and Electronic Controls/Recorders
 - * Water Coolant Systems (Non-Integrated)
 - * Flowgauge and Flowmeter Regulators (No Labor)
 - * HF Units
 - * Grids
 - * Spot Welders
 - * Load Banks
 - * Arc Stud Power Sources & Arc Stud Guns
 - * Racks
 - * Running Gear/Trailers
 - * Plasma Cutting Torches (except APT & SAF Models)
 - * Field Options
(NOTE: Field options are covered under True Blue[®] for the remaining warranty period of the product they are installed in, or for a minimum of one year — whichever is greater.)
 - * Bernard-Branded Mig Guns (No Labor)
 - * Weldcraft-Branded TIG Torches (No Labor)
 - * Subarc Wire Drive Assemblies
4. 6 Months — Batteries
5. 90 Days — Parts
 - * MIG Guns/TIG Torches and Subarc (SAW) Guns

- * Induction Heating Coils and Blankets, Cables, and Non-Electronic Controls
- * APT & SAF Model Plasma Cutting Torches
- * Remote Controls
- * Accessory (Kits)
- * Replacement Parts (No labor)
- * Spoolmate Spoolguns
- * Canvas Covers

Miller's True Blue[®] Limited Warranty shall not apply to:

1. **Consumable components; such as contact tips, cutting nozzles, contactors, brushes, slip rings, relays or parts that fail due to normal wear. (Exception: brushes, slip rings, and relays are covered on Bobcat, Trailblazer, and Legend models.)**
2. Items furnished by Miller, but manufactured by others, such as engines or trade accessories. These items are covered by the manufacturer's warranty, if any.
3. Equipment that has been modified by any party other than Miller, or equipment that has been improperly installed, improperly operated or misused based upon industry standards, or equipment which has not had reasonable and necessary maintenance, or equipment which has been used for operation outside of the specifications for the equipment.

MILLER PRODUCTS ARE INTENDED FOR PURCHASE AND USE BY COMMERCIAL/INDUSTRIAL USERS AND PERSONS TRAINED AND EXPERIENCED IN THE USE AND MAINTENANCE OF WELDING EQUIPMENT.

In the event of a warranty claim covered by this warranty, the exclusive remedies shall be, at Miller's option: (1) repair; or (2) replacement; or, where authorized in writing by Miller in appropriate cases, (3) the reasonable cost of repair or replacement at an authorized Miller service station; or (4) payment of or credit for the purchase price (less reasonable depreciation based upon actual use) upon return of the goods at customer's risk and expense. Miller's option of repair or replacement will be F.O.B., Factory at Appleton, Wisconsin, or F.O.B. at a Miller authorized service facility as determined by Miller. Therefore no compensation or reimbursement for transportation costs of any kind will be allowed.

TO THE EXTENT PERMITTED BY LAW, THE REMEDIES PROVIDED HEREIN ARE THE SOLE AND EXCLUSIVE REMEDIES. IN NO EVENT SHALL MILLER BE LIABLE FOR DIRECT, INDIRECT, SPECIAL, INCIDENTAL OR CONSEQUENTIAL DAMAGES (INCLUDING LOSS OF PROFIT), WHETHER BASED ON CONTRACT, TORT OR ANY OTHER LEGAL THEORY.

ANY EXPRESS WARRANTY NOT PROVIDED HEREIN AND ANY IMPLIED WARRANTY, GUARANTY OR REPRESENTATION AS TO PERFORMANCE, AND ANY REMEDY FOR BREACH OF CONTRACT TORT OR ANY OTHER LEGAL THEORY WHICH, BUT FOR THIS PROVISION, MIGHT ARISE BY IMPLICATION, OPERATION OF LAW, CUSTOM OF TRADE OR COURSE OF DEALING, INCLUDING ANY IMPLIED WARRANTY OF MERCHANTABILITY OR FITNESS FOR PARTICULAR PURPOSE, WITH RESPECT TO ANY AND ALL EQUIPMENT FURNISHED BY MILLER IS EXCLUDED AND DISCLAIMED BY MILLER.

Some states in the U.S.A. do not allow limitations of how long an implied warranty lasts, or the exclusion of incidental, indirect, special or consequential damages, so the above limitation or exclusion may not apply to you. This warranty provides specific legal rights, and other rights may be available, but may vary from state to state.

In Canada, legislation in some provinces provides for certain additional warranties or remedies other than as stated herein, and to the extent that they may not be waived, the limitations and exclusions set out above may not apply. This Limited Warranty provides specific legal rights, and other rights may be available, but may vary from province to province.

miller_warr 2007-01

Warranty Questions?

Call
1-800-4-A-MILLER
for your local
Miller distributor.

Your distributor also gives you ...

Service

You always get the fast, reliable response you need. Most replacement parts can be in your hands in 24 hours.

Support

Need fast answers to the tough welding questions? Contact your distributor. The expertise of the distributor and Miller is there to help you, every step of the way.





Owner's Record

Please complete and retain with your personal records.

Model Name

Serial/Style Number

Purchase Date

(Date which equipment was delivered to original customer.)

Distributor

Address

City

State

Zip



For Service

Contact a DISTRIBUTOR or SERVICE AGENCY near you.

Always provide Model Name and Serial/Style Number.

Contact your Distributor for:

Welding Supplies and Consumables

Options and Accessories

Personal Safety Equipment

Service and Repair

Replacement Parts

Training (Schools, Videos, Books)

Technical Manuals (Servicing Information and Parts)

Circuit Diagrams

Welding Process Handbooks

To locate a Distributor or Service Agency visit www.millerwelds.com or call 1-800-4-A-Miller

Contact the Delivering Carrier to:

File a claim for loss or damage during shipment.

For assistance in filing or settling claims, contact your distributor and/or equipment manufacturer's Transportation Department.

Miller Electric Mfg. Co.

An Illinois Tool Works Company
1635 West Spencer Street
Appleton, WI 54914 USA

International Headquarters—USA

USA Phone: 920-735-4505 Auto-Attended
USA & Canada FAX: 920-735-4134
International FAX: 920-735-4125

European Headquarters – United Kingdom

Phone: 44 (0) 1204-593493
FAX: 44 (0) 1204-598066

www.MillerWelds.com

