



Disk On-line Server

QNAP Systems, Inc.

NAS-2100

User Manual

Broadband Network Attached Storage

NAS-2100

User Manual (Version: 4.1.4)



©Copyright 2005. QNAP Systems, Inc. All Rights Reserved.
March 29, 2005

CUSTOMER SERVICE

For the contact details of customer service and technical support, please refer to the registration card.

LIMITED WARRANTY

In no event shall the liability of QNAP Systems, Inc. (QNAP) exceed the price paid for the product from direct, indirect, special, incidental, or consequential software, or its documentation. QNAP offers no refunds for its products. QNAP makes no warranty or representation, expressed, implied, or statutory, with respect to its products or the contents or use of this documentation and all accompanying software, and specifically disclaims its quality, performance, merchantability, or fitness for any particular purpose. QNAP reserves the right to revise or update its products, software, or documentation without obligation to notify any individual or entity.

CAUTION

1. Back up your system periodically to avoid any potential data loss.
2. Should you return any components of Disk On-line Server package for refund or maintenance, make sure they are carefully packed for shipping. Any form of damages due to improper packaging will not be compensated.

Table of Contents

Chapter 1 Overview of Disk On-line Server	6
1.1 Introduction	6
1.2 Package Contents.....	6
1.3 System Overview	7
Chapter 2 Installation of Disk On-line Server.....	8
2.1 Network Configuration	8
Chapter 3 Administration of Disk On-line Server.....	9
3.1 Accessing Administration Page	9
3.2 Server Administration	11
3.3 Quick Configuration	12
3.4 System Settings.....	18
3.5 Network Settings	21
3.6 Disk Configuration.....	29
3.7 User Management	33
3.8 Network Share Management.....	37
3.9 System Tools	41
3.9.1 <i>SNMP Settings</i>	41
3.9.2 <i>Alert Notification</i>	42
3.9.3 <i>Restart/ Shutdown</i>	42
3.9.4 <i>Hardware Settings</i>	43
3.9.5 <i>UPS</i>	44
3.9.6 <i>System Update</i>	45
3.9.7 <i>Change Logo</i>	46
3.9.8 <i>Remote Replication</i>	47
3.9.9 <i>Virus Scan</i>	51
3.9.10 <i>Backup/ Restore/ Reset Settings</i>	56
3.9.11 <i>Backup Agent</i>	57
3.10 Statistics & Logs.....	60
Chapter 4 Accessing Disk On-line Server	61
4.1 Using Microsoft Windows.....	61
4.2 Using Apple MAC OS.....	63
4.3 Using Unix/ Linux OS.....	69
4.4 Netware Service.....	69
4.5 Using Web Browser	69
4.6 Using File Transfer Protocol (FTP)	70
Chapter 5 Disk On-line Server-Maintenance.....	72

5.1	Restart/ Shut down Server	72
5.2	Reset Administrator Password and Network Settings	72
5.3	Disk Failure or Malfunction.....	73
5.4	Power Outage or Abnormal Shutdown	73
Appendix A	LCD Panel.....	74
Appendix B	Web File Manager	77
Appendix C	Quick Install Wizard.....	82
Appendix D	NetBak Replicator	91
Appendix E	Configuring AD Authentication.....	102
Appendix F	Messages of Hard Disk and Disk Configuration Status ...	111

Chapter 1 Overview of Disk On-line Server

1.1 Introduction

Thank you for choosing Disk On-line Server (NAS). This product has the following key features:

- Desktop/ Rack-mount dual form factor design
- VIA Eden 400MHz/ 128MB DRAM
- 2 x 3.5" IDE HDD
- Maximum capacity up to 600GB
- Supports RAID 0, 1 and JBOD storage management
- 10/100 Mbps fast Ethernet port
- Supports UPS management via USB port

1.2 Package Contents

Your NAS package contains:

- Disk On-line Server (stands inclusive)
- Power cable
- CAT-5 Ethernet cable
- Companion CD (user manual, Quick Install Wizard and software inclusive)
- Quick Installation Guide

Important Notice: Please back up your disk data periodically to avoid data loss due to improper operation or disk failure of Disk On-line Server.

1.3 System Overview

Front View

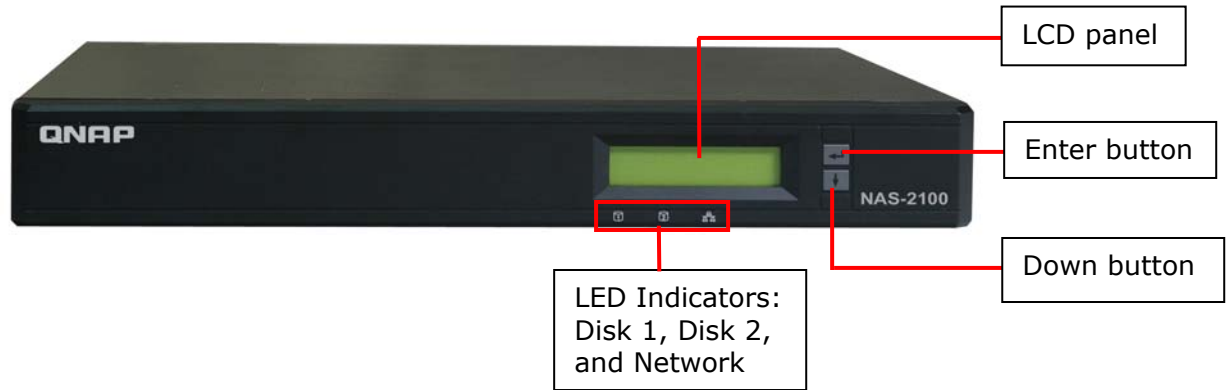

Rear View

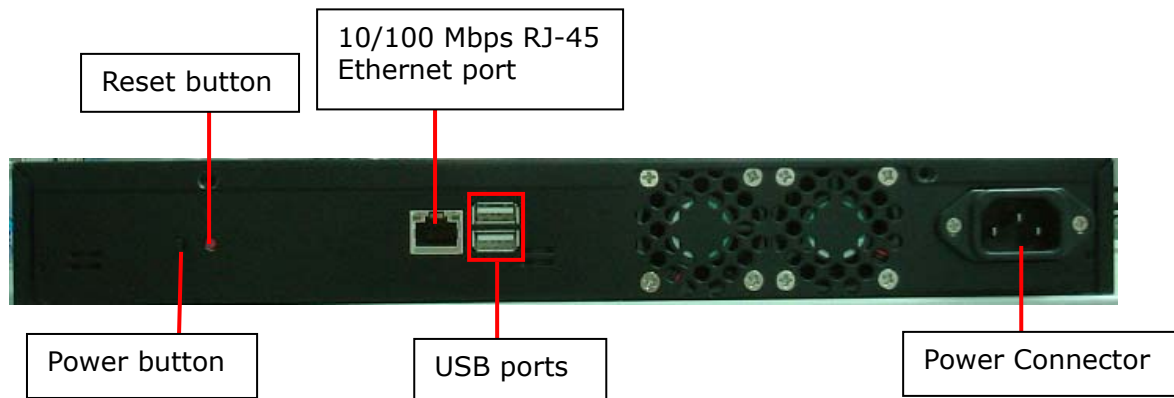

Chapter 2 Installation of Disk On-line Server

2.1 Network Configuration

By factory default, Disk On-line Server will search the network via DHCP (Dynamic Host Configuration Protocol) to detect IP address settings automatically. If your network does not support DHCP protocol, Disk On-line Server will use the default settings as below:

IP Address: **192.168.0.1**

Subnet Mask: **255.255.255.0**

When Disk On-line Server completes its boot-up process, the LCD panel will display current IP address settings.

If your network does not support DHCP protocol, you must configure your Disk On-line Server to proper LAN settings before using it for the first time. (If you are not sure about the LAN settings, please contact your network administrator).

You can change the network settings of Disk On-line Server by the following ways:

1. Use the LCD panel to change the network settings. For more information, please refer to Appendix A.
2. Use Quick Install Wizard in the companion CD to change the network settings. For more information, please refer to Appendix C.

Chapter 3 Administration of Disk On-line Server

When you have installed Disk On-line Server and connected it to the network, you can manage the server via web browser. Disk On-line Server supports Microsoft Internet Explorer 5.0 or later, and Netscape Navigator 4.5 or later. Microsoft Internet Explorer 5.5 is recommended.

3.1 Accessing Administration Page

1. Launch the web browser. Enter the IP address of Disk On-line Server to access the administration page. The IP address can also be obtained on the LCD display of Disk On-line Server (see Appendix A).
2. Run Quick Installation Wizard (see Appendix C) and double-click on an entry on the list.

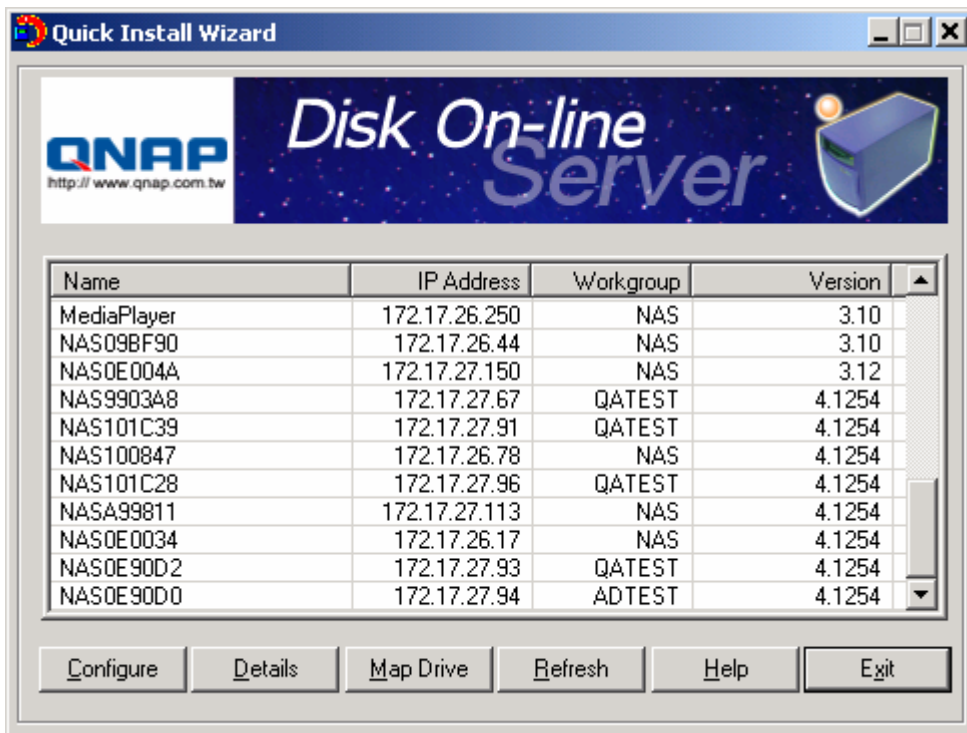

3. Click **Administration** on the main page.



4. Enter the user name and password.

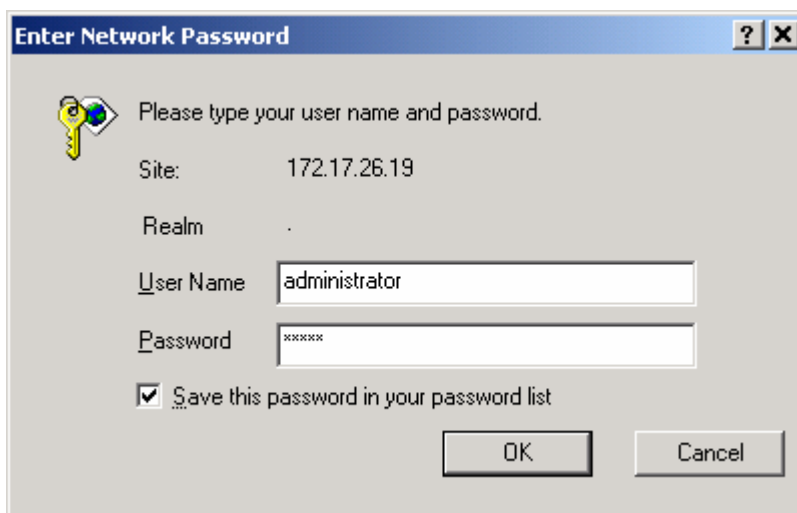

The default administrator name and password are:

User name: **administrator**

Password: **admin**

The first time you login Disk On-line Server, Quick Configuration page will be shown. Please refer to the Quick Configuration section for more details.

3.2 Server Administration

There are eight main sections in server administration, which are listed below:

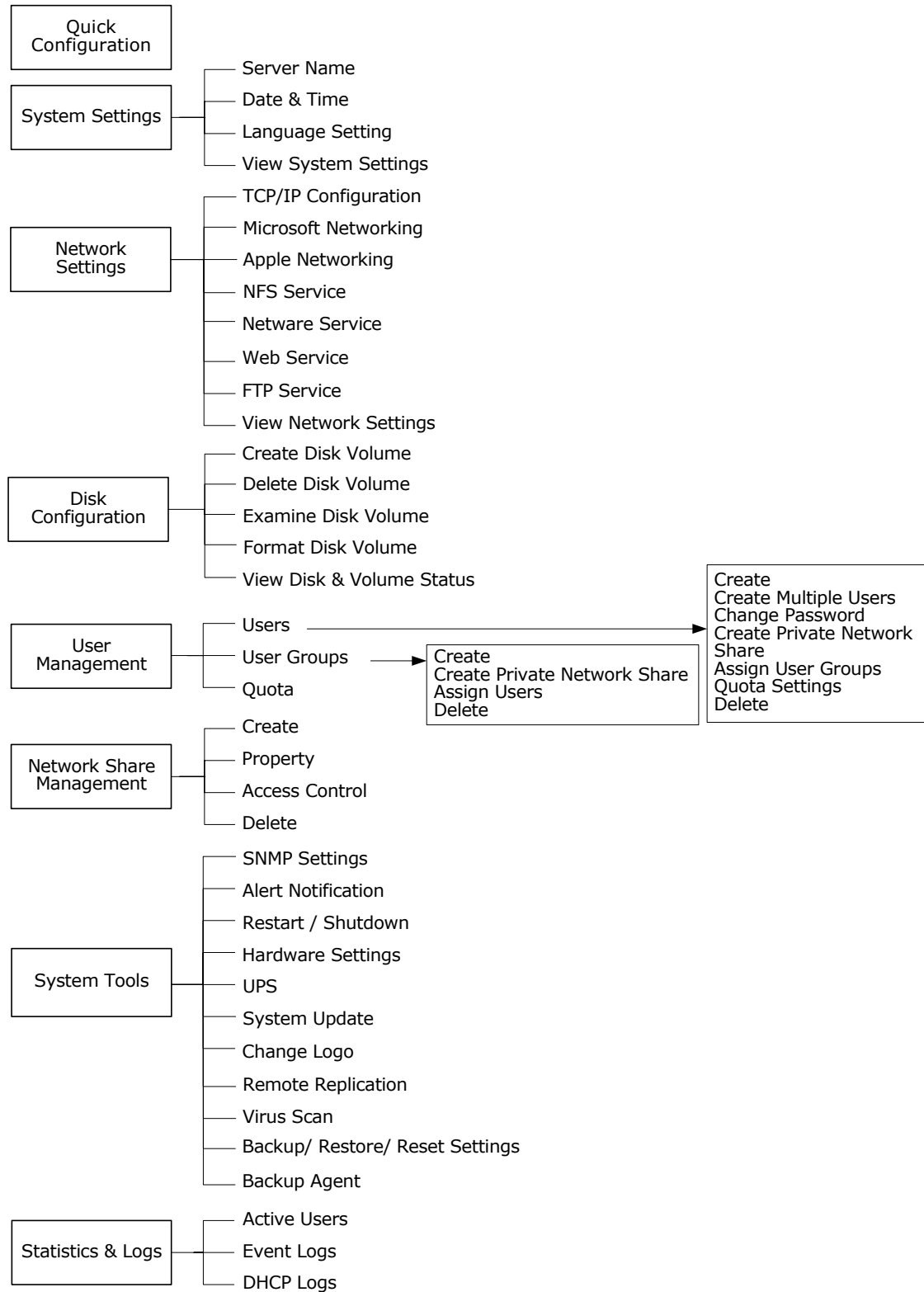

3.3 Quick Configuration

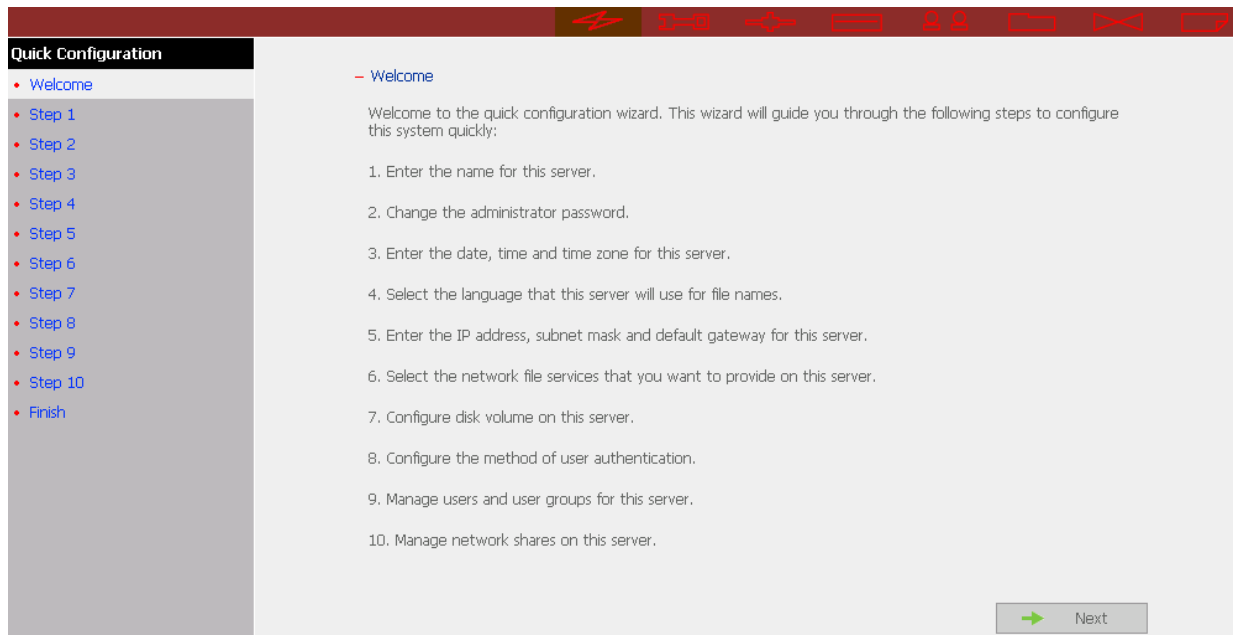

You can configure Disk On-line Server step by step in Quick Configuration section.

1. Enter the server name.

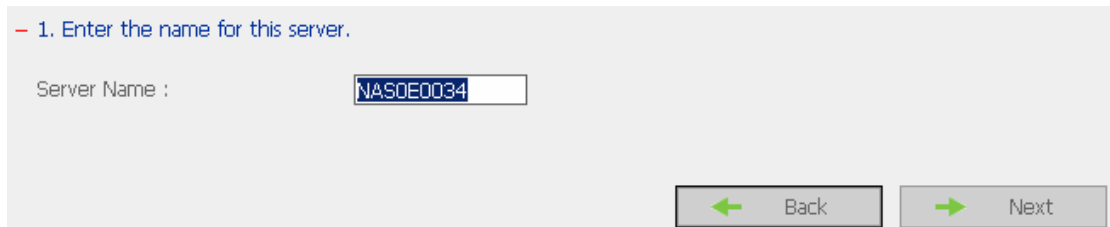

2. Change the administrator password or select to use the original password.

- 2. Change the administrator password.

Password :

Verify Password :

Use the original password

Note: If you select "Use the original password", the administrator password will not be changed.

3. Enter the date, time and select the time zone for the server.

- 3. Enter the date, time and time zone for this server.

Time Zone :

Current date and time:

Change the server's time and date as below:

Date: , (mm dd, yyyy)

Time: : : (hh:mm:ss)

4. Select the language the server uses for file names.

- 4. Select the language that this server will use for file names.

Language:

- Chinese-Simplified
- Chinese-Traditional
- Cyrillic
- Greek
- Icelandic
- Japanese
- Korean
- Slavic/Latin 2
- English
- Western Europe/Latin 1

5. Enter the IP address, subnet mask and default gateway for the server.

– 5. Enter the IP address, subnet mask and default gateway for this server.

Obtain TCP/IP settings automatically via DHCP

Use the following settings

IP Address: . . .

Subnet Mask: . . .

Default Gateway: . . .

Note: If you don't need a default gateway for this server, please enter "0.0.0.0".

6. Select the network file services to provide on the server.

– 6. Select the network file services you want to provide on this server.

Enable File Service for Microsoft Networking

Enable AppleTalk File Service for Apple Networking

Enable NFS Service

Enable NetWare Service

Enable Web File Manager

Enable FTP Service

7. Configure disk volume on this server.

- 7. Configure disk volume on this server.

You can click on the disk volume you want to configure on the **New Disk Volume Configuration** list. The **Current Disk Volume Configuration** list shows the current disk volume configuration of this server.

New Disk Volume Configuration

 **Single Disk Volume**
Create single disk volume(s).

 **RAID 1 Mirroring Disk Volume**
Create mirroring disk volume(s).

 **RAID 0 Striping Disk Volume**
Create one striping disk volume.

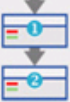
 **Linear Disk Volume**
Create one linear disk volume.

Current Disk Volume Configuration

Volume	Total Size	Free Size	Status
Mirroring Disk Volume: Drive 1 2	37879.00 MB	37135.00 MB	Ready

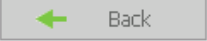
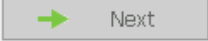
 Back  Next

8. Configure the method of user authentication.

- 8. Configure the method of user authentication.

Enable file service for Microsoft networking

Standalone Server

NT Domain Member

AD Domain Member

Server Description

Workgroup

Domain Name

Domain Username

Password

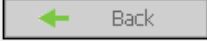
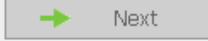
 Back  Next

9. Manage users and user groups of this server.

– 9 Manage users of this server.

To add a user, enter the user information in the following fields, then click Add. To remove an existing user, click on the user name on the left list and click Remove. You can remove multiple users at a time.

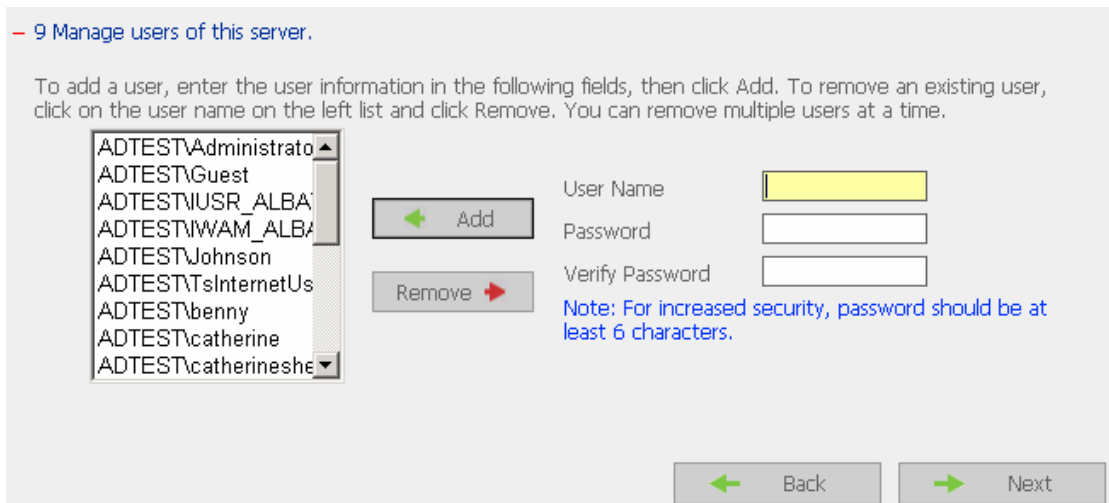

ADTEST\Administrato
ADTEST\Guest
ADTEST\USR_ALBA
ADTEST\WAM_ALBA
ADTEST\Johnson
ADTEST\tsInternetUs
ADTEST\benny
ADTEST\catherine
ADTEST\catherineshe

← Add

Remove →

User Name

Password

Verify Password

Note: For increased security, password should be at least 6 characters.

← Back → Next

– 9.1 Set user groups of this server.

To add a user group, enter the group name in the box below. Select the user(s) to add to the group from the list on the right, then click Add. To remove a user group, select the group name on the left list, and click Remove. You can remove multiple user groups at a time.

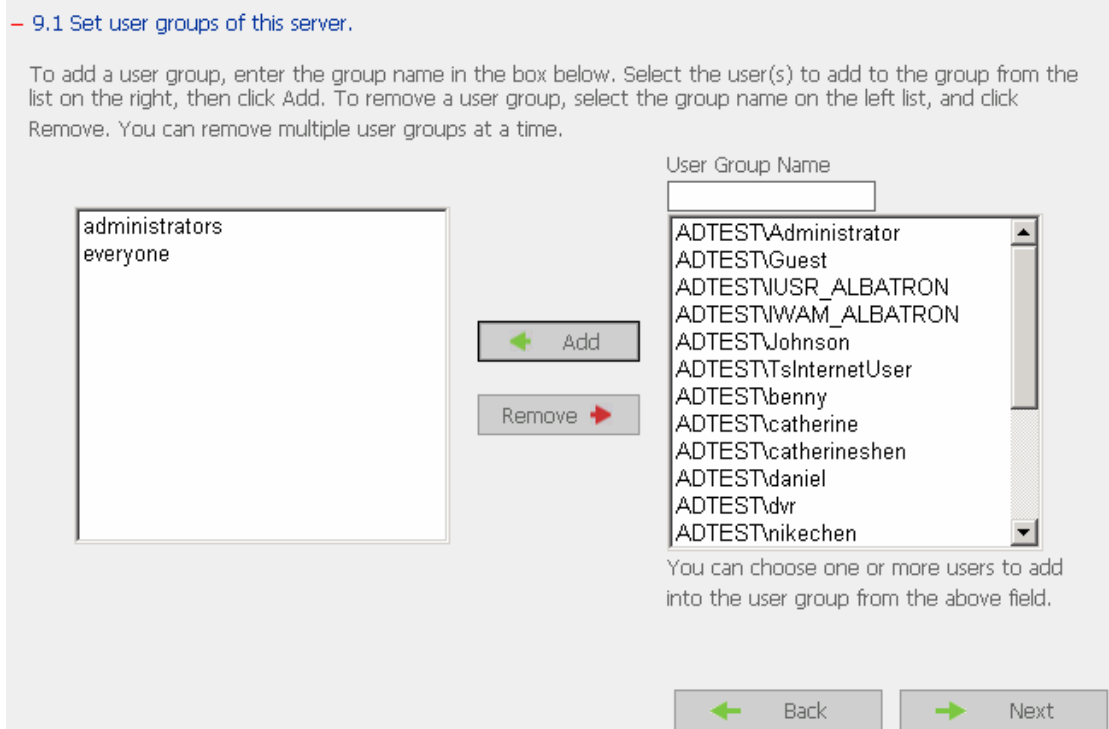

administrators
everyone

← Add

Remove →

User Group Name

ADTEST\Administrator
ADTEST\Guest
ADTEST\USR_ALBATRON
ADTEST\WAM_ALBATRON
ADTEST\Johnson
ADTEST\tsInternetUser
ADTEST\benny
ADTEST\catherine
ADTEST\catherineshen
ADTEST\daniel
ADTEST\dvr
ADTEST\nikechen

You can choose one or more users to add into the user group from the above field.

← Back → Next

10. Manage network shares on this server.

– 10. Manage network shares on this server.

To add a network share, enter the network share information in the fields on the right below, then click Add.
To remove an existing network share, select the network share on the left list, and click Remove.

public		Network Share Name	<input type="text"/>
	<input type="button" value="← Add"/>	Volume	<input type="text" value="Mirroring Disk Volume: Drive12"/>
	<input type="button" value="Remove →"/>	Comment	<input type="text"/>

11. Finish.

– Finish

Congratulations. You have finished all the steps for Quick Configuration.

To start using the server, click Finish. Or you can click Back to make more changes to the settings.

It may take several to tens of minutes to complete Quick Configuration, depending on your system settings.

3.4 System Settings

Basic system settings include the server name, date, time, language settings, and view system settings.

- **Server Name**

Enter the name of Disk On-line Server. The server name can be 14 characters long at maximum, which can contain alphabets, numbers and hyphens (-). The server does not accept names containing empty characters, period (.), or names with only numbers.

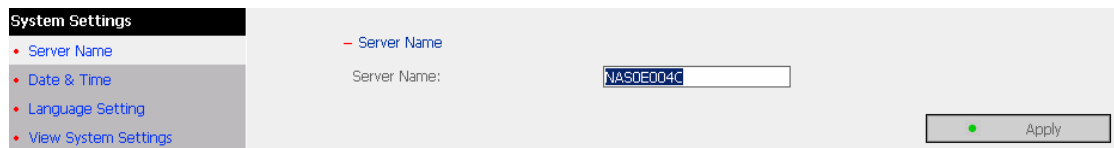

The screenshot shows a web-based system settings interface. On the left, there is a sidebar menu titled "System Settings" with four items: "Server Name", "Date & Time", "Language Setting", and "View System Settings". The "Server Name" item is selected and highlighted. The main content area on the right is titled "Server Name" and contains a label "Server Name:" followed by a text input field containing the value "NAS0E004C". To the right of the input field is an "Apply" button with a green dot icon.

- **Date & Time**

Set the date, time, and time zone according to your location. If the settings are incorrect, the following problems may occur:

- ✓ When using a web browser to access or save a file, the display time of the action will be incorrect.
- ✓ The system event log time will be incorrect compared to the actual time when an action occurs.

- Adjust the date, time and time zone of this server

Time Zone: (GMT+08:00) Taipei

Current date and time: 2004 / 9 / 9 AM 10 : 21 : 34

Change date and time manually

Date: January , (mm dd, yyyy)

Time: : : AM (hh:mm:ss)

Configure NTP server or client setting

Use the specified NTP server

IP Address of NTP Server: [] Test (Status: --)

Time Interval: 1 minute(s)

Enable NTP server

NTP Server #1: [] Test (Status: --)

NTP Server #2: [] Test (Status: --)

NTP Server #3: [] Test (Status: --)

Apply

- ✓ **NTP Server**

You can enable or use specified NTP server to update the date and time of the system automatically. When there is no specified IP address for the NTP server, the system will refer to internal clock for date and time settings.

- **Language Setting**

Disk On-line Server will use the language specified in this section to create and display files and directories. Select the correct language to avoid the following problems:

- i. Unable to create files or directories in special characters.
- ii. Unable to display file or directory name in special characters.

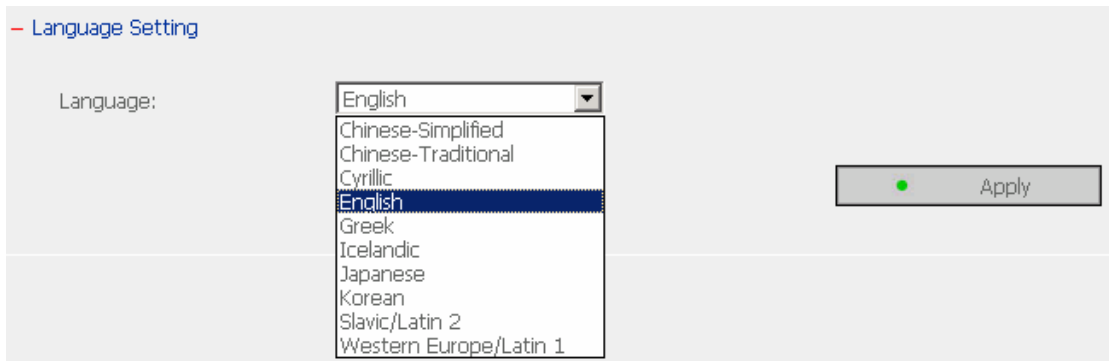

- **View System Settings**

You can view all current system settings, e.g. server name, on this page.



3.5 Network Settings

1. TCP/IP Configuration

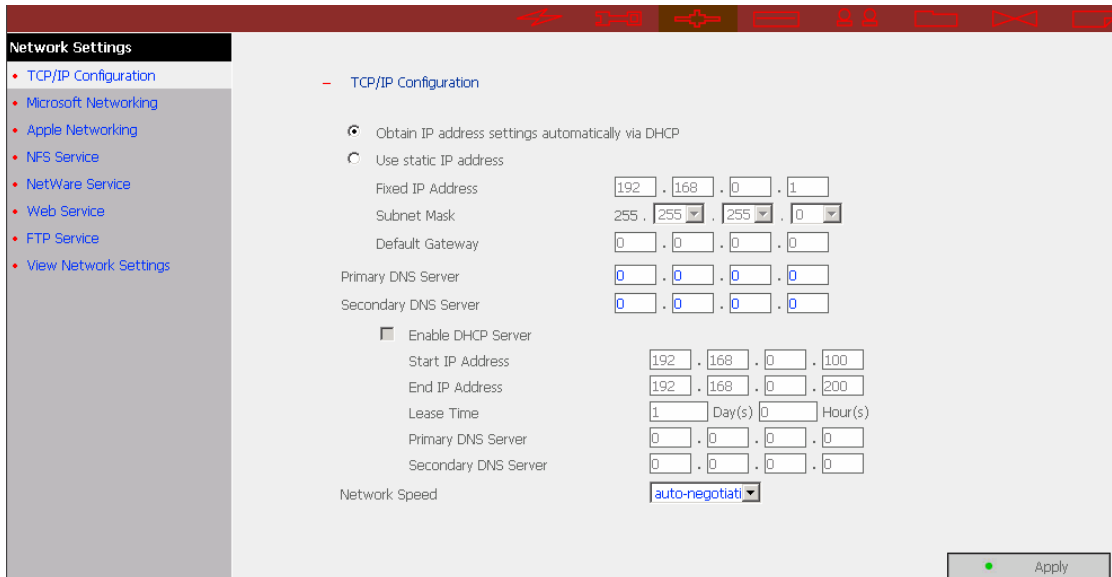

- **Obtain IP address settings automatically via DHCP**

If your network supports DHCP, Disk On-line Server will automatically use DHCP protocol to retrieve the IP address and related information.

- **Use static IP address**

To use fixed IP address for network connection, enter the following information:

- ✓ **Fixed IP Address**

IP address is a 32-bit digit used to differentiate each single entity on a network. IP address is divided into four groups of eight bits separated by dots, e.g. 192.168.0.1.

- ✓ **Subnet Mask**

Subnet mask defines computers within the same local network. It is a 32-bit digit, e.g. 255.xxx.xxx.xxx.

- ✓ **Default Gateway**

Gateway is generally referred to an interchange point that connects two networks, such as LAN and WAN.

Primary DNS Server: Enter the IP address of primary DNS server that provides DNS service for NAS in external network.

Secondary DNS Server: Enter the IP address of secondary DNS server that provides DNS service for NAS in external network.

You can also configure the following settings:

- ✓ Enable DHCP server
If there is no DHCP server on your network, you can enable this option to provide IP address settings to the clients.
- ✓ Start IP address
The first IP address to be dynamically allocated for DHCP service.
- ✓ End IP address
The last IP address to be dynamically allocated for DHCP service.
- ✓ Lease time
Define the lease time for the dynamic IP address.
- ✓ Primary DNS server
When the system allocates an IP address to your computer, the primary DNS server address is also specified to it.
- ✓ Secondary DNS Server
When the system allocates an IP address to your computer, the secondary DNS server address is also specified to it.

Network Speed

Network speed settings provide an advanced option for configuring network speed. You can select auto-negotiation to determine network speed automatically. It is recommended to use the default setting.

2. Microsoft Networking

Microsoft Networking

Enable file service for Microsoft networking

Standalone Server

NT Domain Member

AD Domain Member

Server Description:

Workgroup:

Domain Name:

Domain Username:

Password:

Enable WINS server

Use the specified WINS server

WINS server IP address:

Enable file service for Microsoft networking: For users using Microsoft Windows, enable this service to access the files on network share folders. Assign a workgroup name. The name can be 15 characters long at maximum but must not include the following:

" + = [] , ; / \ : | * ? < > . "

Note: The first character cannot be a period (.).

✓ **Standalone Server**

Use local users for user authentication.

✓ **NT Domain Member**

Use Microsoft NT domain for user authentication.

✓ **AD Domain Member**

Use Microsoft AD domain for user authentication.

- **Server Description:** Describe Disk On-line Server, e.g. administrator name, department, or location of the server, for users to identify the server. Users using Disk On-line Server on the Microsoft Windows operating systems must enable Microsoft Network Services.

- Workgroup: When configuring Disk On-line Server as standalone server, specify the workgroup the server belongs to. The workgroup is a computer group unit in Microsoft Windows network for network sharing.
- Domain Name: Microsoft domain name. Enter the domain name when you select NT domain or AD domain.

If the local network has a WINS server installed, specify the IP address. Disk On-line Server will automatically register its name and IP address with WINS service. If you do not want to enable WINS server support, or you do not have a WINS server on your network, enter 0.0.0.0 in the field for WINS server IP address.

The screenshot shows a configuration window with a light gray background. It contains two unchecked checkboxes: "Enable WINS server" and "Use the specified WINS server". Below the second checkbox is a text label "WINS server IP address" followed by four small input boxes separated by commas, each containing the digit "0". In the bottom right corner, there is a button with a green dot icon and the text "Apply".

3. Apple Network

To use Disk On-line Server on Apple MAC operating system, enable AppleTalk network support.

If your AppleTalk network uses extended networks, and is assigned with multiple zones, assign a zone name to Disk On-line Server. If you do not want to assign a network zone, enter an asterisk (*) to use the default setting.

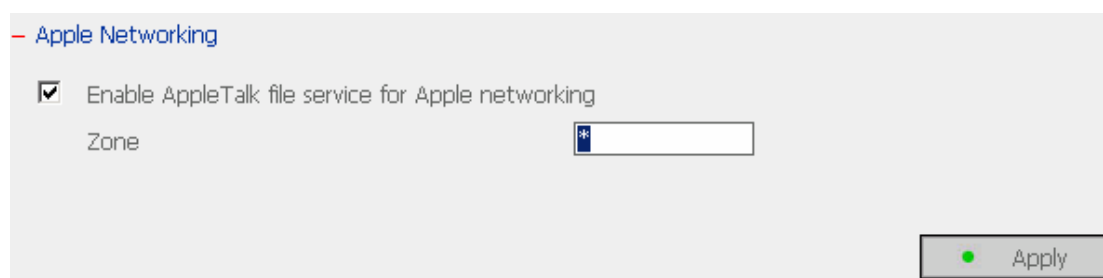

4. NFS Service

To use Disk On-line Server on Unix/ Linux operating system computer or server, enable NFS service. Disk On-line Server supports NFS version 2.0 and 3.0. To correctly use NFS service, assign a user's UID and IP address. Go to NFS Settings in Users of User Management for setup. When you have completed the configuration, login the system as root and use mount command to connect to the network. You can then login with other identities and access Disk On-line Server using previous NFS settings.

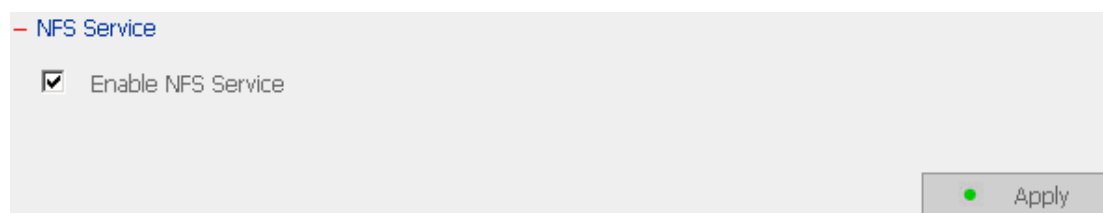

5. NetWare Service

To use Novell Netware service, enable this option and enter the server name for Netware network. The server will then operate in a manner similar to a Novell NetWare 3.12 file server.

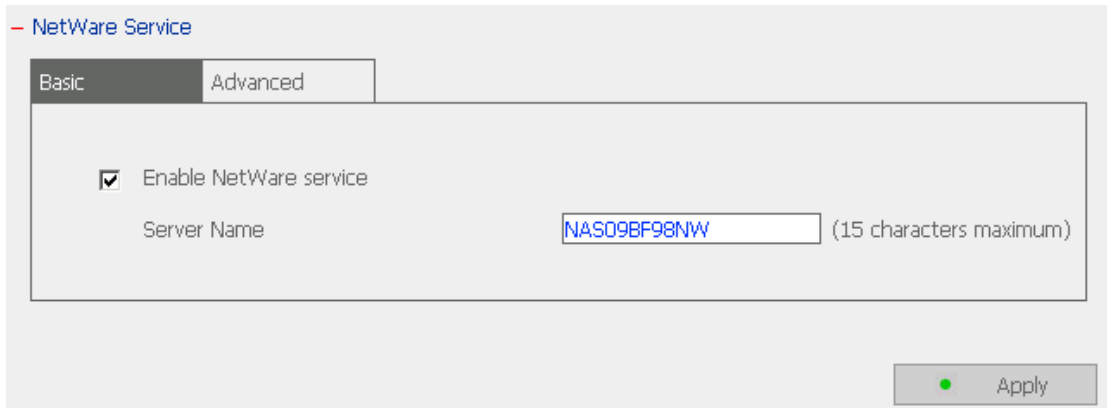

The screenshot shows the 'NetWare Service' configuration window with the 'Basic' tab selected. The 'Enable NetWare service' checkbox is checked. The 'Server Name' field contains the text 'NAS09BF98NW' and is followed by the text '(15 characters maximum)'. An 'Apply' button is visible in the bottom right corner.

To configure more options for Netware service, enable Netware service and click **Advanced**.

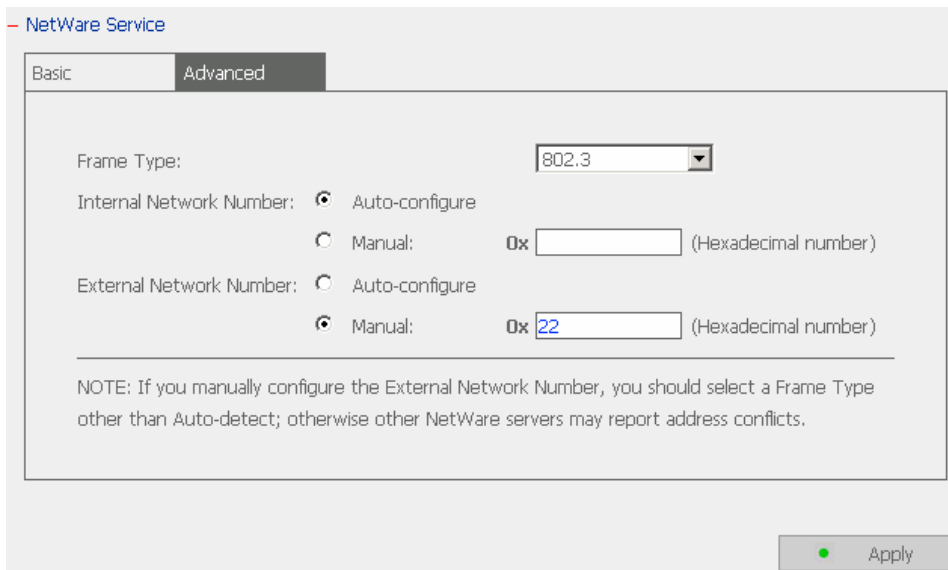

The screenshot shows the 'NetWare Service' configuration window with the 'Advanced' tab selected. The 'Frame Type' dropdown menu is set to '802.3'. The 'Internal Network Number' section has 'Auto-configure' selected. The 'External Network Number' section has 'Manual' selected, with the value '22' entered in the '0x' field. A note at the bottom states: 'NOTE: If you manually configure the External Network Number, you should select a Frame Type other than Auto-detect; otherwise other NetWare servers may report address conflicts.' An 'Apply' button is visible in the bottom right corner.

- **Frame Type:** If you have a Novell server on your local network, select the same frame type as the server's.
- **Internal Network Number:** This is a unique number to identify the server on a network. The system will set it to the IP address if Auto-configure option is selected. Or you may enter a unique internal network number manually.
- **External Network Number:** This number identifies a logical network segment on a network. The system can configure it automatically, or you can set the external network number manually.

6. Web Service

To access files on Disk On-line Server via web browser, enable Web File Manager. If Disk On-line server is connected to the Internet and uses a valid IP address, you can access files on the server by web browser from anywhere.

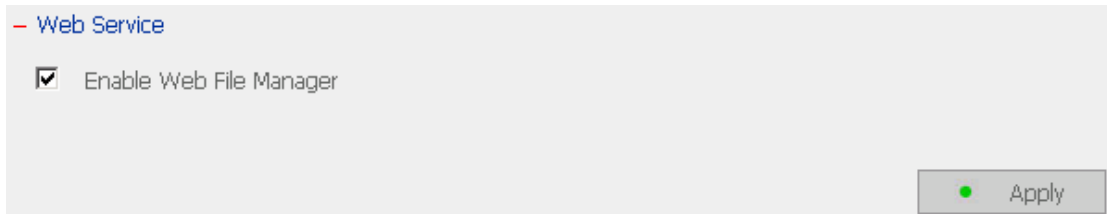

The screenshot shows a configuration panel titled "Web Service" with a minus sign icon. It contains a single checked checkbox labeled "Enable Web File Manager". In the bottom right corner, there is a button with a green dot icon and the text "Apply".

7. FTP Service

To download files from or upload files to Disk On-line Server by using file transfer protocol (FTP), activate FTP service.

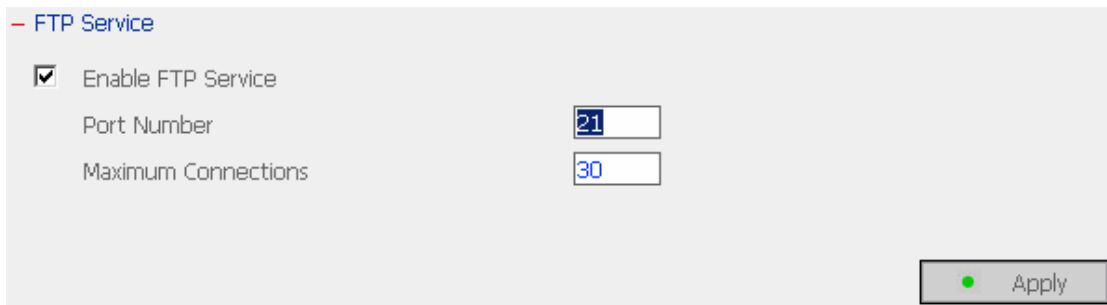

The screenshot shows a configuration panel titled "FTP Service" with a minus sign icon. It contains a checked checkbox labeled "Enable FTP Service". Below this, there are two input fields: "Port Number" with the value "21" and "Maximum Connections" with the value "30". In the bottom right corner, there is a button with a green dot icon and the text "Apply".

8. View Network Settings

You can view current network settings and status in this section.

- View Network Settings

Network	Network File Services
LAN Configuration	
Connection Type	DHCP
IP Address	172.17.20.7
Subnet Mask	255.255.255.0
Default Gateway	172.17.20.1
MAC Address	00:EO:4C:39:00:08
Connection Status	Ready
DHCP Service	
Enabled	No
Address Range	192.168.0.100 - 192.168.0.200
Lease Time	1 Day(s) 0 Hour(s)

- Close

- View Network Settings

Network	Network File Services
Microsoft Networking	
Enabled	Yes
Server Type	Standalone Server
Workgroup	QATEST
WINS server Enabled	No
Apple Networking	
Enabled	Yes
Apple Zone Name	*
Unix/Linux NFS	
Enabled	Yes
Web File Manager	
Enabled	Yes
FTP Service	
Enabled	Yes
Port Number	21
Max Connections	30
NetWare Service	
Enabled	No

- Close

3.6 Disk Configuration

Your Disk On-line Server can accommodate two disks at maximum. You can set the disk volume to the following configurations:

1. Single Disk Volume

You can select to use a standalone disk. In case of disk crash, all data will be lost.

2. RAID 1 Mirroring Disk Volume

Mirroring Disk protects your data by automatically backing up the contents of one disk onto the second disk of a mirrored pair. This protects your data if one of the disks fails. However, the storing capacity is equal to a single disk, as the second disk is used to automatically back up the first one. Mirroring disk volume is suitable for personal or corporate use to store important data.

3. RAID 0 Striping Disk Volume

Striping disk combines two or more disks into one larger disk. It offers the fastest disk access but it does not have any protection of your data if the striped array fails. The disk capacity equals the number of disks in the array times the size of the smallest disk. Striping disk is usually used to maximize your disk capacity or for fast disk access but not for storing important data.

4. Linear Disk Volume

You can combine two or more disks into one larger disk. During file saving, the file will be saved on physical disks sequentially but does not have a disk failure file protection function. The overall capacity of linear disk is the sum of all disks. Linear disk is generally used for storing large data and is not appropriate to use for file protection of sensitive data.

By factory default, Disk On-line Server is preset to one large RAID 0 disk (applicable for servers with two or more disk volumes). To use other disk configurations, the settings can be changed during the first Quick Configuration access.

You can also administer your disk volume in the following ways:

i. Create Disk Volume



ii. Delete Disk Volume

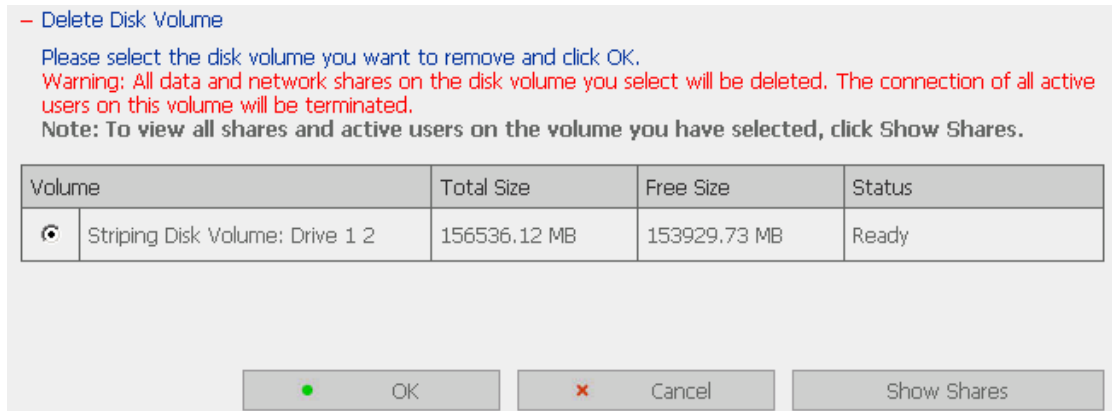

iii. Examine Disk Volume

– Examine Disk Volume



Please select the disk volume you want to examine and click OK. You can check the Fix errors option to resolve errors automatically.

Warning: All active users on this disk volume will be terminated.

Note: To view all shares and active users on the volume you have selected, click Show Shares.

Volume	Total Size	Free Size	Status
 Striping Disk Volume: Drive 1 2	156536.12 MB	153929.73 MB	Ready

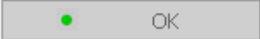
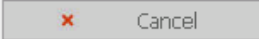
[Fix errors](#)

 OK  Cancel  Show Shares

✓ Disk Volume Operation Report

This page shows the current status and information of disk volume operation.

– Disk Volume Operation Report

Operation Type	Format Disk Volume
Source Disk Volume	Mirroring Disk Volume: Drive 1 2
Target Disk Volume	--
Snapshot Settings	Disabled
Status	Formatting...
Result	--
Comment	This operation may take several minutes to hours, depending on the disk capacity.

Note: This page will automatically refresh every 5 seconds. Click Close to exit this page. You can choose to view the operation result later on the View Disk & Volume Status page.

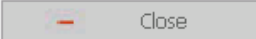
 Close

iv. Format Disk Volume

- Format Disk Volume

Please select the disk volume you want to format and click OK.

Warning: All data and network shares on the disk volume you select will be deleted. The connection of all active users on this volume will be terminated.

Note: To view all shares and active users on the volume you have selected, click Show Shares.

Volume	Total Size	Free Size	Status
 Striping Disk Volume: Drive 1 2	156536.12 MB	153929.73 MB	Ready

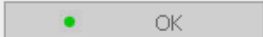
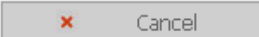
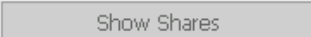
v. View Disk & Volume Status

- Physical Disks			
Disk	Model	Capacity	Status
Drive 1	IC35L080AVVA07-0	78533.44MB	Ready
Drive 2	IC35L080AVVA07-0	78533.44MB	Ready

- Logical Volumes			
Volume	Total Size	Free Size	Status
Striping Disk Volume: Drive 1 2	156536.12 MB	153929.73 MB	Ready

3.7 User Management

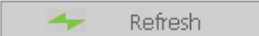
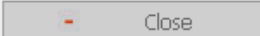
The files on Disk On-line Server can be shared among multiple users. For easier management and better control of users' access right, you have to organize users, user groups and their access right control.

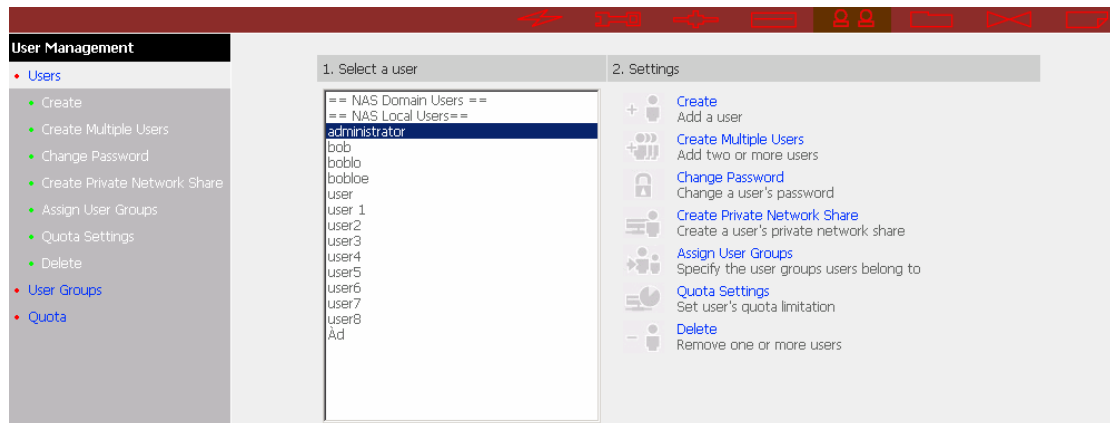

- **Users**

The system has created the following users by default:

Administrator

By default, administrator is a member of the administrator group and has access to system administration. You cannot delete administrator.

Guest

When you use a non-registered user name to login, the server will recognize the user as a Guest and will allow limited access. A guest does not belong to any user group. You cannot delete the user Guest or create a password.

Anonymous

When you connect to the server by FTP service, you can use the name to login as a guest. You cannot delete this user or change its password.

You can create a new user according to your needs. The following information is required to create a new user:

✓ **User name**

The user name must not exceed 32 characters. It is case-insensitive and can contain double-byte characters, such as Chinese, Japanese, and Korean except:

" / \ [] : ; | = , + * ? < > ` '

✓ **Password**

The password must be 6~16 characters long. Avoid using codes that are easily decipherable.

You can perform the following settings for users:

- i. Create
- ii. Create Multiple Users
- iii. Change Password
- iv. Create Private Network Share
- v. Assign User Groups
- vi. Quota Settings
- vii. Delete

- **User Groups**

User group is a collection of users with the same access right to files or folders. Disk On-line server has created the following user groups by default:

- ✓ **Administrators**

All members of administrators group have the right to perform system management. You cannot delete this group.

- ✓ **Everyone**

All registered users belong to everyone group. You cannot delete this group.

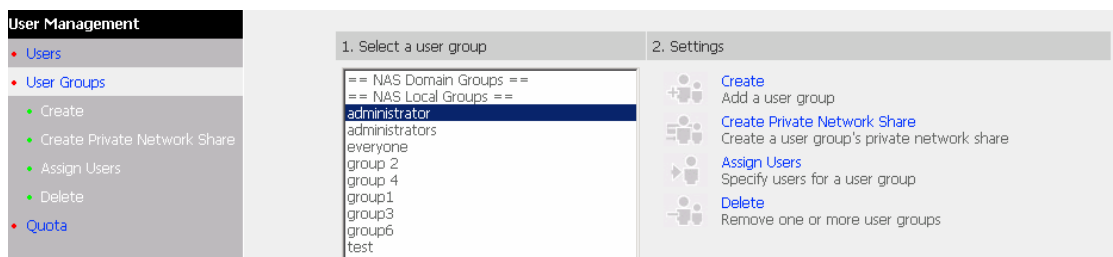

You can manage user groups with the following options:

- Create
- Create Private Network Share
- Assign Users
- Delete

User groups name must not exceed 256 characters. It is case-insensitive and can contain double-byte characters, such as Chinese, Japanese, and Korean, except the following ones:

" / \ [] : ; | = , + * ? < > ` '

To properly manage security, it is very important to manage users and user groups. You may set the share access parameters of each user or user group accordingly.

- **Quota**

To allocate disk volume efficiently, you can specify the quota that can be used by each user. When quota is set, users are not allowed to further use disk space once they have reached their quota limit. By default, no limitations are set for users. You can modify the following two options:

- ✓ Enable quota for all users
- ✓ Quota size on each disk volume

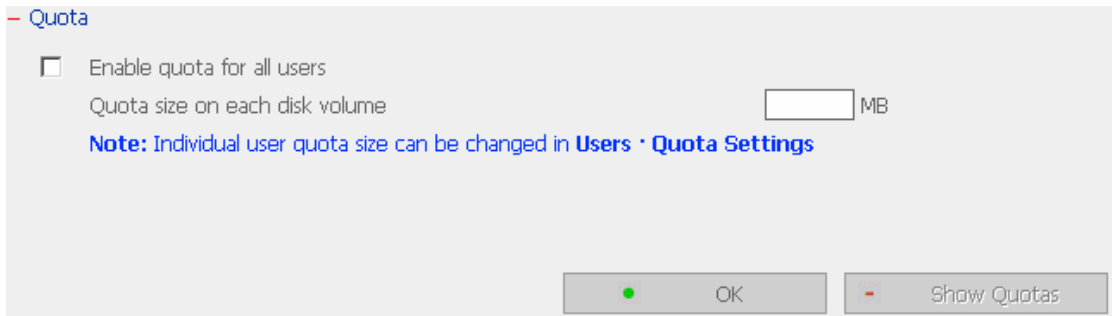

3.8 Network Share Management

The primary purpose of network storage is file sharing. In a standard operation environment, you can create different network share folders for various types of files, or provide different file access rights to users or user groups. By factory default, a "public" share folder is created, which allows full access from all users or guests.

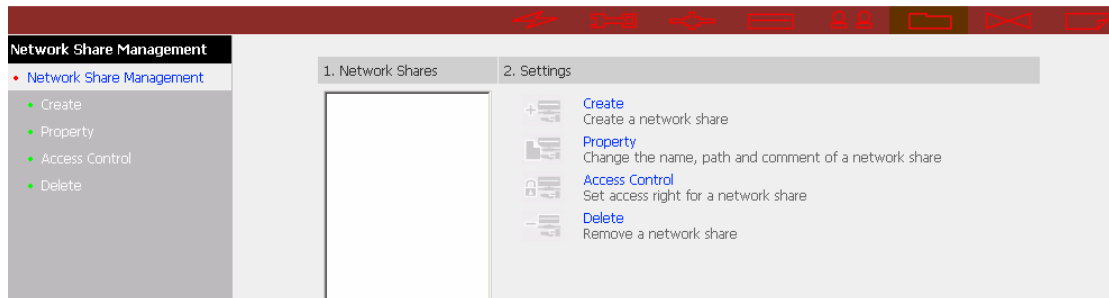

There are four options in Network Share Management:

- i. Create a network share
- ii. Change the name, path and comment of a network share
- iii. Set access right for a network share
- iv. Remove a network share

- **Create**

To create a network share, enter the following information:

- ✓ Network share name

The share name must not exceed 12 characters and cannot contain the following characters:

" . + = / \ : | * ? < > ; [] %

- ✓ Disk volume

This area shows the disk volume status.

- ✓ Path

All data are stored under the assigned path onto the disk volume. You can select "Specify path automatically" to allow the server to automatically create a new path on the disk volume to store the network share files. Or you can assign a specific path for the share folder. The path cannot exceed 256 characters and cannot contain the characters below:

- ✓ Comment

Enter a brief description for the share folder. The comment cannot exceed 128 characters.

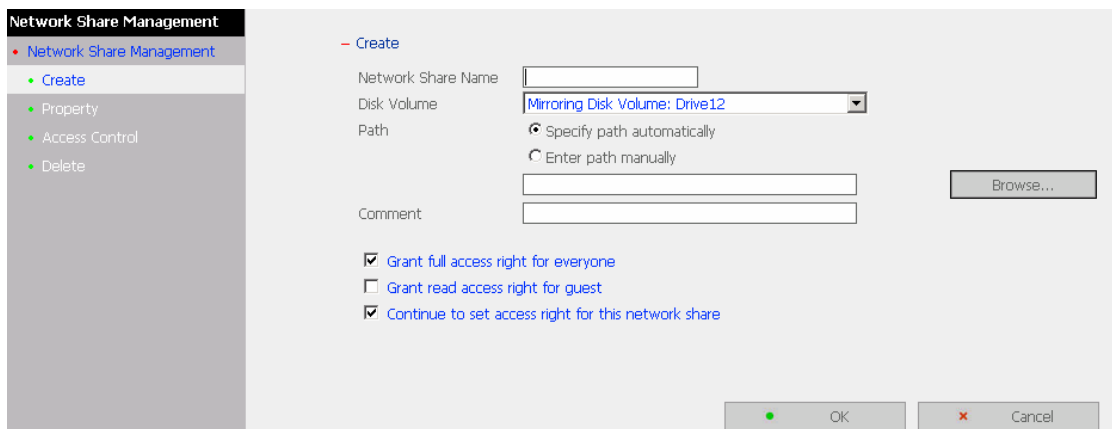

- **Access Control**

Once the network share is created, you can assign access rights to users or user groups:

- ✓ Deny access
Access to the network share will be denied when this option is selected.
- ✓ Read only
Users can read the files only on the network share when read only is assigned.
- ✓ Full access
Users with full access are allowed to read, write, create, or delete files and folders on the network share.

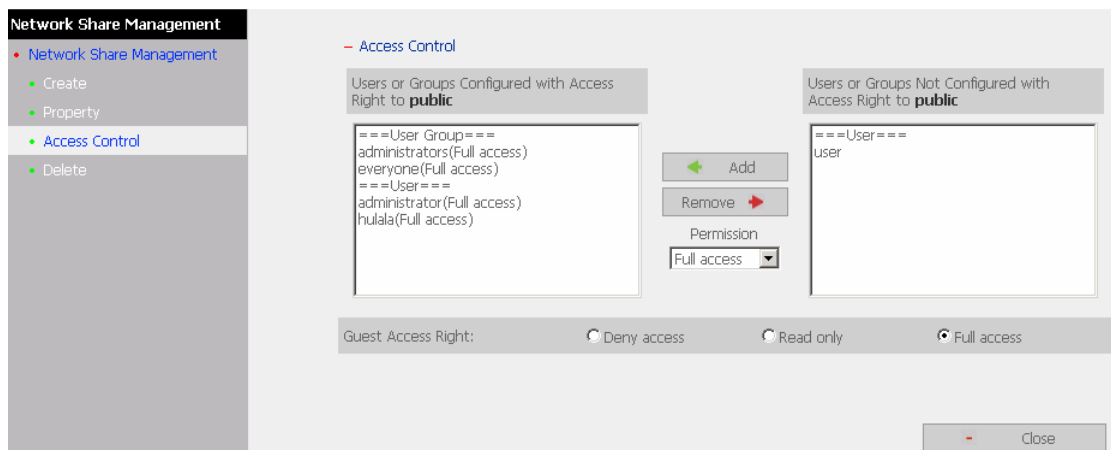

- **Property and Delete**

To edit the property of an existing network share, select a share and click **Property**. You can then edit the content of that share.

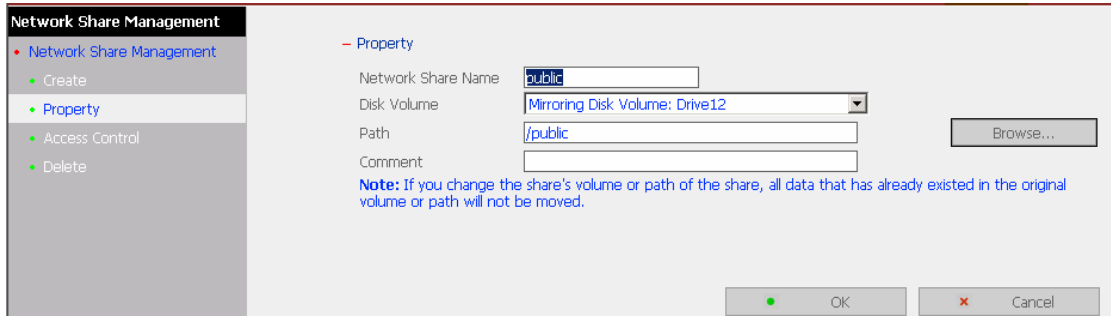

You can also select to delete an existing network share. Click OK to confirm the deletion or Cancel to abort.

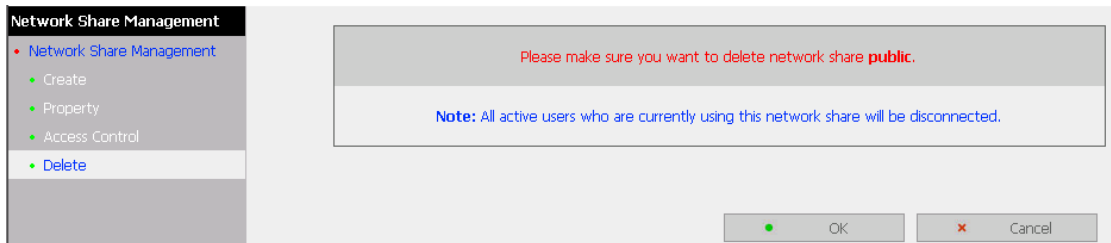

3.9 System Tools

System Tools enable you to optimize the maintenance and management of Disk On-line Server.

3.9.1 SNMP Settings

Enable SNMP (Simple Network Management Protocol) service and complete all necessary settings to manage network components of the server by SNMP. When enabling SNMP Trap Notification, a message will be sent to a specified trap host when an error occurs.

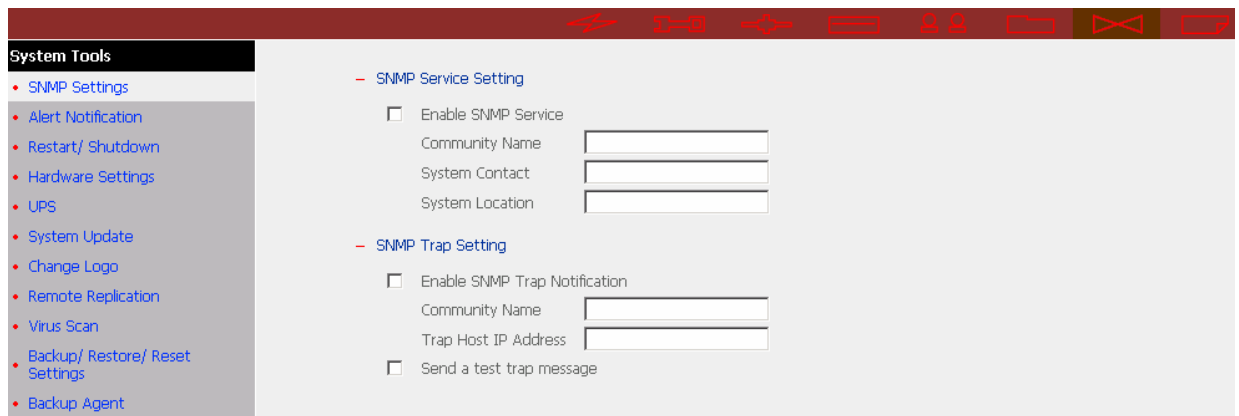

The screenshot displays the 'System Tools' configuration window. On the left is a sidebar menu with the following items: SNMP Settings (selected), Alert Notification, Restart/ Shutdown, Hardware Settings, UPS, System Update, Change Logo, Remote Replication, Virus Scan, Backup/ Restore/ Reset Settings, and Backup Agent. The main content area is titled 'System Tools' and contains two sections:

- SNMP Service Setting**
 - Enable SNMP Service
 - Community Name:
 - System Contact:
 - System Location:
- SNMP Trap Setting**
 - Enable SNMP Trap Notification
 - Community Name:
 - Trap Host IP Address:
 - Send a test trap message

3.9.2 Alert Notification

Enter the e-mail address of administrator and SMTP server IP address. In case of warning or malfunction, an email will be sent to the administrator automatically.

Alert Notification

Alert level:

High: Send e-mails on any errors or warning events

Medium: Send e-mails only on critical errors

Low: No alert e-mails will be sent

E-mail (SMTP) server IP address: . . .

E-mail address 1:

E-mail address 2:

Send a test e-mail

3.9.3 Restart/ Shutdown

Select to restart or shut down Disk On-line Server.

Restart / Shutdown

To restart the server, click Restart.

To shut down the server, click Shut Down.

3.9.4 Hardware Settings

You can enable or disable the hardware functions of Disk On-line Server.

- i. Enable LCD panel setting function
To enable users to configure TCP/IP settings via the LCD panel.
- ii. Enable configuration reset switch
By enabling this option, you can press the reset button for a few seconds to reset the administrator password and system settings to default.
- iii. Enable hard disk standby mode
Set the minutes when there is no access to the server and the hard disk will go to standby mode.
- iv. Enable buzzer
When buzzer is enabled, an alert sound will be played in case of system error.

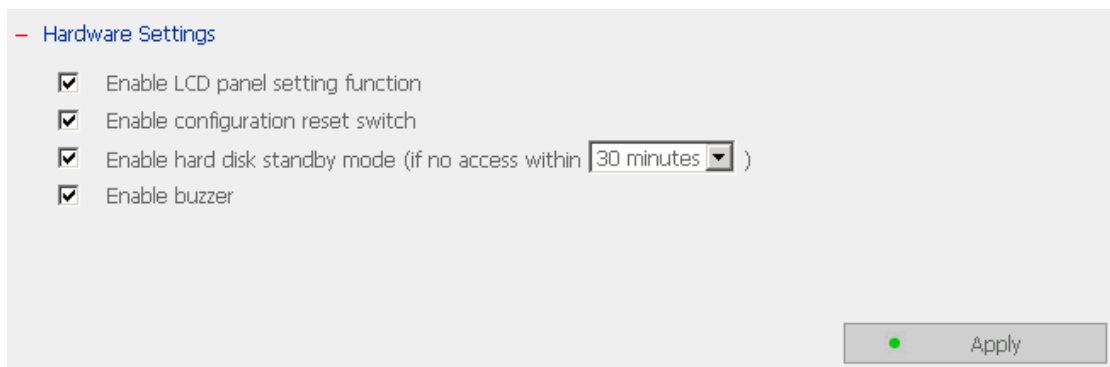

3.9.5 UPS

If your UPS device provides USB interface, you can enable UPS (uninterruptible power supply) support to protect your system from abnormal system shutdown caused by power outage. In case of utility power failure, the system will shut down automatically by probing the power status of the connected UPS unit.

✓ **Enable UPS support**

To activate the UPS support, you can select this option. You can set the shutdown timer to turn off the system automatically after the system detects the AC power is abnormal. In general, the UPS can keep supplying the power for the system for about 5 to 10 minutes. But this depends on the maximum load of the UPS and the number of the loads connected to it.

UPS Model

Select the UPS model from the list. If the UPS model you are using is not available on the list, please contact our technical support.

UPS IP

If you have selected APC UPS with SNMP for UPS model, enter the IP address of the UPS.

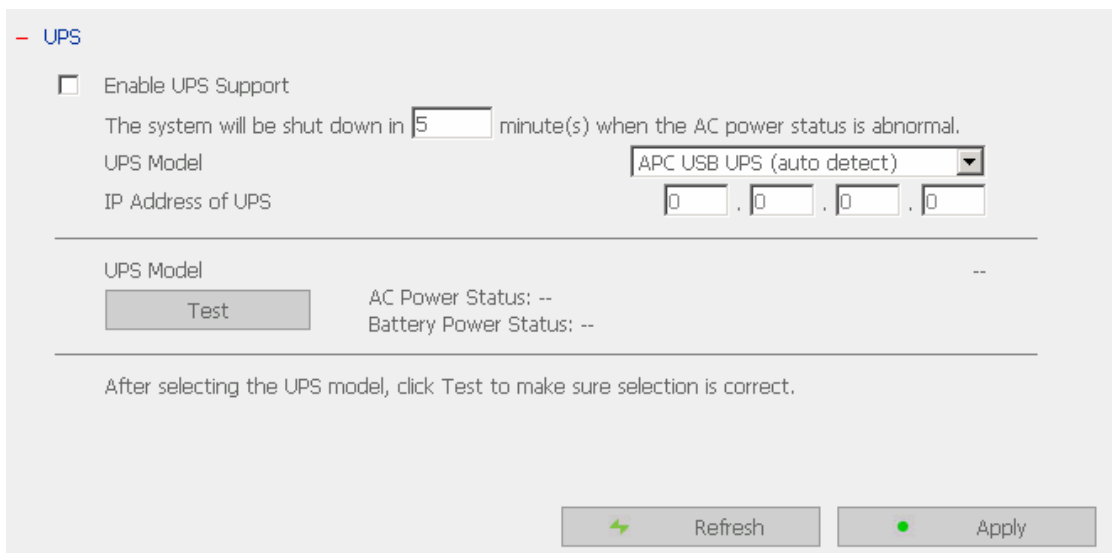

- UPS

Enable UPS Support
The system will be shut down in minute(s) when the AC power status is abnormal.

UPS Model

IP Address of UPS

UPS Model AC Power Status: --
Battery Power Status: --

After selecting the UPS model, click Test to make sure selection is correct.

Note: When UPS support is not enabled, the Test button will not function.

3.9.6 System Update

To update the firmware version of Disk On-line Server, make sure you have obtained the correct version of image file. It is suggested to back up all existing data on Disk On-line Server before updating the image. The current settings will remain unchanged after the system is upgraded.

System Update

To update the system, please obtain a new image. Click Browse to specify the location of the image, then click Update System to proceed with the update.

Current system version: 4.1.4 Build 0120

Note: Make sure you have chosen the correct image file before clicking Update System.

Disk Online Server **NAS-2100**

Network Attached Storage

English Change Password Administration Web File Manager

A reliable and high capacity network attached storage server

- Share your storage over Microsoft, Unix and Apple network.
- Protect your data via RAID technology and management.
- Easy administration through simple web interface.

Version 4.1.4 build 0120

3.9.7 Change Logo

You can choose a personal picture to display on the login page of Disk On-line Server. The size of the picture cannot exceed 20K bytes.

Change Logo

Please select an image from the **To be displayed** pull-down menu. Then click **Apply** to confirm the change.







To upload your own image, click **Browse** to select the image. Then click **Upload** to upload the image.

To replace an image, select an appropriate image from the **To be replaced to** pull-down menu and click **Apply**.

Uploaded image:

To be replaced to:

To be displayed:

 Image 1	 Image 2	 Uploaded Image
 Image 3	 Image 4	 Current Logo Image

Note: For the best image effect, the recommended size for the image is 100 x 100 pixels.

3.9.8 Remote Replication

Remote Replication enables you to replicate local files to remote folders on another server. The files will be compressed before the replication process in order to save time for data transfer.

Using Remote Replication

Login Disk On-line Server, go to Remote Replication in System Tools.

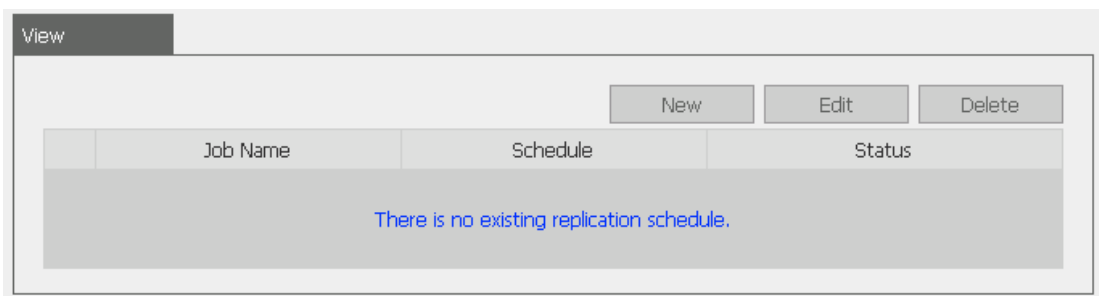

i. New

- a. Click **New** to enter the following page.

Add a remote replication job

Job Name

Remote Destination

Remote Host Name / IP Address

Destination Path (Network Share/Directory) /

User Name

Password

Remote Host Testing (Status: --)

Local Source

Source Path (Network Share/Directory) /

Replicate Now

Replication Schedule Hour : Minute

Daily

Weekly

Monthly Day

Activate file compression

Stop network file services while replicating

Perform incremental replication

Delete extra files on remote destination

- b. Complete all settings and click OK to save or Cancel to quit

Note: To use remote replication, enable Microsoft Networking service, make sure the destination network share and directory have been created, and the user name and password are valid to login the destination folder.

ii. Edit

- Select the job to be edited.
- Click **Edit**.
- Modify the settings.
- Click OK to save or **Cancel** to quit.

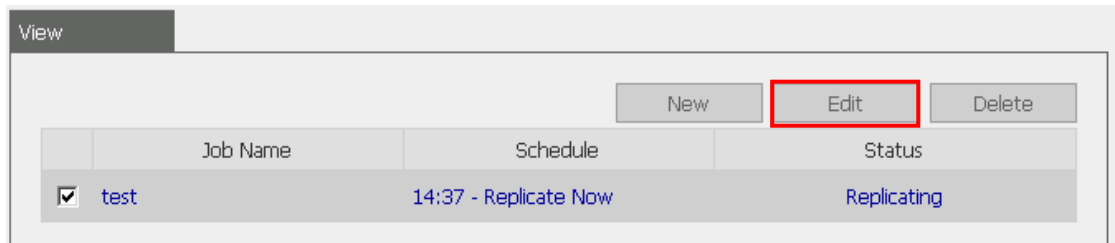

The screenshot shows a window titled "View" with a table of replication jobs. The table has columns for Job Name, Schedule, and Status. The first job is named "test" and is currently "Replicating". Above the table are three buttons: "New", "Edit", and "Delete". The "Edit" button is highlighted with a red rectangular border.

	Job Name	Schedule	Status
<input checked="" type="checkbox"/>	test	14:37 - Replicate Now	Replicating

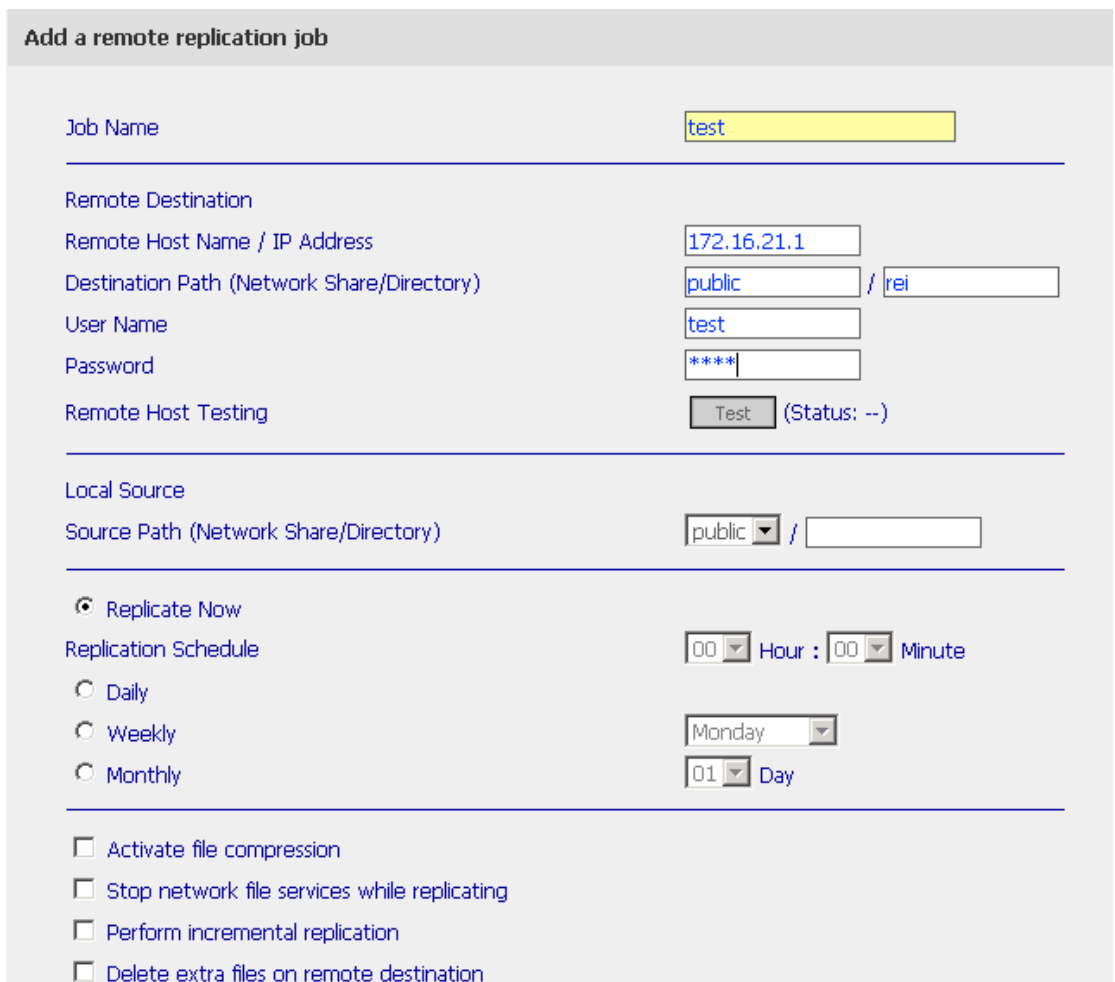

The screenshot shows the "Add a remote replication job" configuration window. It contains several sections for setting up a replication job:

- Job Name:** A text field containing "test".
- Remote Destination:**
 - Remote Host Name / IP Address: 172.16.21.1
 - Destination Path (Network Share/Directory): public / rei
 - User Name: test
 - Password: ****
 - Remote Host Testing: Test (Status: --)
- Local Source:**
 - Source Path (Network Share/Directory): public /
- Replication Schedule:**
 - Replicate Now
 - Daily
 - Weekly: Monday
 - Monthly: 01 Day
- Options:**
 - Activate file compression
 - Stop network file services while replicating
 - Perform incremental replication
 - Delete extra files on remote destination

iii. Delete

- a. Select the job to be deleted.
- b. Click **Delete**.

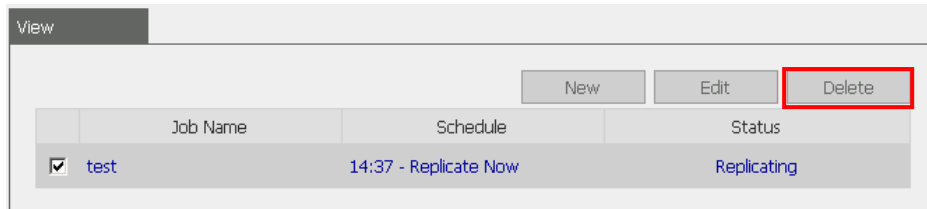

3.9.9 Virus Scan

Virus scanning agent helps protect your system from being infected by viruses. You need to operate Windows NT or Windows 2000 server with virus-scanning software installed to perform real-time virus scanning. To enable virus scan support, specify the IP address of network share, the administrator ID and password.

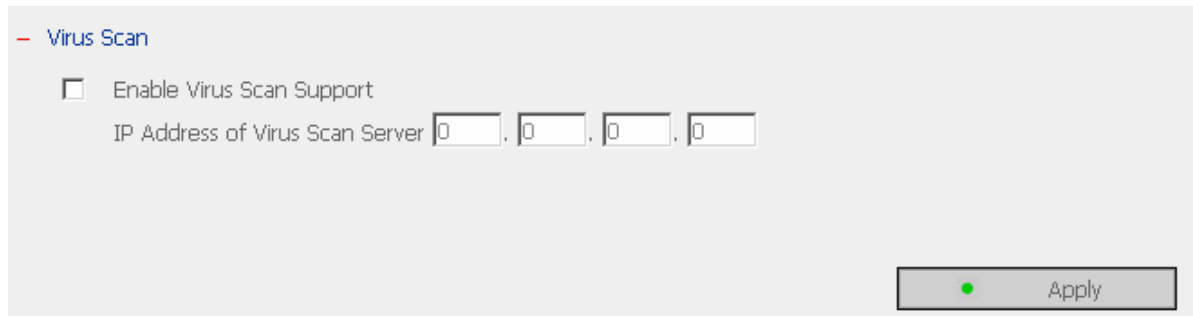

The screenshot shows a configuration window titled "Virus Scan". It contains a checkbox labeled "Enable Virus Scan Support" which is currently unchecked. Below the checkbox is a label "IP Address of Virus Scan Server" followed by four input boxes for the IP address, each containing the digit "0". A green dot is visible to the left of the "Apply" button. The "Apply" button is located in the bottom right corner of the window.

Installing Virus Scan Agent

Make sure virus scan agent and software are installed on the same computer which performs virus scanning before activating the agent.

Follow the steps below to install Virus Scan Agent:

1. Run Install Virus Scan Agent in Disk On-line Server companion CD.
2. Click **Next** to continue Virus Scan Agent Setup.

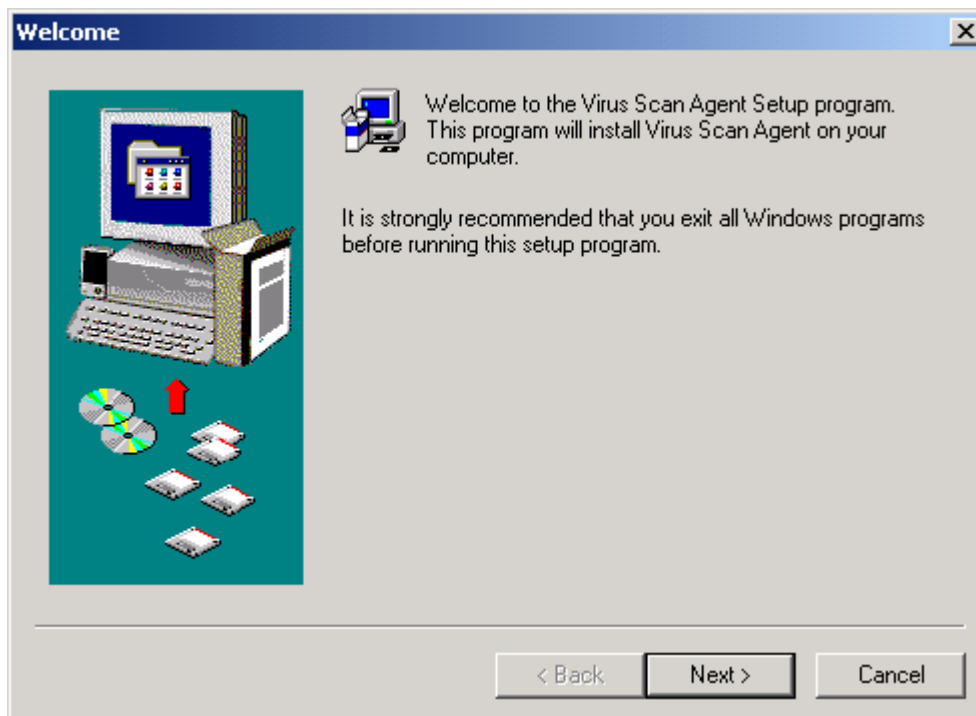

3. Click **Finish** to complete.

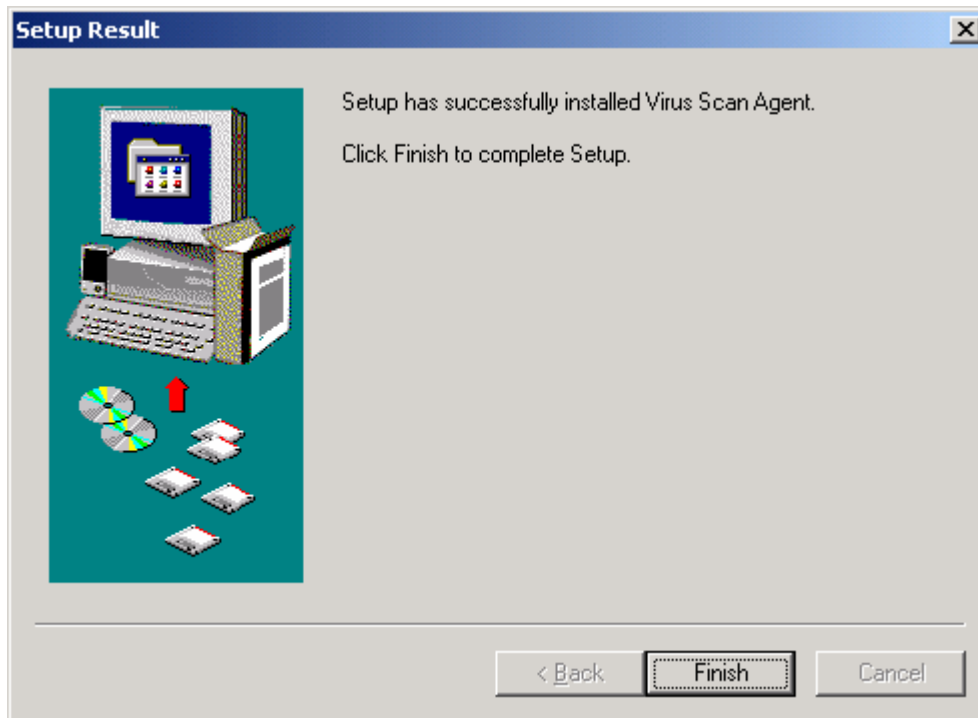

4. A screen will pop up to show the system information the first time you have successfully installed the virus scan agent.

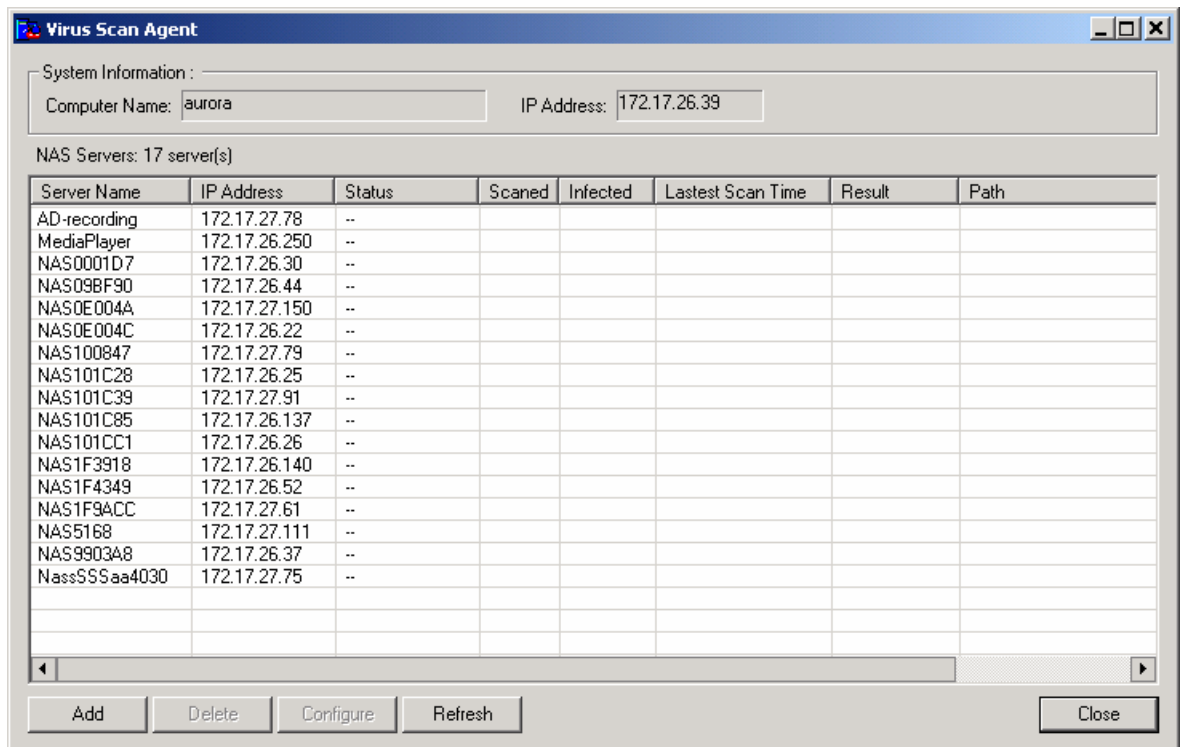

The description of the fields is as below:

Fields	Description
Server Name	Name of the network share under the protection of virus scan agent
IP Address	The IP address of the network share
Status	<p>Connection status of the host network share with the virus scan agent:</p> <ul style="list-style-type: none"> • <i>Disconnect</i>: Not connected to the network • <i>Idle</i>: Connection has been enabled but there is no file transfer for three minutes or more. • <i>Ready</i>: Connection has been enabled and ready to be scanned • <i>--</i>: User name and password have not been set up
Infected	Number of infected files
Last Scan Time	Date and time of the most recent virus scanning job
Result	<p>Scanning result:</p> <p>OK: No files are infected</p> <ul style="list-style-type: none"> • <i>Virus Found</i>: Virus is found. The name of the infected file(s) may not be displayed due to the scanning of other files. Go to administration page to view the name and location of the infected file(s). • <i>Access Denied</i>: Access to the server is denied. <p><i>Authentication Failed</i>: The login user ID is not authorized to access the folder of the network share.</p>
Path	The file location on the network share

Enabling Virus Scan Support

Go to Virus Scan of System Tools. To enable virus scan support, check the box Enable Virus Scan Support. Enter the IP address of the virus scan server and click **Apply**.

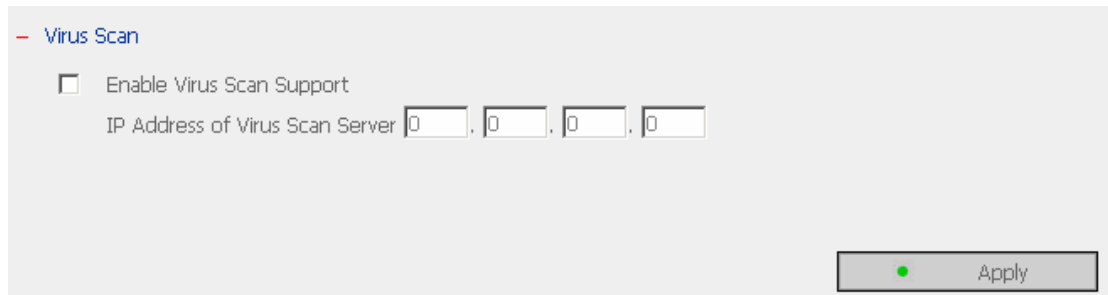

Virus Scan

Enable Virus Scan Support

IP Address of Virus Scan Server . . .

Apply

Viewing Details of Infected Files

To view the details of infected files of the network share, go to Event Logs of Statistics & Logs. A warning message will be shown in the table.

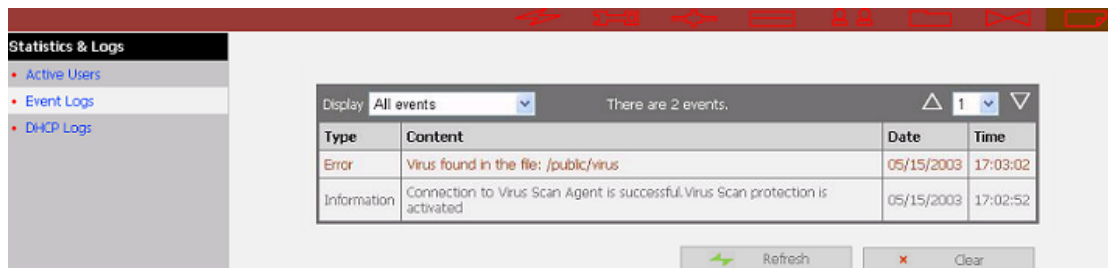

Statistics & Logs

- Active Users
- Event Logs
- DHCP Logs

Display: All events | There are 2 events. | Page 1 of 1

Type	Content	Date	Time
Error	Virus found in the file: /public/virus	05/15/2003	17:03:02
Information	Connection to Virus Scan Agent is successful. Virus Scan protection is activated	05/15/2003	17:02:52

Refresh Clear

3.9.10 Backup/ Restore/ Reset Settings

To backup the setting(s), select the appropriate option(s) and click **Backup**. To restore a backup settings file, click **Browse** to select the file and click **Restore**. To reset the setting(s) to factory default(s), select the appropriate option and click **Reset**.

- Backup/Restore/Reset Settings

- To restore a backup settings file, click Browse to choose the backup settings file. Then click Restore.
- To back up the setting(s), select the appropriate option(s) and click Backup.
- To reset the setting(s) to factory default(s), select the appropriate option and click Reset.

User / User Group Settings
 Disk Configuration
 Share Volume Settings
 Hardware Settings
 System Settings
 Network Configuration
 All Settings

3.9.11 Backup Agent

Backup agent enables Disk On-line Server to support particular backup programs. In addition to being compatible with more tape drives and tape library, backup agent also supports backup and restoration among multiple servers on different OS.

- Backup Agent

To install Backup Agent, click '**Browse...**' to specify the location of the image file. Then, click '**Install Agent**' to install it. To remove Backup Agent, click '**Remove**'.

<input type="text"/>	<input type="button" value="Browse..."/>	<input type="button" value="Install Agent"/>
Installed Backup Agent : Not installed		<input type="button" value="Remove Agent"/>

Enable Backup Agent

Password of Backup Agent :

Status : Not installed

Installation of Backup Agent

Follow the steps below to install Backup Agent:

1. Download Backup Agent program to local disk
 - a. Install Back Agent.
Contact technical support for information of backup agent program.
2. Install Backup Agent
 - a. Enter Disk On-line Server administration page. Go to System Tools and select Backup Agent.
 - b. Click **Browse** to select Backup Agent program.
 - c. Click **Install Agent**. When the installation is completed, the name of backup agent will be displayed, e.g. NetVault 6.5.3:

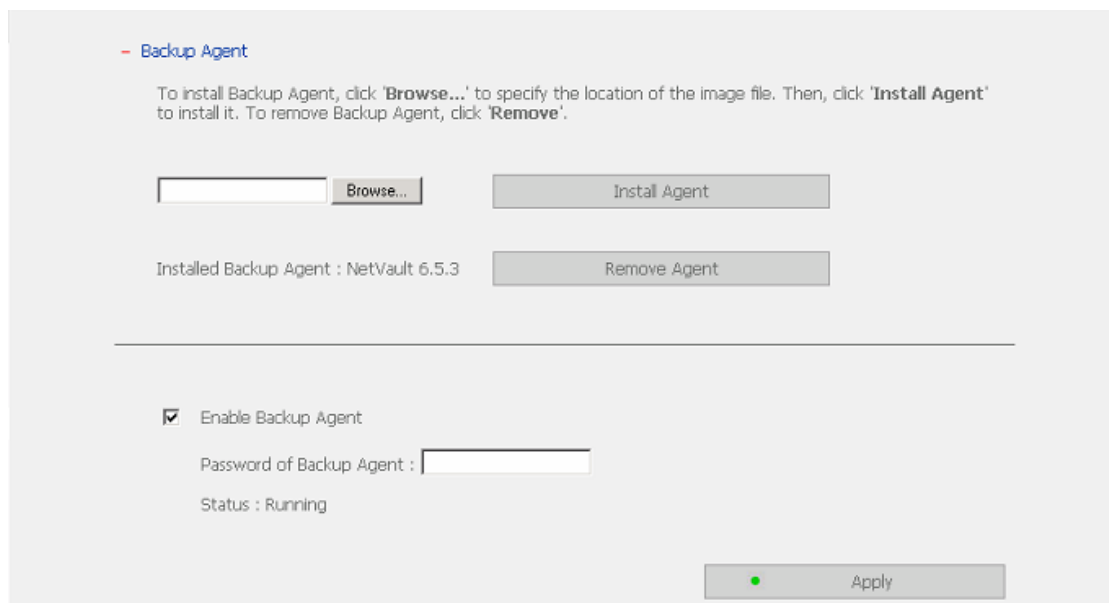

The screenshot shows a web-based interface for managing the Backup Agent. At the top, there is a section titled "Backup Agent" with a minus sign icon. Below the title, there is instructional text: "To install Backup Agent, click 'Browse...' to specify the location of the image file. Then, click 'Install Agent' to install it. To remove Backup Agent, click 'Remove'." Below this text, there is a text input field followed by a "Browse..." button and an "Install Agent" button. Below the input field, it says "Installed Backup Agent : NetVault 6.5.3" and there is a "Remove Agent" button. A horizontal line separates this section from the next. Below the line, there is a checkbox labeled "Enable Backup Agent" which is checked. Below the checkbox, there is a text input field for "Password of Backup Agent :". Below the password field, it says "Status : Running". At the bottom right, there is an "Apply" button with a green dot icon.

3. Configure and enable Backup Agent
 - a. Click **Enable Backup Agent**.
 - b. Enter the password for Backup Agent.
 - c. Click **Apply**. The status will be shown as Running.

- Backup Agent

To install Backup Agent, click 'Browse...' to specify the location of the image file. Then, click 'Install Agent' to install it. To remove Backup Agent, click 'Remove'.

Installed Backup Agent : NetVault 6.5.3

Enable Backup Agent

Password of Backup Agent :

Status : Running

3.10 Statistics & Logs

You can view the event logs of all currently online users on Disk On-line Server for system monitoring.

- **Active Users**

This page shows all users that are currently logged on to the system.

- **Event Logs**

Disk On-line Server can store thousands of recent event logs, including warning, error and information messages. In case of system malfunction, the event logs can be retrieved to help analyze the system problem.

- **DHCP Logs**

If DHCP server function is activated, you can use it to monitor all of the assigned dynamic addresses, client MAC addresses and other information.

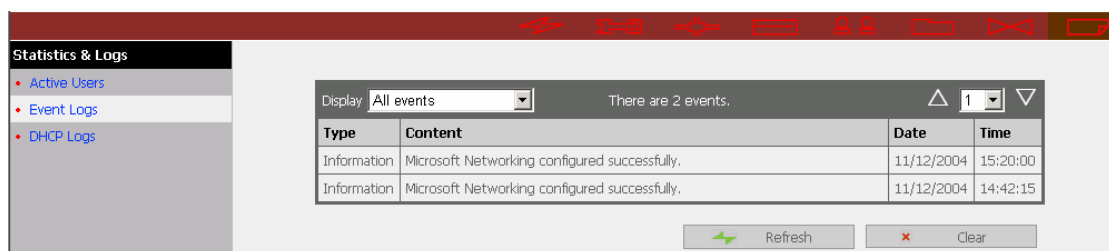

The screenshot shows a web interface for 'Statistics & Logs'. On the left, there is a sidebar with three menu items: 'Active Users', 'Event Logs', and 'DHCP Logs'. The main area displays a table of event logs. At the top of the table, there is a 'Display' dropdown menu set to 'All events' and a status indicator 'There are 2 events.' Below the table, there are two buttons: 'Refresh' and 'Clear'.

Type	Content	Date	Time
Information	Microsoft Networking configured successfully.	11/12/2004	15:20:00
Information	Microsoft Networking configured successfully.	11/12/2004	14:42:15

Chapter 4 Accessing Disk On-line Server

4.1 Using Microsoft Windows

1. You can access Disk On-line Server in Windows OS by the following ways:
 - By Quick Install Wizard. For further information, please refer to Appendix C.
 - You may also search for Disk On-line Server within the Network Neighborhood. Locate the workgroup and find the name of your Disk On-line Server. When the server is found, double-click on the server name to connect.
 - You may also use "Search for Computers" function to look for your Disk On-line Server in Windows. Under Windows ME or Windows 2000, please follow these steps:
 - i. Open "My Network Places".
 - ii. Under the tool bar, click **Search**.
 - iii. Enter the name of Disk On-line Server in Computer Name field.
 - iv. Click **Search**.

When Disk On-line Server is found, double click the item to access the server.

2. Once the connection to Disk On-line Server is successful, all listing on your available network share will be displayed. Select an appropriate network share folder and select **Map Network Drive** by right clicking on the item. To make the share folder available for your next start-up, check the **Reconnect at logon** box on the popup window and click OK to map the folder as your network drive.

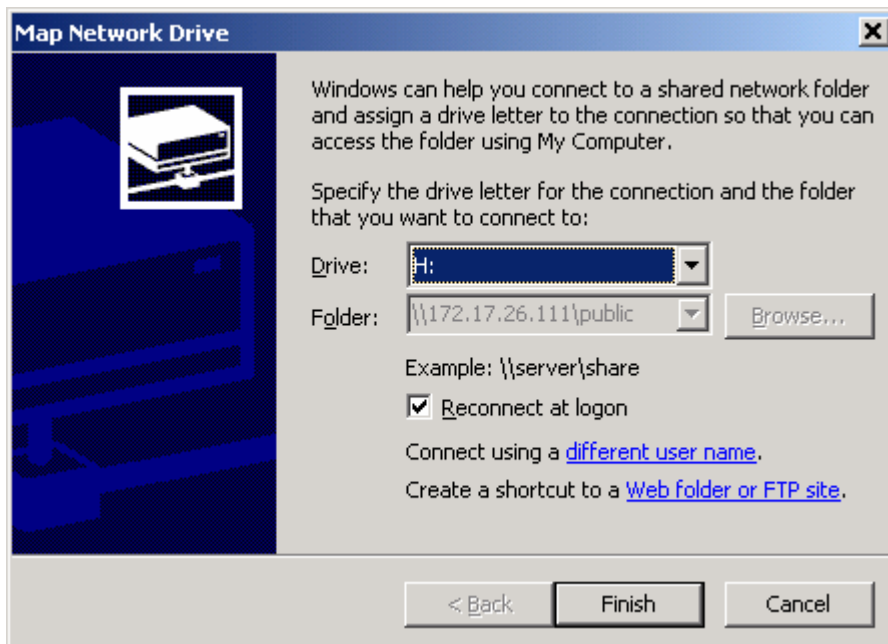
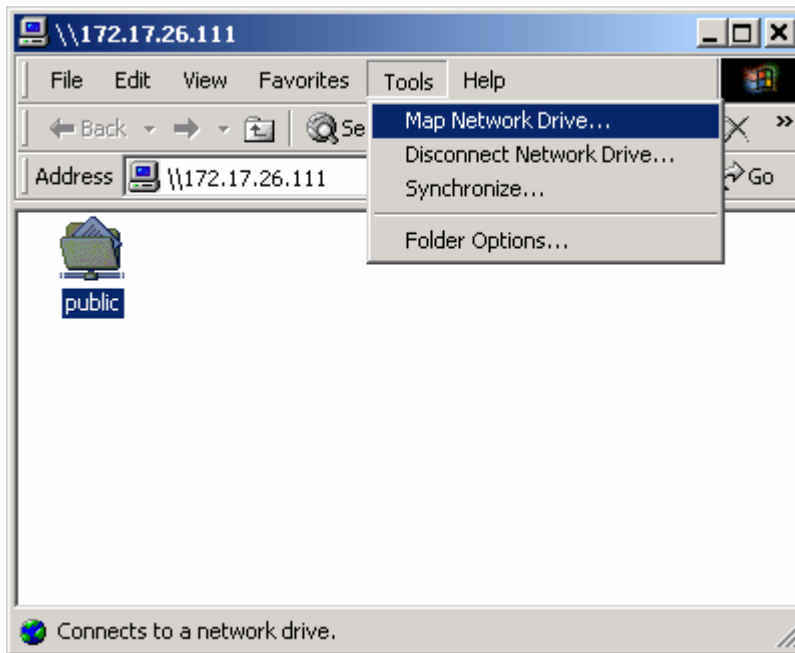

4.2 Using Apple MAC OS

If you are an Apple MAC user, you can access Disk On-line Server by the following ways:

1. Using Network Browser

- a. Choose "Network Browser" in Apple menu.

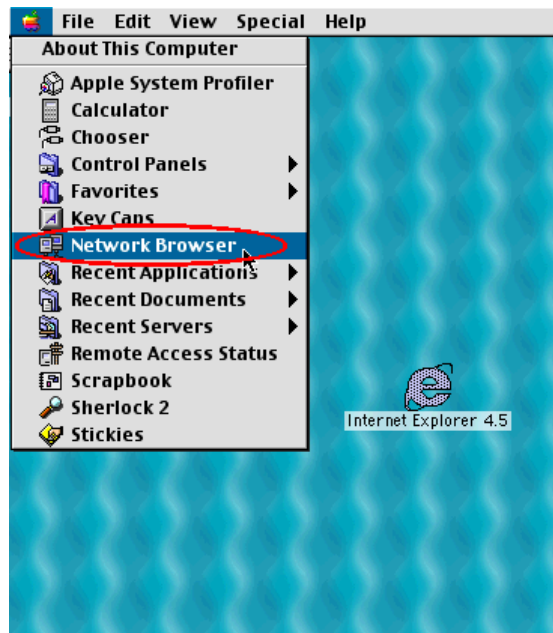

- b. In "Network Browser", choose AppleTalk. A list of computers on the AppleTalk network will appear. Select Disk On-line Server.

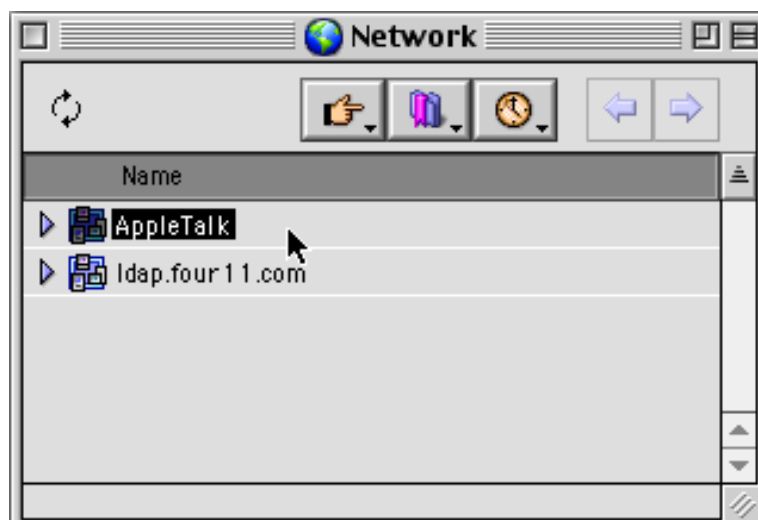

- c. Enter the login name and password, or use "Guest" to enter. Click **Connect**.

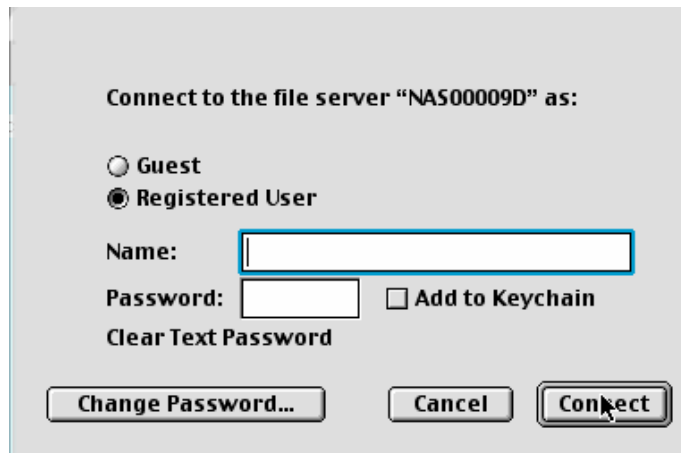

- d. When Disk On-line Server is connected, all network shares will be shown.

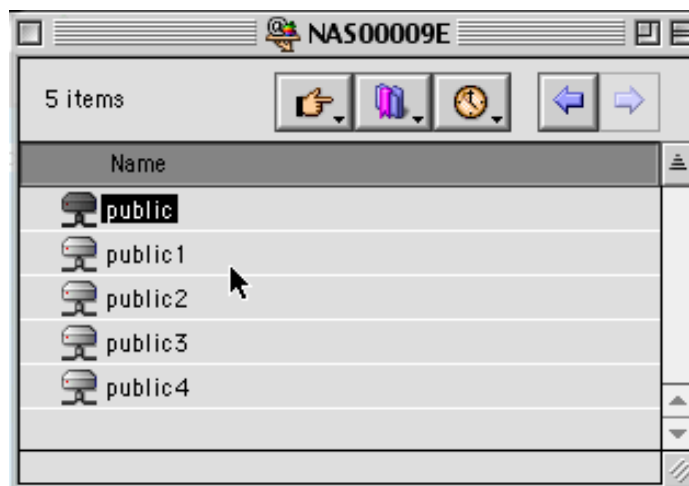

- e. Choose a network share to connect. The network share will appear on the desktop.

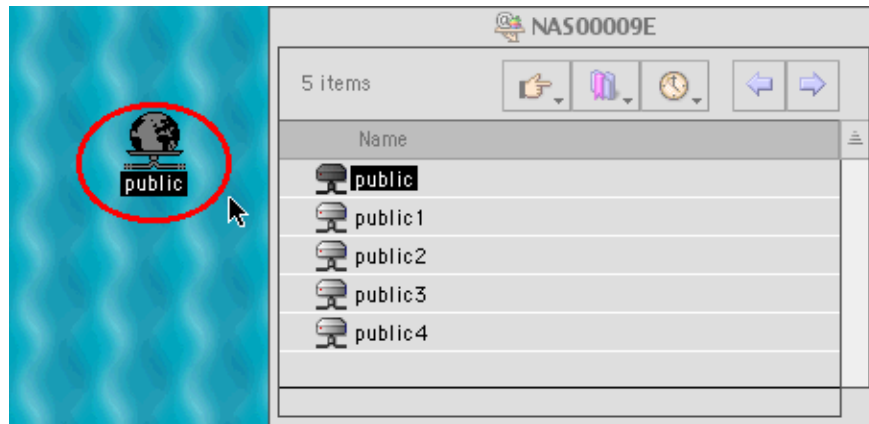

2. Using Chooser

- a. Select **Chooser** on Apple menu bar.

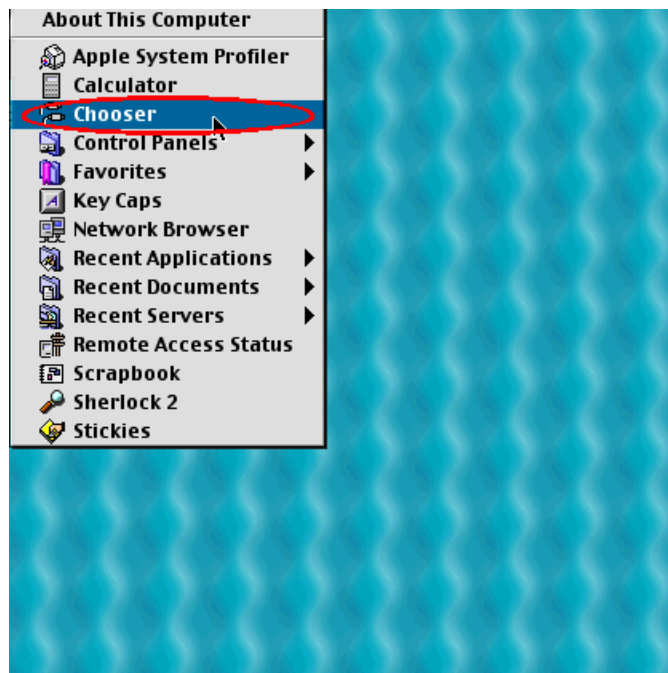

- b. Click on **AppleShare**. The name of Disk On-line Server will appear on the right side of the window.

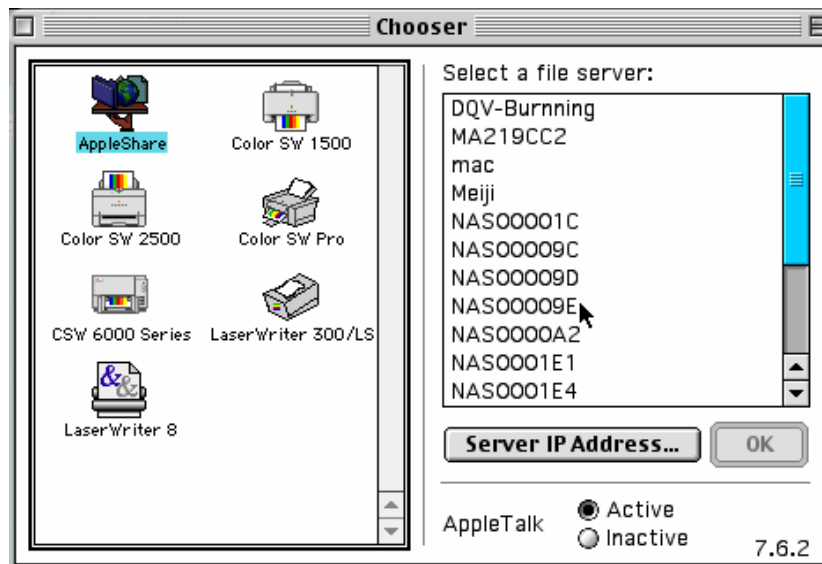

- c. Use the mouse to highlight Disk On-line Server and click OK.

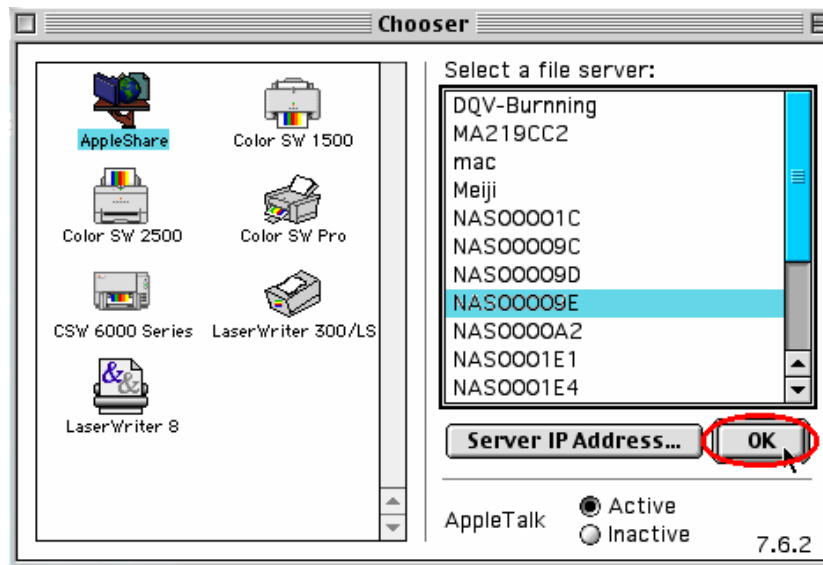

- d. Enter the correct login name and password or use "Guest" to login, and then click **Connect**.

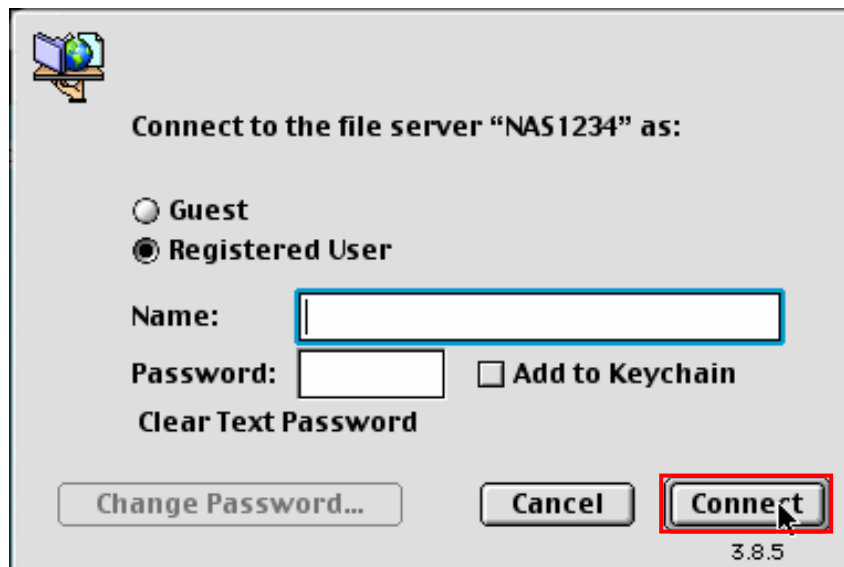

- e. All available network shares will be listed. Select a network share and click OK.

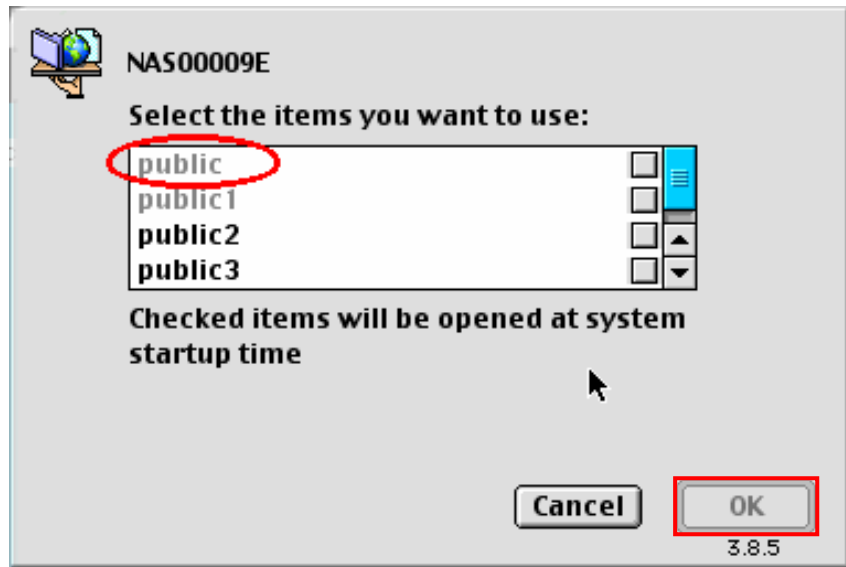

- f. Close the Chooser program. Double click on the icon on the desktop to access the files.

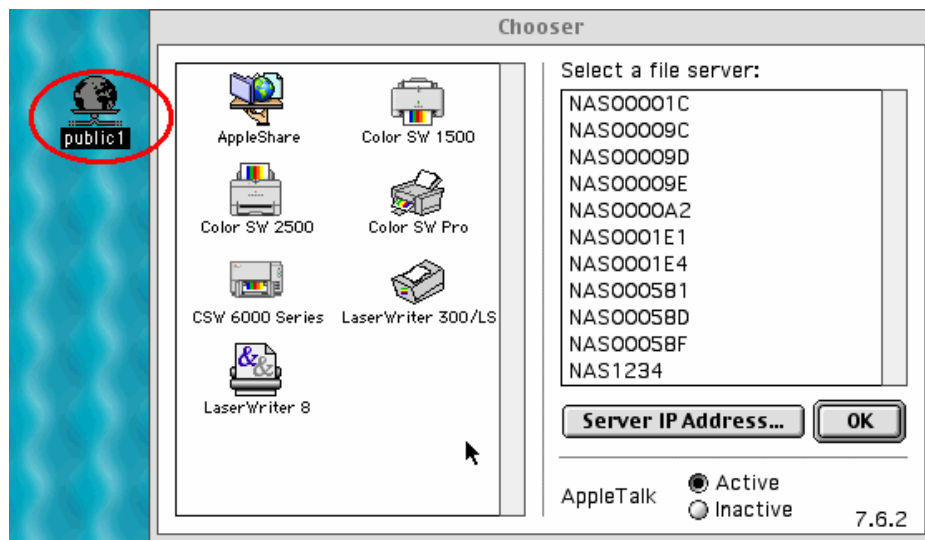

4.3 Using Unix/ Linux OS

In addition to Microsoft and MAC OS, Disk On-line Server also supports Unix-based systems such as IBM AIX, HP-UX, Sun Solaris, Linux, Free BSD, etc. through the NFS service:

Note: Configure NFS settings in User Management page for users who use this feature before proceeding to the steps below.

1. On Unix, run the command:

```
mount -t nfs <Disk On-line Server IP address>:/<Network Share Name>  
<Directory to Mount>
```

For example, if your Disk On-line server's IP address is 192.168.0.1 and you want to link the network share folder "public" under the /mnt/pub directory, use the following command.

```
mount -t nfs 192.168.0.1:/public /mnt/pub
```

Note: You must login as "root" user to initiate the above command.

2. Login as the user id that you define, you can use the mounted directory to access your network share files.

4.4 Netware Service

To use Novell Netware service, enable this option and enter the server name for Netware network. The server will then operate in a manner similar to a Novell NetWare 3.12 file server.

4.5 Using Web Browser

Other than OS support, your Disk On-line Server also provides a convenient web file management interface that allows using a standard web browser to access your data. If you link Disk On-line Server to the Internet and use a public IP address, you can access the files on the server anywhere. For more information, please refer to Appendix B.

4.6 Using File Transfer Protocol (FTP)

In addition to working with multiple operating systems, Disk On-line Server also supports connection via FTP. Enter the correct user name and password to connect the server or access the public share folders as guest.

1. Follow the steps below to use FTP service (based on Windows 2000 as example):



2. Click **FTP**.

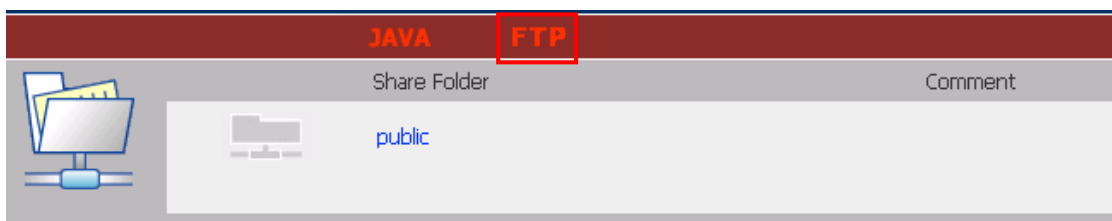

3. Enter user name and password.

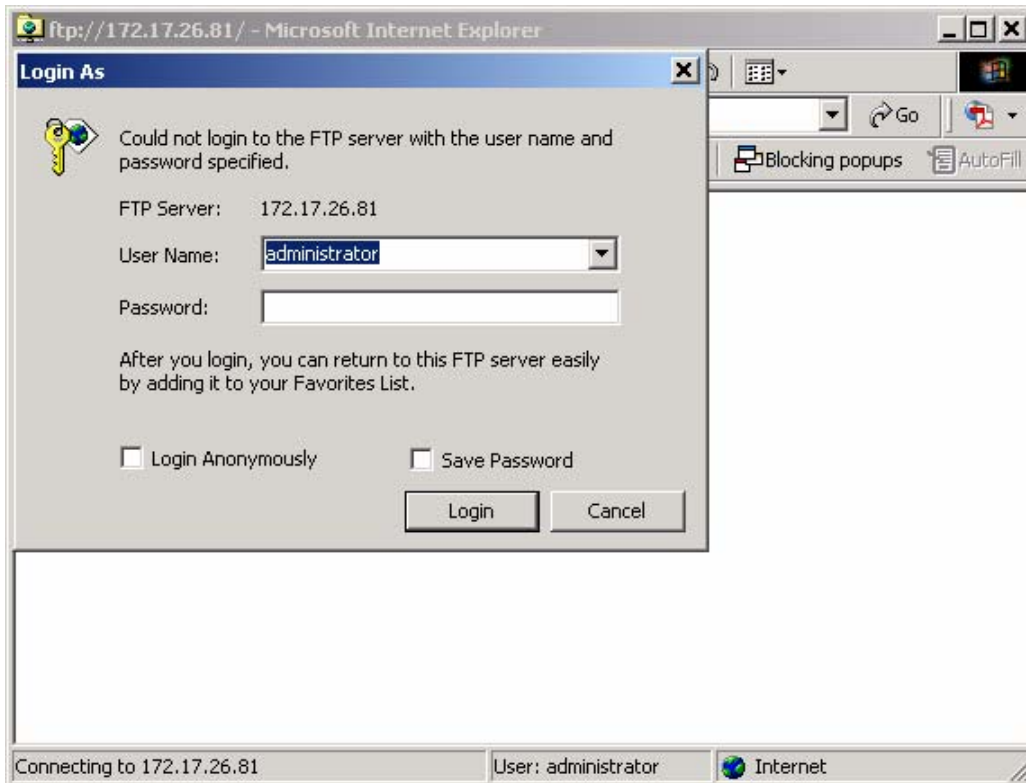

4. The share folder will be shown. You can then manage the folder by dragging and dropping files to it, as well as rename or delete the files.

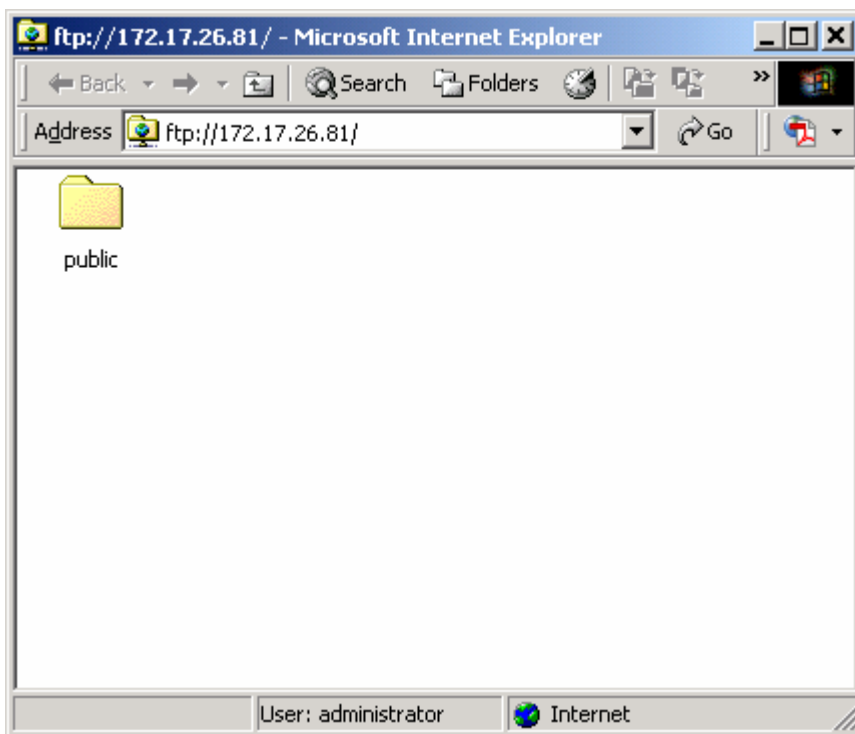

Chapter 5 Disk On-line Server-Maintenance

Disk On-line Server is specially designed to run 24 x 7 and be ready at all times against system crash caused by power outage. This section provides a general overview on system maintenance.

5.1 Restart/ Shut down Server

Follow the steps below to restart or shut down Disk On-line Server.

1. Ask all active users of NAS to save their files and disconnect from the server.
2. Enter the administration page and select Restart/ Shutdown in System Tools.
3. Click **Restart** to reboot the server or **Shut Down** to turn off the server. You can perform these actions by the LCD panel.



5.2 Reset Administrator Password and Network Settings

To reset the administrator password and network settings of Disk On-line Server,

1. Press the reset button of Disk On-line Server for a few seconds. A beep sound will be heard.
2. Login Disk On-line Server with the default user name and password:

User name: **administrator**

Password: **admin**

Note: To reset the system by the reset button, the option "Enable configuration reset switch" in Hardware Settings must be activated.

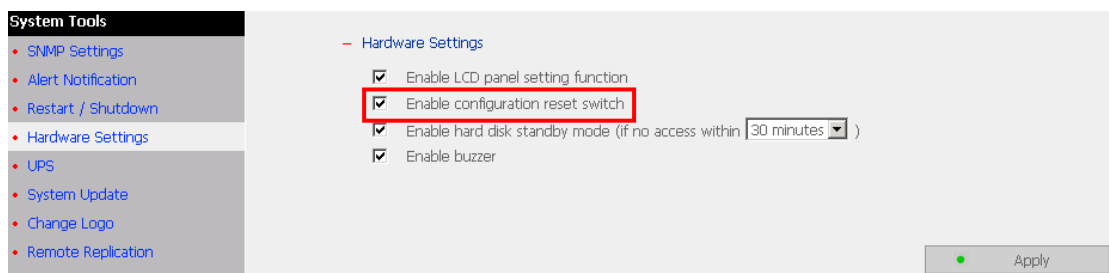

5.3 Disk Failure or Malfunction

When you encounter disk malfunction or failure, please do the following:

1. Record the malfunction status or error messages.
2. Stop using the failed Disk On-line Server and turn off the server.
3. Contact customer service for technical support.

Note: Your Disk On-line Server must be repaired by professional technicians, please do not try to repair the server yourself.

Please back up any important files or folders to avoid potential data loss due to disk crash.

5.4 Power Outage or Abnormal Shutdown

In case of power outage or improper shutdown of Disk On-line Server, the system will resume to the state before it is shut down. If your server does not function properly after restart, please do the following:

1. If the system configuration is lost, configure the system again.
2. In the event of abnormal operation of the server, contact customer service for technical support.

To avoid the above situations, please back up your data periodically and make sure you have done the following:

1. Follow the instructions described in Chapter 5.1 to restart or shut down the server.
2. If there is an anticipated power outage, back up important data and turn off the server properly until power supply is resumed.

Appendix A LCD Panel

Displayed Information

When Disk On-line Server is turned on, the server name and IP address will be shown.

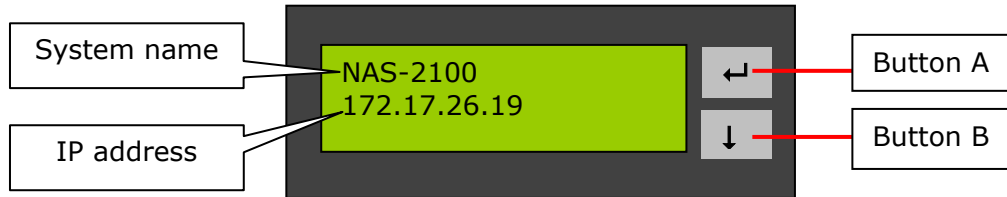

Check disk information and firmware version

1. Press button B to view disk information, i.e. number of disks and disk size.

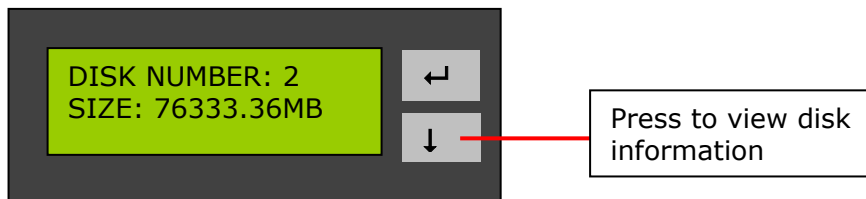

2. Press button B again to view the server model and firmware version.

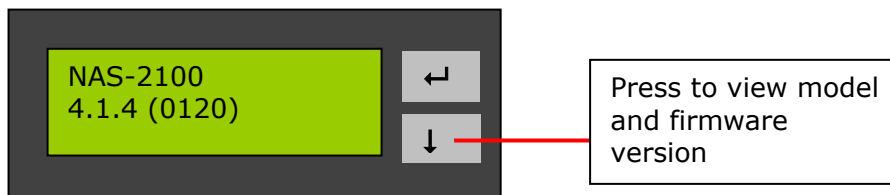

System Setting Function

1. Press button A for two seconds to enter configuration page.

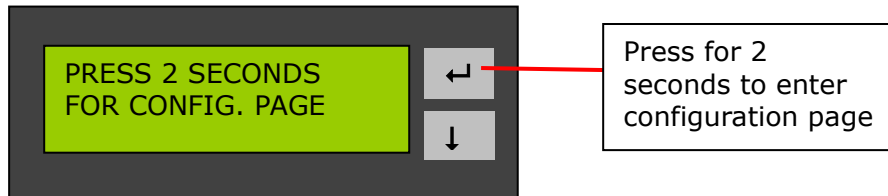

2. Press button B to select an item: NETWORK SETTINGS, POWER DOWN, REBOOT SYSTEM, and EXIT.

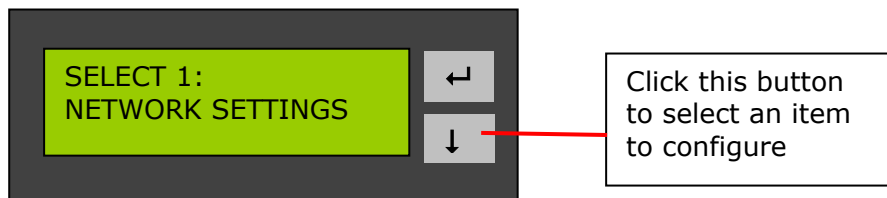

Network Settings

Enter NETWORK SETTINGS configuration page and press button B to select one of the following options. The one marked with * means it is being used for connection.

- DHCP
DHCP will obtain IP address automatically.
- STATIC IP
Press button A to select STATIC IP. Then configure the IP address.
 - i. SET STATIC IP
Press button B to enter 0~255 and press button A to set the next number for the IP address.
 - ii. SET NETMASK
Follow the above procedure to set the netmask address.
 - iii. SET GATEWAY
Follow the above procedure to set the gateway address.
 - iv. SELECT STATIC IP
Press button B to select YES or NO. When YES is selected, you will be asked to restart the system.
- EXIT
To return to the previous menu.

POWER DOWN

Press button B to select POWER DOWN and press button A to confirm shutting down Disk On-line Server.

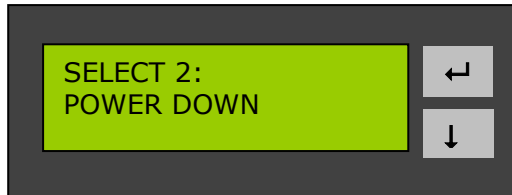

REBOOT SYSTEM

Press button B to select REBOOT SYSTEM and press button A to confirm restarting the system.

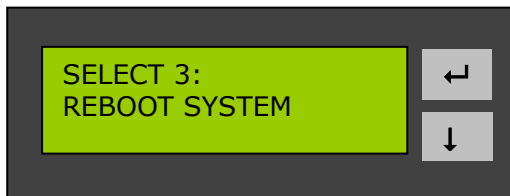

Exit Configuration Page-EXIT

Press button A and select EXIT, then press the button again to confirm exiting the configuration page.

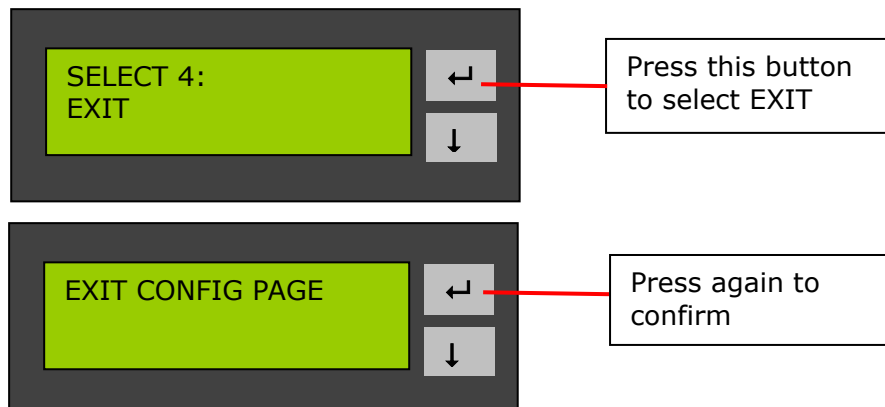

Appendix B Web File Manager

Using Web File Manager

Launch the web browser and go to Disk On-line Server home page. Select **Web File Manager** and enter the correct login name and password. You may also enter "guest" in the login name field with no password to access the network shares on Disk On-line Servers as an anonymous guest.

Note: Make sure a network share has been created before using Web File Manager.



Select an existing network share for management.

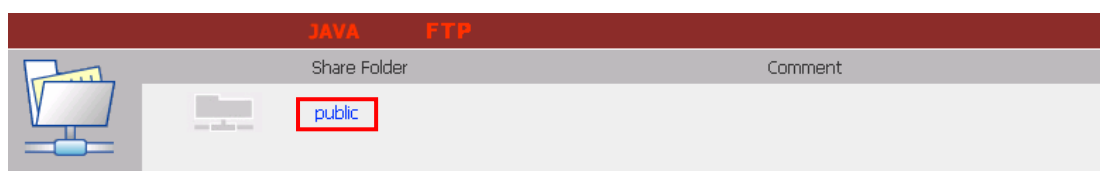

You can organize network share folders of Disk On-line Server. With Web File Manager, you can upload, rename, or delete files and folders in the network shares.

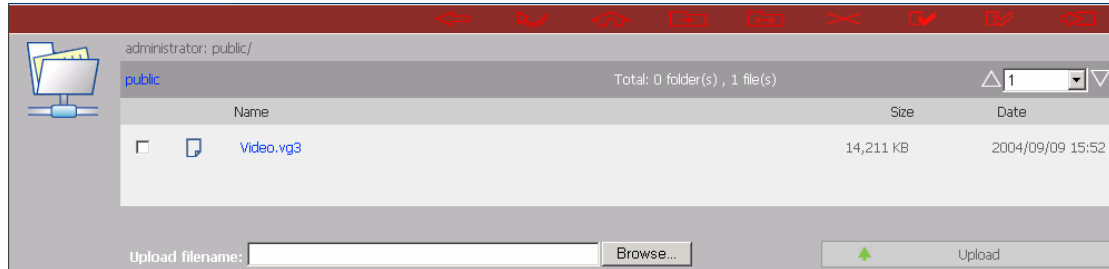

- **View files online**

Click on a file displayed on the web page. The information of the file will be displayed. If your browser does not support the file format, the download window will pop up automatically. Once the file is downloaded, you can open it on your computer.

- **Create folder**

- Select a network share or folder in which you want to create a new folder.
- Click  (Create Folder) on the toolbar.
- Enter the name of the new folder and click OK.

- **Rename file or folder**

- Select a file or folder to rename.
- Click  (Rename) on the toolbar.
- Enter the new file or folder name and click OK.

- **Delete file or folder**

- Select a file or folder to delete.
- Click  (Delete) on the toolbar.
- Confirm to delete the file or folder.

To delete all files and folders, click  (Select All) and then  (Delete).

- **Upload file**
 - i. Open the folder to upload file to.
 - ii. Click **Browse** to select the file.
 - iii. Click **Upload**.

- **Download file**
 - i. Select a file to download.
 - ii. Right click the mouse and select "Save As" to save the file.

- **Logout**

To exit Web File Manager, click  (Logout).

- **Viewing Files Named in Chinese**





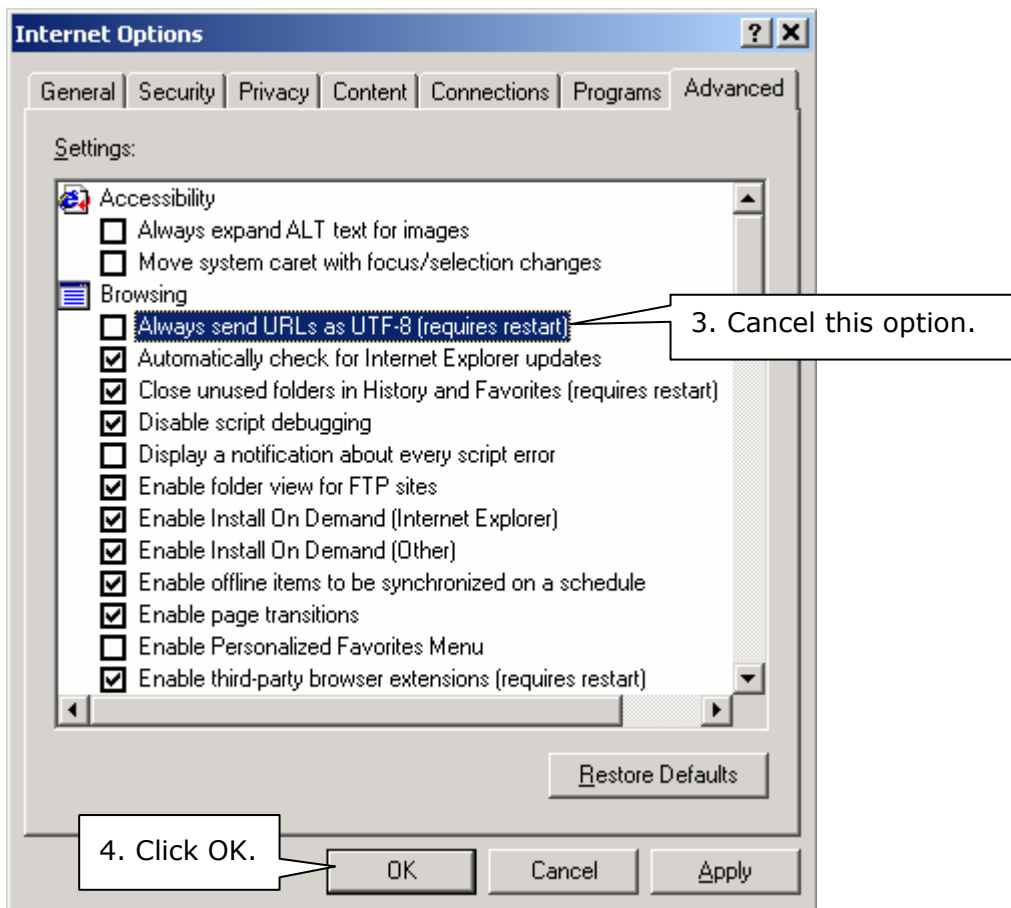
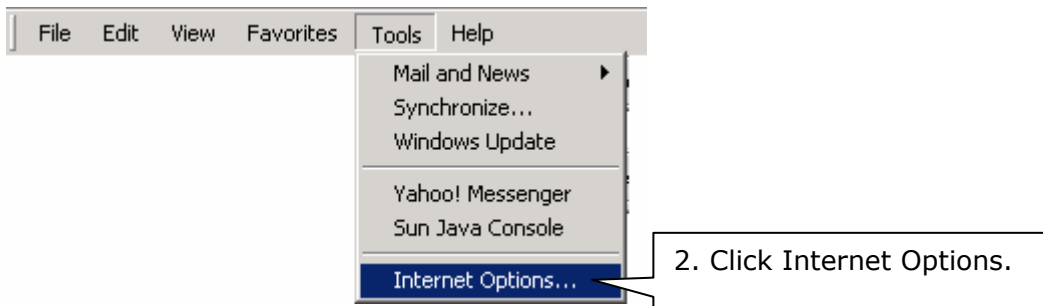







To view files named in Chinese, you may have to configure the browser settings. Take Internet Explorer as an example, follow the steps below to configure the settings.

1. Click on **Tools** in IE browser.



5. Restart the browser.

Web File Manager Icons

Icon	Description
	Up-return to the parent folder
	Refresh-reload the current page
	Home-return to network share list home page
	Create folder
	Rename file or folder
	Delete file or folder
	Select all
	Cancel selection
	Logout
	Full access network share folder
	Read-only network share folder
	Malfunction network share folder

Appendix C Quick Install Wizard

Quick Install Wizard enables you to search for all available Disk On-line Servers within the local network, and view the server name, IP address, and workgroup etc. You can also configure the disk name, date and time, etc. via Quick Install Wizard.

Screenshot

The screenshot shows the Quick Install Wizard application window. The window title is "Quick Install Wizard". The main area displays a table of Disk On-line Servers. The table has four columns: Name, IP Address, Workgroup, and Version. Below the table are several buttons: Configure, Details, Map Drive, Refresh, Help, and Exit. Callout boxes provide descriptions for various elements in the window.

Name	IP Address	Workgroup	Version
MediaPlayer	172.17.26.250	NAS	3.10
NAS09BF90	172.17.26.44	NAS	3.10
NAS0E004A	172.17.27.150	NAS	3.12
NAS9903A8	172.17.27.67	QATEST	4.1254
NAS101C39	172.17.27.91	QATEST	4.1254
NAS100847	172.17.26.78	NAS	4.1254
NAS101C28	172.17.27.96	QATEST	4.1254
NASA99811	172.17.27.113	NAS	4.1254
NAS0E0034	172.17.26.17	NAS	4.1254
NAS0E90D2	172.17.27.93	QATEST	4.1254
NAS0E90D0	172.17.27.94	ADTEST	4.1254

Callout boxes describe the following elements:

- Name of Disk On-line Server (points to the Name column)
- IP address of Disk On-line Server (points to the IP Address column)
- Windows workgroup joined by Disk On-line Server (points to the Workgroup column)
- System version (points to the Version column)
- Exit the program (points to the Exit button)
- Configure the server name, time and network settings of Disk On-line Server (points to the Configure button)
- View the details of selected Disk On-line Server (points to the Details button)
- Map network drive for the server (points to the Map Drive button)
- Refresh the search results within the network (points to the Refresh button)
- View help message for Quick Install Wizard (points to the Help button)

Operation

1. Configure Disk On-line Server

Select a Disk On-line Server displayed on Quick Install Wizard and click **Configure**. Enter the administrator password.

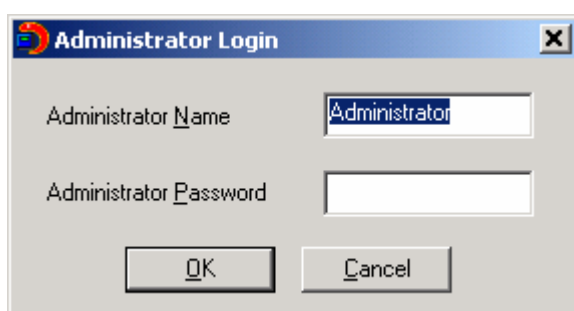
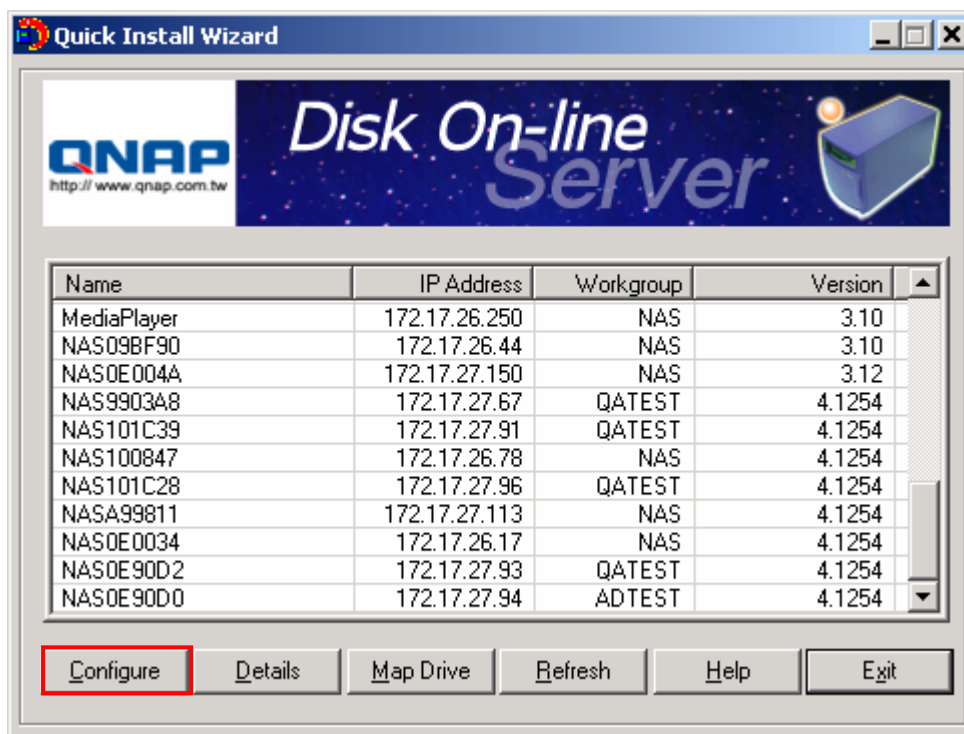

Upon successful login, the following screen will appear. Enter the configuration values and click OK.

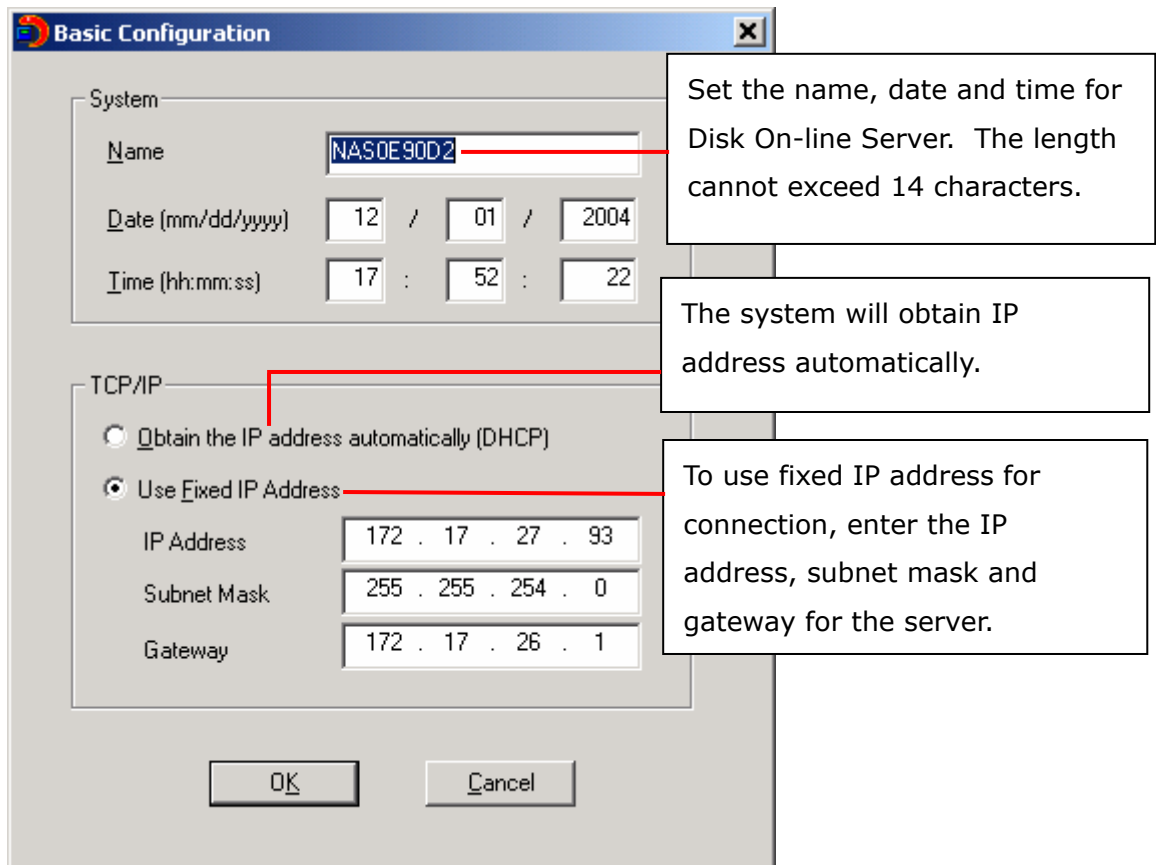

For further configuration of the system, please login the administration page of Disk On-line Server via web browser.

Note: You may have to restart Disk On-line Server after changing the network configuration.

2. View Disk On-line Server details

Select a Disk On-line Server available on Quick Install Wizard and click **Details**. The following screen will be shown:

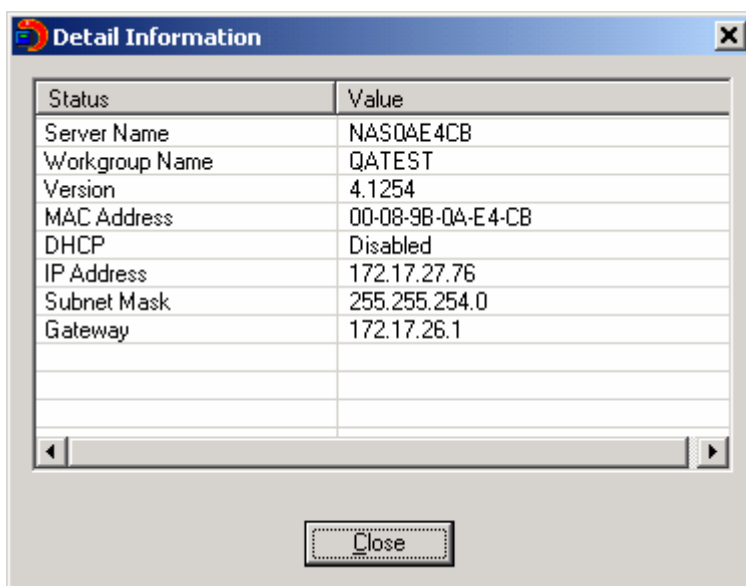
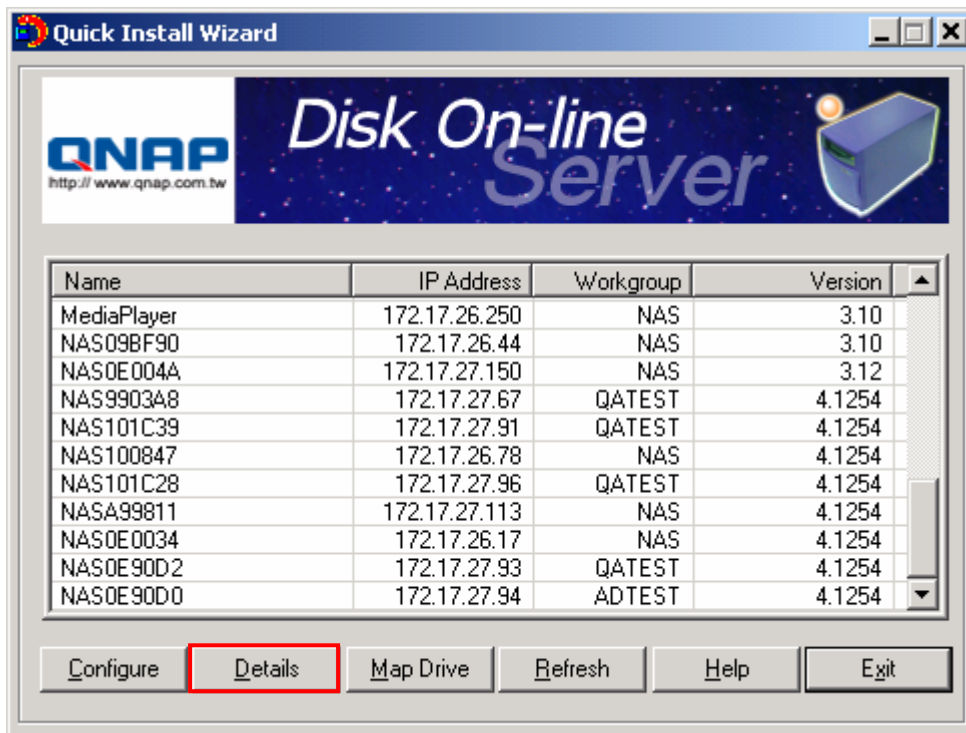

3. Map drive

- a. Select a Disk On-line Server and click **Map Drive**.

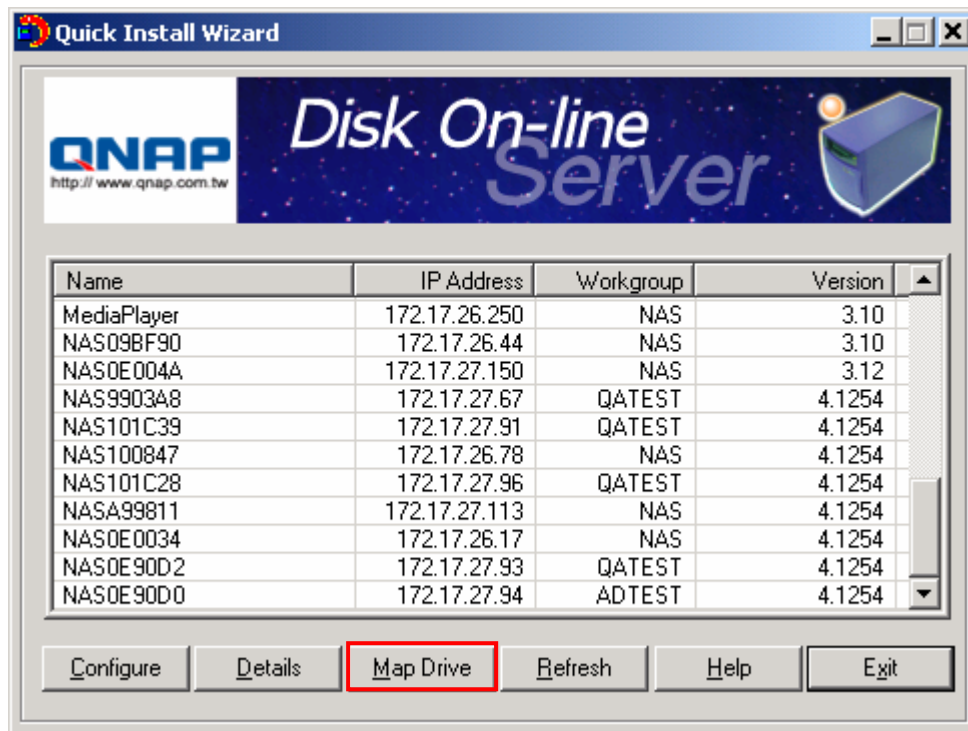

- b. Select the correct network share and click **Map Network Drive**. Then select the drive letter for connection.

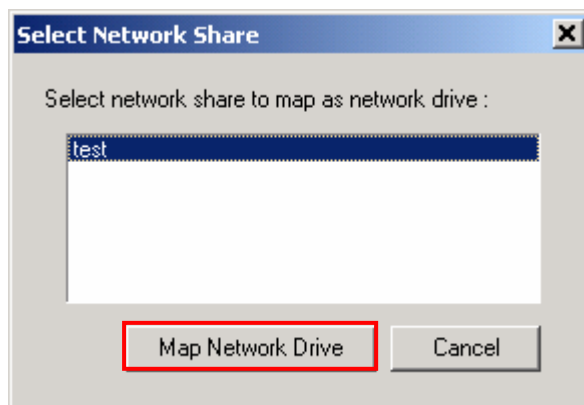

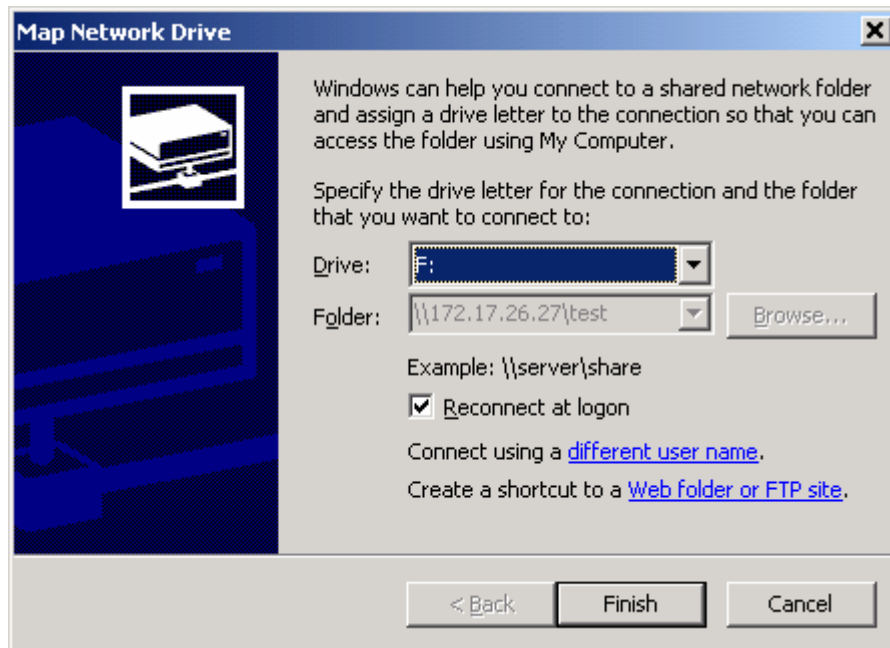

- c. Enter the password for the network drive.

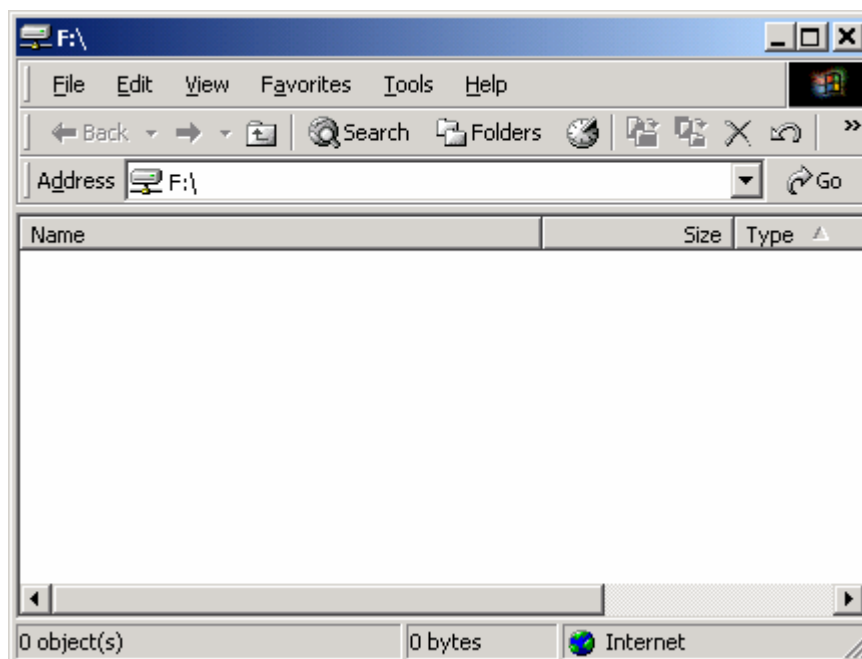
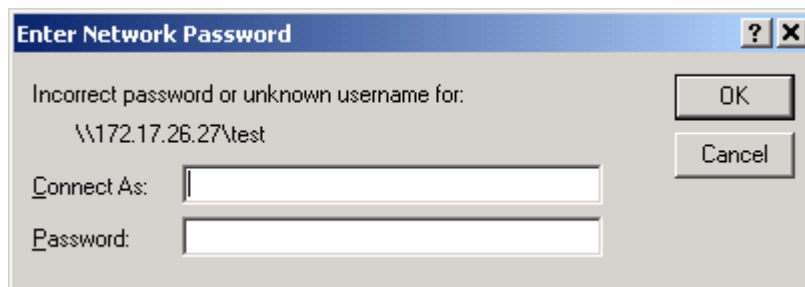

4. Search for all available Disk On-line Server again
To refresh the search results, click **Refresh** to display all available servers within the network.

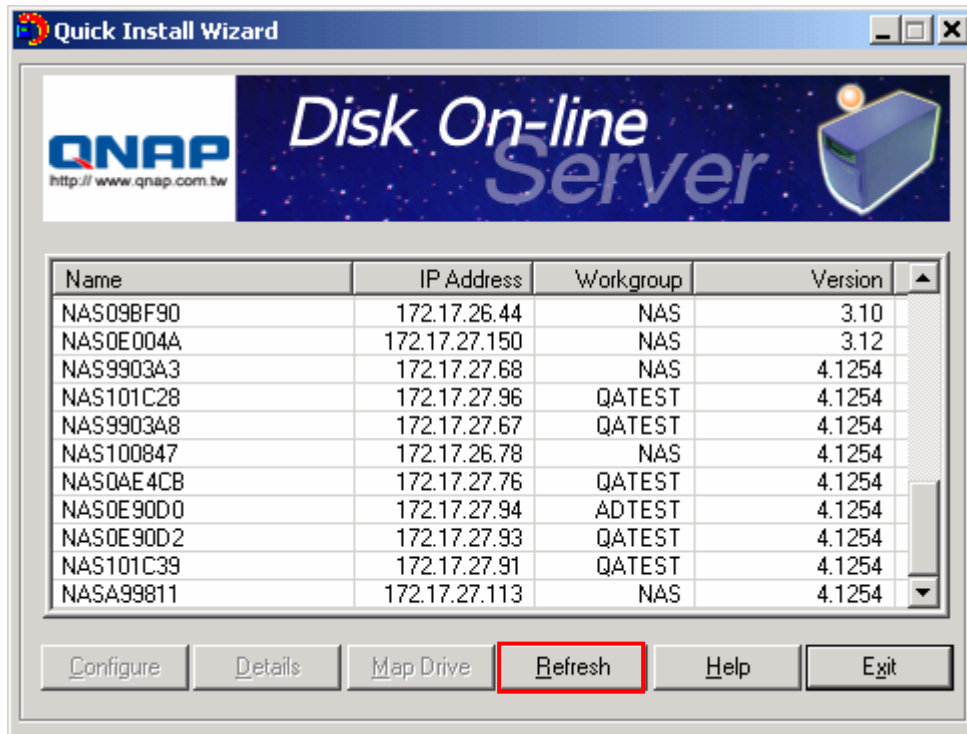

5. Help

Click **Help** to view the instructions of Quick Install Wizard.

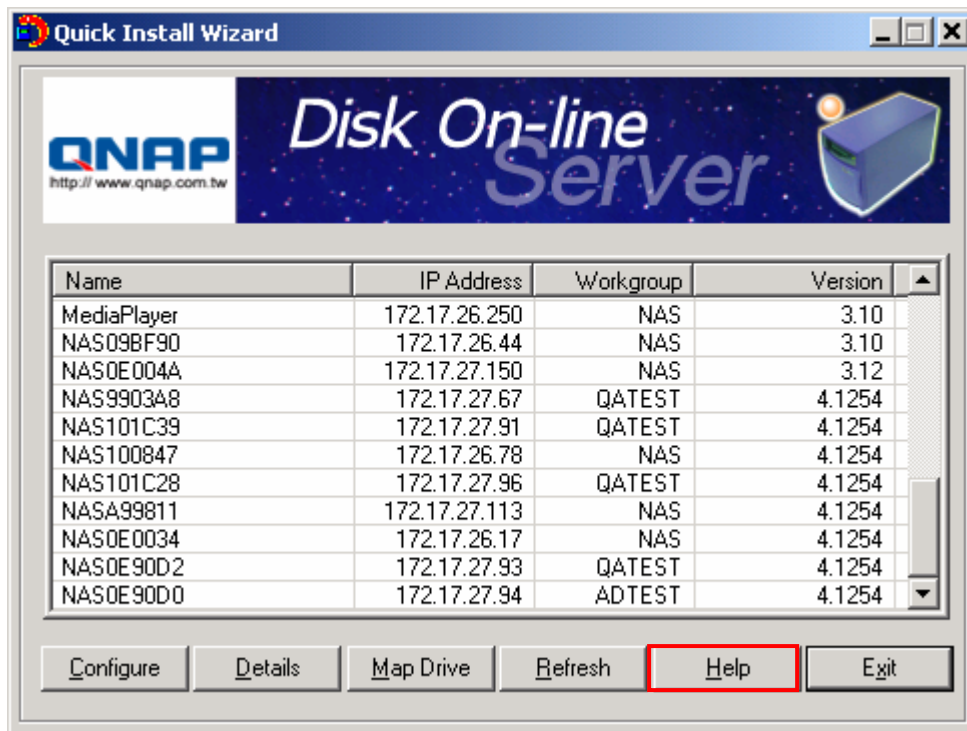

6. Enter the home page of Disk On-line Server

Double click on Disk On-line Server to enter the administration page.

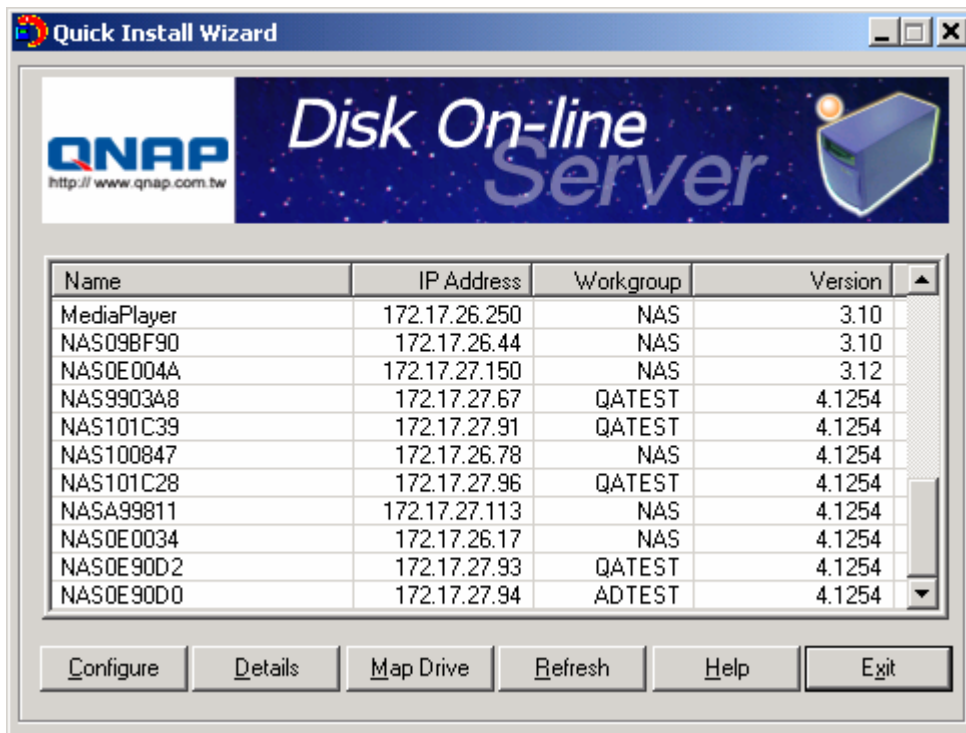

Appendix D NetBak Replicator

NetBak Replicator is a program installed in user's system (Windows only) for data backup. You can upload any files or folders to server and back up the data.

Main Functions

1. Backup

- File Filter

You can select particular file types to be excluded from backup. The system will filter all files belonging to these file types when backing up data.

- Schedule

You can specify a schedule for backing up data with this option, e.g. 12:00 every day or 05:00 every Saturday.

- Monitor

When this option is enabled, the system will upload all files or folders to the server instantly for backup when the files or folders are modified.

2. Restore

Select this option to restore backed up data to the original location of the file or to a new directory.

3. Log

Enable this option to record events of NetBak Replicator, e.g. the time when NetBak Replicator starts and terminates, Restore and Monitor, backup time and original location of all files, etc.

Installing Netbak Replicator

1. Run **Install NetBak Replicator** in the companion CD.



2. Follow the steps to install NetBak Replicator. Then click **Finish**.

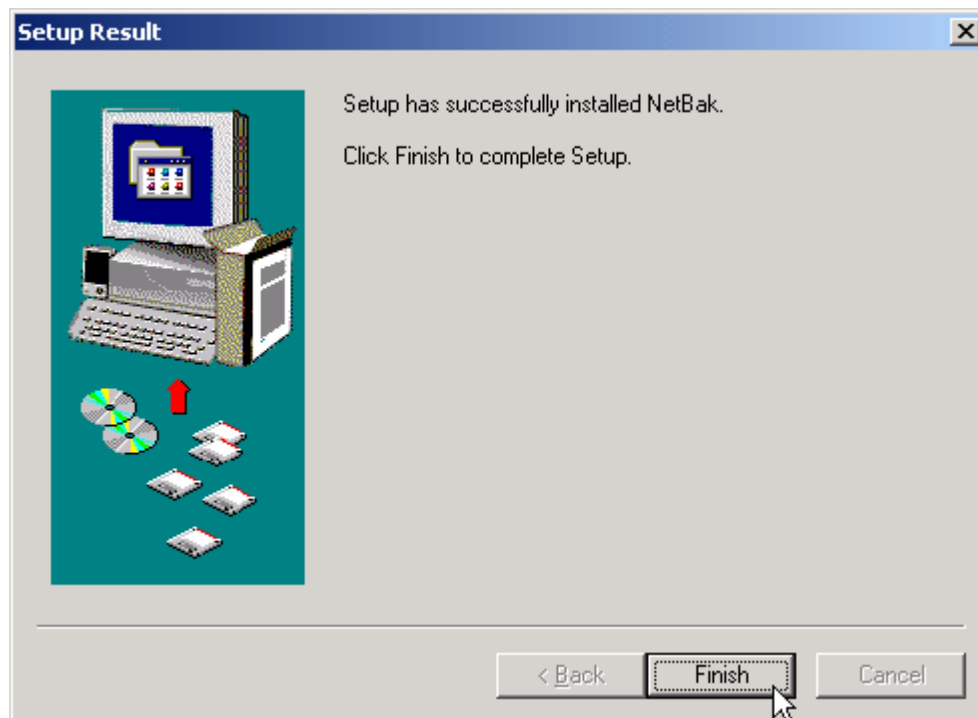

3. Upon successful installation, a shortcut icon  will be shown on the Desktop.

Using NetBak Replicator

1. Create a share folder for backup in NAS.

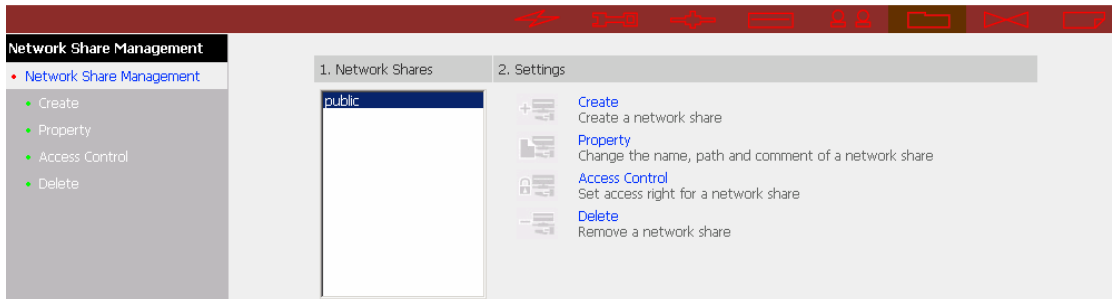

2. Run NetBak Replicator. Click . All NAS and their share folders within the network will be displayed.

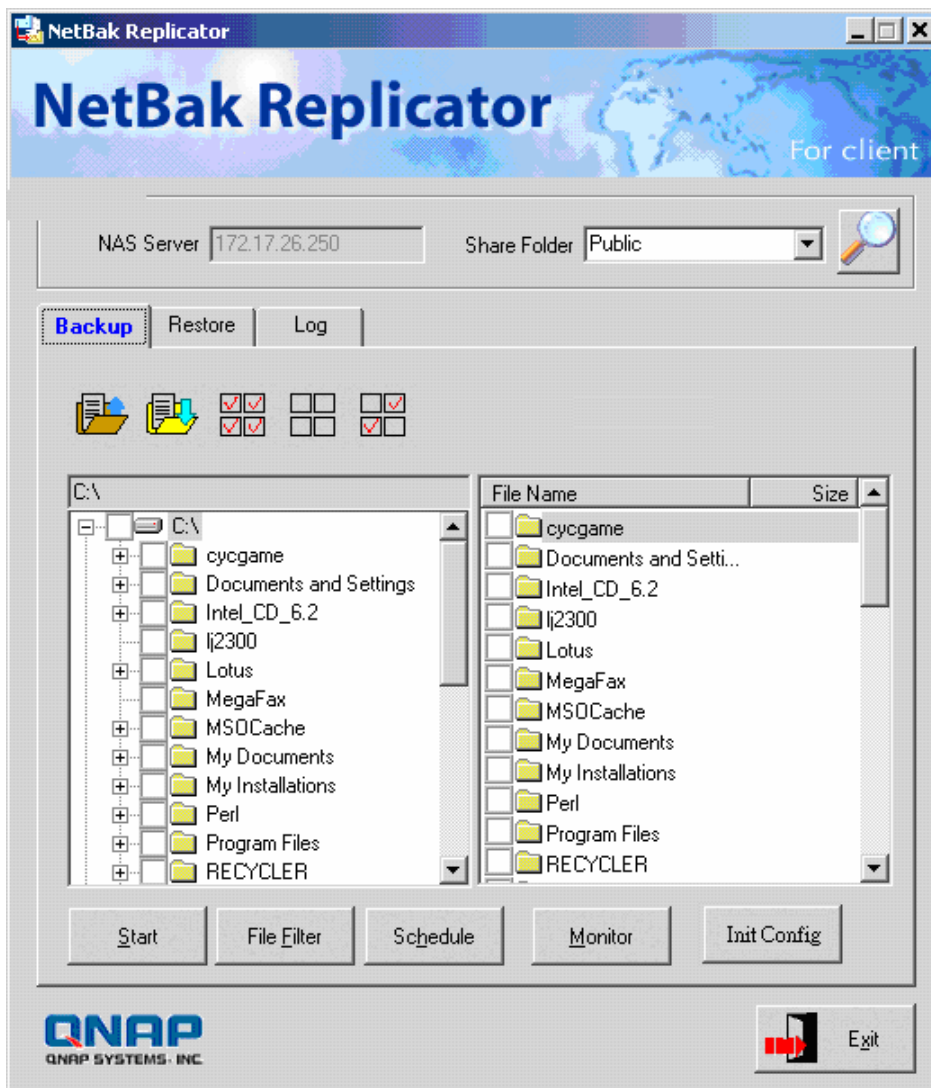

3. Select the server and share folder, or enter the IP address of NAS for data backup. Then click OK.

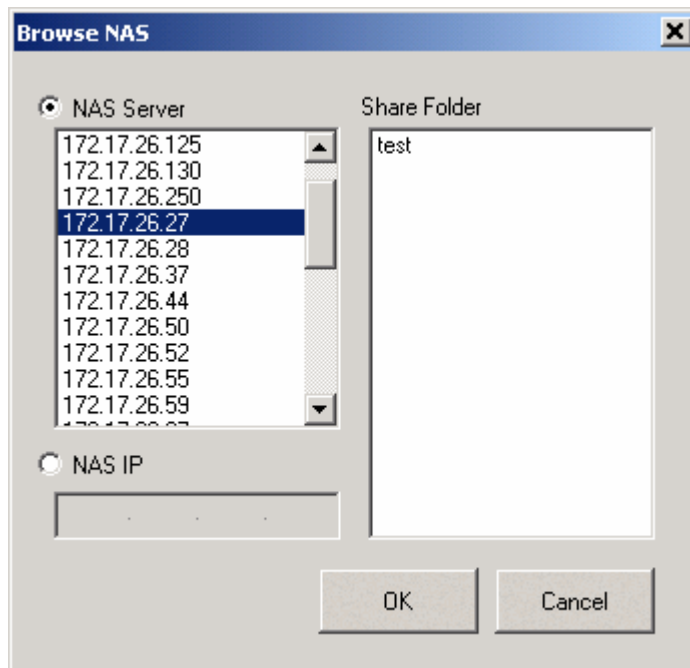

Note: Only authorized users can access the share folders. Double click the folder. The system will prompt for user name and password to authenticate the access privilege of the users.

4. You can start the backup procedure upon successful connection to the NAS.

- **Backup**

Select files and folders for backup.



- ✓ **File Filter**

Click **File Filter** to select file format to be skipped from backup. Then click OK.

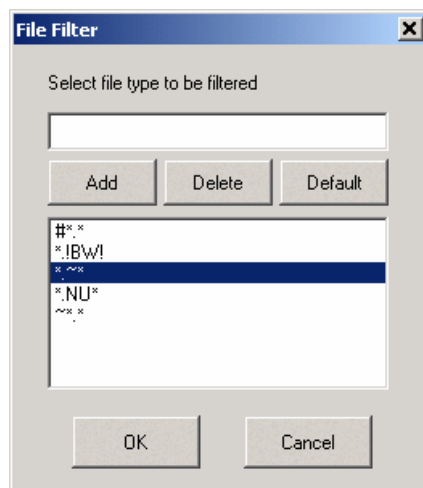

✓ Schedule

Click **Schedule** on NetBak Replicator main page. Then check the box "Enable Backup Schedule" and select the frequency and time for backup. Click OK to confirm.

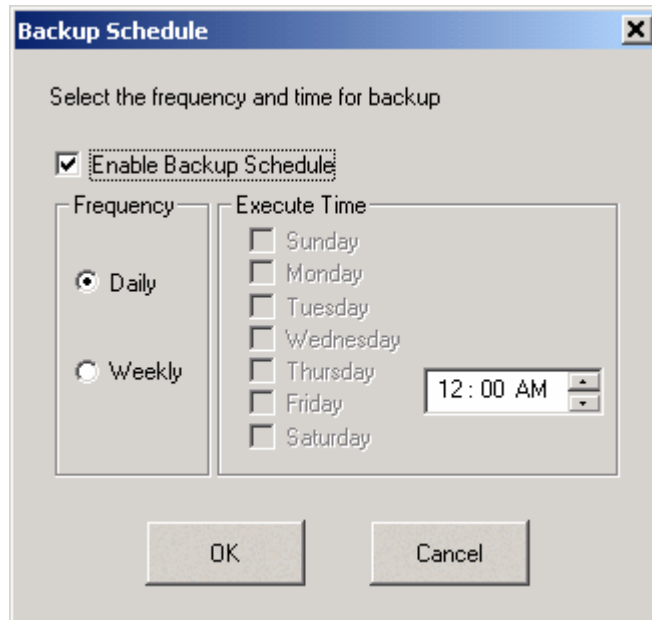

✓ Monitor

Select the files and folders for monitoring. Then click **Monitor**.

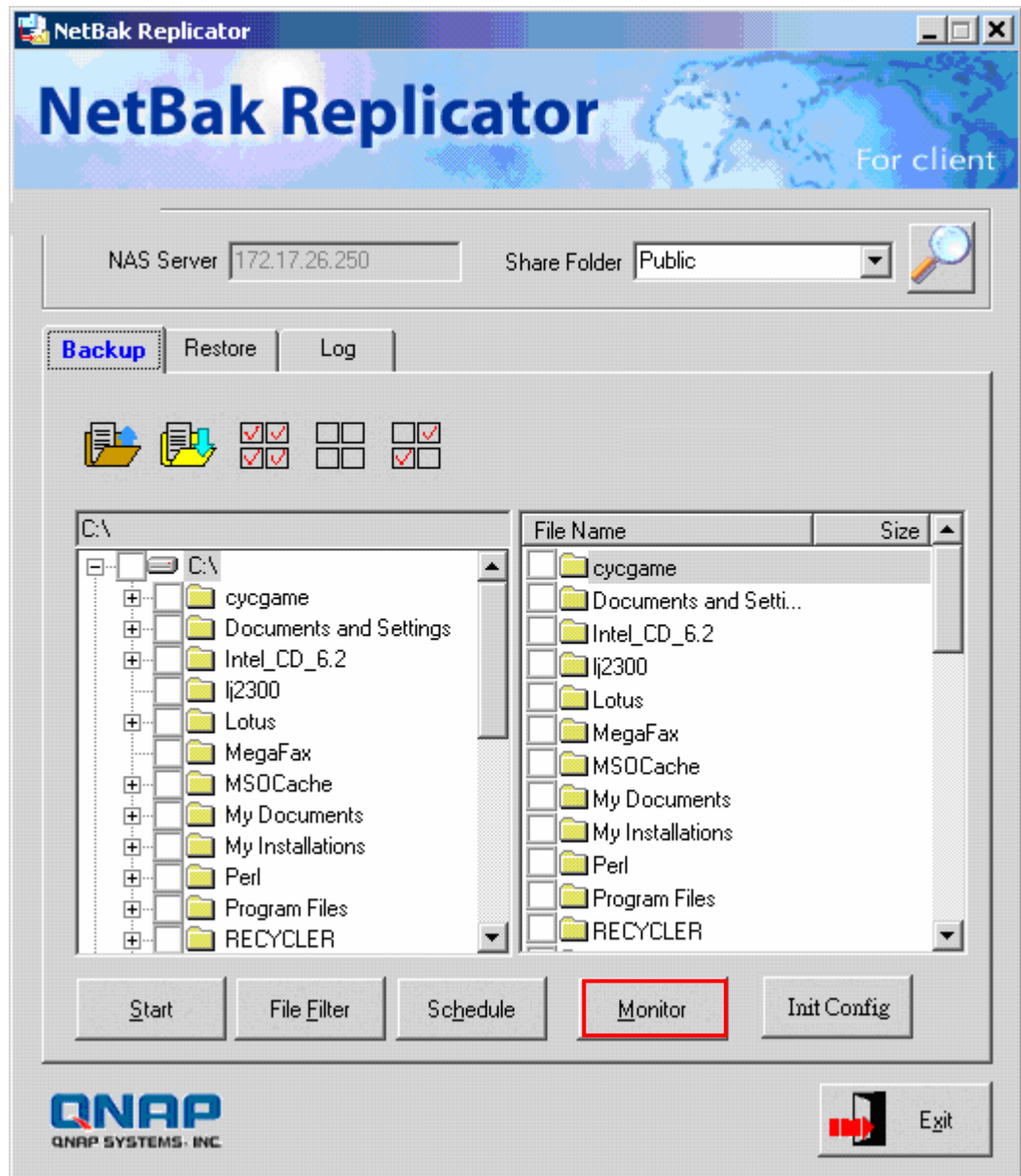

✓ Initialize Configuration

When using this function, NetBak Replicator will record all current settings of the user, including whether or not monitor function is enabled. When the user login again, this program will load the previous recorded settings for users to manage data backup.

- **Restore**

- a. Restore to original position: Select the location that the data will be restored to.
- b. Select new restore position: Click  to select the directory to restore data to or select a previously chosen location from the drop-down menu.
- c. Start: Select the folder(s) and sub-folder(s) for restoring data.

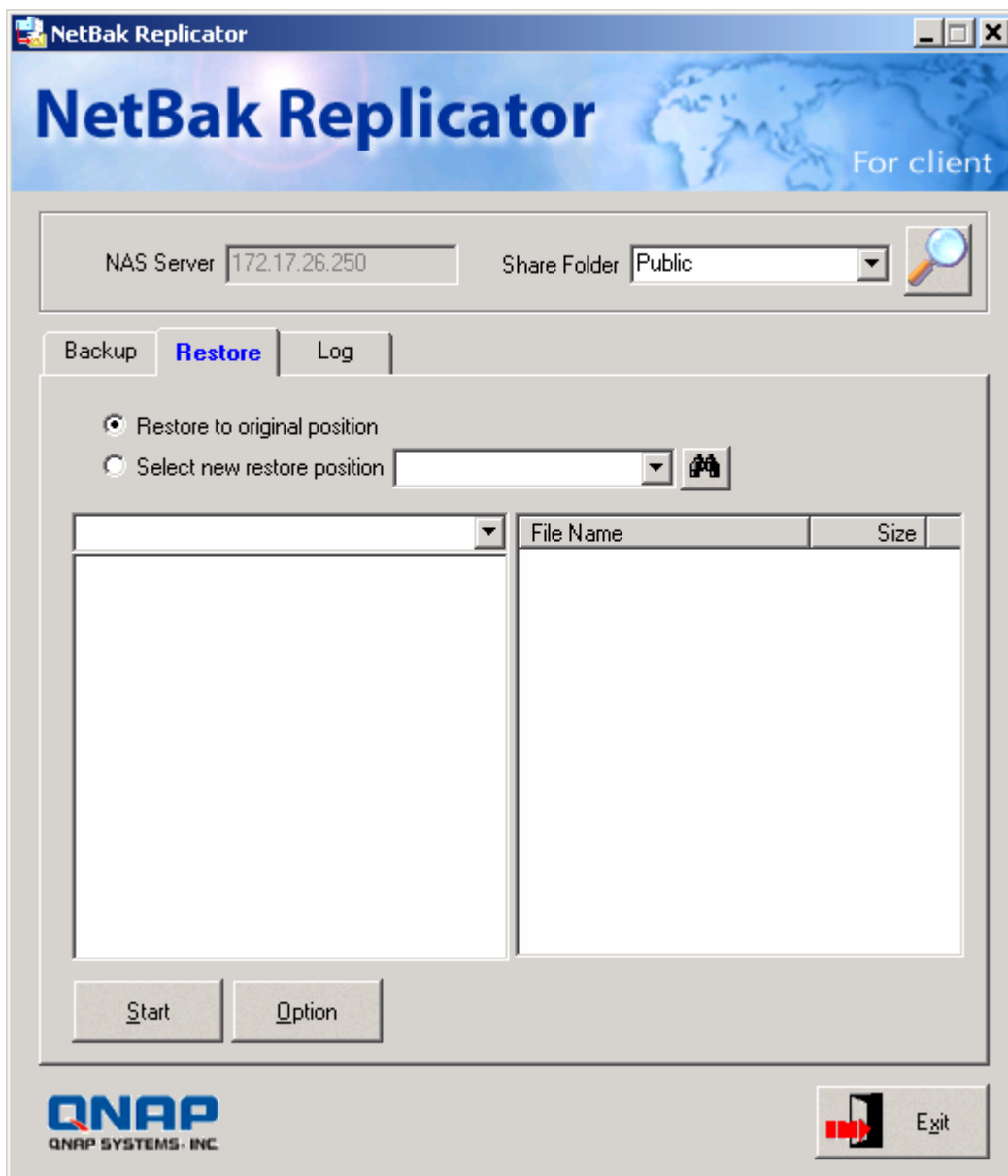

d. Option: Select recovery option and error option.

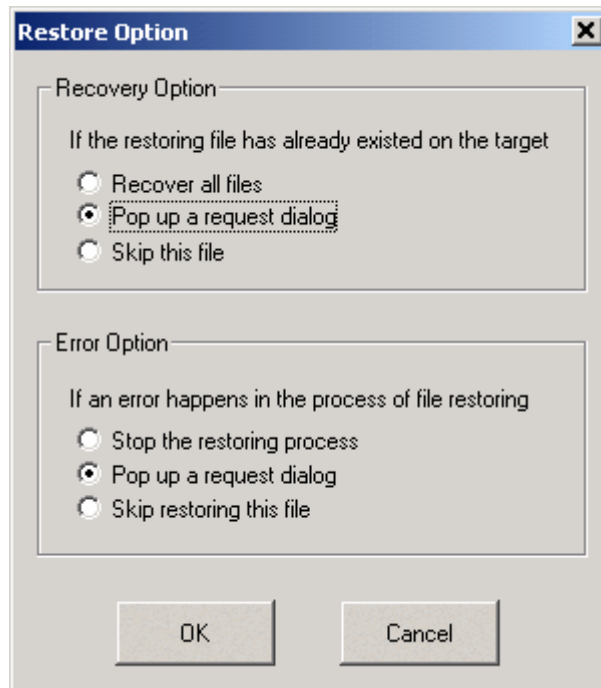

- **Log**

- Clear All: Click this button to clear all logs.
- Option: Select the type of logs to be recorded— “Record all logs” or “Record error logs only”.

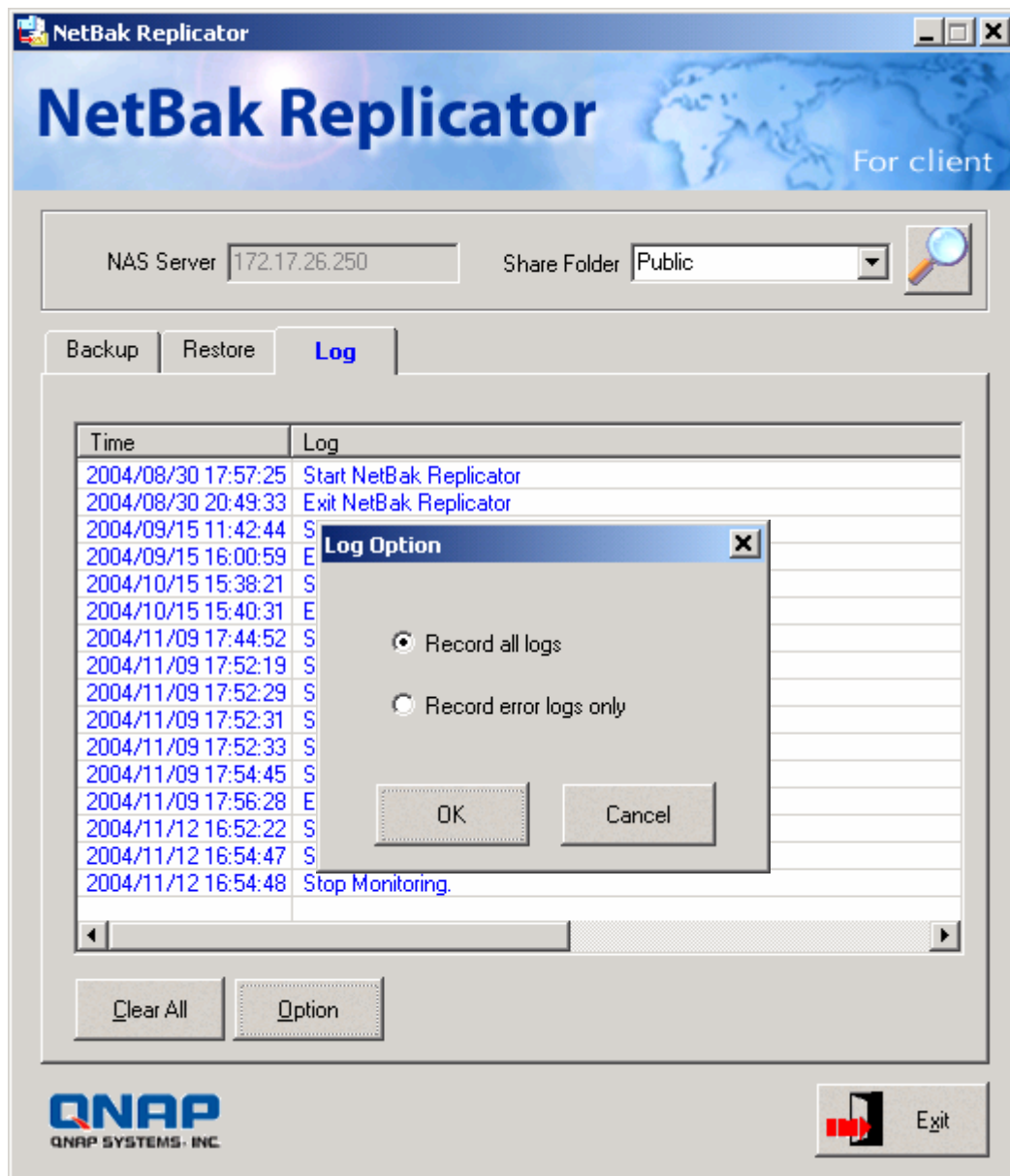

Appendix E Configuring AD Authentication

Environment

AD environment mixed mode can be supported by NAS firmware version 4.1.3. For example, qatest.com.tw and sub2.qatest.com.tw are domains controlled by Windows 2003 server, and sub1.qatest.com.tw domain is controlled by Windows 2000 server.

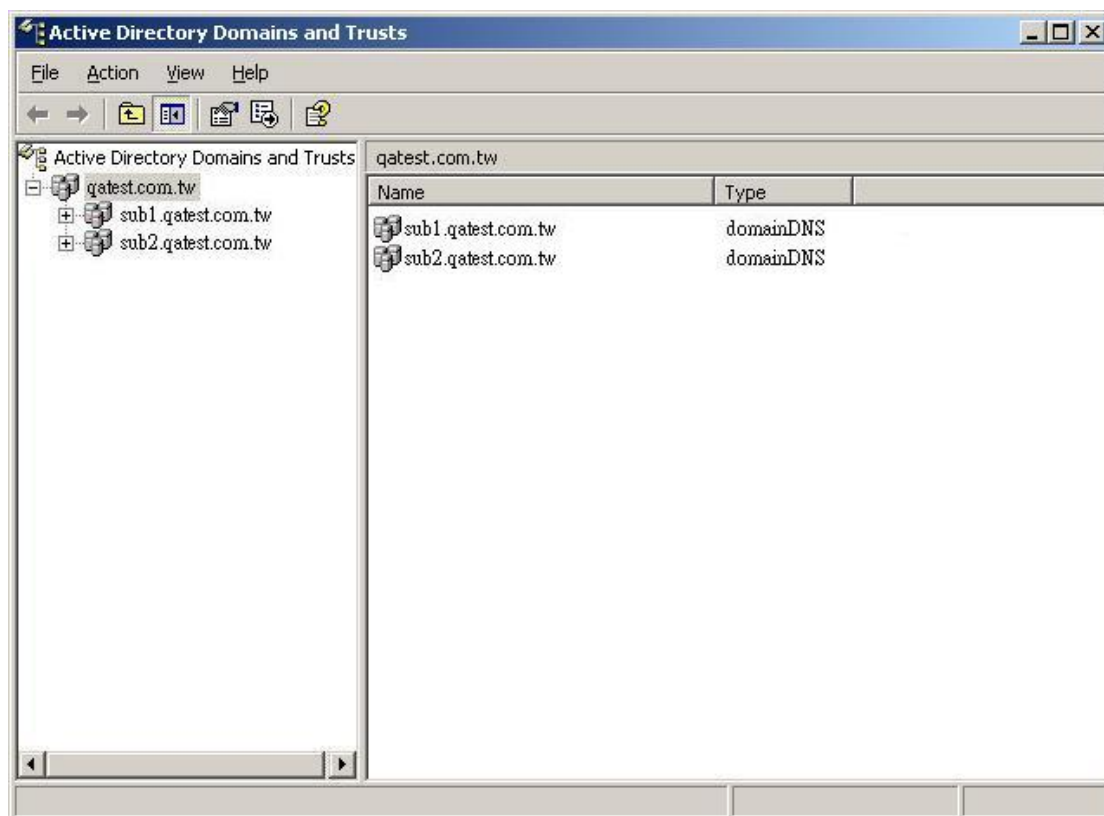

Adding NAS to Windows Server 2003 Active Directory Domain

1. Go to TCP/IP Configuration in Network Settings. Enter the IP address of primary DNS server. You can inquire AD domain via this DNS server.

The screenshot shows the 'TCP/IP Configuration' dialog box in Windows Server 2003. The 'Use static IP address' radio button is selected. The 'Primary DNS Server' field is highlighted with a red rectangle and contains the IP address 172.17.27.80. Other fields include Fixed IP Address (172.17.27.68), Subnet Mask (255.255.254.0), Default Gateway (172.17.26.1), and Secondary DNS Server (0.0.0.0). The 'Enable DHCP Server' checkbox is unchecked. The 'Configuration of Network Interfaces' section shows 'Load Balance' selected. The 'Network Speed' dropdown is set to 'auto-negotiate'. An 'Apply' button is visible at the bottom right.

Field	Value
Obtain IP address settings automatically via DHCP	<input type="radio"/>
Use static IP address	<input checked="" type="radio"/>
Fixed IP Address	172 . 17 . 27 . 68
Subnet Mask	255 . 255 . 254 . 0
Default Gateway	172 . 17 . 26 . 1
Primary DNS Server	172 . 17 . 27 . 80
Secondary DNS Server	0 . 0 . 0 . 0
Enable DHCP Server	<input type="checkbox"/>
Start IP Address	172 . 17 . 0 . 100
End IP Address	172 . 17 . 0 . 200
Lease Time	1 Day(s) 0 Hour(s)
Primary DNS Server	0 . 0 . 0 . 0
Secondary DNS Server	0 . 0 . 0 . 0
Configuration of Network Interfaces	<input type="radio"/> Fail Over <input checked="" type="radio"/> Load Balance
Network Speed	auto-negotiate

2. Go to Microsoft Networking of Network Settings. Enable AD Domain Member, and enter the domain name and the user name with administrator access right to that domain.

Microsoft Networking

Enable file service for Microsoft networking

Standalone Server

NT Domain Member

AD Domain Member

Server Description: NAS Server

Workgroup: QATEST

Domain Name: gatest.com.tw

Domain Username: administrator

Password: [masked]

Enable WINS server

Use the specified WINS server

WINS server IP address: [] . [] . [] . []

Apply

Note:

- (1) Make sure that a fully qualified domain name such as gatest.com.tw has been filled in.
- (2) Make sure the user name with administrator access right to that domain.

3. When the following message appears after applying the settings in step 2, check the DNS IP.

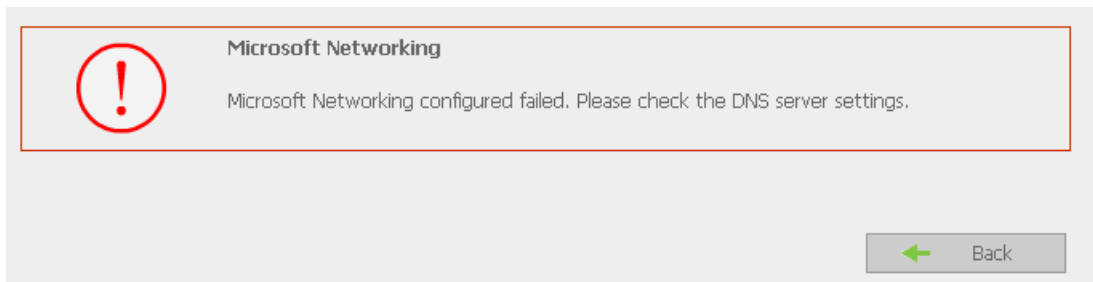

- When the following message appears after applying the settings in step 2, domain name, domain user name, and the password.

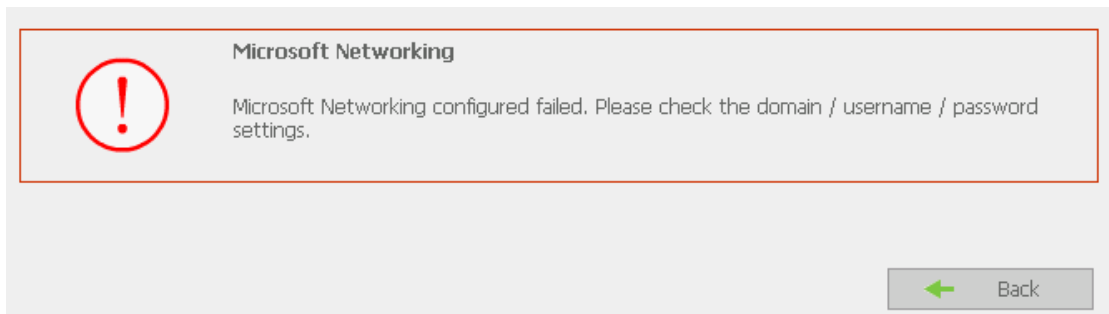

- When the following message appears after applying the settings in step 2, check the time zone settings. Make sure the difference of your time and that of AD server is less than 5 minutes. If the time difference is larger than 5 minutes, you will not be able to add the domain member.

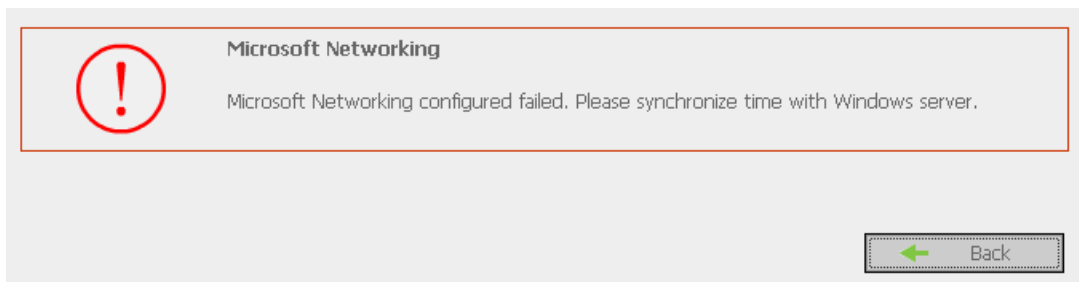

- Upon successful adding of domain member, you can view the list for domain users and local users in User Management.

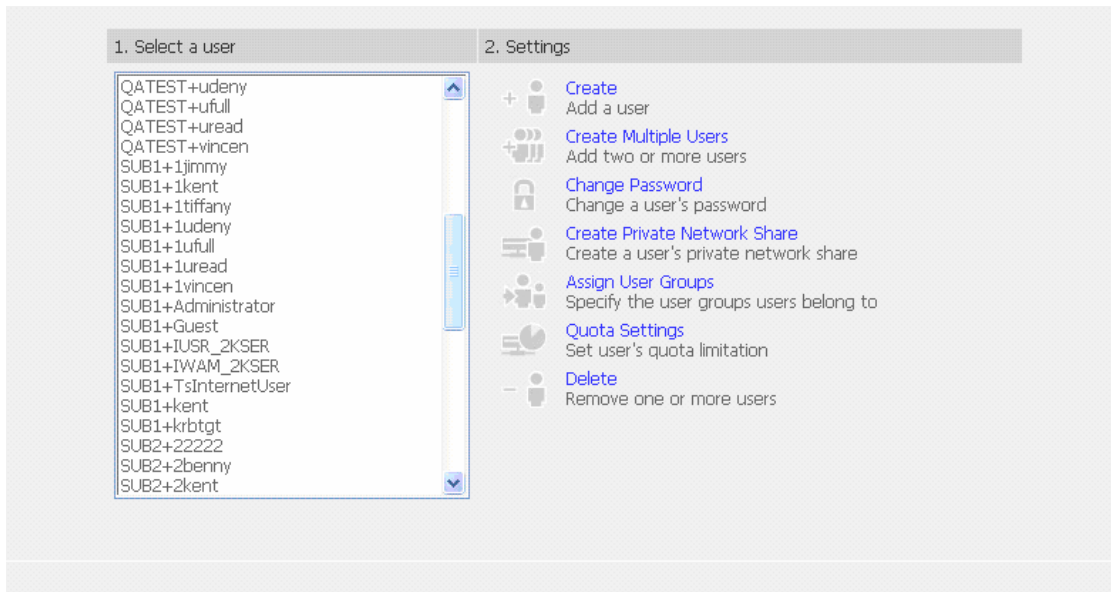

- Go to Access Control in Network Share Management to configure the access control right of AD users for all available network shares.

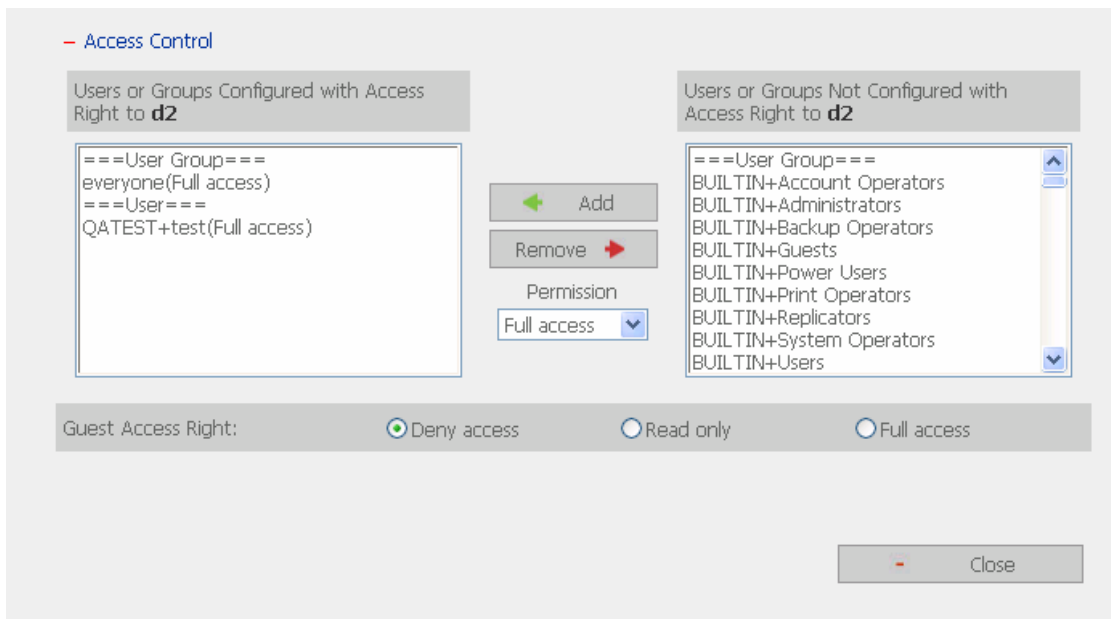

Using AD users to access services

To access services like FTP, Network Neighborhood, Apple Talk with an AD user account, add **DomainName** before the user name when logging in.

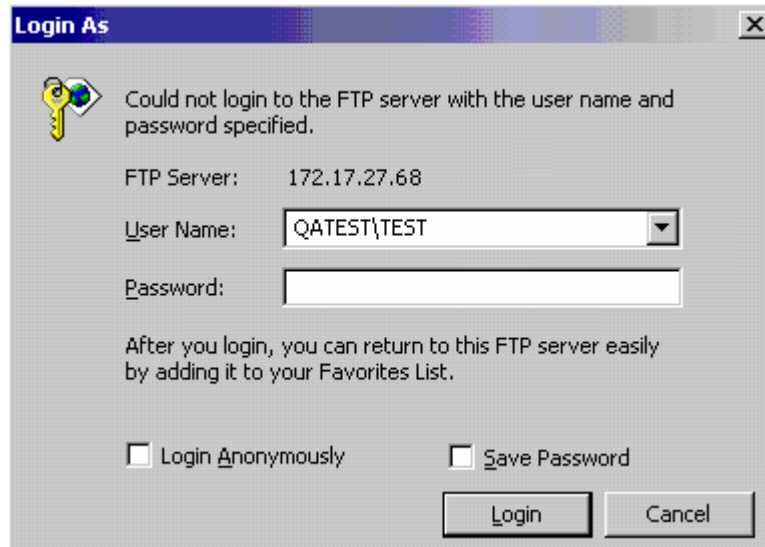

Adding NAS to Windows Server 2000 NT Domain

1. Go to Microsoft Networking to enable NT Domain member and then enter the domain name such as sub1 and the user who has administrator access right for identification.

Microsoft Networking

Enable file service for Microsoft networking

Standalone Server

NT Domain Member

AD Domain Member

Server Description: NAS Server

Workgroup: QATEST

Domain Name: sub1

Domain Username: administrator

Password: [masked]

Enable WINS server

Use the specified WINS server

WINS server IP address: [] . [] . [] . []

Apply

Note:

- (1) Please notice that NAS and Windows 2000/2003 server must be in the same section or the system will show the following error message.

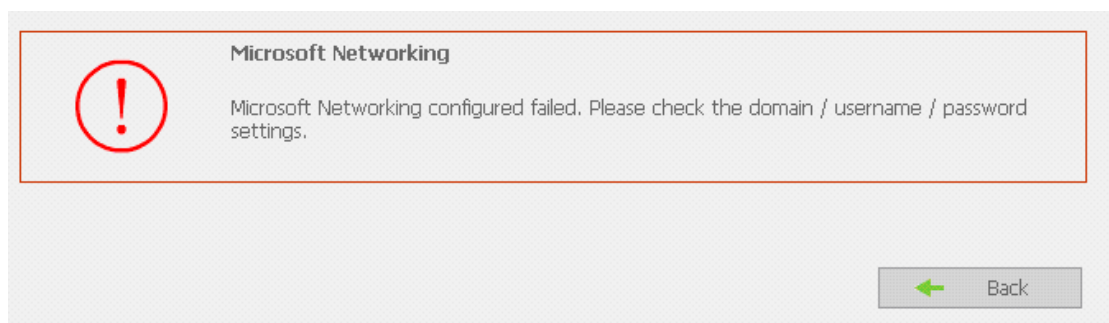

- (2) Make sure that a domain name such as sub1 has been filled in.
- (3) Make sure the user name with administrator access right to that domain.

- When the following message appears after applying the settings in step 1, check the domain name, domain user name, and the password.

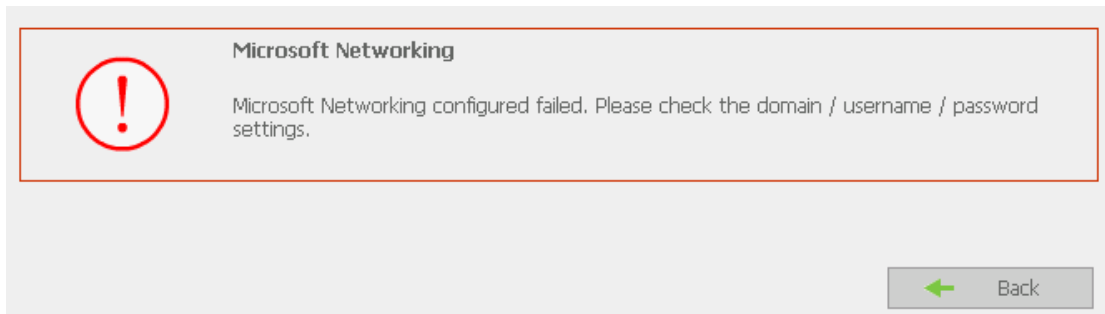

- When the following message appears after applying the settings in step 2, check the time zone settings. Make sure the difference of your time and that of AD server is less than 5 minutes. If the time difference is larger than 5 minutes, you will not be able to add the domain member.

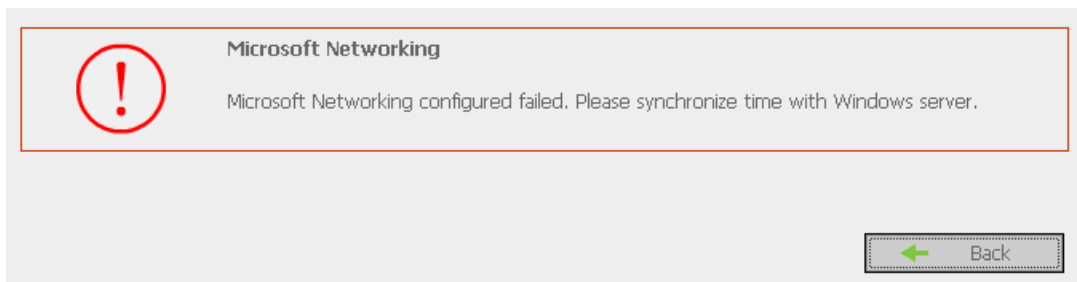

- Upon successful adding of domain member, you can view the list for domain users and local users in User Management.

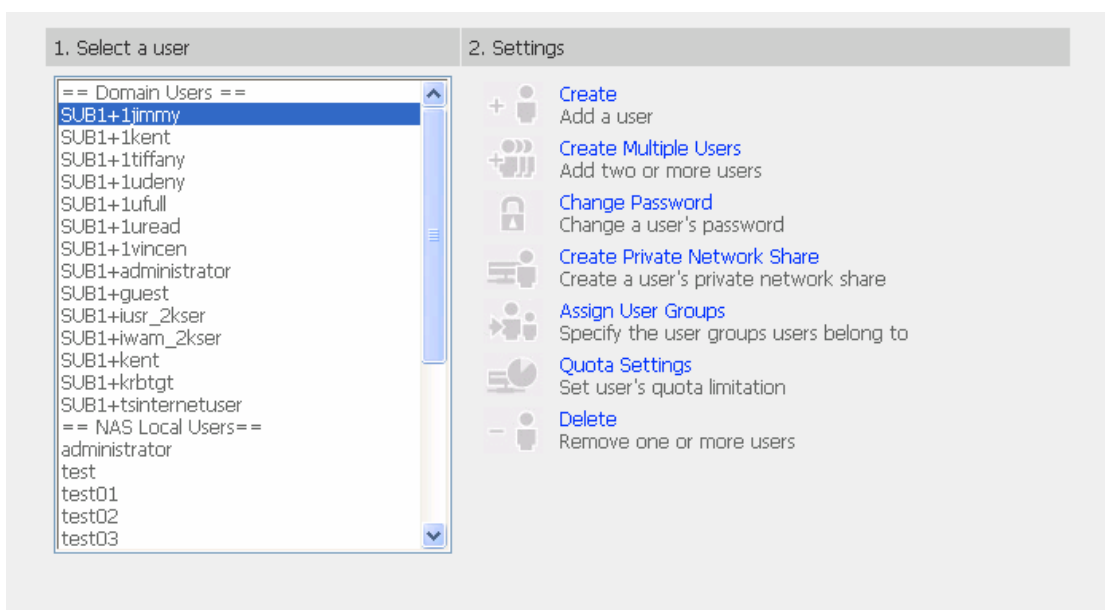

- Go to Access Control in Network Share Management to configure the access control right of domain users for all available network shares.



Using domain users to access services

To access services like FTP, Network Neighborhood, Apple Talk with an domain user account, add **DomainName** before the user name when logging in.

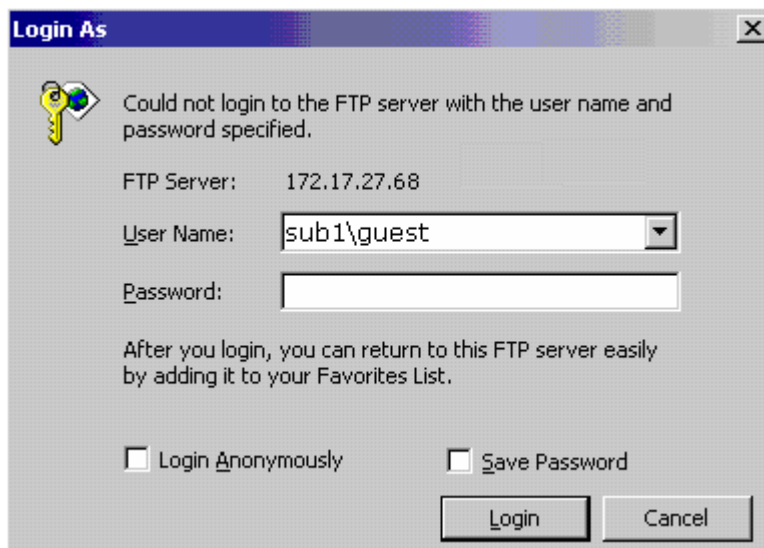

Note:

To join AD domain again, set NAS as standalone server in Microsoft Networking section. Make sure all domain users are removed in User Management before joining NAS to AD domain.

Appendix F Messages of Hard Disk and Disk Configuration Status

Status Description for Hard Disk and Disk Configuration

Hard Disk

English Display	Status Description
Ready	The hard disk status is normal
No disk	No disk currently ✓ Disk tray is not installed or there is main board error. Users can check disk tray. If there is main board error, please contact QNAP customer service.
Invalid	Indicates the disk does not have a record on NAS ✓ The disk is used on NAS the first time, or the disk on the same NAS model is used. Users can re-configure disk volume.
R/W error	Disk fails ✓ When R/W error is shown, users should back up data immediately and replace the failed disk.

Disk Configuration/ RAID Configuration

English Display	Status Description
Initializing	Initializing disk
Formatting	Formatting disk
Creating	Creating RAID configuration
Removing	Removing RAID configuration
Rebuilding	Rebuilding RAID configuration
Checking	Error checking on hard disk or disk configuration in process ✓ NAS will check disk automatically if it is shut down improperly

English Display	Status Description
Ready	The status of current disk or disk configuration is normal
Unmounted	Hard disk is not installed or hard disk configuration is not configured
Not Active	RAID configuration is damaged and cannot be enabled ✓ When this message is shown, users should back up disk data immediately and replace the failed disk.
Uninitialized	Initialization fails ✓ Single disk does not support hot swap. If the hard disk is unplugged when NAS is turning on, disk configuration will be damaged and will lead to data loss.

In degraded mode	A disk of RAID 1 or RAID 5 configuration is unplugged or fails. RAID data protection mechanism fails. ✓ In this situation, users should back up disk data immediately and replace the failed disk to rebuild RAID configuration.
------------------	---

Note:

1. When R/W error is displayed for hard disk status, or "Not active" or "In degraded mode" is displayed for RAID configuration, please replace the hard disk immediately to ensure RAID data protection can work properly. QNAP is not responsible for any data loss caused by delay in replacing failed disks in a RAID configuration by users intentionally or unintentionally.
2. QNAP Systems, Inc. guarantees that all Disk On-line Server (NAS) released have passed strict and complete QA test and can operate properly in normal condition. QNAP offers conditional and limited maintenance for NAS within warranty period. However, QNAP disclaims the responsibility for any data loss or damage, or business loss of users. In no event shall the liability of QNAP exceed the price paid for the product from direct, indirect, special, incidental, or consequential software, or its documentation.