

**LIQUID CRYSTAL DISPLAY MODULE**

**G 1 2 1 6 B 1 N 0 0 0**

**USER'S MANUAL**

Seiko Instruments Inc.

This manual provides technical information covering functions and operational instructions for the G1216 liquid crystal display modules made by Seiko Instruments Inc. Please read through this manual before operating the product. Distribution of this manual to third parties for any purpose other than operation of the product is prohibited. The descriptions herein are subject to change without prior notice.

## Revision Record

<u>Version</u>	<u>Revision</u>	<u>Date</u>
1	Original	December 1993

Copyright© 1993 by Seiko Instruments Inc.

Printed in Japan

**CONTENTS**

1.	GENERAL	
1.1	General .....	1
1.2	Features.....	1
1.3	Absolute Maximum Ratings (excluding LED backlight).....	2
1.4	Mechanical Characteristics.....	2
1.5	Electrical Characteristics (excluding LED backlight) .....	2
1.6	Optical Characteristics.....	3
1.7	LC Panel Life Time .....	4
1.8	LED Backlight Characteristics .....	4
1.9	Dimensions.....	6
2.	CIRCUIT CONFIGURATION	
2.1	Block Diagram .....	7
2.2	Segment Drivers (HD61202) .....	7
2.3	Common Driver (HD61203).....	13
2.4	Bias Voltage Generator .....	13
3.	OPERATING INSTRUCTIONS	
3.1	Terminal Functions .....	14
3.2	Timing Characteristics .....	15
3.3	Reset Function .....	16
3.4	Instructions .....	17
3.5	Contrast Adjustment and Power Supply Example .....	21
3.6	LED Backlight Driver Example .....	21
3.7	MPU Connection Diagram.....	23
4.	PRECAUTIONS.....	24

## INDEX

## 1. GENERAL

### 1.1 General

The G1216 is a very thin LCD module on which a full-dot matrix LCD panel and a CMOS IC driver are integrated. The LCD panel used here features wide viewing angle and high contrast. This full dot configuration allows a wide variety of patterns to be displayed depending upon the input data. The display position is the intersection point of the matrix transparent electrodes. This prevents display distortion and displacement. Incorporating a display RAM and a display timing signal generator into the G1216 allows for direct connection with the MPU circuit without using an LCD controller.

### 1.2 Features

- 128×64 full dot matrix configuration
- 1/64 duty, 1/9 bias
- Two 4096-bit internal display data RAMs
- An internal display timing signal generator
- 8-bit parallel interface
- Instructions:  
Display Data Read/Write, Display ON/OFF, Display Start Line, X-Address (Page) Set, Y- Address Set, and Status Read.
- Three types of power supply: VDD=+5 V, VLC , LEDA (LED anode)
- Transflective, gray mode
- Positive display  
Display data "H": Display ON: blue display color  
Display data "L": Display OFF: gray background
- A wide operating temperature range
- A built-in LED backlight (color: yellow-green)

## 1.3 Absolute Maximum Ratings (excluding LED backlight)

V<sub>SS</sub> = 0 V

Item	Symbol	Conditions	Min.	Max.	Unit
Power supply voltage	V <sub>DD</sub>	T <sub>a</sub> = 25°C	-0.3	7.0	V
	V <sub>LC</sub>	50±10%RH	V <sub>DD</sub> -19.0	V <sub>DD</sub> + 0.3	V
Input voltage	V <sub>IN</sub>		-0.3	V <sub>DD</sub> + 0.3	V
Operating temperature	T <sub>opr</sub>	≤ 65%RH	-20	+70	°C
Storage temperature	T <sub>stg</sub>	—	-30	+80	°C
Storage humidity	—	≤ 48 hrs	+20	+85	%RH
	—	≤ 1000 hrs	+20	+65	%RH

## 1.4 Mechanical Characteristics

Item	Standard
Dot configuration	128×64 dot
Module dimensions ( H × V × T ) [ mm ]	75.0 × 52.7 × 8.9
Viewing area ( H × V ) [ mm ]	60.0 × 32.5
Active display area ( H × V ) [ mm ]	55.01 × 27.49
Dot dimensions ( H × V ) [ mm ]	0.4 × 0.4
Dot pitch ( H × V ) [ mm ]	0.43 × 0.43
Weight [ g ]	45 max.

H : Horizontal      V : Vertical      T : Thickness (max.)

## 1.5 Electrical Characteristics (excluding LED backlight)

V<sub>DD</sub> = 5 V±5%, V<sub>SS</sub> = 0 V, T<sub>a</sub> = -20°C to +70°C

Item	Symbol	Conditions	Min.	Typ.	Max.	Unit	
Input voltage <sup>1</sup>	High	V <sub>IHC</sub>	—	0.7V <sub>DD</sub>	—	V <sub>DD</sub>	V
	Low	V <sub>ILC</sub>	—	0	—	0.3V <sub>DD</sub>	V
Input voltage <sup>2</sup>	High	V <sub>IHT</sub>	—	2.0	—	V <sub>DD</sub>	V
	Low	V <sub>ILT</sub>	—	0	—	0.8	V
Output voltage <sup>3</sup>	High	V <sub>OH</sub>	I <sub>OH</sub> = -205 μA	2.4	—	—	V
	Low	V <sub>OL</sub>	I <sub>OL</sub> = 1.6 mA	—	—	0.4	V
Power supply voltage	V <sub>DD</sub>	—	4.75	5.00	5.25	V	
	V <sub>LC</sub>	—	-12.0	-8.0	-3.0	V	
Current consumption <sup>4</sup>	I <sub>DD</sub>	V <sub>DD</sub> =5 V, T <sub>a</sub> = 25°C	—	2.0	3.0	mA	
	I <sub>LC</sub>	V <sub>LC</sub> = -8.0	—	1.8	3.0	mA	
Frame frequency	f <sub>FRM</sub>	—	—	71.4	—	Hz	

<sup>1</sup> Applied to RST.<sup>2</sup> Applied to DB<sub>0</sub> to DB<sub>7</sub>, E, R/W, D/I, CS1 and CS2.<sup>3</sup> Applied to DB<sub>0</sub> to DB<sub>7</sub>.<sup>4</sup> Display patterns: checkered patterns.

## 1.6 Optical Characteristics

1/64 duty, 1/9 bias,  $f_{FRM} = 71.4 \text{ Hz}$ ,  $V_{opr} = V_{DD} - V_{LC}$ , LED backlight: OFF

Item	Sym.	Conditions	Temp.	Min.	Typ.	Max.	Unit	Remark
Viewing angle	$\theta_1$	$C \geq 2.0$ $\varnothing = 0^\circ$ $V_{opr}=13.0 \text{ V}$	25°C	—	—	-15	Degree	Refer to notes 1 and 2
	$\theta_2$			15	—	—		
	$\theta_2-\theta_1$			30	—	—		
	$\theta_1$	$C \geq 2.0$ $\varnothing = 270^\circ$ $V_{opr}=13.0 \text{ V}$	25°C	—	—	-20		
	$\theta_2$			50	—	—		
	$\theta_2-\theta_1$			70	—	—		
Contrast	C	$\theta = 0^\circ$ $\varnothing = 0^\circ$ $V_{opr}=13.0 \text{ V}$	25°C	2.5	3.5	—	—	Note 3
Response time	$t_{on}$	$\theta = 0^\circ$ $\varnothing = 0^\circ$ $V_{opr}=13.0 \text{ V}$	25°C	—	40	100	ms	Note 4
	$t_{off}$			—	100	200		
	$t_{on}$	$\theta = 0^\circ$ $\varnothing = 0^\circ$ $V_{opr}=14.0 \text{ V}$	-20°C	—	630	1000		
	$t_{off}$			—	2300	3500		

Measuring instrument : Canon illuminometer LC-3S

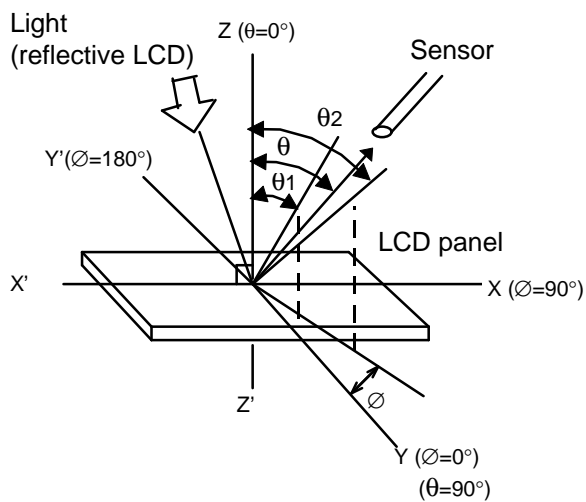
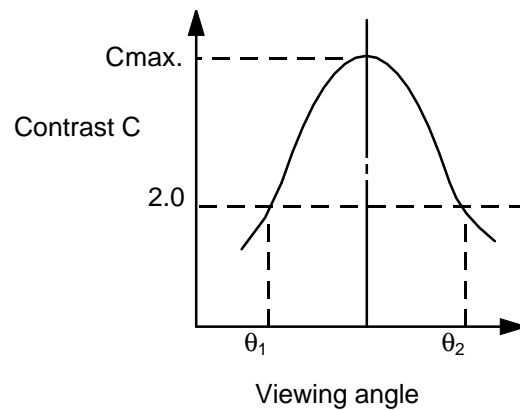
Note 1: Definition of angle  $\theta$  and  $\varnothing$ Note 2: Definition of viewing angles  $\theta_1$  and  $\theta_2$ 

Remark: The optimum viewing angle by visual inspection and angle  $\theta$  at  $C_{max}$  do not always match.

Note 3: Definition of contrast (C)

$$C = \frac{\text{Brightness of non-selected dot (reflection) } B_2}{\text{Brightness of selected dot (reflection) } B_1}$$

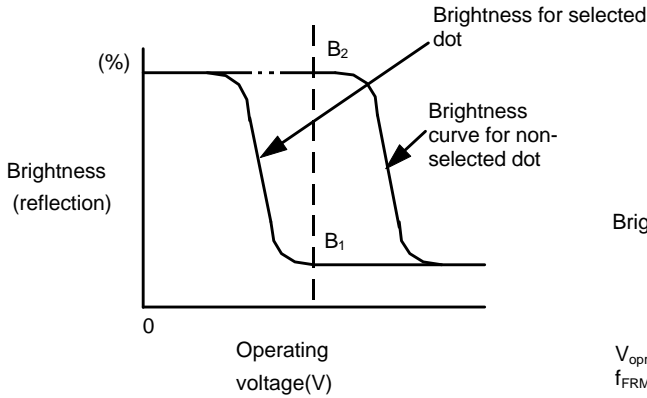

Note 4: Definition of response time

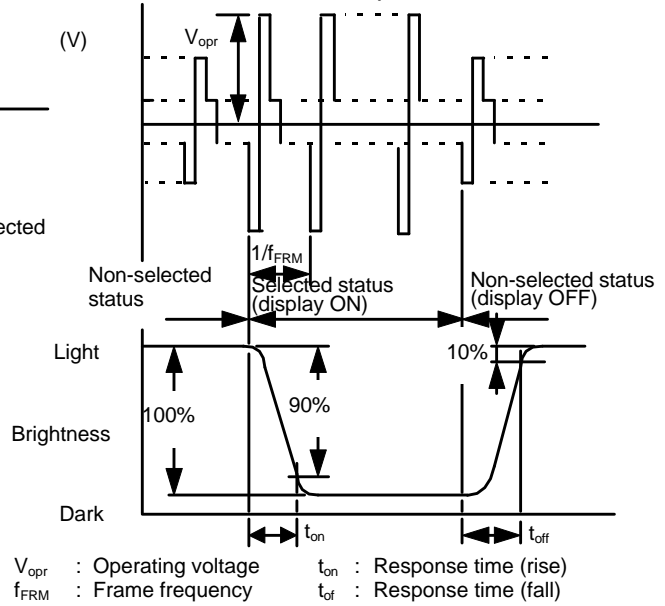

$V_{opr}$  : Operating voltage       $t_{on}$  : Response time (rise)  
 $f_{FRM}$  : Frame frequency       $t_{off}$  : Response time (fall)

Note: Measurement must be made using a transmissive LCD panel.

1.7 LC panel life time

Item	Conditions	Standard	Unit
Life time <sup>1</sup>	25°C±10°C <65%RH	100,000 or more	hrs

<sup>1</sup> Definition of life time: the time up to occurrence of any of the following:

- Contrast reduces to 30% of the initial value.
- Current consumption becomes three times the initial value.
- Orientation deteriorates significantly.
- The display malfunctions.

1.8 LED backlight characteristics

(1) Absolute maximum ratings

Item	Symbol	Standard	Unit
DC forward current	$I_F$	200*	mA
DC reverse voltage	$V_R$	8	V
Allowable dissipation	$P_D$	860	mW
Operating temp. range	$T_{opr}$	-20 to +70	°C
Storage temp. range	$T_{sta}$	-30 to +80	°C

\* Forward current reduction characteristics: The absolute maximum rating of the forward current varies depending on ambient temperature.

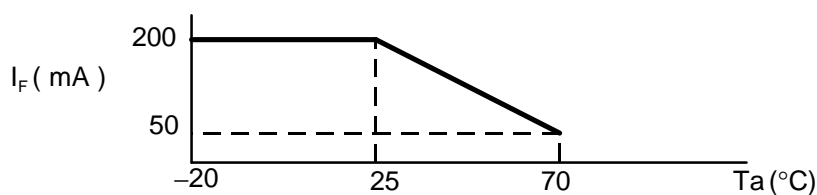

## (2) Electrical and optical characteristics

Ta = 25°C

Item	Symbol	Meas. condition	Min.	Typ.	Max.	Unit
Forward voltage	$V_F$	$I_F=90$ mA	3.8	4.1	4.4	V
Reverse current	$I_R$	$V_R=8$ V	—	—	0.9	mA

## (3) LED backlight connection diagram

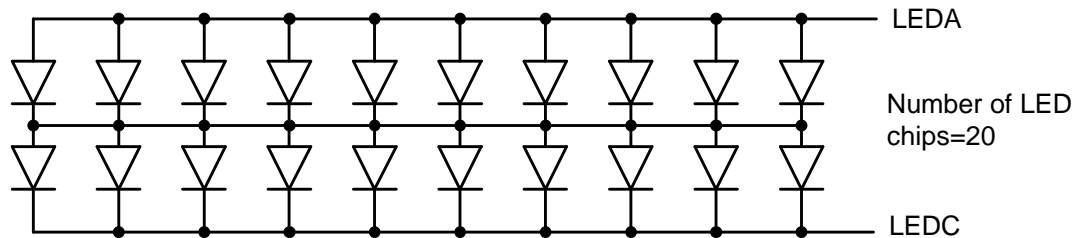

## (4) Brightness (panel upper side)

Item	Symbol	Min.	Typ.	Max.	Unit
Surface brightness (Center of LCD panel)	$B_p$	1.0	2.0	—	nit

Measurement conditions and a measuring instrument are:

- Ta=25°C±3°C
- 30 to 85%RH
- $I_F=90$  mA
- $f_{FRM}=71.4$  Hz
- $V_{LC}$ : Optimum LC drive voltage
- Display OFF (Entire display data="L")
- Measured 30 minutes after LED lights
- Measuring instrument: BM - 7 (TOPCON)

## (5) Life time

Item	Measurement conditions	Standard	Unit
Life time <sup>1</sup>	Ta=25°C±10°C $I_F=90$ mA	50,000 or more	hrs

<sup>1</sup> Definition of life time: The time until the brightness decreases to one half the initial brightness.



## 1.9 Dimensions

Unit: mm

General dimensional tolerance:  $\pm 0.5$ 

Figure 1 Dimensions

## I/O terminal functions

No.	Sym.	Functions
1	V <sub>DD</sub>	Power supply voltage: +5.0 V
2	V <sub>SS</sub>	GND: 0 V
3	V <sub>LC</sub>	LC drive voltage
4	DB <sub>0</sub>	Data bus (LSB)
5	DB <sub>1</sub>	Data bus
6	DB <sub>2</sub>	Data bus
7	DB <sub>3</sub>	Data bus
8	DB <sub>4</sub>	Data bus
9	DB <sub>5</sub>	Data bus
10	DB <sub>6</sub>	Data bus

No.	Sym.	Functions
11	DB <sub>7</sub>	Data bus (MSB)
12	CS1	Chip select (1)
13	CS2	Chip select (2)
14	RST	Reset
15	R/W	Read/Write
16	D/I	Data/Instruction
17	E	Enable
18	FGND	Frame ground <sup>1</sup>
19	LEDA	LED anode
20	LEDC	LED cathode

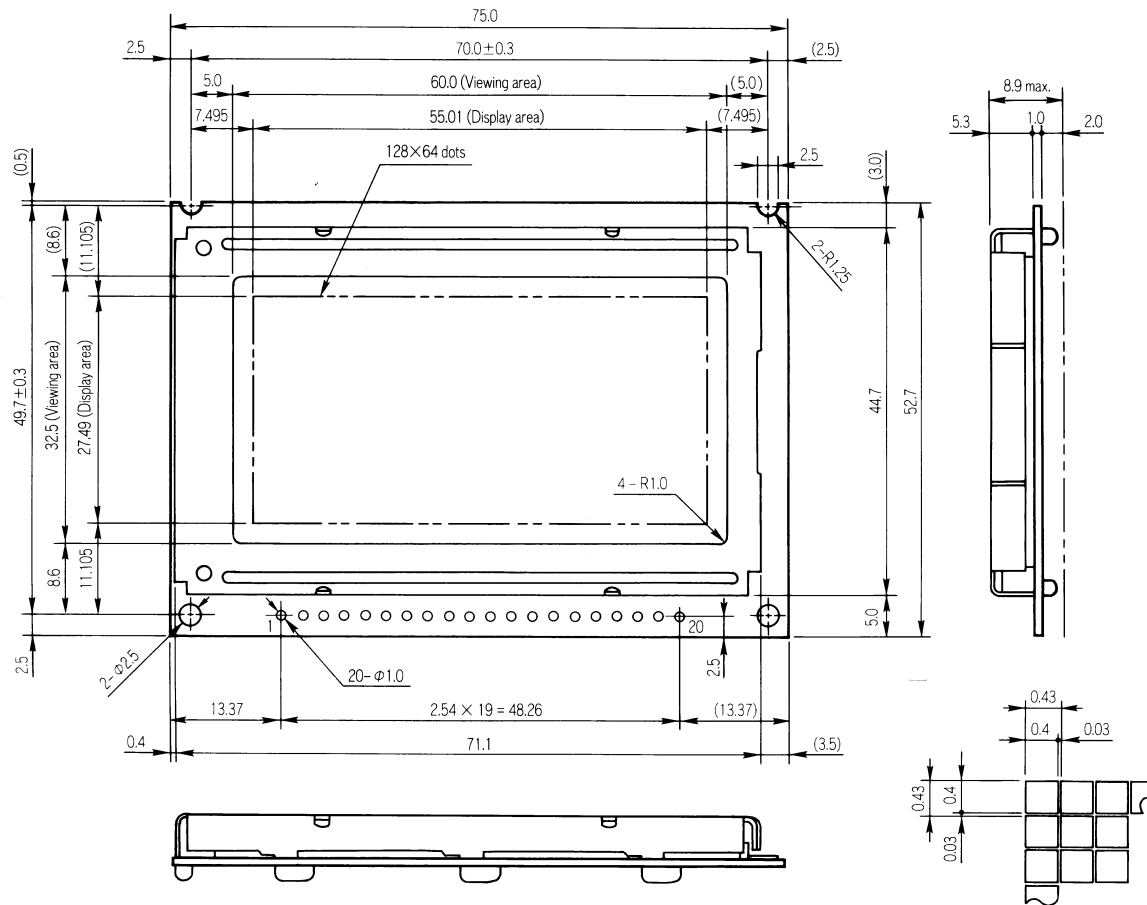
<sup>1</sup> FGND is connected to the metallic frame of the module. Use this frame when grounding.

## 2. CIRCUIT CONFIGURATION

### 2.1 Block Diagram

This product consists of two HD61202 segment drivers, an HD61203 common driver and a bias voltage generator. Figure 2 shows the block diagram.

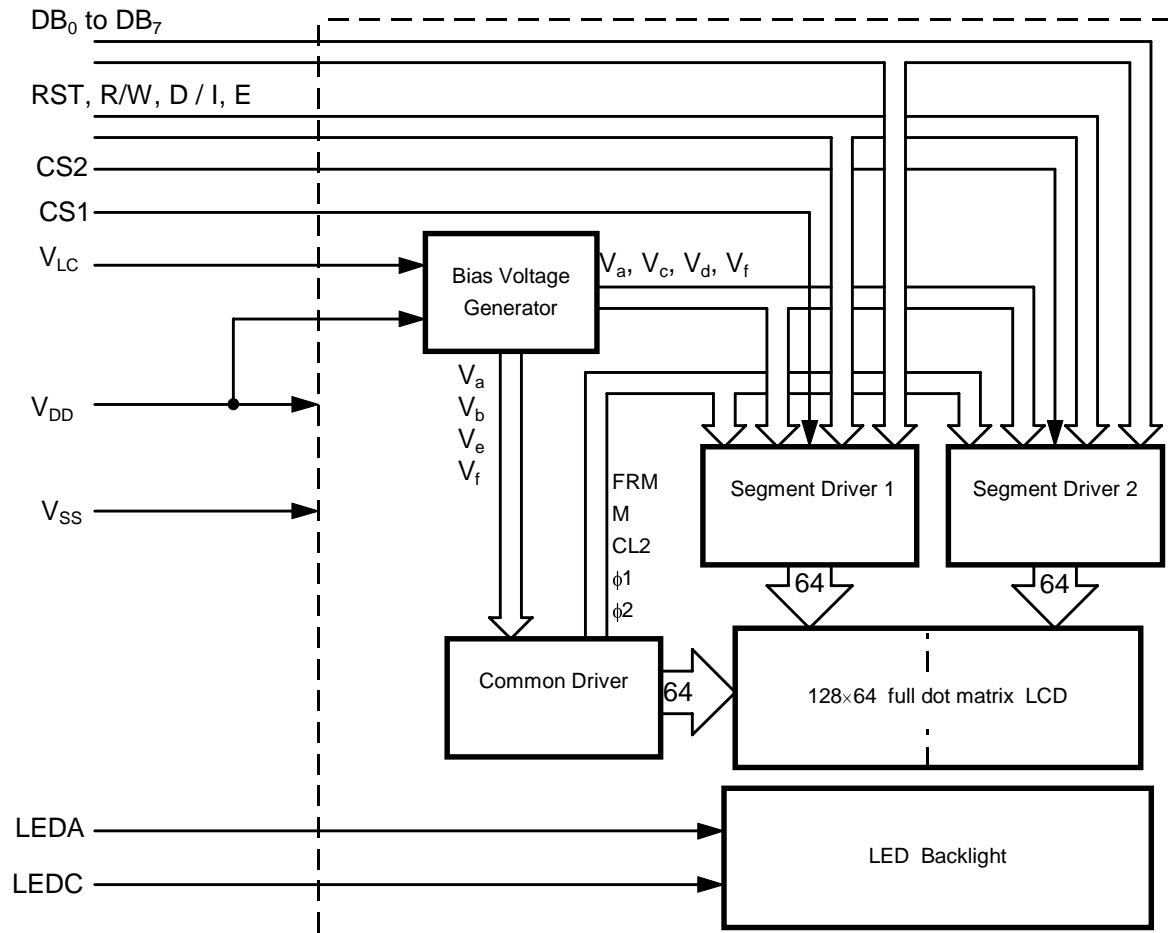

Figure 2 Block Diagram

### 2.2 Segment Drivers (HD61202)

The segment driver is a 64 drive output CMOS IC. The G1216 is driven with the panel divided into two right and left displays. A segment driver controls the divided screen. 8 bits of data transmitted from the MPU are saved in the internal display RAM, and the segment signal is generated to drive the LC. 1 bit of display RAM data corresponds to 1 dot lighting or non-lighting on the LC panel.

2.2.1 Block Diagram (Segment Driver)

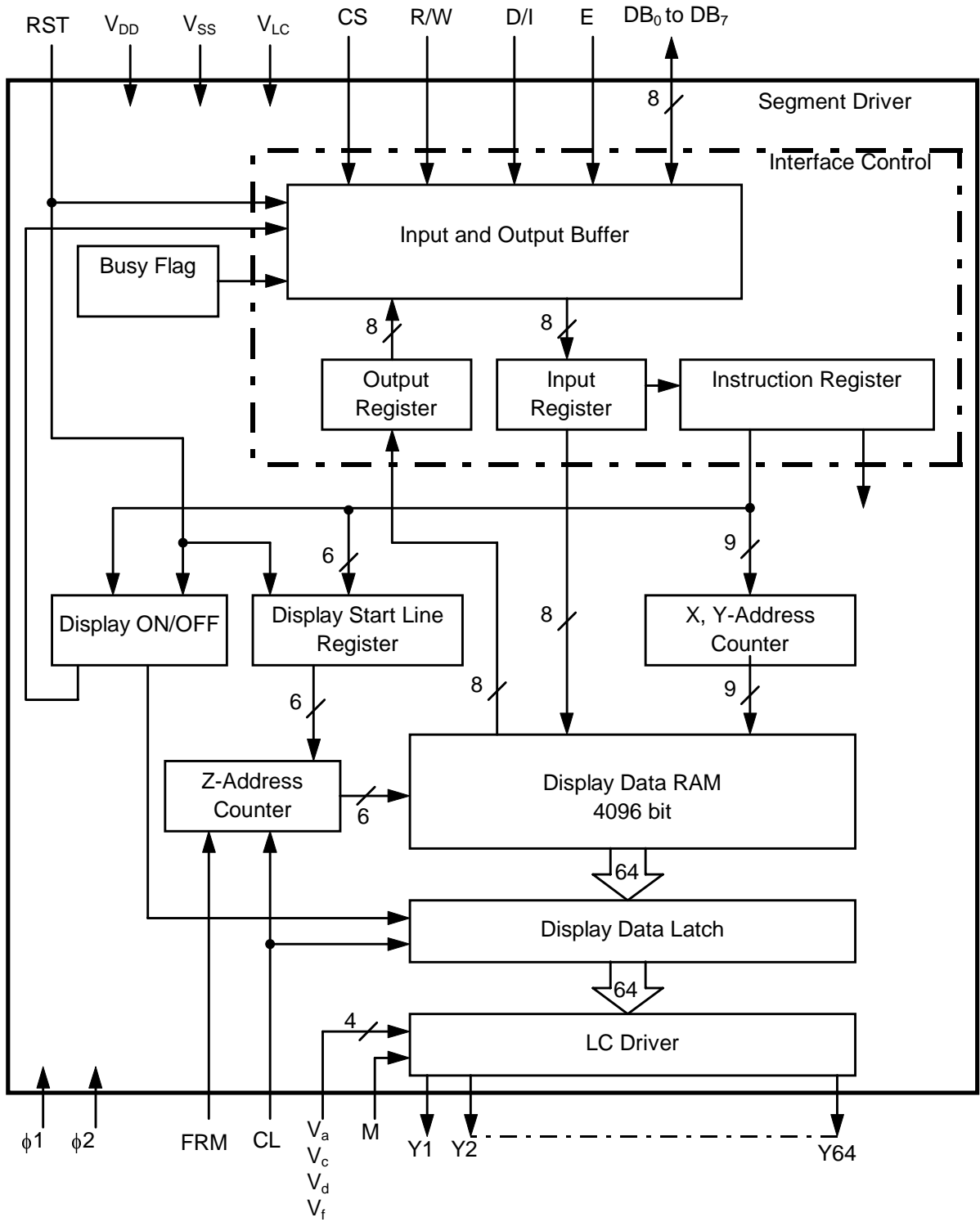

Figure 3 Segment Driver

## 2.2.2 Functions and Operations of Main Blocks

### (1) Interface Control Unit

The interface control unit consists of the following blocks:

- ① Input and output buffer
- ② Input and output register
- ③ Instruction register

The above blocks are selected according to the following combinations of R/W and D/I signals:

D / I	R / W	Functions
1	1	Output Register Read Internal Operation (Display Data RAM → Output Register)
1	0	Input Register Write Internal Operation (Input Register → Display Data RAM)
0	1	Busy Check and Status Read
0	0	Instruction

#### ① Input and output buffer

The data is transmitted through eight data buses (DB<sub>0</sub> to DB<sub>7</sub>).

DB<sub>7</sub> ..... MSB (most significant bit)

DB<sub>0</sub> ..... LSB (least significant bit)

The data can be input and output only when the Chip Select is selected. Therefore, if the Chip Select is not selected, the internal condition remains unchanged and instruction will not be executed, even when changing the signal of the input terminals excluding the RST (reset) terminal.

Note that the RST operates regardless of CS1 and CS2.

#### ② Input and output register

This product is provided with an input register and an output register so that the product can interface with MPUs having speed differing from the internal operation.

##### ● Input register

The input register is a register that is used for temporarily storing the data to be written in the display data RAM. The data to be written from the MPU to the input register will be automatically written in the display data RAM through internal operation.

When the Chip Select is selected and R / W = 0, D / I = 0, the data is written in the register, synchronized with the fall of signal E.

##### ● Output register

The output register is a register that is used for temporarily storing the data to be read from the display data RAM.

In order to read the content of the output register, the Chip Select must be selected, D/I must be 1, and R/W must be 1. When executing the "Read" instruction, the contents of the output register stored at that time are output during the time that "E" is 1. When "E" falls, display data of the currently indicated address is written in the output register. After that, the address advances by one.

The contents of the output register are rewritten by the Read instruction. The data is retained by the address set or other instructions. Accordingly, when performing the address set, and next executing the Read instruction, the data of the specified address is not output and the data of the address which is specified is output at the second data read time. Therefore, when setting the address, a dummy read is needed once. See Figure 4.

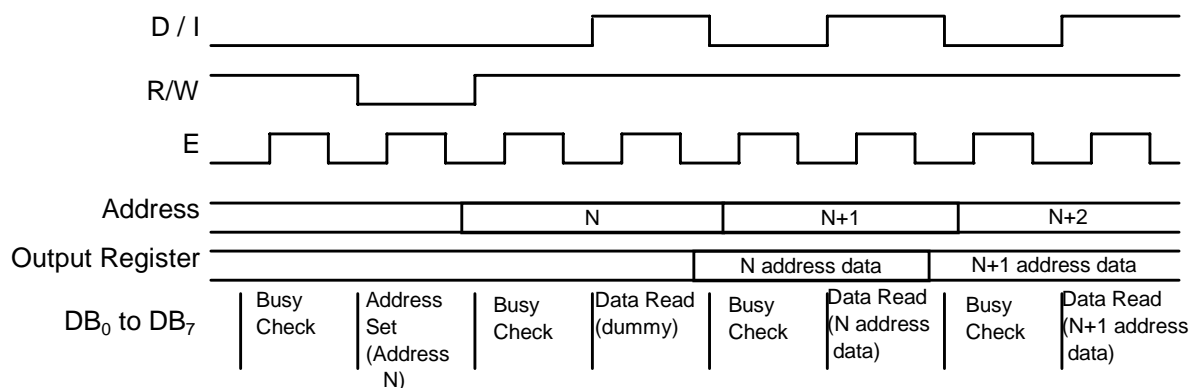
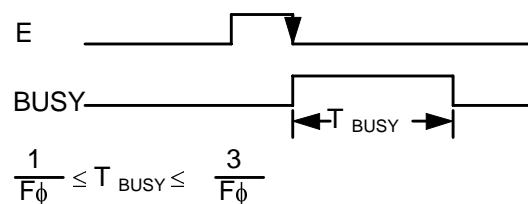

Figure 4 Read Timing

## (2) Busy flag

The status when busy flag is "1" means that the module is operating internally. Instructions other than the Status Read are not available at this time. The busy flag is output to DB<sub>7</sub> by the Status Read instruction. Ensure that the busy flag is "0" before executing the instruction.



$F_{\phi}$  is frequency of  $\phi_1$  or  $\phi_2$  (1 / 2 the source oscillation frequency of HD61203): 215 kHz typ.

Figure 5 Busy Flag

## (3) Display ON/OFF Flip/Flop

The display ON/OFF Flip/Flop is a flip-flop function that determines whether the display data corresponding to the RAM data is output to the segment on the LCD (ON status) or goes to all nonlit status regardless of the RAM data (OFF status). This is controlled by the display ON/OFF instruction. When the RST signal becomes "0," the display goes to OFF status. This flip-flop status is output to DB<sub>5</sub> by the Status Read instruction.

Even when performing display ON/OFF, the data inside the RAM is not affected.

(4) Display start line register

The display start line register is a register which determines the line address (see Figure 6) for which data is displayed on the top line of the LCD screen when displaying the contents of the display data RAM on the LCD screen. It is also used to scroll the display. The 6 bit (0 to 63) display start line information is written in this register by the Display Start Line Set Instruction.

The contents of this register are transmitted to address counter Z at "H" level of the FRM signal (common driver output) which indicates the display start on the screen.

(5) Z-address counter

The Z-address counter generates the address to output the display data synchronized with the common signal. This is a 6-bit counter which counts at the fall of the CL signal (common driver output). The contents of the display start line register are preset to the Z-address counter at "H" level of the FRM signal (common driver output).

(6) Display data RAM

The display data RAM is a RAM that stores the display dot data. 1 bit of RAM data corresponds to lighting (data=1) or non-lighting (data = 0) of 1 dot of the display on the LCD screen. Figure 6 shows the relationship between the address and data inside the RAM on either the right or left screen (64×64 dots). In this case, the display start line is 0.

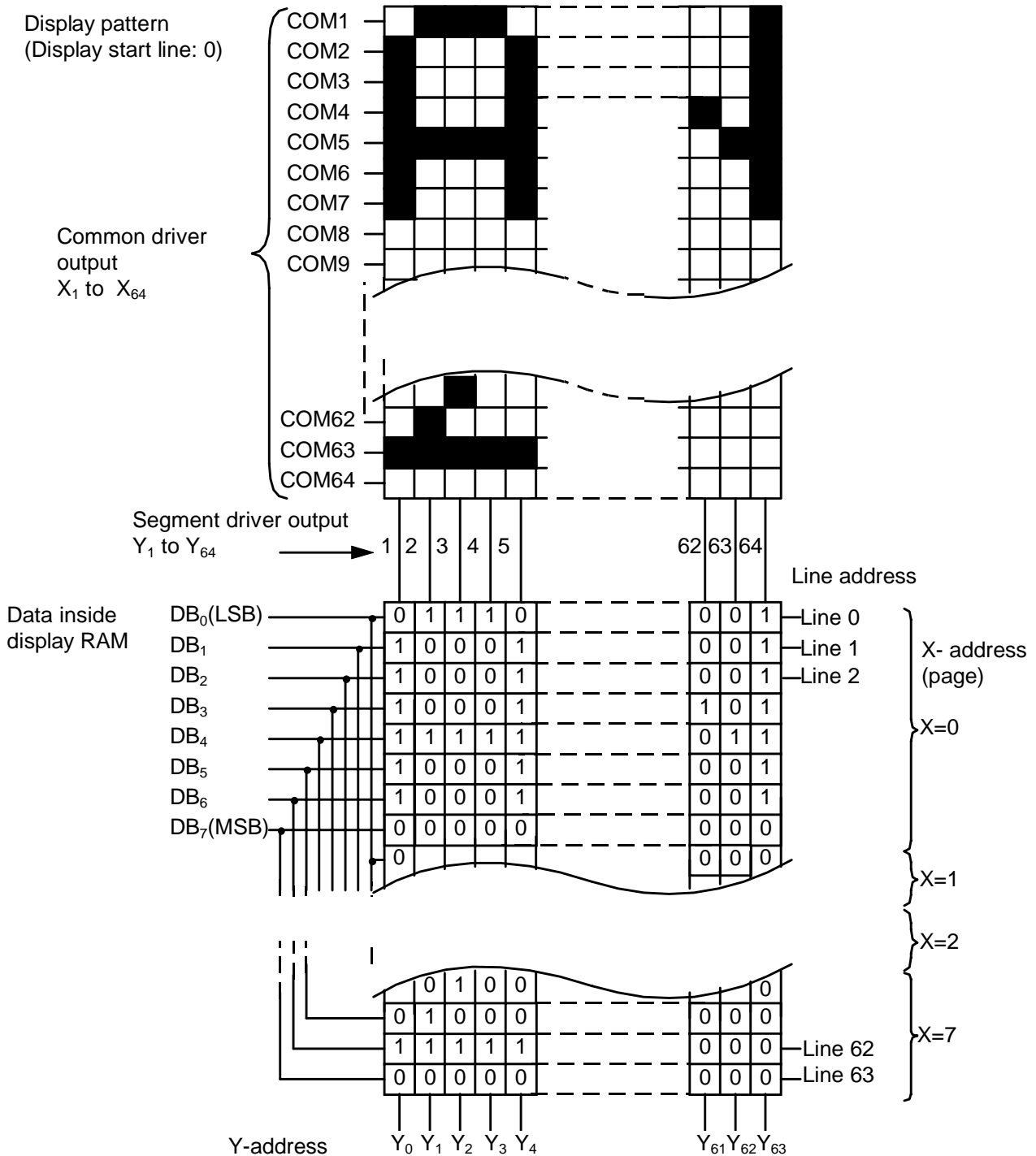

Figure 6 Relationship Between Display and Data Inside Display RAM

(7) X, Y- address counter

X, Y-address counter is a 9-bit counter which gives the address of the internal display data RAM. It is necessary to set the X-address counter of the three upper bits, and the Y-address counter of the six lower bits using differing instructions.

● X-address counter

Address counter X is a simple register that is not provided with a count function. The address is set by instruction.

- Y-address counter

This counter sets the address by instruction and is automatically advanced by the read/write operation. Counting is performed by looping the values 0 to 63.

### 2.3 Common driver (HD61203)

The common driver is a 64 drive output CMOS IC. Incorporating an oscillation circuit, this driver generates the common signal and timing signals (LC AC drive control, and one-frame timing signal) necessary for the LC display, and controls the display by supplying the timing signals to the segment drivers.

### 2.4 Bias voltage generator

Six levels of standard voltage  $V_a$  to  $V_f$  are applied to the drivers as a bias voltage. This voltage is generated by resistance division of  $V_{opr}$  and driven by a voltage follower through an operational amplifier.

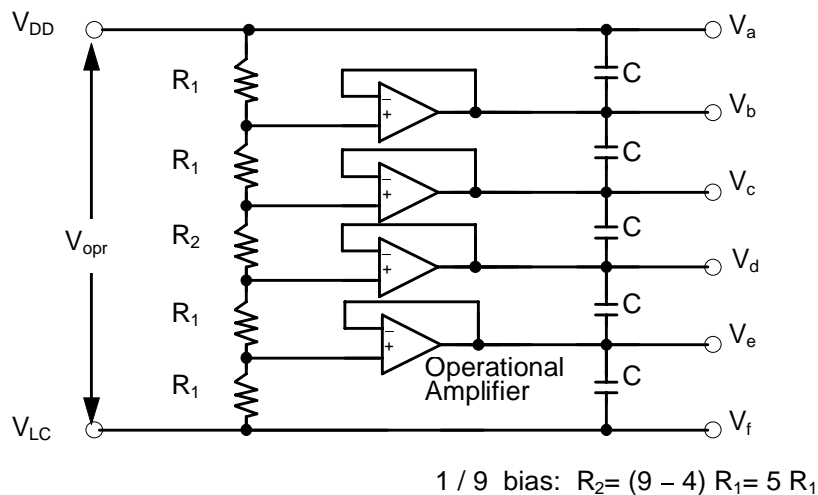

Figure 7 Bias Voltage Generator



### 3. OPERATING INSTRUCTIONS

#### 3.1 Terminal Functions

Table 1 Terminal Functions

Signal	QTY	I/O	Destination	Functions									
DB <sub>0</sub> to DB <sub>7</sub>	8	I/O	MPU	Common terminal for tristate input and output, and data bus.									
E	1	Input	MPU	Enable Write (R/W=0): Latches data of DB <sub>0</sub> to DB <sub>7</sub> at the fall of E. Read (R/W=1): Outputs data to DB <sub>0</sub> to DB <sub>7</sub> while "E" keeps a high level.									
R/W	1	Input	MPU	Read/Write selection R/W=1: When E=1 and CS1=0 or CS2=0, the data is output to DB <sub>0</sub> to DB <sub>7</sub> and read is available by MPU. R/W=0: When CS1=0 or CS2=0, DB <sub>0</sub> to DB <sub>7</sub> are ready for receiving the input.									
D/I	1	Input	MPU	Data/Instruction selection D/I=1: Indicates that the data in DB <sub>0</sub> to DB <sub>7</sub> is the display data. D/I=0: Indicates that the data in DB <sub>0</sub> to DB <sub>7</sub> is the instruction code.									
CS1, CS2	2	Input	MPU	Chip select input. Data input and output is possible under the following status:  <table border="1" style="margin-left: auto; margin-right: auto;"> <tr> <td style="text-align: center;">Terminal No.</td> <td style="text-align: center;">CS1</td> <td style="text-align: center;">CS2</td> </tr> <tr> <td style="text-align: center;">Status</td> <td style="text-align: center;">0</td> <td style="text-align: center;">0</td> </tr> </table> <div style="text-align: right; margin-right: 50px;">LCM display screen</div> <table border="1" style="margin-left: auto; margin-right: auto;"> <tr> <td style="text-align: center;">CS1</td> <td style="text-align: center;"> </td> <td style="text-align: center;">CS2</td> </tr> </table> <p>CS1: Controls the LCM left half display screen (SEG1 to SEG64). CS2: Controls the LCM right half display screen (SEG65 to SEG128).</p>	Terminal No.	CS1	CS2	Status	0	0	CS1		CS2
Terminal No.	CS1	CS2											
Status	0	0											
CS1		CS2											
RST	1	Input	MPU	Reset signal Setting the RST signal to a low level allows for initial setup. (1) ON/OFF register: 0 setup (display OFF) (2) Display start line register: 0 line setup (display starts from 0 line)  The setup status is retained until the status is changed by an instruction after reset is released.									
V <sub>DD</sub>	1	—	Power	Power terminal for logic (+5 V)									
V <sub>SS</sub>	1	—	Power	GND terminal (0 V)									
V <sub>LC</sub>	1	—	Power	Power terminal for LC drive									
LEDA	1	—	Power	LED backlight anode terminal									
LEDC	1	—	Power	LED backlight cathode terminal									
FGND	1	—	—	Frame ground <sup>1</sup>									

<sup>1</sup> FGND terminal is connected to the metallic frame of the module. Use this terminal when grounding the frame.

## 3.2 Timing Characteristics

Item	Symbol	Min.	Typ.	Max.	unit	Note
E cycle time	$t_{CYC}$	1000	–	–	ns	1, 2
E pulse width (H)	$P_{WEH}$	450	–	–	ns	1, 2
E pulse width (L)	$P_{WEL}$	450	–	–	ns	1, 2
E rise time	$t_r$	–	–	25	ns	1, 2
E fall time	$t_f$	–	–	25	ns	1, 2
Address setup time	$t_{AS}$	140	–	–	ns	1, 2
Address hold time	$t_{AH}$	10	–	–	ns	1, 2
Data setup time	$t_{DSW}$	200	–	–	ns	1
Data delay time	$t_{DDR}$	–	–	320	ns	2, 3
Data hold time during write	$t_{DHW}$	10	–	–	ns	1
Data hold time during read	$t_{DHR}$	20	–	–	ns	2

Note 1: When the MPU writes:

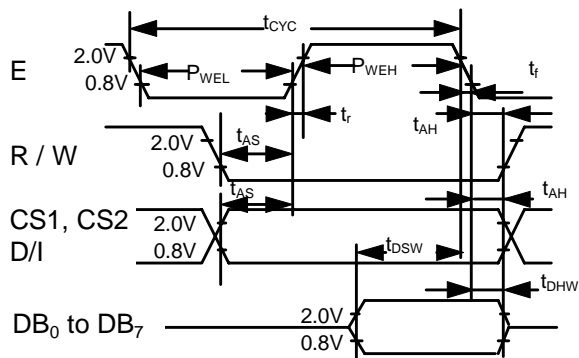

Note 2: When the MPU reads:

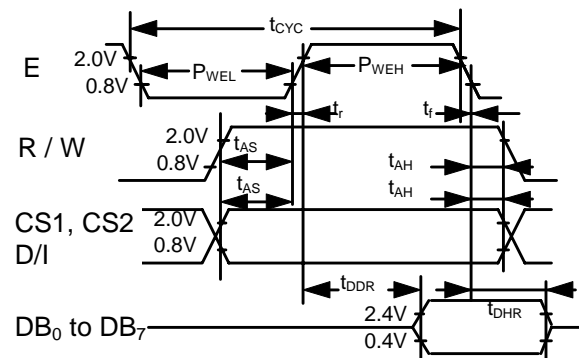
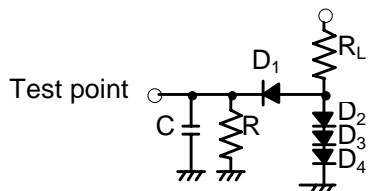
Note 3: Load circuits (DB<sub>0</sub> to DB<sub>7</sub>)

$$R_L = 2.4 \text{ k}\Omega$$

$$R = 11 \text{ k}\Omega$$

$$C = 130 \text{ pF (including jig capacity)}$$

Diodes D1 to D4 are 1S2074(H).

### 3.3 Reset Function

Setting the RST terminal to a low level when the power is on allows for initial setup.

- ① Display OFF
- ② Display start line register: Set address 0.

While the RST remains at a low level, instructions other than the status read cannot be accepted. Execute other instructions after confirming that  $DB_4=0$  (reset release) and  $DB_7=0$  (ready), using the status read instruction.

The power conditions for power-on initial setup are as follows:.

Item	Symbol	Min	Typ.	Max	unit
Reset time	$t_{RST}$	1.0	—	—	$\mu s$
Rise time	$t_r$	—	—	200	ns

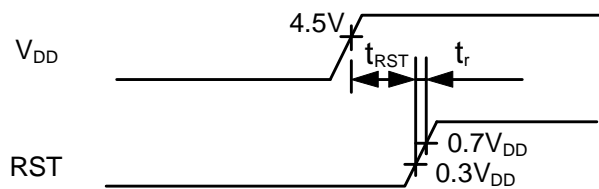

If the RESET is executed during operation, retention of the contents of all registers (excluding an ON/OFF register) and the RAM is not guaranteed. Always set them again.

### 3.4 Instructions

#### 3.4.1 General

Instructions are listed on Table 2. Instructions other than the Status Read instruction will not be executed if they are sent while another instruction is already being executed. The busy flag is “1” when executing the instruction. Check whether or not the flag is “1” before transmitting the instructions from the MPU.

Table 2 List of Instructions

	Instruction	Code										Function	
		R/W	D / I	DB <sub>7</sub>	DB <sub>6</sub>	DB <sub>5</sub>	DB <sub>4</sub>	DB <sub>3</sub>	DB <sub>2</sub>	DB <sub>1</sub>	DB <sub>0</sub>		
1	Display ON / OFF	0	0	0	0	1	1	1	1	1	1/0	Turns ON / OFF total display. Data and internal status in the display RAM remain unchanged. 1: ON 0: OFF	
2	Display start line	0	0	1	1	Display start lines ( 0 to 63 )					Determines the RAM line to be displayed on the top line (COM1) on the display.		
3	X-address (page) set	0	0	1	0	1	1	1	X-address(page) ( 0 to 7 )		Sets the X-address of the RAM (page) in the X-address (page) register.		
4	Y-address set	0	0	0	1	Y-address ( 0 to 63 )					Set Y-address of the RAM in the Y-address counter.		
5	Status read	1	0	B U S Y	0	O N / O F F	R E S E T	0	0	0	0	Reads the status. RESET 1: Reset 0: Normal ON/OFF 1: Display OFF 0: Display ON BUSY 1: during internal operation 0: READY status	
6	Display data write	0	1	Write Data								Writes data DB <sub>0</sub> (LSB) to DB <sub>7</sub> (MSB) on the data bus into the display RAM.	Accesses the RAM in which address has been specified beforehand. After that the Y-address advances by one.
7	Display data read	1	1	Read Data								Reads data DB <sub>0</sub> (LSB) to DB <sub>7</sub> (MSB) from the display RAM into the data bus.	

Note: The BUSY time varies depending upon the frequency  $F\phi$  (:215 kHz (typ.)) of  $\phi 1, \phi 2$  ( $1/F\phi \leq T_{BUSY} \leq 3/F\phi$ ).

#### 3.4.2 Detailed explanation

##### (1) Display ON/OFF

R/W	D/I	DB <sub>7</sub>	_____							DB <sub>0</sub>
Code	0	0	0	0	1	1	1	1	1	D

Turns the display ON when D=1, and OFF when D=0. When the display is turned OFF by D=0, the original display appears if D is set to 1 because the display data is retained in the display data RAM.

(2) Display start line

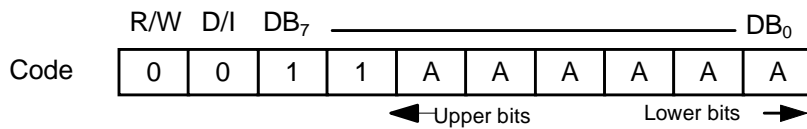

Sets the display data RAM line address expressed with binary AAAAAA in the display start line register. When displaying the content of the display data RAM, the display data on the line addresses which are set in the register is displayed on the top line on the LCD screen. For address configuration inside the display data, refer to Figure 6. Figure 8 shows display examples of start lines 0 to 3.

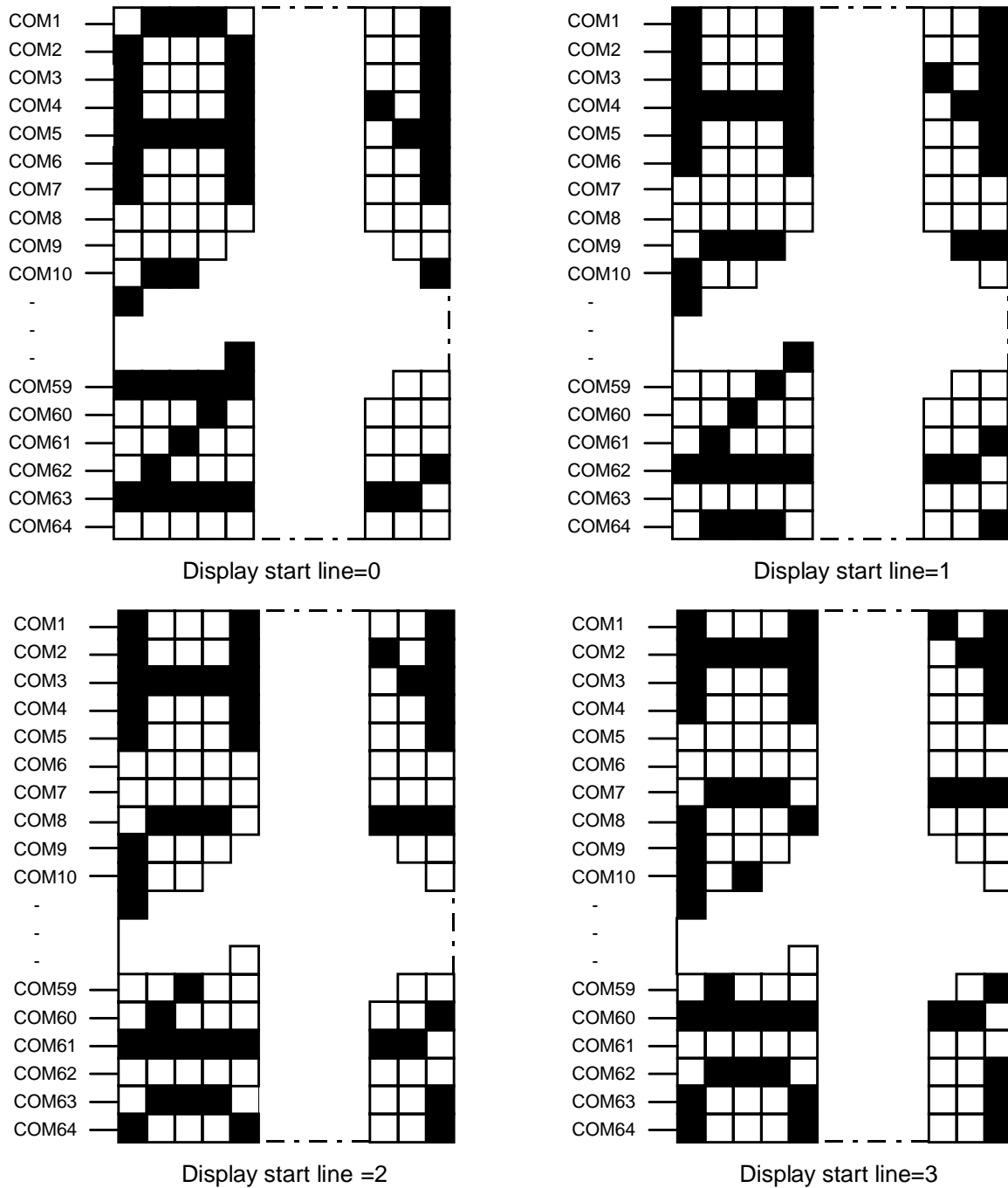
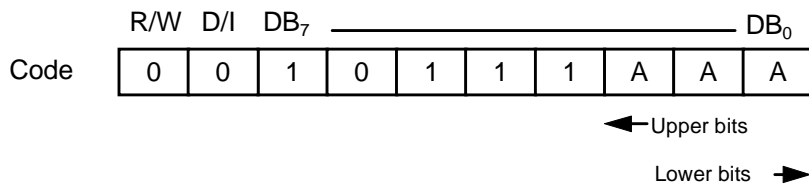
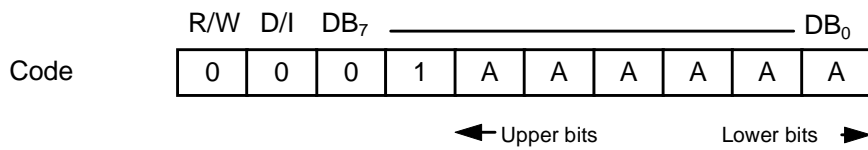

Figure 8 Relationship Between Display Start Lines and Displays

(3) X-address (page) set



The display data RAM “X” address (page) which is expressed with binary AAA is set in the X-address register. Following write/read operations from the MPU are performed on the specified X-address (page) until the next X-address (page) set is performed. The configuration of display data RAM and X-address is shown in Figure 9.



(4) Y-address set

The display data RAM Y- address which is expressed with binary AAAAAA is set in the Y-address counter. After that the Y-address counter advances by one each time write/read is performed from the MPU. The configuration of the display data RAM and Y-address is shown in Figure 9.

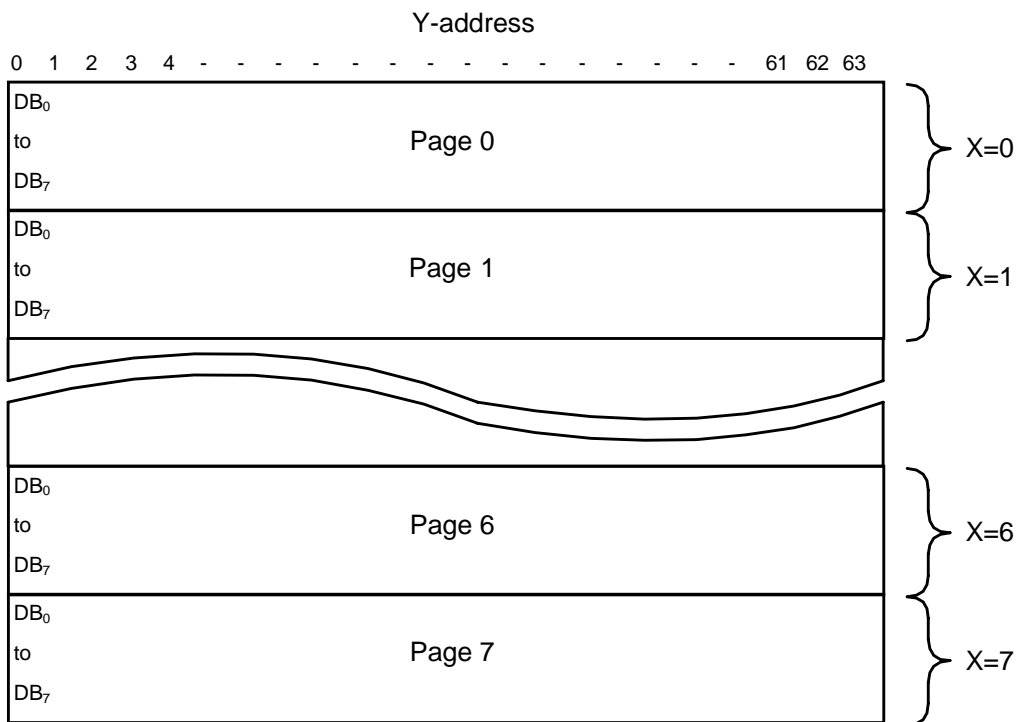
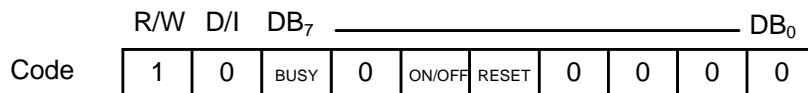

Figure 9 Display Data RAM Address Configuration

## (5) Status read



**BUSY:** When BUSY=1, it means that the the module is operating internally and the next instruction is not accepted until BUSY=0. After confirming that BUSY=0, it is necessary to perform the next write.

**ON/OFF:** Indicates that the display is OFF when ON/OFF=1.  
Indicates that the display is ON when ON/OFF=0.

**RESET:** Indicates that initial setup is performed by the RST signal.  
Indicates that the initialization is being performed when RESET=1 and instructions other than the Status Read instruction are not accepted.  
When RESET=0, initialization is completed and operation status is normal.

## (6) Display data write

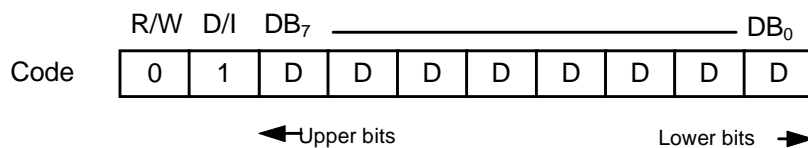

Writes 8-bit binary data DDDDDDDD in the display data RAM. After the write is completed, the Y-address is automatically advanced by one

## (7) Display data read

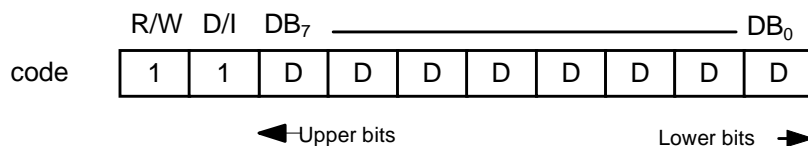

Read 8-bit binary data DDDDDDDD from the display data RAM. After read is performed, the Y-address is automatically advanced by one. A dummy read is necessary once, immediately after the address set is completed. For details, refer to segment driver output register section.

3.5 Contrast Adjustment and Power Supply Example

The LC panel viewing angle and display screen contrast are greatly affected by the ambient temperature. The recommended LC drive voltage ( $V_{opr}$ ) at each temperature is given below.  $V_{opr}$  is a value at which the best display is visually obtained. This value does not always correspond to the value at which the best contrast ( $C_{max.}$ ) is obtained. A contrast adjustment circuit example is shown below:

Temperature (°C)	-20	0	25	50	70	$V_{opr} = V_{DD} - V_{LC}$
Voltage ( $V_{opr}$ )	13.5	13.0	12.5	11.5	10.5	

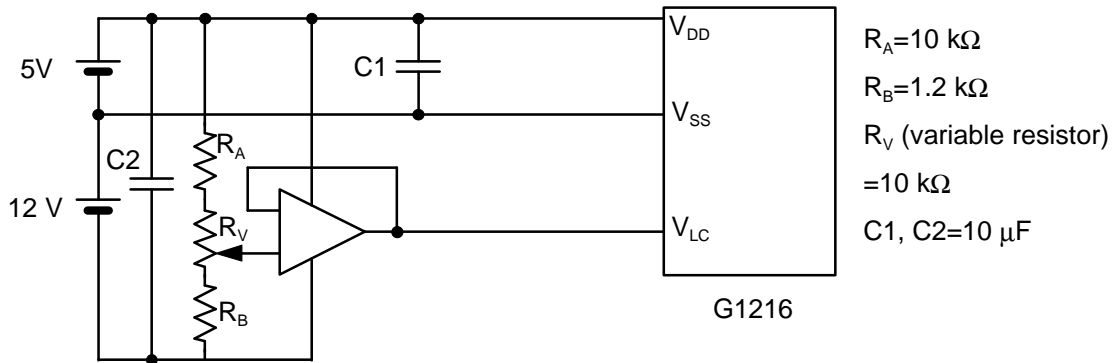

Figure 10 Contrast Adjustment

3.6 LED Backlight Driver Examples

(1) Example 1

A basic LED backlight driver example is shown in Figure 11.

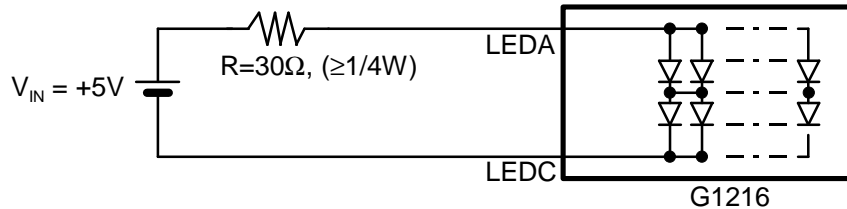

Figure 11 LED Backlight Driver Example 1

Where resistance “R” is the limit resistance of the LED forward current. The forward current depends upon the temperature. Especially, it must be decreased at high temperature. For temperature dependence, refer to forward current reduction characteristics described in 1.8 (1). The operating temperature for the G1216 ranges from -20°C to +70°C. It is necessary to determine limit resistance “R” so that the forward current becomes 50 mA or lower at +70°C.

Forward voltage  $V_F$  at each temperature of the LED backlight is shown in Table 3.

Table 3 Forward Voltage At Temperatures

Temperature ( $T_a$ )	Conditions	$V_F$ min.	$V_F$ typ.	$V_F$ max.
-20°C	$I_F=90$ mA	3.9 V	4.3 V	4.6 V
+25°C	$I_F=90$ mA	3.8 V	4.1 V	4.4 V
+70°C	$I_F=50$ mA	3.5 V	3.7 V	3.9 V



Limit resistance "R" is calculated using the following equation. The resistance becomes the value shown in Figure 11.

$$R = \frac{V_{IN} - V_F}{I_F} \quad (\Omega)$$

$V_{IN}$  =Input voltage (power voltage)(V)  
 $V_F$  =LED forward voltage (V)  
 $I_F$  =Allowable LED forward current (A)

For this resistance value, the forward current becomes lower than 50 mA at 25°C. The surface brightness of the LED backlight varies with the forward current. See Figure 12. Compared with 1.8 (4) brightness ( $I_F=90$  mA), the brightness is about 40%.

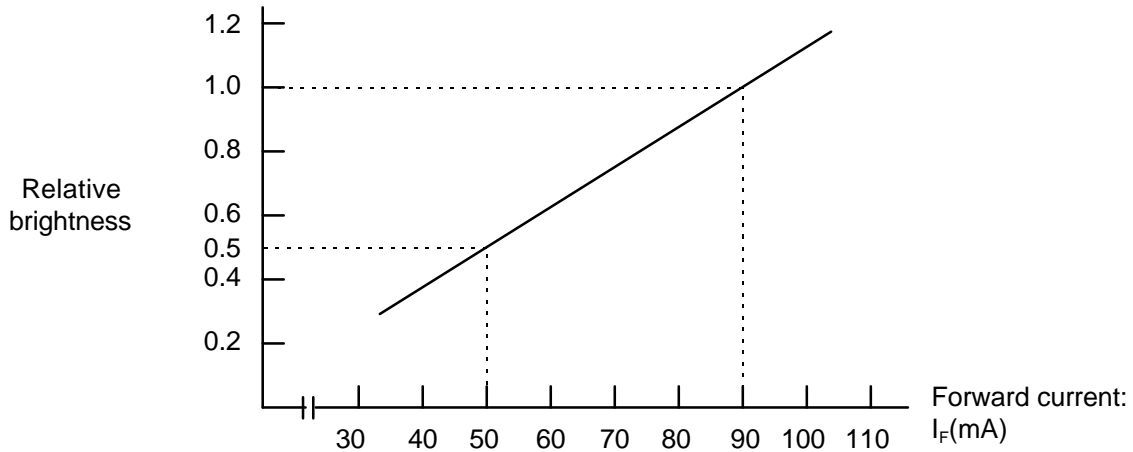

Figure 12 Forward Current-Brightness Characteristics ( $T_a=25^\circ\text{C}$ )

(2) Example 2

When you want to keep the brightness (2 nit) at 25°C, use a thermosensitive element, like a thermistor, and a transistor as shown in Figure 13. Set the thermosensitive element to about  $I_F=90$  mA at 25°C and configure it so that "IF" will be reduced as the temperature rises.

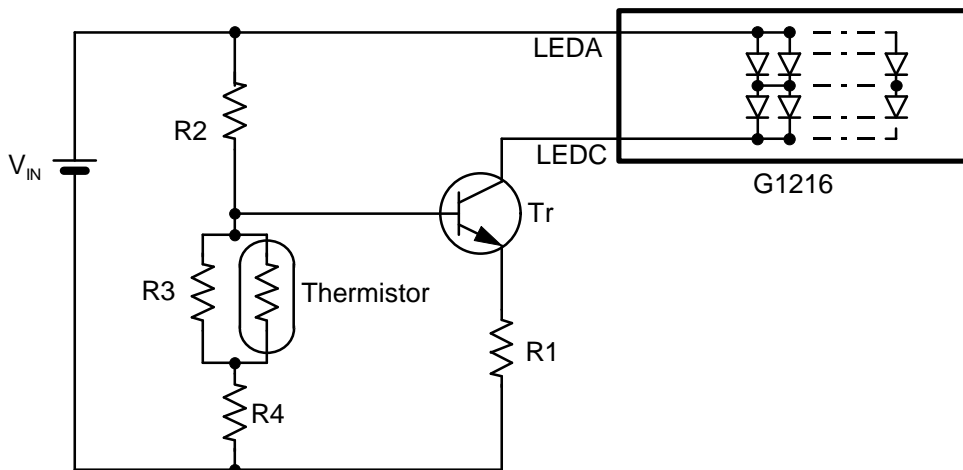

Figure 13 LED Backlight Driver Example 2

3.7 MPU Connection Diagram

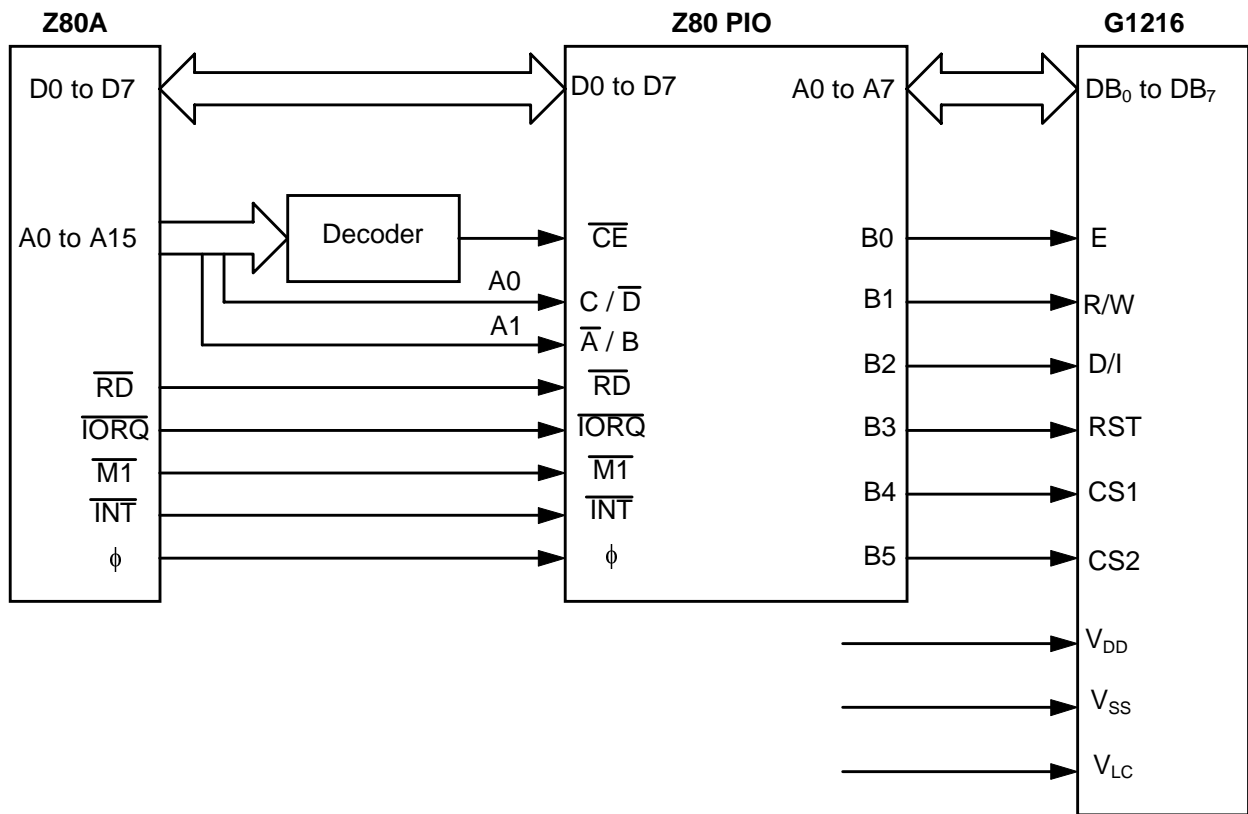

Figure 14 Example of Connection to Z80A

## 4. PRECAUTIONS

### Safety

- If the LCD panel is damaged, be careful not to get the liquid crystal in your mouth. If the liquid crystal touches your skin or clothes, promptly wash it off using soap and plenty of water.

### Handling

- Avoid static electricity, as it will damage the CMOS LSI.
- The LCD panel is made of plate glass. Do not hit or crush it.
- Do not remove the panel or frame from the module.
- The polarizer of the display is very fragile. Handle it very carefully.

### Mounting and design

- Mount the module by using the specified mounting parts and holes.
- To protect the module against external pressure, place a transparent plate (e.g., acrylic or glass) on the module, leaving a small gap between the display surface and transparent plate.

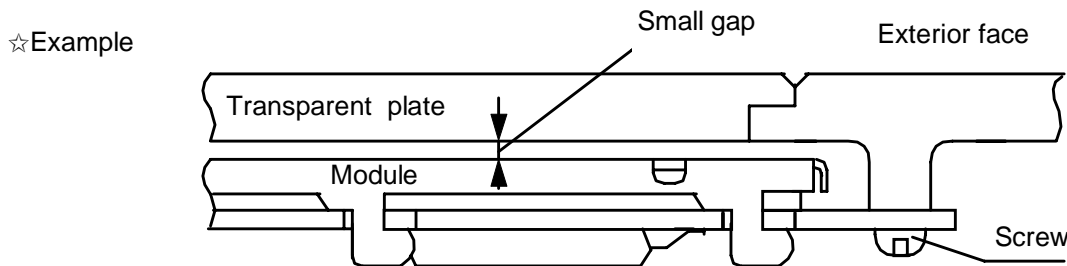

- Design the system so that no input signal is given unless the power-supply voltage is applied.
- Keep the module dry. Avoid condensation to prevent the transparent electrodes from being damaged.

### Storage

- Store the module in a dark place, where the temperature is  $25^{\circ}\text{C} \pm 10^{\circ}\text{C}$  and the relative humidity below 65%.
- Do not store the module near organic solvents or corrosive gases.
- Keep the module (including accessories) safe from vibration, shock and external pressure.

### Cleaning

- Do not wipe the polarizer with a dry cloth, as it may scratch the surface.
- Wipe the module gently with a soft cloth soaked with a petroleum benzene.
- Do not use ketonic (ketone) solvents (ketone and acetone) or aromatic solvents (toluene and xylene), as they may damage the polarizer.

## INDEX

- A -	
Active display area .....	2
- B -	
Bias voltage generator .....	7, 13
Block diagram.....	7, 8
Busy flag.....	8, 10
- C -	
Chip select.....	6, 9, 14
Cleaning .....	24
Common driver .....	7, 13
Contrast .....	3, 21
Contrast adjustment .....	21
Current consumption .....	2
- D -	
Definition of contrast.....	4
Definition of response time.....	4
Definition of viewing angles.....	3
Display data RAM.....	1, 8, 9, 11, 12, 17, 18, 19, 20
Display data read .....	17, 20
Display data write .....	17, 20
Display ON/OFF .....	8, 17
Display ON/OFF flip-flop .....	10
Display start line .....	8, 11, 12, 17, 18
Display start line register .....	8, 11
Dot dimensions.....	2
Dot pitch .....	2
- E -	
Enable .....	6, 14
- F -	
Frame frequency .....	2
- I -	
Input and output buffer .....	8, 9
Input register .....	8, 9
Input voltage .....	2, 22

- L -	
LC drive voltage .....	6, 21
LC panel life time.....	4
LED backlight characteristics .....	4
- O -	
Operating temperature .....	2
Output register.....	8, 9
Output voltage .....	2
-P -	
Power supply example .....	21
Power supply voltage .....	2, 6, 24
- R -	
Recommended LC drive voltage.....	21
Reset .....	6, 9, 14, 16
Response time .....	3
- S -	
Segment driver .....	7, 8
Status read .....	9, 10, 16, 17, 20
Storage.....	24
Storage humidity.....	2
Storage temperature .....	2
- T-	
Terminal functions .....	14
- V -	
Viewing angle .....	3
Viewing area.....	2
- W -	
Weight .....	2
- X -	
X-address counter .....	12
X, Y-address counter.....	8, 12
- Y -	
Y-address counter .....	12, 13
- Z -	
Z-address counter .....	8, 11
Z80A.....	23

## **Seiko Instruments Inc.**

### **Head Office**

Components Overseas Marketing & Sales Department  
1-8, Nakase, Mihama-ku, Chiba-shi, Chiba 261, Japan  
Phone: 043-211-1213 FAX: 043-211-8035

### **Seiko Instruments U.S.A. Inc.**

Electronic Components Division  
2990 W. Lomita Blvd., Torrance Calif. 90505, USA Phone: 310-517-7770 FAX: 310-517-7792

### **Seiko Instruments GmbH**

Siemensstrasse 9b, 63263 Neu-Isenburg, Germany Phone: 49-6102-297-0 FAX: 49-6102-297-222

### **Seiko Instruments (H. K.) Ltd.** Sales Division

4-5/F, Wyler Centre 2, 200 Tai Lin Pai Road, Kwai Chung, N.T., Kowloon, Hong Kong  
Phone: 852-4218611 FAX: 852-4805479

### **Seiko Instruments Taiwan Inc.**

5F-1 No. 99, SEC.2, Chung Shan N. Rd., Taipei 104, Taiwan, R.O.C.  
Phone: 886-2-563-5001 FAX: 886-2-521-9519