



## ***Owner's Manual***

---

***Model 9310***  
***Vehicular Slide Gate Operator***

DoorKing, Inc.  
120 Glasgow Avenue  
Inglewood, California 90301  
U.S.A.  
Phone: 310-645-0023  
Fax: 310-641-1586  
[www.doorking.com](http://www.doorking.com)



## **Use this manual with the following models only.**

All 9310 models with circuit board 4403-010. **IMPORTANT! The 4403 circuit board used in the model 9310 IS NOT interchangeable with the 4402 circuit board used in the earlier model 9300 operators.**

NOTE: Models 9310-081, 9310-083, 9310-085, 9310-087, 9310-089, 9310-091, 9310-093, 9310-095 and 9310-097 will have a supplemental manual (P/N 2340-065) that describes the operation and setup of the optional battery backup system available with this unit, and provides additional wiring information for this unit.

DoorKing, Inc. reserves the right to make changes in the products described in this manual without notice and without obligation of DoorKing, Inc. to notify any persons of any such revisions or changes. Additionally, DoorKing, Inc. makes no representations or warranties with respect to this manual. This manual is copyrighted, all rights reserved. No portion of this manual may be copied, reproduced, translated, or reduced to any electronic medium without prior written consent from DoorKing, Inc.

# QUICK START

- 1 Mount operator to pad using 3/8 or 1/2 sleeve anchors.  
See page 14-15.
- 2 Attach chain. Adjust chain to allow approximately 1-inch of sag per 10-feet of gate width.  
Be sure to remove the pin from the breather plug.  
See page 16-17.
- 3 Connect supply voltage as described in section 2.2. Be sure power is OFF!  
See page 22.
- 4 Connect control wiring as shown. Radio receiver connects to terminals 1-2-3. Full open input devices connect to terminals 4 and 13. Partial open input devices connect to terminals 5 and 13. Terminals 1 and 13 are the same - 24 volt common.
- 5 Connect secondary entrapment prevention devices.  
See page 24-25.
- 6 Connect in-ground loop wires to REVERSE and EXIT loop detectors as required.  
See page 26.
- 7 Set close timer ON or OFF (SW-1, switch 2) as required. If gate system does not utilize in-ground loop system or photo-cells, timer must be OFF.  
See page 34-35.
- 8 Push gate to open position. Adjust OPEN limit nut to activate open limit switch. Push gate closed. Adjust CLOSE limit nut to activate close limit switch.  
See page 36.
- 9 Turn power ON. Give gate an open command. If gate runs towards CLOSE position, turn power off. Change setting of direction switch (SW-1, switch 1) and then turn power ON. Give gate an open command. Adjust limit nuts as necessary.  
See page 36.
- 10 Adjust both open and close inherent reverse sensitivity. NOTE: Operator will assume a "soft shutdown" during sensitivity adjustments. This will require operator open input to be activated to resume normal operation.  
See page 37.

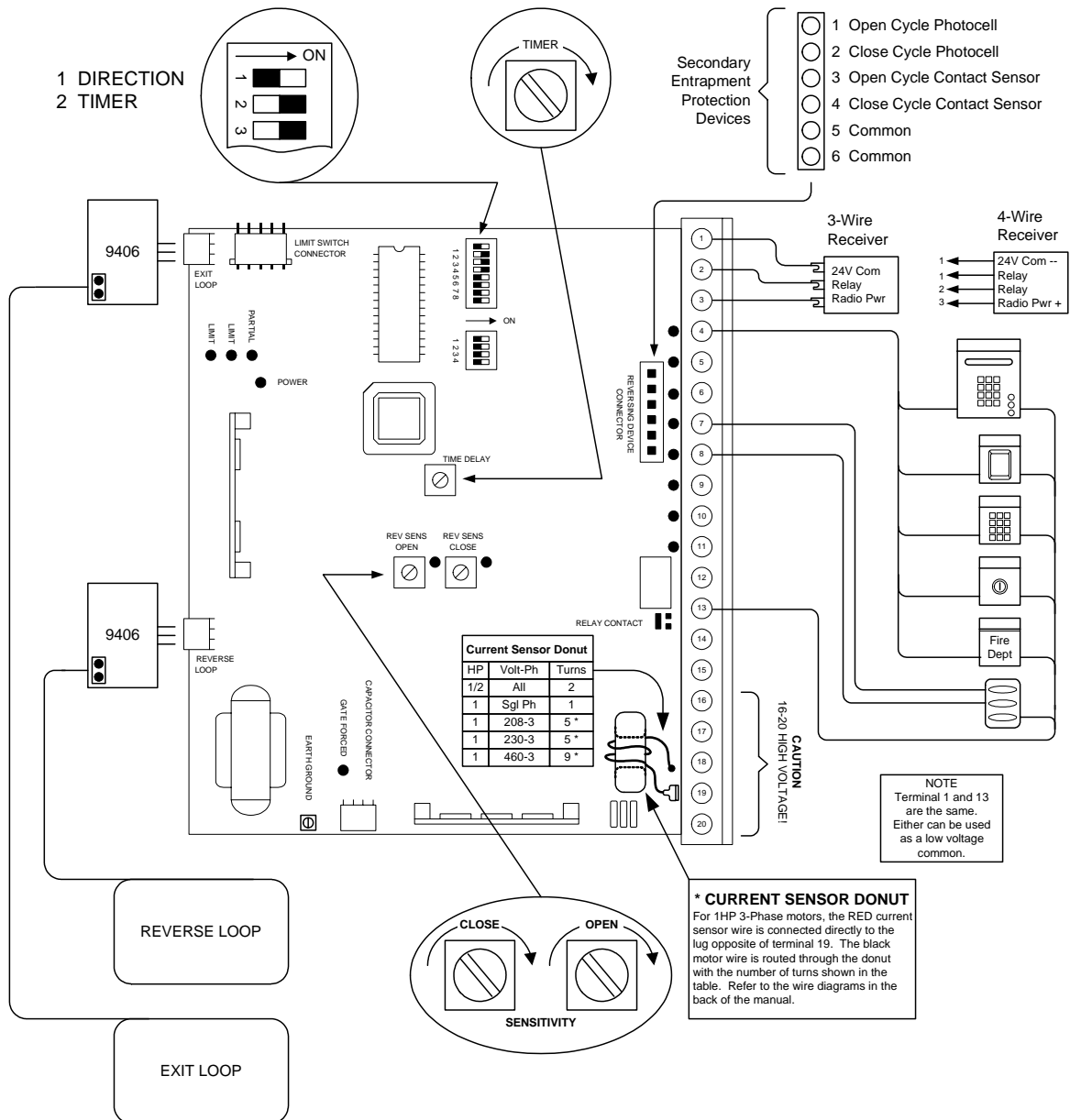

# TABLE OF CONTENTS

Important Notices.....	8
Important Safety Instructions.....	9
Restrictions and Warnings.....	10
Entrapment Prevention.....	11
Glossary .....	12

## **Section 1 – Installation**

1.1	Specifications .....	13
1.2	Concrete Pad.....	14
1.3	Operator Installation .....	15
1.4	Chain Installation .....	16
1.5	Front Mount Installation.....	17
1.6	Rear Mount Installation.....	18
1.7	Warning Sign Installation.....	19

## **Section 2 – Wiring**

2.1	Conduit Requirements.....	21
2.2	High Voltage Connections.....	22
2.3	Control Wiring.....	23
2.4	Secondary Entrapment Non-Contact Sensors .....	24
2.5	Secondary Entrapment Contact Sensors .....	25
2.6	Loop Detector Wiring.....	26
2.7	Gate Tracker™ Connections .....	27
2.8.	Alarm Reset Switch .....	28
2.9	Auxiliary Stop Input.....	28
2.10	Master / Slave Wiring Interface .....	29
2.11	Secondary Entrapment Protection for Master / Slave Configuration .....	30
2.12	Terminal Identification and Description .....	31
2.13	Secondary Device Terminal Description .....	32

## **Section 3 – Adjustments**

3.1	Circuit Board Adjustments .....	33
3.2	Switch Settings .....	34
3.3	Programming Switch Description and Function.....	35
3.4	Limit Switch Adjustment .....	36
3.5	Reverse Sensitivity Adjustment .....	37

## **Section 4 – Operating Instructions**

4.1	Power and Reset Switches .....	39
4.2	Shutdown Conditions .....	40
	Soft Shutdown .....	40
	Resetting a Soft Shutdown .....	40
	Hard Shutdown.....	41
	Resetting a Hard Shutdown .....	41
4.3	Manual / Emergency Gate Operation.....	42

## **Section 5 – Maintenance and Troubleshooting**

5.1	Maintenance Schedule.....	45
5.2	Operator Diagnostics.....	46
5.3	Trouble Shooting .....	47
	½ HP 115 VAC Wire Diagram .....	49
	½ HP 208/230/460 VAC Wire Diagram .....	50
	1 HP 115 VAC Wire Diagram .....	51
	1 HP 208/230 VAC Single Phase Wire Diagram.....	52
	1 HP 208/230/460 VAC Three Phase Wire Diagram .....	53
5.4	Accessories .....	54

## IMPORTANT NOTICES

Vehicular gate systems provide convenience to their users and limit vehicular traffic onto your property. These systems can produce high levels of force; therefore it is important that you are aware of possible hazards associated with your gate operating system. These hazards may include pinch points, entrapment, absence of controlled pedestrian access or traffic backup.

Be sure that the installer has instructed you on the proper operation of the gate and gate operator system. Be sure that the installer has trained you about the basic functions of the required reversing systems associated with your gate operating system and how to test them. These include reversing loops, inherent reversing system, electric edges, photoelectric cells, or other external devices.

- This Owner's Manual is your property. Keep it in a safe place for future reference.
- **Loops and loop detectors, photo-cells or other equivalent devices must be installed with this gate operator to prevent the gate from closing on vehicular traffic.**
- The speed limit for vehicular traffic through the gate area is 5 MPH. Install speed bumps and signs to keep vehicular traffic from speeding through the gate area. Failure to adhere to posted speed limits can result in damage to the gate, gate operator, and to the vehicle.
- Be sure that all residents are familiar with the proper use of the gate and gate operator. Be sure that all residents are familiar with the possible hazards associated with the gate system.
- Be sure that all warning signs are permanently installed on both sides of the gate in an area where they are fully visible to traffic.
- It is your responsibility to periodically check all reversing devices. If any of these devices are observed to function improperly, remove the operator from service immediately and contact your installing or servicing dealer.
- Follow the recommended maintenance schedule.
- Do not allow children to play in the area of the operator or to play with any gate-operating device.
- **Be sure that all activating devices are installed a minimum distance of 10 feet away from the gate and gate operator, or in such a way that a person cannot touch the gate or gate operator while using the activating device. If activating devices are installed in violation of these restrictions, immediately remove the gate operator from service and contact your installing dealer.**
- To remove the gate operator from service, operate the gate to the full open position and then shut off power to the operator at the service panel.

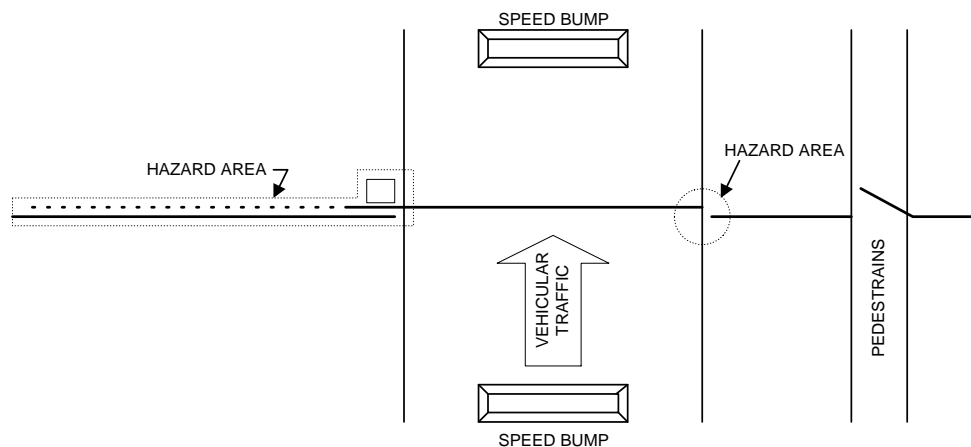



## IMPORTANT SAFETY INSTRUCTIONS

### ***WARNING - To reduce the risk of injury or death:***

1. READ AND FOLLOW ALL INSTRUCTIONS.
2. Never let children operate or play with gate controls. Keep the remote control away from children.
3. Always keep people and objects away from gate. NO ONE SHOULD CROSS THE PATH OF THE MOVING GATE.
4. Test the operator monthly. The gate MUST reverse on contact with a rigid object or stop or reverse when an object activates the non-contact sensors. After adjusting the force or the limit of travel, retest the gate operator. Failure to adjust and retest the gate operator properly can increase the risk of injury or death.
5. KEEP GATES PROPERLY MAINTAINED. Read the owner's manual. Have a qualified service person make repairs to gate hardware.
6. The entrance is for vehicles only. Pedestrians must use separate entrance.
7. SAVE THESE INSTRUCTIONS!

### ***Gate Construction***

Vehicular gates should be constructed and installed in accordance with **ASTM F2200-02; Standard Specification for Automated Vehicular Gate Construction**. For a copy of this standard, contact ASTM directly at 610-832-9585; [service@astm.org](mailto:service@astm.org); or [www.astm.org](http://www.astm.org).

## RESTRICTIONS AND WARNINGS

### *Install The Gate Operator Only If:*

- The operator is appropriate for the usage Class of the application and the gate is within the weight and length limitations specified for the operator.
- All openings of a horizontal slide gate are guarded or screened from the bottom of the gate to a minimum of 4 feet (1.2 m) above the ground to prevent a 2 ¼ inch (57.15 mm) diameter sphere from passing through the openings anywhere in the gate, and in that portion of the adjacent fence that the gate covers in the open position.
- All exposed pinch points are eliminated or guarded.
- This operator is intended for installation only on slide gates used to control vehicular traffic. Pedestrians must be provided with a separate access opening.
- The gate must be installed in a location so that sufficient clearance is provided between the gate and adjacent structures when opening and closing to reduce the risk of entrapment (see diagram). Sliding gates should not open into public access areas.
- The gate must be properly installed and work freely in both directions prior to the installation of the gate operator. Do not reduce reversing sensitivity to compensate for a damaged gate.
- Controls must be far enough from the gate so that the user is prevented from coming in contact with the gate while operating the controls. Outdoor or easily accessible controls should have a security feature to prevent unauthorized use.
- All warning signs and placards must be installed where visible in the area of the gate.

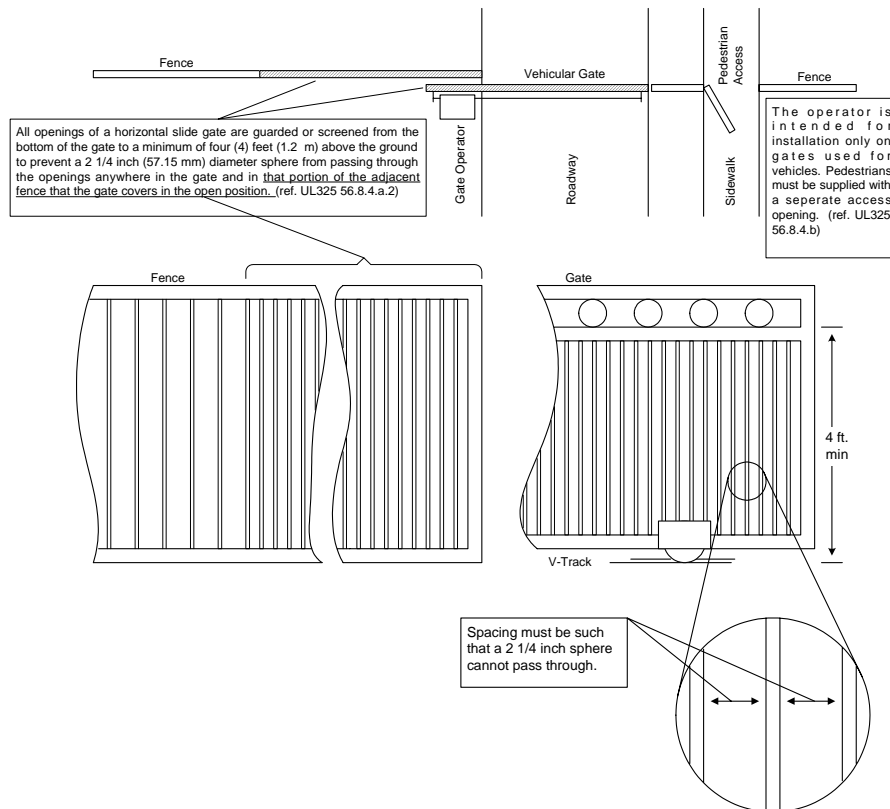

## ENTRAPMENT PREVENTION

This vehicular gate operator is equipped with an inherent (Type A) entrapment sensing system. This system will sense an obstruction in both the opening and closing gate cycles, and will cause the gate to reverse direction should an obstruction be encountered. If the system detects a second obstruction before reaching the full open or close limit after the initial reversal, an alarm will activate and the operator will require a reset before resuming normal operation. See Section 4 for more information.

### EXTERNAL ENTRAPMENT PREVENTION

Non-contact and/or contact sensors must be installed individually or in combination with each other to provide external entrapment prevention. For gate operators utilizing a non-contact sensor:

- See diagram below for placement of non-contact sensors.
- Care should be exercised to reduce the risk of nuisance tripping, such as when a vehicle trips the sensor while the gate is still moving, and
- One or more non-contact sensors shall be located where the risk of entrapment or obstruction exists, such as the perimeter reachable by a moving gate or barrier.

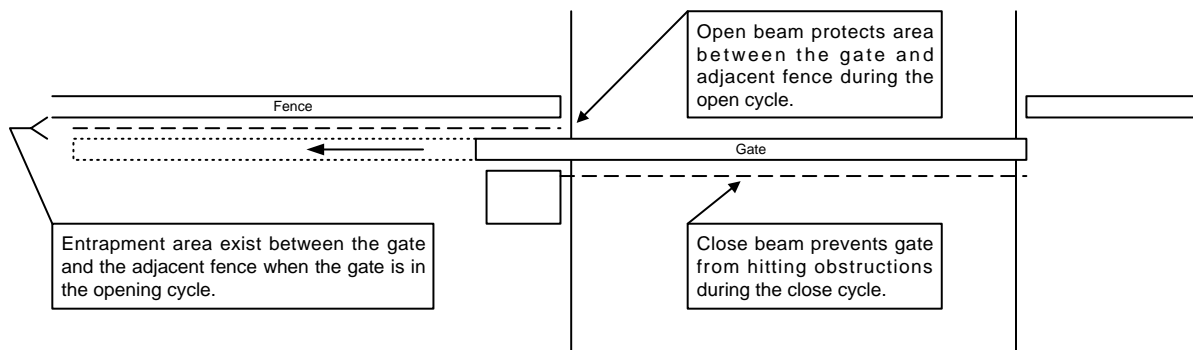

For gate operators utilizing a contact sensor:

- A hardwired contact sensor shall be located and it's wiring arranged so that the communication between the sensor and the gate operator is not subjected to mechanical damage.
- A wireless contact sensor such as one that transmits radio frequency (RF) signals to the gate operator for entrapment prevention functions shall be located where the transmission of the signals are not obstructed or impeded by building structures, natural landscaping or similar obstruction. A wireless contact sensor shall function under the intended end-use conditions.

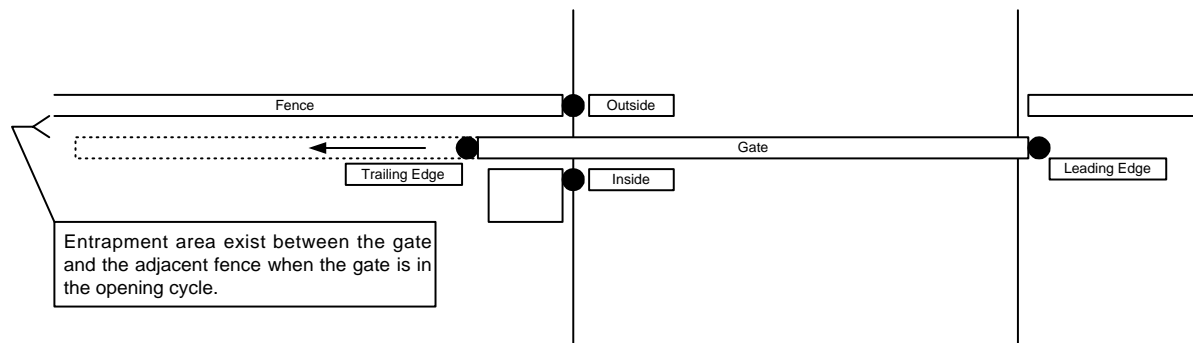

## GLOSSARY

**GATE** – A moving barrier such as a swinging, sliding, raising, lowering, or the like, barrier, that is a stand-alone passage barrier or is that portion of a wall or fence system that controls entrance and/or egress by persons or vehicles and completes the perimeter of a defined area.

**RESIDENTIAL VEHICULAR GATE OPERATOR-CLASS I** - A vehicular gate operator (or system) intended for use in a home of one-to four single family dwelling, or garage or parking area associated therewith.

**COMMERCIAL / GENERAL ACCESS VEHICULAR GATE OPERATOR-CLASS II** - A vehicular gate operator (or system) intended for use in a commercial location or building such as a multi-family housing unit (five or more single family units), hotels, garages, retail store, or other building servicing the general public.

**INDUSTRIAL / LIMITED ACCESS VEHICULAR GATE OPERATOR-CLASS III** - A vehicular gate operator (or system) intended for use in an industrial location or building such as a factory or loading dock area or other locations not intended to service the general public.

**RESTRICTED ACCESS VEHICULAR GATE OPERATOR-CLASS IV** - A vehicular gate operator (or system) intended for use in a guarded industrial location or building such as an airport security area or other restricted access locations not servicing the general public, in which unauthorized access is prevented via supervision by security personnel.

**SYSTEM** - In the context of these requirements, a system refers to a group of interacting devices intended to perform a common function.

**WIRED CONTROL** - A control implemented in a form of fixed physical interconnections between the control, the associated devices, and an operator to perform predetermined functions in response to input signals.

**WIRELESS CONTROL** - A control implemented in means other than fixed physical interconnections (such as radio waves or infrared beams) between the control, the associated devices, and an operator to perform predetermined functions in response to input signals.

**INHERENT ENTRAPMENT SENSOR SYSTEM** - An automatic sensor system, which senses entrapment of a solid object and is incorporated as a permanent and integral part of the operator.

**ENTRAPMENT** – The condition when an object is caught or held in a position that increases the risk of injury.

# SECTION 1 - INSTALLATION

Prior to beginning the installation of the slide gate operator, we suggest that you become familiar with the instructions, illustrations, and wiring guide-lines in this manual. This will help insure that your installation is performed in an efficient and professional manner.

The proper installation of the vehicular slide gate operator is an extremely important and integral part of the overall access control system. Check all local building ordinances and building codes prior to installing this operator. Be sure your installation is in compliance with local codes.

## 1.1 Specifications

Class of Operation:	Class I, II, III, IV
Type of Gate:	Vehicular Slide Gates Only
Horsepower:	1/2 HP and 1 HP
Voltage:	1/2 HP: 115, 208, 230, 460 1 HP: 115 – 230 1 <sup>Ø</sup> , 208 / 230 / 460 3 <sup>Ø</sup>
Current:	Varies with voltage and phase. See page 22.
Max Gate Weight <sup>1</sup> :	1000 Lbs. (1/2 HP) <sup>2</sup> , 1500 Lbs. (1 HP) <sup>2</sup>
Max Gate Length <sup>1</sup> :	30 Ft. (1/2 HP), 45 Ft. (1 HP)
Cycles / Hr:	60/Hr
Speed:	Approximately 1 Ft./Sec.
Entrapment Protection:	Primary – Inherent (Type A) Secondary – Provision for connection of a non-contact sensor (Type B1) and/or a contact sensor (Type B2). Secondary entrapment protection devices are not supplied with the operator and must be ordered separately.

Note 1: Assumes gate is in good working condition installed on a level surface.

Note 2: Operators with Convenience Open Option  
800 Lbs. (1/2 HP), 1300 Lbs. (1 HP)

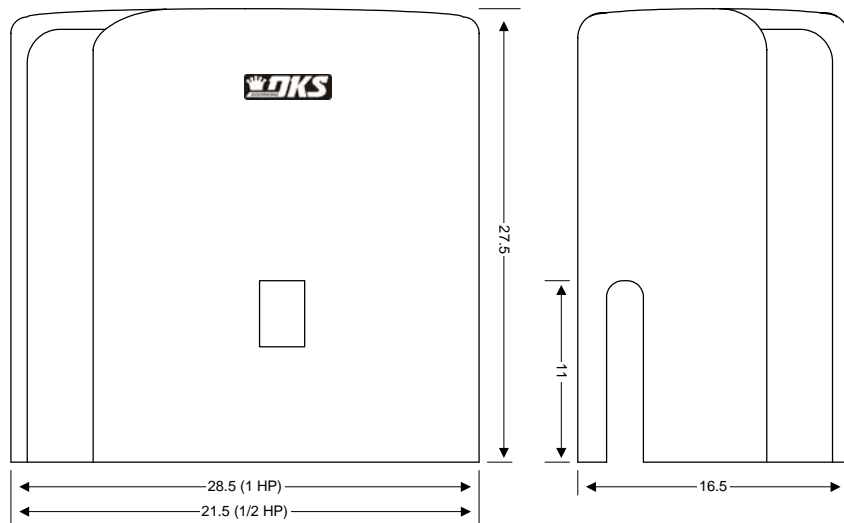

## 1.2 Concrete Pad

The model 9310 vehicular gate operator is designed to be mounted on a concrete pad.

1. Construct a form for the mounting pad according to the specifications shown below. **Note that the pad for the 1 HP operator extends an additional 6 inches to the right to accommodate the larger cover.** Be sure to level the top edge of the form and that the top of the form is a minimum of four (4) inches above ground level. We suggest that you contact the local building department to determine the required depth of the pad since soil conditions and code requirements vary from city to city.
2. Set conduits, reinforcing bars and/or wire mesh if required. **If the slide gate operator has a battery backup system, then conduits must be located in the area shown.** The number of conduits is determined by the application requirements. We suggest using a minimum of four (4) conduits. 1-High voltage power lines; 2-Low voltage control lines; 3-Loop lead-in wires (open loop); 4-Loop lead-in wires (reverse loops). **See SECTION 2.**
3. Mix the concrete according to the manufacturers instructions. Pour the mixture into the form and tamp. Level and finish the surface after pouring is complete. Do not set anchor bolts in the concrete. Sleeve anchors should be used to secure the operator to the pad. This allows greater flexibility in positioning the operator on the pad.
4. Allow the pad to cure for 48 hours before removing the forms or mounting the operator.

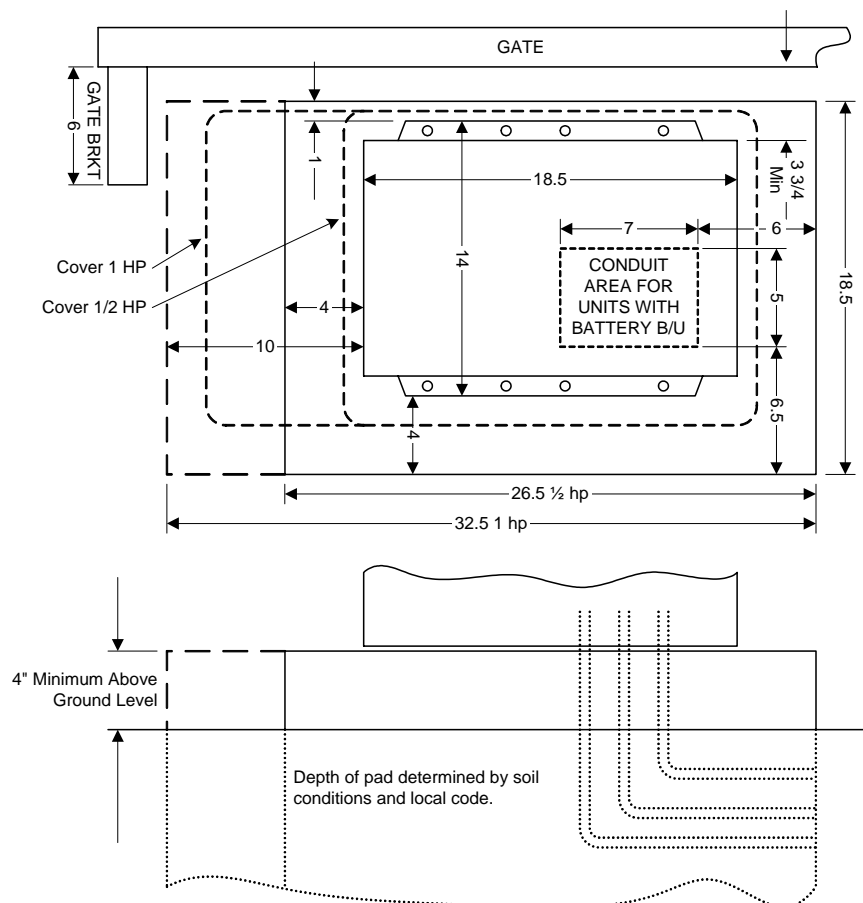

### 1.3 Operator Installation

- Position the operator on the pad so that there is a minimum clearance of one (1) inch between the back of the operator housing and the gate.
- **IMPORTANT!!** Be sure that the operator is parallel to the gate! Installing the operator in any other manner will cause excessive chain noise, chain wear and stretching, and premature idler failure.
- Mark the mounting holes on the mounting pad. Use a concrete drill bit to drill the mounting holes to the size and depth required for the anchors being used. We recommend 1/2 x 2 or 3/8 x 2 sleeve anchors (not supplied).
- After drilling the mounting holes, clean them out and install the sleeve anchors. Position the operator over the anchors and tighten.

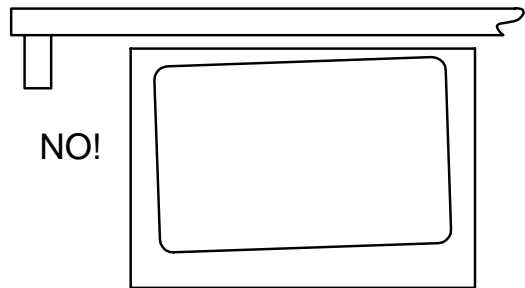
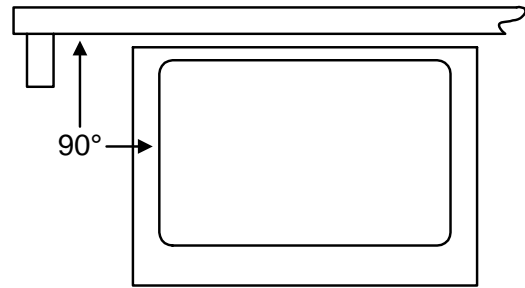

## 1.4 Chain Installation

1. Secure the chain brackets to each end of the gate so that the brackets are level with the top chain cutouts in the operator housing. Brackets should be attached to the inside of the frame so that the chain bolts, when attached, do not protrude beyond the frame of the gate.
2. **Remove the breather plug pin from the gear-box and discard it** (page 17).
3. Route the chain through the gate operator: under the chain guide idlers and over the drive sprocket.
4. Attach the chain to the chain bolts using the master links supplied, and then attach the chain bolts to the chain brackets using the hardware supplied. Make any adjustments to the chain length at this time.
5. Adjust the chain bolts to tighten the chain. The chain should sag no more than one (1) inch per 10 feet of travel. Do not over tighten the chain. **IMPORTANT!! Be sure that the chain is parallel to the gate. Installing the chain in any other manner will cause excessive noise, chain idler wear and chain stretching.**
6. If the operator is to be rear mounted, an endless idler assembly (P/N 2600-818) is required. Depending on the length of the gate, additional chain may also be required. See detail on page 18.

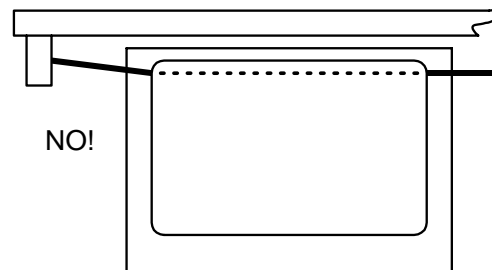
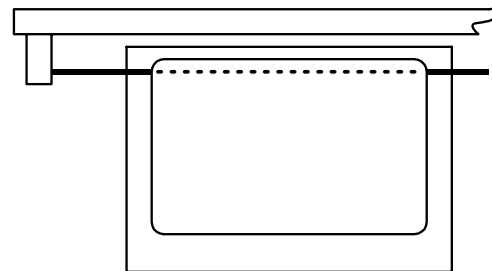
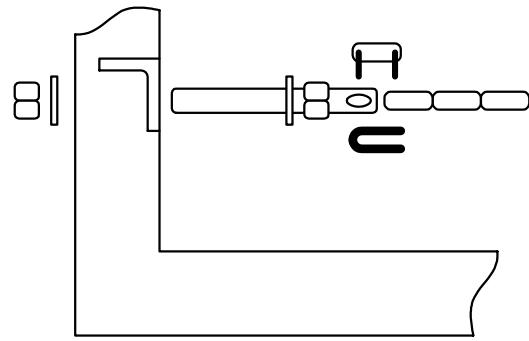



1.5 Front Mount Installation

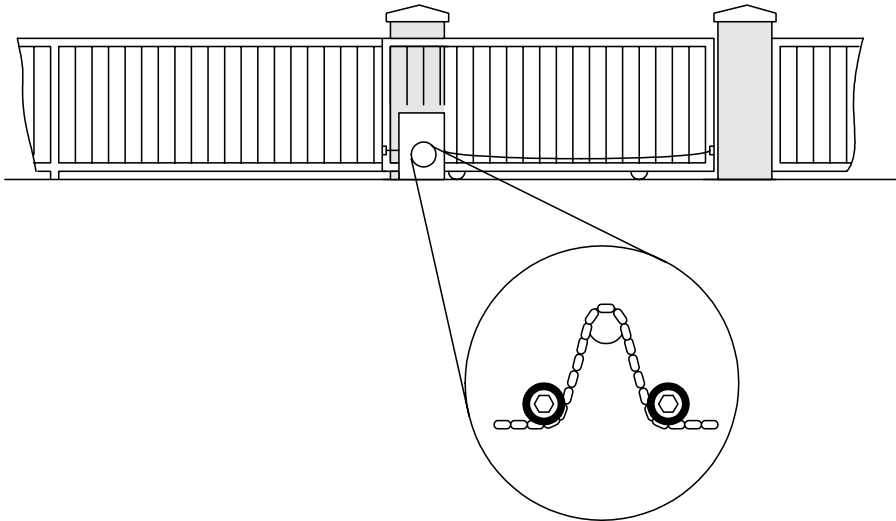
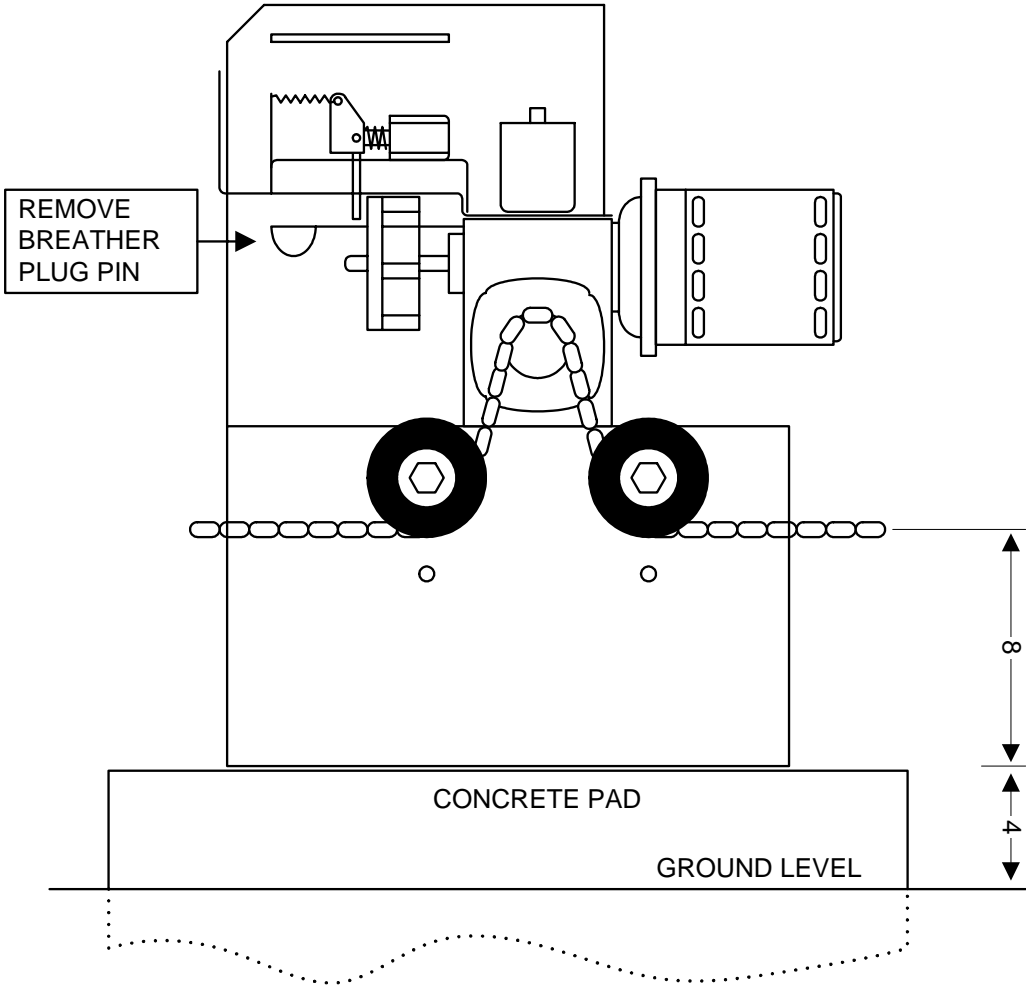

## 1.6 Rear Mount

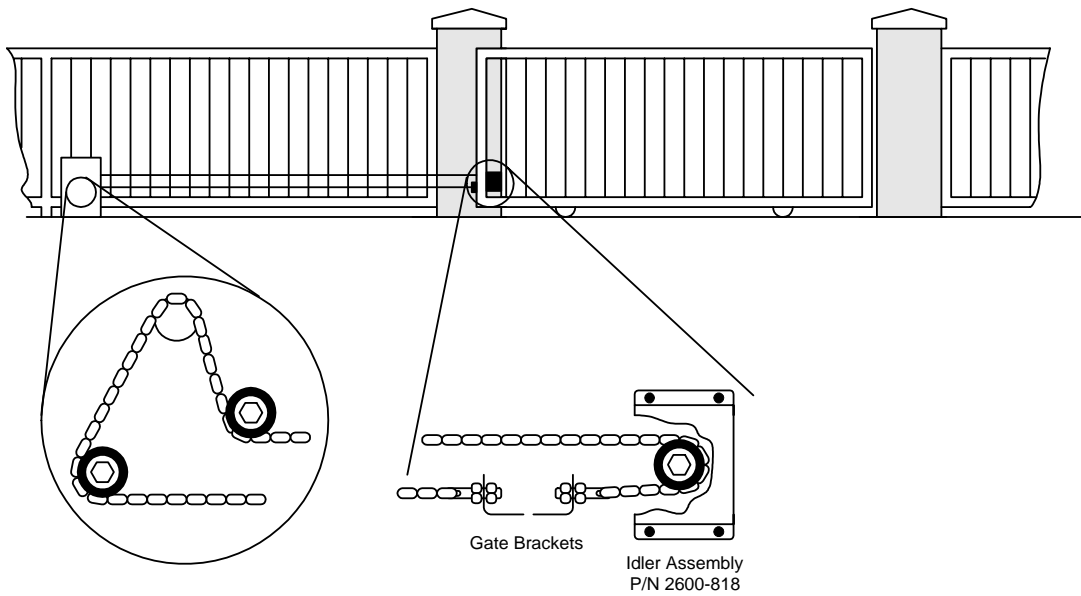
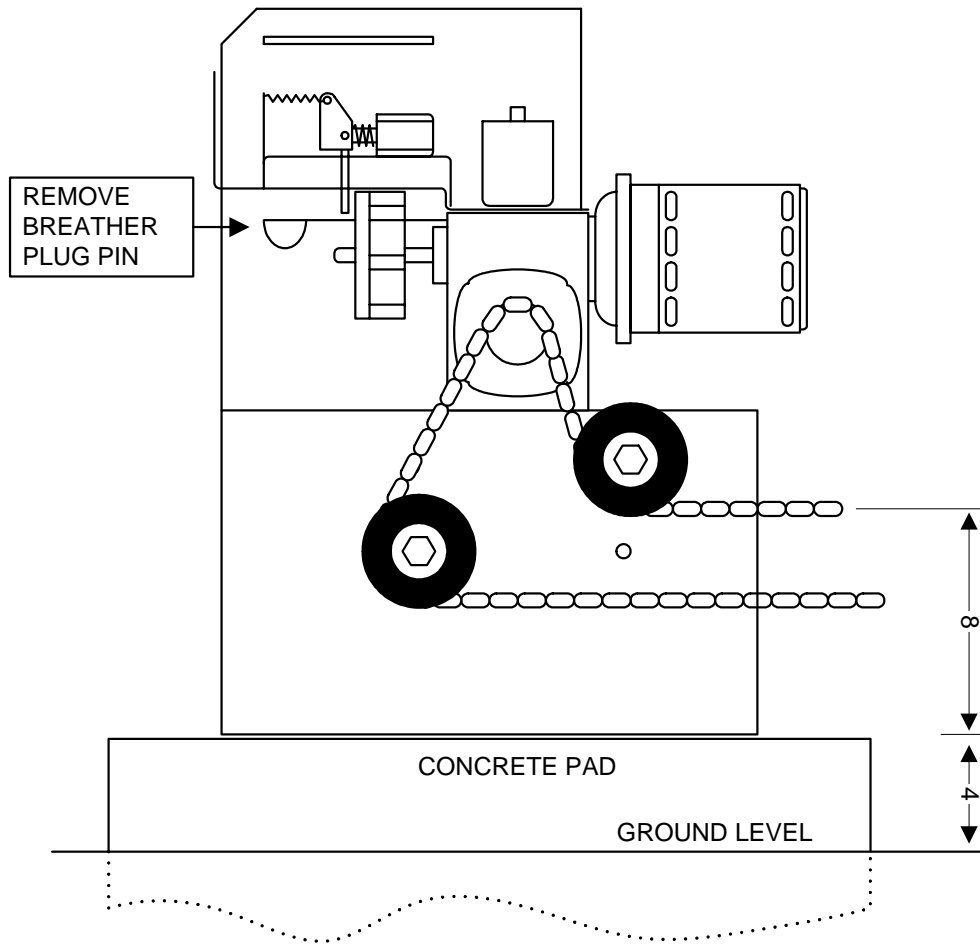

## 1.7 Warning Sign Installation

This DoorKing slide gate operator is shipped with two warning signs. The purpose of the warning signs is to alert uninformed persons, and to remind persons familiar with the system, that a potential hazard may exist so that appropriate action can be taken to avoid the hazard or to reduce exposure to the hazard.

1. Permanently install the supplied warning signs in locations so that the signs are visible by persons on both sides of the gate.
2. Use appropriate hardware such as wood or metal screws (not supplied) to install the warnings.





## SECTION 2 – WIRING

Before attempting to connect any wiring to the operator, be sure that the circuit breaker in the electrical panel is in the OFF position. **A separate power disconnect must be installed at the operator location.** Permanent wiring must be installed to the operator as required by local electrical codes. It is recommended that such work be performed by a licensed electrical contractor.

### 2.1 Conduit Requirements

Since building codes vary from city to city, we highly recommend that you check with your local building department prior to installing any permanent wiring to be sure that all wiring to the operator (both high and low voltage) complies with local code requirements.

**THIS GATE OPERATOR MUST BE PROPERLY GROUNDED!!**

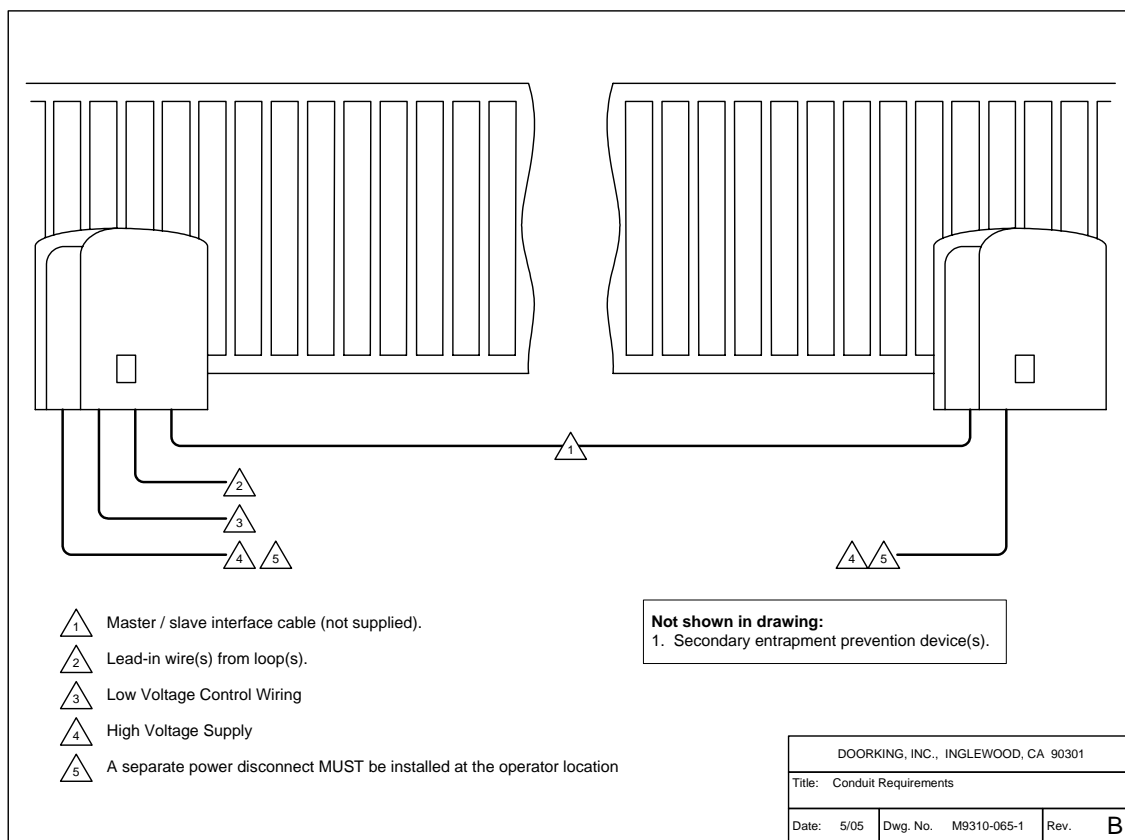

- The conduit requirements shown are for a typical slide gate operator installation (the slave operator is shown for those applications where a slave operator may be used). The conduit requirements for your application may vary from this depending on your specific needs.
- Use only sweeps for conduit bends. Do not use 90° connectors as this will make wire pulls very difficult and can cause damage to wire insulation.
- Use separate conduits for high and low voltage.
- We suggest that minimum ¾-inch conduit be used.
- Be sure that all conduits are installed in accordance with local codes.

## 2.2 High Voltage Connections

Use Table 1 to determine high voltage wire size requirements. The distance shown in the chart is measured in feet from the operator to the power source. If power wiring is greater than the maximum distance shown, it is recommended that a service feeder be installed. A separate power disconnect must be installed at the operator. The wire table is based on stranded copper wire. Wire run calculations are based on a 3% voltage drop on the power line, plus an additional 10% reduction in distance to allow for other losses in the system.

VOLTS	HP	AMPS	WIRE SIZE / DISTANCE IN FEET			
			12 AWG	10 AWG	8 AWG	6 AWG
115	1/2	5.4	170	275	460	685
208 / 230	1/2	2.7	685	1100	1830	2750
460	1/2	1.4	2875	4600	7665	11500
115	1	9.7	95	155	250	385
208 / 230 - 3 <sup>Ø</sup>	1	2.8	660	1060	1765	2650
460 - 3 <sup>Ø</sup>	1	1.3	2980	4770	8000	11940

Table 1

- Route incoming high voltage power through disconnect and into the operator.
- Be sure wiring is installed in accordance with local codes. Be sure to color code all wiring.
- Connect the power wires to the high voltage terminal strip as shown.
- It is recommended that a surge suppresser be installed on the high voltage power lines to help protect the operator and circuit board from surges and power fluctuations.
- If 3-Ph power is used to power a 1/2 HP unit, cap off one leg of the power as shown below.

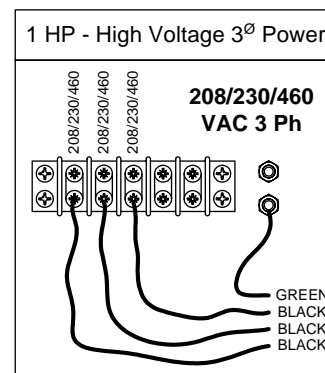
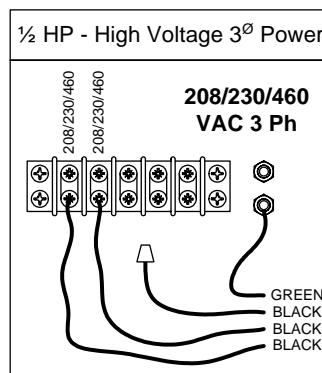
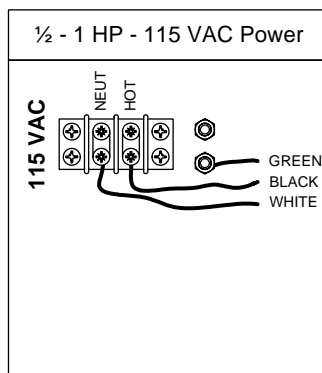
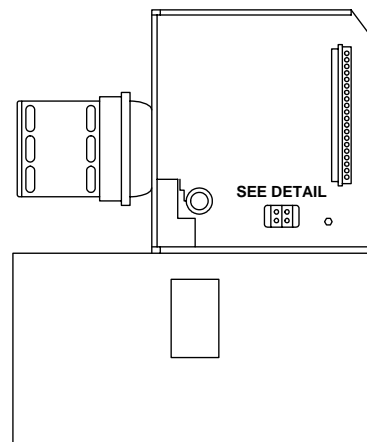

## 2.3 Control Wiring

Controls must be far enough from the gate so that the user is prevented from coming in contact with the gate while operating the controls. Outdoor or easily accessible controls should have a security feature to prevent unauthorized use.

- Connect optional control devices to the operator terminal strip as shown below. Check your connections carefully! **The 4403 circuit board has different wiring terminals than the 4402 circuit board found in the older model 9300 operator.** All inputs to the terminal strip must be NORMALLY OPEN.
- Be sure that all electrical connections are made in accordance with local electrical codes. Use 18 AWG wire for all low voltage wiring, maximum distance 3000 feet. Use a low voltage surge suppresser, DoorKing P/N 1878-010 if low voltage wire runs exceed 1000 feet.
- **Standard reversing input (term 7) only functions while the gate is in the closing cycle and should not be used as an input for a secondary entrapment prevention device. See Section 2.4 for secondary entrapment prevention device wiring.**
- Do not power any devices from the circuit board other than a low voltage radio receiver as shown. Radio power available at terminal 3 is limited to 250 ma at 24 VAC. Three-button control station must be DoorKing P/N 1200-006 or 1200-007 only. Others will not work.

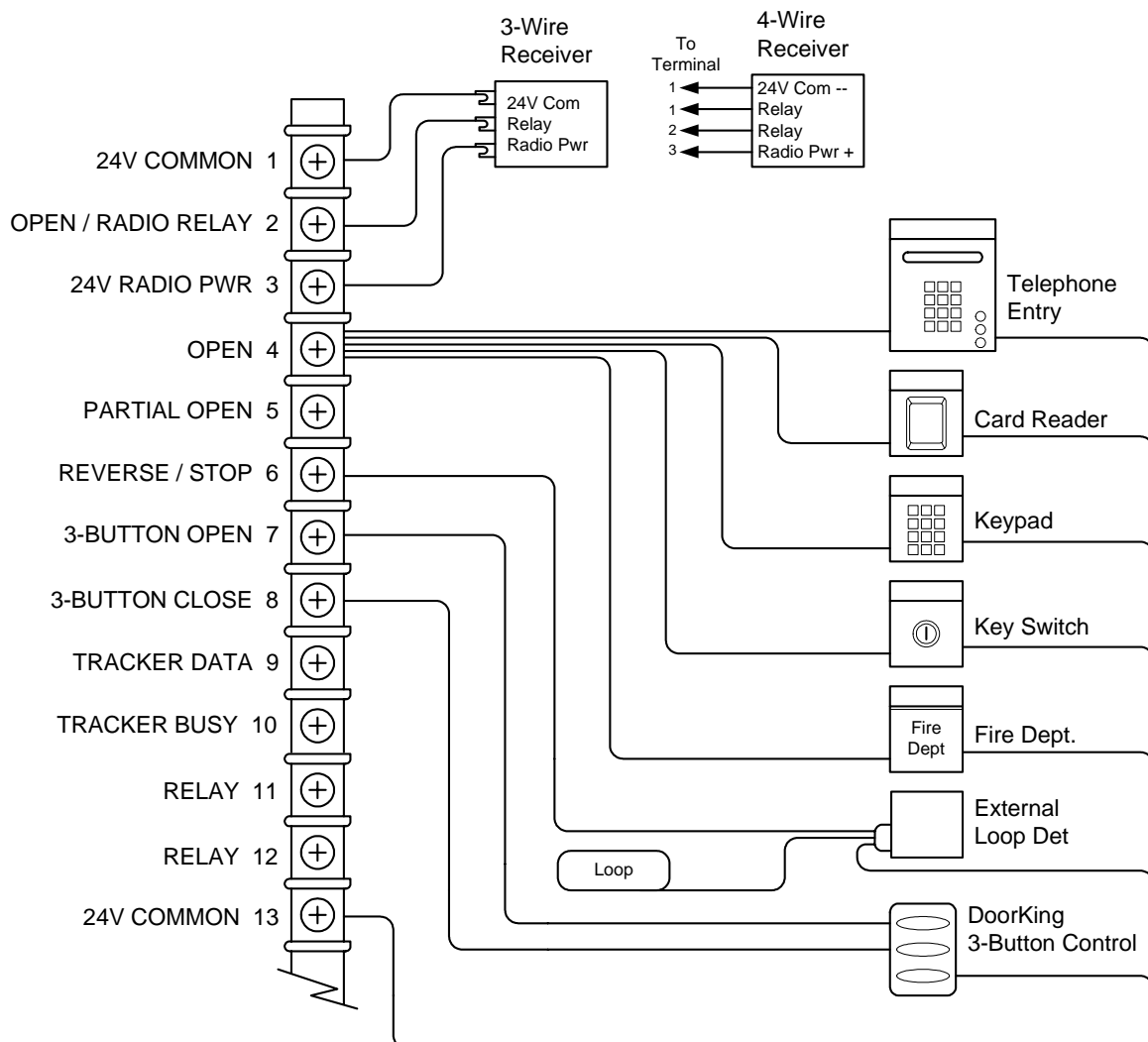

## 2.4 Secondary Entrapment Non-Contact Sensors

- Before connecting non-contact or contact sensors, refer to page 32 for operational description of these sensors.
- Disconnect power to the gate operator before installing the non-contact sensors.
- See diagram below for suggested placement of sensors. (Diagram is for illustration purposes only. Actual placement of the sensors is dependent on the installation requirements). One or more non-contact sensors shall be located where the risk of entrapment or obstruction exists, such as the perimeter reachable by a moving gate or barrier.
- Use only UL listed (or equivalent) non-contact sensors.
- Connect the non-contact sensors as shown below to the auxiliary terminal strip located on the 4403 control board. Inputs from photo-beam to circuit board are NORMALLY OPEN.
- Diagram does not show power wiring to photo-beams.
- Open photo-beam must be placed so that it covers that portion of the fence that the gate covers when it is fully open.

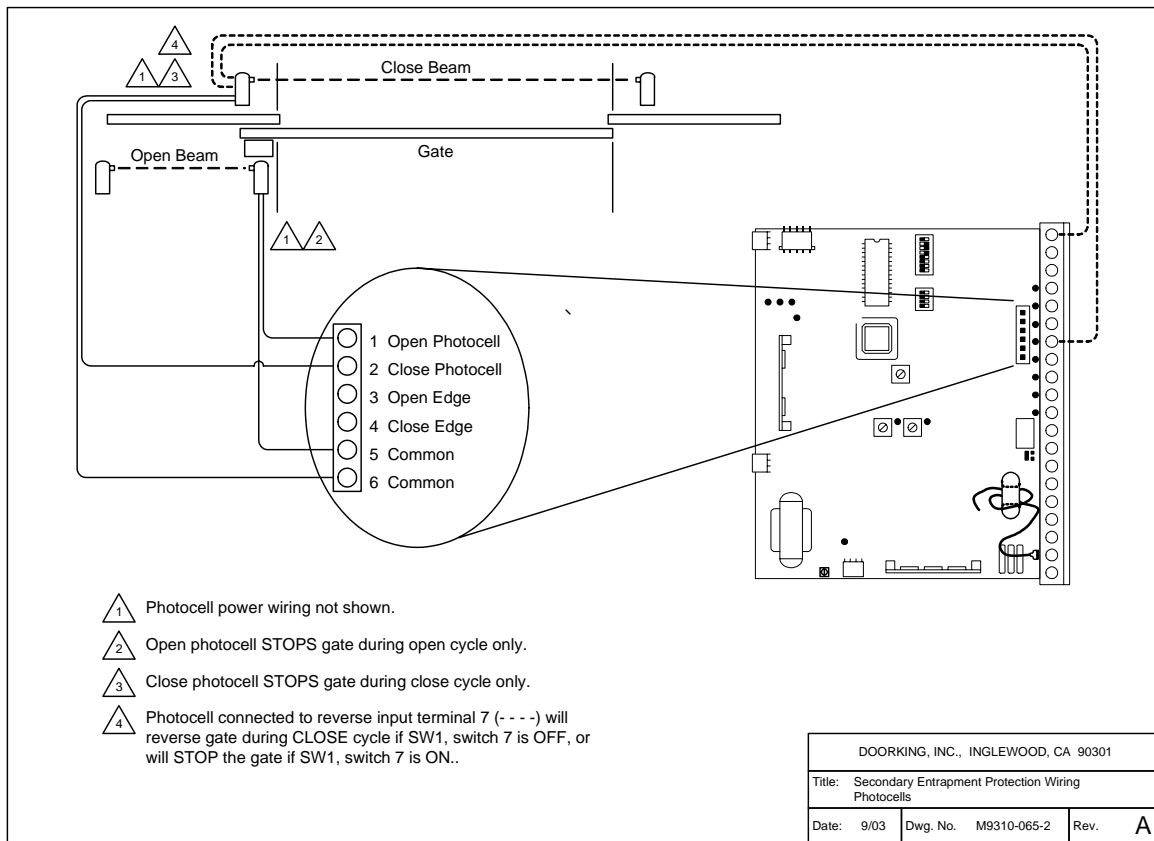



## 2.5 Contact Sensors

- Before connecting non-contact or contact sensors, refer to page 32 for operational description of these sensors.
- Disconnect power to the gate operator before installing the contact sensors.
- Connect the contact sensors as shown below to the auxiliary terminal strip located on the 4403 control board.
- Contact sensors may be located at the leading edge, trailing edge, and post mounted both inside and outside of the vehicular sliding gate. Additional contact sensors may be added for additional protection where an entrapment zone may exist.
- Hardwired contact sensors must be located and wiring arranged so that the communication between the sensor and the gate operator is not subjected to mechanical damage.
- Inputs from sensing edges/receiver to circuit board are NORMALLY OPEN.
- Diagram does not show wiring to RF receiver.

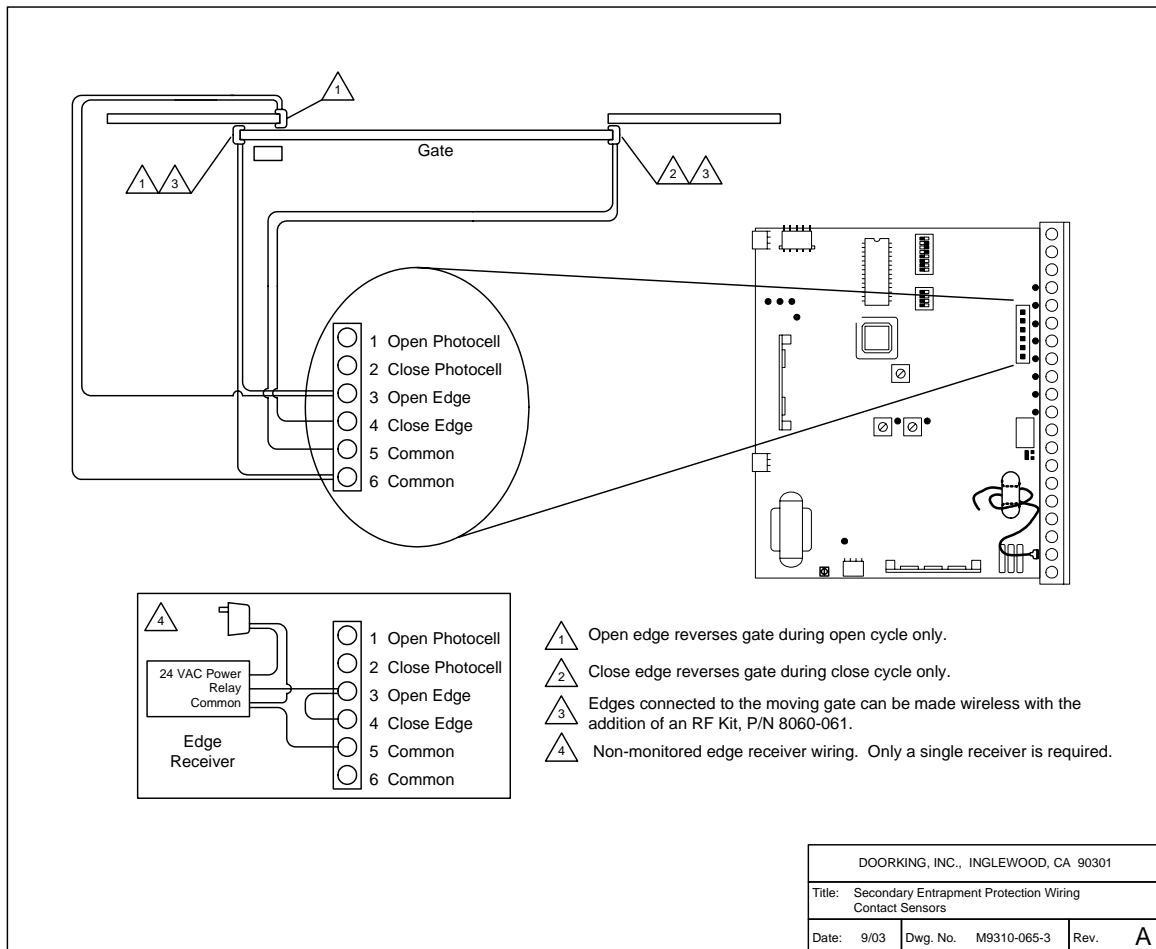

## 2.6 Loop Detectors

Loops and loop detectors must be installed with this gate operator to prevent the gate from accidentally closing on vehicles that may be in the path of the gate.

- Loop detector wiring is shown for DoorKing model 9406 Plug-In loop detector only. If other loop detectors are used, refer to the installation instructions supplied with those detectors for wiring requirements.
- If other loop detectors are used, all inputs to the terminal strip are NORMALLY OPEN. Use a separate power supply to power external detectors. Be sure that power is turned off prior to making any connections to the terminal strip.
- Loop layout shown is for a typical slide gate application with two-way traffic or one-way exit only traffic. For one-way entry only traffic, the exit loop and loop detector are not needed.
- Refer to the separate Loop Information Manual (available from DoorKing) for instructions on installing loops or preformed loops.
- Reverse loops are wired in series (detail A)!

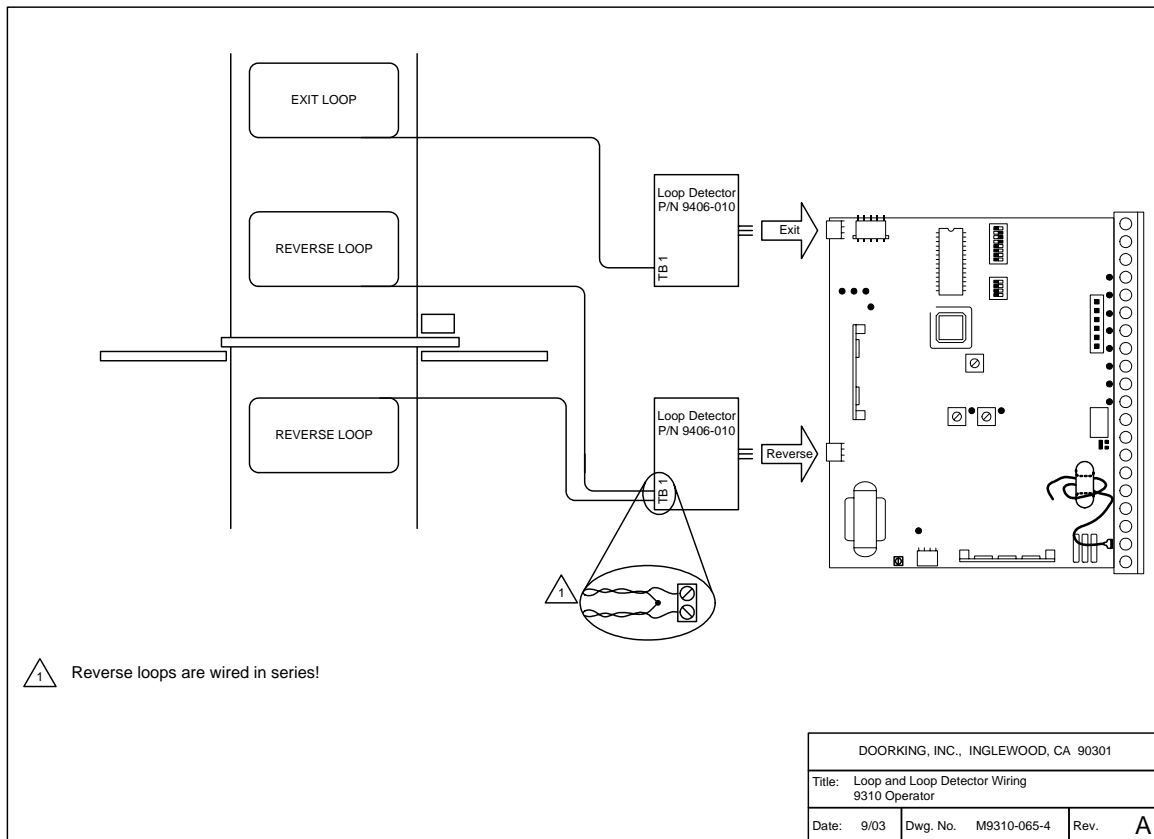

## 2.7 Gate Tracker

This gate operator is equipped with outputs from the circuit board that will report operator status to a companion DoorKing Access Control System (Model 1833, 1835, 1837 or 1838) when equipped with an optional Tracker expansion board. This report includes items such as gate operator cycle count, any shorted inputs, loop detector problems, any attempts to force the gate open, if the gate has struck anything during the open or close cycle, power interruptions, etc.

Gate Tracker™ connections are made at terminals 1, 3, 4, 9 and 10 on the main terminal strip. For more detailed information on Gate Tracker™ and wiring to the Tracker expansion boards, refer to the Tracker Installation and Wiring Manual, DoorKing P/N 2351-010.

Maximum wire run for gate operator data to the tracker board is 500 feet using Belden #9931 shielded cable or Consolidated #5324-CL shielded cable. **Float the shield at the tracker board. Do not connect the shield to the tracker board common.**

Wire connection from the tracker board terminal P1-5 to the 4403 main terminal 4 is optional **if the gate operator is not to be activated by the tracker output relay.**

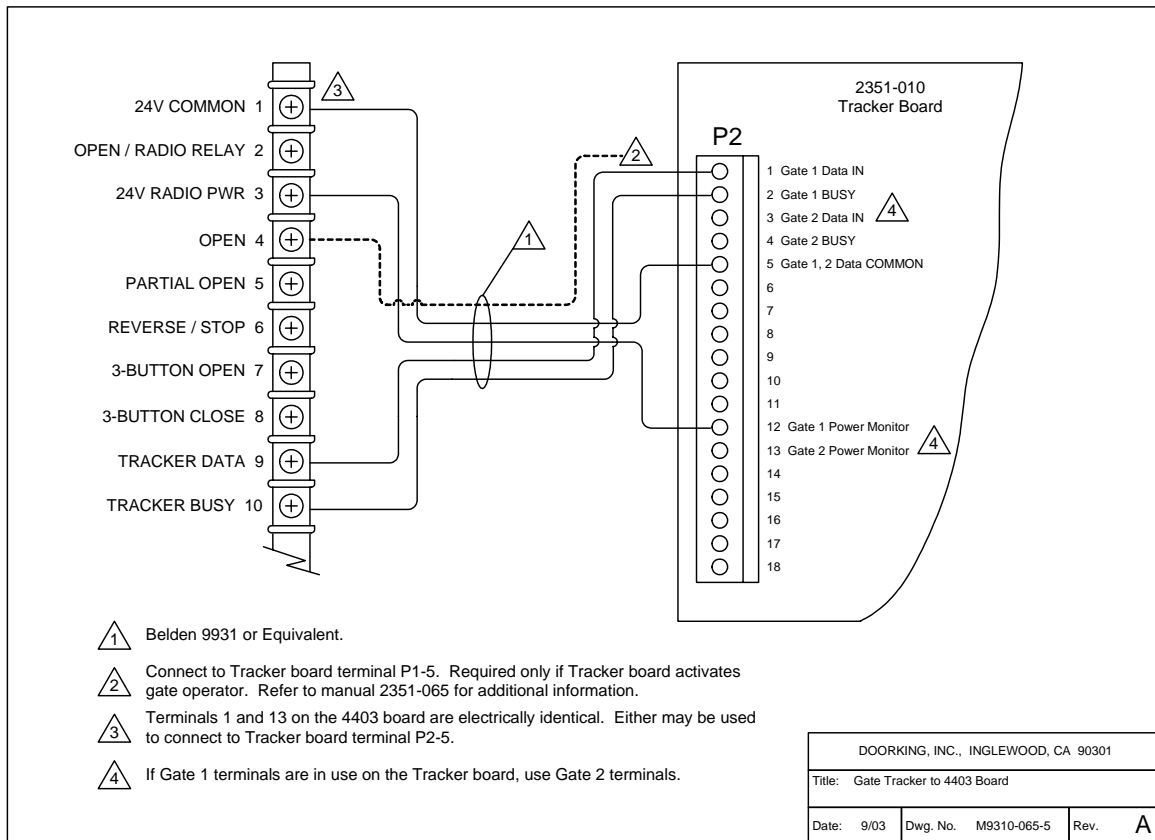

## 2.8 Alarm Reset Switch

The gate operator is equipped with a built-in reset switch that will silence the entrapment alarm and return the operator to normal operation after a hard shutdown occurs. An auxiliary reset button may be added provided that the following condition is met.

- **The alarm-reset button must be located in the line of sight of the gate.**

Connect the normally open alarm-reset switch to auxiliary terminals 13 and 15.

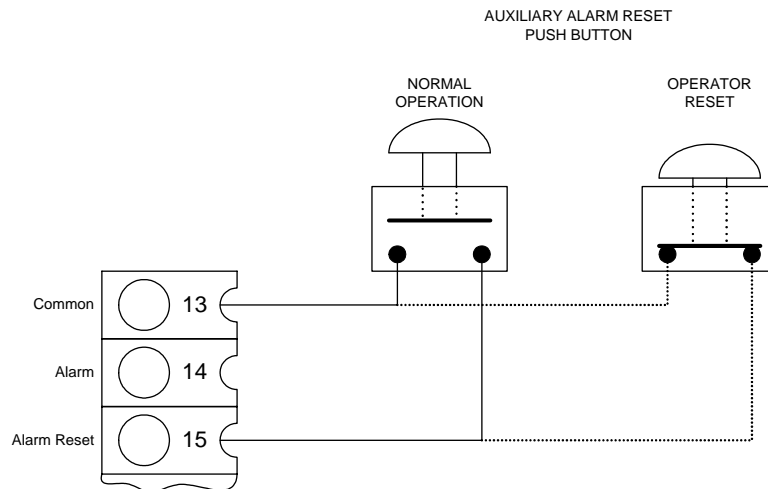

## 2.9 Auxiliary Stop Switch

This circuit creates an auxiliary stop input that will stop a moving gate when activated, or will prevent the gate operator from starting if the switch is activated. **Note that this stop input is normally open and that a switch closure will activate the stop function. Because this is a normally open circuit, the stop switch is not intended and should never be used as a safety interlock device.**

- This circuit cannot be used if a DoorKing 3 button control station is connected to the operator.
- Place a jumper wire from terminal 7 to terminal 8.
- Connect the stop switch to terminals 7 and 13.

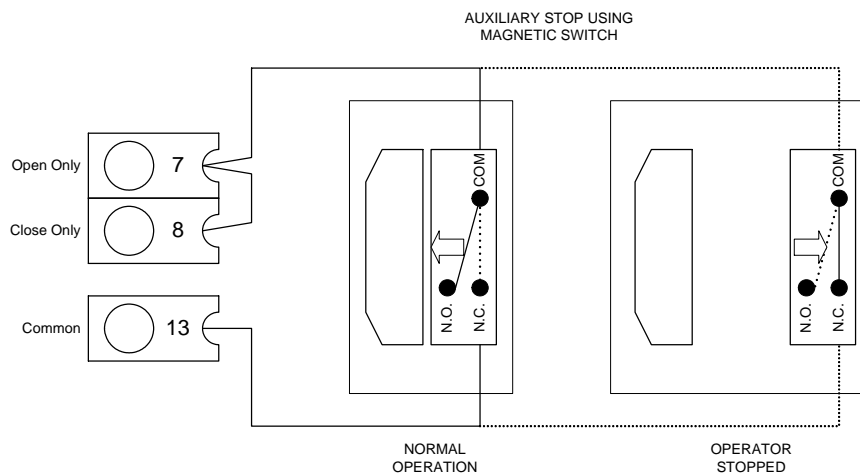

## 2.10 Master / Slave Wiring

The interface wiring between the two operators requires four (4) 18 AWG wires for control. Each operator must be connected to its own power source as described in section 2.2. Be sure that both operators are wired to the same phase in the breaker panel. Check at the breaker panel by measuring voltage from HOT to HOT. This should read 0 volts. If the meter reads 230 Volts, change the wiring. The loop functions are controlled by a two-channel loop detector (P/N 9405-010) plugged into the OPEN port on the operator that is designated as the master unit. Color code shown assumes use of DoorKing master / slave cable, part number 2600-755 (30 ft.), 2600756 (40 ft.), 2600-757 (50 ft.).

1. Connect the master / slave wiring main terminals 1, 4, 6 and external sensor terminal 2 as shown below. Be sure that power to both operators is OFF.
2. Set SW 1, switch 3 to the OFF position in this operator. Place a jumper from terminal 2 to terminal 4.
3. Plug the 9405 loop detector into the OPEN loop port. Connect the leads from the EXIT loop to TB 1. Connect the leads from the REVERSE loop(s) to TB 2. Connect TB 3 Normally Open (N.O.) to terminal 6. Connect TB 3 Common (C) to terminal 13.
4. Connect the radio receiver as shown.
5. Connect any other OPEN devices to terminals 4 and 13. Connect standard external REVERSING devices to terminals 6 and 13. See section 2.7.2 for secondary entrapment prevention device wiring for master / slave operators.

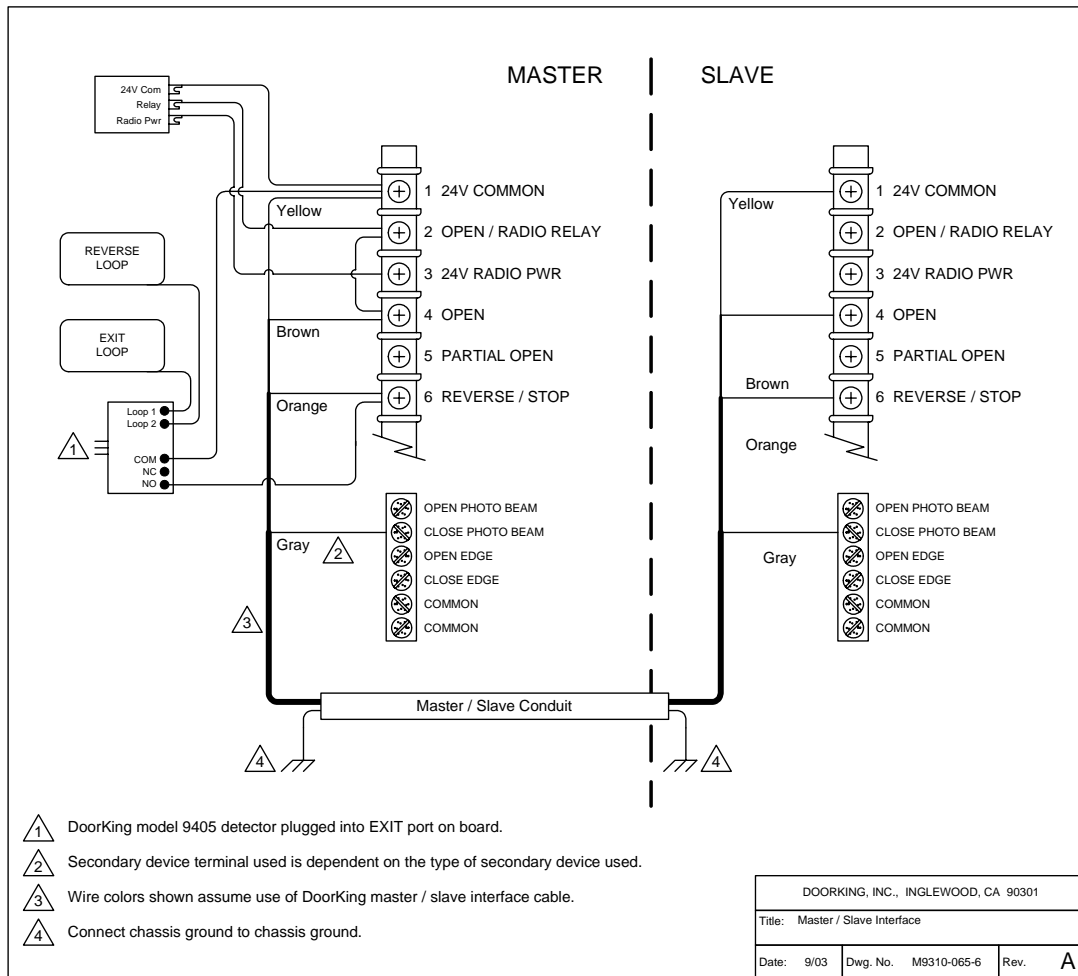

## 2.11 Secondary Entrapment Protection for Master / Slave Configuration

Secondary entrapment protection for slide gate operators connected in a master / slave configuration will require three sets of photo-beams to insure protection.

- One photo-beam is directed across the roadway and connected to the CLOSE photo-beam input on the auxiliary terminal strip of both the master and slave operator. This photo-beam is active in the close direction only and will not affect the movement of the gates while the gates are opening.
- Two photo-beams are required to protect the open direction of the gates - one for the master operator and one for the slave operator. These photo-beams are connected to the OPEN photo-beam input on the auxiliary terminal strip in their respective operator. These photo-beams are active in the open direction only. If a beam is interrupted while the gate(s) are in the open cycle, only the gate that is controlled by the interrupted beam will stop, the other gate will continue in the open direction.

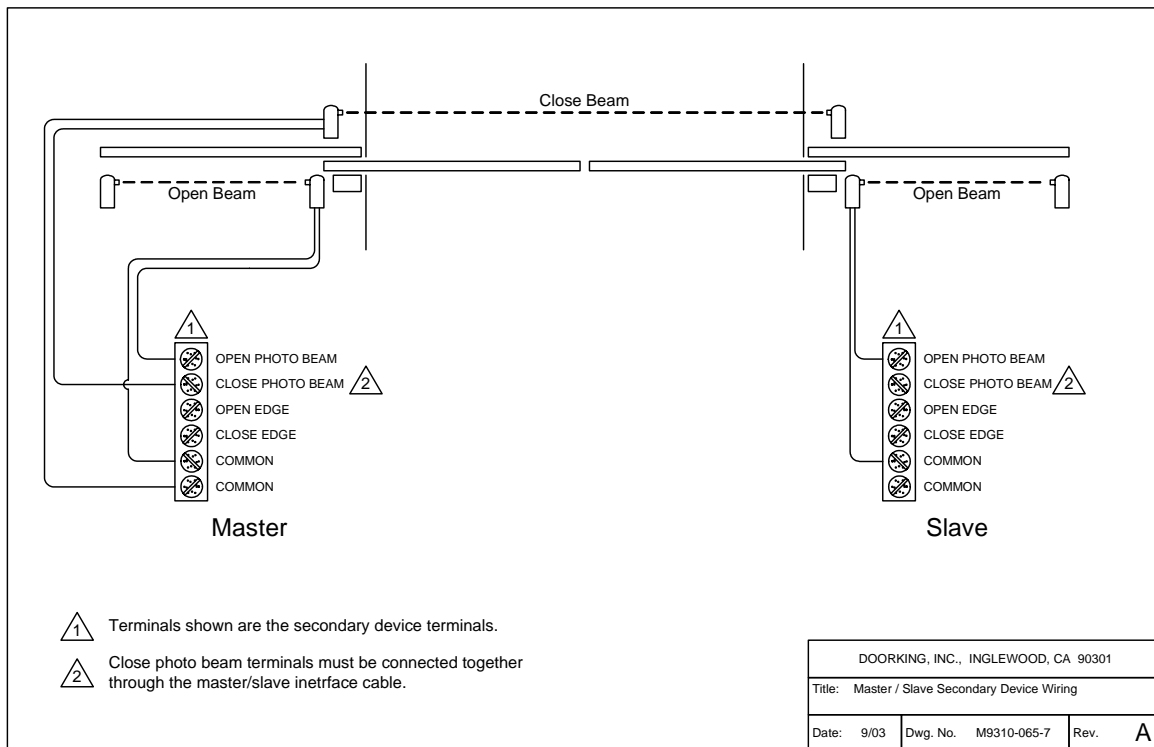

## 2.12 Main Terminal (P1) Description

1. 24 VOLT COMMON  
Same as terminal 13.
2. OPEN / RADIO RELAY  
Functions same as terminal 4.
3. 24 VOLT RADIO POWER
4. FULL OPEN / CLOSE INPUT  
When gate is closed, input will open gate to full position.  
When gate is open and auto close timer is turned on, input will re-set and hold timer.  
When gate is open and auto close timer is turned off, input will close gate.  
When gate is closing, input will reverse gate.
5. PARTIAL OPEN INPUT  
Gate will open to PARTIAL limit setting. Functions same as terminal 4.
6. STANDARD REVERSE / STOP INPUT  
When gate is fully closed or in the opening cycle, this input has no affect on the gate operator.  
When gate is open and auto close timer is turned ON, input will re-set and hold timer.  
When gate is open and auto close timer is turned OFF, input will prevent gate from closing.  
When gate is closing, input will REVERSE gate if SW 1, switch 7 is OFF.  
When gate is closing, input will STOP gate if SW 1, switch 7 is ON.
7. OPEN INPUT - Use with DoorKing 3 button control station only (P/N 1200-006).
8. CLOSE INPUT - Use with DoorKing 3 button control station only (P/N 1200-006).
9. GATE TRACKER - DATA
10. GATE TRACKER - BUSY
11. DRY RELAY CONTACT  
Operation of relay is dependent on setting of SW 1, switches 4 and 5. Relay contacts can be set for Normally Open (NO) or Normally Closed (NC) operation. Contact rating is 1 amp maximum at 24 Volts.
12. DRY RELAY CONTACT
13. 24 VOLT COMMON  
Same as terminal 1.
14. ALARM OUTPUT
15. ALARM RESET
16. SOLENOID LOCK
17. MOTOR
18. MOTOR
19. 115 VAC HOT
20. 115 VAC NEUTRAL

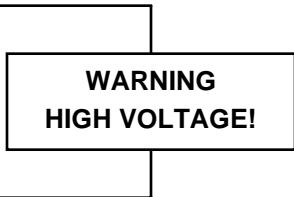

## 2.13 Secondary Device Terminal (P3)

External entrapment prevention devices are connected here.

1. **OPEN PHOTO-BEAM**  
This input is only active when the gate is in the opening cycle. An open photo-beam input during the opening cycle will cause the gate to stop. The gate will remain stopped until the photo-beam input is cleared, at which time the gate will resume the open cycle.
2. **CLOSE PHOTO-BEAM**  
This input is only active when the gate is in the closing cycle. A close photo-beam input during the closing cycle will cause the gate to stop. The gate will remain stopped until the photo-beam input is cleared, at which time the gate will resume the close cycle.
3. **OPEN EDGE**  
This input is only active when the gate is in the opening cycle. An open edge input during the opening cycle will cause the gate to stop and then reverse.

If the gate reaches the full closed position, the gate will remain closed, ignore any maintained inputs and enter a soft shutdown condition. NOTE: If the gate was initially activated by a time clock with a contact closure across the gate operator open input, this input will be ignored until another input (open loop, reverse loop. etc.) is received by the gate operator.

If a close edge sensor is activated prior to the gate reaching the full closed position, the gate will stop and enter a soft shutdown condition.

4. **CLOSE EDGE**  
This input is only active when the gate is in the closing cycle. A close edge input during the closing cycle will cause the gate to stop and then reverse.  
  
If the gate reaches the full open position, the timer will automatically close the gate (if it is turned on). Once the gate starts to close again, if the close edge input is activated a second time prior to the gate reaching the full closed position, the operator will stop and reverse and will enter a soft shutdown condition.  
  
If an open edge sensor is activated prior to the gate reaching the full open position, the gate will stop and enter a soft shutdown condition.

5. **COMMON**  
Common terminal for the secondary entrapment protection device inputs.
6. **COMMON**



# SECTION 3 - ADJUSTMENTS

The switch settings and adjustments in this chapter should be made after your installation and wiring to the operator(s) is complete. Whenever any of the programming switches on the circuit board are changed, power must be shut-off, and then turned back on for the new setting to take effect.

## 3.1 Circuit Board Adjustments

- Set the DIP-switches on the circuit board to the desired setting. See switch-setting charts in section 3.2.
- Auto close timer (when turned on) can be set from 1 second (full counter clockwise) to approximately 23 seconds (full clockwise).
- Dry contact relay (terminals 11-12) can be set for Normally Open (NO) or Normally Closed (NC) operation by placing the relay shorting bar on the NO or NC pins respectively.
- Power LED indicates that low voltage power is applied to the circuit board. Input LEDs should be OFF and will only illuminate when the input is activated. The limit LED will be ON when the respective limit switch is activated.

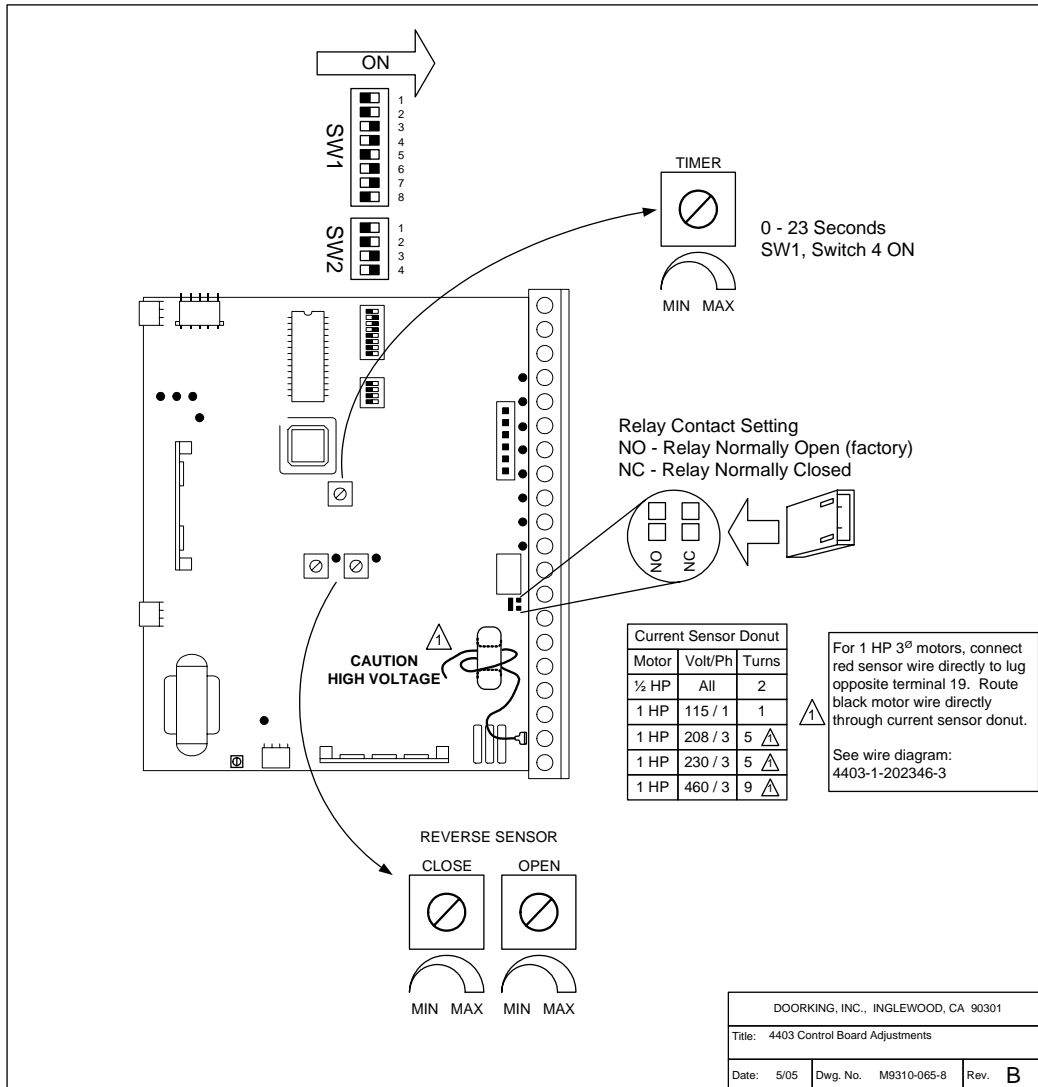

### 3.2 Switch Settings

The two DIP-switches located on the circuit board are used to program the operator to operate in various modes and to turn on or off various operating features. Whenever a switch setting is changed, power to the operator must be turned OFF and then turned back on for the new setting to take affect. **Check and review ALL switch settings prior to applying power to the operator.**

SW 1 (UPPER SWITCH)			
SWITCH	FUNCTION	SETTING	DESCRIPTION
1	Direction	OFF ON	Changes open / close direction of operator.
2	Auto Close Timer	OFF ON	Auto-close timer is OFF. Manual input required to close gate. Auto-close timer is ON. Adjustable from 1-23 seconds.
3	Open Loop Output	OFF  <b>ON</b>	Switches logic-level output of EXIT loop port to terminal 4 and removes terminal 4 as an open input. <b>Normal Setting.</b> Control board responds internally to loop detector plugged into exit loop port.
4 & 5	Relay & LED	4-OFF 5-OFF 4-OFF 5-ON 4-ON 5-OFF 4-ON 5-ON	Relay activated and LED on when gate is FULL OPEN. Relay activated and LED on when gate is NOT CLOSED. Relay activated and LED on when gate is OPENING and OPEN. Relay activated and LED on when gate is OPENING or CLOSING.
6	Solenoid Lock (see note 1)	<b>OFF</b>  ON	<b>Normal setting.</b> Fail-safe logic. Lock engages only if attempt is made to force gate open. Fail-secure logic. Lock engages after each cycle.
7	Reverse  Stop	<b>OFF</b>  ON	<b>Normal Setting.</b> Input to terminal 6 or reverse detector will REVERSE gate during close cycle. Input to terminal 6 will or reverse detector STOP gate during close cycle.
8	Timer Override	OFF ON	Normal Gate Operation. Opening gate will stop and begin to close as soon as all reversing inputs (loops, beams) are clear regardless of the open position of the gate.

SW 2 (LOWER SWITCH)			
SWITCH	FUNCTION	SETTING	DESCRIPTION
1	Self Test (see note 2)	<b>OFF</b> ON	<b>Normal setting.</b> Run self-test – bench test only.
2	Open Uphill	<b>OFF</b> ON	<b>Level – Normal Setting.</b> Gate opens uphill.
3	Slide Gate  Overhead Gate	<b>OFF</b>  ON	<b>Normal setting.</b> Must be in the OFF position for slide gate operators.
4	Close Uphill	<b>OFF</b> ON	<b>Level – Normal Setting.</b> Gate closes uphill.

#### NOTES:

1. Do not change the setting of this switch unless the solenoid/lock assembly has been repositioned for the operation desired. Changing the setting of this switch without physically changing the lock assembly will damage the operator.
2. Do not run the self-test while the gate operator is connected to the gate. This self-test feature is designed for bench-testing only.

### **3.3 Programming Switch Description and Function**

#### **8-DIP (Top) Switch**

**Switch 1:** Set so that the operator cycles open upon initial power up and open command. If the operator cycles close, turn power off and change the setting on this switch.

**Switch 2:** Turns the auto close timer on or off. Set from 1 to 23 seconds. **Loops and loop detectors, photoelectric cells, or other like devices must be installed when the auto close timer is used to prevent the gate from closing on vehicular traffic.**

**Switch 3:** Determines if the output of the loop detector (DoorKing loop detectors only) plugged into the EXIT port will be sent directly to the microprocessor to open the gate, or if the output is directed to terminal 4 where it can then be connected to other input terminals. **If switch 4 is ON, terminal 4 no longer functions as an open input.**

**Switches 4-5:** These work in conjunction with each other and determine when the relay on the board will be activated. This relay can be used as a switch for various functions such as illuminating a warning light when the gate is moving, or turning on a green light when the gate is full open. If a magnetic lock is used with the gate operator, these switches must be set for magnetic lock operation which limits the relay to activate only when the gate is opening and full open.

**Switch 6:** This switch determines the operation of the solenoid lock and is factory set. CAUTION: Do not change the setting of this switch unless the solenoid / lock assembly has been repositioned for the operation desired. Changing the setting of this switch without physically changing the lock assembly will damage the operator.

**Switch 7:** Determines if an input to terminal 6 will reverse or stop a closing gate. If this switch is set to stop the gate (ON), once the input to terminal 6 or the reverse loop detector IS CLEARED, the gate will continue to close. This is typically used to help prevent tailgating.

**Switch 8:** Turning the timer override feature on will cause the auto close timer to close the gate after 1 second, regardless of the setting of the auto close timer potentiometer. This will also cause an opening gate to stop and reverse when the reverse (loop) inputs are cleared. This feature, along with switch 6 above, is useful to prevent tailgating.

#### **4-DIP (Bottom) Switch**

**Switch 1:** This switch must be in the OFF position for normal operation. The self-test feature checks various functions of the operator. CAUTION - Do not run self-test with the operator connected to the gate. The drive chain must be disconnected from the operator to run the self-test.

**Switch 2:** This switch should be left in the OFF position when the slide gate is running on a level or small incline track and the gate does not coast. Turn this switch ON if the gate opens in the uphill direction.

**Switch 3:** Sets the circuit board to function with slide gate operators (switch OFF) or overhead gate operators (switch ON). This switch must be left in the OFF position for model 9310 Slide Gate Operator.

**Switch 4:** This switch should be left in the OFF position when the slide gate is running on a level or small incline track and the gate does not coast. Turn this switch ON if the gate closes in the uphill direction.

### 3.4 Limit Switch Adjustments

1. Be sure that power to the operator is OFF.
2. Push the gate to the open position. Adjust the OPEN limit nut so that it is activating the OPEN limit switch.
3. Push the gate to the close position. Adjust the CLOSE limit nut so that it is activating the CLOSE limit switch.
4. After adjusting the limit-nuts, be sure that the lock-plate is engaged in the slots on the limit-nuts to prevent them from slipping.
5. Turn power on and activate the gate operator. If gate runs towards the close position, turn power OFF and change direction switch (SW-1, switch 1). Turn power ON and activate the gate operator.
6. Re-adjust the limit-nuts as necessary for full-open and full-close gate travel.
7. If the partial open feature is used (input to terminals 1 and 5), the partial open distance can be adjusted by moving the magnetic pick-up across its slotted bracket. Be sure that the magnet imbedded in the center limit nut is aligned with the partial open magnetic pick-up on the bracket.

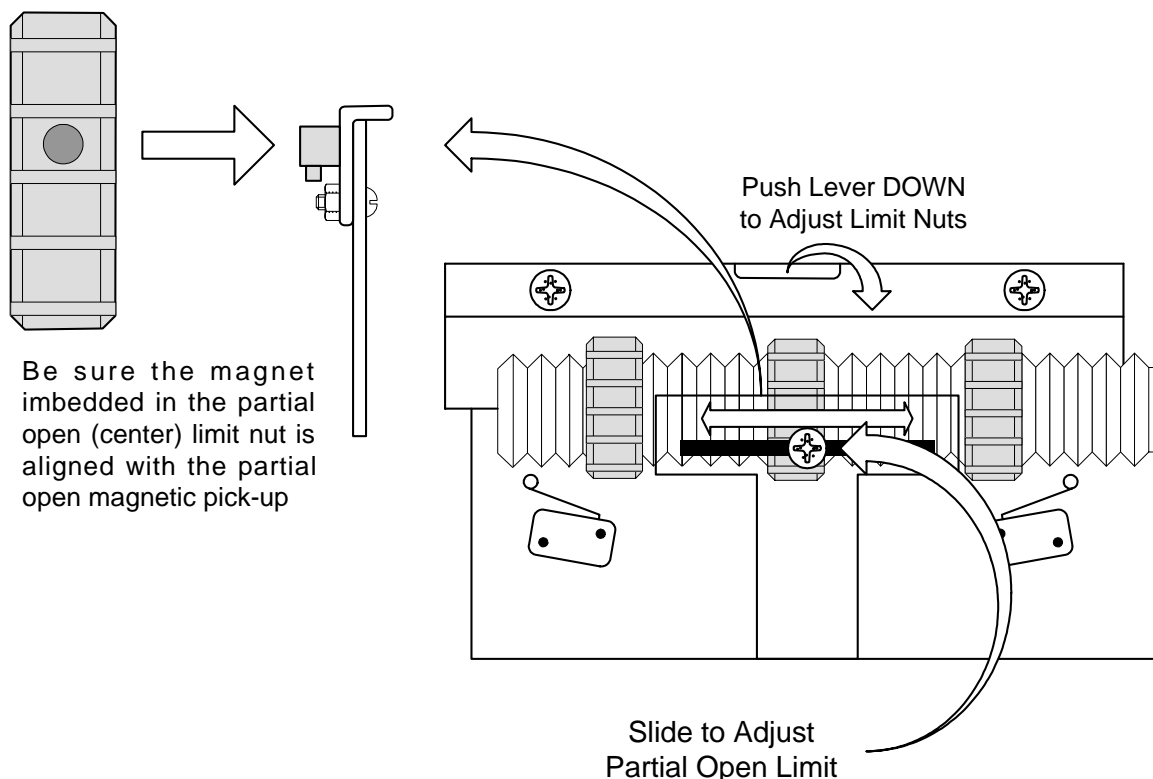

#### **IMPORTANT! 3-Phase Power Limit Switch Test**

**This test MUST be performed if the 9310 is powered from a 3-phase power source.**

1. Activate the operator and watch the limit nut movement.
2. Manually activate the limit switch that the limit nut is moving towards. If the operator does not shut off, immediately turn the operator power off and shut off power at the breaker panel.
3. Reverse the input power wires at L1 and L2.
4. Re-apply power and repeat the test.

### 3.5 Reverse Sensitivity Adjustment

This vehicular gate operator is equipped with an inherent (Type A) entrapment sensing system. This system will sense an obstruction in either the opening or closing gate cycles and will cause the gate to reverse direction should an obstruction be encountered. **For this system to function correctly, the gate must be properly installed and work freely in both directions. A good set of ball bearing wheels (or rollers) is essential for proper slide gate operation.**

1. Activate the gate operator by momentarily shorting terminal 1 and 4 with a 1-foot piece of 18 AWG wire. Be sure that the limit adjustment has been completed as described in section 3.3.
2. While the gate is running open, slowly rotate the open reverse sensitivity potentiometer clockwise until the gate reverses travel, then rotate the potentiometer 1/8 turn counter clockwise. Note: Rotating the sensitivity adjustment clockwise **INCREASES** the reverse sensitivity. Rotating this adjustment counter-clockwise **DECREASES** the reverse sensitivity. NOTE: After the gate has reversed, the operator will assume a "soft shutdown" making it necessary to initiate the cycle again by momentarily shorting across terminals 1 and 4 as in step 1.
3. While the gate is running closed, slowly rotate the close reverse sensitivity potentiometer clockwise until the gate reverses travel, then rotate the potentiometer 1/8 turn counter clockwise. Note: Rotating the sensitivity adjustment clockwise **INCREASES** the reverse sensitivity. Rotating this adjustment counter-clockwise **DECREASES** the reverse sensitivity. NOTE: After the gate has reversed, the operator will assume a "soft shutdown" making it necessary to initiate the cycle again by momentarily shorting across terminals 1 and 4 as in step 1.
4. Operate the gate a few times to be sure that it cycles completely.
5. Place an immobile object along the path of the gate so that the gate will strike it while in the open cycle. The gate must reverse direction after striking the object. If it does not, increase the reverse sensitivity by turning the potentiometer 1/8 turn clockwise, then repeat this test. NOTE: After the gate has reversed, the operator will assume a "soft shutdown" making it necessary to initiate the cycle again by momentarily shorting across terminals 1 and 4 as in step 1.
6. Place an immobile object along the path of the gate so that the gate will strike it while in the close cycle. The gate must reverse direction after striking the object. If it does not, increase the reverse sensitivity by turning the potentiometer 1/8 turn clockwise, then repeat this test. NOTE: After the gate has reversed, the operator will assume a "soft shutdown" making it necessary to initiate the cycle again by momentarily shorting across terminals 1 and 4 as in step 1 to reactivate the automatic close timer.
7. You may have to repeat step 2 several times to find the correct sensitivity adjustment.

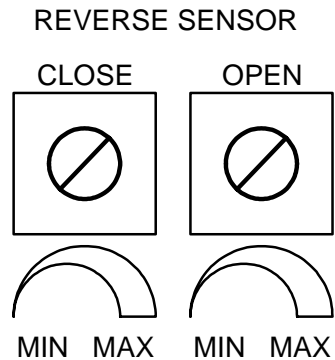



## **SECTION 4 – OPERATING INSTRUCTIONS**

**WARNING - To reduce the risk of injury or death:**

1. READ AND FOLLOW ALL INSTRUCTIONS.
2. Never let children operate or play with gate controls. Keep the remote control away from children.
3. Always keep people and objects away from gate. **NO ONE SHOULD CROSS THE PATH OF THE MOVING GATE**
4. Test the operator monthly. The gate **MUST** reverse on contact with a rigid object or stop or reverse when an object activates the non-contact sensors. After adjusting the force or the limit of travel, retest the gate operator. Failure to adjust and retest the gate operator properly can increase the risk of injury or death.
5. Use the emergency release only when the gate is not moving and power has been shut-off.
6. **KEEP GATES PROPERLY MAINTAINED.** Read the owner's manual. Have a qualified service person make repairs to gate hardware.
7. The entrance is for vehicles only. Pedestrians must use separate entrance.
8. **SAVE THESE INSTRUCTIONS.**

### **4.1 Power and Reset Switches**

Open the power switch cover located on the side of the operator to access the MAIN POWER switch and the operator RESET switch.

- The RESET switch is used to turn off the entrapment alarm and to reset the operator after a hard shutdown has occurred.
- The AC POWER toggle switch turns power to the operator ON (toggle up) or OFF (toggle down).
- The DC POWER toggle switch (units equipped with the backup option only) turns power to the DC backup system ON (toggle up) or OFF (toggle down).

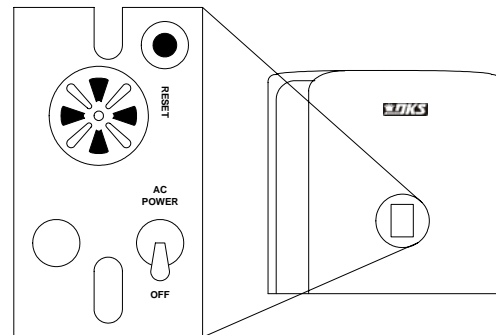

## **4.2 Shutdown Conditions**

Under various entrapment conditions the operator will assume either a soft or hard shutdown (alarm) condition. To determine what type of reset action is required, you will need to understand how the different entrapment conditions affect the gate operator.

### **Soft Shutdown**

This occurs in various situations where the inherent or secondary entrapment protection devices have been activated. In a soft shutdown condition, the operator will not respond to any input that was present when the entrapment protection device sensed an obstruction. If the gate stops at the open position, the operator will not respond to the automatic close timer.

- Example 1: A time clock keys the gate open in the morning and an entrapment protection device senses an obstruction prior to the gate reaching the full open position. If the entrapment is sensed by the inherent system, the gate will reverse and run back to the closed position. The time clock input is still present, but the gate will not re-open.

NOTE: In some systems, the time clock input comes from the telephone entry system relay. This same relay may also provide open commands for a card reader, MicroPLUS transmitters and the visitor telephone entry. If so, these devices will also be disabled in a soft shutdown condition.

- Example 2: If the gate is closing and an entrapment protection device is activated, the gate will either stop or reverse and run back to the open position, depending upon if the secondary or inherent device was activated. The automatic close timer will not close the gate.
- Example 3: Vehicle arrives at open loop and the gate runs towards the open position. The inherent entrapment protection is activated. The gate reverses and runs back to the closed position. If the vehicle is still present at the open loop a soft shutdown condition does not occur. The loop input provides an immediate reset of the operator and the gate will again run to the open position.

### **Resetting a Soft Shutdown**

In some conditions, a soft shutdown will reset as soon as the entrapment condition clears. For example, if a non-contact sensor (photo cell) is sensing an obstruction, the operator will stop the gate and assume a soft shutdown condition. When the photocell clears, the operator will return to normal operation.

When the operator is in a soft shutdown, activation of any "intended input" will reset the operator. An "intended input" includes any command, any standard safety input and any loop input. Activating any of these inputs will reset the gate. At that point the gate will return to normal operation. If the gate is open, the automatic close timer will then time out and close the gate.



## **Hard Shutdown**

A hard shutdown condition occurs when the inherent entrapment protection system has sensed two consecutive obstructions before the gate reaches the full open or full closed position. **It can also be an indication that the gate is too heavy or that the gate hardware (wheels, rollers) is in poor condition and needs to be corrected.** Do not reduce the operator reversing sensitivity in an attempt to correct for a poorly designed gate or for hardware that is in need of repair.

- Example: The gate is closing and the inherent entrapment protection system senses an obstruction and causes the gate to reverse direction. As the gate begins to run in the open direction, a second obstruction is sensed prior to the gate reaching the full open position. Once the second obstruction has been sensed, the operator will stop, the audio alarm will be activated and all standard inputs are shut down (including open commands, safety commands, loop inputs, etc.).
- NOTE: The audio alarm will remain activated for a maximum of five minutes, or until the operator receives a reset input. The hard shutdown condition will remain in affect even if the audio alarm shuts off after five minutes.
- After 5 minutes, the audio alarm will “chirp” every 5 seconds. This indicates that the operator is in a hard shutdown condition and the reset switch must be activated to reset the operator and silence the alarm.

## **Resetting a Hard Shutdown**

When the operator is in a hard shutdown condition (audio alarm activated or audio alarm “chirps” every 5 seconds), the only way to reset the gate operator and return it to normal operation is to activate the alarm reset input or turn power off and then back on. An alarm-reset switch can be mounted external of the gate operator provided that it is installed in the line of sight of the gate and gate operator (see 2.8).

- Before resetting a hard shutdown, determine why the shutdown occurred. Inspect the gate for any obstructions along its path that could have activated the inherent entrapment sensing system. Inspect the gate and gate hardware.
- NOTE: DoorKing operators have a built-in alarm reset push button mounted on the operator above the power ON-OFF toggle switch. Activating this button will return the gate operator to normal operation, but will not activate the gate operator.

Once the gate has been reset, an open or close command is needed to start the gate operator. Most activating commands will cause the gate operator to cycle to the open position. This includes activation of a key switch or open command and activation of an open loop. Activation of a close command will run the gate to the closed position.

- NOTE: The gate operator will not lose its limit settings when a hard shutdown occurs.

### **4.3 Manual Gate Operation**

This operator is equipped with a manual release system that will allow the gate to be pushed open in the event of a power outage or equipment failure.

There are two manual release systems that are available on this gate operator. The standard type release is the FAIL-SAFE system (required by many city codes), while an optional release is the FAIL-SECURE system.

**NOTE: Never attempt to manually push open any gate with an operator attached to it until you have verified that power to the operator has been shut-off.**

#### **Emergency Vehicle Access Conditions**

The automatic vehicular gate system must be designed to allow access to emergency vehicles under different operating conditions.

1. During normal powered operation, emergency vehicles access the gate by use of the emergency vehicle access device installed on your gate system. The type of device that is used in your community is dependent on your city codes. These devices may include (but are not limited to) Fire Department lock boxes, Click-2-Enter radio receivers, strobe light sensors, siren sensors, etc.
2. In the event of a power failure, the emergency vehicle access device may not be functional because the gate operator is un-powered. If the gate operator is equipped with a battery back-up system, this system will automatically open the gate when primary (AC) power is removed. NOTE: DC powered back-up systems are optional and your gate system may or may not be equipped with one. Check with your installer to determine if your gate system is equipped with a back-up power system.
3. In the event of a primary (AC) power failure and a back-up system (DC) power failure (low charged or dead batteries for example), the system must have a release system to allow the gate to be manually operated. The release device must be accessible from either side of the gate and must be present so that emergency personnel can gain access through the gate under this condition.

#### **Fail-Safe Manual Operation**

The FAIL-SAFE manual operation system is the most reliable and safest method for placing an automated gate in manual operation and is the preferred method of emergency gate operation under worse case conditions by many Fire Chiefs and Building Inspectors and is typically used in CLASS I and CLASS II applications. This system requires no keys, cranks or other tools for manual gate operation and is completely automatic. This prevents any delays for emergency vehicle access in the event that a power outage has occurred.

- When AC power is removed (power failure or switch power off), the operator "FAILS" in a "SAFE" condition allowing the gate to be manually pushed open without the need of any tools, keys, cranks or other devices. This assures emergency vehicle access under the worst-case conditions.
- For manual fail-safe gate operation, turn power to the operator OFF. If a backup power system is in use, be sure that this power is turned OFF also. Once power is OFF, the gate can be manually operated.

### **Fail-Secure Manual Operation**

The FAIL-SECURE option locks the gate when primary (AC) power is removed and requires a keyed release to place the gate in manual operation. The FAIL-SECURE option is typically used in CLASS III and CLASS IV applications.

- Be sure that primary (AC) and backup (DC) power is removed or shut-off prior to placing the gate operator in manual operation.
- Insert the manual release key into the keyed release on the side of the gate operator, and turn it clockwise 1/4 turn. The gate can now be manually operated.

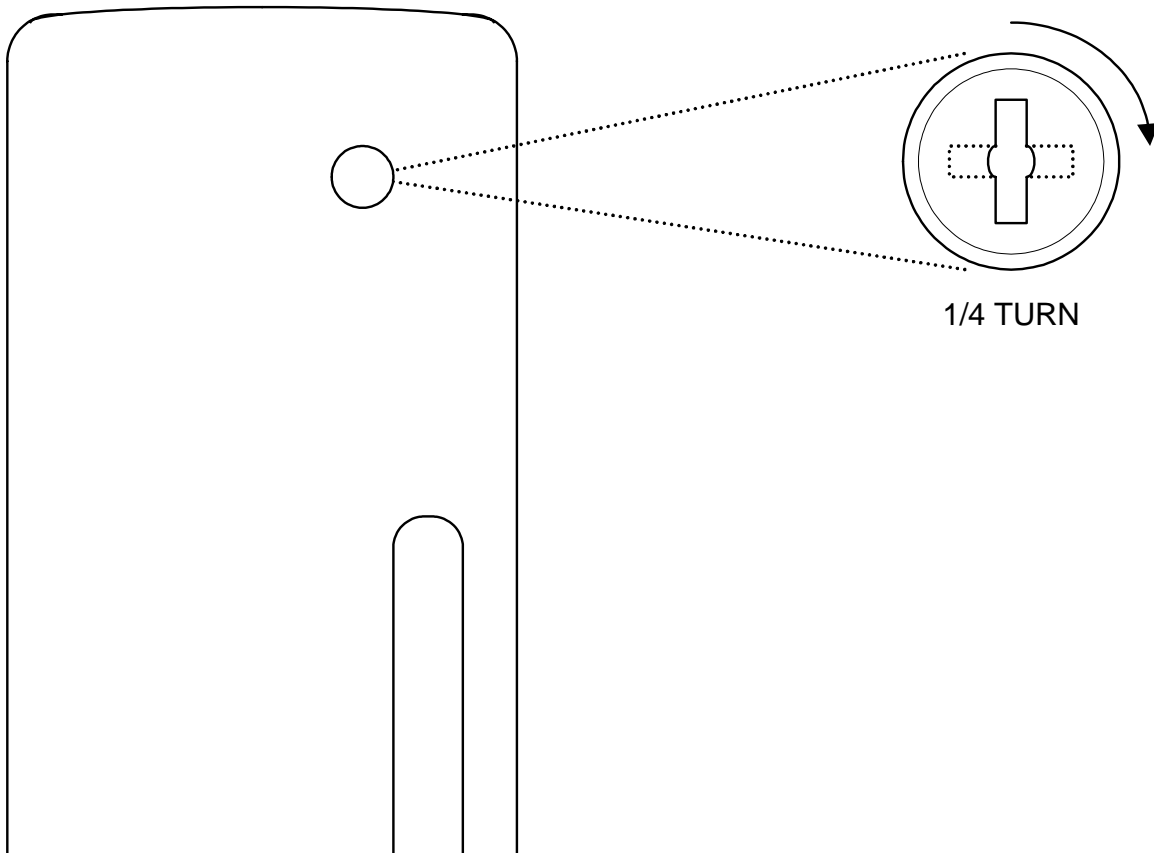



## SECTION 5 – MAINTENANCE AND TROUBLESHOOTING

Inspection and service of this gate operator by a qualified technician should be performed anytime a malfunction is observed or suspected. High cycle usage may require more frequent service checks.

### 5.1 Maintenance

When servicing the gate operator, always check any secondary (external) reversing devices (loops, photo eyes, etc.) for proper operation. If external reversing devices cannot be made operable, do not place this operator in service until the malfunction can be identified and corrected.

**Always check the inherent reversing system when performing any maintenance. If the inherent reversing system cannot be made operable, remove this operator from service until the cause of the malfunction is identified and corrected. Keeping this operator in service when the inherent reversing system is malfunctioning creates a hazard for persons which can result in serious injury or death should they become entrapped in the gate.**

When servicing this gate operator, always turn power **OFF!!**

**If gearbox requires oil, use only SYNTHETIC SHC-629 oil.** Do not completely fill gearbox with oil. Gearbox should be half full only. Do not exceed this level. **Synthetic oil MUST be used!**

MAINTENANCE SCHEDULE		MONTHLY INTERVAL		
		3	6	12
Alarm	Activate the primary (inherent) reverse system by blocking the gate with a solid object. When the gate reverses, block the gate in the opposite direction prior to the limit being reached. The entrapment alarm should activate. Press the reset button to silence the alarm.	✓		
Battery Backup	Check operation of battery backup system by turning AC power OFF.	✓		
Chain	Check for sagging. Tighten if necessary.		✓	
Fire Dept.	Check emergency vehicle access device for proper operation.	✓		
Gate	Inspect for damage. Check gate wheels, rollers and guides for wear and grease if necessary.		✓	
Grease	Wheels and guide rollers if necessary.		✓	
Loop(s)	Check vehicular reverse and shadow loops for proper operation.	✓		
Oil	Check gearbox oil level.		✓	
Primary Reverse System	Check that the gate reverses on contact with an object in both the opening and closing cycles. Adjust reversing sensitivity if necessary.	✓		
Release	Check manual release for proper operation.	✓		
Secondary Reverse Device	Check that secondary (external) reverse device(s) stop or reverse the gate when activated.	✓		
Sprockets	Check set-screws for tightness.		✓	
Complete	Complete check of gate and gate operating system.			✓

## 5.2 Operator Diagnostics

This gate operator is designed with built-in diagnostics that will alert you to potential or existing problems that the microprocessor has detected. Specific fault conditions are checked and the operator will signal that a fault exist through the built-in alarm.

### **Constant tone is heard when power is applied:**

- This indicates that the limit switch wire harness is not connected to the circuit board. In this condition, the operator will not run and the tone will continue until the fault is corrected. Check to be sure that the limit switch plug is properly inserted into P2.

### **Constant tone is heard:**

- This indicates that the operator is in a hard shutdown condition (section 4.2). The tone will continue to sound for five minutes, and then will beep once every five seconds. The operator-reset button must be pressed or power must be removed and then reapplied to return the operator to normal operation.

### **Short tone is heard every five seconds:**

- This indicates that the operator has been in a hard shutdown condition in excess of five minutes. This will continue until the operator-reset button is pressed or until power is removed from the operator.

### **Operator runs for 1 second and stops, two short tones are heard:**

- This indicates that there may be a fault with the current sensor circuit. Check that the red current sensor wire has been passed through the hole in the current sensor donut with the correct number of turns as shown in the table.
- NOTE: For 1 HP 3-phase operators only, the red current sensor wire is connected directly to the spade lug opposite terminal 19 without passing through the current sensor donut. The black motor wire is routed through the donut with the number of turns as shown in the table.

Current Sensor Donut		
Motor	Volt / Ph	Turns
½ HP	All	2
1 HP	115 / 208 / 230 1 <sup>Ø</sup>	1
1 HP	208 – 3 <sup>Ø</sup>	5
1 HP	230 – 3 <sup>Ø</sup>	5
1 HP	460 – 3 <sup>Ø</sup>	9

### 5.3 Trouble Shooting

Have a good VOM meter to check voltages and continuity. A Meg-Ohm meter capable of checking up to 500 meg-ohms of resistance is necessary to properly check the integrity of the ground loops. When a malfunction occurs, isolate the problem to one of three areas: 1) the operator, 2) the loop system, 3) the keying devices. **Use caution when checking high voltage terminals, motor capacitor and the motor.**

1. Check the input indicator LEDs. They should only come ON when a keying device (card reader, push button, etc.) is activated. If any of the input LEDs are ON continuously, this will cause the gate operator to hold open. Disconnect the keying devices one at a time until the LED goes OFF.
2. Check any external secondary entrapment protection devices. Any short or malfunction in these devices can cause the gate operator to stop or to hold open.
3. A malfunction in a loop or loop detector can cause the gate operator to hold open, or to not detect a vehicle when it is present over the loop. Pull the loop detector circuit boards from the loop ports on the operator circuit board. If the malfunction persists, the problem is not with the loop system. For more information on trouble shooting loops and loop detectors, refer to your loop detector instruction sheet and to the DoorKing Loop and Loop Detector Information Manual.
4. Check to be sure that there are no shorted or open control wires from the keying devices to the gate operator. If a keying device fails to open the gate, momentarily jumper across terminals 1 and 5 on the gate operator circuit board. If the gate operator starts, this indicates that a problem exist with the keying device and is not with the gate operator.
5. If a three-button control station (open-close-stop) is connected to this gate operator, check for proper wiring. Only a DoorKing three button control station (P/N 1200-006) can be used with this gate operator. Others will cause a malfunction.
6. Check the high voltage supply. A voltage drop on the supply line (usually caused by using too small supply voltage wires) will cause the operator to malfunction. Refer to the wire size chart in section 2.1.

TROUBLESHOOTING	
SYMPTON	POSSIBLE SOLUTION(S)
Operator will not run. Power LED is OFF.	<ul style="list-style-type: none"> <li>• Check that power to the operator is turned ON.</li> <li>• Transformer may be overheated. Turn power off and allow board to cool for several minutes then retest. Check for low supply power and low voltage shorts.</li> <li>• Check for 115 VAC at terminals 19 and 20. If voltage measures 0, check power. If voltage measures OK, check the terminal strip or replace the circuit board.</li> </ul>
Operator will not run. Power LED is ON.	<ul style="list-style-type: none"> <li>• If a photo-cell is used as a secondary entrapment prevention device, check to be sure that the beam is not blocked.</li> <li>• Momentarily jumper terminal 1 to terminal 5. If the input LED does not come ON, check the terminal strip or replace the circuit board. If LED does come ON, proceed to next steps.</li> <li>• Be sure that the chain is not too tight. A too tight chain may cause the operator to stall.</li> <li>• Turn power switch OFF and remove the control board.</li> <li>• Place a jumper wire from terminal 19 to terminal 18. <b>CAUTION – HIGH VOLTAGE.</b> Turn the power switch on. The motor should run. Turn the power switch off and remove the jumper.</li> <li>• Place a jumper wire from terminal 19 to terminal 17. <b>CAUTION – HIGH VOLTAGE.</b> Turn the power switch on. The motor should run in the opposite direction. Turn the power switch off and remove the jumper.</li> <li>• If the motor runs in both steps above, replace the control board. If the motor does not run, or runs in only one direction, problem can be a bad motor, motor capacitor, wire connections from the control board to the motor or a bad control board.</li> </ul>

Gate opens a short distance, then stops and reverses.	<ul style="list-style-type: none"> <li>• Disconnect the gate from the gate operator and check that the gate slides freely without any binding.</li> <li>• Re-adjust the open reverse sensitivity.</li> <li>• Replace the circuit board.</li> </ul>
Gate opens but will not close.	<ul style="list-style-type: none"> <li>• Check the input LEDs. Any ON will hold the gate open and indicates a problem with a keying device.</li> <li>• Check the secondary safety devices. Any activated will hold the gate open and indicates a problem with the safety device.</li> <li>• Check the loop detectors. Any activated can hold the gate open and indicates a problem with the loop detector or ground loop.</li> <li>• Operator may be in a "soft shutdown." Activate any keying device to determine if operator returns to normal operation.</li> <li>• If automatic close is desired, be sure SW-1, switch 2 is ON.</li> <li>• Check motor as described on previous page.</li> </ul>
Gate closes but will not open.	<ul style="list-style-type: none"> <li>• Operator may be in a "soft shutdown." Check input LED on terminal 5. If it is ON, momentarily disconnect, then re-connect the wire going to the terminal. Operator should open.</li> <li>• Check to be sure that the operator is running in the proper direction. Turn power OFF, and then back ON. Activate a keying device. Operator should run in the open direction. If operator runs in the close direction, turn power OFF and change direction switch SW-1, switch 1. Go to above section if operator now opens but will not close.</li> <li>• Be sure that the respective LED on the control board lights when the keying device connected to the respective terminal is activated. If LED does not light, momentarily place a jumper wire from terminal 1 to the input terminal being checked. If LED lights and gate opens, problem is with the keying device. If LED does not light, replace control board.</li> <li>• Check motor as described on previous page.</li> </ul>
Gate starts to close, then reverses to open.	<ul style="list-style-type: none"> <li>• Re-adjust the close reverse sensitivity.</li> <li>• Disconnect the gate from the operator and check that the gate operates freely without any binding.</li> <li>• Check the loop detector LEDs and input LEDs. Any that flash ON will cause the gate to reverse.</li> <li>• Replace the circuit board.</li> </ul>
Gate closes and then re-opens.	<ul style="list-style-type: none"> <li>• Check for any input or loop detector LEDs that are ON.</li> <li>• Check that the operator is running in the proper direction (see "gate closes but will not open" above).</li> </ul>
Entrapment alarm is sounding. Operator will not run.	<ul style="list-style-type: none"> <li>• Operator is in a "hard shutdown" condition. Reset switch must be activated to return operator to normal operation.</li> <li>• Check gate and gate hardware for any binding – correct where necessary.</li> <li>• Gate may be too heavy.</li> </ul>
Entrapment alarm sounds a short beep every 5 seconds.	<ul style="list-style-type: none"> <li>• Operator has been in a "hard shutdown" condition in excess of 5 minutes. Reset switch must be activated to return operator to normal operation.</li> </ul>
Entrapment alarm activates when power is applied and operator will not run.	<ul style="list-style-type: none"> <li>• The limit switch wire harness is not plugged into the circuit board. Check that the limit switch connector is properly plugged into P2 on the circuit board.</li> </ul>
Operator runs for 1 second and stops, two short beeps are heard.	<ul style="list-style-type: none"> <li>• There may be a problem with the current sensor on the circuit board. Replace the circuit board.</li> </ul>



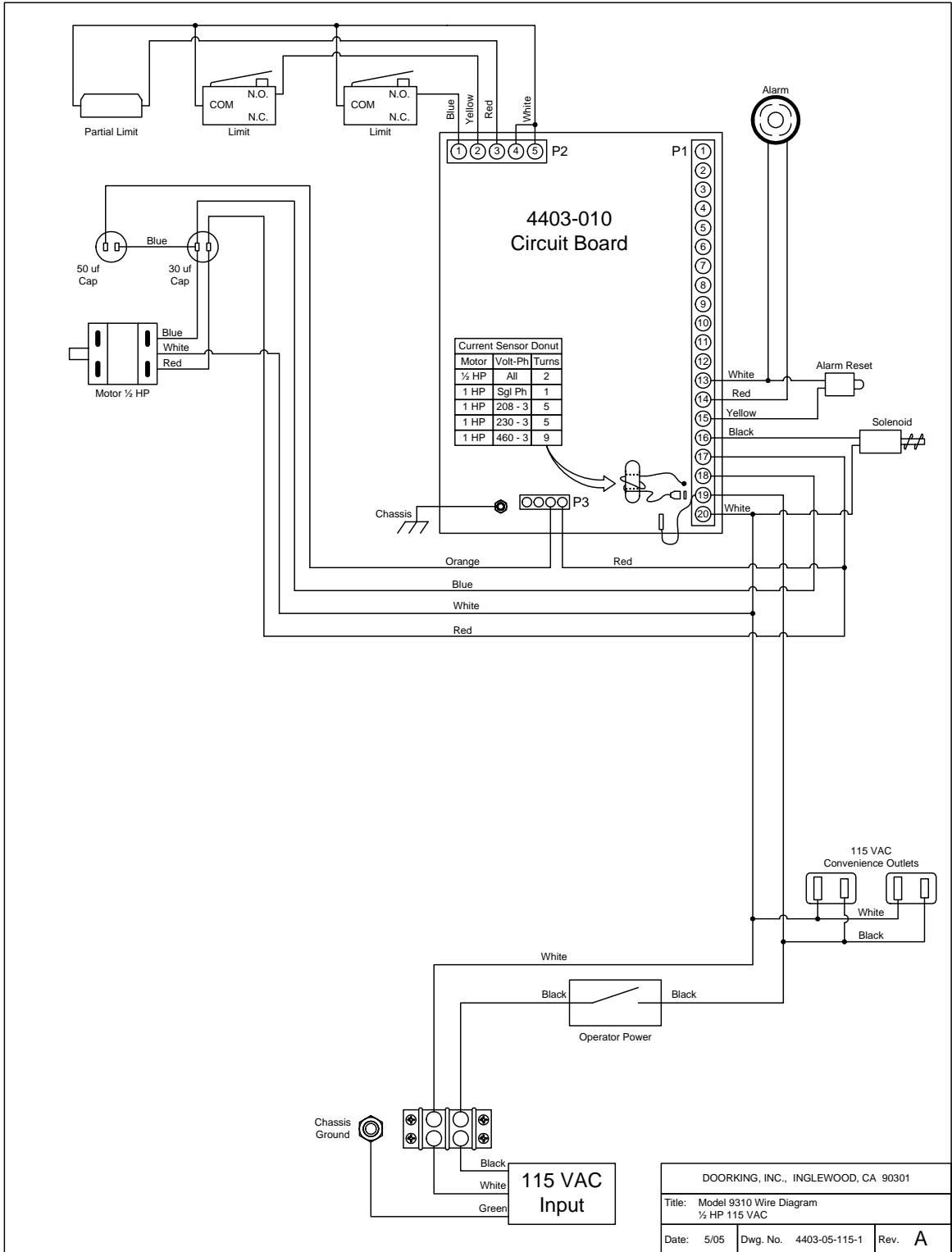

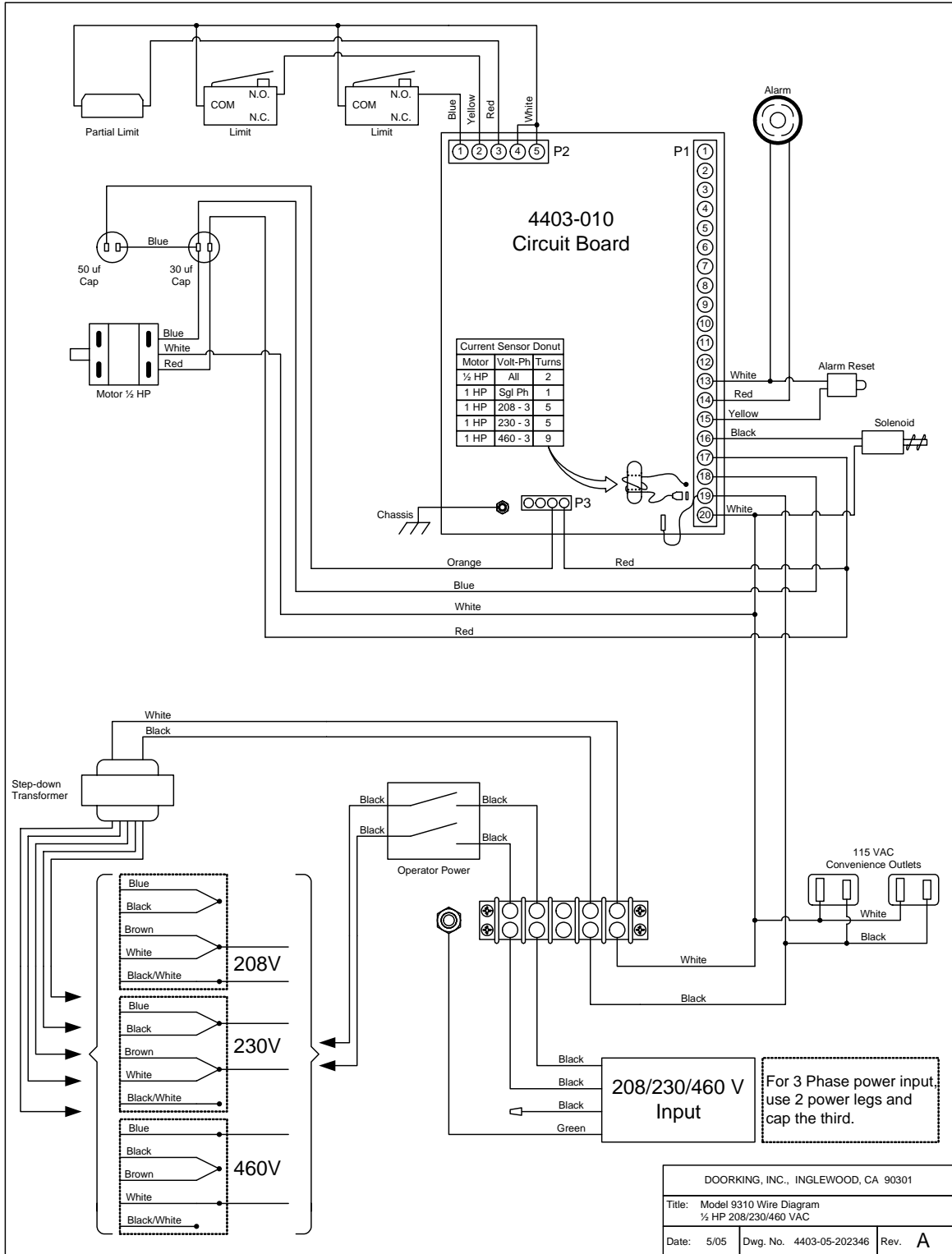

DOORKING, INC., INGLEWOOD, CA 90301  
 Title: Model 9310 Wire Diagram  
 1/2 HP 208/230/460 VAC  
 Date: 5/05 Dwg. No. 4403-05-202346 Rev. **A**

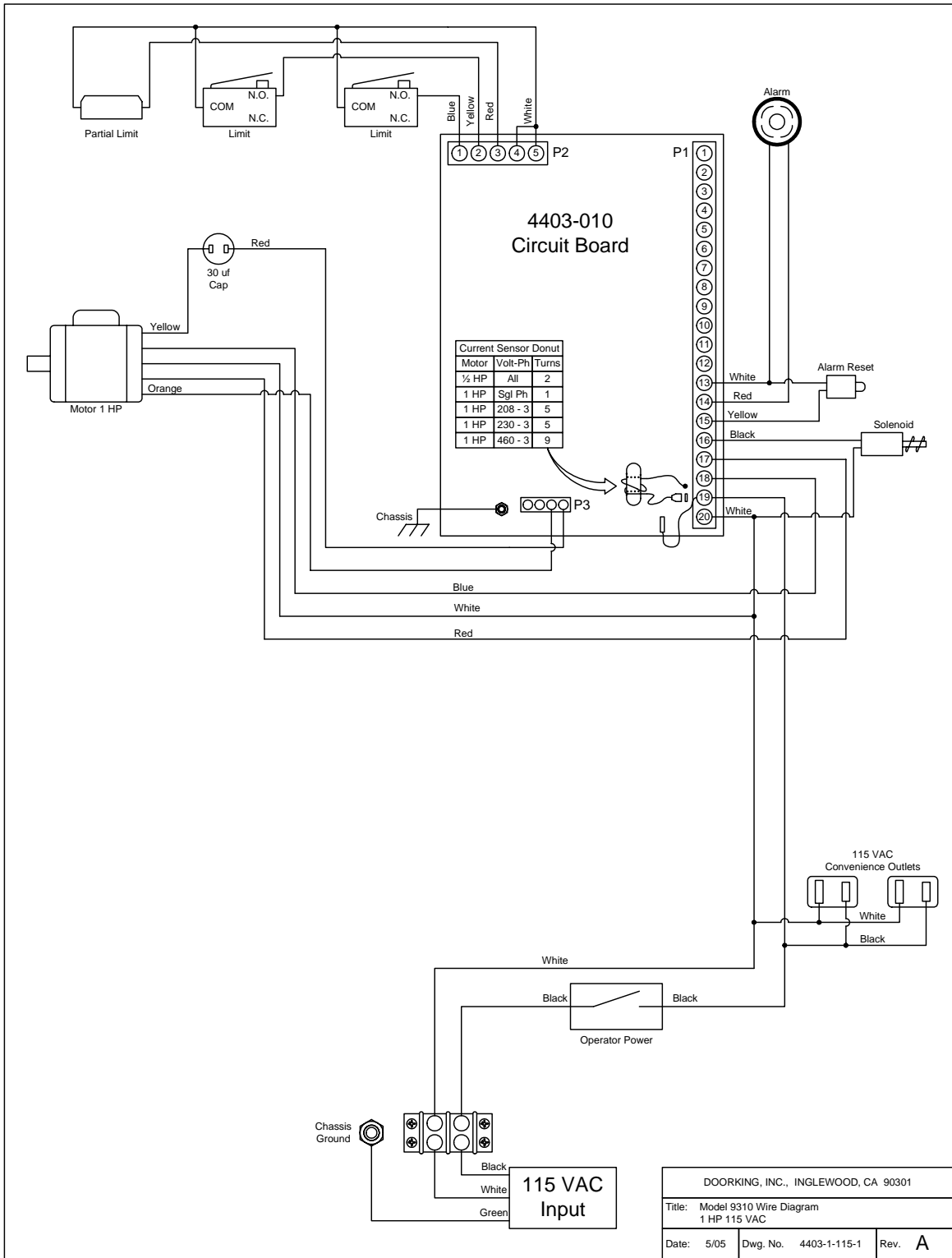

DOORKING, INC., INGLEWOOD, CA 90301

Title: Model 9310 Wire Diagram  
1 HP 115 VAC

Date: 5/05    Dwg. No. 4403-1-115-1    Rev. **A**

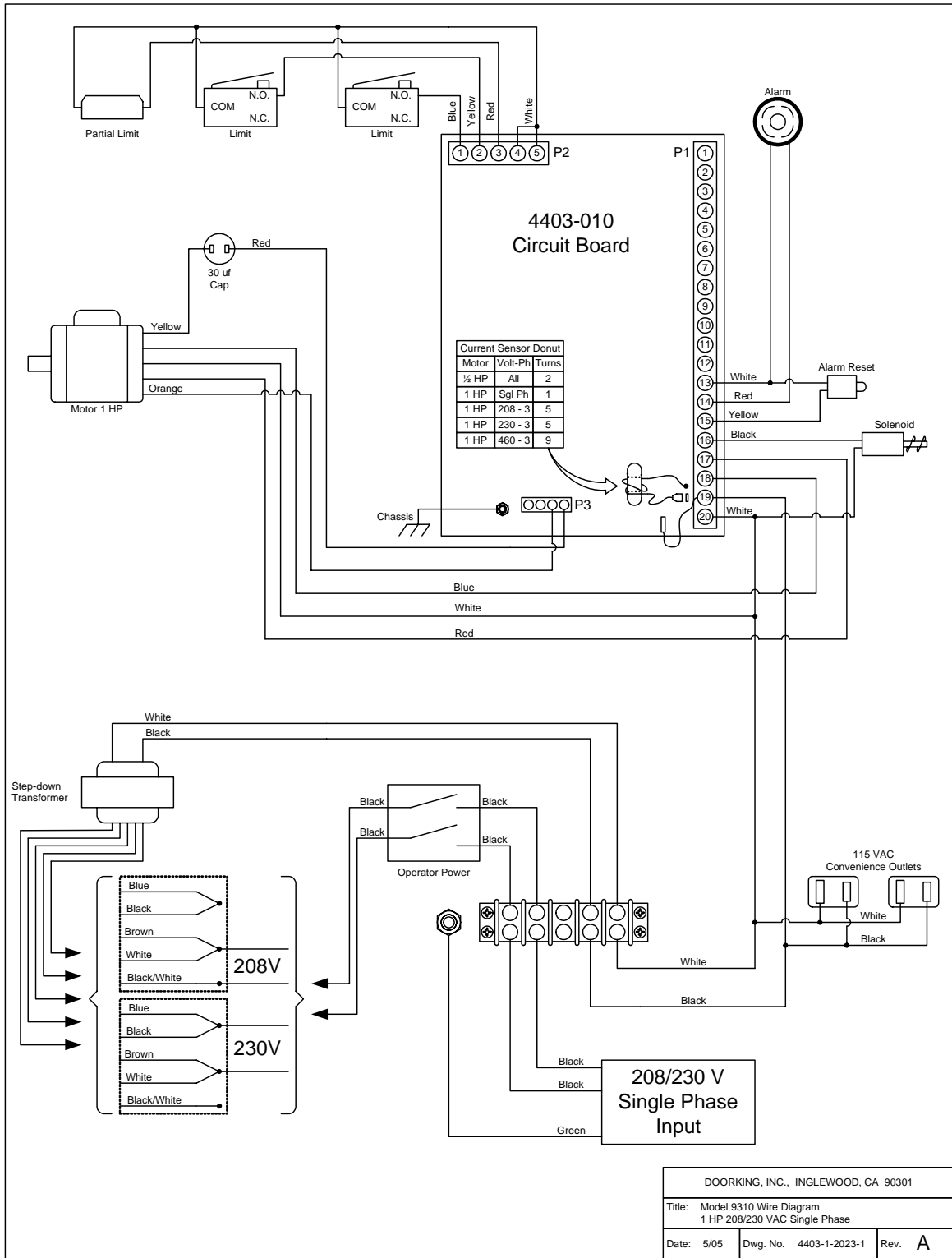

DOORKING, INC., INGLEWOOD, CA 90301

Title: Model 9310 Wire Diagram  
1 HP 208/230 VAC Single Phase

Date: 5/05    Dwg. No. 4403-1-2023-1    Rev. **A**

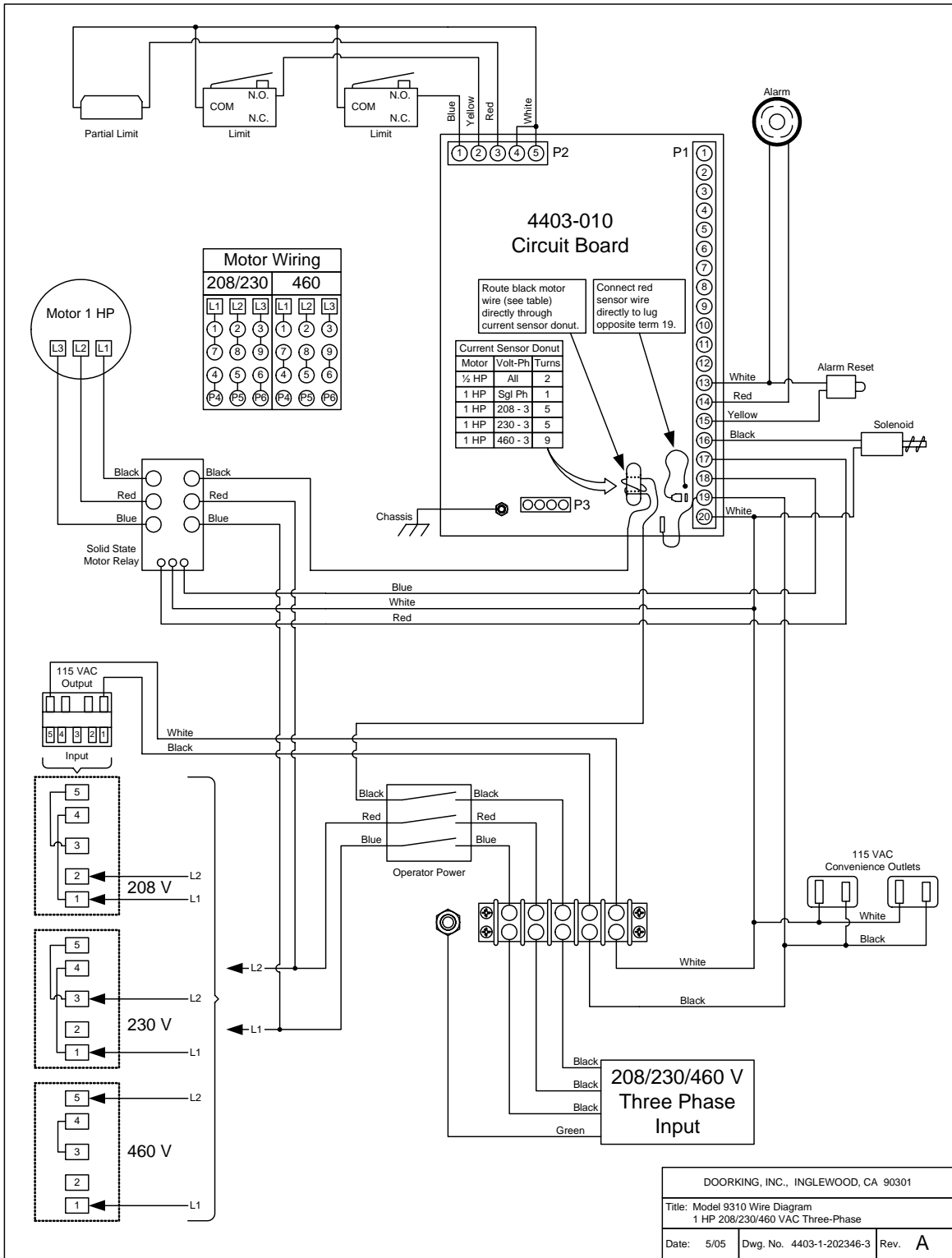

DOORKING, INC., INGLEWOOD, CA 90301

Title: Model 9310 Wire Diagram  
1 HP 208/230/460 VAC Three-Phase

Date: 5/05 Dwg. No. 4403-1-202346-3 Rev. **A**

## 5.4 Accessories

The following accessory items can be used with the model 9310 slide gate operator.

Contact Sensor	Contact sensors for use as a secondary entrapment protection device. Miller Edge, Inc. ME120, ME123, MG020, MGR20, MGS20
Photo Cell	Non-contact (photo cells) sensors for use as a secondary entrapment protection device. P/N 8080-010 – Infrared thru-beam, 165 foot sensing distance. P/N 8080-011 – Photo-reflective beam, 30 foot sensing distance.
Loop Detector	Detectors plug directly into ports on circuit board simplifying wiring. P/N 9405-010 - Single channel detector. P/N 9406-010 - Two channel detector
Loop Wire	18 AWG loop wire with XLPE insulation is ideal for ground loops. Available in 500 and 1000 foot rolls with red, blue or black insulation.
Pre-Fab Loops	Prefabricated ground loops. 24-foot circumference with 50-foot lead-in. Available in yellow, red or blue jackets. Not for use in asphalt roadways.
Loop Test Meter	Meg-ohm meter checks the integrity of ground loops. P/N 9401-045
Control Station	Three button interior and exterior control stations provide manual open-close-stop gate operation. P/N 1200-006 – Exterior P/N 1200-007 – Interior (mounts into single-gang electrical box)  Manual control station provides a single toggle for NORMAL, MOMENTARY OPEN and HOLD OPEN operation. P/N 1200-017 – Interior (mounts into single-gang electrical box)
Time Clock	7 day and 365 day time clocks can be used to automatically open gate at pre-set time and days. Compact clock fits inside the operator. P/N 2600-791 – 7-day clock. P/N 2600-795 – 365-day clock.
Surge Devices	High and low voltage surge suppressers help prevent circuit board failure caused by lightning strikes and power surges. P/N 1876-010 - High Voltage. P/N 1878-010 - Low Voltage.
Gate Scale	Use to test ft/pounds required to move gate. P/N 2600-225
Speed Bumps	Prefabricated six-foot speed bump reduces traffic speed through gate system. P/N 1610-150
Nickel Chain	Nickel plated chain. P/N 2600-443 (10 ft. #41) P/N 2600-444 (10 ft. #40)
Stainless Chain	Stainless steel chain. P/N 2600-475 (20 ft. #41)

