

# TECHNICAL DATA SHEET - Straight Column Flat Panel Ceiling Mount for 32" to 60" LCD And Flat Panel Screens

**peerless**<sup>®</sup>

MODEL: PLCM-UNL



The Straight Column Ceiling Mount offers a straight column from the ceiling attachment point to the flat panel screen. The straight column ceiling mount is ideal for sports facilities, airports, lobbies or retail environments.

### Features:

- PLCM-UNL models include a PLP-UNL adapter plate (landscape only)
- 0° to 20° adjustable tilt and 360° swivel
- Screen mounts horizontally
- Uses standard 1 1/2" – 11.5 NPT schedule 40 pipe
- Additional length can be added for lowering
- Theft-resistant security fasteners secure the screen to the mount
- Sold without ceiling plate
- Complete detailed installation instructions for wood and concrete structures

### Accessories:

- Ceiling Plate required (sold separately). Various options available. Other ceiling accessories can be ordered separately to allow mounting to I-beams, cathedral ceilings, trusses, etc.

### Dimensions:

#### **Weight:**

23.1 lb (10.5 kg)

#### **Shipping weight:**

30.3 lb (13.7 kg)

#### **Maximum Load Capacity:**

200 lb (90.7 kg)

#### **Shipping Carton dimensions:**

L = 38.0625" (967 mm)

W = 12" (305 mm)

H = 8.125" (206 mm)

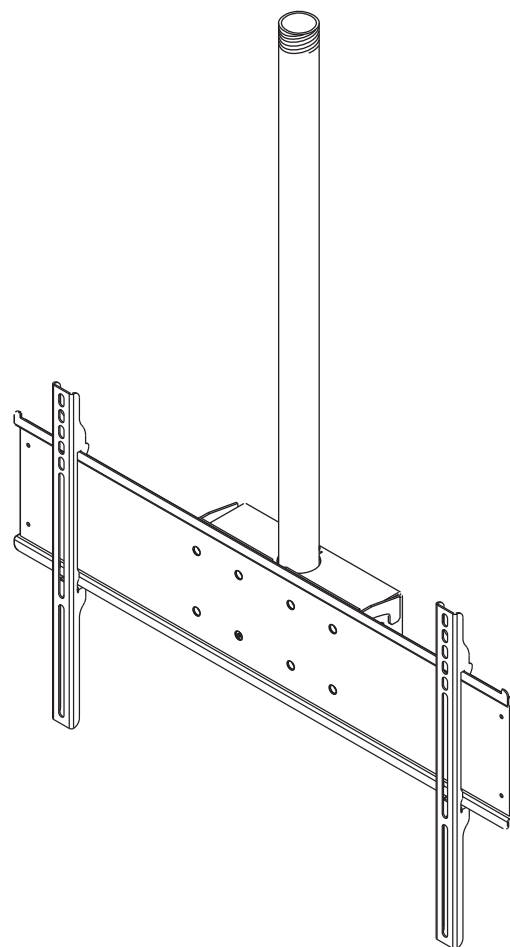

## ARCHITECTS SPECIFICATIONS

The Straight Column Flat Panel Ceiling Mount shall be a Peerless model **PLCM-UNL** and shall be mounted where indicated on the plans. It shall be constructed of heavy gauge cold rolled steel, steel tubing and finished with scratch resistant Black Fused Epoxy. It shall feature 360° swivel and 0° to 20° range of tilt. Assembly and installation shall be done according to instructions provided by the manufacturer.

#### **Peerless Industries, Inc.**

3215 W. North Ave. Melrose Park, IL 60160  
708-865-8870 800-865-2112 Fax 708-865-2941

[www.peerlessmounts.com](http://www.peerlessmounts.com)

ISSUED: 07-31-06 SHEET NO: 200-9831-3 07-08-09

© 2008, Peerless Industries, Inc. All rights reserved.

All other brand and product names are trademarks or registered trademarks of their respective owners.

TECHNICAL DATA SHEET

**MODEL: PLCM-UNL**

ALL DIMENSION = INCH  
(MM)

(UNLESS OTHERWISE SPECIFIED)

A = 34.26" (870 mm) when used with 33" (838 mm) extension  
column Landscape:  $X = A - (1/2 \text{ (height of screen)}) - 2.68" \text{ (68 mm)}$

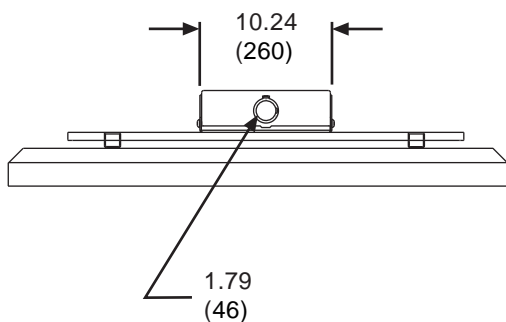

**TOP VIEW**

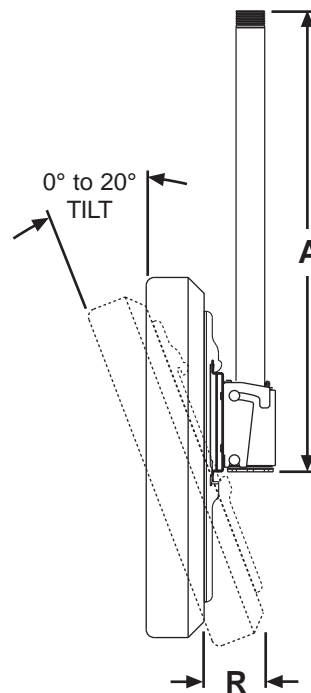

**SIDE VIEW**

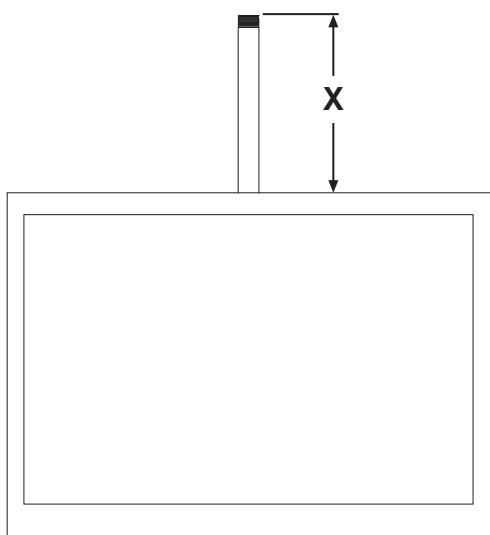

Landscape:  $X = A - (1/2 \text{ (height of screen)}) - 2.68" \text{ (68 mm)}$

**FRONT VIEW**

RANGE	
<b>R</b>	3.75 TO 5.25 (95) (133)

TECHNICAL DATA SHEET

MODEL: PLCM-UNL

ALL DIMENSION = INCH  
(MM)

(UNLESS OTHERWISE SPECIFIED)

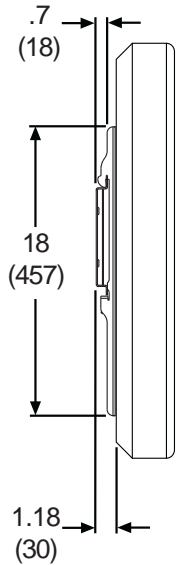

**SIDE VIEW  
WITH SHALLOW  
BRACKET**

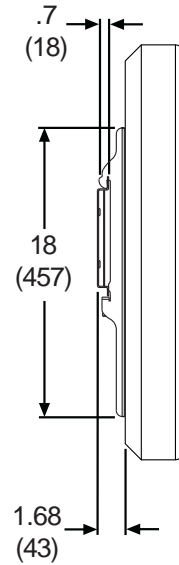

**SIDE VIEW  
WITH DEEP  
BRACKET**

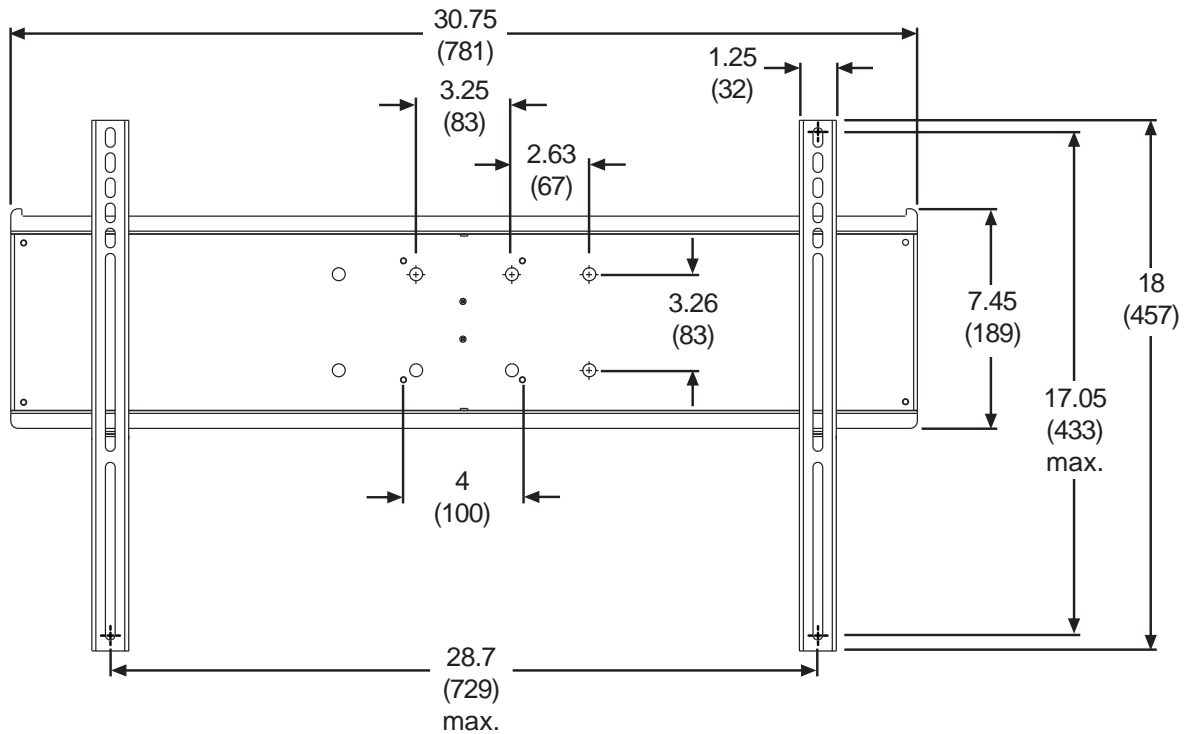

**ADAPTER BRACKET DETAIL**