

Panasonic

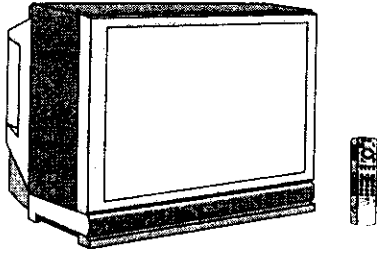

Stereo Colour Television
With TELETEXT
Operating Instructions

TX-76PW10A TX-76PW05A

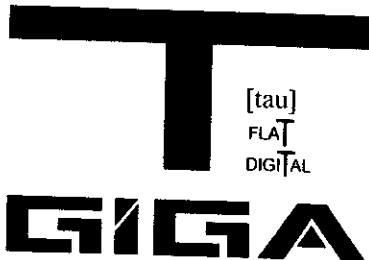
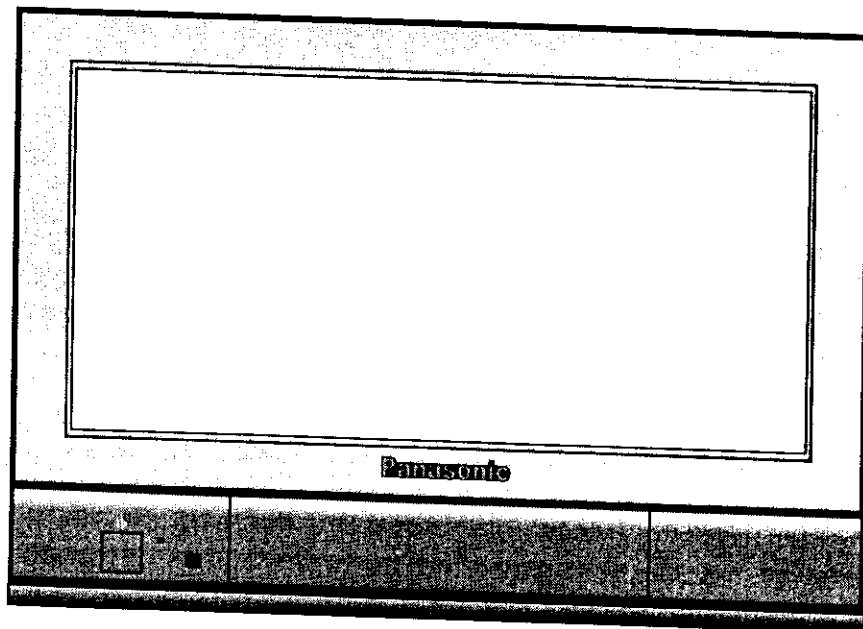

Please read these operating instructions completely before operating this set and retain the booklet for future reference.

Dolby, Pro Logic and the  symbol are trademarks of Dolby Laboratories.
Manufactured under licence from Dolby Laboratories.
Manufactured under licence from Digital Theatre Systems, Inc. US Pat. No. 5,451,942 and other world-wide patents issued and pending. "DTS" and "DTS Digital Surround" are trademarks of Digital Theatre Systems, Inc. Copyright 1996 Digital Theatre Systems, Inc. All Rights Reserved.

Dear Panasonic Customer,

Welcome to the Panasonic family. We hope that you will have many years of enjoyment from your new Colour Television.

Please retain your proof of purchase along with these operating instructions. Space has been made available on the back page of this instruction book for recording the Serial Number. The Serial Number can be found on the back cover of the set and on the packing carton.

Important Information

Programme Location Numbers

This television comes to you "factory tuned" to all the major capital city broadcast stations. Adjustments to the tuning should not be necessary. However, if you have to make adjustments, please read these instructions carefully first. Throughout this booklet "Programme Location Numbers" are referred to. *These are memory locations into which you can tune television broadcast stations.* Any television station can be tuned into any Programme Location Number.

Picture Quality

All televisions are affected by Magnetic Interference.

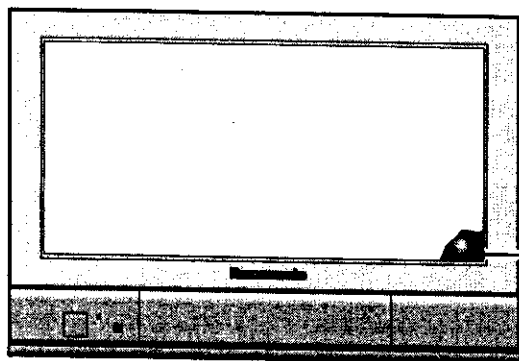

Magnetic interference may come from such things as unshielded motors, moving the TV while it is switched ON, turning off a vacuum cleaner too close to the TV, lightning strikes nearby or many other things. The interference shows up as *coloured patches* which appear while the TV is switched ON.

A typical result may look like the picture shown.

- Your Panasonic Television is designed to overcome this with the inclusion of a demagnetising (de-gaussing) function.
- To activate this feature, simply switch your Television OFF with the Power On/Off Switch (not with the remote control) for 30 minutes and then switch it back ON.
- If the television is to be left unattended for extended periods (several days or more), turn the power off to the unit. DO NOT leave in Standby mode.
- This will ensure that you enjoy the picture clarity as it was meant to be.

Refer to page 33 for operating instructions for the GEOMAGNETIC feature.

Getting Started

Connect the Aerial

The RF (Aerial) Input impedance of this television is 75Ω. If your aerial lead is 300Ω ribbon (two wires separated by a flat plastic sheet) you will require a 300Ω/75Ω Balun (not supplied) in order to connect your aerial to the television.

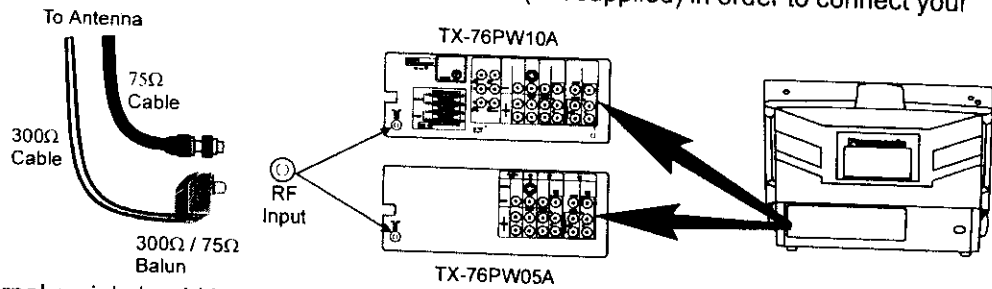

Note:

For your safety any external aerial should be installed by a reputable qualified installer and should comply with Australian Standard AS1417.1.

In New Zealand the installation should comply with International Standard IEC597-1.1.

Connect the Power Plug

The televisions are designed for the Australian Standard Mains Voltage of 240V 50Hz and the New Zealand Standard Mains Voltage of 230V 50Hz.



NOTE:

If the television is not going to be used for an extended period, remove the power plug from the wall outlet.

Turn on the Television

Push the Power Switch to turn the television ON.
Sit back and enjoy your new Panasonic television.



Battery Installation and Replacement

Place your thumb on the battery cover triangle. Apply a slight downward pressure with the thumb and slide the cover back. This allows the cover to be removed.

Insert the batteries ensuring the correct polarity. The polarity is identified by the "+" symbol on the battery and the "+" and "-" symbols on the battery compartment. The springs inside the battery compartment connect to the negative terminal of the battery.

Two "AA" size batteries



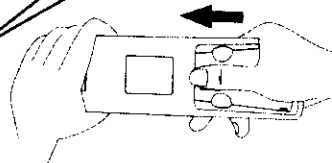
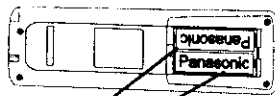
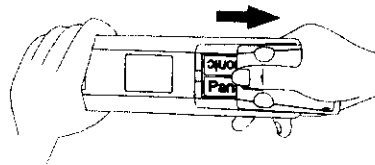







Fit the battery cover and slide it forward until it "clicks" into place.

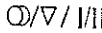

Battery Precautions

- Do Not use rechargeable batteries. Differences in size and performance may cause incorrect operation.
- Do Not mix battery types (Alkaline with zinc-carbon etc.)
- Do Not mix old and new batteries. Replace both batteries at the same time.
- Do Not attempt to recharge batteries.
- Do Not short circuit batteries.
- Do Not disassemble batteries.
- Do Not heat or burn batteries.

CONTENTS

Control Panel Buttons	6
Remote Control Television Buttons	6
STR	7
F	7
-/ \	7
+/\	7
TV/AV	7
 STANDBY	8
 PICTURE	8
 SOUND	8
 SET UP	8
 STEREO / MONO / BILINGUAL*	8
100Hz / PROGRE	8
 SURROUND	8
 ASPECT	8
MULTI PIP	8
 RECALL	8
N NORMALISATION	9
STR	9
? HELP	9
 MUTE	10
PROGRAMME NUMBER DOWN AND UP	10
 VOLUME DOWN AND UP	10
TV / AV	10
 COLOURED BUTTONS	10
STILL	10
CH SEARCH	10
0 ~ 9 DIRECT PROGRAMME NUMBER SELECTION	11
- / - - TWO DIGIT PROGRAMME NUMBER SELECTION	11
Using the On Screen Displays	12
Picture Menu Operation	13 ~ 14
MENU	13
CONTRAST, BRIGHTNESS, COLOUR, SHARPNESS, NTSC-TINT	13
COLOUR TEMPERATURE	14
PICTURE NOISE REDUCTION	14
ARTIFICIAL INTELLIGENCE	14
SCAN MODE	14
Sound Menu Operation	15 ~ 16
MENU	15
VOLUME, BASS, TREBLE, BALANCE, HEADPHONE VOL, SUBHEADPHONE	15
SUBWOOFER	16
SURROUND MENU	16
Surround Sound Operation	17 ~ 19
Set Up Menu Operation	20 ~ 21
TELETEXT	20
OFF TIMER	20
FLICKER REDUCTION	20
STROBE	20
CH COLOUR SET	20
VCR / GAME	21
TEXT SELECT	21
CHILD LOCK	21
COLOUR SYSTEM	21
TUNING MENU	21
GEOMAGNETIC	21
LANGUAGE	21

CONTENTS

Aspect Control	22
Teletext Operation	23 ~ 26
⇒ F.P. (Favourite Page)	24
≡ Set Up	24
TV/TEXT	24
STR (Store)	24
PAGE NUMBER UP & DOWN BUTTONS	24
SUB-PAGE NUMBER UP & DOWN BUTTONS	24
COLOUR CODED BUTTONS	24
i INDEX	24
HOLD	24
0 ~ 9 Page Number Buttons	24
REVEAL	24
F/T/B (Full / Top / Bottom)	25
Display Cancel	25
TIME TEXT	25
Tuning Menu	26 ~ 32
SYS Select	27
Auto Tune	28
Manual Tune	29
Tuning the Television to a VCR	29
Fine Tuning	30
Skip	30
Geomagnetic Correction	31
Remote Control VCR/LD/DVD Operation	32
Remote Control VCR/LD/DVD Buttons	33
◀◀ REWIND / REVIEW	33
□ STOP	33
■ POWER BUTTON	33
□ RECORD	33
PAUSE	33
▶ PLAY	33
▶▶ FAST FORWARD / CUE	33
VCR/LD/DVD	33
PROGRAMME NUMBER UP & DOWN / PROGRAMME SKIP	33
▶ STILL ADVANCE DISC SIDE B SELECTION	33
DISC SIDE A SELECTION	33
Manufacturers' Code Settings	34
Connecting Equipment to the TV	35 ~ 43
Front Panel Connections	35
Headphone Connections	35
Rear Panel Connections	36
Monitor Out	36
Connecting a Standard VCR to the AV Input	37
Connecting S-Video Equipment to the AV Input	37
Connecting DVD Equipment to the AV Input	37
Audio Out	38
Digital Audio In	38
External Speakers	39
Customer Information	40 ~ 44
Warnings & Cautions	40
Cleaning, Locating and Caring for the Television	41
Caring for the Remote Control	41
Troubleshooting	42
Specifications	43
Customer's Record	Back Page

Control Panel Buttons

Open the control panel door to gain access to the Television Controls Push the door at the point marked Δ to open. Push again to close.

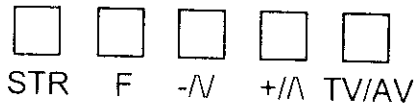
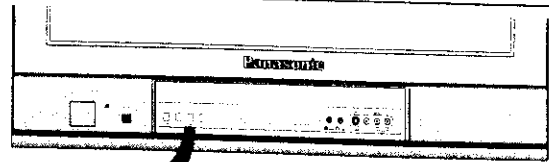

Remote Control Buttons

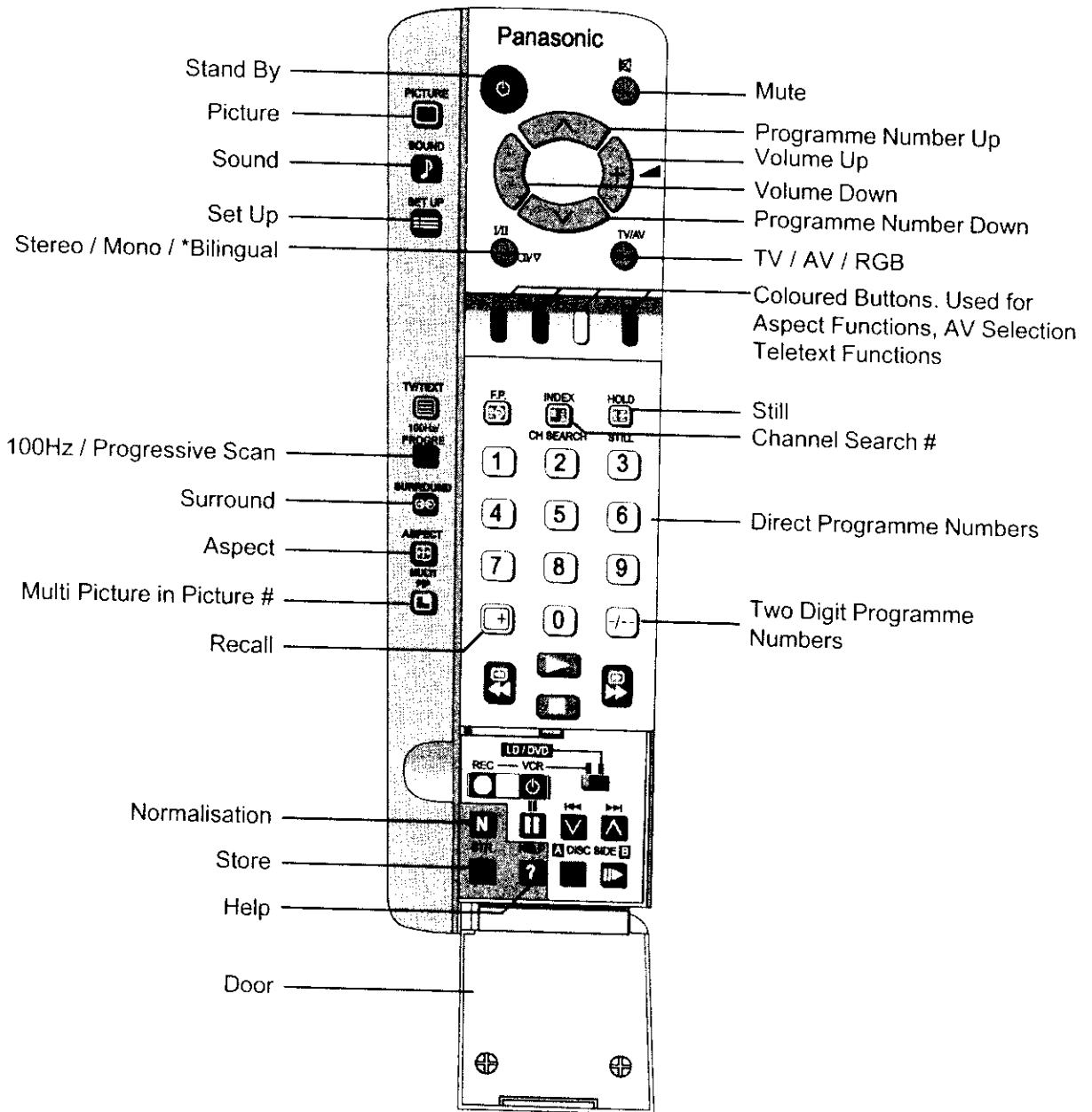

For details of TELETEXT Operation remote control operation, please refer to page 23.

For details of VCR, LD player and DVD player remote control operation, please refer to page 32.

* Bilingual broadcasting is not currently available in Australia or New Zealand.

Multi Picture In Picture button and "CH SEARCH" are not on the remote control used for the TX-76PW05A.

Television Control Panel Buttons

BUTTON

WHAT IT DOES



STR

This button is used to store tuning information and other function settings. It is also used to start the menu demonstration.

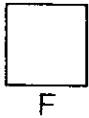

F

The F button is used to select the on screen display functions. Press the button to select the following functions sequentially.

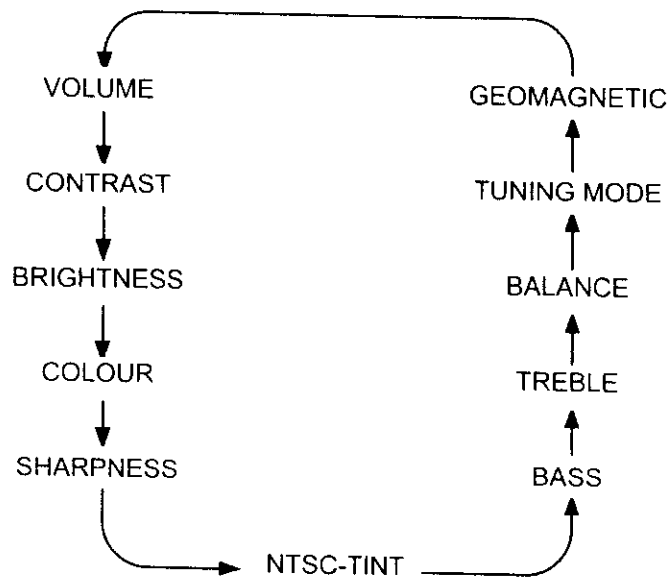

Notes:

NTSC-TINT:

Only displayed when receiving NTSC signals.

TUNING MODE:

Not displayed when in AV mode.

BALANCE:

Not displayed when SURROUND is on.



- / V

This button is used to select the next lower programme number. It is also used with the F button to adjust function settings.



+ / ^

This button is used to select the next higher programme number. It is also used with the F button to adjust function settings.



TV / AV

This button is used to switch between the TV mode and the four AV modes.

Remote Control Television Operation

BUTTON

WHAT IT DOES



STANDBY

The remote control button is used to turn the television into Standby mode. When the television is in Stand-By it is possible to turn it back on by pressing this remote control Power Button, the Programme Number UP or DOWN Button (front panel or remote control) or any of the direct Programme Number Buttons.



PICTURE

PICTURE

This button is used to select the picture menu. Please refer to page 13 for detailed operating instructions.



SOUND

SOUND

This button is used to select the sound menu. Please refer to page 15 for detailed operating instructions.



SET UP



SET UP

This button is used to select the set up menu. Please refer to page 21 for detailed operating instructions.



I/II

STEREO / MONO

Pushing the button changes the mode from Stereo () to Mono () and back again. Normally the television will detect whether the broadcast signal is Mono or Stereo and will set the mode accordingly. If the Stereo signal is weak or if the receiving conditions are not the best, it is recommended that the Mono mode be manually selected.

BILINGUAL *

This system allows two languages to be transmitted on one signal. Switching between the Main (I) and Sub (II) positions selects the desired language.

* **Note:** Bilingual sound is not currently available in Australia or New Zealand.



100Hz/
PROGRE

100Hz / PROGRE

This button allows you to change the Picture refresh setting between AUTO, 100Hz MODE and PROGRESSIVE. Please refer to SCAN MODE on page 14.



SURROUND

SURROUND

This button switches the SURROUND on and off.



ASPECT

ASPECT

This button is used to move through the different aspect options of AUTO, 4:3, ZOOM, S-ZOOM, 16:9, 14:9 and JUST. Please refer to page 22.



MULTI
PIP

MULTI PIP (TX-76PW10A only)

Pressing this button will access the Picture in Picture options. If the 4:3 aspect ratio is selected you can choose between normal, Picture And Picture and Picture Out Of Picture. All other aspect ratio settings let you choose between normal, Picture And Picture and Picture In Picture.

Notes:

The MULTI PIP picture can be another television channel or an AV input. While the On Screen Display is shown the sub-picture can be changed using the 0 ~ 9 and the "- / -" buttons, as shown on page 11.

When the On Screen Display disappears the main picture can be changed using the 0 ~ 9 and the "- / -" buttons, as shown on page 11.

MULTI PIP is not available on the TX-76PW05A.

Please refer to drawing on Page 6 for location of Remote Control Buttons.

Remote Control Television Operation

BUTTON

WHAT IT DOES

Picture In Picture Mode

Allows two pictures to be viewed at the same time. Pressing the Red button will change the position of the small picture. The Yellow button swaps between the two pictures. The Blue button removes the option bar.

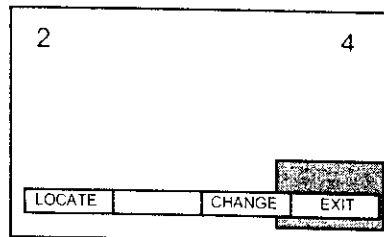

Picture Out Of Picture Mode

Allows two pictures to be viewed at the same time. The pictures will be shown side by side. The Yellow button swaps between the two pictures. The Blue button removes the option bar.

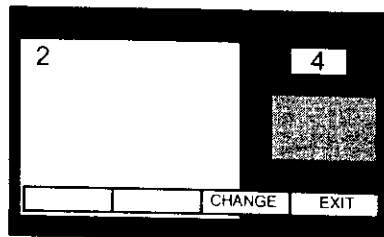

Picture And Picture Mode

Allows two pictures to be viewed at the same time. The pictures will be shown side by side. Both pictures will be the same size. The Yellow button swaps between the two pictures. The Blue button removes the option bar.

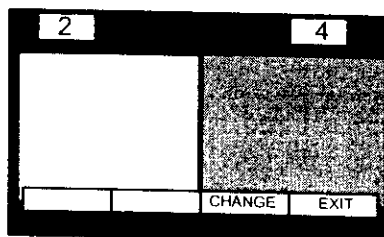

RECALL

Pressing this button will display all current active functions. The functions that can be displayed include AV Number, Programme Number, Sound Option, Picture Option, Stereo or Mono and Off-Timer setting. Pressing the button again cancels the recall function and removes the text being displayed on the screen. If the button is not pressed within about 2 seconds it automatically switches to display the Programme Number or the AV Number and the Off-Timer setting.

Pressing the button again cancels the recall function and removes the text being displayed on the screen.



NORMALISATION

The Normalisation Button is used to reset the television to factory set levels. Colour, Sharpness, Contrast, Brightness, Treble, Bass and Balance will be reset. The button will only operate if the menu is displayed on the screen.

STR



STR

The STR (Store) button is used with a number of features to store settings after adjustments have been made or options have been set. It is also used in TELETEXT and tuning functions.

HELP



HELP

Pressing this button displays on screen instructions on how to adjust various settings and how to connect external equipment. Press the HELP button and select one of the options. Please refer to page 12.

Remote Control Television Operation

BUTTON

WHAT IT DOES



SOUND MUTE

Pressing this button reduces the sound from the television to nil. Pressing the button again returns the sound to the original setting. Pressing the Volume Up (+) or Down (-) will also restore the volume level setting.



PROGRAMME NUMBER UP & DOWN

Pressing this button selects the next higher (\wedge) or lower (\vee) Programme Number in sequence. Programme Numbers which have been "Skipped" (See page 32) will be bypassed when this button is used.



VOLUME DOWN & UP

This button is used to increase (+) or decrease (-) the volume output level from the television.



TV / AV

Pressing the TV/AV Button will cycle between TV, the current AV Input, RGB and back to TV. While the AV indicator is still on screen the different AV inputs can be selected using the coloured buttons.

RED



AV1

GREEN



AV2

YELLOW



AV3

BLUE



AV4



COLOURED BUTTONS

These buttons are used for:

- selecting different aspect ratios
- selecting different AV inputs
- teletext functions



Still

Press this button to freeze the picture on the screen. Press it again to return to normal viewing.

Please refer to drawing on Page 6 for location of Remote Control Buttons.

Remote Control Television Operation

BUTTON

WHAT IT DOES



CHANNEL SEARCH (TX-76PW10A only)

This option is used to show freeze frames of the programmes being broadcast on all the stored channels. The images are displayed clockwise around the edge of the screen starting from the top left corner. The current programme is displayed in the centre of the screen. When the display gets back to the top left corner it will overwrite the first picture with the next one in series.

The display will continue to change until either the  button is pressed to

pause or  is pressed to exit the feature.

The Red button is used to select each programme in turn. The green button is used to swap the main display between the current programme and the one selected by the red button. The Blue button returns to normal viewing.

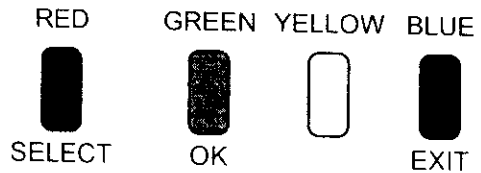
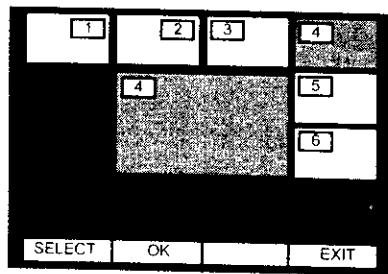

0 ~ 9

DIRECT PROGRAMME NUMBER SELECTION

Single Digit Programme Numbers (0 to 9) can be accessed directly by pressing the corresponding number on the Remote Control Transmitter.

- / - -

TWO DIGIT PROGRAMME NUMBER SELECTION

To directly access Programme Numbers 10 to 99, press the "- / - -" Button followed by the two digits required. For example, to select Programme Number 12:

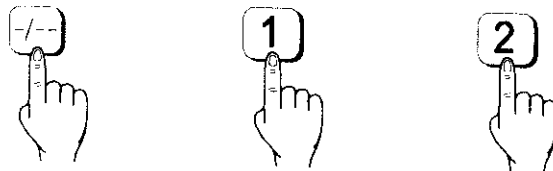

The On-Screen display will be as shown:

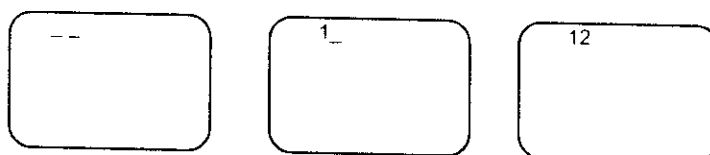

Please refer to drawing on Page 6 for location of Remote Control Buttons.

Using The On Screen Displays

Many features available on this TV can be accessed via the On Screen Display menu system. Use the remote control to access and adjust features as required.

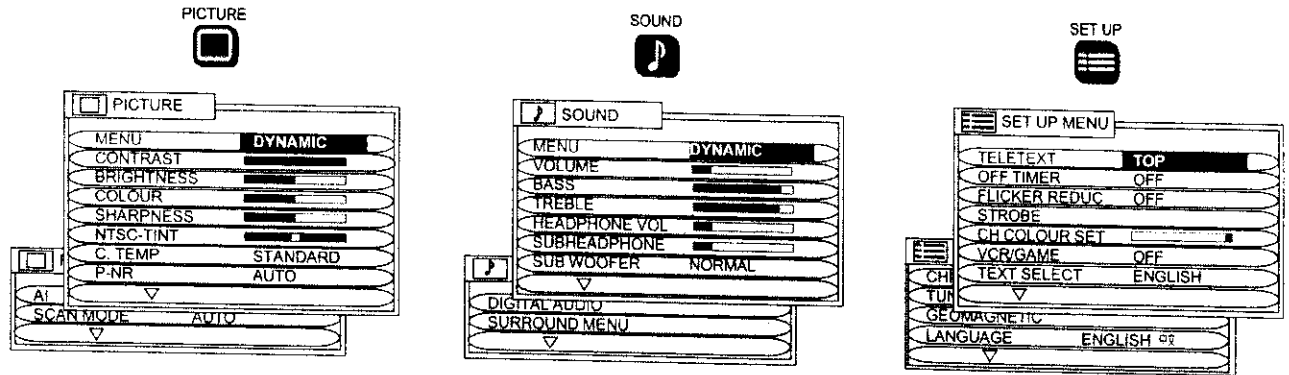

An on screen help box is displayed whenever a menu is displayed on the TV. This help box indicates which keys on the remote control are used to navigate the menu shown. See above for descriptions of button functions.

Note:





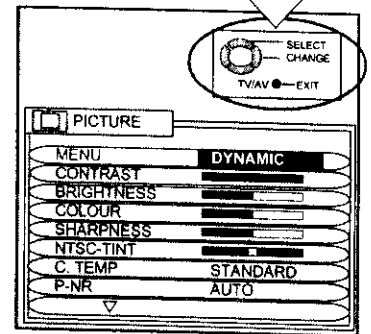

The help box is not shown in the menu pictures in this manual due to space limitations.

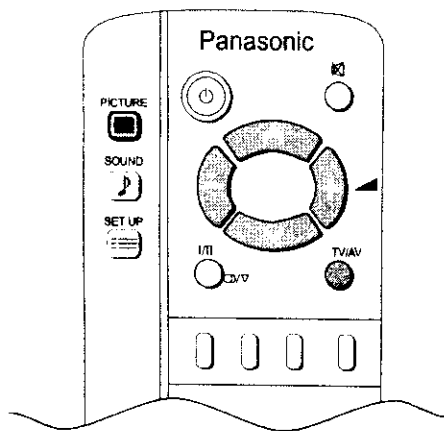
ON SCREEN HELP
Instruction box





Picture Menu Operation



- 1 Push the PICTURE button. 
 - 2 Select the option menu using  or .
 - 3 Adjust the chosen option using  or .
- Push the TV/AV  at any time to return to watching TV.

MENU





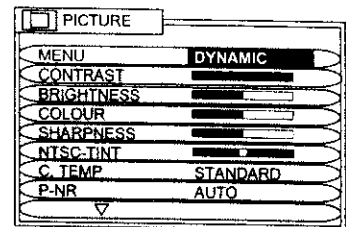





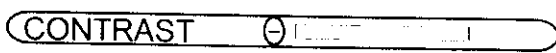

The MENU control allows you to change the Picture setting between Dynamic, Standard and Soft.

Use the  or  buttons to switch between settings.

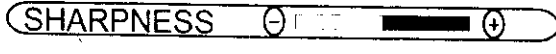

- DYNAMIC** For viewing in brightly lit rooms. This menu selects higher than normal levels of Brightness and Contrast.
- STANDARD** For viewing in normal (evening lighting) environments. This menu selects the normal levels of Brightness and Contrast.
- SOFT** For viewing in a dark room. This menu selects reduced levels of Brightness and Contrast.

CONTRAST, BRIGHTNESS, COLOUR, SHARPNESS, NTSC-TINT

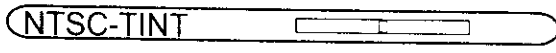
Item	Effect	Function	On-Screen Indication
CONTRAST	  Less More	Adjust for best picture contrast.	
BRIGHTNESS	  Darker Brighter	Adjust for easier viewing of dark pictures such as night scenes.	
COLOUR	  Less More	Adjust the level of colour in the picture.	
SHARPNESS	  Softer Sharper	Adjust to make the picture sharper or softer.	
NTSC-TINT	  Redish Greenish	Adjust for best skin tones.	



Notes:

1. You can change the level for each function (Contrast, Brightness, Colour, Sharpness and NTSC-Tint) for each picture menu option.
2. Picture menu levels can be set for TV, AV1, AV2, AV3 and AV4 modes.
3. NTSC-TINT only appears when the TV is receiving NTSC signals.
4. Only CONTRAST will be displayed in TELETEXT mode.

Picture Menu Operation

C. TEMP

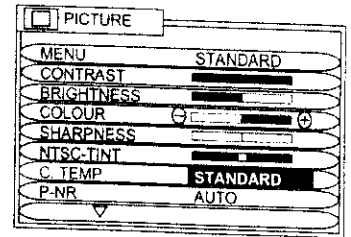

The C. TEMP (Colour Temperature) control allows you to change the White balance setting between Standard, Warm and Cool.

Use the  or  buttons to switch between settings.



P-NR

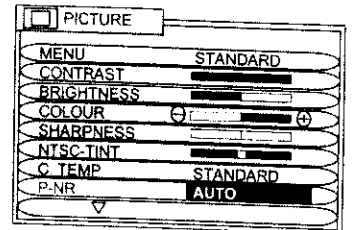

The P-NR (Picture Noise Reduction) system is designed to reduce picture noise during poor quality reception conditions. Pushing the left or right buttons will change the setting between OFF, STRONG, WEAK and AUTO.

Use the  or  buttons to switch between settings.



AI

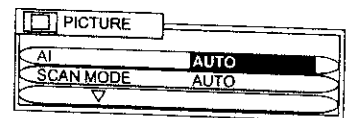

When the AI (Artificial Intelligence) is turned on it continually and precisely detects fine differences in the picture signal. It also detects the differences in the brightness, black level and contrast levels.

Use the  or  buttons to switch the AI on or off.



SCAN MODE

The SCAN MODE control allows you to change the Picture refresh setting between AUTO, 100Hz MODE and PROGRESSIVE.

Use the  or  buttons to switch between settings.

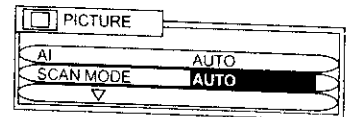

AUTO

The TV software will select the best mode for the signal being viewed.

100Hz MODE

100Hz will give a steady picture for most signals.

PROGRESSIVE

Recommended when receiving NTSC signals.

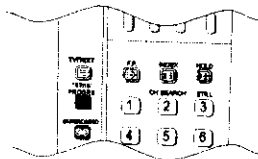



Switching is also possible using the  button on the remote control.

Note:

We recommend that you set the SCAN MODE to PROGRESSIVE when viewing a PAL 60 or NTSC transmission. When viewing a PAL transmission (other than PAL 60) with the SCAN MODE set to PROGRESSIVE, the screen will flicker. This is not a fault.





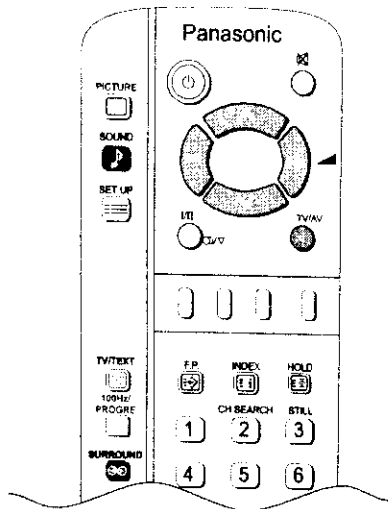

Normalisation

Pressing the Normal () Button on the remote control, when the Picture Menu is displayed will return all picture settings to the factory preset levels. This is called "Normalisation".

Normalisation *will not* occur if the Picture Menu is not displayed when the Normal () Button is pressed.

Sound Menu Operation





- 1 Push the SOUND button .
 - 2 Move to the option menu using  or .
 - 3 Adjust the chosen option using  or .
- Push  at any time to return to watching TV.

Some features are only available with the SURROUND feature switched off.

Push the  button to switch the SURROUND on or off.

MENU

The MENU control allows you to change the Sound setting between Dynamic, Standard and Soft.

Use the  or  buttons to switch between settings.

DYNAMIC

Amplifies the low frequencies and outputs optimum sound. Used for music programmes.











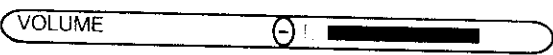

STANDARD

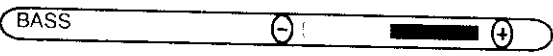
For normal use.

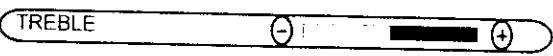
SOFT

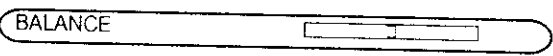
Human voices (middle pitch sounds) will be more clear. Used for News broadcasts etc.

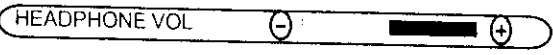
VOLUME, BASS, TREBLE, BALANCE, HEADPHONE VOL.

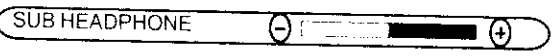
Item	Effect	Function	On-Screen Indication
VOLUME	  Quieter Louder	Adjusts the output volume.	
BASS	  Cut Boost	Used to boost or cut low frequency sounds.	
TREBLE	  Cut Boost	Used to boost or cut high frequency sounds.	
BALANCE	  Left SP Right SP	Adjusts the sound balance between the left and right speakers.	
HEADPHONE VOL	  Quieter Louder	Adjust for output volume for the headphones.	
SUB HEADPHONE (TX-76PW10A only)	  Quieter Louder	Adjust for output volume for the headphones.	

Notes:

1. You can change the level for each function (Bass and Treble) for each sound menu option.
2. Sound menu levels can be set for TV, AV1, AV2, AV3 and AV4 modes.
3. BALANCE is not displayed when SURROUND is on.

Sound Menu Operation

SUBWOOFER

This function allows you to switch the SUBWOOFER between OFF, NORMAL and FULL modes.

Use the or buttons to switch between settings.

OFF

Turns the SUBWOOFER off.

NORMAL

Provides a mid-level bass effect.

FULL

Provides enhanced bass effect.

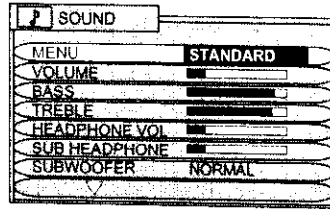

TX-76PW10A

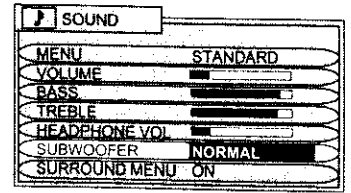

TX-76PW05A

DIGITAL AUDIO (TX76PW10A only)

Use the or buttons to switch between settings. (OFF, AV1, AV2, AV3 and AV4)
If you do not have a digital audio input, set the option to OFF.

If you have a digital audio input from external equipment such as a DVD player switch the digital audio to the corresponding AV input. For example if the DVD is connected to AV2, set the digital audio to AV2.

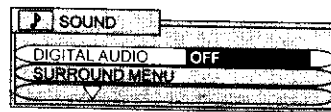

SURROUND MENU

This function allows you to switch the Surround Sound on or off (TX-76PW05A) or select the Surround options (TX-76PW10A).

Use the or buttons to switch between settings.

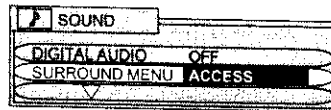

TX-76PW10A

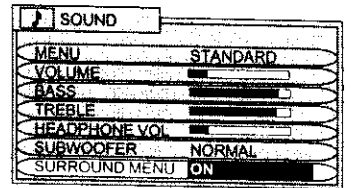

TX-76PW05A

Normalisation

Pressing the Normal () Button on the remote control, when the Sound Menu is displayed will return all sound settings to the factory preset levels. This is called "Normalisation".

Normalisation *will not* occur if the Sound Menu is not displayed when the Normal () Button is pressed.

Surround Sound Operation (TX-76PW10A only)

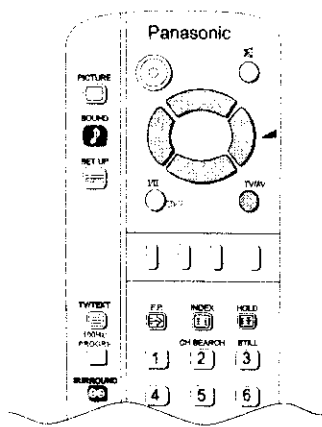

Push the Surround () to confirm that the Surround feature is On. If the on screen message that appears indicates Surround is Off, Push again to turn the feature On.

Note: If Surround is Off, the sound output is two channel (ie: left and right) stereo or mono.

- 1 Push the SOUND () button.
- 2 Select to Surround menu by using or .
- 3 Access Surround menu by using or .
- 4 Move to chose menu option by using or .
- 5 Adjust chosen option or access chosen menu by using or .

Push to go back to watching TV.

If a DTS / Dolby Digital input is detected the Surround menu options instantly change - Surround mode is not available. (The DVD output must be labelled "DTS" or "Dolby Digital"). Ensure that the Digital Audio option in the SOUND menu is set to the correct AV input (see page 42). A message displayed in the centre of the screen shows whether the signal is DTS or Dolby Digital, and gives a code indicating which channels are detected (see table to the right). Subwoofer output is not listed; if a subwoofer channels is detected then its contents are output.

Code	Front outputs			Rear surround outputs	
	Left	Right	Centre	Left	Right
1+1	Dual mono output				
1/0	Mono output				
2/0	✓	✓			
3/0	✓	✓	✓		
2/1	✓	✓		Mono output	
3/1	✓	✓	✓	Mono output	
2/2	✓	✓		✓	✓
3/2	✓	✓	✓	✓	✓

VOLUME The volume adjustment sets the overall Surround output volume.

SURROUND MODE When a DTS/ Dolby Digital input is not detected this option is shown. Choose between PRO LOGIC and SIMULATED. The mode chosen here dictates the next menu option.

SPEAKER SETTING/ SIMULATED If a DTS / Dolby Digital input is detected, or if Pro Logic is selected in Surround mode, this menu option is Speaker setting, allowing selection of NORMAL, PHANTOM or 3 STEREO modes, as described on page 19. If Simulated is selected in Surround mode, this menu option is Simulated setting, allowing selection of DISCO, MOVIE or STADIUM modes, as described on page 19.

SPEAKER Allows adjustment of the volume for each speaker, as LEVEL described on page 19.

FRONT DISTANCE Allows setting of the distance from the listening position to the front speakers. Distances or 1, 2, 3, 4, 5, 6, 7 or 8M can be selected.

REAR DISTANCE Allows setting of the distance from the listening position to the rear speakers. If the rear surround speakers are closer to you than the centre speaker, you may hear "dialogue leakage" from the rear surround speakers. It may be necessary to reduce the volume of the rear speakers. Distances or 1, 2, 3, 4, 5, 6, 7 or 8M can be selected.

INTERNAL SPEAKER If you do not have an external centre speaker connected, set to On. If you wish to connect an external centre speaker then switch Off, see page 43 for connection details.

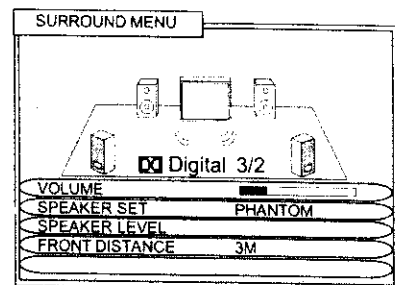

If a DTS / Dolby Digital Input is detected, the Surround menu is as shown above. This does not occur if the DVD output is PCM.

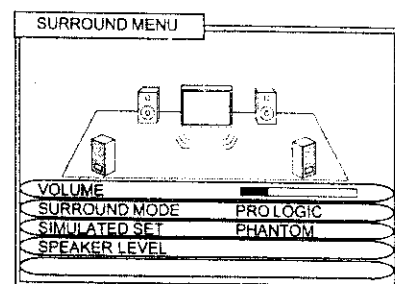

If no DTS / Dolby Digital input is detected, Surround mode appears as a menu option.

Surround Sound Operation (TX-76PW10A only)

Surround Sound Systems

Stereo reproduction normally uses left and right speakers, but Digital Theater System and Pro Logic Surround go further, adding a centre and other channels so you are immersed in sound and special effects.

Digital Theater Systems (DTS) / Dolby Digital

Both DTS and Dolby Digital split soundtrack information into 6 separate channels of sound which are output through the speaker setup: five full range channels (left, center, right, left surround, right surround) and a '0.1' (i.e.: limited range) bass channel. This gives you superb sound quality from DTS / Dolby Digital encoded tracks when a compatible speaker system is connected to your TV. Most dialogue comes from the centre channel, which enhances dialogue and focuses it so it seems to come from the action on screen. The separate rear left and right channels give a dramatic sense of space, with sounds travelling in all directions between front, centre and rear channel speakers (e.g.: a rocket going overhead starts behind you to the left and explodes in front of you to the right). The '0.1' Low Frequency Effects (LFE) channel gives impact to bass sounds and to special effects more felt than heard (e.g.: the thud of a dinosaur footfall or the rumble of thunder). While DTS and Dolby Digital are both high quality, '5.1' channel surround systems, the two systems differ in how they break down and store sound information. They also differ in how they work with existing speaker setups. Dolby Digital has been designed to be backwardly compatible with Dolby Pro Logic and conventional stereo setups. DTS on the other hand, focuses on the high quality, 5.1 channel surround output choosing not to develop backward compatibility with existing sound systems.

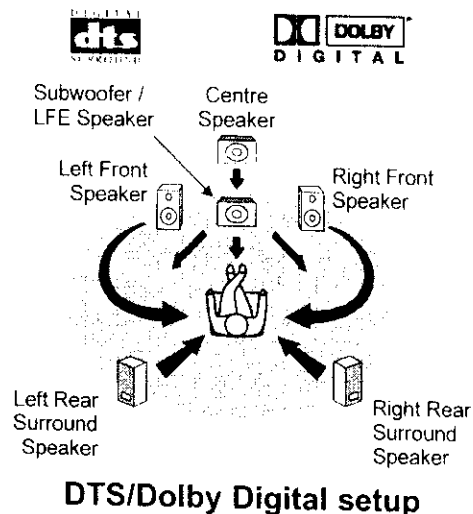

Note:

External equipment is usually connected to the TV via one of the AV terminals to provide pictures and sound (e.g. a VCR player connected to AV2). To receive a DTS or Dolby Digital encoded soundtrack from compatible equipment (e.g.: a DVD player, a set top box) you will also need to connect an optical or coaxial cable to one of the TV's digital audio sockets. See page 42 for connection details. Also see the Digital Audio option in the SOUND menu, page 16.

Dolby Pro Logic

Dolby Pro Logic surround uses four channels of sound: left, right, centre and a rear channel giving excellent reproduction of Pro Logic encoded tracks when a compatible speaker system is connected to your TV. Most dialogue comes from the centre channel, which enhances dialogue and focuses it so it seems to come from the action on screen. The rear channel is used to immerse you in atmosphere and special effects, the same output is sent to both rear speakers.

As with Dolby Digital, Pro Logic is backwardly compatible with a conventional stereo speaker setup.

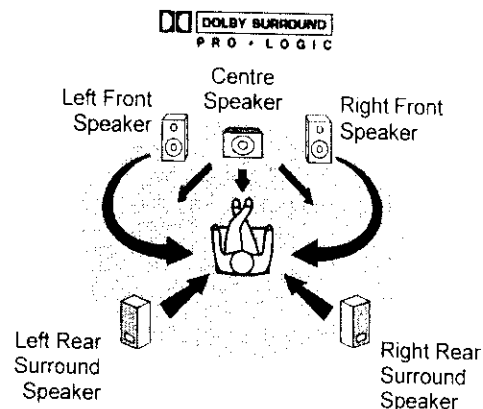

Note:

To get Pro Logic information from Pro-Logic encoded TV programmes; you must be able to receive stereo transmissions. If stereo transmissions are not transmitted in your area then the Pro Logic information will not be present on TV transmissions and Pro Logic decoding will only produce a centre channel output.

Surround Sound Operation (TX-76PW10A only)

Dolby Digital and Pro Logic modes

For Dolby Digital input or Pro Logic selected in Surround mode, the following three modes of operation are available as the speaker setting: Normal, Phantom, 3 Stereo.

Normal If front and rear speakers are connected, use Normal mode. Centre speaker information will be produced by the TV's internal left and right speakers. With a DTS/ Dolby Digital 5.1 input, the LFE speaker information is produced by the TV's internal subwoofer. If the internal speaker is switched off (see page 17) and an external centre speaker used, the speaker must be connected using RCA cables, via an external amplifier (otherwise it will not output any sound). See page 42 for connection details.

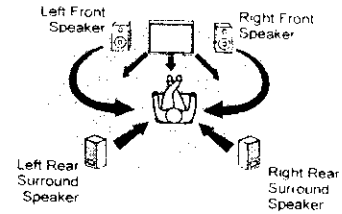

Phantom If front left and right speakers are not connected, use Phantom mode. Left, right, and centre information will now be produced by the TV speakers. If you choose to use this mode with the internal speaker switched off and front left and right speakers connected, these must be connected using RCA cables, via an external amplifier (otherwise they will not output any sound). See page 42 for connection details.

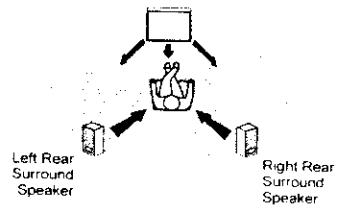

3 Stereo This is the best mode to use if rear speakers are not connected. When using this mode, the surround information is redirected to the front left and right speakers. Centre information is output by the TV's internal speakers. If the internal speaker is switched off (see page 17) and an external centre speaker used, it must be connected to the TV using RCA cables, via an external amplifier (otherwise it will not output any sound). See page 42 for connection details.

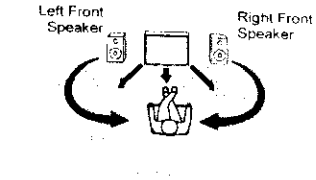

Simulated Mode

Simulated modes allow various types of surround effects to be produced by mimicking both the direct sound, as heard by the audience, and the sound reflected back from the surrounding walls, ceiling and floor in places such as a discos, stadiums etc. There are three different effects to choose from, each reflecting a different atmosphere:

Setting	Appropriate sources	Effect
DISCO	Disco, dance or jazz music	A crowded nightclub
MOVIE	All movies or music software recorded without Dolby Surround	Simulates a surround sound recording
STADIUM	Any live sports occasion	A packed sports stadium

Speaker Level Setup

The speaker output levels from the different options, e.g.: Left, Centre, Right, Rear right and Rear left, should be adjusted from your usual listening position, to obtain the best results. The level can be set using either the TV sound or the test signal provided. Pushing the SURROUND button switches between the test signal and TV sound.





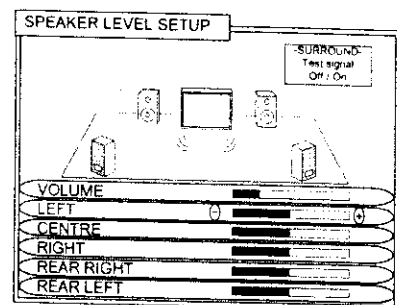

Notes:

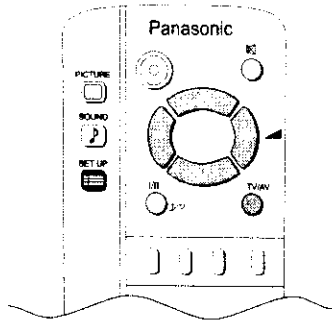
The adjustment menu available will vary according to the mode chosen. If you have a DTS / Dolby Digital 5.1 input, and are using the internal subwoofer to produce the LFE information, you can change the LFE volume by altering the Subwoofer setting in the SOUND menu. (see page 16). When using external stereo equipment it is advisable to set the speaker levels to the midpoint position.





Set Up Menu Operation



- 1 Push the SET UP button .
 - 2 Move to the option menu using  or .
 - 3 Adjust the chosen option using  or .
- Push  at any time to return to watching TV.

TELETEXT

This control allows you to change between LIST and TOP or FASTEXT modes.

Use the  or  buttons to switch between settings.

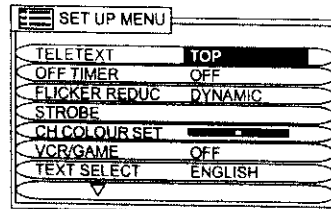

AUSTRALIA

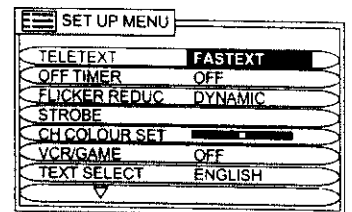



NEW ZEALAND

TOP mode is the current preferred method in Australia.
FASTEXT mode is the current preferred method in New Zealand.

OFF TIMER

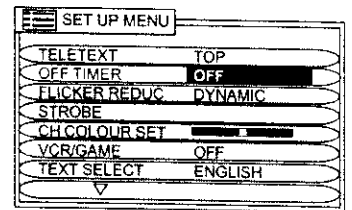

The Off-Timer turns the television off after a period of time chosen by you. The timer settings (in minutes) are OFF, 15, 30, 45, 60, 75, 90.

Use the  or  buttons to switch between settings.



FLICKER REDUCTION

This lets you control any unwanted picture movement. The settings are OFF, NORMAL and DYNAMIC.

Use the  or  buttons to switch between settings.

- OFF No flicker reduction is applied.
- NORMAL Used to correct picture movement or if slight ghosting occurs when using DYNAMIC.
- DYNAMIC Activates motion compensation to smooth the image and gets rid of picture movement.

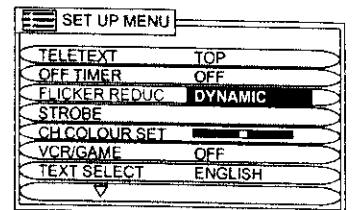

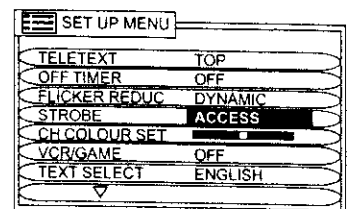

STROBE

Lets you take a series of freeze-frame photos of a piece of action such as the finish or a race etc.



CH COLOUR SET

Colour density varying between broadcast channels can be adjusted to three levels for each channel received.

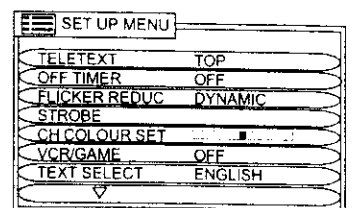

Use the  or  buttons to switch between settings.



Set Up Menu Operation

VCR/GAME

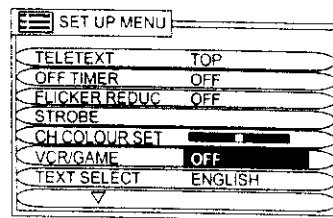

Reproduction of irregular signals such as certain video games or some rental video tapes may be improved by turning the VCR/GAME feature On.

Use the  or  buttons to switch VCR/GAME on or off.



TEXT SELECT

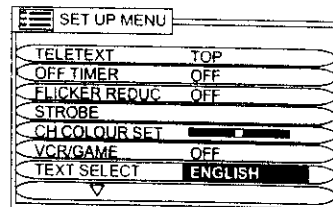

Select the character set so that all characters needed are available for text on teletext pages. The languages available are ENGLISH, CIS and E.EUROPE.

Use the  or  buttons to switch between languages.



CHILD LOCK

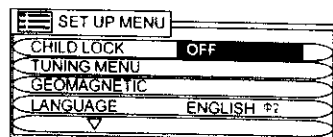

CHILD LOCK allows you to "lock out" a channel to prevent a child from watching or hearing a particular programme. Select the channel or AV to be locked before pressing the SET UP button.

Use the  or  buttons to switch the CHILD LOCK on or off.



COLOUR SYSTEM



COLOUR SYSTEM is only available in AV mode. This option allows you to select the correct colour system for the signal being received. If a clear picture with correct colours cannot be obtained, a change to the Colour System may improve the picture. The settings are AUTO, PAL, NTSC4.43 and NTSC3.58. The Australian and New Zealand colour system is PAL.

Use the  or  buttons to switch between settings.

Note: PAL and NTSC3.58 are different colour signal broadcast transmission systems applicable to differing countries. NTSC4.43 is a system used in special VCRs to playback NTSC recorded tapes on a PAL television.

TUNING MENU

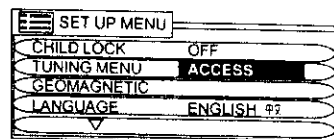

This provides access to many other features including system select and tuning options.

Use the  or  buttons to access the TUNING MENU.



GEOMAGNETIC

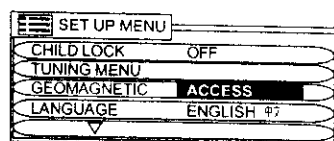

If you notice a slight tilt in the picture or if there are coloured patches at the corners of the screen, use this feature to eliminate them. Refer to page 31.

Use the  or  buttons to access the GEOMAGNETIC Adjustment Menu.



LANGUAGE

When you first install the TV the On Screen Display language is set to English. The language can also be set to Chinese.

Use the  or  buttons to switch between languages.

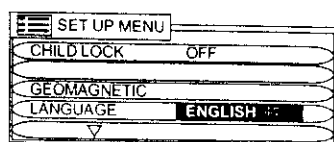

Aspect Controls



ASPECT

Press the ASPECT button  to select the different Aspect options. The options available are AUTO, 4:3, ZOOM, S-ZOOM, 16:9, 14:9 and JUST.

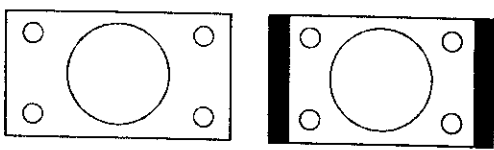
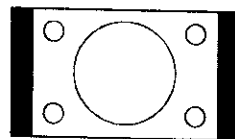
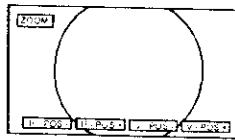
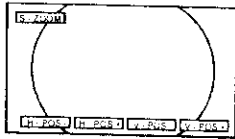
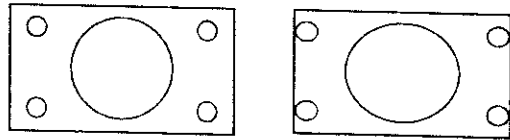
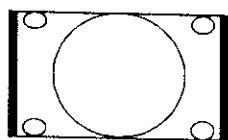
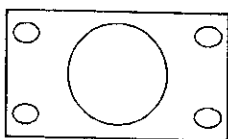
Mode	Picture	Description
AUTO	 <p>16:9 Signal 4:3 Signal</p>	The AUTO position can be set to 4:3 or to JUST. When a wide screen signal is detected at the Video terminal the TV will select the 16:9 aspect ratio.
4 : 3		This option will display a standard 4:3 picture without any stretching or compression. There will be vertical black lines down either side of the picture
ZOOM		This option allows you to magnify part of the picture. The coloured buttons let you change the position of the magnified area. Red H POS - Move picture Left Green H POS + Move picture Right Yellow V POS - Move picture Down Blue V POS + Move picture Up
S - ZOOM		S-ZOOM displays part of the picture at greater magnification than the ZOOM mode does. The coloured buttons let you change the position of the magnified area as shown for ZOOM..
16 : 9	 <p>16:9 Signal 4:3 Signal</p>	The 16:9 option will display the picture at its maximum size. Signals in the 4:3 format will be stretched to fit the picture.
14 : 9		The 14:9 option will display a 4:3 signal in simulated wide screen. The picture is slightly stretched. It is also slightly cropped top and bottom.
JUST		JUST gives you a "best fit" option when showing 4:3 on wide screen. The centre of the picture is not affected but there is some stretching at the edges.

TELETEXT Operation

Teletext is only available on certain broadcast channels. The time taken to display the pages and sub-pages is set by the teletext transmitter and not by the television.

Teletext is also used for Closed Captioning of television programmes for the hearing impaired. Closed captions can be found on Teletext Page 801.

TOP (Table Of Pages) MODE

In TOPTXT mode, the red button moves to the previous page number and the green button moves to the next page number. The yellow and blue buttons correspond to different subjects. These subjects can be accessed by Pushing the coloured button. This is the current preferred method of operation in Australia.

FASTEXT MODE

In FASTEXT mode, four differently coloured subjects are displayed at the bottom of the screen. To access more information about one of these subjects, push the corresponding colour coded button on the remote control. This is the current preferred method of operation in New Zealand.

LIST MODE

In LIST mode, four different coloured page numbers are shown at the bottom of the screen. Each of these numbers can be altered and stored in the TV's memory. These coloured page numbers correspond to the colour coded buttons on the remote control.

Please refer to page 20 for instructions on how to change modes between TOP/FASTEXT and LIST.

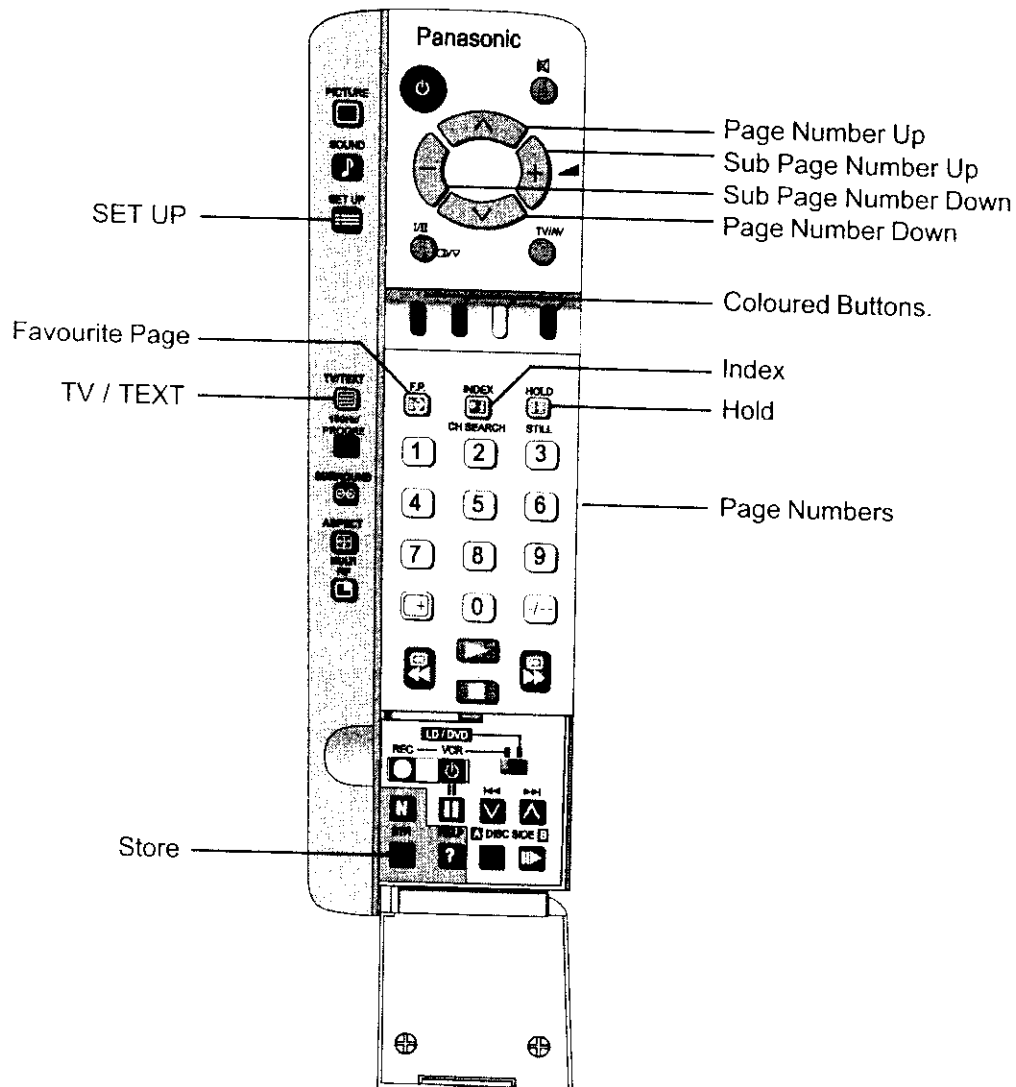

TELETEXT Operation

BUTTON WHAT IT DOES



F.P. (FAVOURITE PAGE)

This feature will store a favourite page in the TV memory.

1. The TV must be in the LIST mode, receiving a teletext broadcast and the programme number must be between 1 and 25.
 2. Push the Blue button.
 3. Select the page number.
 4. Push and hold the STR button.
 5. The page number is now stored.
- Push F.P. to recall this page.



SET UP

Used with the Coloured buttons to access the Reveal, Full / Top / Bottom, Display Cancel and Time Text functions.



Push the TV/TEXT Button  to return to normal television viewing.



TV / TEXT

Pressing this button switches the screen between:

- TELETEXT
- Television picture on the left of the screen and the TELETEXT on the right of the screen.
- Normal television viewing.

When TEXT is on, the sound from the broadcast channel is still audible. To adjust the volume press the Sound  button or the  button to display the volume indicator. The volume can then be adjusted normally.

STR



STR

This button is used to store page numbers into the coloured buttons or the Favourite Page button. The STR button is located behind the remote control door.



PAGE NUMBERS UP AND DOWN

These buttons are used to move to higher or lower page numbers.



SUB PAGE NUMBERS UP AND DOWN

These buttons are used to move to higher or lower sub page numbers.



COLOURED BUTTONS

These buttons refer to different page numbers in LIST mode and different subjects in TOP mode.



INDEX

Pressing this button returns you to the main index page.



HOLD

Some TELETEXT pages contain multi-page information. Use this button to stop the page changing. Push it again to release the hold.

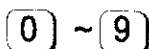



PAGE NUMBER BUTTONS

These buttons allow you to directly enter the page number that you want to view.



Please refer to drawing on Page 23 for location of Teletext Control Buttons.

TELETEXT Operation

REVEAL

Some Text pages contain concealed information, e.g. the solution to a puzzle. To reveal this information Push the Set Up  button followed by the Red  button. To hide the information, Push the Red button again.

F/T/B (FULL / TOP / BOTTOM)



This button is used when difficulty is experienced in reading text on the screen. To operate the F/T/B Push the Set Up  button followed by the Green  button.

Operating the F/T/B expands and displays the upper half of the screen. Operating the F/T/B Button again expands and displays the lower half of the screen. Operating the F/T/B Button a third time returns the display to normal condition.



DISPLAY CANCEL

If you wish to watch the television while you are waiting for a page to be transmitted you can use the DISPLAY CANCEL function.

This function is not available (or necessary) when the picture and the TELETEXT are both being displayed side by side.





Push the Set Up  button followed by the Yellow  button to view the TV picture while waiting for a teletext page to be transmitted. When found, the page number will be displayed at the top left of the screen.

News Flash or Other Updates



When a news flash page (or another page which provides regular updates) has been selected Push the Set Up  button followed by the Yellow  button to view the TV picture. When a news flash is received the page number will be displayed on the screen. Push the Yellow  button to display the news flash.

TIME TEXT *

When a Page has more than one screen (sub-page) of information, you may have to wait for some time before the sub-page you require becomes available. With this function it is possible to enter the number of the desired sub-page.

1. Select Text Mode and choose a page.
2. Push the Set Up  button followed by the Blue  button. T**** will be displayed at the top left of the screen.
3. Enter the sub page number before the T**** disappears. The sub-page number must be entered as a four digit number e.g. sub-page 3 would be entered as 0003. (If in LIST mode, a "T" will appear in the current box at the bottom).
4. Push the Yellow  button to view the TV picture while waiting for the subpage to be found. (This function is not necessary when the picture and the TELETEXT are both being displayed side by side).
5. When found, Push the Yellow  button

To clear the page perform one of the following:

- Push the Set Up  button.
- Select a new page number.
- Push the TV/TEXT Button  to return to normal television viewing.

* **Note:** TIME TEXT is not currently available in Australia.

Tuning Menu

FRONT PANEL CONTROLS

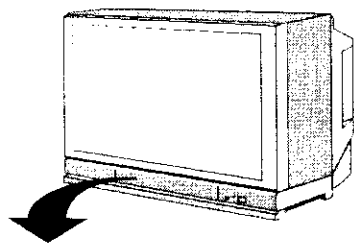

1. Push the **F** button repeatedly until the Tuning Menu is reached.
2. Push the **-/V** or **+/A** Button to select the Tuning Menu.
3. Push the **F** button to access the Tuning Menu.
4. Adjust the chosen option or menu using **-/V** or **+/A**.

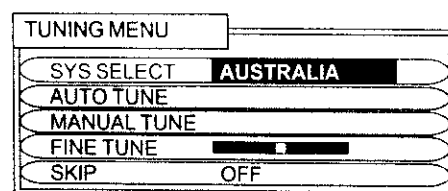

Pressing **STR** after making an adjustment will store the setting as the default (and will replace the factory setting).

Push the **F** button to return to the Tuning Menu.

Push **TV/AV** at any time to return to watching TV.

REMOTE CONTROL

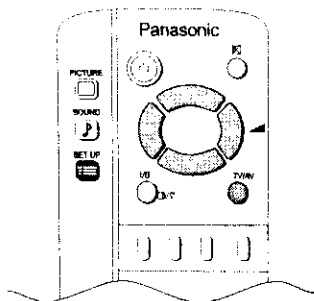

1. Push the SET UP button **SET UP**.
2. Select the Tuning Menu using **UP** or **DOWN**.
3. Access the Tuning Menu using **ENTER** or **EXIT**.
4. Move to the required option or menu using **UP** or **DOWN**.
5. Select, adjust or switch the chosen option using **ENTER** or **EXIT**.

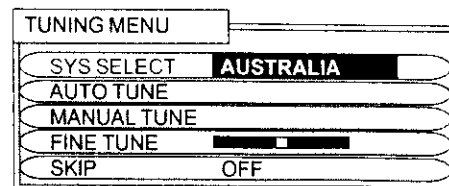

Pressing **STR** after making an adjustment will store the setting as the default (and will replace the factory setting).

Push the SET UP button **SET UP** to return to the Tuning Menu.

Push **TV/AV** at any time to return to watching TV.

Tuning Menu

Channel Allocation









The channel allocation is as follows:

SYS SELECT CH DISP	AUSTRALIA RECEIVED CHANNEL	NZ/INDONESIA RECEIVED CHANNEL
0	-	-
1	0	1
2	1	2
3	2	3
4	3	4
5	4	5
6	5	6
7	S2	7
...
11	S6	11
...
15	S10	-
16	6	-
...
19	9	-
20	9A	-
21	10	21
22	11	-
23	12	-
24	S11	-
...
28	-	-
57	S44	-
58	20	-
59	21	-
...
73	-	-
74	-	S'1
75	-	S'2
76	-	S'3
77	-	-
78	-	-
79	-	-
80	-	S1
81	-	S2
...
89	-	S10
...
118	80	-
...
120	-	S41
...
125	-	-











SYS Select

This option allows you to switch the television system between the Australian and the New Zealand / Indonesian system.

Using the Front Panel

1. Push the  button repeatedly until the Tuning Mode is reached. (See page 26).
2. Push the  or  Button to access the Tuning Menu.
3. Push the  button to select SYS SELECT.
4. Push the  or  Button to switch between AUSTRALIA and NZ/INDONES.
5. To return the television to normal operation push the  button on the remote control or repeatedly push the  button until the volume display appears.

Using the Remote Control

1. Push the Set Up () button.
2. Push the  or  button to access the Tuning Menu. (See page 26).
3. Push the  or  button to select the Tuning Menu.
4. Push the  or  button to select the SYS SELECT.
5. Push the  or  Button to switch between AUSTRALIA and NZ/INDONES.
6. Push the  button to return the television to normal operation.

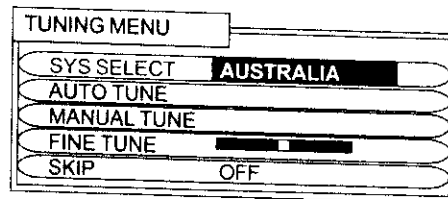

Tuning Menu





Auto Tune

This television has been factory tuned to all major city channels. Use the automatic tuning procedure only if you wish to reset ALL Programme Location Numbers. Refer to "Manual Tune" on page 30 if you only want to retune one or two Programme Location Numbers.



The television should be switched ON and the TV/AV Switch set to TV.

When you start the automatic search, the television will automatically search for television broadcasts through both VHF bands and the UHF band. During this process all of the available television broadcast channels will be automatically allocated to sequential Programme Number locations depending on the mode selected (See page 28).



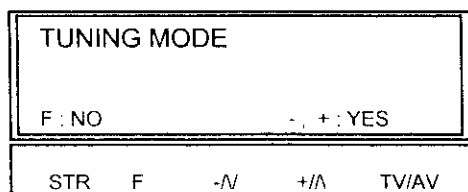





Using the Front Panel

1. Push the  button repeatedly until the Tuning Menu is reached. (See page 26).
2. Push the  or  Button to access the Tuning Menu.
3. Push the  button to access Auto Tune.





4. Push the  or  Button to start the search.

Using the Remote Control

1. Push the Set Up () button.
2. Push the  or  button to select the Tuning Menu. (See page 26).
3. Push the  or  button to access the Tuning Menu.
4. Push the  or  button to select the Auto Tune.
5. Push the  or  button to start the Auto Tune.

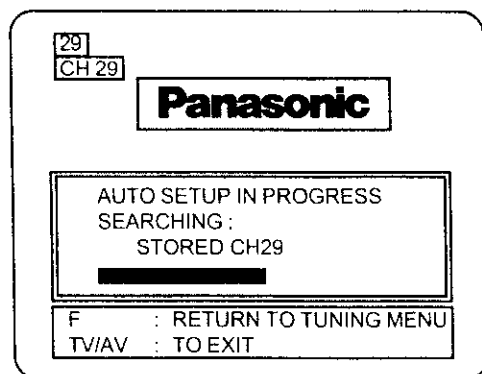
The television will automatically allocate each received broadcast signal to a Programme Number depending on the mode selected (See page 28). As each station is stored the Panasonic logo will appear momentarily. The operation will cease when all available channels have been tuned.



Push the  button to return the television to the Tuning Menu.

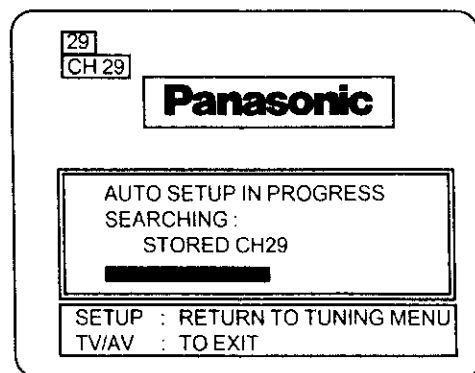

Push the Set Up () button to return the television to the Tuning menu.

Push the  button to return the television to normal operation.





Tuning Menu

Manual Tune









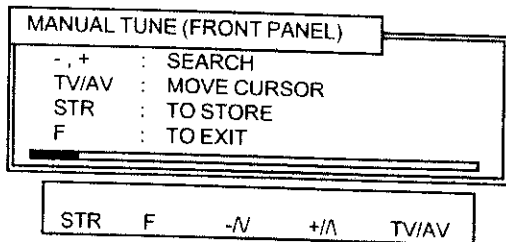

This Television has been factory tuned to all the major city channels. Use this tuning procedure only if you wish to reset individual Programme Numbers.

The television should be switched ON and the TV/AV Switch set to TV.







Using the Front Panel

1. Push the  button repeatedly until the Tuning Menu is reached.
2. Push the  or  Button to access the Tuning Menu. (See page 26).
4. Push the  or  button to access Manual Tune.









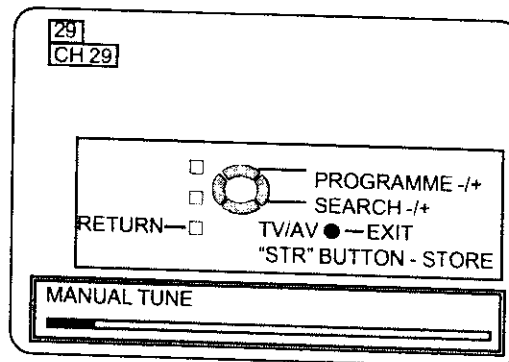

5. Push the  button to switch to "Change Programme".
6. Use the  or  buttons to select the programme location number to tune.
7. Push the  button to switch to "Search".
8. Push the  or  Button to start the search.
9. The television will automatically search for the next broadcast signal. As each station is found the search will stop. If you do not want this station restart the search.
10. Push the  to store the selected station.
11. Push the  button to return the television to the Tuning Menu.
12. To return the television to normal operation push the  button on the remote control or repeatedly push the  button until the volume display appears.

Using the Remote Control

1. Push the Set Up () button.
2. Push the  or  button to select the Tuning Menu. (See page 26).
3. Push the  or  button to access the Tuning Menu.
4. Push the  or  button to select the Manual Tune.



5. Push the  or  button to access the Manual Tune.
6. Push the  or  button to select the programme location number to tune.
7. Push the  or  button to start the search.
8. The television will automatically search for the next broadcast signal. As each station is found the search will stop. If you do not want this station restart the search.
9. Push the  to store the selected station.
10. Push the Set Up () button to return the television to the Tuning menu.
11. Push the  button to return the television to normal operation.

Tuning the Television to a VCR

1. Turn the VCR On and either start a known tape playing or set the VCR Test Signal, if fitted, to On (refer to the VCR operating instructions).
2. Repeat steps 2, 3 and 4 of the Manual Tuning procedure above. The television will treat the VCR as if it was a normal television broadcast station.

NOTES:











1. The antenna lead must be connected to the VCR and the VCR RF-Out must be connected to the TV RF-In. Please refer to page 36.
2. The picture and sound quality are usually much better if the VCR is connected using the AV Terminals. Please refer to page 37.

Tuning Menu













Fine Tune

In areas of poor reception or constant interference a slight adjustment to the tuning may improve the picture quality.

Using the Front Panel

1. Select the Programme location number you want to fine tune.
2. Push the  button repeatedly until the Tuning Mode is reached. (See page 26).
3. Push the  or  Button to access the Tuning Menu.
4. Push the  button to access Fine Tune.
5. Push the  or  Button to fine tune the station.
6. The television will fine tune in the direction chosen by you.
7. Push the  to store the selected station.
8. Push the  button to return the television to the Tuning Menu.
9. To return the television to normal operation push the  button on the remote control or repeatedly push the  button until the volume display appears.

Using the Remote Control

1. Select the Programme location number you want to fine tune.
2. Push the Set Up () button.
3. Push the  or  button to select the Tuning Menu. (See page 26).
4. Push the  or  button to access the Tuning Menu.
5. Push the  or  button to select the Fine Tune.
6. Push the  or  button to start the fine tune.
7. The television will fine tune in the direction chosen by you.
8. To store the selected station, push the .
9. Push the Set Up () button twice to return the television to the Set Up menu.
10. Push the  button to return the television to normal operation.









Canceling the Fine Tuning

To cancel the Fine Tuning follow the Manual Tune procedure on page 29.











Skip

This option allows you to "Skip" (bypass) the unused or undesired Programme Numbers. The Function is only applicable when the Programme Number Up or down buttons are Pushed. The use of the remote control Direct Programme Number Buttons overrides the Skip function.

Using the Front Panel

1. Select the Programme location number you want to "Skip"
2. Push the  button repeatedly until the Tuning Mode is reached. (See page 26).
3. Push the  or  Button to access the Tuning Menu.
4. Push the  button to select SKIP.
5. Push the  or  Button to turn the SKIP on or off.
6. To store the SKIP setting, push the .
7. To return the television to normal operation push the  button on the remote control or repeatedly push the  button until the volume display appears.

Using the Remote Control

1. Select the Programme location number you want to "Skip".
2. Push the Set Up () button.
3. Push the  or  button to access the Tuning Menu. (See page 26).
4. Push the  or  button to select the Tuning Menu.
5. Push the  or  button to select the SKIP.
6. Push the  or  button to turn SKIP on or off.
7. To store the SKIP setting, push the .
8. Push the  button to return the television to normal operation.

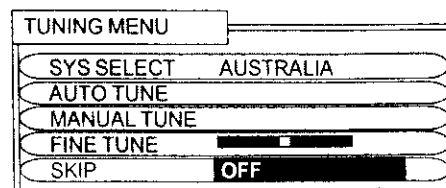

Geomagnetic Correction

Magnetic interference may come from such things as unshielded motors, moving the TV while it is switched ON, turning off a vacuum cleaner too close to the TV, lightning strikes nearby or many other things.

Slight tilting of the picture may be noticeable or coloured patches may sometimes appear at the corners of the screen (colour purity).

The Geomagnetic Correction feature can be used to eliminate some interference problems.

Quite often simply switching your Television OFF with the Power On/Off Switch (not with the remote control) for 30 minutes and then switching it back ON will cure the problem.

Geomagnetic corrections can be made from the remote control or from the TV set.

Using the Front Panel

1. Push the  button repeatedly to access the Geomagnetic Correction Menu.

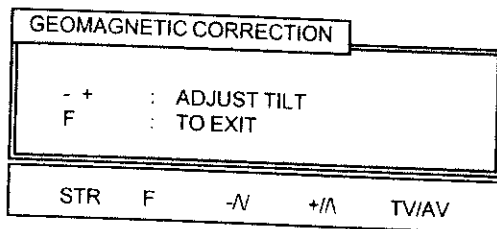





2. Push - / V or + / \ to adjust the picture tilt or coloured patches as necessary.





The adjustment range is from -8 to +8.

3. Push the F button to return to normal viewing.

Using the Remote Control

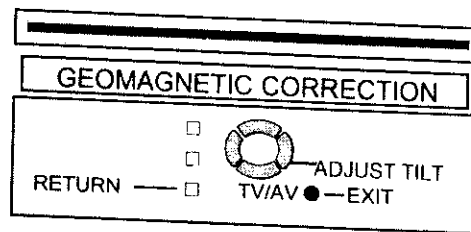
1. Push the SET UP button .
2. Select the Geomagnetic Correction Menu by Pushing  or .
3. Push  or  to access the Geomagnetic Correction.



4. Push  or  to adjust the picture tilt or coloured patches as necessary.

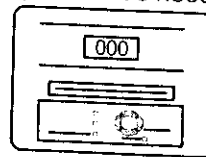

The adjustment range is from -8 to +8.

5. Push the SET UP button to return the TV to the Set Up Menu.

OR

6. Push the TV/AV button to return to normal viewing.



Helpful Hint

1. If geomagnetic changes cause colour patches on the screen switch your Television OFF with the Power On/Off Switch (not with the remote control) for 30 minutes and then switch it back ON.
2. Adjustment for geomagnetic should be performed every time the location of the TV is changed.
3. In some cases colour patches will not be completely eliminated even after adjustment, particularly in ferroconcrete buildings and other structures susceptible to geomagnetic effects. In these cases the TV location will have to be changed.

Remote Control VCR/LD/DVD Operation

This remote control has been designed to work with a variety of VCRs, Laser Disc players and DVD players.

Please refer to page 36 for details of manufacturers' codes.

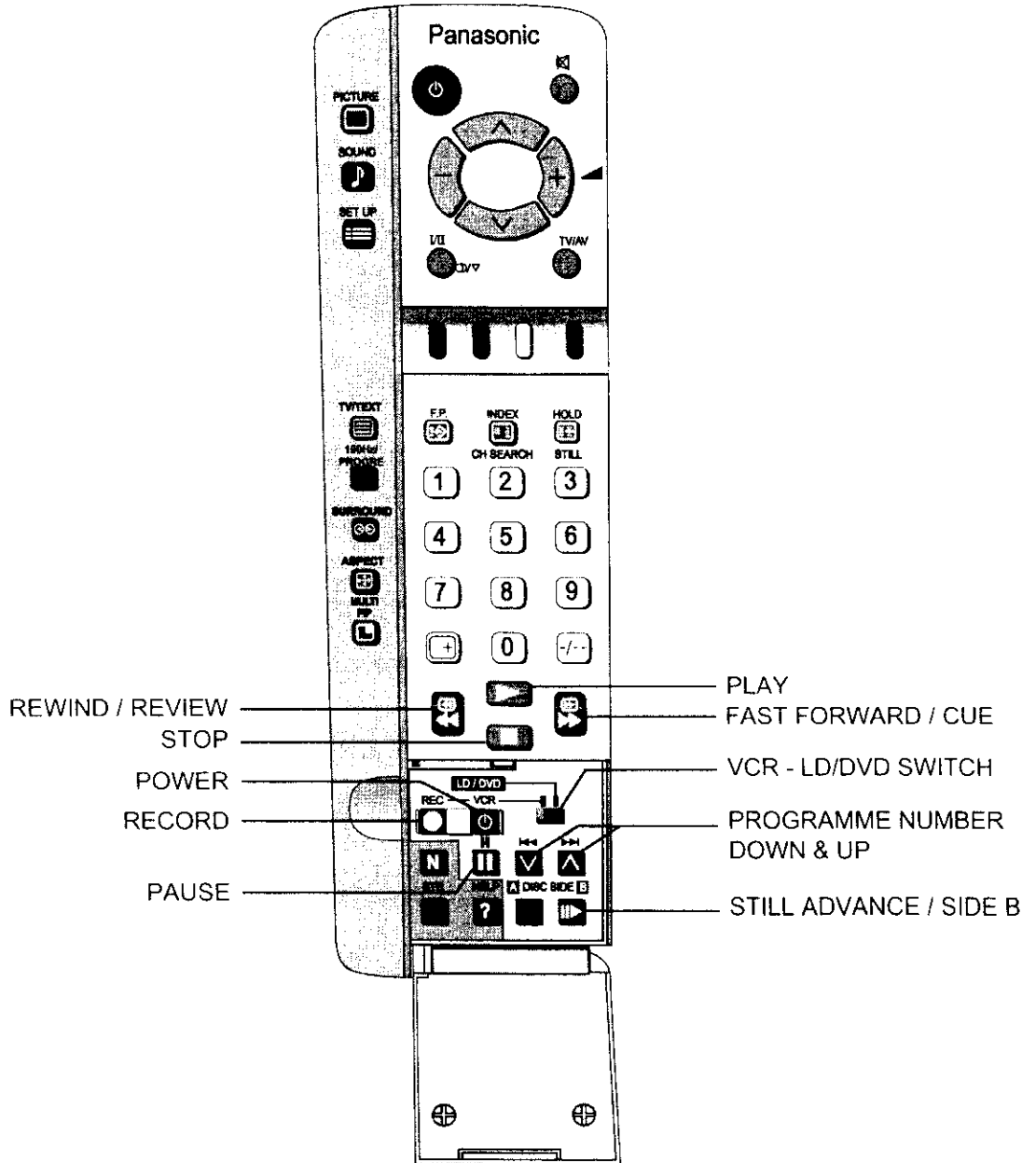











* WARNING:

Unauthorised recording of material from Television Broadcasts or from other video and/or audio sources may contravene copyright laws.

Remote Control VCR/LD/DVD Operation

Remote Control VCR/LD/DVD Buttons

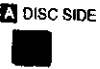



Button / Switch	Function	
	VCR	LD/DVD
	REWIND / REVIEW Used to rewind the tape quickly or watch the tape in reverse.	REWIND / REVIEW Used to play the disc in reverse while watching the picture.
	STOP Used to stop the VCR.	STOP Used to stop the LD/DVD.
	POWER BUTTON Used to switch the VCR ON or OFF (Standby).	POWER BUTTON Used to switch the LD/DVD ON or OFF (Standby).
	RECORD Push both buttons to Start recording.	
	PAUSE Pauses the tape during play.	PAUSE Pauses the disc during play.
	PLAY Used to start the VCR playing.	PLAY Used to start the LD/DVD playing.
	FAST FORWARD / CUE Used to wind the tape forward quickly or to watch the tape at fast speed	FAST FORWARD / CUE Used to watch the disc at fast speed.
	VCR Switch Setting Selects VCR	LD/DVD Switch Setting Selects LD/DVD.
	PROGRAMME NUMBER DOWN AND UP Used to select the next Higher or lower programme. Number.	PROGRAMME SKIP Used to skip tracks on the disc.
		DISC SIDE B SELECTION Used to select the B side of the disc.
		DISC SIDE A SELECTION Used to select the A side of the disc.

Please refer to drawing on Page 32 for location of VCR/LD/DVD Control Buttons.

Remote Control VCR/LD/DVD Operation

Manufacturers' Code Settings

This remote control has been designed to work with a variety of VCRs, Laser Disc players and DVD players. In order for this to occur, the setting for the VCR, LD or DVD must be programmed into the Remote Control.

- To set a VCR, slide the remote control VCR-LD/DVD switch  to VCR.
To set a LD or DVD, slide the remote control VCR-LD/DVD switch  to LD/DVD.
- Push the remote control VCR - LD/DVD Power Button  and keep it Pushed.
- Enter the Manufacturer's two-digit code number using the remote control Number Buttons **0** ~ **9** (The codes are shown below).
- Push the STOP button .
- Release the remote control VCR or LD/DVD Power Button .
- Check the operation of the VCR, LD or DVD. If it does not operate correctly, repeat steps 1 to 5 and use an alternate code (if there is one).

VCR CODES

Manufacturer	Code	Manufacturer	Code
Panasonic / National	10, 11, 12, 13	NEC	40, 41, 42, 43
AIWA	15, 16	ORION	45, 46
FUJITSU	20	Philips	50
HITACHI	25, 26, 27	SANYO	55, 56, 57, 58
JVC	30, 31, 32	SHARP	60, 61
MITSUBISHI	35, 36	SONY	65, 66, 67
		TOSHIBA	70, 71

LD CODES

Manufacturer	Code	Manufacturer	Code
Panasonic	10, 11, 12, 13	SAMSUNG	30
KENWOOD	15, 16	SHARP	35
PHILIPS	20	SONY	40, 41, 42, 43
PIONEER	25		

DVD CODES

Manufacturer	Code	
Panasonic	70	

NOTES:

- If the batteries are removed from the remote control the Manufacturer's codes are lost and must be reprogrammed.
- The list of manufacturer's codes is given as a guideline only. Panasonic cannot guarantee that any other manufacturer's product will work with this remote control.

Connecting Equipment to the TV

***** NOTE *****

Headphones and connecting cables for Antennas, VCRs, LDs DVDs, Amplifiers and Speakers etc. are not supplied with this television.

Front Panel Connections

The front input terminals allow quick and easy access for computer games, video cameras and other equipment which is not usually permanently connected.

AV Equipment

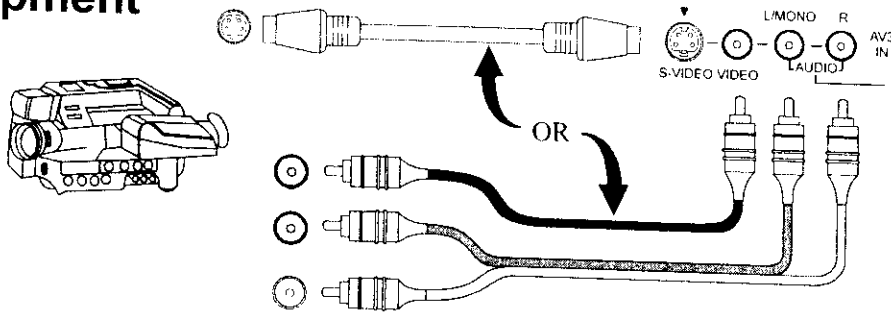

Headphones

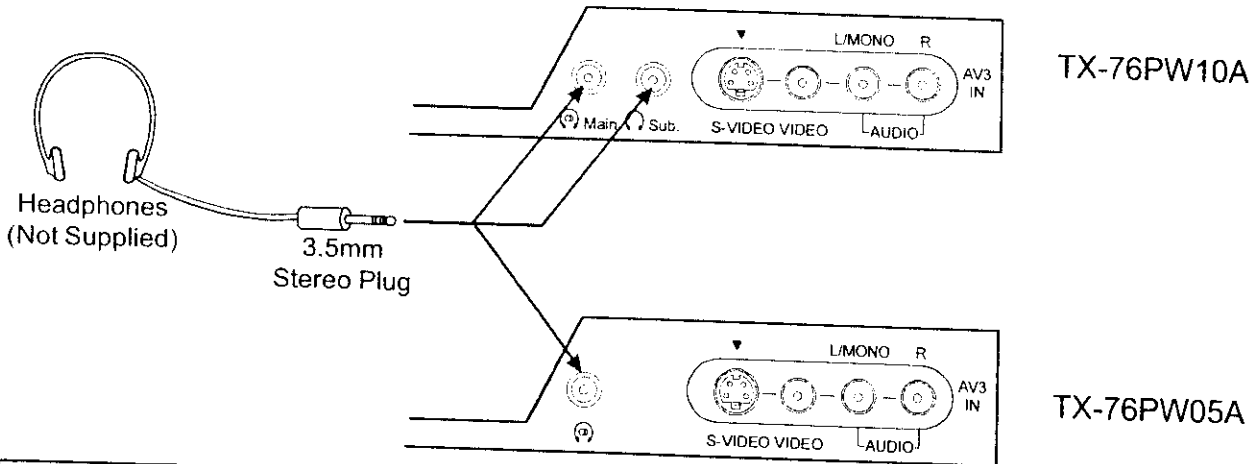

Screen Condition		Speaker Sound	Main Headphones	Sub Headphones	Monitor Output
Single picture/ Teletext	A	A (Stereo)	A (Stereo)	A (Stereo)	A (Stereo)
Picture in Picture	A B	A (Stereo)	A (Stereo)	B (Mono)	A (Stereo)
Picture in Picture CHANGE	B A	B (Stereo)	B (Stereo)	A (Mono)	B (Stereo)

Connecting Equipment to the TV

Rear Panel Connections

When using a VCR with the television *always* connect the Aerial to the VCR and connect an RF Cable (not supplied) between the VCR RF-Out and the television RF-In.

You can watch videos by either tuning the television to the VCR (see page 30) or by connecting the VCR to the rear AV terminals.

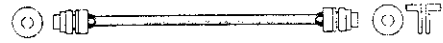

RF Cable

Note: When connecting a mono VCR through the RF-In, please switch the TV to mono.

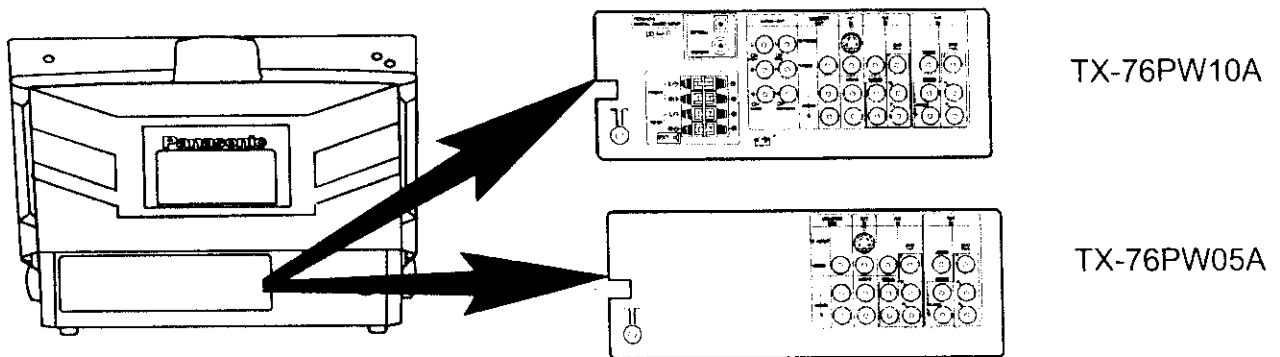

Monitor Out

The Monitor Out terminals reproduce the signals currently on the television screen. The on-screen signals could be a television programme or signals connected to one of the AV inputs.

The Monitor Out facility can be used to allow one video source (videotape, video disc etc.) to be connected to more than one television. Connect the Monitor out from this television to the AV Input of the second television.

If a video recorder is connected to the Monitor Out and video sources (VCR, video disc, camera etc.) are connected to one or more of the AV inputs, the television becomes a visual display for tape editing or copying. Unauthorised recording of material from Television Broadcasts or from other video and/or audio sources may contravene copyright laws.

The Monitor Out Audio can also be connected to a stereo amplifier or other hi-fi equipment.

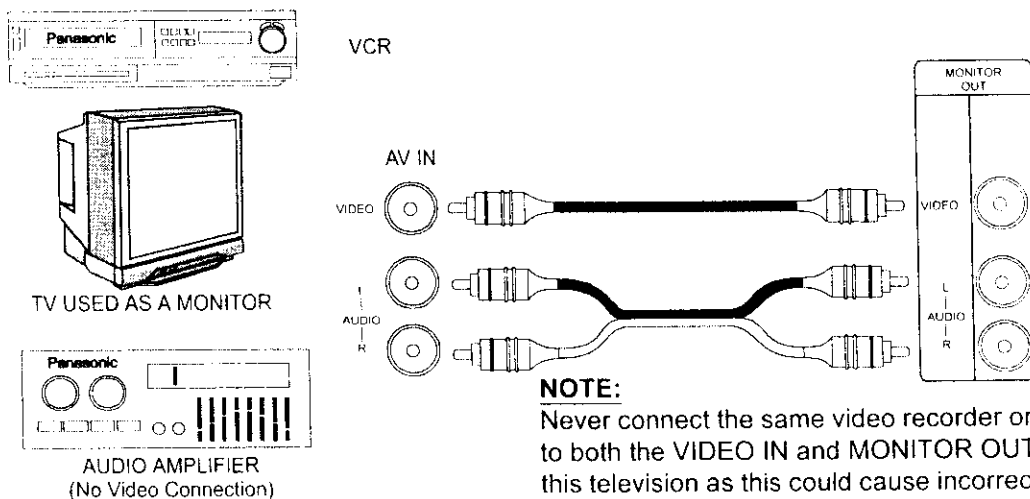

Connecting Equipment to the TV

Connecting a Standard VCR to the AV Input

Most standard Video Cassette Recorders use RCA type video and audio connectors. If your VCR has different type connectors please refer to the VCR instruction book for details.

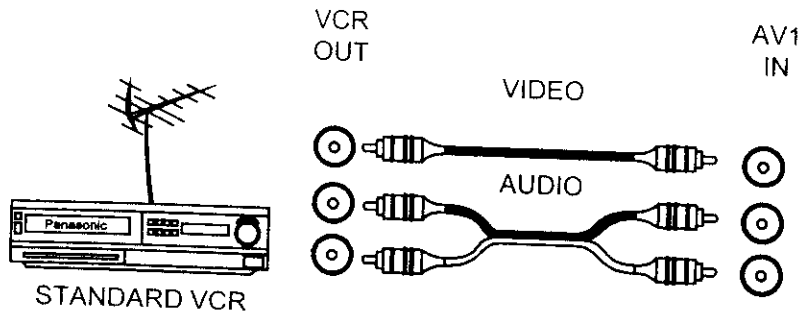

NOTE: A mono VCR can be connected to this television. Connect the VCR Audio out to the Left Audio input on the television. The sound will automatically be directed to both speakers.

Connecting S-Video Equipment to the AV Input

S-Video equipment uses a 4Pin Mini Din (Male) plug for the video and RCA plugs for the audio. When an S-Video cable is connected to an S-Video input terminal, the RCA video terminal for that AV position will be disconnected.

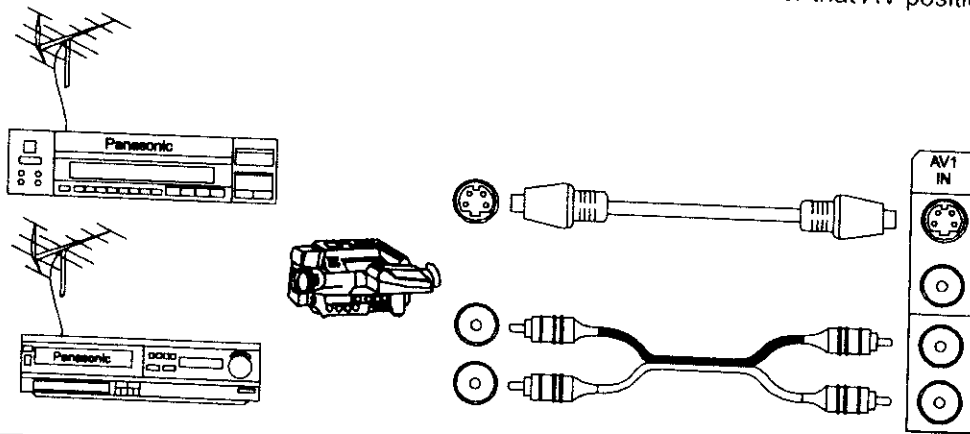

Connecting DVD Equipment to the AV Input

The audio and video inputs on the television are RCA type connectors. Connect the Y, PB and PR outputs from the DVD to the AV4 IN DVD Inputs on the television, as shown below. Connect the "AUDIO OUT" to the AV4 IN AUDIO terminals on the television.

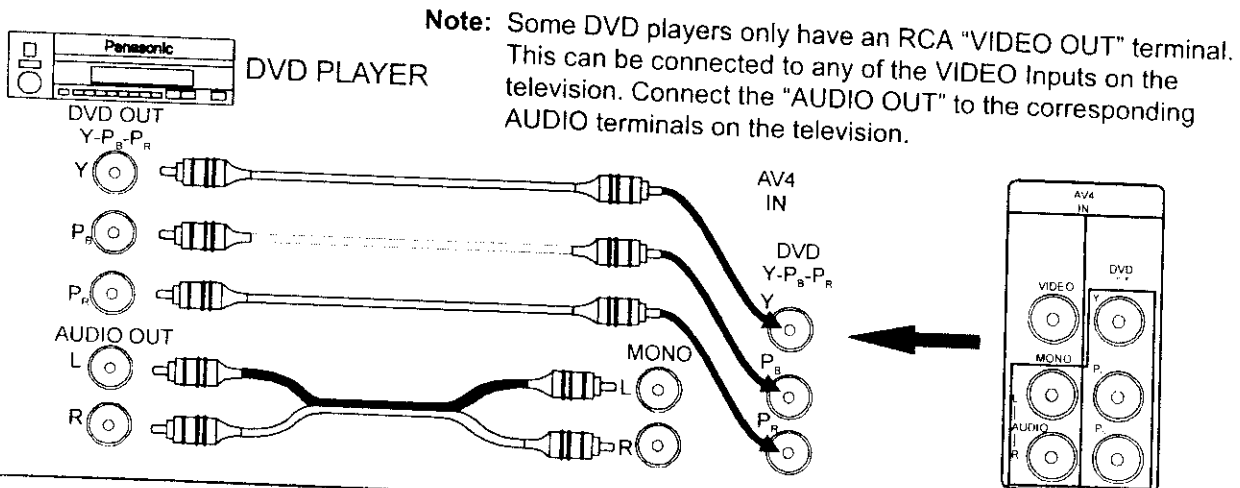

Note: Some DVD players only have an RCA "VIDEO OUT" terminal. This can be connected to any of the VIDEO Inputs on the television. Connect the "AUDIO OUT" to the corresponding AUDIO terminals on the television.

Connecting Equipment to the TV

Connecting the Audio Out Terminals (TX-76PW10A only)

The Audio Out sockets on the rear of the TV allow you to create a custom sound system using an external amplifier and external speakers.

You may decide, for example to use an external DTS/Dolby Digital amplifier to connect external left and right front speakers, left and right rear surround speakers and a subwoofer (LFE speaker) as shown below.

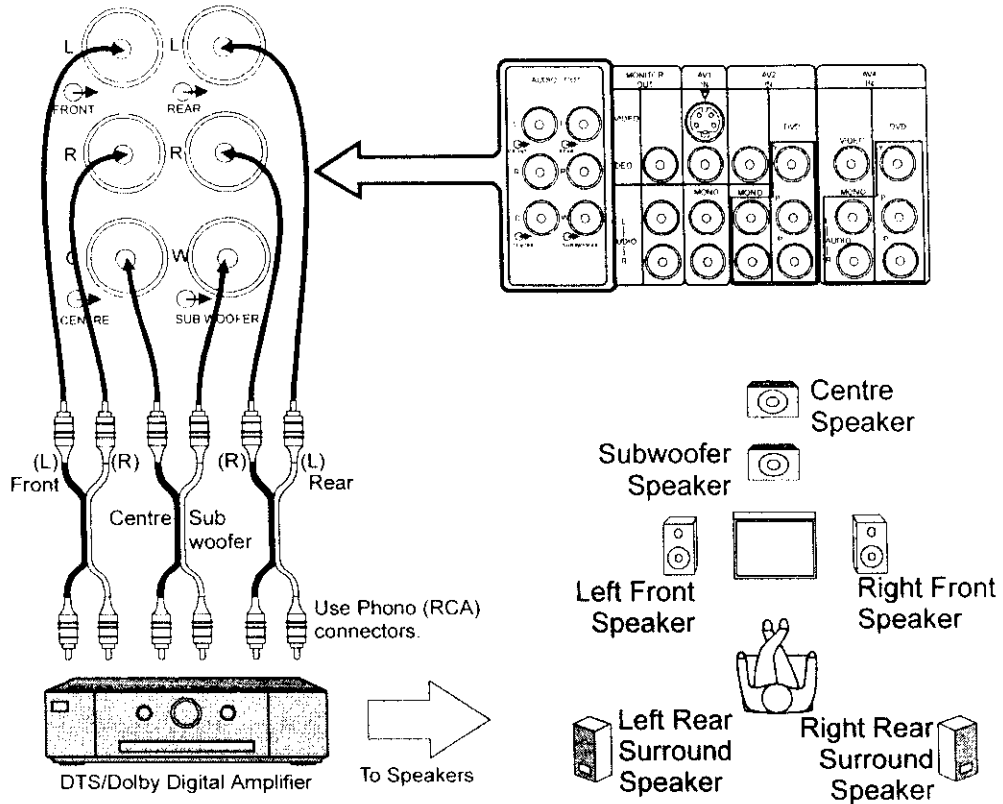

Connecting the Digital Audio Input (TX-76PW10A only)

Additional equipment can be connected to the rear of the AV1/AV2/AV3/AV4 and via the two digital audio input sockets (coaxial or optical)

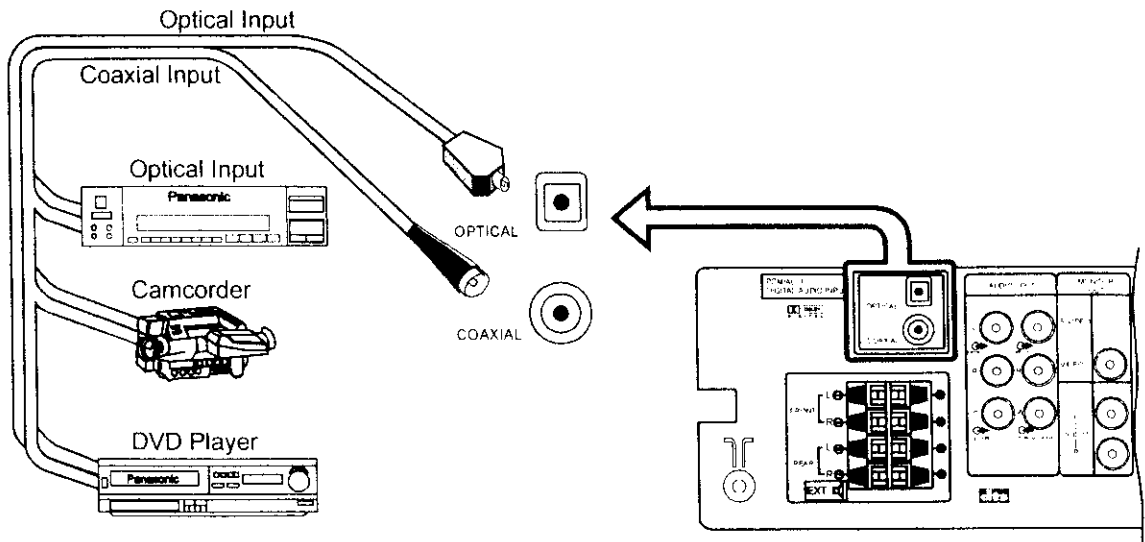

Connecting Equipment to the TV

Connecting the External Speakers (TX-76PW10A only)

The external speaker connections (EXT) on the rear of the TV allow you to create your own system using external speakers.

You may decide, for example, to connect external left and right front speakers and left and right rear surround speakers as shown here.

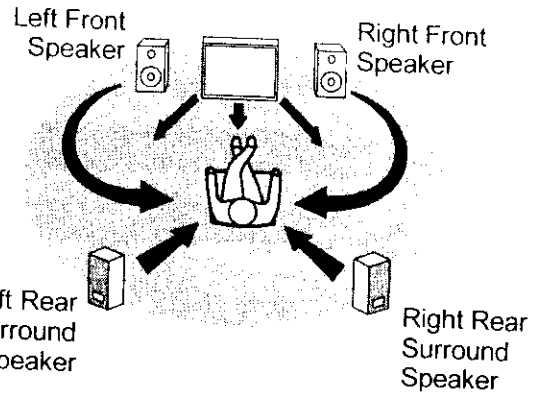

The TV must be turned OFF before connecting external equipment.

1. Twist the bare wire ends of the speaker wires before inserting into the speaker terminals.

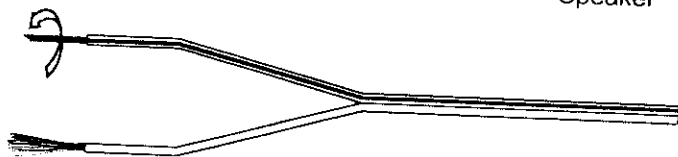

2. Insert into terminals. Ensure that bare speaker wires are not touching and are fully inserted into the terminals.

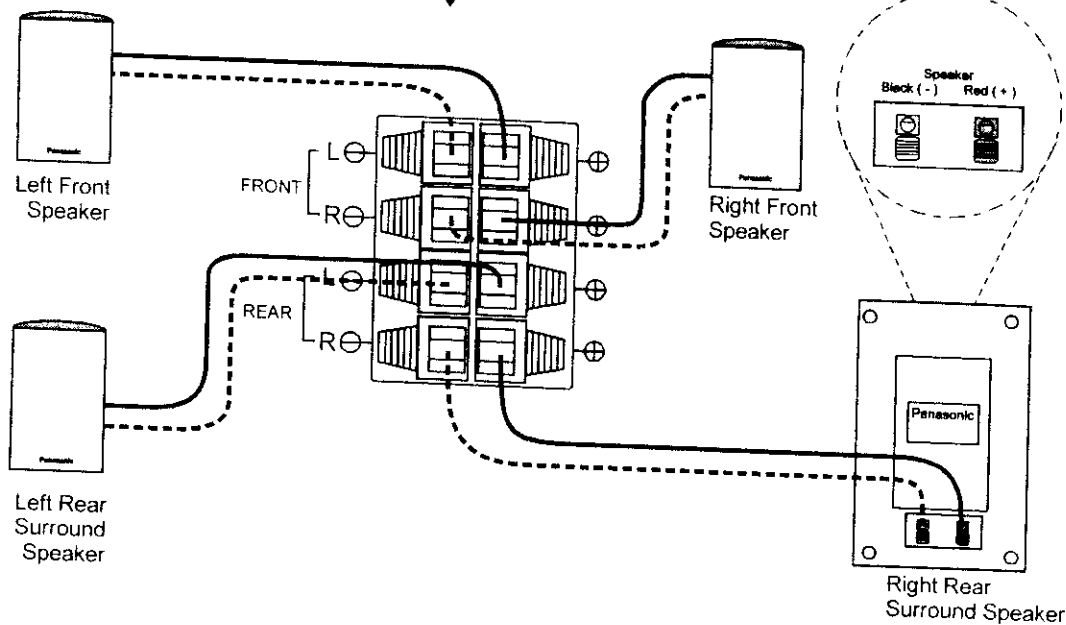
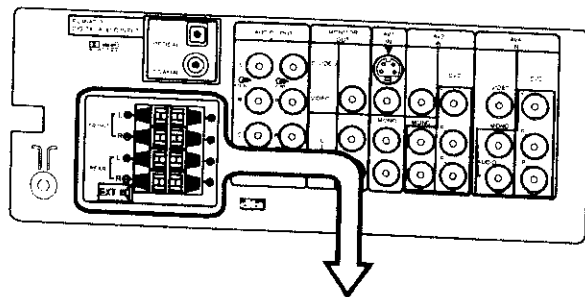
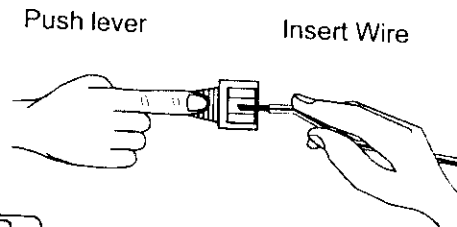

Customer Information

To keep your Panasonic Television in good working order please observe the following warnings and cautions. Please be careful with this television. Like all electrical equipment it can cause serious injury or damage if it is mistreated.

Warnings

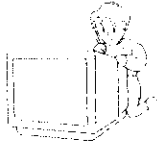

Danger
Do not insert foreign objects. (Keep metal or easily inflammable objects out of this television).

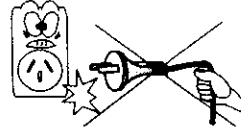

Danger
Always pull the plug out of the wall outlet by holding the plug itself.
Do not pull the plug by the power cord.

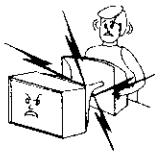

Danger: High Voltage
Do not remove the rear cover, as High Voltage components will be exposed.



Danger
Do not alter the power cord.
Do not use if the power cord or plug is damaged or if the plug does not fit tightly into the socket.

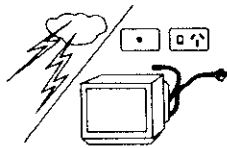

DO NOT touch the aerial cable and metal parts of the television when there is lightning around. During storms switch the television off. **DO NOT** leave in standby. Remove the plug from the wall socket.



Do not allow the power cord to come into contact with flame or hot surfaces.

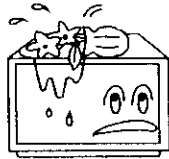

Do not place any containers of water or other liquids on or near this television.

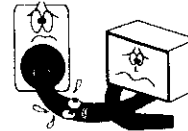

Do not place heavy objects on the power cord.

Cautions

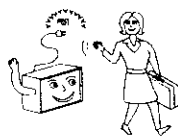

Remove the Power Plug from the wall socket when the Television is not going to be used for an extended period of time.

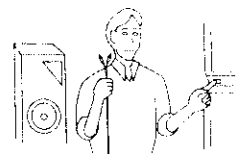

Turn the power OFF before connecting other electrical equipment.

Safety First

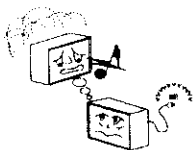

In the advent of unusual operation (e.g. odd sounds, smoke or aromas), turn the television Off and remove the power cord from the wall socket. Then call the Television Service Centre: this may reduce the possibility of expensive repair costs.

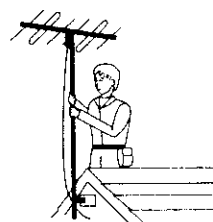

Any external aerial should be installed by a reputable qualified installer and should comply with Australian Standard AS1417.1.

Customer Information

Cleaning the Television

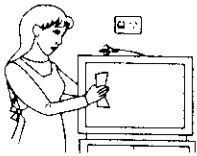

Cabinet and Picture Tube Care

The cabinet and picture tube can be kept in good condition by wiping with a clean, lint free cloth moistened with mild detergent and water. For safety, remove the plug from the power outlet when cleaning.

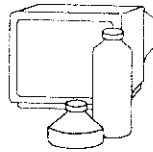

This television contains many plastic parts. For this reason **Do Not** use benzene, thinners or any solutions containing petroleum or other chemicals.

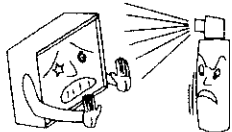

Do not spray insecticide or volatile solvent on the TV. **Do not** allow rubber and vinyl products to stay in contact with the TV for long periods of time. They may cause changes in paint quality.



Remove dirt and soiling by wiping with a soft cloth. Even if the television is heavily soiled do not apply cleaner directly to the unit. Soak a cloth in a solution of neutral cleanser thinned with water. Wring out the cloth, wipe the television clean and finish by wiping with a dry cloth.

Locating the Television



Do not place the TV in humid or dusty locations, or areas exposed to smoke or steam. Avoid exposing the television to direct sunlight or any other sources of direct heat.

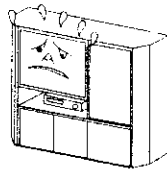

Adequate ventilation is essential. Allow a gap of at least 10cm around the TV, even in a cabinet or between shelves.

Caring for the Television

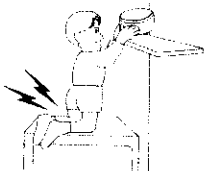

Do not stand or place heavy objects on top of the television.

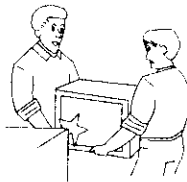

Do not subject the TV to any physical shocks. Always remove any connector cables when moving the TV. When moving the TV from one place to another wrap it in something protective.











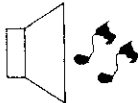

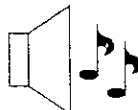

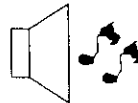

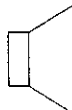
Caring for the Remote Control

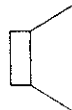
The lens of the Remote Control should be kept clean and free of dirt and grease. Use a soft cloth moistened with water and a mild detergent to keep the lens clean.

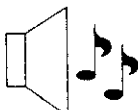

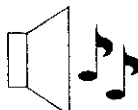
Troubleshooting

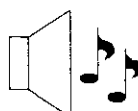
Before calling for service, determine the symptoms and make a few simple checks as shown below.

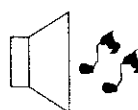
Picture	Sound	Check
 Snowy Picture	 Noisy Sound	Aerial Location, Direction or Connections. If you are watching a tape playback check the state of the Video heads – they may need to be cleaned or replaced. The tape may be old. Check the tracking.
 Multiple Image	 Normal Sound	Aerial Location, Direction or Connections.
 Interference	 Noisy Sound	Electrical Appliances, Motorcycles, Cars or Fluorescent Lamps.
 Normal Picture	 No Sound	Volume (Check the Mute function)
 No Picture	 No Sound	Not plugged in, switched OFF or Set to Stand By. Check volume, brightness, and contrast levels. Various internal safety devices may have been triggered. Switch the TV off for a few minutes and try again.
 No Colour	 Normal Sound	Colour Control. If the picture is from a tape playback, try adjusting the tracking.
 Scrambled	 Normal or Weak Sound	Retune the Television. Refer to page 29.
 Colour Patches	 Normal Sound	Magnetic Interference from unshielded equipment or the television may have been moved while it was switched ON. (Switch the television OFF with the main power switch and leave it OFF for about 30 minutes. Refer to page 31.
 Rolling Picture	 Noisy Sound	Picture Menu (Refer to page 13). Sound Menu (Refer to page 15).

Specifications

Tuning System	Frequency synthesized 100 Position (0 to 99).	
RF Channels	VHF 0 to 12 UHF 21 to 69 S'1 to S'3 S1 to S41	PAL B PAL G HYPER TUNER
Receiving Systems	1. PAL B/G	Reception of Off air broadcasts Playback from Video Tape Recorders
	2. NTSC 4.43 3. NTSC 3.58 4. PAL 60Hz	Playback from Special Video Tape Recorders and Special Video Disc Players (Via the AV Sockets) only.
Power Requirements	220 ~ 240Volts \pm 10% 50Hz	
Power Consumption	211W Max	3W Stand-By
Chassis	EURO7	
Picture Tube	76cm Viewable (Measured diagonally)	
Audio Output	Two Way Four Speakers Plus AFB Woofer (10W + 10W + 12W)	
External Speaker Connections	10W x 4Speakers (Not supplied) TX-76PW10A	
Headphone Socket	3.5mm Stereo (Main and Sub)	TX-76PW10A
	3.5mm Stereo (Main)	TX-76PW05Z
Aerial Impedance	75 Ω Unbalanced coaxial	
Component Video	1080i and 576P 576P	TX-76PW10A TX-76PW05A
Video / Audio Terminals	AV1 IN (Rear)	: S-Video, Video, Audio L/R Terminals
	AV2 IN (Rear)	: Video or Y/P _B /P _R , Audio L/R Terminals
	AV3 IN (Front)	: S-Video, Video, Audio L/R Terminals
	AV4 IN (Rear)	: Video or Y/P _B /P _R , Audio L/R Terminals
Digital Audio input	coaxial, optical TX-76PW10A	
Video / Audio Input	S-Video	Y : 1.0Vp-p 75 Ω C: 0.3Vp-p 75 Ω
	Video in	1.0Vp-p, 75 Ω
	Audio in	Approx. 400mV 1k Ω
Monitor Out	Video Out	1.0Vp-p, 75 Ω Audio Out Approx. 400mV 1k Ω
Accessories Supplied	Remote Control EUR511226 TX-76PW10A EUR511216 TX-76PW05A 2 Type 'AA' Batteries Instruction Manual TQB4A0145	
Dimensions	W = 77.7cm	D = 53.53cm H = 61.13cm
Weight	60kg (Net)	
Note: Design and Specifications are subject to change without notice. Weight and Dimensions shown are approximate.		

Customer's Record

The serial number of this product can be found on its rear cover and on the carton. It is recommended that you note the serial number and other details in the space provided and retain this booklet in a safe place as a permanent record of your purchase to aid in identification in the event of theft or loss.

Model No. _____

Serial No. PA - _____

Purchase Date _____

Purchased From _____

AUSTRALIA



www.panasonic.com.au

NEW ZEALAND

**Distributed in New Zealand by
Panasonic New Zealand Limited**

350 Te Irirangi Drive
East Tamaki, Auckland

Customer Care Center

Ph: 0800 726 276

Email: Customerservice@panasonicnz.co.nz

www.panasonic.co.nz

Matsushita Electric Co. (Aust) Pty Ltd

P.O. Box 326 Penrith NSW 2751

ACN: 000 611 389

Certified to International Environmental Standard ISO14001

Certified to International Quality Standard AS/NZS ISO9001



Printed in Australia



TQB4A0145