

# **Panasonic**

Colour Television  
**TC-29V50R**

## **Operating Instructions**

Please read these instructions completely before operating this set

TQB620981

# Contents

<b>Warnings and Cautions</b> .....	<b>4</b>
<b>Battery Installation and Replacement</b> .....	<b>5</b>
<b>Locations of Control ( Front View )</b> .....	<b>6</b>
<b>Locations of Control ( Rear View )</b> .....	<b>7</b>
<b>Remote Control ( TV Operation )</b> .....	<b>8</b>
<b>Remote Control ( VCR Operation )</b> .....	<b>9</b>
<b>How to Connect an External Antenna</b> .....	<b>10</b>
<b>How to Connect the Audio and Video Terminals</b> .....	<b>11</b>
<b>How to Connect the Audio and S-Video Terminals</b> .....	<b>12</b>
<b>How to Connect the Audio, Video and S-Video Terminals</b> .....	<b>13</b>
<b>How to Tune in Your TV Set ( Automatic and Manual Search )</b> .....	<b>14</b>
<b>Fine Tuning Operation</b> .....	<b>15</b>

# Contents

<b>General Operation on the TV Set</b> .....	<b>16~17</b>
<b>Remote Control Operation</b> .....	<b>18~22</b>
<b>VCR Operation</b> .....	<b>24</b>
<b>Troubleshooting</b> .....	<b>25</b>
<b>Specifications</b> .....	<b>26~27</b>
<b>General Information</b> .....	<b>27</b>

# Dear Panasonic Customer

Welcome to the Panasonic family of customers. We hope that you will have many years of enjoyment from your new colour television.

## Warnings and Cautions

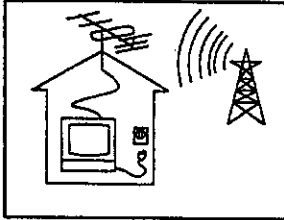

The TV set can be operated on  
AC Auto 110 ~ 240 V, 50/60 Hz.  
AC 230 V, 50 Hz (Only for  
New Zealand)

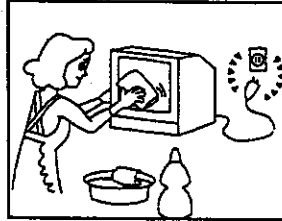

The cabinet and picture tube can be kept in good condition by simply wiping with a clean, soft cloth moistened with mild detergent and water. Do not use solutions containing benzol, petroleum or a chemical cloth. For safety, remove the plug from the wall outlet.

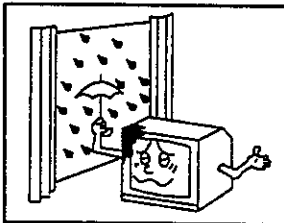

To prevent damage which may result in fire or electrical shock, do not expose the TV set to rain or excessive moisture.

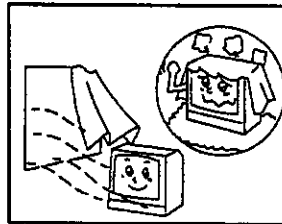

Adequate ventilation is essential to prevent failure of electrical components.

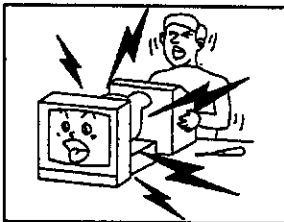

### High Voltage :

Do not remove the rear cover, as live parts are accessible when it is removed.

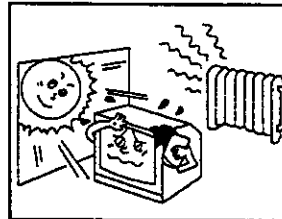

Avoid exposing the TV set to direct sunlight and other source of heat.

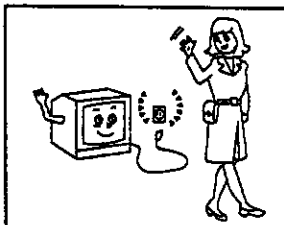

Remove the plug from the wall outlet ( Power point ) when the TV set is not used for a prolonged period of time.

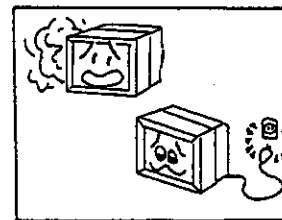

Do not used this set if abnormal operation occurs.  
EX: smoke, odd sounds or smells, turn the power switch off and disconnect the AC power if you notice any unusual operation.

# Battery Installation and Replacement

## Battery Installation

Batteries : Use two " R6 " size dry cells.

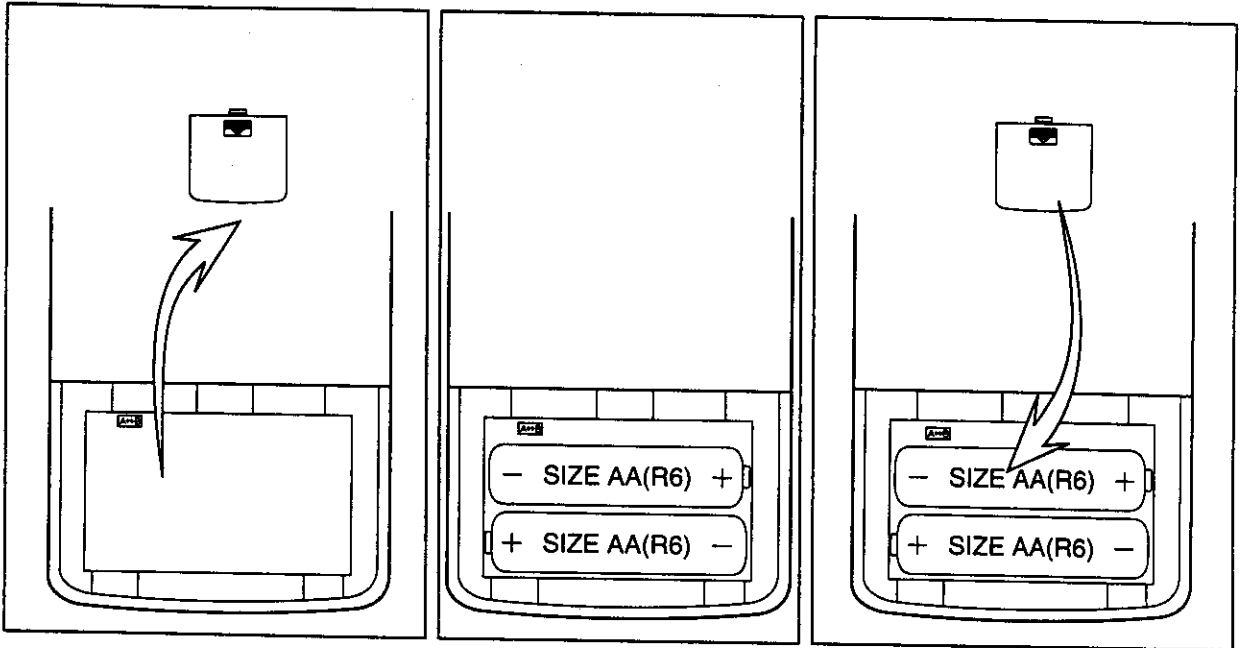

1. Remove the remote control battery compartment lid by pressing it to the bottom side.

2. Insert the batteries correctly by observing the polarities (+) and (-).

3. Replace the cover.

## Battery Precautions

Incorrect use of batteries can cause electrolyte leakage which will corrode the remote control transmitter or cause the batteries to burst.

The following precautions must be carefully observed.

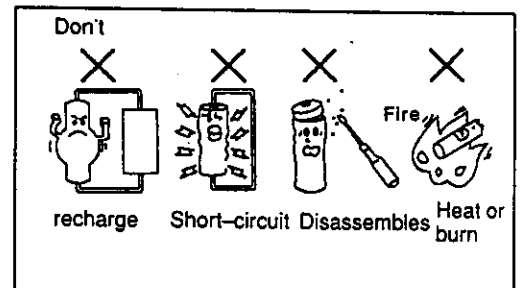
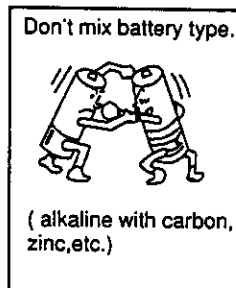
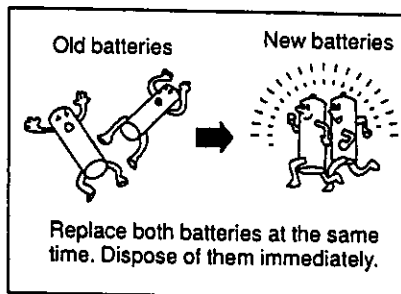

# Locations of Control ( Front View )

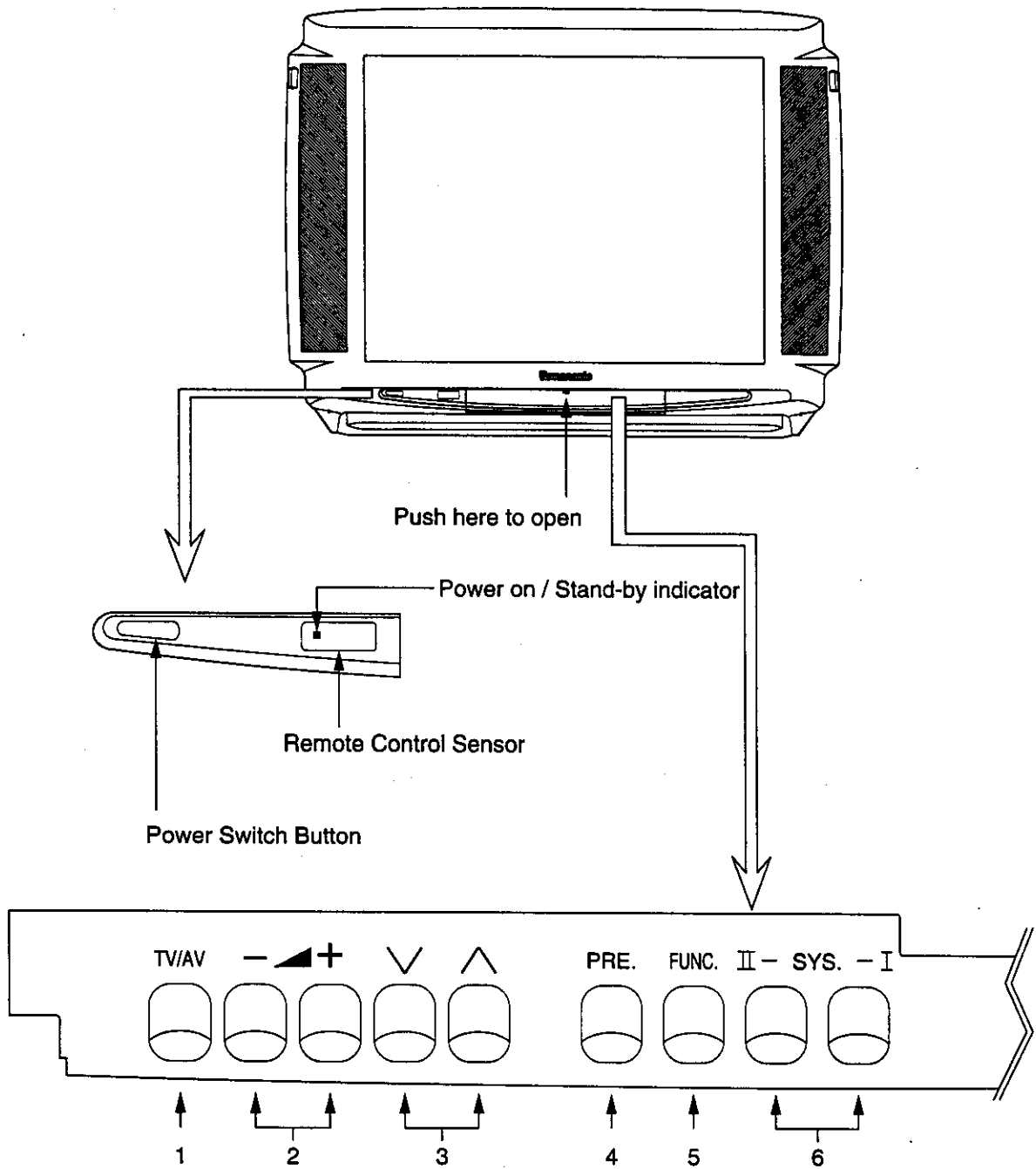

Note: Operating instructions for numbers 1~6 are explained on page 16~17.

# Locations of Control ( Rear View )

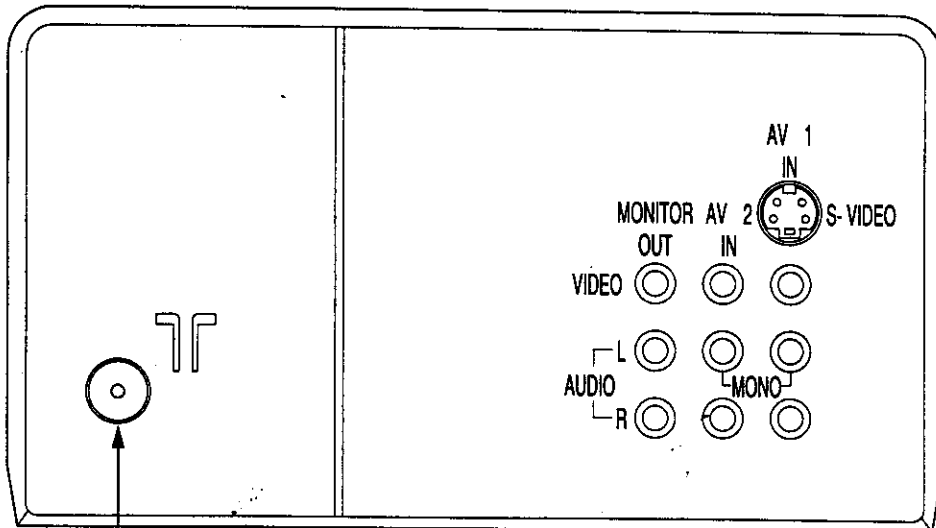
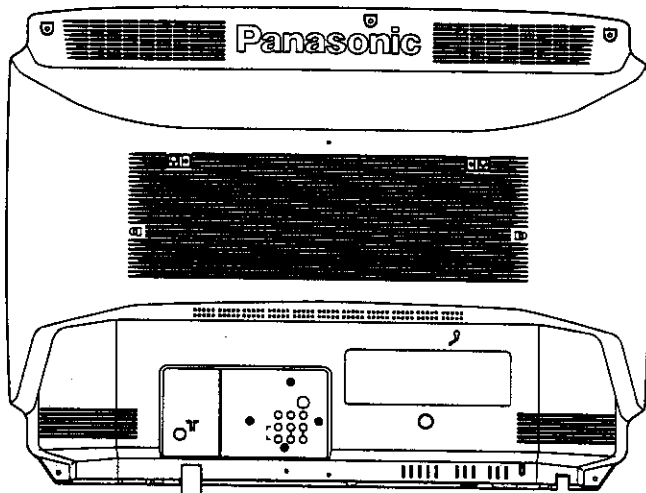

Aerial Terminal

# Remote Control

Refer to the pages indicated in ● for details.

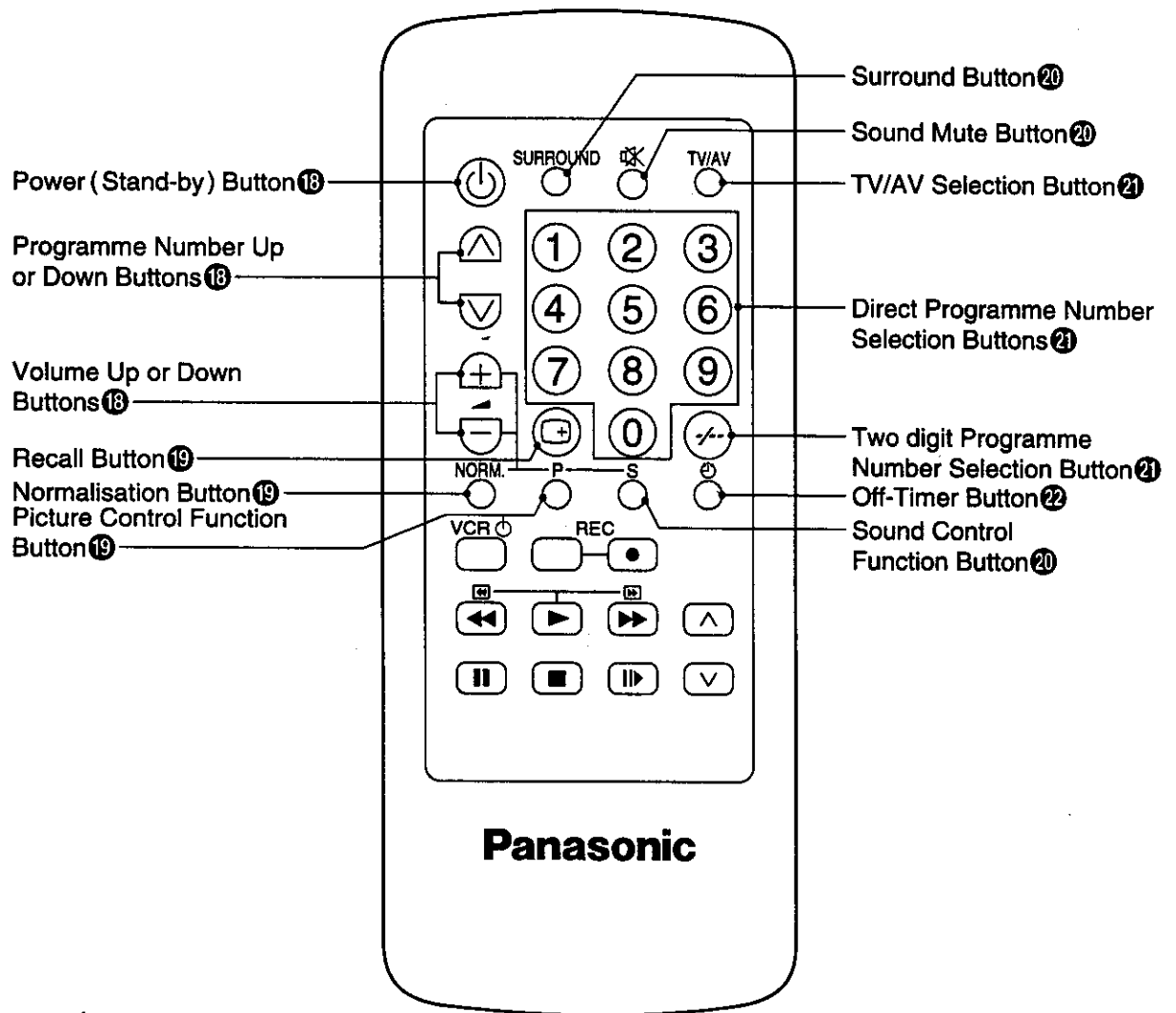



# Remote Control

Refer to the pages indicated in ● for details.

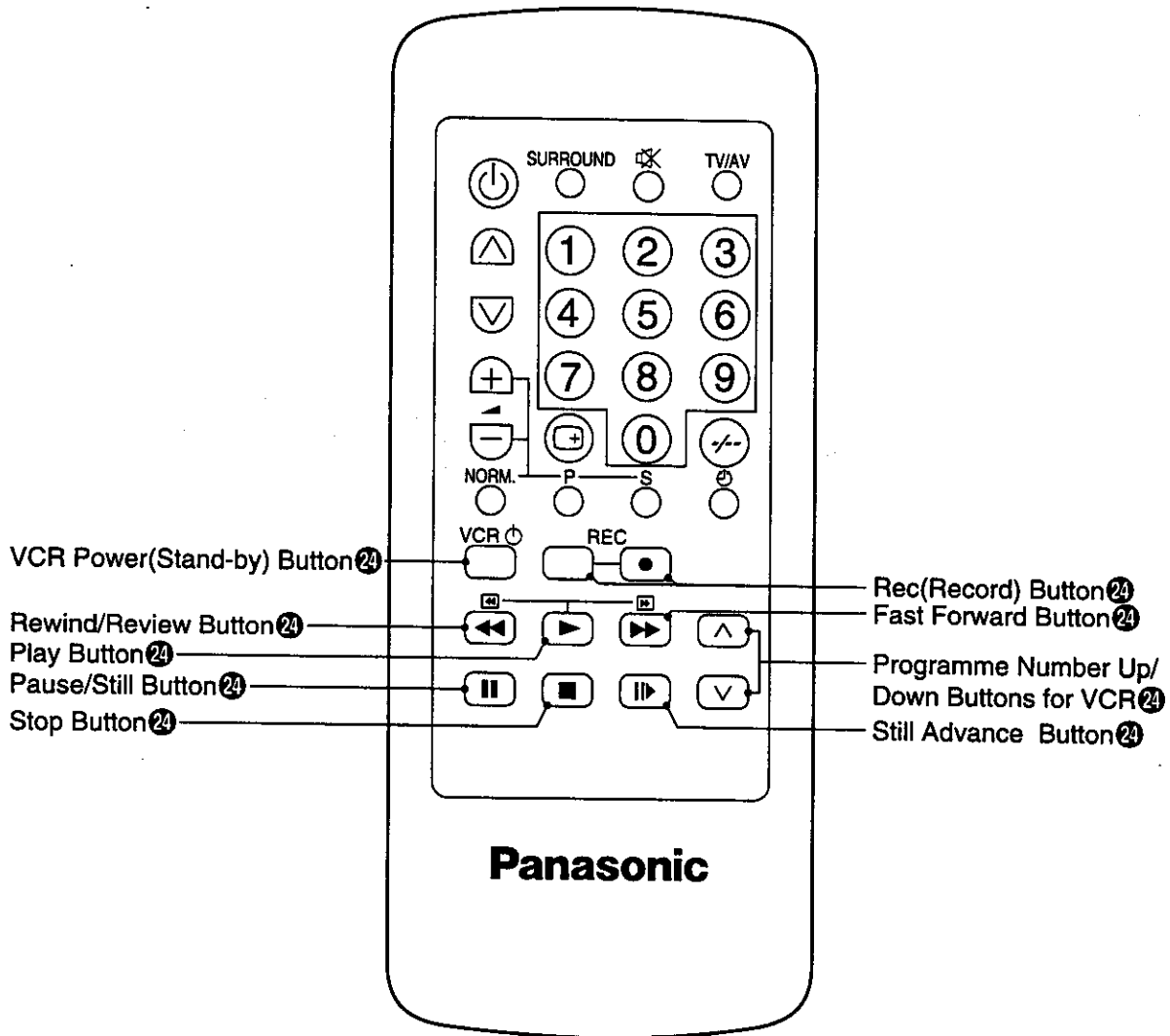

## How to Connect an External Antenna

To obtain the best quality picture and sound, an external antenna, the correct cables (75 Ohm coaxial) and the correct terminating plug will be required.

If a communal antenna system is used, you may require the correct connection cable and plugs between the wall antenna socket and your television receiver.

Your local Television Service Dealer may be able to assist you in obtaining the correct antenna system for your particular area and accessories required.

Any matters about antenna installation, upgrading of existing systems or accessories required, and the cost incurred, are the responsibility of the customer.

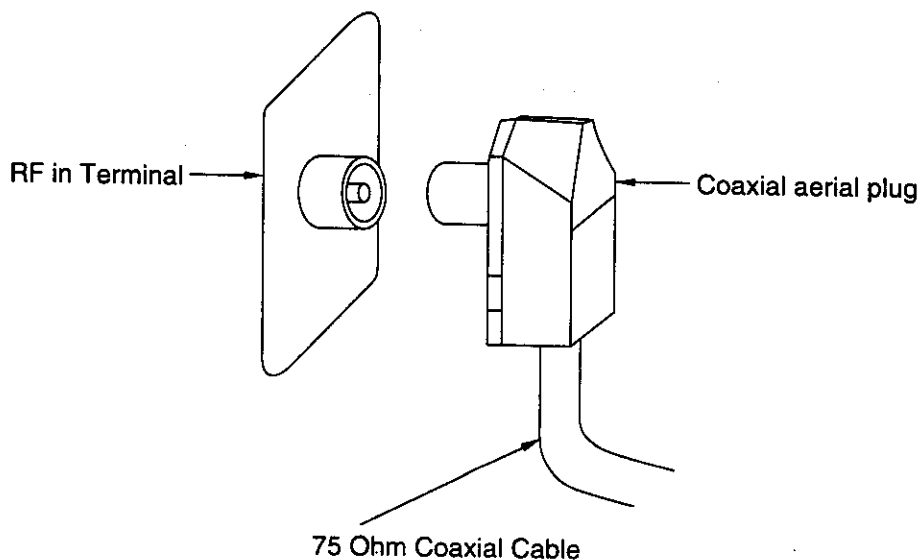

# Connections ( Audio and Video Terminals )

Connect the AV 1 and AV2 (VIDEO and AUDIO terminals) on the TV set with playback equipments as follows:

e.g. To connect the AV1 with playback equipments.

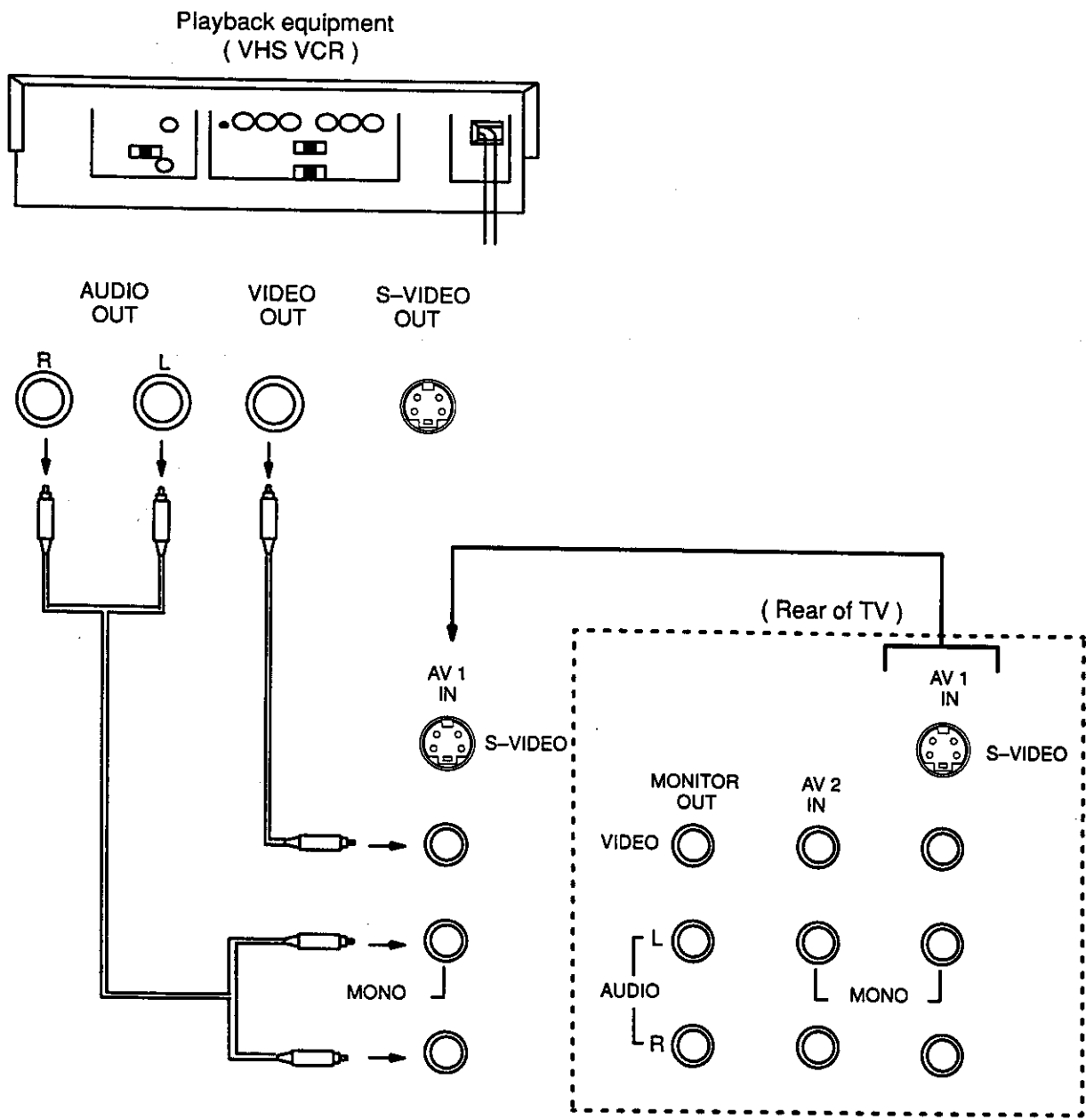

# Connections ( Audio and S-Video Terminals )

Connect the AV 1 (AUDIO and S-VIDEO terminals) on the TV set with playback equipments as follows:

e.g. To connect the AV1 with S VHS VCR.

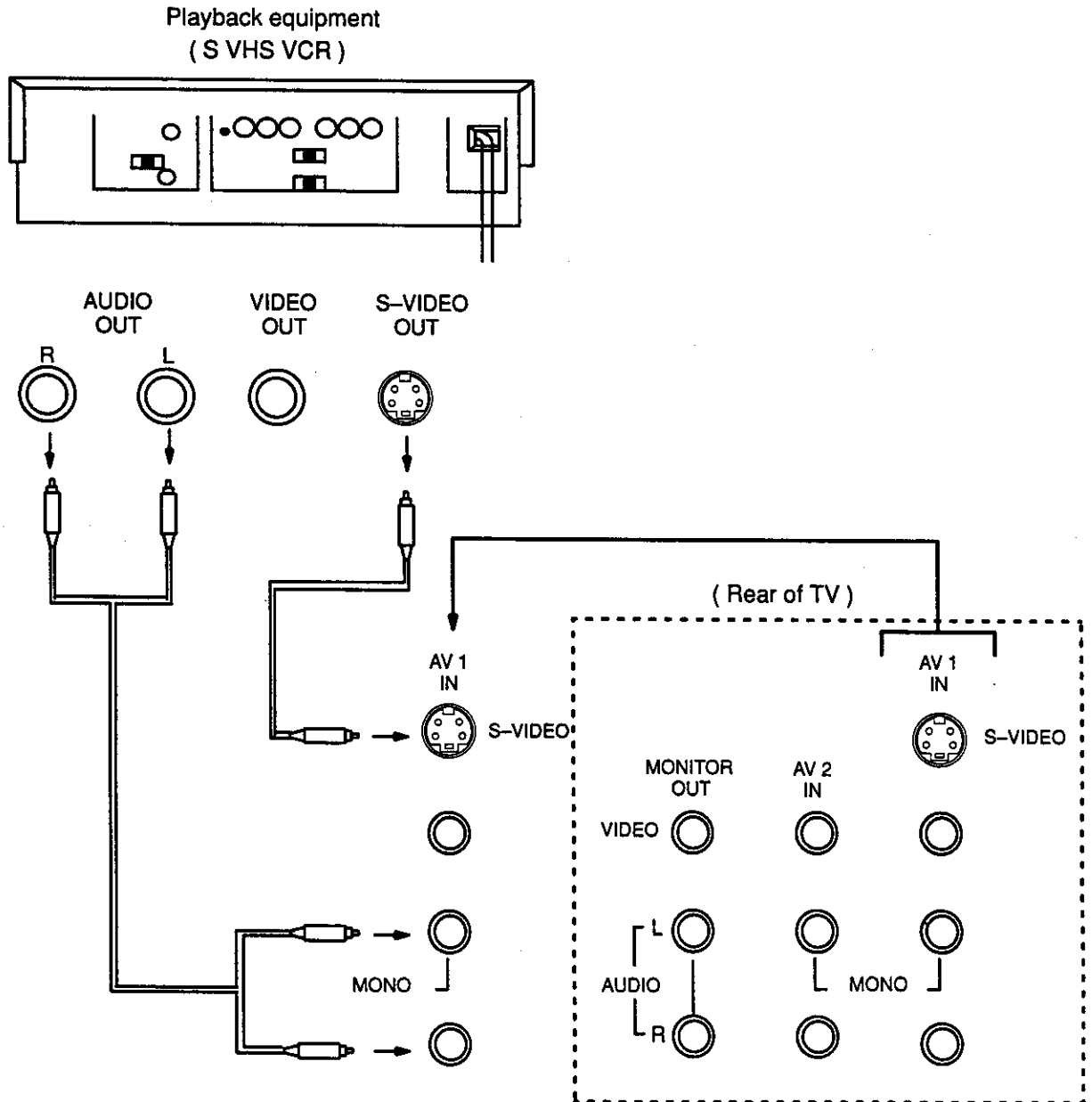

## Connections ( Audio, Video and S-Video Terminals )

Connect the AUDIO, VIDEO and S-VIDEO ( e.g. via AV1 Terminals ) as follows :

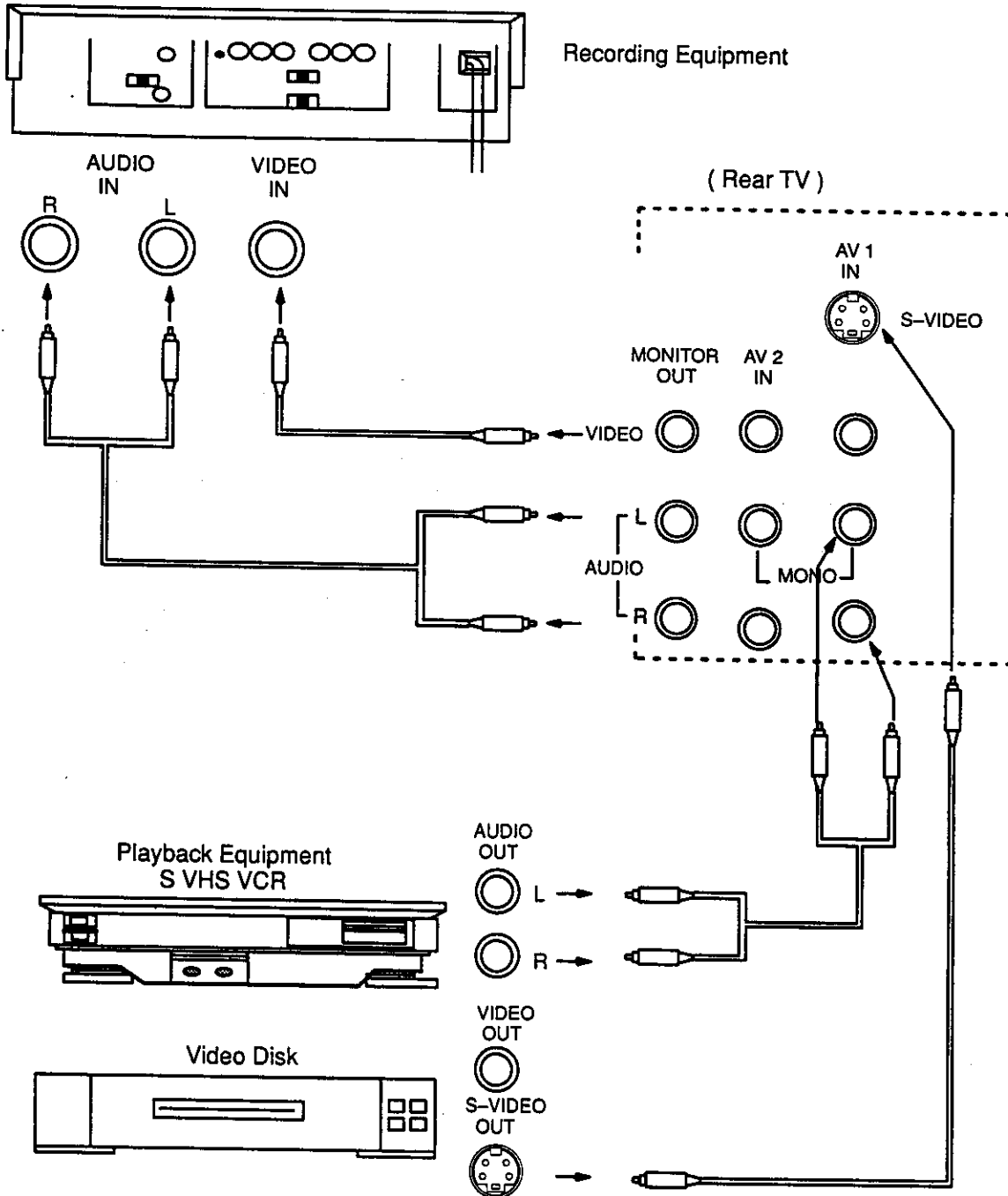

Note :

1. Never connect the same video recorder with both the VIDEO IN and VIDEO OUT Terminals on the TV set, as this could cause incorrect operation.
2. \*MONITOR OUT\* Terminals contain signal which are on the TV screen at that time, e.g. TV programmes or signal from AV2 input.

# Tuning Procedure

## How to Tune in Your TV Set ( Automatic Search )

1. The TV set must be turned on.



2. Press the "PRE." button until the on-screen display appears as follows :

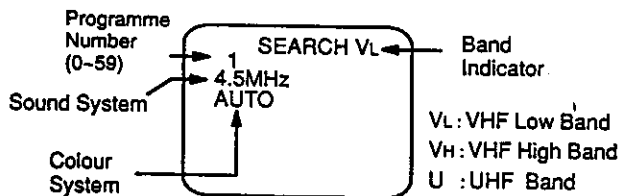
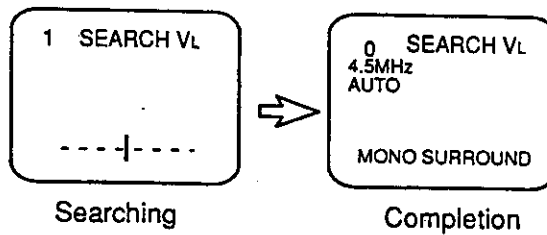

Figure 1.



3. Press the "FUNCTION" button .  
The on-screen display appears as shown :



The best tuning position is automatically memorized.

4. Press the "PRE." button twice to return the TV set to the normal operating mode.

A maximum of 60 Programme Numbers (0-59) can be programmed.

Note:

When the colour or sound is not clear is produced on a Programme Number, press the "SYSTEM I or II" Button. (Refer to page 17)

## How to Tune in Your TV Set ( Manual Search )

1. The TV set must be turned on.



2. Press the "PRE." button until the on-screen display appears as shown in Figure 1.



3. Press either the Programme Number Up "∧" or Down "∨" Button, to select the Programme Number in which you wish to store the desired broadcast transmission channel tuning.

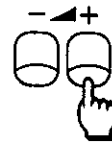

4. Press either the Level Adjustment Up " + " or Down " - " buttons, the TV station broadcasting on the next higher or lower frequency will be automatically tuned and memorized.

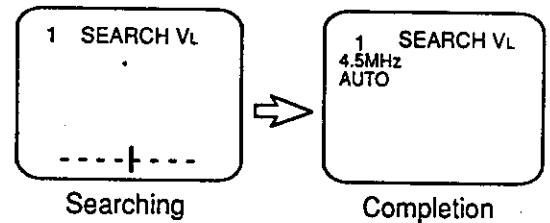

If an undesired TV station is received, press the same button again until the desired TV station is tuned.

5. Repeat step 3 and 4 to tune all the available TV stations on the remaining channel.

Ensure that a new programme number is set ( step 2 ) before tuning the next station.

6. Press the "PRE." button twice to return the TV set to the normal operating mode.

# Fine Tuning Operation

Under normal reception condition, this function is not used. However, in areas of poor reception or constant interference, a slight adjustment on the fine tuning can improve the picture and sound quality.

## How to set the Fine Tuning Operation



1. Press the "PRE." button twice.  
The on-screen will appear as shown :

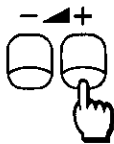
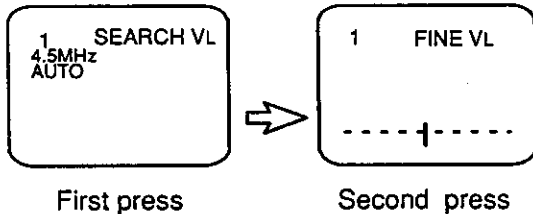

2. Press either the Level Adjustment Up "+" or Down "-" button (Volume Button) continuously.

When the above fine tuning operation has been performed, the "■" symbol appear on the left of Programme Number. The AFC function is deactivated.

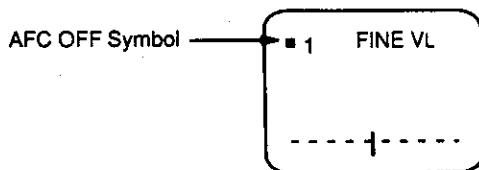

3. Press the "PRE." button once to return the TV set to the normal operating mode.

## How to Cancel the Fine Tuning Operation

These procedure is used when to reset the Programme Number to the automatically tuned condition with the AFC activated.



1. Press the "PRE." button once.  
The on-screen will appear as shown :

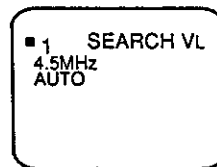

2. Press either the Level Adjustment Up "+" or Down "-" button (Volume Button).

3. Press the "PRE." button twice.

# General Operation on the TV Set

## 1. TV / AV Selection Button



Press the button to select the TV mode, AV1 mode, or AV2 mode.

The sequence is as below :

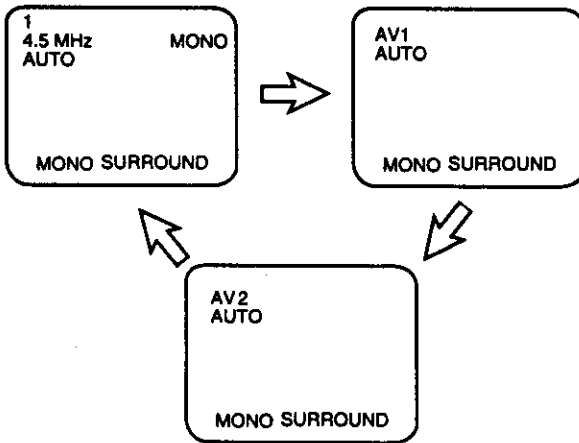

Note :

When TV mode is selected, the last Programme Number, Sound System, Colour System, Surround mode and Sound output ( depending on type of broadcasting transmission ) mode will appear.

When AV mode is selected, the last AV mode, Colour System and Surround mode will appear.

If the S-Video cable is connected to S-Video Terminal (for AV1 only) the selected AV mode, S-Video symbol "S" (AV1 only) will appear on the screen.

e.g. S-Video cable is connected to S-Video terminal and AV1 is selected.

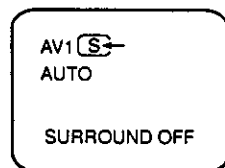

## 2. Volume Up / Down Button



Press these buttons to adjust the sound level.

These buttons also can be used for level Up or Down adjustment in the Picture Control Function mode and Sound Control Function mode.

## 3. Programme Number Up / Down Buttons



Press these buttons to select next higher or next lower Programme Number.

## 4. Preset ( PRE. ) Button



Please refer to pages 14~15 about this button.



# General Operation on the TV Set

## 5. Function ( FUNC. ) Button



By pushing this button repeatedly, the Picture Control Function and Sound Control Function will be displayed.

All functions are set at factory preset level ( is showed in yellow colour ).

Press the Volume Up " + " or Down " - " buttons to adjust the level of selected functions.

The sequence is as follows :

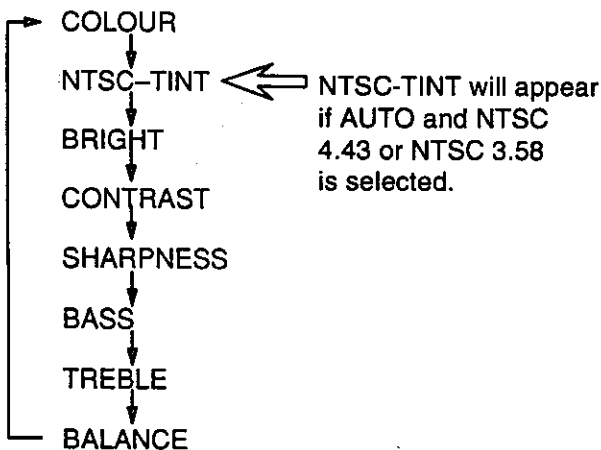

The System button is automatically set to the AUTO mode. If a clear picture cannot be obtained when receiving broadcast or AV signal, push this button repeatedly until the optimum picture is received. Push System I button to the appropriate mode if black and white picture received is shaking slightly. When this button is pushed, you change the on-screen display as shown below :

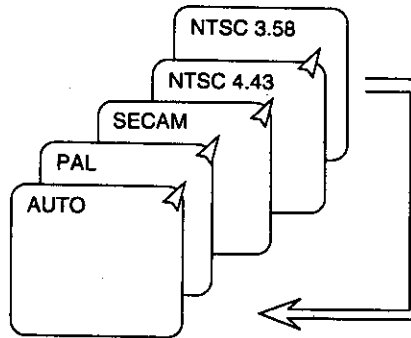

## System II Select Operation ( for TV mode only )

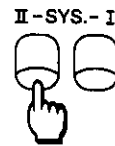

When the sound is not clear or no sound is produced on channel number selected, push this button repeatedly until the optimum sound is obtained. The selected system mode on each channel number position is automatically memorized.

The on-screen change as follows :

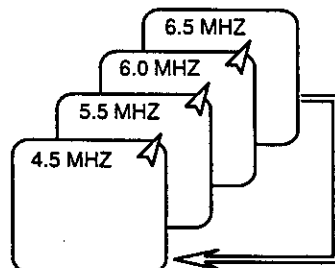

## 6. System Buttons

### System I Select Operation

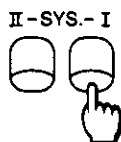

## Remote Control Operation

### 1. Power (Stand-by) Button



Press the button to switch the TV set off.

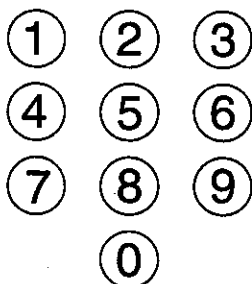

To switch back on perform one of the following :

1. Press Stand-by button again.
2. Press one of these Direct Programme Number Selection buttons on the remote control.
3. Press Programme Number Up / Down buttons on the TV set or on the remote control.

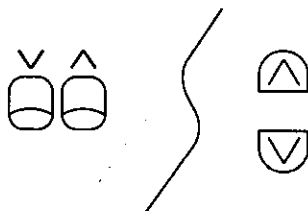

Note :

Do not leave your TV set in stand-by mode for a long period of time. It is better to switch your TV off when you are away.

### 2. Programme Number Up/Down Buttons

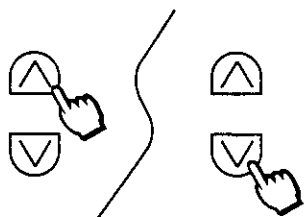

Press these buttons to select next higher or next lower Programme Number.

### 3. Volume Up/Down Buttons

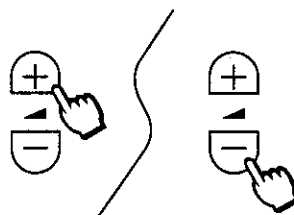

Press these buttons to adjust the sound level.

These buttons also can be used for level Up or Down adjustment in the Picture Control Function mode and Sound Control Function mode.

# Remote Control Operation

## 4. Recall Button



Press the Recall button to activate the on-screen display.

The current Programme Number, Sound System, Colour System, Surround mode and Sound output mode ( depending on type of broadcasting transmission system ) will be displayed on the screen.

After few seconds, the on-screen display of Sound System, Colour System, Surround mode and Sound output will disappear automatically.

Press it again to cancel the current Programme Number.

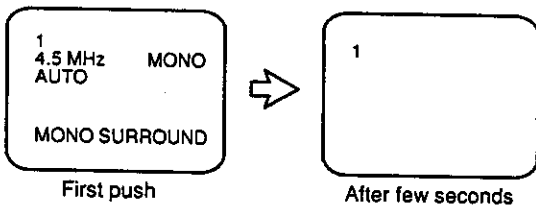

**Note :** In the AV mode, a blue colour screen appear, if there is no AV signal, when the recall function is off.

When this button is pressed, all functions setting are normalized or reset to the factory preset level ( is showed in yellow colour ).

e.g. When this button is pressed after adjusting colour function.

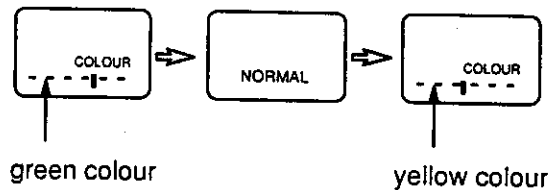

## 6. Picture Control Function (P) Button



By pressing the Picture Control Function button repeatedly, the on-screen display will be changed as shown below.

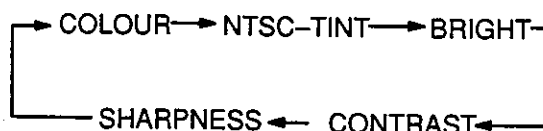

Press the Volume Up " + " or Down " - " buttons during display to adjust the level selected function.

**Note :**

NTSC -TINT will appear on the screen if AUTO and NTSC 4.43 or NTSC 3.58 is selected.

## 5. Normalization (NORM.) Button



This button can be used for setting the Colour, Tint ( Auto, NTSC only ), Brightness, Contrast, Sharpness, Bass, Treble and Balance.

# Remote Control Operation

## 7. Sound Control Function ( S ) Button



By pressing this button, the Sound Control function will be displayed on the factory preset level ( is showed in yellow colour ).

The sequence is as below :

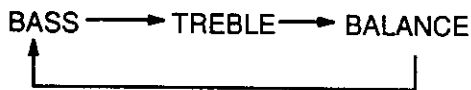

The level can be adjusted by pressing Volume Up " + " or Down " - " buttons.

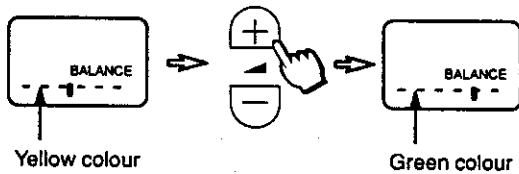

b ) If MONO mode is activated.

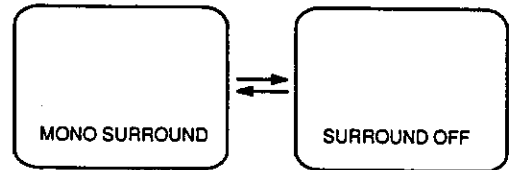

2. VIDEO mode

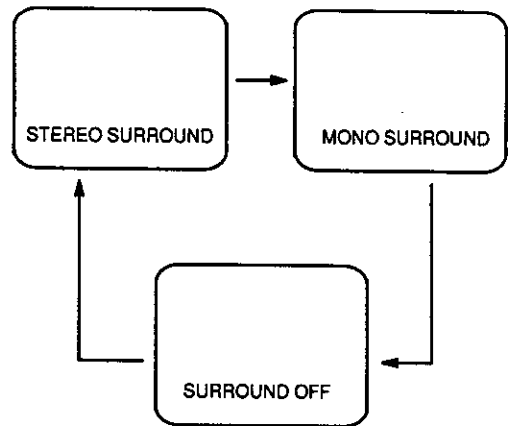

## 8. Surround Button



By pressing this button, the surround effect can be changed. On-screen display as below :

1. TV mode

a ) If STEREO mode is activated.

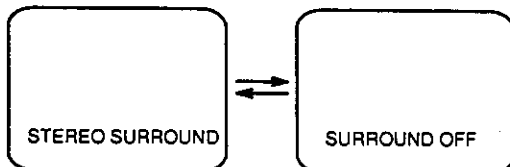

## 9. Sound Mute Button



Press the button to mute sound completely.

To cancel sound mute :

1. Press it again.
2. Press Volume Up " + " or Down " - " buttons.

# Remote Control Operation

## 10. TV/AV Selection Button



Press the button to select the TV mode, AV1 mode or AV2 mode.

The sequence is as below :

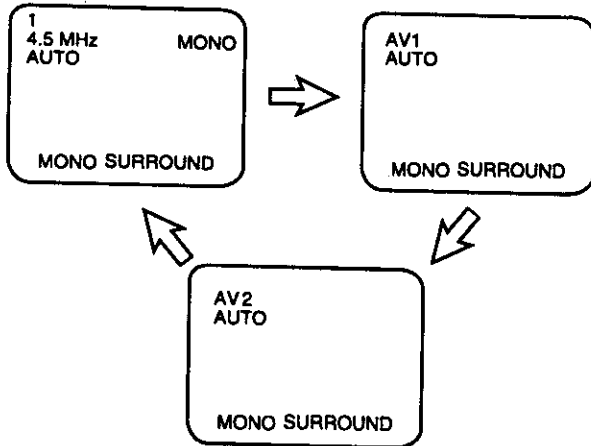

**Note :**  
When TV mode is selected, the last Programme Number, Sound System, Colour System, Surround mode and Sound output ( depending on type of broadcasting transmission ) mode will appear.

When AV mode is selected, the last AV mode, Colour System and Surround mode will appear.

If the S-Video cable is connected to S-Video Terminal (for AV1 only), the selected AV mode, S-Video symbol "S" (AV1 only) will appear on the screen.

e.g. S-Video cable is connected to S-Video terminal and AV1 is selected.

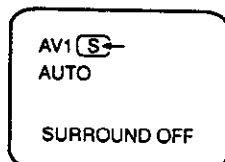

## 11. Direct Programme Number Selection Buttons

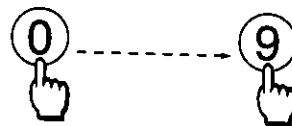

Press one of these buttons to select the required Programme Number between 0 to 9.

## 12. Two Digit Programme Number Selection Button



Press the button and following by the required numbers to select Programme Number from 10 to 59.

e.g. To select Programme Number 12.

1. Press this button once.
2. Press button number " 1 ".
3. Press button number " 2 ".

# Remote Control Operation

## 13. Off-Timer Button



The TV set can be preset to switch off after a fixed period of time.

Press the Off-Timer button will set the TV set for 30 minutes. Press again to set 60 minutes and so on. The selected time will be displayed on the bottom right of the screen.

The sequence is as follows :

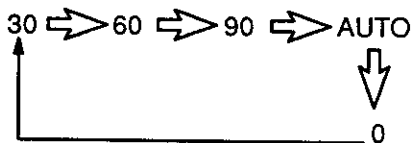

e.g. Setting 30 minutes off-timer.

The selected time disappear after a few seconds and it's will be displayed when the Recall button is pressed. This will give you the remaining time. When the Off-Timer reaches its last 3 minutes, it start blinking before go to stand-by condition.

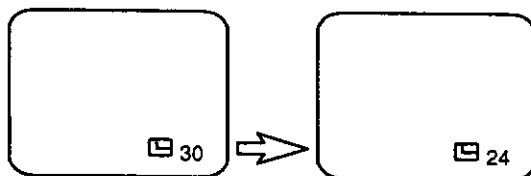

( after 6 minutes )

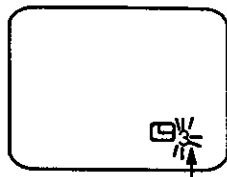

The selected time start blinking at last 3 minutes before stand-by condition.

Note : Setting Off – Timer to AUTO mode.

If the set is not switched off, when the TV station ends broadcasting, it will automatically go to stand-by condition after 5 minutes. This AUTO mode will not operate when the TV receiver is in AV mode.

### How to cancel the off-timer setting

1. Set the pre-set time condition to "0" mode by pushing the "off-timer" button.
2. Turning the TV set off, using the button on the remote control or the power switch button on the TV set.



# VCR Operation

Your Remote Control is designed to be used with selected Panasonic/National VCRs. Some model VCRs have different functions, so please refer to the individual VCR Instruction Booklet to ensure compatibility.

## 1. Power (Stand-by) Button

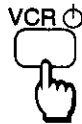

VCR power button.

## 2. Rewind / Review Button



Press to rewind the tape.  
During the playback mode, press this button to view the picture in reverse rapidly.

## 3. Play Button



Press to playback the tape.

## 4. Pause / Still Button



By pressing in playback mode, the tape will be stopped temporarily.  
The picture will pause.

## 5. Stop Button



Press to stop the tape.

## 6. Rec (Record) Button

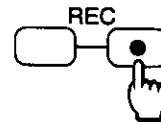

Press these buttons together to record.

## 7. Fast Forward Button



Press to fast forward the tape.  
During the playback mode, press this button to view the picture in forward rapidly.

## 8. Programme Number Up / Down Buttons



Press these buttons to increase or decrease the VCR programme position to tune to a TV station.

## 9. Still Advance Button























While PAUSE / STILL mode, press to advance the picture one frame at a time.



# Troubleshooting

Before calling for service, determine the symptoms and make a few simple checks as shown below.

Symptoms		Checks
Picture	Sound	
 <p>Snowy Picture</p>	 <p>Noisy Sound</p>	<p>Aerial Location, direction Connection</p>
 <p>Multiple Image</p>	 <p>Normal Sound</p>	<p>Aerial Location, direction Connection</p>
 <p>Interference</p>	 <p>Noisy Sound</p>	<p>Electrical Appliances Cars / Motorcycles Fluorescent Lamps</p>
 <p>Normal Picture</p>	 <p>No Sound</p>	<p>Volume (Check whether the mute function has been activated on the Remote Control.)</p>
 <p>No Picture</p>	 <p>No Sound</p>	<p>Not plugged into AC outlet Not switched on Contrast and Brightness / Volume Setting ( Check by pushing the Power Switch or Stand-by Button on the Remote Control. )</p>
 <p>No Colour</p>	 <p>Normal Sound</p>	<p>Colour Control</p>
 <p>Scrambled</p>	 <p>Normal or Weak Sound</p>	<p>Re-tune Channels</p>
 <p>Colour Patches</p>	 <p>Normal Sound</p>	<p>Magnetic interference from unshielded equipment. Receiver moved while "ON".</p>
 <p>No Colour</p>  <p>Rolling Picture</p>  <p>H-Line</p>	 <p>Noisy Sound</p>	<p>System Button</p>

# Specifications

## Power Source

AC Auto 110 ~ 240 V, 50 / 60 Hz  
AC 230 V, 50 Hz (Only for NEW ZEALAND)

## Power Consumption

165 W  
9 W ( Stand-by Condition )

## Receiving System

	System	Function
1 2 3 4 5 6 7	PAL B, G, H PAL I PAL D, K SECAM B, G SECAM D, K SECAM K1 NTSC M (NTSC 3.58 / 4.5MHz)	Reception of broadcasts and Playback from Video Tape Recorders
8 9 10 11 12 13 14	NTSC 4.43 / 5.5MHz NTSC 4.43 / 6.0MHz NTSC 4.43 / 6.5MHz NTSC 3.58 / 5.5MHz NTSC 3.58 / 6.0MHz NTSC 3.58 / 6.5MHz SECAM I	Playback from Special VCR's
15 16 17	PAL 60Hz / 5.5MHz PAL 60Hz / 6.0MHz PAL 60Hz / 6.5MHz	Playback from Special Disc Players and Special VCR's

## Receiving Channels

Regular TV	VHF BAND	
	2 - 12	PAL / SECAM B, K1
	1 - 12	PAL / SECAM D
	0 - 11	PAL B (AUST)
	1 - 9	PAL B (N.Z)
	1 - 12	NTSC M Japan
	2 - 13	NTSC M U.S.A
UHF BAND		
21 - 69	PAL G, H, I/SECAM G, K, K1	
28 - 69	PAL B (AUST)	
13 - 57	PAL D, K	
13 - 62	NTSC M Japan	
14 - 69	NTSC M U.S.A	
CATV	S1 - S20 (OSCAR)	

# Specifications

## Picture Tube

Overall Picture tube measured diagonally	72 cm
Viewable Picture tube measured diagonally	68 cm
CRT Deflection	108°

## Audio Output

5 W (MAX.) × 2

## Aerial Impedance

75 Ω Unbalanced coaxial

## Video / Audio Terminals

AV1	S-Video In	Y: 1.0 Vp-p, 75Ω
		C: 0.3 Vp-p, 75Ω
	Video In	1 Vp-p, 75Ω
AV2	Audio In	Approx. 400 mV
	Video In	1 Vp-p, 75Ω
Monitor Out	Audio In	Approx. 400 mV
	Video Out	1 Vp-p, 75Ω
	Audio Out	Approx. 400 mV

## Accessories Supplied

Remote Control (EUR 641952M)  
R6(AA) Battery × 2

## Dimensions ( W x D x H )

779.4 × 496 × 591 mm

## Weight

40 kg

### Note :

Design and Specifications are subject to change without notice.  
Weight and Dimensions shown are approximate.

## General Information

1. If the set is not switched off when the TV stations stop transmitting at the end of the evening, it will automatically go to stand-by mode after 5 minutes, only in Auto shut-off mode. This function will not operate when the TV is in AV mode.
2. Before calling for service, please refer to the troubleshooting guide on page 25 to determine the symptoms.
3. VCR Mode Select Switch is located on the rear side of the remote control. Please set to "A" when using National/Panasonic VCR. If operation cannot be carried out, set to "B".

### **Customer's Record**

The serial number of this product can be found on its rear cover. You should note the serial number of this unit in the space provided below and retain this book as a permanent record of your purchase to aid in identification in the event of theft or loss.

Model Number **TC-29V50R** \_\_\_\_\_

Serial Number \_\_\_\_\_

---

**Matsushita Electric Industrial Co., Ltd.**

Central P. O. Box 288, Osaka 530-91, Japan

Printed in Japan  
S0694