

Panasonic

Please follow these assembly instructions.

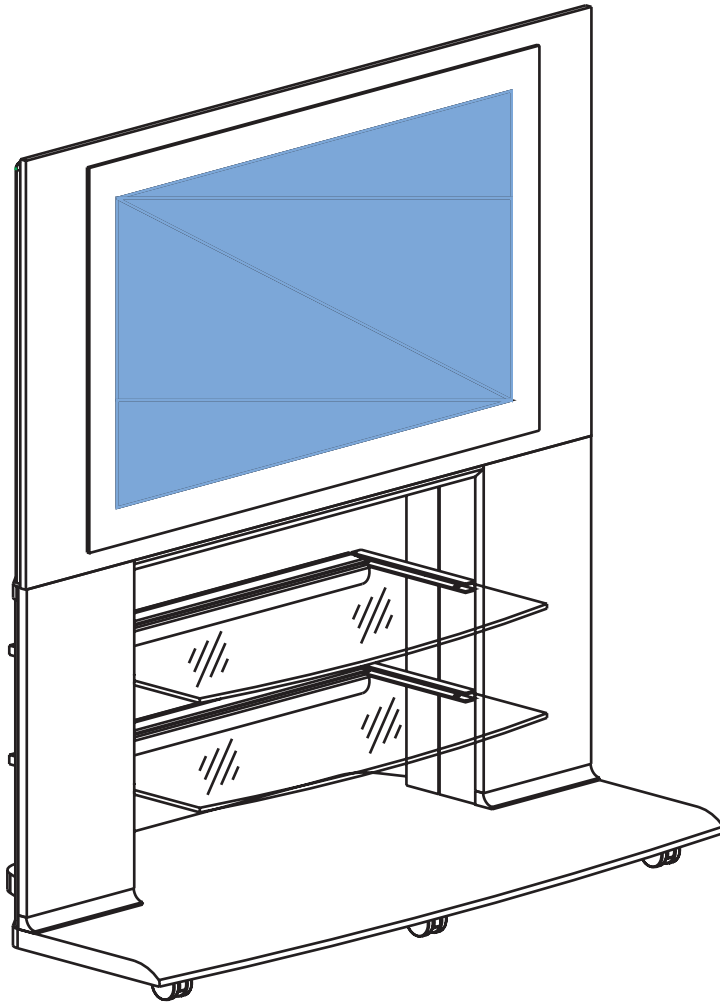

TY-32LX1NZ

BUS4803

Designed specifically for TX-32LX1A

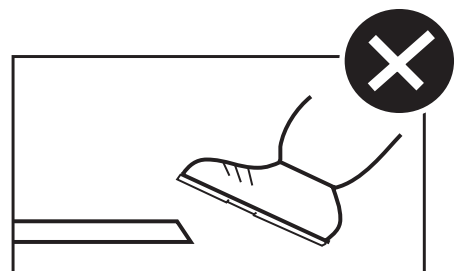
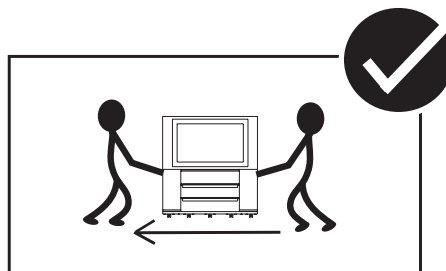
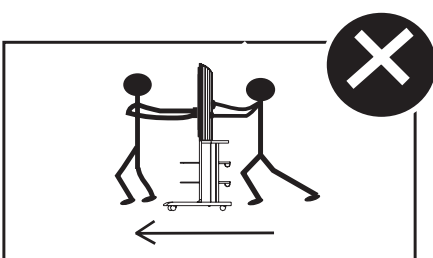

www.panasonic.co.nz

IMPORTANT: DO NOT PUSH OR PULL THE TV TO MOVE THE CABINET

Unpack & Identify Parts

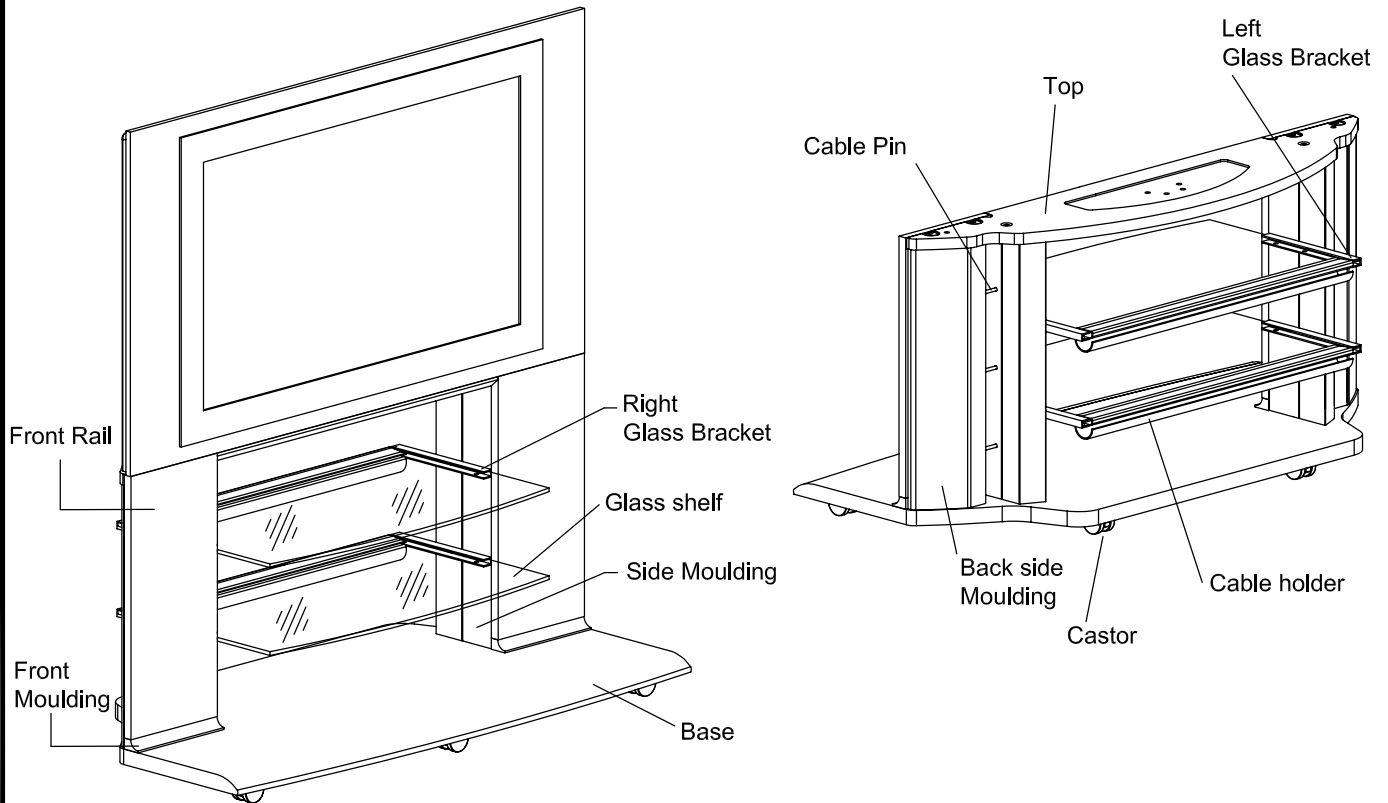

CARTON CONTENTS

<u>Part Description</u>	<u>Quantity</u>	<u>Part Number</u>
Top	1	M19589A1PO
Base	1	M19590A1PO
Front Rail	2	M19591A1PO
Front Mouldings	2	M19595A1PO
Back Side Mouldings	2	M19592A1DF
Side Mouldings	2	M19619A1DF
Glass Shelf	2	PG0299A0
Left Glass Bracket	2	M19596A1PO
Right Glass Bracket	2	M19597A1PO
Castor	5	P815056
Threaded Rod	2	P816172
Cable Holder	2	P816176
Hardware Pack	1	MH1085A0

Customer Service

AUSTRALIA - AFTER SALES SERVICES: CALL - 02 9453 9555
 NEW ZEALAND - CALL 0800 CRITERION (0800 274-837) OR FAX 0800 119-444.

www.criterionfurniture.com

FOR MISSING OR FAULTY PARTS: PLEASE RECHECK YOUR PACKAGING TO ENSURE THAT PARTS ARE MISSING, THEN WRITE OR CALL YOUR CLOSEST SERVICE CENTRE, PROVIDING THE DETAILS BELOW.

1. MODEL NUMBER OF THE UNIT PURCHASED
2. COPY OF YOUR PURCHASE SLIP
3. DESCRIPTION OF THE MISSING PART
4. PART NUMBER OF THE MISSING PART
5. QUANTITY OF THE PARTS MISSING
6. SERIAL NUMBER OF THE UNIT PURCHASED
(LOCATED ON UNDERSIDE OF TOP OF UNIT)

POST DETAILS AS REQUESTED IN 1-6 INCLUSIVE TO:-

CRITERION FURNITURE (NZ) LTD,
 P.O. BOX 58-646,
 GREENMOUNT,
 AUCKLAND 1730,
 NEW ZEALAND.

MAKE SURE YOU INCLUDE YOUR ADDRESS.

IMPORTANT: - MISSING PARTS CANNOT BE REPLACED UNLESS THE INFORMATION REQUESTED ABOVE IS FULLY SUPPLIED.

Hardware Contents:

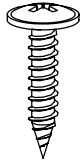

Screw x 10
P860045



Varianta Screw x 8
P860246



Grub Screw x 8
P830013

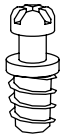

Small Connecting
Rods x 4
P835508

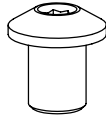

Sleeve Nut x 4
P860256

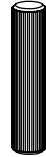

Wooden Dowels x 20
P800201



Cable Pins x 6
P816173



Locking Screws x 4
P860214
(A)

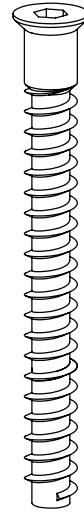

Locking Screws x 2
P860288
(B)

Tools Required:

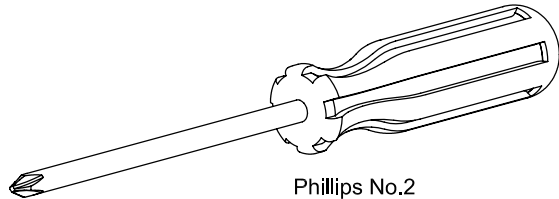

Phillips No.2
Screwdriver



Allen Key x 2
P840004
(Supplied)

STEP 1

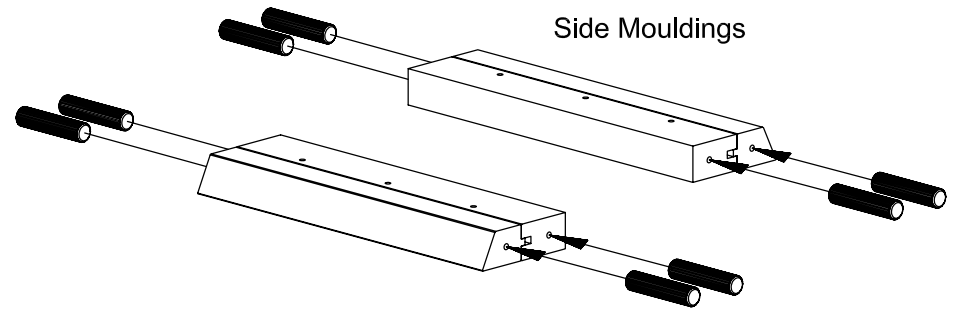
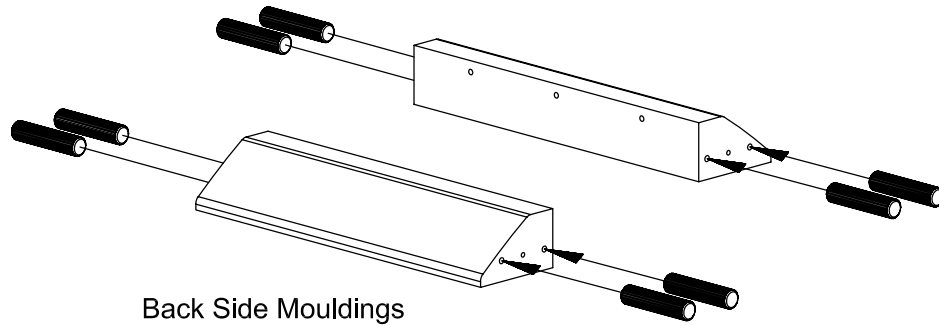
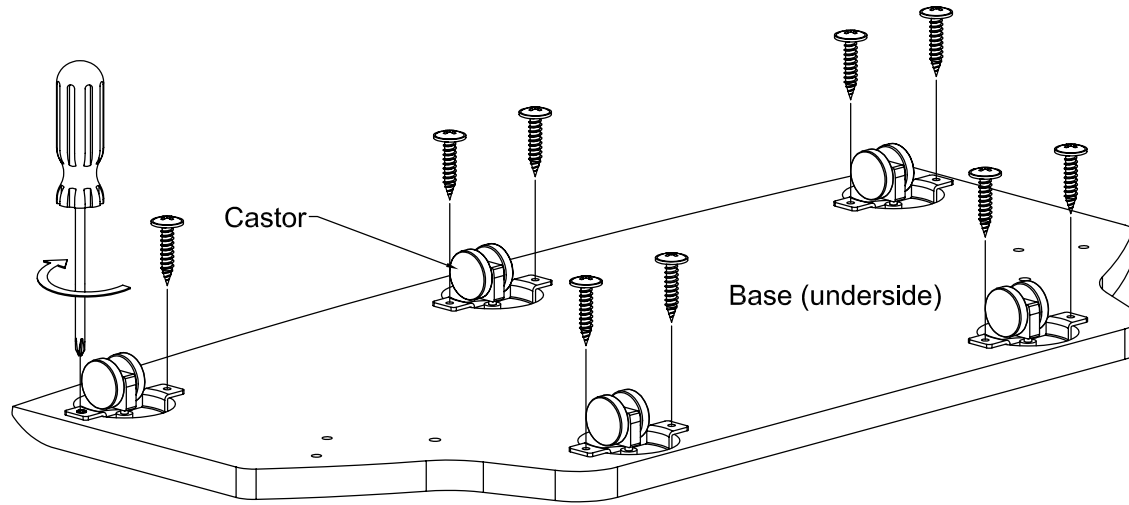
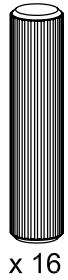

1. Fasten 5 Castors to the Base as shown.
2. Insert Wooden Dowels as shown above.

STEP 2

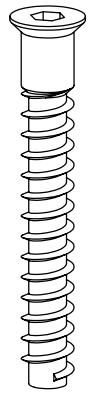

(A)
x 2

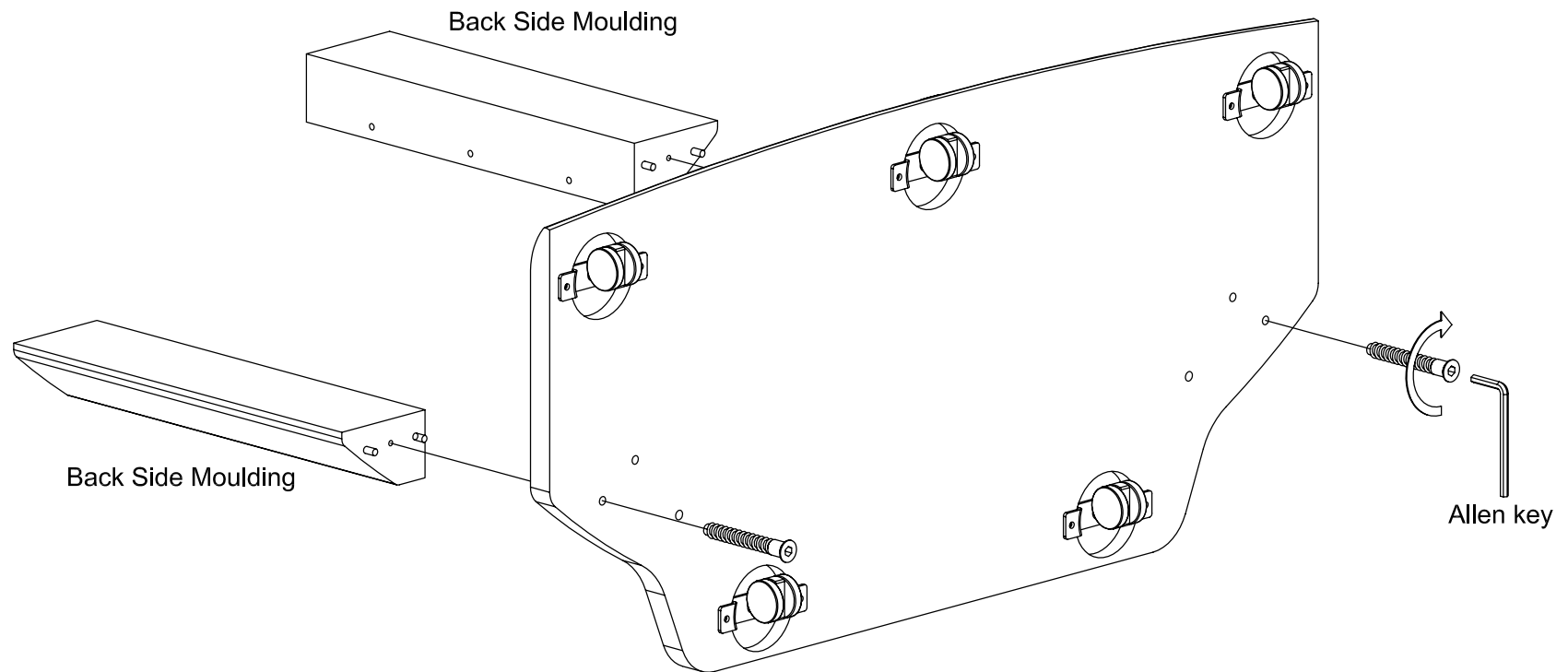

1. Fasten the Back Side Mouldings to the Base as shown.

STEP 3



x 6

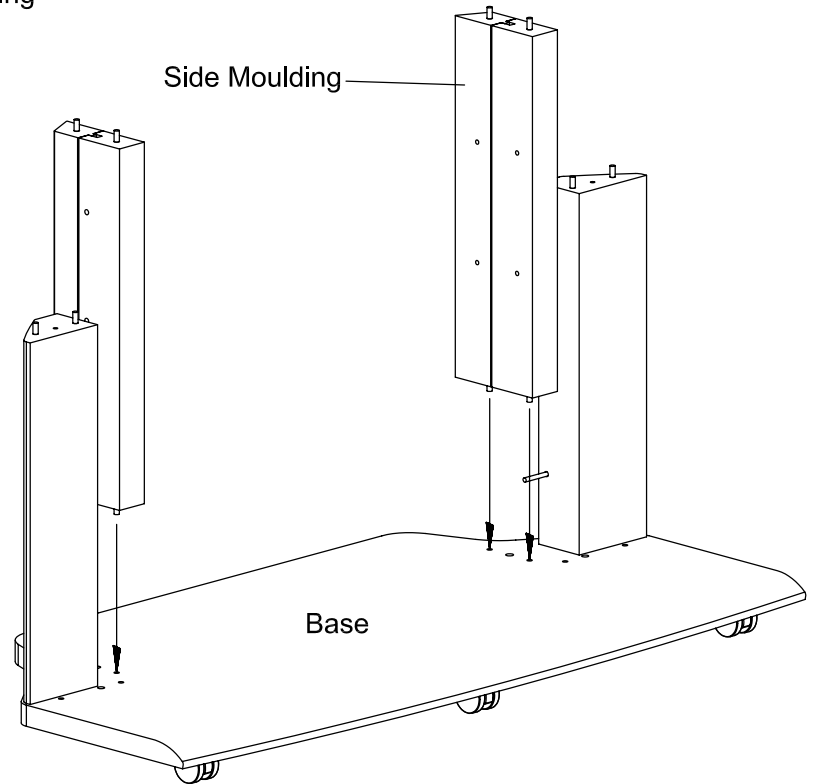
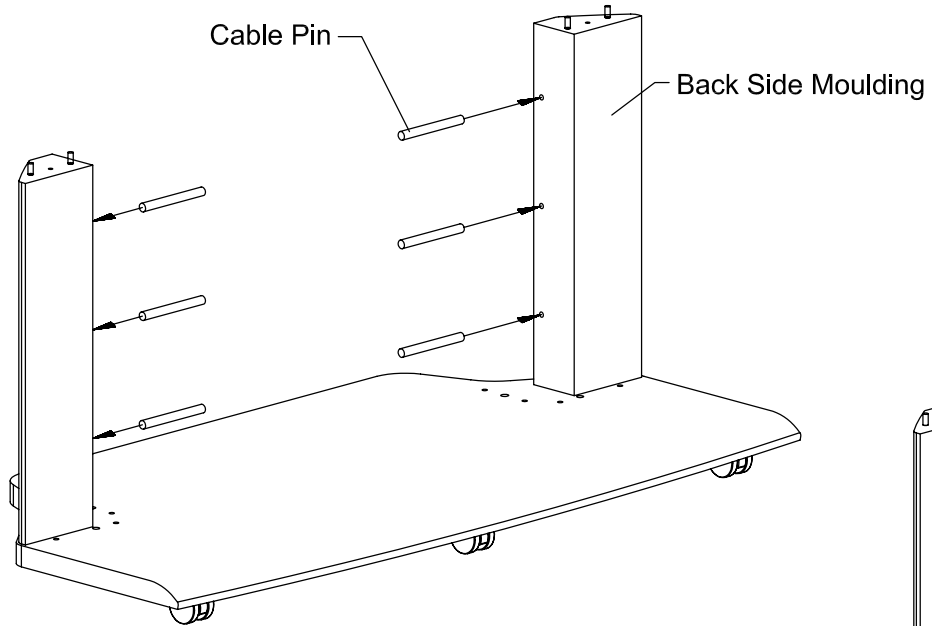

1. Fully insert 6 Cable Pins into the holes in the sides of the Back Side Mouldings as shown.
2. Fit Side Mouldings to the Base as shown.

STEP 4

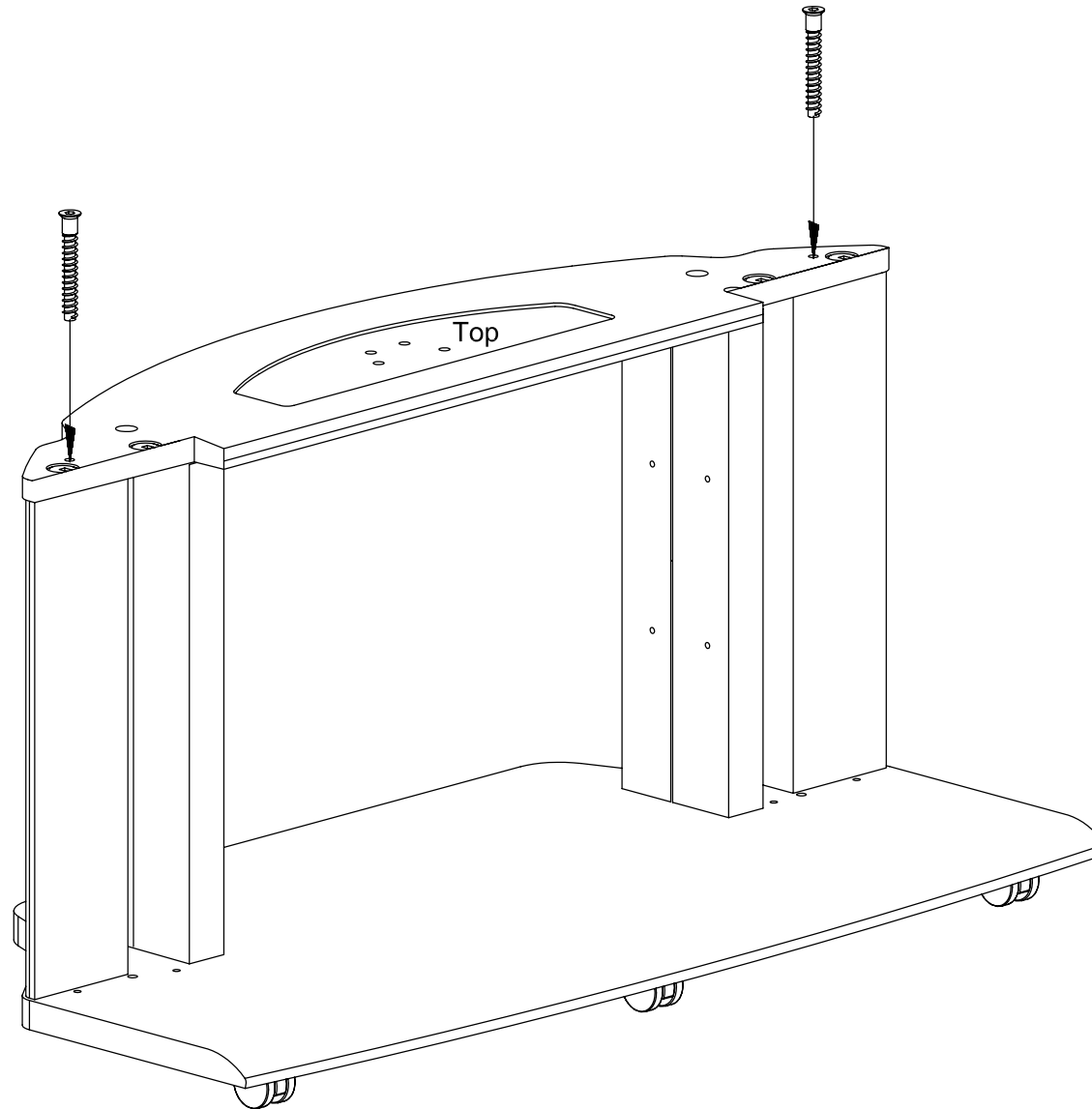
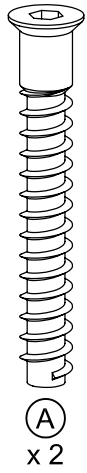

1. Secure Top to Back Side Mouldings with 2 Screws as shown.

STEP 5

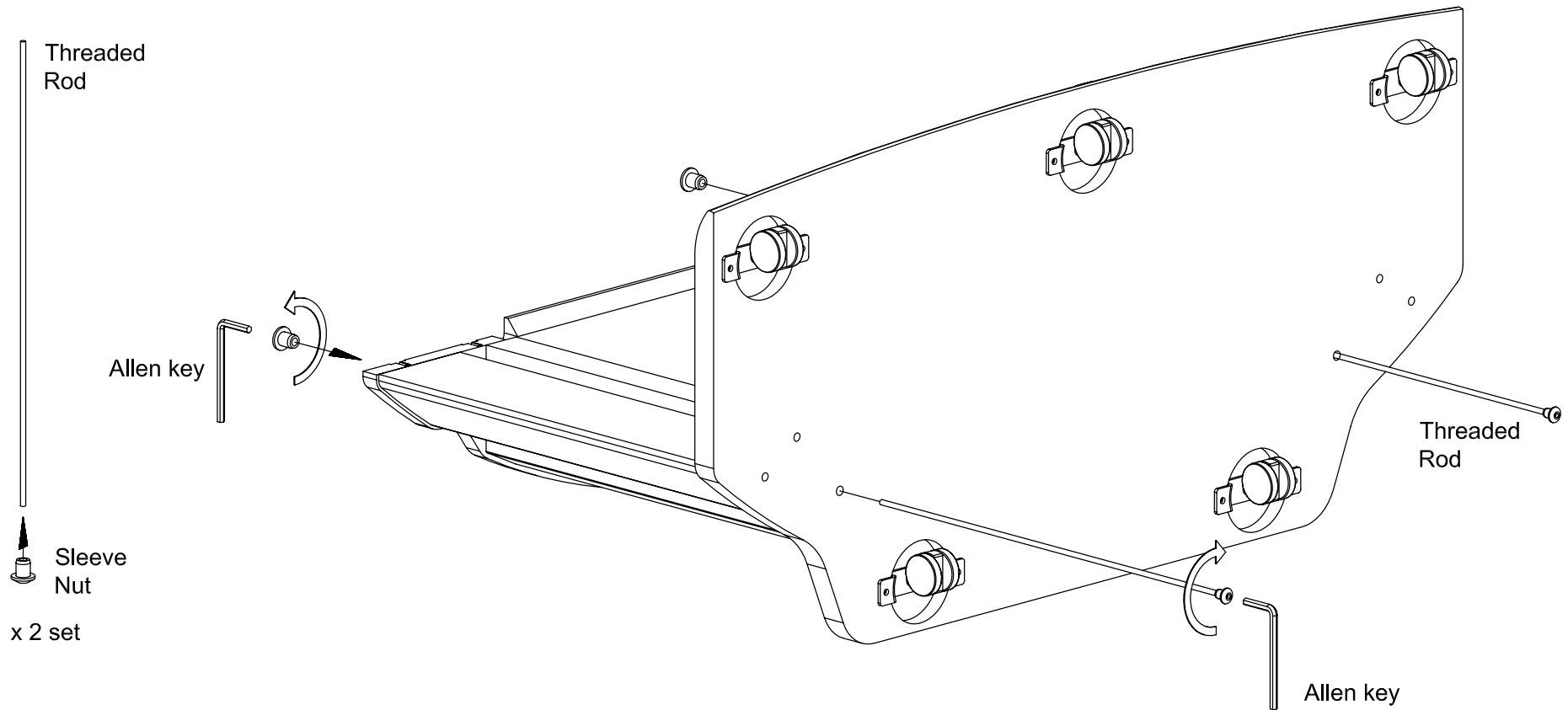

1. Fit Sleeve Nut at one end of each Threaded Rod using an Allen Key.
2. Insert Threaded Rod into Assembly through Base as shown.
3. Fit another Sleeve Nut at other end of Threaded Rod from Top and tighten it turning both Allen Keys in opposite direction of each other.

STEP 6

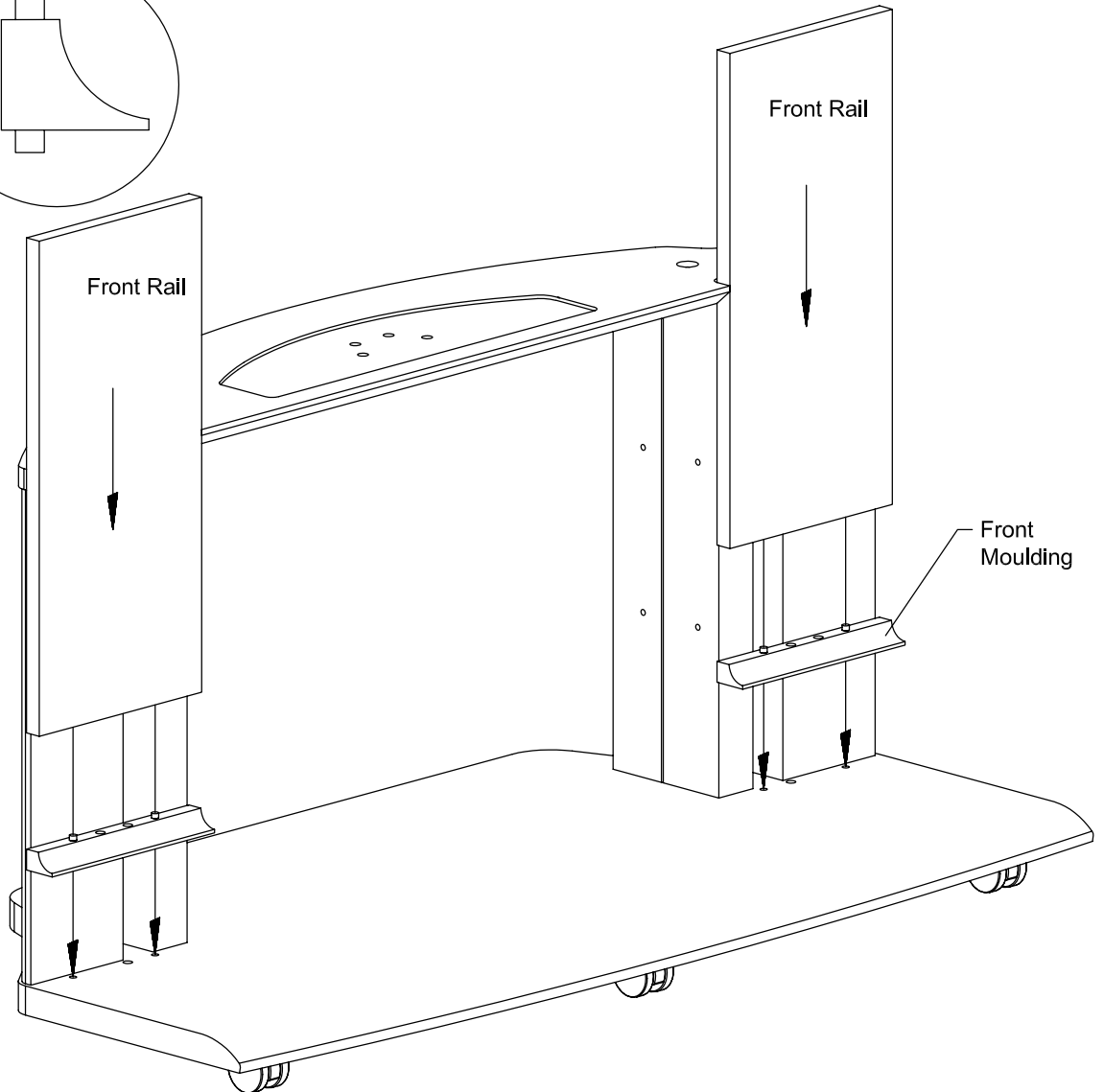
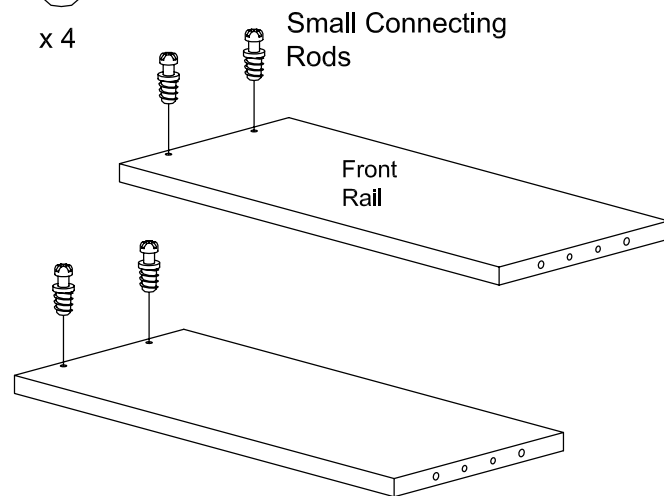
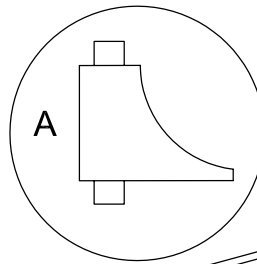
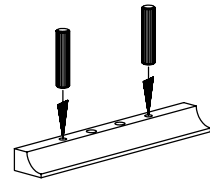
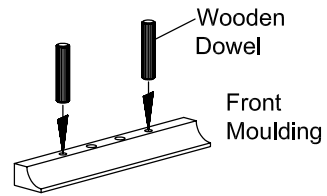
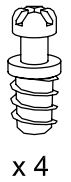
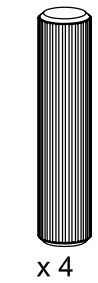

1. Fit 2 Small Connecting Rods to each Front Rail as shown.
2. Insert 2 Wooden Dowels into each of Front Moulding so that the Dowels project equally on both sides, as shown above in A.
3. Fit Front Mouldings to Base as shown.
4. Fit Front Rails on to Front Mouldings as shown.

STEP 7

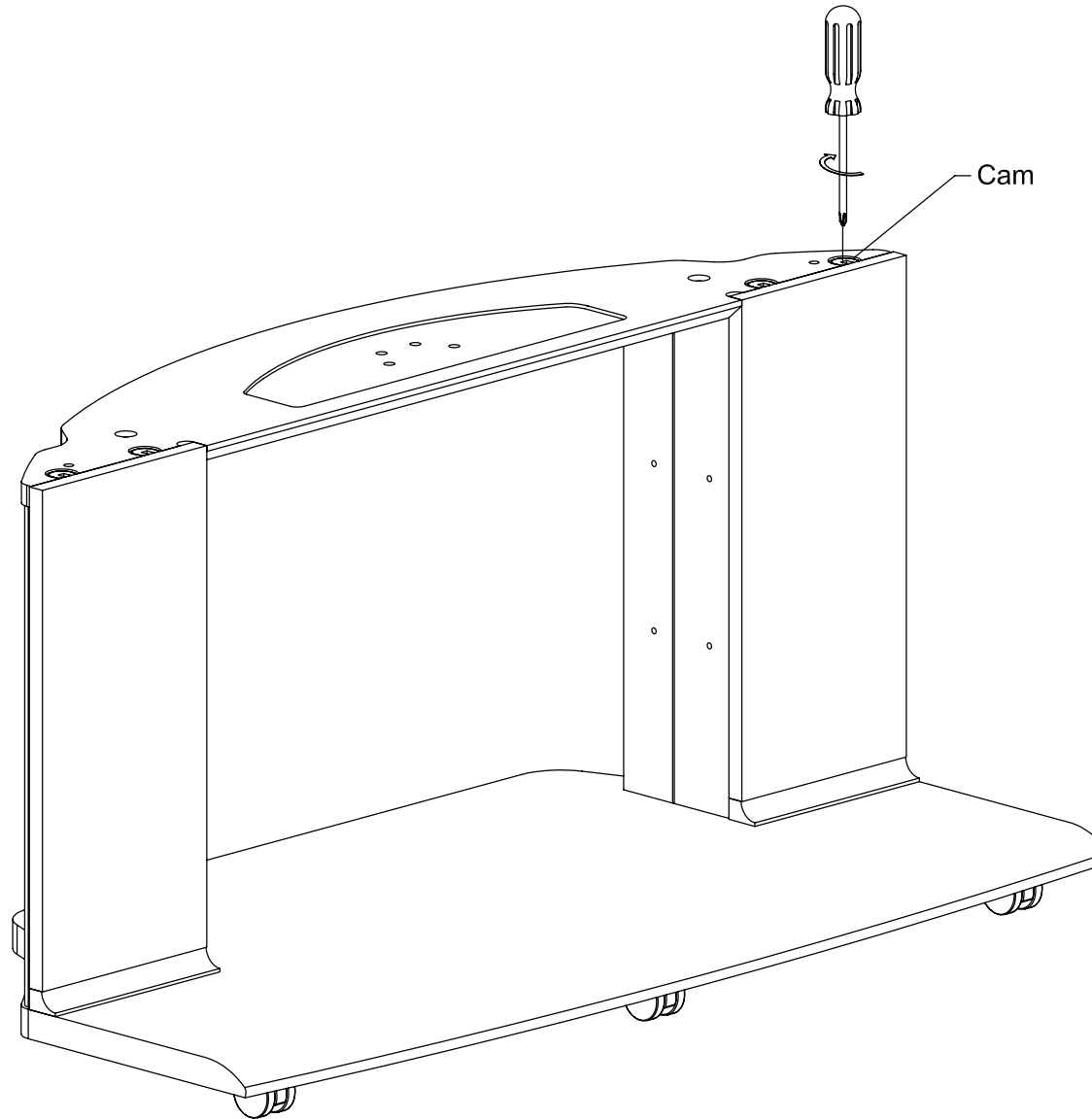

1. Tighten the 4 prefitted Cams in Top, by turning them clockwise.

STEP 8

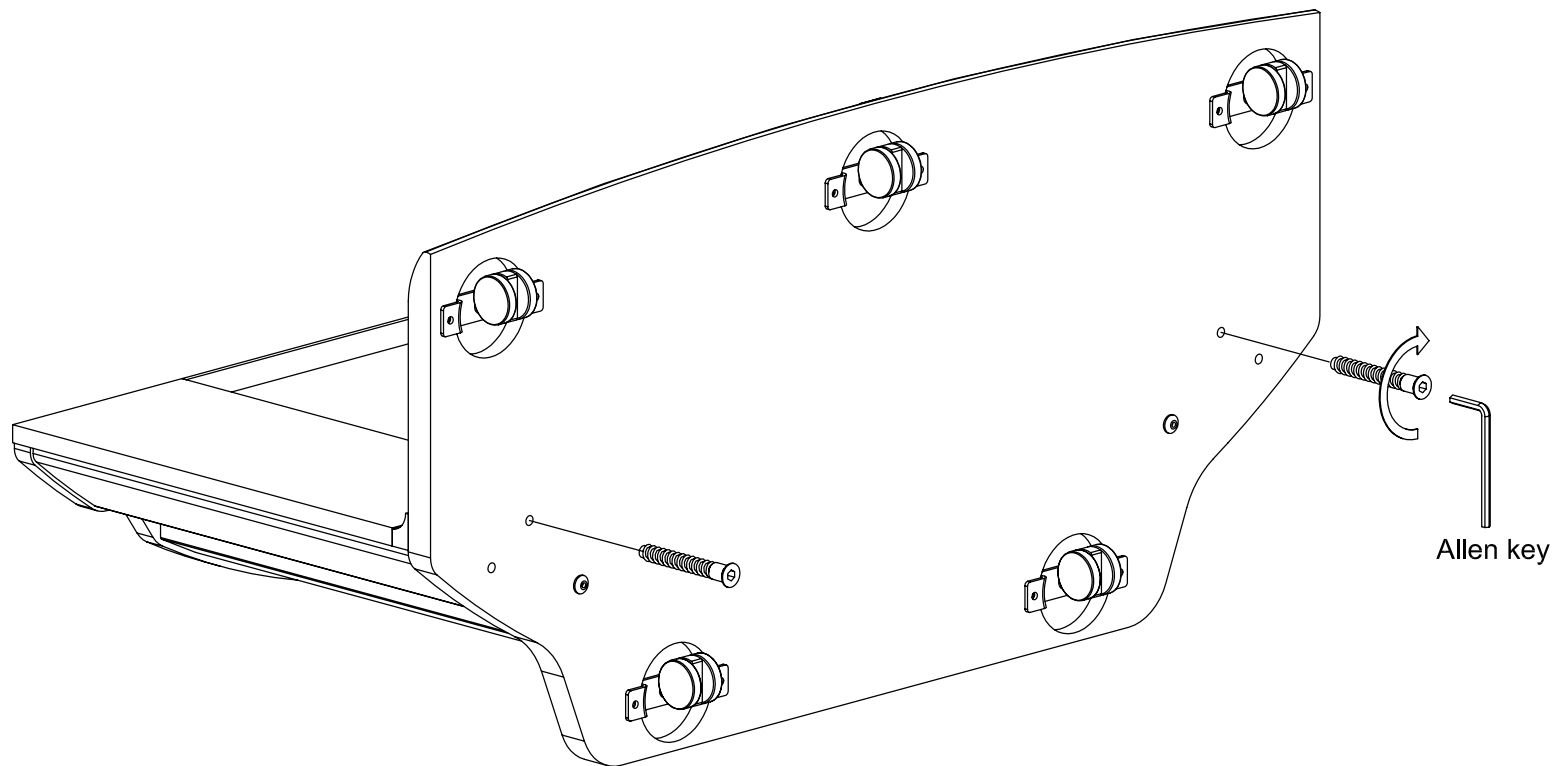
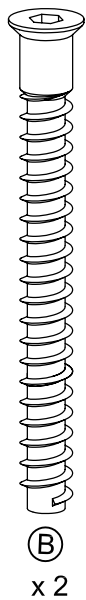

1. Fasten the Front Rails and Front Mouldings to the Base using 2 Locking Screws Ⓑ

STEP 9



x 8

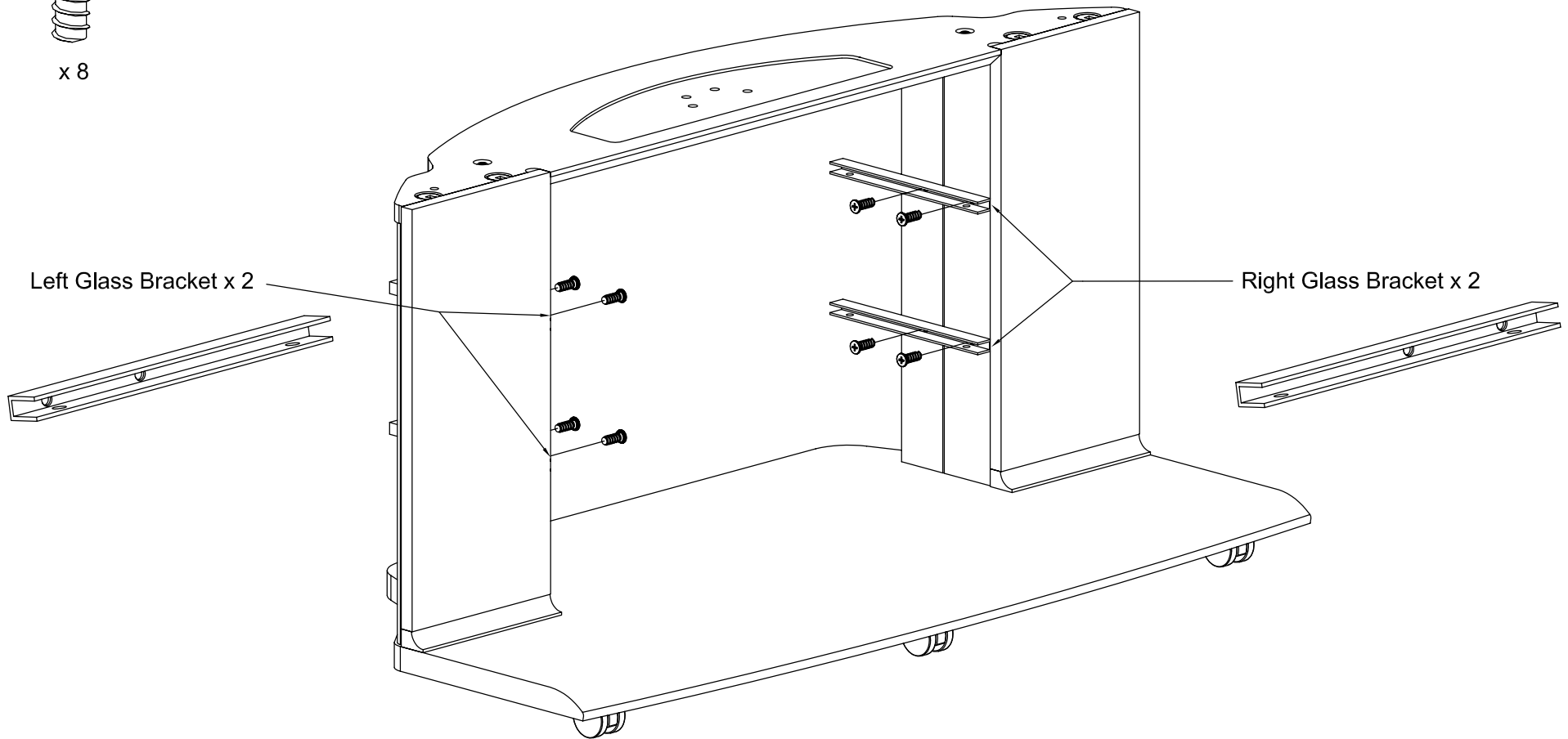

1. Fasten the Glass Brackets to Side Mouldings using Screws as shown.

STEP 10



x 8

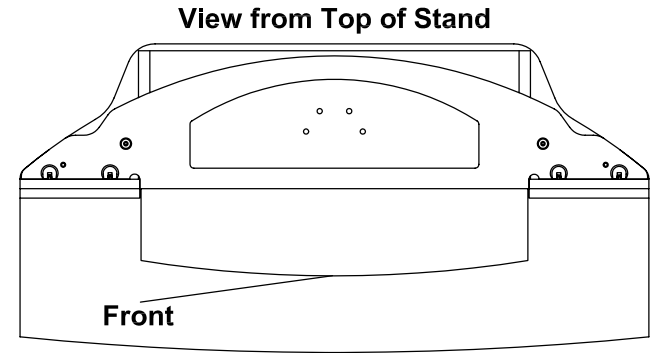
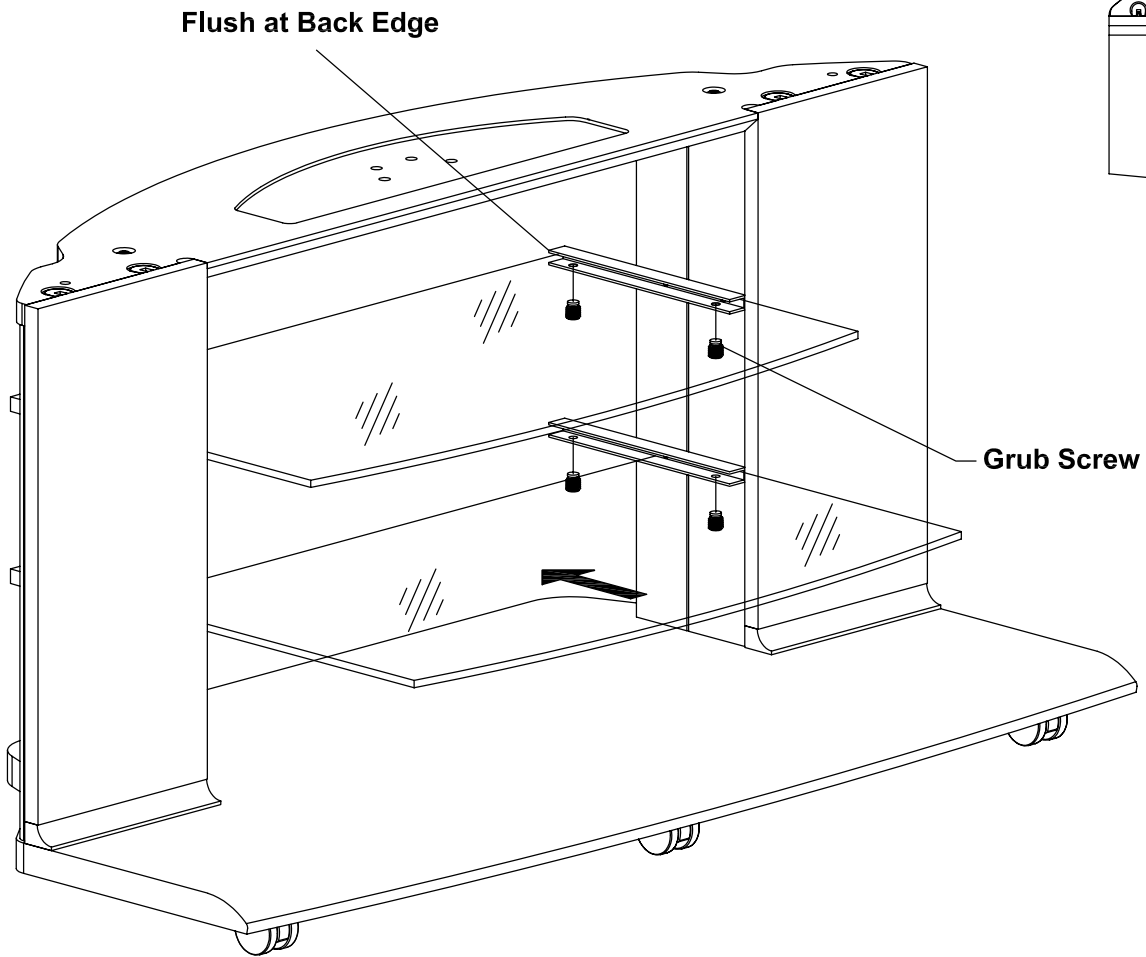

IMPORTANT: Curved Edge of Glass faces Front of Stand.

1. Slide each Glass Shelf into Glass Brackets and tighten Grub Screws from the underside of brackets as shown, make sure the Back Edge of Glass Shelf is flush with Glass Bracket.

STEP 11

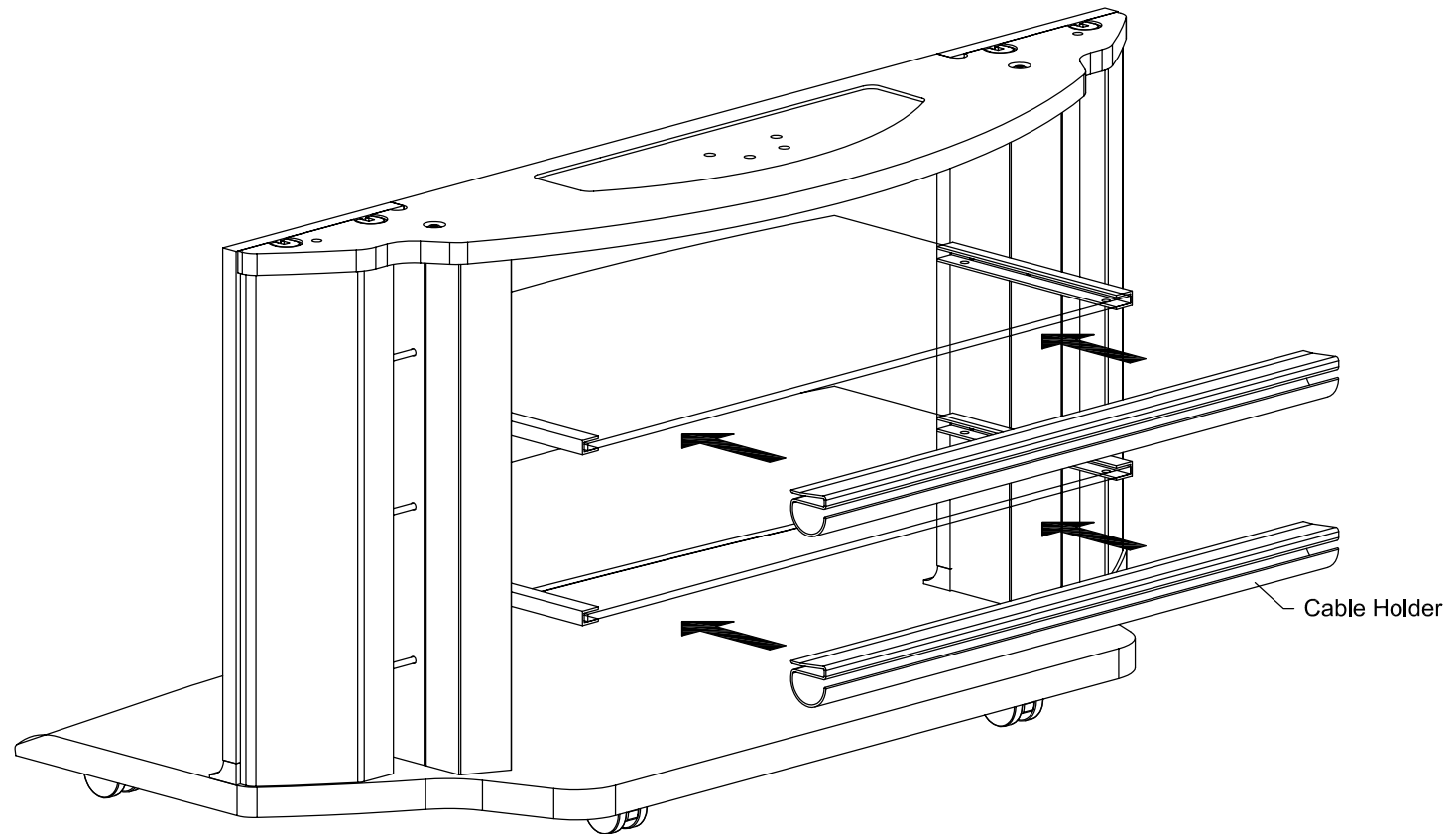

1. Slide fit each Cable Holder onto the Back Edge of each Glass Shelf.

STEP 12

CAUTION: TWO PERSON LIFT.

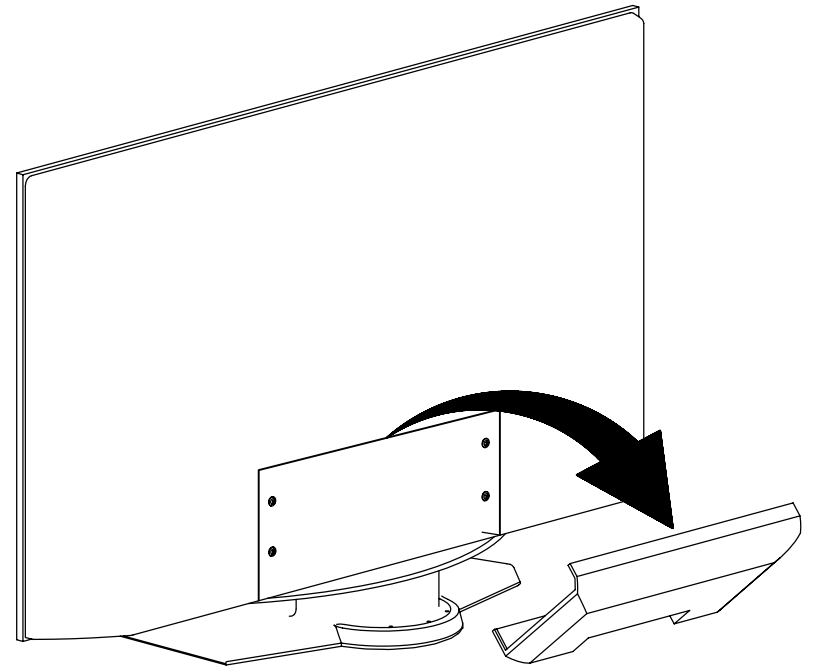
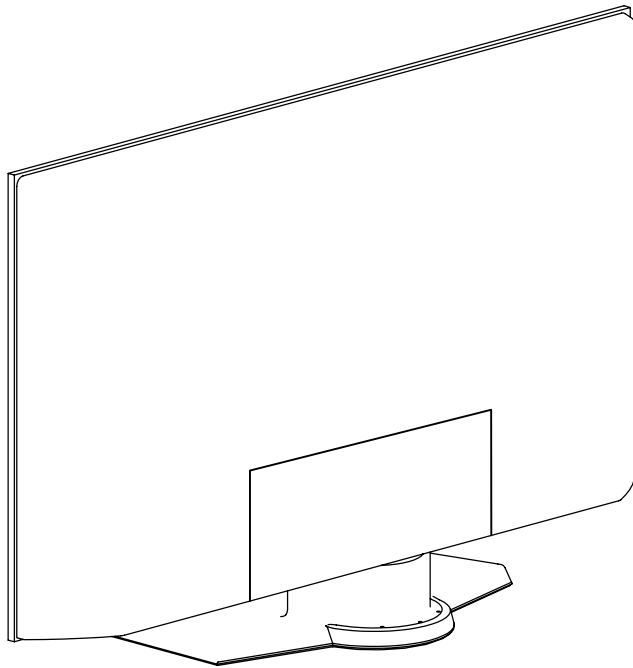

1. Remove the Television from Box. CAUTION: TWO PERSON LIFT.
2. Remove Back Cover of Television to expose 4 Mount Screws.

STEP 13

CAUTION TWO PERSON LIFT.

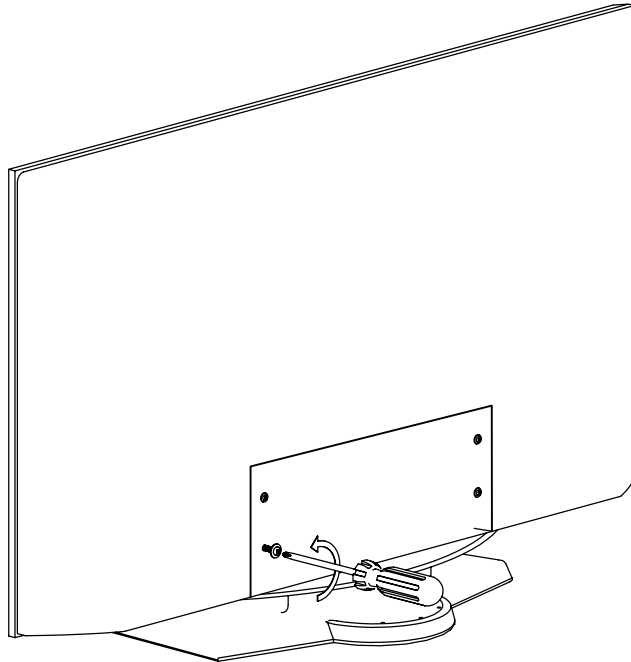

With great care place Television Screen Face up onto a Soft Cloth.

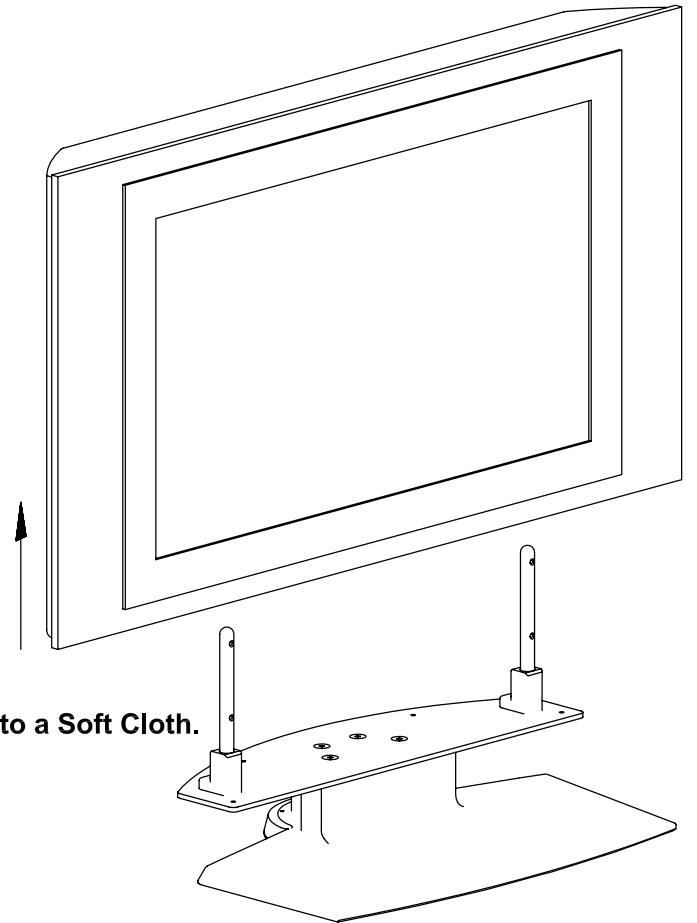

1. Remove 4 Screws from inside of Back Cover as shown.
2. With help of an Assistant lift the Television off Base Unit. **With great care place Television Screen Face up onto a Soft Cloth.**

STEP 14

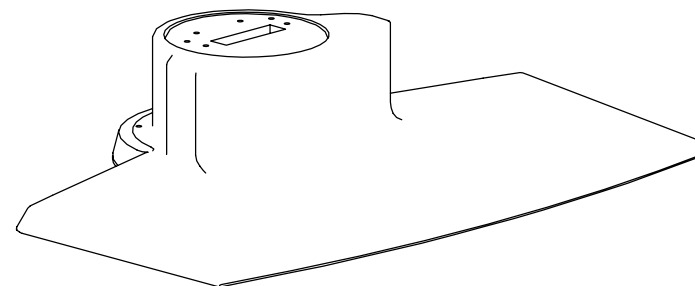
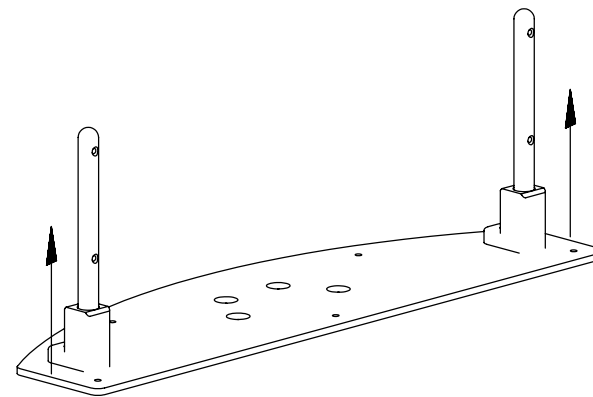
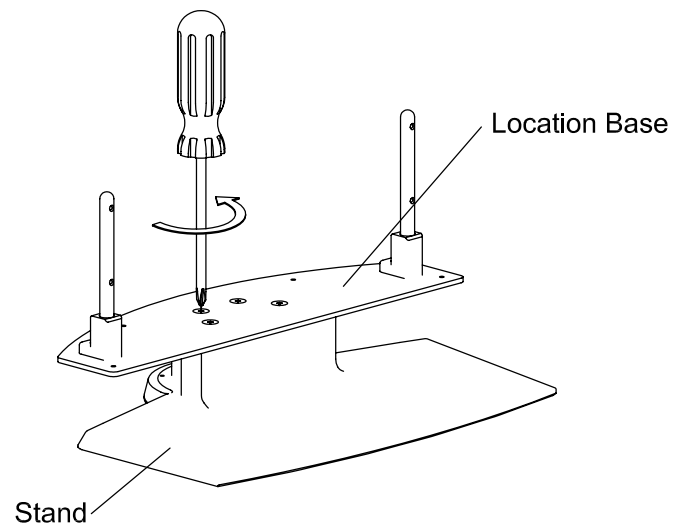

1. Remove 4 Screws from the Location Base as shown.
2. Lift the Location Base off the Stand.

STEP 15

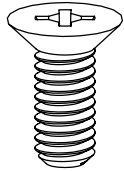

x 4

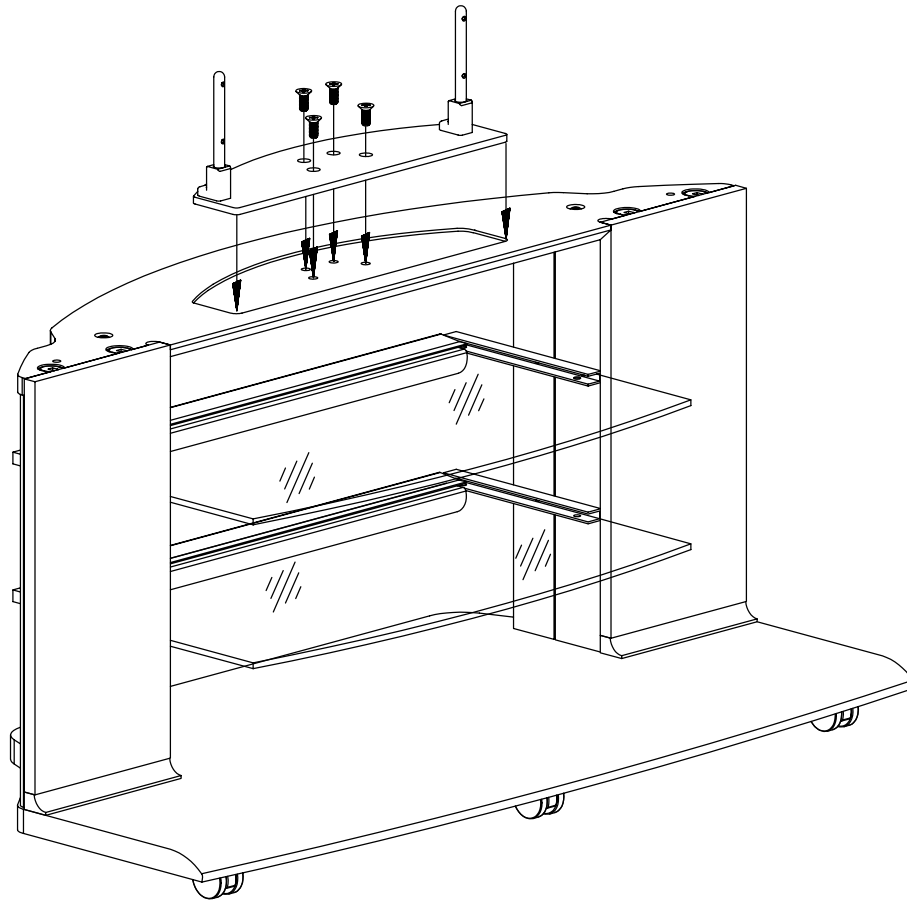

CAUTION TWO PERSON LIFT.

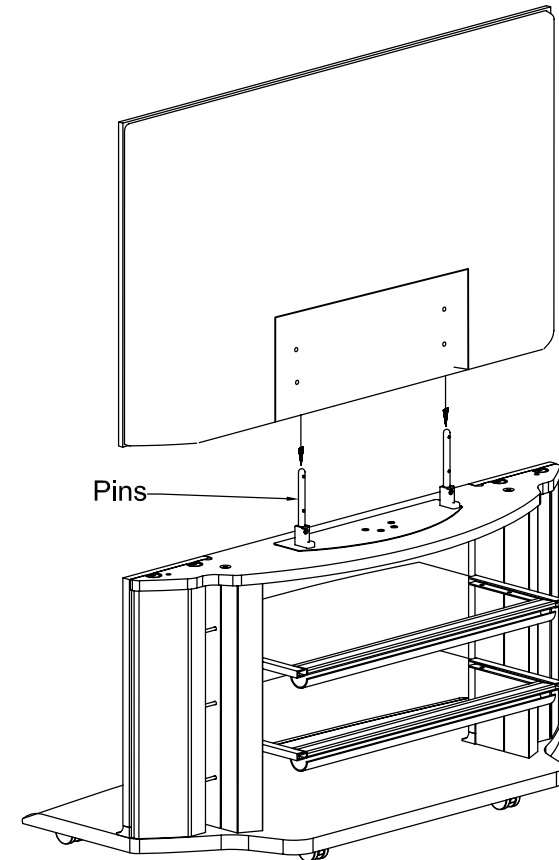

1. Fasten the Location Base to the Top of the Cabinet as shown above using 4 Screws removed during Step 14.
2. With help of an Assistant, lift the Television onto Pins ensuring that the Pins line up with the Holes in base of Television.

STEP 16

CABLE MANAGEMENT

Once Cables are behind Pins, slide the Cable Pins across into the Side Moulding.

Back Side Moulding

Place Cables from Electronic Equipment into Cable Holder.

Side Moulding

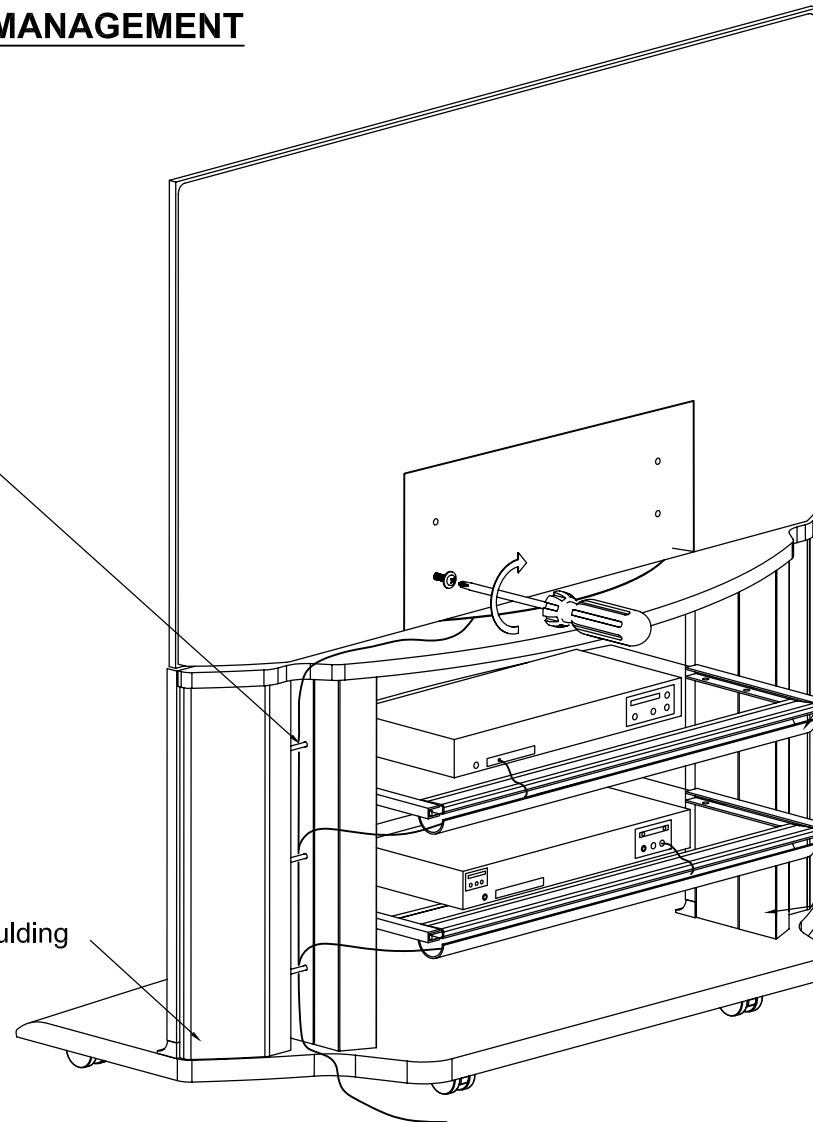

1. Secure the Television to the Cabinet using Screws removed during Step 13.
2. Replace Cover onto Back of Television.
3. With Cable Pins pushed into Back Side Mouldings, place Cables behind pins, then slide Pins across into the Side Mouldings.

Congratulations you have now finished the assembly for your Panasonic Television Stand.