

32" CLASS (31.5" DIAGONAL)

32LG3DC

LCD TV

## LCD Widescreen HDTV with HD-PPV Capability



NATIVE DISPLAY RESOLUTION  
1366 x 768

MPEG-2



DYNAMIC POWER SAVINGS

HD VOD PPV DECRYPTION  
Integrated Pro:Idiom™

BUILT-IN TUNERS  
ATSC/NTSC/QAM Clear

DYNAMIC CONTRAST RATIO  
10,000:1

HIGH BRIGHTNESS  
500 cd/m<sup>2</sup>

LG'S EXCLUSIVE XD ENGINE®

REAL CINEMA

CLEAR VOICE

CONNECTIONS  
High-Res Component, HDMI™, RGB, S-Video, AV Inputs

MULTIPLE PROTOCOL INTERFACE (MPI™) SLOT

USB CLONING

ENERGY STAR® COMPLIANT

INVISIBLE SPEAKERS

2-YEAR LIMITED WARRANTY  
(parts/labor)

[www.LGcommercial.com](http://www.LGcommercial.com)



# XD ENGINE

**ULTRA CONTRAST**  
 AT A BLAZINGLY FAST 370 MILLION PIXELS PER SECOND, THE PROCESSOR USES A HISTOGRAM ANALYZATION TOOL TO CLARIFY THE IMAGE DATA ACCORDING TO SIGNAL BRIGHTNESS LEVELS.

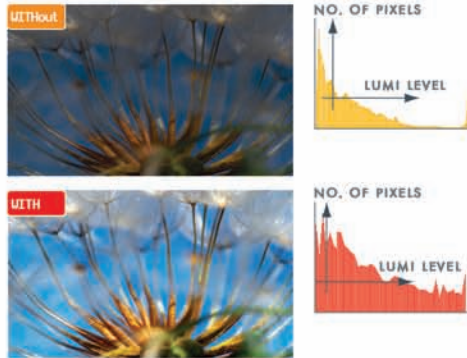

Dramatization

**DYNAMIC BLACK STRETCH**  
 THE MINIMUM BLACK LEVEL OF AN IMAGE IS AUTOMATICALLY DETECTED AND ADJUSTED ACCORDING TO BRIGHTNESS.

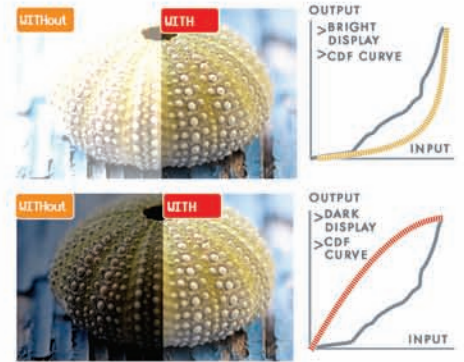

Dramatization

# SPECIAL FEATURES

## Pro:Idiom™

### DIGITAL RIGHTS MANAGEMENT SYSTEM

The Pro:Idiom system's high-quality security unlocks access to premium content availability to help assure rapid, broad deployment of HDTV and other high value digital content. Pro:Idiom™ has been designed specifically for industries that use premium HDTV content from cable, satellite or video on demand (VOD) services and as such, could result in lower costs, and reduced maintenance. This system is one of the leading DRM systems embraced by content providers for both of these key programming sources. By using this embedded approach, security is provided and helps eliminate the possibility of customers tampering with or removing needed components.

## CLEAR VOICE

### BALANCED SOUND TO EMPHASIZE DIALOGUE

Designed to automatically enhance and amplify the sounds of the human voice frequency range, Clear Voice Technology helps keep dialogue audible when background noises swell.



Dramatization



### VIEWING QUALITY AS THE DIRECTOR INTENDED

24p playback matches the original frame rate of film based content, making your home-cinema experience one step closer to a "Real Cinema" experience as the director intended

#### Original Film

Original film has a frame rate of 24 frames per second. To be viewed on standard video equipment such as TVs it must be have a pull down solution.

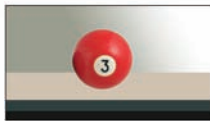

#### NTCS Pulldown Solution

NTSC corrects the frame rate difference by repeating every 4th frame. Sound must be separated from the film to avoid any distortion.



#### Real Cinema

Real Cinema uses a 2:3 pull down which takes ever other frame and splits it into three fields of video for a smoother transition from film to video.

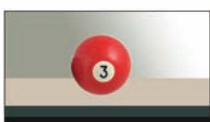

Dramatization

## invisible II. SPEAKER II

### SOUND IS HEARD, NOT SEEN

Breaking through the fixed idea that speaker grills must be exposed, the Invisible Speaker design provides a "fuller sweet spot". Personally tuned by Mr. Mark Levinson, world-renowned audio authority, this unique design has rich and lively sound that can be enjoyed from any angle.



## CLEAR SCREEN

USING THE NOISE FILTER INSIDE THE XD ENGINE<sup>®</sup> CHIP, THE IMAGE IS ANALYZED FOR TEMPORAL AND SPATIAL INFORMATION TO REDUCE MPEG NOISE.

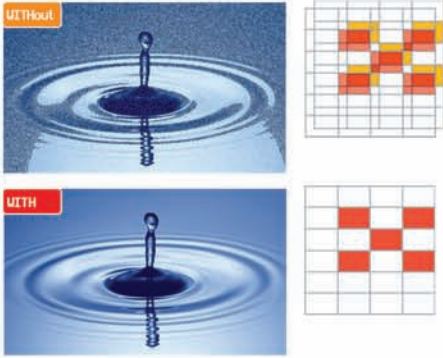

Dramatization

## ADVANCED VIVID COLOR

COLORS THAT ARE SENSITIVE TO THE HUMAN EYE ARE OPTIMIZED TO THE NEAREST TRUE COLOR BY THE SELECTIVE COLOR CONTROL.

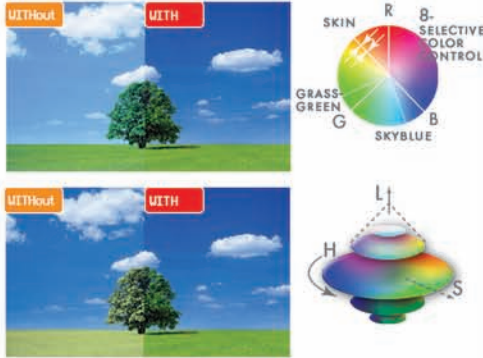

Dramatization

## INTELLIGENT EDGE CONTROL

EDGE LINES ARE EMPHASIZED BY IMPROVING THE TRANSITION FROM THE BACKGROUND TO THE MAIN OBJECT.

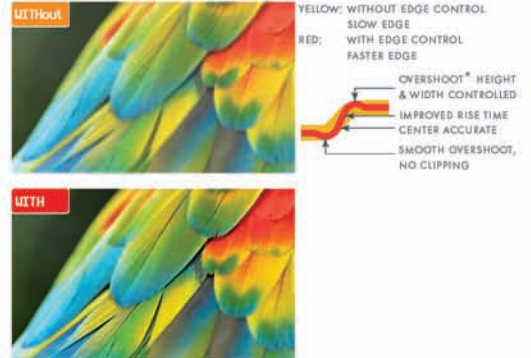

Dramatization

# DIMENSIONS

## CLONING PROGRAMMER REMOTE

**LT2002** (optional)  
QUICKSET II CLONE<sup>®</sup>

The LT2002 allows for custom setup and programming information to be quickly copied from a "master" LG or Zenith brand LCD, Plasma, or CRT TV (with the MPI input) into an unlimited number of identical models. This saves the installers hours of time duplicating the hotel TV settings, such as minimum volume, maximum volume, start up channel, channel mapping, etc.

### 32LG3DC

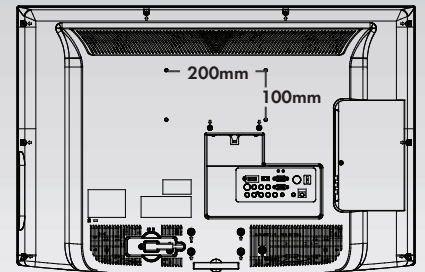
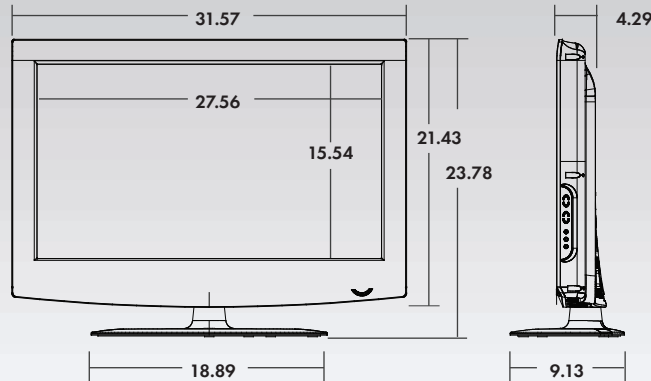

## REAR JACK PANEL

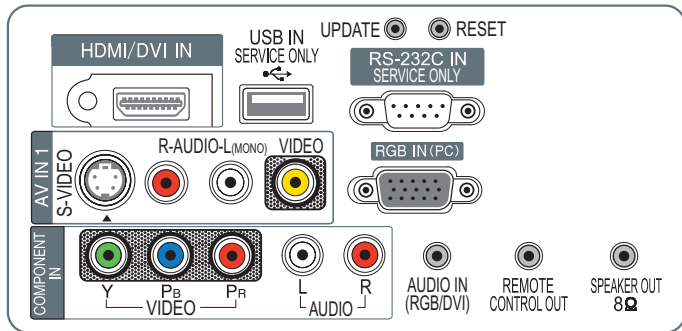

## SIDE JACK PACK PANEL

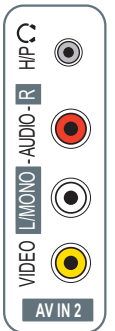

## SPECIFICATIONS

|                            |   |
|----------------------------|---|
| <b>PANEL</b>               |   |
| LCD Panel Type             | 32"   |
| Display Area               | 31.5" diagonal  |
| Aspect Ratio               | 16:9  |
| <b>MAIN SYSTEM</b>         |   |
| MPEG Decoder               | MPEG2/AC-3  |
| Max Output Resolution      | UXGA/WSXGA+   |
| <b>TUNING SYSTEM</b>       |   |
| Number of Tuners           | 1 (ATSC/NTSC)   |
| NTSC                       | Yes (Air Ch2-Ch69, CATV 01Ch~135Ch)                             |
| QAM Clear                  | Yes   |
| <b>MODULE</b>              |   |
| Colors (RGB)               | 8 Bit   |
| Brightness                 | 500 cd/m <sup>2</sup>   |
| Dynamic Contrast Ratio     | 10,000:1  |
| View Angle (H/V)           | 176° / 176° (min.)  |
| <b>VIDEO</b>               |   |
| Display Format             | 1366x768  |
| All Format Converter       | Yes (1080P/1080i/720p/480p/480i @ 768p)                         |
| Comb Filter                | Yes (3D Digital)  |
| Color Temperature Control  | Yes (Cool / Normal / Warm, User)                                |
| DLTI / DCTI                | Yes   |
| Black Stretcher            | Yes   |
| Enhanced Line Doubler      | Yes   |
| Improved Contrast          | Yes   |
| Improved Color             | Yes   |
| Enhanced Noise Reduction   | Yes   |
| Selectable Gamma           | Yes   |
| Real Cinema 3:2/2:2 Mode   | Yes   |
| Aspect Ratio Control       | 6 Modes   |
| Picture Control            | Con/Bri/Tint/Color/Sharpness                                    |
| XD Engine                  | Yes   |
| EZ Picture                 | 7 Modes (Vivid/Standard/Cinema/<br>Sports/Game/Expert1/Expert2) |
| <b>AUDIO</b>               |   |
| Speaker System             | 2 Way 4 Speakers  |
| Dolby Digital Decoder      | Yes   |
| Mono/Stereo/Dual (MTS/SAP) | Yes   |
| Surround System            | SRS TruSurround XT  |
| Total Audio Watts (RMS)    | 2 x 10 W  |
| Bass/Treble/Balance        | Yes   |
| Clear Voice                | Yes   |
| EZ SoundRite (AVL)         | Yes   |
| EZ Sound                   | 5 Modes (Standard, Music, Cinema, Sports, Game)                 |
| <b>JACKS</b>               |   |
| RF In                      | 1 (NTSC+ATSC tuner)   |
| A/V In                     | 1 (Rear), 1 (Side)  |
| S-Video In                 | 1 (Rear)  |
| Component & R/L Audio In   | 1 (Rear)  |
| RGB In (DB15-RGB)          | 1 (Rear)  |
| Audio In (Phone Jack)      | 1 (Rear: PC)  |
| HDMI                       | 1 (Rear)  |
| Speaker Out                | Yes (8ohm mono 1W Phone Jack)                                   |
| Headphone Out              | Yes (Side)  |
| RS-232C                    | 1 (Rear) (Service Only)   |
| IR Out                     | 1 (out to MPI Slot)   |
| USB Cloning                | Yes   |
| RJ-45                      | No  |
| MPI Slot                   | 1 Slot (Standard Type)  |

|                                |                                |
|--------------------------------|--------------------------------|
| <b>SPECIAL FEATURES</b>        |                                |
| Integrated Pro:Idiom           | Yes                            |
| Trilingual Menus               | Yes (English, French, Spanish) |
| Commercial Installation Menu   | Yes (English Only)             |
| Discrete IR                    | Yes                            |
| Auto/Manual Clock              | Yes                            |
| On/Off Timer                   | Yes                            |
| Sleep Timer                    | Yes                            |
| Screen Adjust                  | Yes                            |
| Input Labeling                 | Yes                            |
| EZ Scan (Auto Programming)     | Yes                            |
| Channel Add/Delete             | Yes                            |
| Child Lock                     | Yes                            |
| Channel Labels                 | Yes                            |
| Favorite Channel               | Yes                            |
| Closed Caption/Subtitle        | Analog/Digital                 |
| Mute                           | Yes                            |
| RJP Plug&Play Support          | No                             |
| Flashback (Quick View)         | Yes                            |
| Parental Control with V-Chip   | Yes                            |
| EZ Menus                       | Yes                            |
| <b>REQUIRED APPROVALS</b>      |                                |
| UL, C-UL, NOM                  | Yes                            |
| <b>POWER</b>                   |                                |
| Power Source                   | 110V (220V) 50/60Hz            |
| Power (typ.)                   |                                |
| w/o Dynamic Power Savings      | 190W                           |
| Dynamic Power Savings          | Yes                            |
| Stand-by Consumption           | Under 1W                       |
| Energy Star Compliant          | Yes                            |
| <b>ADDITIONAL INFORMATION</b>  |                                |
| Dimensions w/stand (W×H×D)     | 31.57" x 23.78" x 9.13"        |
| Weight w/stand                 | 29.5 lbs.                      |
| Dimensions w/o stand (W×H×D)   | 31.57" x 21.43" x 4.29"        |
| Weight w/o stand               | 26.2 lbs.                      |
| Packaging Dimensions (W×H×D)   | 38.39" x 26.18" x 7.60"        |
| Shipping Weight                | 35.1 lbs.                      |
| Detachable Stand               | ±90° swivel                    |
| VESA™ Standard Mount Interface | 200mm x 100mm, M4 screw        |
| Power Button                   | Red (Stand-by); Blue (On)      |
| Invisible Speakers             | Yes                            |
| Cable Management Clip          | Yes                            |
| UPC                            | 7 19192 17387 3                |

www.LGcommercial.com



LG Electronics U.S.A., Inc.  
Commercial Products Division  
2000 Millbrook Drive,  
Lincolnshire, IL 60069

Customer Service: 888.865.3026

Contact your LG Regional Sales Representative:  
Hospitality: 800.228.1236  
B2B: 800.897.8788  
Channel Markets: 800.897.8871

32LG3DC\_LGE040803\_PR



All screen images are simulated. Dimensions and weights are approximate. Design, features and specifications subject to change without notice.

© Copyright 2008 LG Electronics USA, Inc. All Rights Reserved. "LG Life's Good" is a registered trademark of LG Corp. XD Engine is a registered trademark of LG Electronics USA, Inc.

VESA is a trademark of Video Electronics Standards Association. Energy Star is a U.S. registered trademark. All other product and brand names are trademarks or registered trademarks of their respective companies.

Printed in the USA. June 2008