

A sunburst graphic with multiple rays emanating from a central point, set against a dark background with a horizontal gradient.

AT10.1 SERIES

Operating and Service Instructions

MICROPROCESSOR-CONTROLLED
FLOAT BATTERY CHARGER

SINGLE PHASE INPUT

GROUP I
(6 - 25 Adc)

HOW TO READ THE AT10.1 MODEL NUMBER

GROUP I RATINGS (6-25 Adc)

Your **AT10.1** model number is coded to describe the options that are included. Please find the model number on the data nameplate and write it in the spaces provided below. Then follow the chart to determine the configuration of your battery charger.

AT10												
A	B	C	D	E	F	K	L	M	N	P	Q	R

DESCRIPTION	CODE	FEATURE
A SERIES	AT10	AT10.1 CHARGER
B NOMINAL DC OUTPUT VOLTAGE	012	12 Vdc
	024	24 Vdc
	048	48 Vdc
	130	130 Vdc
C NOMINAL DC OUTPUT CURRENT	006	6 Adc
	012	12 Adc
	016	16 Adc
	020	20 Adc
D FILTERING	U	UNFILTERED
	F	FILTERED
	E	ELIMINATOR
E AC INPUT VOLTAGE	120	120 Vac 60 Hz ¹
	208	208 Vac 60 Hz ¹
	240	240 Vac 60 Hz ¹
	480	480 Vac 60 Hz ²
	220	220 Vac 50/60 Hz ³
	416	416 Vac 50/60 Hz ³

DESCRIPTION	CODE	FEATURE
F CIRCUIT BREAKER RATING (SEE TABLE)	S	STANDARD
	M	MEDIUM AIC
	H	HIGH AIC
K AUX ALARM RELAY BOARD	AUX	SUPPLIED
	XXX	NOT SUPPLIED
L GROUND PAD	G	SUPPLIED
	X	NOT SUPPLIED
M LIGHTNING ARRESTOR	L	SUPPLIED
	X	NOT SUPPLIED
N FUNGUS PROOFING	F	INCLUDED
	X	NOT INCLUDED
P STATIC PROOFING	S	INCLUDED
	X	NOT INCLUDED
Q NOT USED	X	
R CANADIAN	C	BILINGUAL LABELING

- 1 - 120/208/240 Vac multi-tap input - Unit is wired and shipped from factory at specified voltage.
- 2 - 480 Vac input requires addition of medium or high ampere interrupting capacity circuit breakers.
- 3 - Special order - Please consult factory for availability.

INPUT AND OUTPUT CIRCUIT BREAKER INTERRUPTING RATINGS

CODE	TYPE	AC RATINGS (ALL INPUT VOLTAGES)	DC RATINGS (125 Vdc)
S	STANDARD	240 Vac: 10,000 AIC	10,000 AIC ⁴ 5,000 AIC ⁵
M	MEDIUM AIC	240 Vac: 25,000 AIC 480 Vac: 18,000 AIC	10,000 AIC
H	HIGH AIC	240 Vac: 65,000 AIC 480 Vac: 25,000 AIC	25,000 AIC

- 4 - Rating applies to 130Vdc 16-25 Adc units.
- 5 - Approximate rating applies to all other units.

NOTE:

The model number listed on the charger data nameplate does not include any field-installed options. Also, certain accessories are not included in the model number, even if they are shipped with the charger. Check off below any accessories that were included, or that you install yourself.

- | | |
|--|--|
| <input type="checkbox"/> Enclosure drip shield assembly
<input type="checkbox"/> Floor mounting brackets
<input type="checkbox"/> Rack mounting brackets
<input type="checkbox"/> Cabinet heater assembly | <input type="checkbox"/> NEMA-4/12/13 type enclosure
<input type="checkbox"/> Pad lock for front panel door
<input type="checkbox"/> External temperature compensation probe
<input type="checkbox"/> DNP3 Level 2 / Modbus communications module |
|--|--|

Please find the serial number on the data nameplate and record it here:

IMPORTANT SAFETY INSTRUCTIONS

1. Before using this equipment, read all instructions and cautionary markings on: A) this equipment, B) battery, and C) any other equipment to be used in conjunction with this equipment.
2. This manual contains important safety and operating instructions, and therefore should be filed for easy access.
3. Remove all jewelry, watches, rings, etc. before proceeding with installation or service.
4. Do not touch any uninsulated parts of this equipment, especially the input and output connections, as there is the possibility of electrical shock.
5. During normal operation, batteries may produce explosive gas. Never smoke, use an open flame, or create arcs in the vicinity of this equipment or the battery.
6. Maintain at least 6in / 152mm clearance from all obstructions on the top, bottom and sides of this equipment. Allow sufficient clearance to open the front panel for servicing.
7. Turn this equipment off before connecting or disconnecting the battery to avoid a shock hazard and/or equipment damage.
8. Connect or disconnect the battery only when the battery charger is off to prevent arcing or burning.
9. De-energize all ac and dc inputs to the battery charger before servicing.
10. Do not operate battery charger if it has been damaged in any way. Refer to qualified service personnel.
11. Do not disassemble battery charger. Only qualified service personnel should attempt repairs. Incorrect reassembly may result in explosion, electrical shock, or fire.
12. Do not install the battery charger outdoors, or in wet or damp locations unless specifically ordered for that environment.

**PLEASE READ AND FOLLOW
ALL SAFETY INSTRUCTIONS**

TABLE OF CONTENTS

QUICK OPERATION Back Cover

HOW TO READ THE AT10.1 MODEL NUMBER Inside Front Cover

IMPORTANT SAFETY INSTRUCTIONS i

1 Receiving and Installing the AT10.1 Battery Charger

1.1	Storing the AT10.1	2
1.2	Reporting shipping damage	2
1.3	Unpacking and inspecting the AT10.1	2
	<i>Inspection checklist</i>	2
1.4	Moving the AT10.1	3
	<i>Enclosure type and weight table</i>	3
1.5	Mounting the AT10.1	3
1.5.1	Wall-Mounting the AT10.1	4
1.5.2	Floor-Mounting the AT10.1	6
1.5.3	Rack-Mounting the AT10.1	8
1.6	Changing transformer taps	10
1.7	Making the ac input connections	12
1.8	Making the dc output connections	14
1.9	Wiring the AT10.1 for remote sensing	16
1.10	Wiring to the remote alarm contacts	18
	<i>Auxiliary Relay Board</i> (optional)	19
1.11	Installing the temperature compensation assembly (optional)	20
	<i>Using temperature compensation</i>	22

2 Operating the AT10.1 Battery Charger

2.1	Starting the AT10.1	
2.1.1	Understanding the start-up sequence	24
2.1.2	Checking the installation	24
2.1.3	Starting the AT10.1	24
	<i>Using the digital meter</i>	24
	<i>Factory settings table</i>	25
2.2	Using the AT10.1 front panel features	
2.2.1	If the meter displays an error message	26
2.2.2	Selecting the meter mode	26
2.2.3	Selecting the Float or Equalize mode	27
2.2.4	Choosing the Equalize method	27
	<i>Manual Timer method</i>	27
	<i>Manual Equalize method</i>	28
	<i>Auto-Equalize Timer method</i>	28
2.2.5	Testing the front panel indicators & Summary Alarm Relays	29
2.2.6	Testing the Auxiliary Relay Board	29
2.2.7	Interpreting the alarm indicators	29

TABLE OF CONTENTS

2.3	Setting the AT10.1 parameters	
2.3.1	Understanding parameter settings	30
2.3.2	Setting the Float and Equalize voltages	31
2.3.3	Setting the Equalize timer	32
2.3.4	Setting the Alarms	32
	<i>Setting the high and low dc voltage alarms</i>	33
	<i>Adjusting ground detection sensitivity</i>	34
	<i>Disabling the ground detection alarm</i>	35
2.3.5	Setting the current limit value	35
2.3.6	Enabling the high dc voltage shutdown feature	36
2.3.7	Adjusting the Voltmeter accuracy	37
2.3.8	Using the Low Level Detector (LLD)	38
2.3.9	Using the front panel security feature	39
2.4	Performing routine maintenance	40
	<i>Sample preventive maintenance procedure</i>	42
3	Servicing the AT10.1 Battery Charger	
3.1	A step-by-step troubleshooting procedure	44
3.2	Interpreting front panel error messages	45
3.3	Using the troubleshooting chart	48
3.4	Troubleshooting chart begins on	49
3.5	Replacing defective components	58
3.6	Ordering replacement parts	64
	<i>Replacement parts tables (begin on)</i>	64
	APPENDIX A: AT10.1 Performance Specifications	70
	APPENDIX B: Field Installable Accessories	71
	APPENDIX C: Standard Drawings	
	Standard NEMA-1 Enclosure Outline (Style-586)	72
	Standard NEMA-1 Enclosure Outline (Style-594)	73
	Optional Enclosure Outline Drawings (with penthouse and/or drip shield)	74
	Internal Component Layout Detail w/Common Options	76
	Instrument Panel Detail w/Optional Auxiliary Relay PC Board	78
	Schematic - AT10.1 Group I Battery Charger - Standard w/o Options	80
	Schematic - AT10.1 Group I Battery Charger - with Common Options	82
	Connection Diagram - AT10.1 Group I Battery Charger - Standard w/o Options	84
	Connection Diagram - AT10.1 Group I Battery Charger - with Common Options	86
	APPENDIX D: Recommended Float / Equalize Voltages	88
	APPENDIX E: DNP3 Level 2 / Modbus Communications Module	89
	APPENDIX F: UL Data	89
	CUSTOMER NOTES (manual specifications)	90

TABLE OF CONTENTS

1. RECEIVING THE AT10.1

1.1. STORING THE AT10.1

If you store the AT10.1 for more than a few days before installation, you should store it in its original shipping container, and in a temperature controlled, dry climate. Ambient temperatures of 32 to 122° F / 0 to 50° C are acceptable. Storage should not exceed 2 years due to the limited shelf life of the dc filter capacitors when they are not in service.

1.2. REPORTING SHIPPING DAMAGE

If, on delivery of the AT10.1 or related goods, you discover any damage or shortage, make notation on all copies of delivering carrier's delivery receipt before signing, and notify the delivery person of your findings. If loss or damage is discovered after delivery, notify delivering carrier immediately and request an inspection. The manufacturer does not assume any liability for damage during transportation or handling.

Should the goods require an inspection by or return to the manufacturer, please contact your sales representative for further instructions. Any returned material must be properly packed in compliance with shipping regulations. It is preferable to use the original shipping materials if possible. Mark the outside of the shipping container with the Return Material Authorization (RMA) number issued by the manufacturer.

1.3. UNPACKING AND INSPECTING THE AT10.1

Carefully remove all shipping materials from the AT10.1. Remove the AT10.1 from the shipping pallet for inspection. Save all shipping materials until you are sure that there is no shipping damage.

Once the AT10.1 is unpacked, inspect the unit for possible shipping damage, using the checklist below. If shipping damage has occurred, please refer to section 1.2 on this page for proper reporting.

INSPECTION CHECKLIST

- Enclosure exterior and interior are not marred or dented.
- There is no visible damage to exterior or interior components.
- All internal components are secure.
- Printed circuit boards are firmly seated on their standoffs.
- All hardware is tight.
- All wire terminations are secure.
- The User's Manual is included.
- You received all items on the packing list.

1.4. MOVING THE AT10.1

Once you have established that the AT10.1 is undamaged, identify the enclosure style and weight of your unit. Refer to the table below.

**AT10.1 Enclosure Type And Shipping Weight Table
Group I Cabinet Styles (586 / 594)**

Output Voltage	Ampere Rating				
	6 Adc	126 Adc	16 Adc	20 Adc	25 Adc
12 Vdc	Style- 586 44 lbs 20 kg	Style- 586 44 lbs 20 kg	Style- 586 67 lbs 30 kg	Style- 586 67 lbs 30 kg	Style- 586 67 lbs 30 kg
24 Vdc	Style- 586 44 lbs 20 kg	Style- 586 58 lbs 26 kg	Style- 586 75 lbs 34 kg	Style- 586 75 lbs 34 kg	Style- 586 75 lbs 34 kg
48 Vdc	Style- 586 58 lbs 26 kg	Style- 586 75 lbs 34 kg	Style- 594 110 lbs 50 kg	Style- 594 110 lbs 50 kg	Style- 594 110 lbs 50 kg
130 Vdc	Style- 586 80 lbs 36 kg	Style- 594 147 lbs 67 kg	Style- 594 193 lbs 88 kg	Style- 594 193 lbs 88 kg	Style- 594 193 lbs 88 kg

NOTE: Actual unit is approximately 20 lbs / 9kg below listed shipping weight in table.

The **Style-586 & 594** enclosures do not feature lifting eyes for moving. Instead, whenever possible move the unit with a forklift truck using the supplied shipping pallet. To hoist the unit into a wall-mount or rack-mount location, use a heavy-duty sling applicable to the enclosure size and unit weight. To relocate the **Style-586 & 594** enclosures, use the aforementioned sling on a hoist or forklift truck.

1.5. MOUNTING THE AT10.1

Chose the mounting method for the unit enclosure from the table below.

MANUAL SECTION	MOUNTING METHOD	ENCLOSURE	
		Style-586	Style-594
1.5.1	Wall-Mounting	STANDARD	STANDARD
1.5.2	Floor-Mounting	OPTIONAL	OPTIONAL
1.5.3	19in / 483mm Rack-Mounting	OPTIONAL	OPTIONAL
	23-24in / 584-610mm Rack-Mounting	OPTIONAL	OPTIONAL

INSTALLING THE AT10.1

1.5.1. Wall-Mounting the AT10.1

Wall-mounting the AT10.1 battery charger is the standard way to install the Group I enclosures (Style-586/594). In planning for wall mounting of the AT10.1 consider the following:

1. The wall must be strong enough to properly support the weight of the AT10.1. See the Weight Table located in section 1.4 on page 3. The weight of your AT10.1 may be different from the table value, depending on options or accessories you ordered.
2. Select conduit entrances carefully. Use of the pref-fab knockouts on the sides or bottom of the enclosure will allow removal of the cabinet shroud (and internal access for servicing) without removal of unit from the wall.
3. The location:
 - Should be free of drips and splatter. If dripping liquids are a problem, install a drip shield kit (part number EI0191-00). For kit availability, see ordering information in Appendix B on page 71.
 - Should be between 32 and 122 °F / 0 and 50 °C, with relative humidity between 5 and 95% non-condensing.
 - Must be free of explosive materials.
4. Maintain at least 6in / 152mm of free air on top, bottom and both sides for cooling air.
5. Allow 36in / 914mm front clearance for operation and maintenance.

PROCEDURE

To wall-mount the AT10.1, install four (4) .25in / 6.4mm bolts on the wall rated to support the AT10.1 weight plus a safety factor of at least 2 times. Place the AT10.1 on the bolts, add appropriate mounting hardware and tighten.

Reference the graphics on the next page. For more information, see Outline Drawings in Appendix C on page 72.

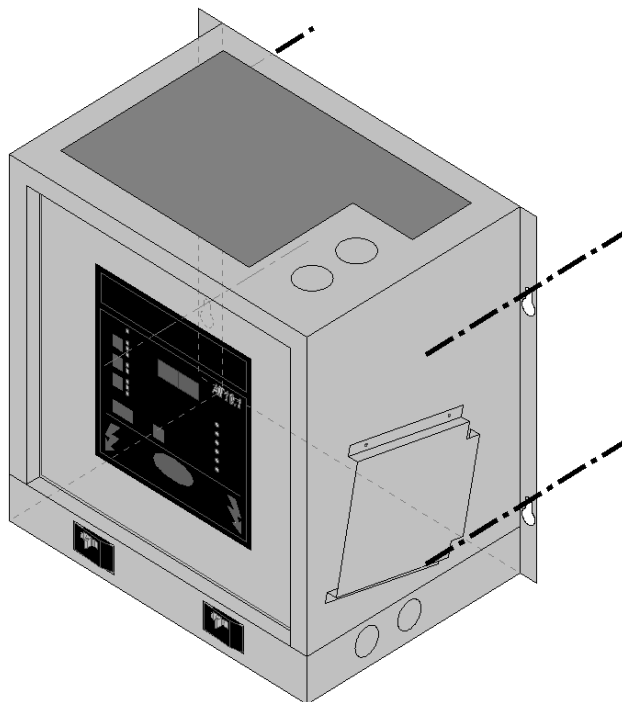

INSTALLING THE AT10.1

WALL-MOUNTING THE AT10.1 - GRAPHICS

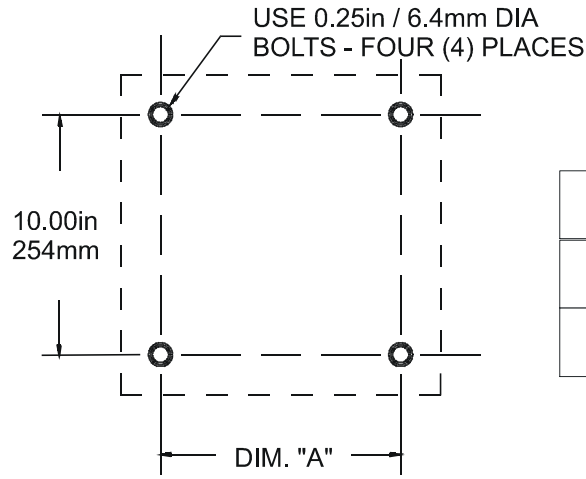

AT10.1 MOUNTING DIMENSION

ENCLOSURE	DIM. "A"
Style-586	15.00in / 381mm
Style-594	18.25in / 464mm

MOUNTING BOLT PATTERN

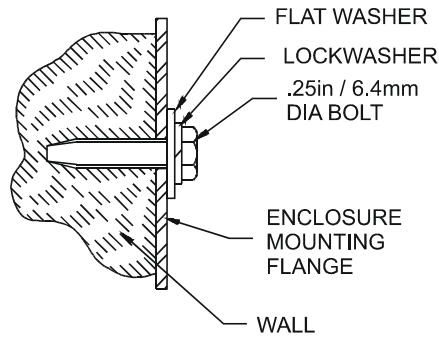

RECOMMENDED MOUNTING HARDWARE LOADING

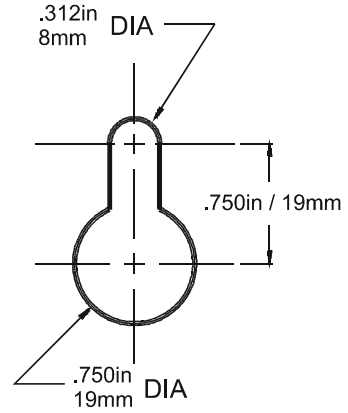

KEYHOLE SLOT USED ON AT10.1 MOUNTING FLANGE

INSTALLING THE AT10.1

1.5.2. Floor-Mounting the AT10.1

To floor mount the AT10.1, you must use the floor mounting accessory kit (part number EI0192-00). For kit availability, see ordering information in Appendix B on page 71. The kit contains brackets that elevate the top of the AT10.1 approximately 47in / 1194mm above floor level, with provision for floor anchoring. The kit includes an instruction sheet (JA0083) showing assembly dimensions and mounting details.

You must locate the anchor-bolt holes at least 4.25in / 108mm from any wall, to allow clearance for the charger enclosure behind the mounting brackets. In addition, you must consider the following:

1. Placement of conduit entrances (use the knockouts on the sides or bottom of the charger to allow access for servicing without removing the unit from the mounting brackets).
2. The location:
 - Should be free of drips and splatter. If dripping liquids are a problem, install a drip shield kit (part number EI0191-00). For kit availability, see ordering information in Appendix B on page 71.
 - Should be between 32 and 122 °F / 0 and 50 °C, with relative humidity between 5 and 95% non-condensing.
 - Must be free of explosive materials.
3. Maintain at least 6in / 152mm of free air on top, bottom and both sides for cooling air.
4. Allow 36in / 914mm front clearance for operation and maintenance.

PROCEDURE

To floor-mount the AT10.1, follow the directions featured in instruction sheet (JA0083), included with your floor-mounting kit (part number EI0192-00). These instructions showing assembly dimensions and mounting details.

Place the AT10.1 assembly on the mounting bolts, add appropriate mounting hardware and tighten.

Reference the graphics on the next page.

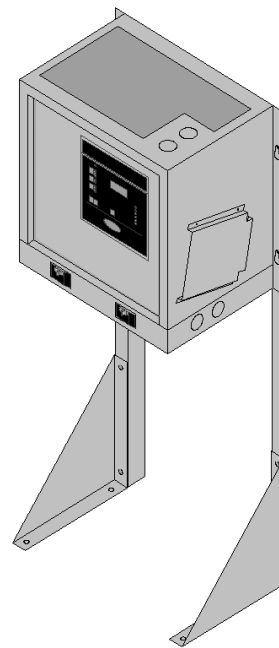

INSTALLING THE AT10.1

FLOOR-MOUNTING THE AT10.1 - GRAPHICS

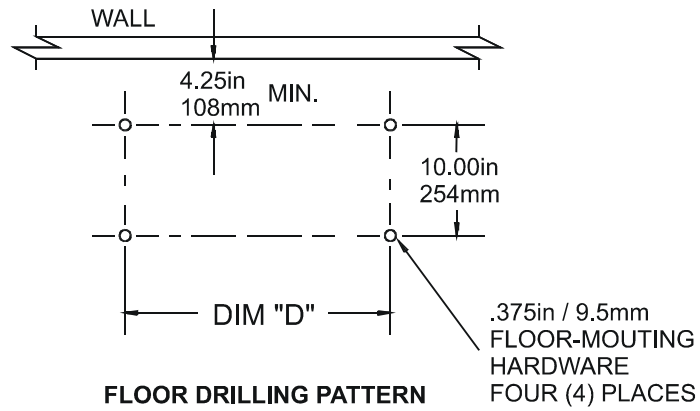
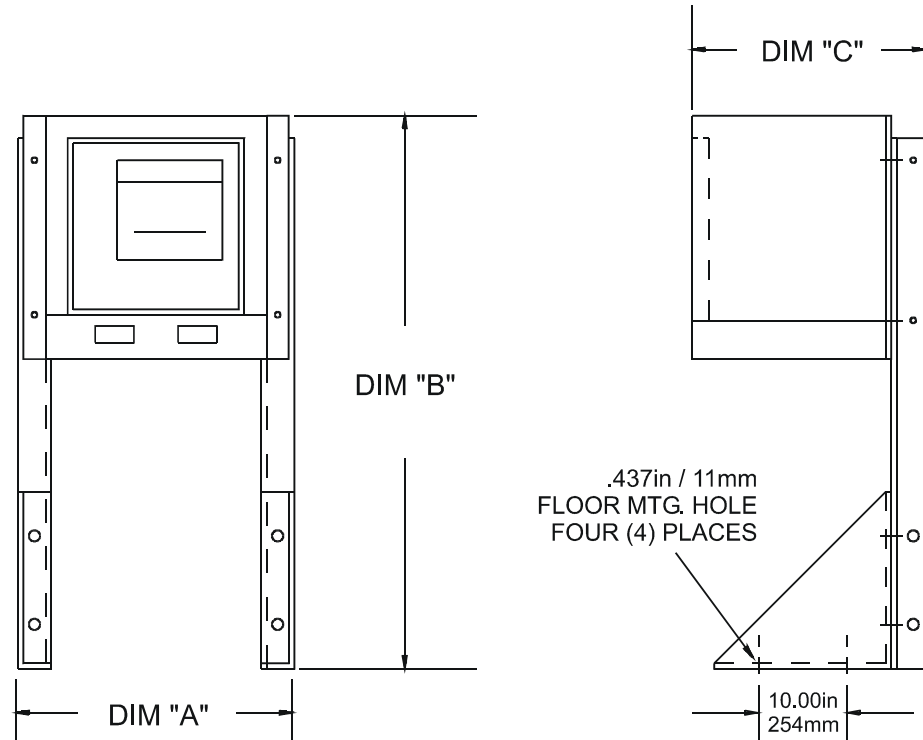

ENCLOSURE	DIMENSION (in / mm)			
	A	B	C	D
Style-586	16.50 / 419	46.63 / 1184	11.75 / 298	15.00 / 381
Style-594	19.75 / 502	47.75 / 1213	14.25 / 361	18.25 / 463

INSTALLING THE AT10.1

1.5.3. Rack-Mounting the AT10.1

The AT10.1 can be installed in most relay racks with standard EIA hole spacing (see the table below for the allowable combinations). The rack mounting kit (part number EI0193-00), includes mounting brackets and the necessary hardware to install one AT10.1 battery charger. The kit includes an instruction sheet (JA0091) showing installation details. For kit availability see ordering information in Appendix B on page 71.

When rack mounting the AT10.1, you must consider the following:

1. The rack must be strong enough to properly support the weight of the AT10.1. See the Weight Table located in section 1.4 on page 3.
2. Placement of conduit entrances (be sure the knockouts on the sides or bottom of the charger are accessible after the charger is rack-mounted).
3. The location:
 - Should be free of drips and splatter. If dripping liquids are a problem, install a drip shield kit (part number EI0191-00). For kit availability, see ordering information in Appendix B on page 71.
 - Should be between 32 and 122 °F / 0 and 50 °C, with relative humidity between 5 and 95% non-condensing.
 - Must be free of explosive materials.
4. Maintain at least 6in / 152mm of free air on top, bottom and both sides for cooling air.
5. Allow 36in / 914mm front clearance for operation and maintenance.

PROCEDURE

To rack mount the AT10.1, first install the brackets onto the rack. Second, mount the AT10.1 onto the rack-mounting brackets using the hardware supplied. Provide at least 6in / 152mm of air space above and below the AT10.1 in the rack for cooling. You do not need to modify the AT10.1 enclosure. Rack-mount outline dimensions are shown on the next page.

CHARGER RATING		RACK WIDTH		
Vdc	Adc	19in / 483mm	23in / 584mm	24in / 610mm
12 Vdc	all	Yes	Yes	Yes
24 Vdc	all	Yes	Yes	Yes
48 Vdc	6-12 Adc	Yes	Yes	Yes
48 Vdc	16-25 Adc	No	Yes	Yes
130 Vdc	6 Adc	Yes	Yes	Yes
130 Vdc	12-25 Adc	No	Yes	Yes

INSTALLING THE AT10.1

RACK-MOUNTING THE AT10.1 - GRAPHICS

Style-586 Enclosure

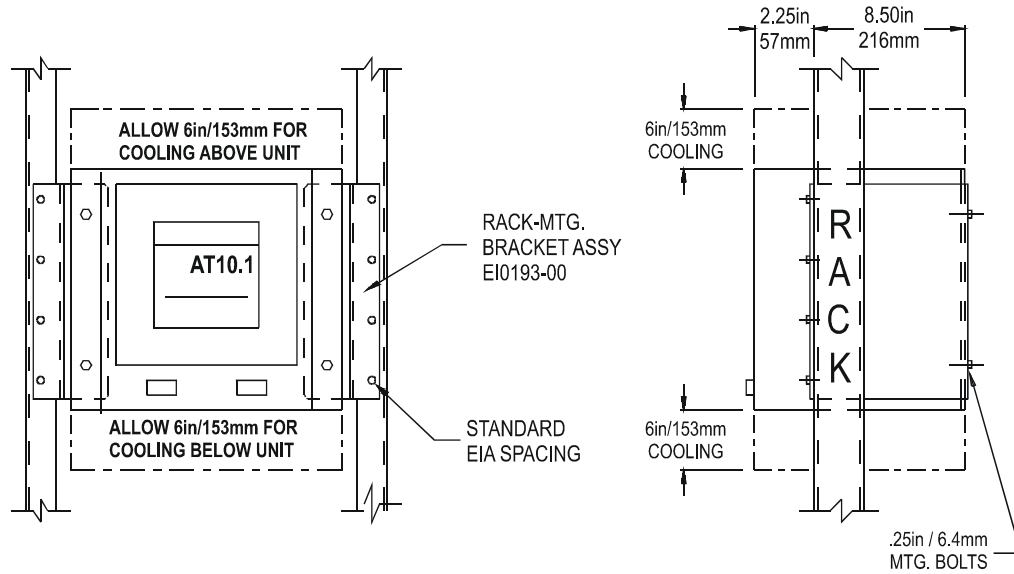

Style-594 Enclosure

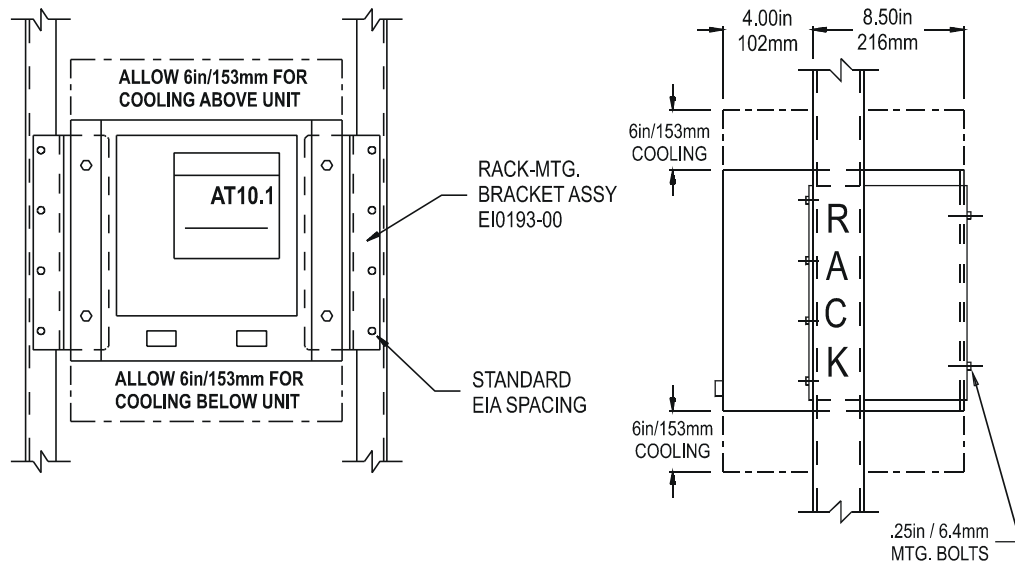

NOTES:

1. Units are installed from the front.
2. Units shown above without penthouse enclosure. If penthouse is used, add 7in / 178mm to top of enclosure.
3. Refer to the outline drawings in Appedix C for enclosure dimensions.

INSTALLING THE AT10.1

1.6. CHANGING TRANSFORMER TAPS

Before you wire ac power to the AT10.1, check the wiring of the main transformer T1, to be sure it is connected for your ac input voltage. The AT10.1 accepts standard input voltages of 120, 208 or 240 Vac by changing jumpers on T1. No other changes are required. *The AT10.1 is wired at the factory for 240 Vac, except on special order.* Models for 220, 380 or 416 Vac at 50/60 Hz are available on special order.

EXCEPTION: An AT10.1 battery charger rated for 480 Vac input uses a special transformer that has no taps or jumpers. The 480 Vac transformer cannot be used for any other input voltage.

Before changing the T1 taps, be sure that ac and dc supplies to the AT10.1 are turned off and locked out. Verify that no voltage is present by using a voltmeter at terminals TB1-L1 and TB1-L2 (ac), TB1(+) and TB1(-) (dc) and remote sense terminals (dc). Note that turning off the ac and dc circuit breakers on the AT10.1 *does not* eliminate live voltages inside the enclosure. Also de-energize any external wiring to the alarm relay contacts.

Verify that all voltages within the enclosure are de-energized and locked out. See section 3.5 for necessary steps to follow when accessing internal components within the AT10.1. Change the jumpers on T1 as shown in the table on the next page. All transformers have (2) jumpers; always use both as specified in the table. The transformers used in the small enclosure (586) use piggyback quick-connect terminals. The transformers in the larger enclosure (594) use 10-32 stud terminals.

Models designed for 220 Vac, 50/60 Hz have no jumpers, and can be used only for that voltage. Models designed for 380 or 416 Vac also have no jumpers, and can be operated on either voltage.

*NOTE: This procedure refers **only** to Group I AT10.1 battery chargers (rated 6-25 Adc). A different procedure exists for Group II AT10.1 battery chargers (rated 30-100 Adc). Please refer to the Operating and Service Instructions specific to the Group II AT10.1 battery charger for changing the transformer taps on these larger units. Otherwise, damage to your charger and equipment may occur.*

INSTALLING THE AT10.1

CHANGING TRANSFORMER TAPS - GRAPHICS

T1 CONNECTION TABLE

INPUT VAC	JUMPERS
120	H1-H3, H2-H5
208	H2-H4 (2) JUMPERS
240	H2-H3 (2) JUMPERS
480	NONE

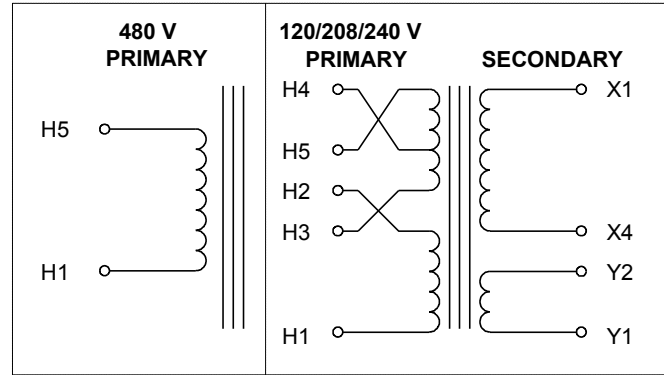

TRANSFORMER SCHEMATIC

PROCEDURE:

- 1) BE SURE ALL VOLTAGES ARE DE-ENERGIZED AND LOCKED OUT.
- 2) BE SURE TERMINALS ARE FULLY SEATED (586 ENCL).
- 3) BE SURE STUD TERMINALS ARE TIGHT (594 ENCL).
- 4) CHECK YOUR WORK AFTER COMPLETION.
- 5) FOR ADDITIONAL INFORMATION, SEE WIRING DIAGRAM IN APPENDIX.

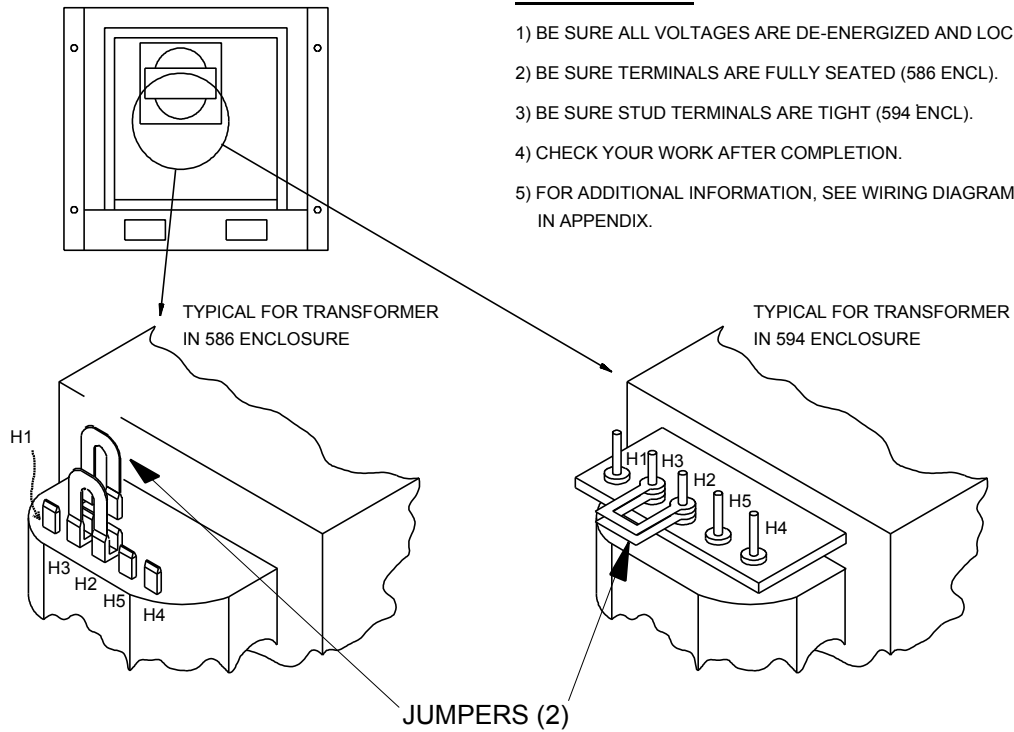

F1-5R2

INSTALLING THE AT10.1

1.7. MAKING THE AC INPUT CONNECTIONS

Follow these steps to connect ac power to the AT10.1:

1. Use a branch circuit breaker or fused disconnect switch, properly sized for the maximum input current of the AT10.1, as shown in the table below. This device should have lockout capability so that the ac input can be de-energized and locked out for maintenance. A time delay circuit breaker or slow-blow fuse is recommended.
2. Size the ac input wiring per the National Electric Code (NEC) and local codes for the rating of the branch circuit breaker or fused disconnect switch.
3. All specific requirements of your facility take precedence over these instructions.
4. Be sure the AT10.1 main transformer, T1, is properly connected for your ac input voltage. See section 1.6 for details.
5. Remove the safety cover.
6. Run the ac wiring to terminals TB1-L1, TB1-L2 and TB1-GND on the I/O panel in the enclosure. Compression lugs accepting wire sizes #14-6 AWG. wire are supplied for your convenience. To make these connections, strip the insulation .50in / 13mm on the incoming wires and connect the wires to the appropriate lugs as shown on the next page.
7. Using a flat-head screwdriver, securely tighten the compression screws on the lugs to 35-45 in-lb / 4.0-5.1 Nm.
8. Reinstall the safety cover after you have made and checked all connections.

MAXIMUM INPUT CURRENT AT 120 Vac¹

OUTPUT CURRENT	OUTPUT VOLTAGE			
	12	24	48	130
6	2	4	8	14
12	3	7	14	30
16	4	9	18	32
20	5	11	23	39
25	6	14	29	49

Example (shaded):

A 130 Vdc/12 Adc battery charger draws **30 Aac** at 120 Vac.

All currents shown are ±10%.

¹ To determine the input current, I_{ac} , for other input voltages, use the formula:

$$I_{ac} = I_T \times \frac{120}{V_{ac}}$$

where V_{ac} is the new input voltage, and I_T is the input current from the table above.

INSTALLING THE AT10.1

MAKING THE AC INPUT CONNECTIONS - GRAPHICS

REPLACE SAFETY COVER
AFTER CONNECTIONS ARE MADE

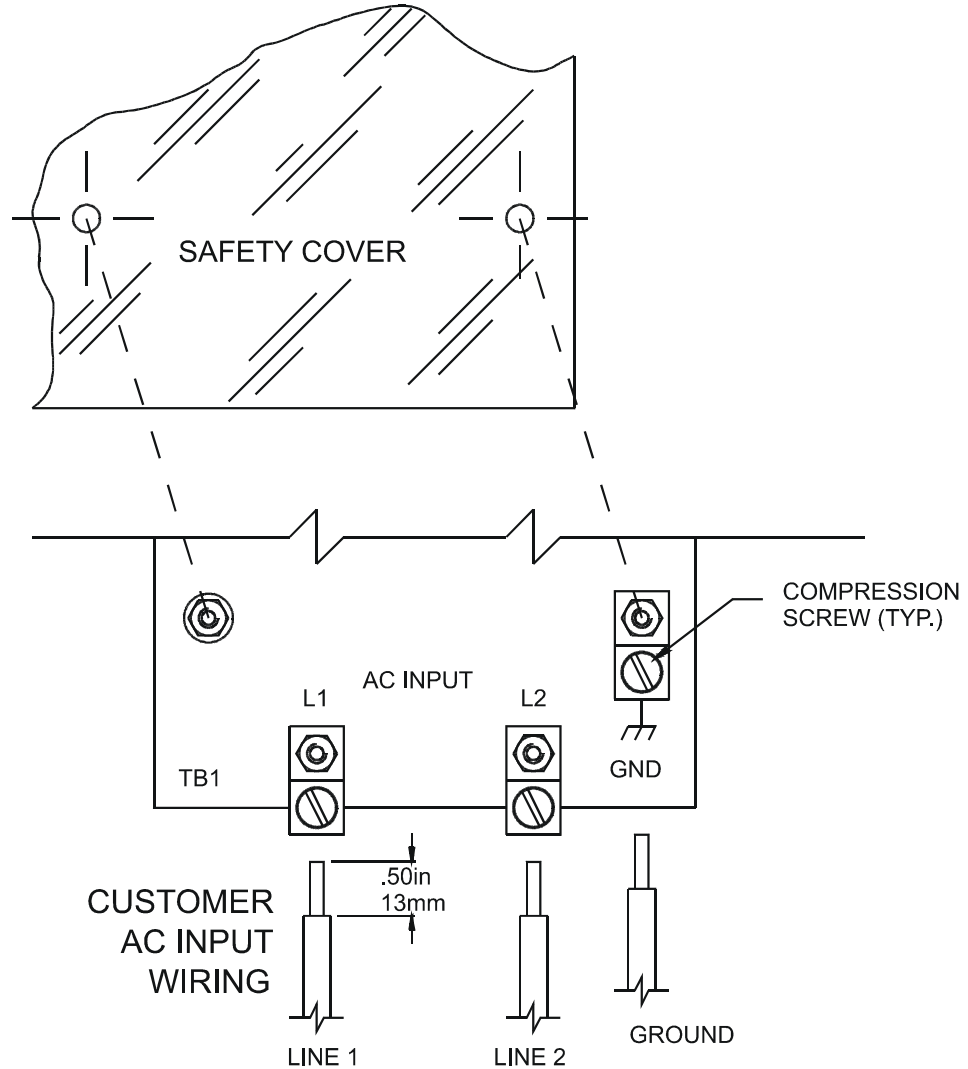

NOTES:

1. The drawing above does not show other components mounted to the I/O panel. Be careful not to disconnect any other component leads.
2. Always use a proper ground.
3. On 120 Vac input, connect the neutral leg to the terminal L2.
4. Wire insulation must be rated for 194° F / 90° C or better.
5. Use copper or aluminum conductors only.

INSTALLING THE AT10.1

1.8. MAKING THE DC OUTPUT CONNECTIONS

Follow these steps to connect the battery to the AT10.1:

1. Size the dc wiring to minimize voltage drop. The acceptable wire size depends on your installation. As a guideline, the voltage drop should not exceed 1% of nominal output voltage at full current. Refer to the table below to determine the voltage drops for various wire sizes, currents and distances.

WIRE SIZING CHART

VOLTAGE DROP PER 100ft / 30.5m OF WIRE (FOR COPPER AT 68° F / 20° C)

WIRE SIZE (AWG.)	DC CURRENT (AMPERES)				
	6	12	16	20	25
16	2.5V	5.0V	6.7V	8.2V	10.5V
14	1.6V	3.2V	4.2V	5.3V	6.6V
12	1.0V	2.0V	2.6V	3.3V	4.2V
10	0.63V	1.3V	1.7V	2.1V	2.6V
8	0.40V	0.80V	1.1V	1.3V	1.7V
6	0.25V	0.50V	0.66V	0.83V	1.1V
4	0.16V	0.32V	0.42V	0.52V	0.65V

EXAMPLE: 100ft / 30.5m of #8 AWG. wire at 16A has a 1.1V drop.

2. All specific requirements of your facility take precedence over these instructions.
3. The AT10.1 is factory wired to regulate output voltage at the output terminals. If the total voltage drop is greater than 1% (e.g., 1.3V for a 130 Vdc system), remote sense wiring is recommended, see section 1.9.

PROCEDURE

1. Use a dc disconnect switch or circuit breaker between the AT10.1 and dc bus. This device should have lockout capability to allow the AT10.1 to be disconnected from the dc bus for maintenance.
2. Remove the safety cover.
3. Run the dc wiring to terminals TB1(+) and TB1(-) on the I/O panel in the enclosure. Compression lugs, accepting wire sizes #14-6 AWG., are supplied for your convenience. To make these connections, strip the insulation .50in / 12.7mm on the incoming wires. Connect the wires to the appropriate lugs as shown on the next page.
4. Using a flat-head screwdriver, securely tighten the compression screws on the lugs to 35-45 in-lb / 4.0-5.1 Nm.
5. Reinstall the safety cover after you have made and checked all connections.

MAKING THE DC OUTPUT CONNECTIONS - GRAPHICS

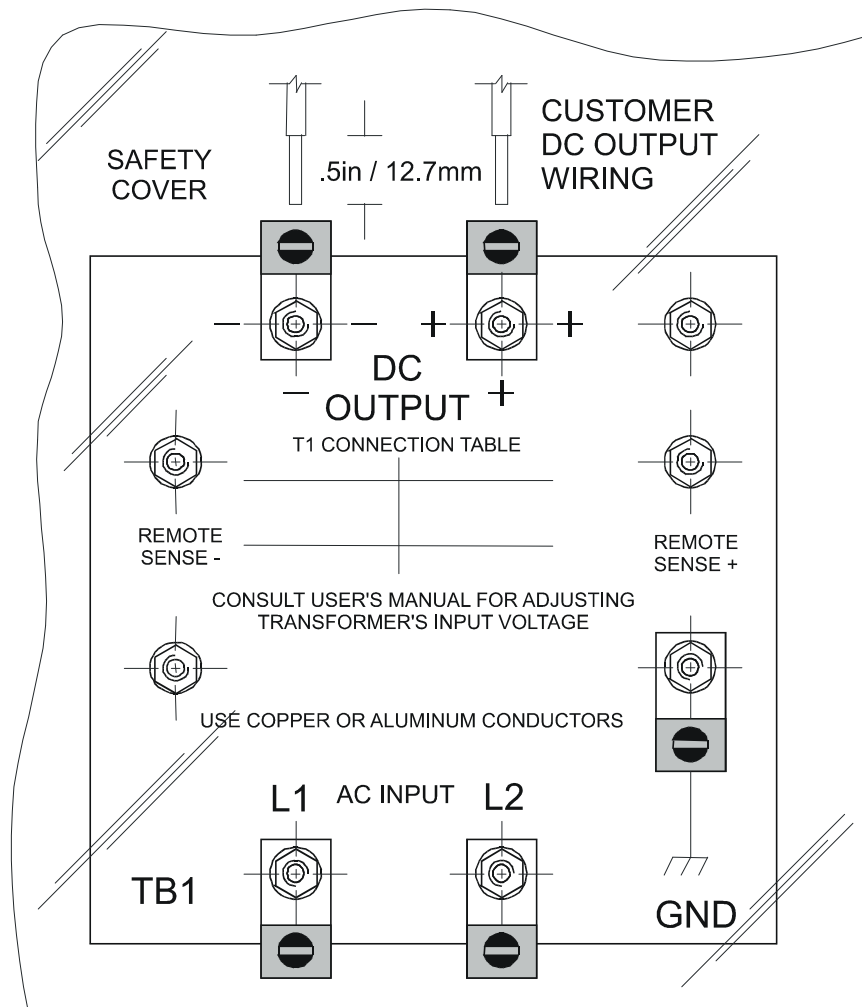

NOTES:

1. The drawing above does not show other components mounted to the I/O panel. Be careful not to disconnect any other component leads.
2. Always use a proper ground.
3. Wire insulation must be rated for 194° F / 90° C or better.
4. Use copper or aluminum conductors only.

INSTALLING THE AT10.1

1.9. WIRING THE AT10.1 FOR REMOTE SENSING

You can wire the AT10.1 to regulate the output voltage at the battery terminals, instead of at the charger output terminals. Remote sensing does the following:

1. Compensates for voltage drop in the dc wiring between the AT10.1 and the battery.
2. Directly monitors the battery or dc bus voltage. The front panel meter displays the actual voltage on the dc bus.

You wire the AT10.1 for remote sensing by installing a two-wire cable from the AT10.1 remote sense terminals to the battery terminals. The AT10.1 control circuitry then measures the dc voltage at the battery terminals, and controls the output of the charger to maintain the battery voltage at the desired float or equalize voltage.

*NOTE: If the remote sense wiring fails, the AT10.1 detects the fault, and displays **E 06** on the front panel meter. See section 3.2 for details.*

CAUTION: The AT10.1 cannot protect against short circuits in the remote sense wiring. You should install a 1.0A fuse at the battery or dc bus end of the remote sense cable.

To wire the AT10.1 for remote sensing, follow the procedure and diagram on the next page.

If you ever need to disable remote sense, follow the steps below:

- De-energize and lock out all ac and dc voltages to the AT10.1. Check with a voltmeter.
- Disconnect the remote sense wires from the battery or dc bus terminals first.

CAUTION: You must do the steps above first.

- Remove the remote sense leads from the remote sense (+) and (-) terminals on the I/O panel. Insulate each lead separately. Coil up the wires and leave them in the bottom of the charger, in case you want to wire for remote sense again in the future.
- Reconnect wire # **74** to the dc output (+) terminal.
- Reconnect wire # **72** to the dc output (-) terminal.
- Restart the AT10.1 according to the instructions in section 2.1.

INSTALLING THE AT10.1

PROCEDURE

1. De-energize and lock out all ac and dc voltages within the AT10.1 enclosure. Check with a voltmeter.
2. Remove safety shield.
3. Wire the AT10.1 remote sense to the dc bus as shown in the figure below.

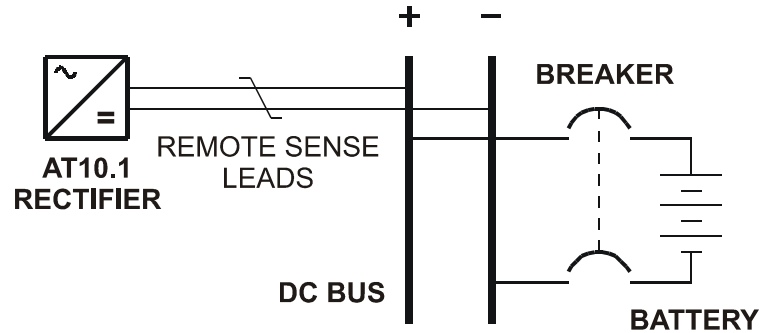

4. Move wires # 72 and # 74 from the TB1 (-) and (+) dc output terminals to the corresponding remote sense terminals as shown in the lower left figure.
5. Connect the external remote sense leads from the battery or dc bus to the remote sense terminals on the I/O panel as shown in the lower right figure.

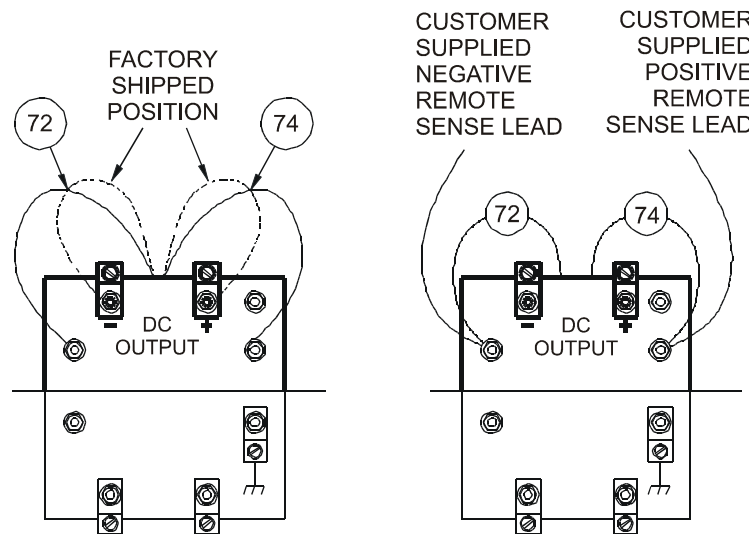

6. Check your work thoroughly. Replace the safety shield before reenergizing the charger.
7. Restart the AT10.1 according to the instructions in section 2.1.

NOTES:

1. Use #16 AWG. twisted pair.
2. Maximum current is 150 mA.
3. Run leads in their own conduit.
4. Fuse the wiring at the battery or dc bus.

INSTALLING THE AT10.1

1.10. WIRING TO THE REMOTE ALARM CONTACTS

Built-in common alarm relay

The Primary Alarm functions are included as standard equipment with the AT10.1. The Common Alarm relay, located on the main control circuit board on the back of the door, provides one form C summary alarm (common alarm) contact that transfers for any alarm. Follow the procedure below to wire a remote annunciator to this contact. See section 2.2.7 for a description of the alarm functions.

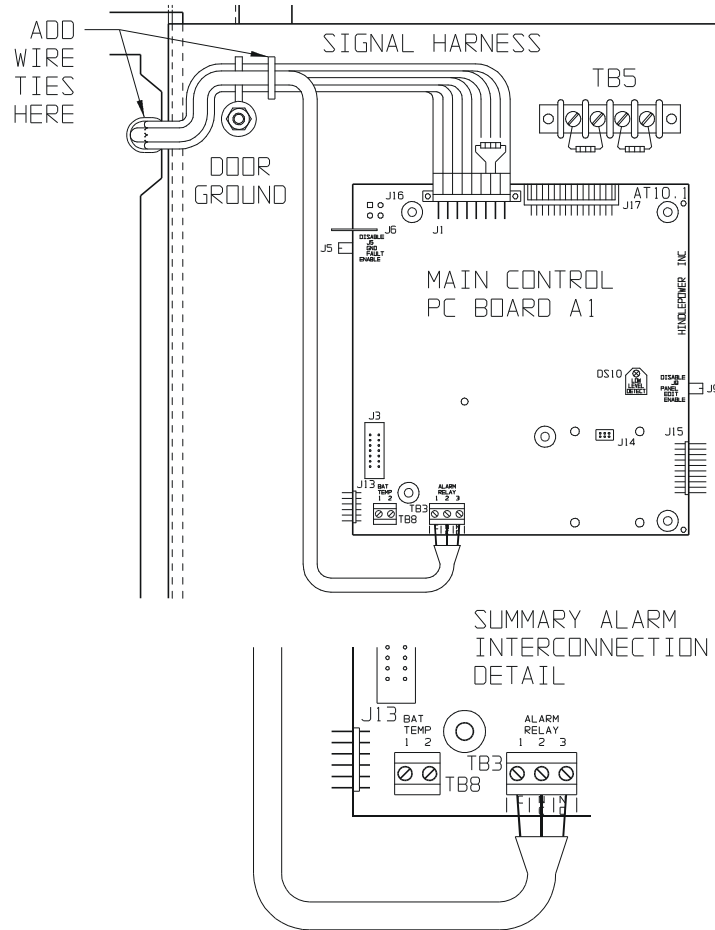

PROCEDURE

1. Allow 30in / 762mm of wire inside the enclosure (excess will be trimmed).
2. Route wires to front door by following the existing harness through the door hinge as shown. Use (2) wire ties and allow a 4-6in / 102-153mm loop for the hinge.
3. Trim wires to the proper length for connecting to TB3. Strip .25in / 6.4mm of insulation from the wires. Make the connections at TB3, and securely tighten the screws.

NOTES:

1. Alarm contacts are rated at 0.5A / 125 Vac or Vdc.
2. Terminal block is a compression type, accepting wire sizes #22-14 AWG.
3. Terminals are labeled in non-alarm condition.

Auxiliary Relay Board (optional)

The Auxiliary Alarm Relay PC Board (A5), mounted inside the separate top enclosure (penthouse), provides two form C contacts (TB4-1 through TB4-36) for each of the following individual alarms:

- High DC Voltage
- Low DC Voltage
- DC Output Failure
- AC Failure
- Ground Fault Detection (positive or negative)
- Summary Alarm

HVDC			LVDC			DC OUT FAILURE			AC FAIL			GROUND DETECT			SUMMARY																				
C, NC, NO	C, NC, NO	C, NC, NO	C, NC, NO	C, NC, NO	C, NC, NO	C, NC, NO	C, NC, NO	C, NC, NO	C, NC, NO	C, NC, NO	C, NC, NO	C, NC, NO	C, NC, NO	C, NC, NO	C, NC, NO	C, NC, NO																			
1	2	3	4	5	6	7	8	9	10	11	12	13	14	15	16	17	18	19	20	21	22	23	24	25	26	27	28	29	30	31	32	33	34	35	36

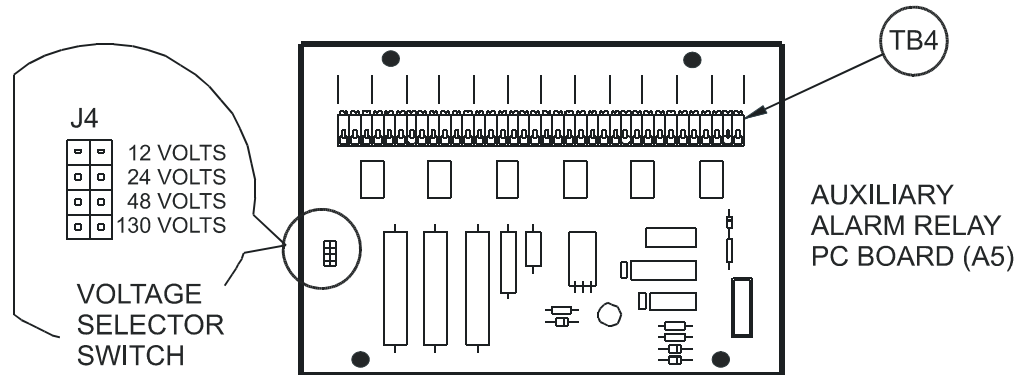

Follow the procedure below to wire annunciators to one or more of these alarm contacts.

PROCEDURE

1. Remove the top panel from the penthouse enclosure (on top of the main charger enclosure).
2. Route your remote annunciator wiring into the penthouse enclosure through one of the unused knockouts in the side of the enclosure.
3. Connect the wiring (use #22-14 AWG.) to the appropriate terminals of TB4 on the back wall of the penthouse enclosure (as shown in the drawing at the right). Strip each wire .25in / 6.4mm, and securely tighten the terminal screws. The terminals are labeled in the non-alarm condition.
4. Replace the top panel on the penthouse enclosure.

NOTES:

1. Alarm contacts are rated at 0.5A / 125 Vac or Vdc.
2. Terminal block is a compression type, accepting wire sizes #22-14 AWG.
3. Terminals are labeled in non-alarm condition.

INSTALLING THE AT10.1

1.11. INSTALLING TEMP. COMPENSATION ASSEMBLY (OPTIONAL)

The temperature compensation assembly consists of a probe containing a temperature-dependent resistor in an epoxy module that you install near your battery. There are three steps in installing the assembly:

1. Mounting the probe assembly near the battery.
2. Installing an interconnection cable from the probe assembly to the AT10.1.
3. Wiring the charger end of the cable to a terminal block on the main control circuit board.

The actual tempco probe is the same for all battery types and all output voltages of the AT10.1. The kit part numbers differ depending on cable length ordered. See the tables in Appendix B on page 71 for ordering information. Each kit contains detailed installation instructions (JA5015-00). The main elements of the installation are outlined below.

WARNING:

High voltages appear at several points inside the battery charger. Use extreme caution when working inside the charger. Do not attempt to work inside the charger unless you are a qualified technician or electrician.

Disconnect and lock out all power to the battery charger before starting to remove or replace any components. Turn the ac power off at the distribution panel upstream from the battery charger. Disconnect the battery from the charger output terminals.

1. De-energize and lock out all ac and dc voltage sources to the AT10.1. Check with a voltmeter before proceeding.
2. Mount the probe on a clean, dry surface as close to the battery as possible, such as the battery rack. **Do not** mount the probe:
 - on the battery itself
 - on unpainted wood or bare galvanized metal.
 - on plastic surfaces
3. To apply the probe, clean the mounting surface with isopropyl alcohol, and allow to dry thoroughly. Remove the protective backing from the double-faced adhesive tape on the probe, and securely press it onto the surface.
4. Install the cable supplied with the temperature compensation probe kit:
 - Start at the AT10.1. The end of the cable with two stripped wires and one lead with a quick-connect terminal will be connected inside the enclosure. Leave 30in / 762mm of cable inside the enclosure, and route the other end to the probe at the battery.

INSTALLING THE AT10.1

- Run the cable through a conduit if possible, but not through a conduit containing any power wiring.
- Route the other end to the probe at the battery and coil up excess cable.

NOTE: If the standard (25ft / 7.6m) cable isn't long enough, longer cable assemblies are available in lengths of 50, 100 & 200ft / 15.2, 30.5 & 61.0m. See Appendix B on page 71 for ordering information.

- Be sure your wiring conforms to the NEC and your facility requirements.
5. Attach the interconnection cable to the AT10.1 as shown in the figure below:

- Route the cable within the AT10.1 enclosure so that it runs with the wire harness to the back of the front panel, and easily reaches the main control circuit board.
- At the main control circuit board, insert one of the bare wires from the cable into each terminal of TB8. Polarity is not important.

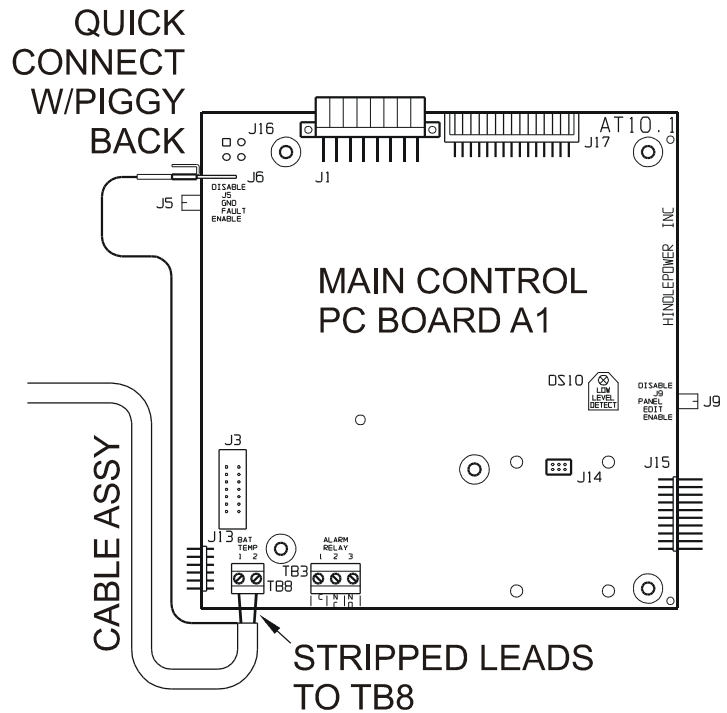

- Unplug the harness ground wire # 30 from terminal J6 on the left edge of the main control circuit board. Plug the connector at the end of the nylon-shielded wire of the cable assembly onto J6. Reconnect the ground wire # 30 from the system harness onto the piggy-back connector featured at the end of the nylon-shielded wire.
 - Using plastic wire ties, tie the interconnection cable loosely to the existing wire harness. Be especially sure that the cable conforms to the service loop at the hinge end of the door.
6. At the battery, connect the quick-connect terminals to the temperature compensation probe. Polarity is not important. Coil up any excess wire and tape or tie it together to prevent damage.

INSTALLING THE AT10.1

7. Check your work. Be sure that:
 - All connections are secure.
 - The shield is connected to ground *at the charger end only* (on the main circuit board).
 - The cable is connected to TB8 on the circuit board. Other terminal blocks may look similar.
8. Restart the AT10.1 using the startup procedure in section 2.1. During startup, the AT10.1 displays **LEAD** on the front panel, indicating that the temperature compensation is set up for lead-acid batteries. While this is being displayed, you can press any front panel key to change the display to read **NICD**, to change the temperature compensation setup for nickel cadmium batteries. The choice you make is saved internally, and will be used again by the AT10.1 the next time it starts.
9. Adjust the output float and equalize voltages to the battery manufacturer's recommended values, using the AT10.1's front panel meter, as described in section 2.3.2.

*NOTE: If the temperature compensation probe, or the wiring from the probe to the AT10.1, is damaged and becomes an open circuit, the AT10.1 detects the damage and displays **E 08** on the display. The charger then reverts to normal non-temperature-compensated operation until the probe or wiring is repaired. Once the probe is repaired, you must restart the AT10.1 to activate the probe, as described in section 2.1.*

Using temperature compensation

Whenever an electric storage battery is being charged, the terminal voltage of the battery changes a small amount whenever the battery temperature changes. As the battery temperature increases, its terminal voltage decreases. When the battery is being charged with a float type charger, with a constant output voltage, the float current increases when the temperature increases. This results in overcharging the battery, which can result in damage to the materials, or at least the need for more frequent maintenance.

When the AT10.1 is equipped with a temperature compensation probe, it is able to adjust the output voltage applied to the battery to keep the float current constant, thereby avoiding overcharging. The probe senses the ambient temperature at the battery, and adjusts the output float/equalize voltages to compensate for variations in temperature. If the ambient temperature increases, the AT10.1 output voltage decreases.

INSTALLING THE AT10.1

Please note the following:

- You should set the Float and Equalize voltages to the values recommended by your battery manufacturer for 77° F (25° C).
- When you enter the Edit mode to adjust the Float or Equalize voltage (see section 2.3.2), the front panel meter shows the 77° F (25° C) value for the Float or Equalize voltage, even if the battery is warmer or cooler than 77° F (25° C).
- The actual output voltage of the AT10.1 may be different from the value shown on the front panel meter, if the battery is warmer or cooler than 77° F (25° C).
- Use a digital meter to measure the actual output voltage of the AT10.1. If you know the temperature at the temperature compensation probe, you can use the graph below to determine that the output voltage is correct.
- If the battery temperature goes below 32° F (0° C), there will be no further increase in charger output voltage. Likewise, if the battery temperature goes above 122° F (50° C), there is no further decrease in output voltage.

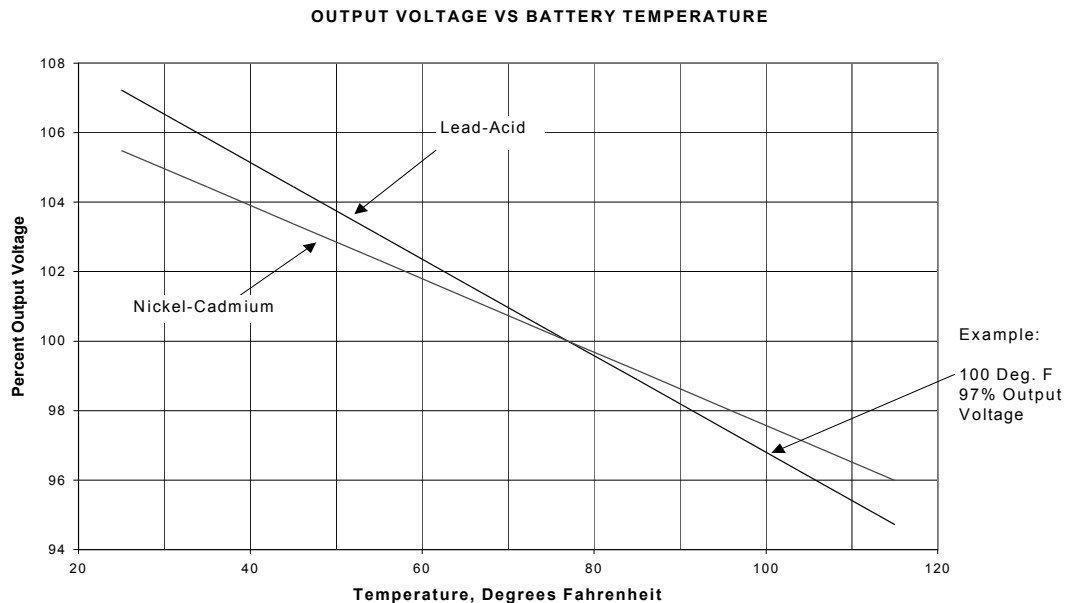

EXAMPLE: Suppose you have a lead-acid battery whose temperature is 100° F / 37.8° C. As shown on the graph, the output voltage should be approximately 97% of the 77° F voltage. If the float voltage is set on the front panel to 132 Vdc, the actual output voltage will be:

$$132 \times 0.97 = 128 \text{ Vdc}$$

OPERATING THE AT10.1

2. OPERATING THE AT10.1 BATTERY CHARGER

2.1. STARTING THE AT10.1

2.1.1. Understanding the startup sequence

The AT10.1 is set up at the factory to work with most common batteries and loads without further adjustment. When you start the AT10.1 for the first time, the factory settings (float voltage, equalize voltage, etc.) control the operation of the charger. You can change the settings after you start the charger. The **FACTORY SETTINGS** are shown in table on page 25.

The AT10.1 startup routine takes about five seconds. The microprocessor that controls the AT10.1 initializes the charger by reading the settings that are stored internally. The control circuit then "soft starts" the charger, and the dc output voltage and current increase gradually to the rated value.

2.1.2. Checking the installation

Be sure that you have followed the installation instructions carefully. Check the ac input supply voltage and the battery voltage, and be sure that they match the information on the AT10.1 nameplate. *Verify that the jumpers on the main transformer T1 are correct for your ac supply voltage.* Open the front panel, and check the battery polarity at the TB1 (+) and (-) terminals.

2.1.3. Starting the AT10.1

When you are sure that all connections to the AT10.1 are properly made, follow these steps to start up the AT10.1:

- Turn on the front panel dc circuit breaker. The digital meter indicates the battery voltage only. If the meter display doesn't light, *do not proceed*. Turn off the dc breaker, and check all connections and the battery polarity again. Also check the battery voltage. It must be above 50% of nominal voltage to turn on the display. If you can't find the problem, refer to the *Troubleshooting Procedure* in section 3.1 on page 44.

Using the Digital Meter

When you first start the AT10.1, the meter display alternates between dc output voltage and dc output current. Each reading is held for two seconds; lights to the left of the display indicate whether the meter is displaying voltage or current.

If you want to "freeze" the meter to display only voltage, press the **METER MODE** key on the front panel. To freeze the meter to display only current, press the key again. Press the key twice more to revert to the alternating display.

CAUTION: *If you try to turn on the dc circuit breaker with the battery connected in reverse polarity, the circuit breaker will immediately trip. Do not try to close the dc breaker again, since this may damage the battery charger. Correct the battery polarity before proceeding.*

OPERATING THE AT10.1

- If you have an optional temperature compensation probe installed, the front panel displays **LEAD** during startup, indicating that the temperature compensation is set up for lead-acid batteries. While this is being displayed, you can press any front panel key to change the display to read **NICD**, to change the temperature compensation setup for nickel cadmium batteries. The choice you make is saved internally, and will be used again by the AT10.1 then next time it starts.
- Turn on the front panel ac circuit breaker. The digital meter displays the output voltage and current. See *Using the Digital Meter* on page 24. You should hear a soft hum from the AT10.1 as the output current increases.

NOTE: If you turn on the ac breaker before the dc breaker, and you have a filtered model of the AT10.1, there is a possibility that the dc breaker will trip when you try to turn it on. This is caused by the filter capacitors discharging into the battery. To get around this problem, turn off the ac breaker. Restart the AT10.1 by turning on the dc breaker first.

- The green **FLOAT** indicator lights. Press the **CHRG MODE** key on the front panel. The **FLOAT** indicator goes off, and the yellow **EQLZ** indicator lights. Press the **CHRG MODE** key again to return the charger to the float mode.

The table below shows the normal factory settings for float and equalize voltages, equalize time, current limit setting, and alarm settings. If your purchase order specified other float or equalize voltage settings, a tag attached to the front panel of the AT10.1 lists the actual voltage settings.

FACTORY SETTINGS FOR ALL PARAMETERS

Parameter	Nominal Vdc			
	12	24	48	130
Float Voltage	13	26	52	131
Equalize Voltage	14	28	56	139
HVDC Alarm	14.4	28.8	57.6	144
LVDC Alarm	12	24	48	120
Equalize Time	24 Hours			
Equalize Method	Manual Timer			
Current Limit	110% of nominal output current			
HVDC Shutdown	Disabled			

OPERATING THE AT10.1

2.2. USING THE AT10.1 FRONT PANEL FEATURES

2.2.1. If the meter displays an error message

When you apply power to the AT10.1 for the first time, the micro-processor control circuit performs a diagnostic check of the system. If it finds anything wrong, it writes an error code to the display, such as **E 01**. Below is a list of the error codes. See section 3.2 for a full explanation of each error code.

Error Code	Explanation
E 01	Resistor R2 is open or defective.
E 02	Short circuit on output
E 03	HVDC Shutdown has occurred
E 04	Internal memory failure
E 05	Not used
E 06	Failure in Remote Sense wiring
E 07	DC breaker is open, or internal or external output wiring is defective.
E 08	Defective temperature compensation probe
E 09	Misadjusted current limit
E 10	Open internal feedback loop
A 02	Equalize mode is inhibited

2.2.2. Selecting the meter mode

- Press the **METER MODE** key to change the meter display mode. The digital meter has four operating modes:
 1. Alternating between output voltage and output current. When the charger is in a timed equalize mode, the meter alternates between output voltage, output current, and equalize hours remaining.
 2. Displaying output voltage only. The **DC Volts** indicator lights.
 3. Displaying output current only. The **DC Amps** indicator lights.
 4. Displaying equalize hours remaining only. The **EQLZ HRS REMAINING** indicator lights. If the AT10.1 is not in a timed equalize mode, the meter displays the full programmed equalize time.
- When the charger starts initially, the meter alternates, showing output voltage and output current. The **DC Volts** and **DC Amps** indicators light alternately to indicate what is being displayed.

2.2.3. Selecting the Float or Equalize mode

The AT10.1 has 2 output voltage settings, Float and Equalize. Use the Float mode for all normal battery charging and to operate your dc system. Use the Equalize mode if it is necessary to balance the level of charge among the cells of the battery. Consult your battery data sheets for information on equalize-charging your battery.

- Press the **CHRG MODE** key to change to the equalize mode.

If the equalize method is set to manual timer or auto-equalize timer, the charger will revert to the float mode at the end of the selected equalize time.

- You can press the **CHRG MODE** key at any time to change back to the float mode.

2.2.4. Choosing the Equalize method

Press the **EQLZ MTHD** key to choose the desired equalize method. The indicator next to the desired equalize method will light. Three equalize methods are available in the AT10.1:

- Manual Timer
- Manual Equalize
- Auto-Equalize Timer

These equalize methods are described below.

Manual Timer Method

Choose the manual timer method if you perform regularly scheduled equalize charging, or if you base your equalize charging on regular readings of the specific gravity of each cell of your battery (for lead-acid batteries). When your battery requires equalize charging, adjust the manual timer to 1-2 hours for each 100 AH of battery capacity (see section 2.3.3 to learn how to adjust the equalize time). The battery manufacturer can help you determine the best equalizing schedule for your battery.

After you select the manual timer method, press the **CHRG MODE** key to put the charger into the equalize mode. The **EQLZ** indicator will light. When the equalize timer is finished, the charger reverts automatically to the float mode, and the **FLOAT** indicator lights.

At any time during the equalize charge, you can switch the charger back to float mode by pressing the **CHRG MODE** key. The **FLOAT** indicator will light.

If there is an ac power failure during a timed equalize charge, the AT10.1 remembers the remaining equalize time. When ac power is restored, it resumes the equalize charge where it left off.

OPERATING THE AT10.1

Manual Equalize Method

Choose the manual equalize method when you want to equalize charge the battery, but only when you are able to monitor the battery voltage and gassing rate. After you select the manual equalize method, press the **CHRG MODE** key to put the charger into the equalize mode. The **EQLZ** indicator will light.

Press the **CHRG MODE** key again to return the charger to the float mode. The **FLOAT** indicator will light.

NOTE: Never leave the AT10.1 unattended in the equalize mode with the manual equalize method selected, because a sustained overcharge may cause permanent damage to the battery.

Auto-Equalize Timer Method

Choose the auto-equalize timer method if you have a *flooded* (non-sealed) battery that is subject to infrequent discharges, or when the battery will be discharged by at least half of its rated capacity during an ac power failure. When ac power is restored to the charger, it turns on in the equalize mode automatically, and the **EQLZ** indicator lights. At the end of the equalize charging-time that you select, the charger reverts automatically to the float mode, and the **FLOAT** indicator lights. At any time during the equalize charge, you can switch the charger back to float mode by pressing the **CHRG MODE** key. The **FLOAT** indicator will light.

Consult your battery manufacturer's instructions before using the auto-equalize timer method with sealed (valve-regulated) lead-acid batteries.

Whenever the ac supply fails for 12 seconds or longer, the auto-equalize timer is enabled. For shorter periods, the timer behaves as shown below:

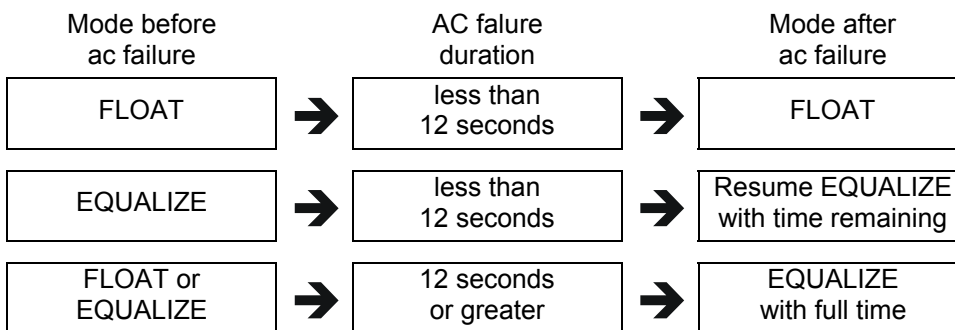

Switching to Equalize Mode with Auto-Equalize Timer Method Selected

You can start an equalize charge at any time.

- Press the **CHRG MODE** key. The **EQLZ** indicator lights.

When the equalize timer is finished, the charger reverts automatically to the float mode, and the **FLOAT** indicator lights.

2.2.5. Testing the front panel indicators

- Press the **DOWN** key. This is also the **LAMP TEST** key.

The meter will display **8888**, and all status & alarm indicators will light.

The **LAMP TEST** key does not test the **AC ON** indicator. The **AC ON** indicator lights whenever ac power is present, and the ac circuit breaker is turned on. The **LAMP TEST** key does not operate when ac power is off.

To test the action of the summary alarm relay, press and hold the **LAMP TEST** key for four seconds. The relay transfers. If you are monitoring the relay with a remote annunciator, it detects the alarm condition.

2.2.6. Testing the Auxiliary Relay Board (optional)

If you have the optional Auxiliary Relay Board installed, you can test the action of the alarm relays. Press and hold the **LAMP TEST** key for four seconds. The six auxiliary alarm relays on the Auxiliary Relay Board transfer. Remote annunciators connected to these relays will indicate this.

2.2.7. Interpreting the alarm indicators

There are six alarm indicators at the right side of the front panel. An indicator lights for each of the following alarm conditions:

- **HIGH DC VOLTAGE**: lights whenever the dc output voltage exceeds the specified alarm voltage setting. See section 2.3.4 to learn how to adjust the HVDC alarm setting.
- **LOW DC VOLTAGE**: lights whenever the dc output voltage is below the specified alarm voltage setting. See section 2.3.4 to learn how to adjust the LVDC alarm setting.
- **DC OUTPUT FAILURE**: lights whenever the charger cannot provide its full rated output voltage *or* its full rated output current. You cannot adjust this alarm setting.
- **AC INPUT FAILURE**: lights whenever the ac power supply to the charger is interrupted.
- **POS GND**: lights whenever leakage current from the battery positive terminal to ground exceeds a specified threshold (see note).
- **NEG GND**: lights whenever leakage current from the battery negative terminal to ground exceeds a specified threshold (see note).

NOTE: You can adjust the sensitivity of the ground fault detection from 5K to 50k ohms. Adjusting the ground fault sensitivity affects the positive and negative ground fault sensitivities equally.

The indicators light immediately when an alarm occurs. The AT10.1 also has a summary alarm relay with one form C contact, rated 0.5A @ 125 Vac/Vdc. If an alarm condition lasts for 30 seconds or longer, the summary alarm relay contact transfers. When the alarm condition is corrected, the relay and all indicators reset automatically.

OPERATING THE AT10.1

2.3. SETTING PARAMETERS IN THE AT10.1

2.3.1. Understanding Parameter Settings

You can change the settings of the AT10.1 while the charger is operating, using the front panel controls. The changes you make take effect immediately, and are saved internally. If the charger is taken out of service, and then later returned to service, it restarts using the last values you set. You can adjust the following parameters:

- Float voltage
- Equalize voltage
- Equalize timer (in hours)
- High dc voltage alarm setting
- Low dc voltage alarm setting
- Current limit value (in Amperes)
- High dc voltage shutdown feature (on or off)

Your choice of equalize method is also saved internally.

When you want to change any parameter, press the **EDIT/ENTER** key to put the AT10.1 into *EDIT* mode. The meter display flashes about once per second, and the status indicators prompt you to adjust the respective parameter. You adjust each parameter by pressing the **UP** or **DOWN** key until the reading you want shows on the meter display. You can make the display scroll up or down continuously by pressing and holding the **UP** or **DOWN** key.

You cannot exceed certain upper and lower limits for the operating parameters. To see what the limits are for your charger, refer to the AT10.1 Specifications in Appendix A on page 70.

When you first press the **EDIT/ENTER** key, the AT10.1 prompts you to adjust the first parameter in the list above (float voltage). When you obtain the value you want on the display, press the **EDIT/ENTER** key again. The AT10.1 saves the new setting internally, and then prompts you to adjust the second parameter. You continue this way to adjust the first six parameters in the list above. If you want to skip adjusting any parameter, just press the **EDIT/ENTER** key again. The AT10.1 moves to the next parameter.

When you are finished adjusting the sixth parameter (current limit), press the **EDIT/ENTER** key again. The AT10.1 saves all adjustments you made internally, and reverts to normal operation. The new settings take effect immediately.

Edit mode ends automatically if you don't press any front panel key within 25 seconds, and any change you made to the last setting is not saved.

2.3.2. Setting the Float and Equalize voltages

- Press the **EDIT/ENTER** key.

The **FLOAT** and **DC VOLTS** indicators light, and the display flashes the present value of the float voltage. Press and release the **UP** or **DOWN** key to increase or decrease the value in the display by one count, or press and hold the **UP** or **DOWN** key to scroll the value in the display upward or downward. When the display shows the float voltage you want to set, release the **UP** or **DOWN** key. If you go past the voltage you want, press the **UP** or **DOWN** key again to reach the voltage you want to set.

- Press the **EDIT/ENTER** key. The new float voltage setting is saved internally.

The **EQLZ** and **DC VOLTS** indicators light, and the display flashes the present value of the equalize voltage. Press and release the **UP** or **DOWN** key to increase or decrease the value in the display by one count, or press and hold the **UP** or **DOWN** key to scroll the value in the display upward or downward. When the display shows the equalize voltage you want to set, release the **UP** or **DOWN** key. If you go past the voltage you want, press the **UP** or **DOWN** key again to reach the voltage you want to set.

- Press the **EDIT/ENTER** key. The new equalize voltage setting is saved internally.

If you want to adjust the equalize timer duration, skip to section 2.3.3.

OR

If you want to exit the Edit mode now, press the **EDIT/ENTER** key four more times until the charger returns to normal operation.

Edit mode ends automatically if you don't press any front panel key within 25 seconds, and any change you made to the last setting is not saved.

OPERATING THE AT10.1

2.3.3. Setting the Equalize Timer

- Press the **EDIT/ENTER** key until the **EQLZ HRS REMAINING**, **MANUAL TIMER** and **AUTO EQLZ TIMER** indicators light, and the display flashes the present value of the equalize timer duration in hours.

Press and release the **UP** or **DOWN** key to increase or decrease the value in the display by one count, or press and hold the **UP** or **DOWN** key to scroll the value in the display upward or downward. When the display shows the equalize time, in hours, that you want to set, release the **UP** or **DOWN** key. If you go past the number of hours you want, press the **UP** or **DOWN** key again to reach the number you want to set.

If you set the equalize time to zero hours, the equalize mode is disabled.

- Press the **EDIT/ENTER** key. The new equalize timer duration is saved internally. The timer setting works for both the manual timer and the auto-equalize timer.

If you want to adjust the alarm settings, skip to section 2.3.4.

OR

If you want to exit the Edit mode now, press the **EDIT/ENTER** key three more times until the charger returns to normal operation.

2.3.4. Setting the Alarms

After you save the equalize timer setting, the Edit mode automatically prompts you to adjust the high dc voltage and low dc voltage alarms. There is a red indicator on the front panel of the AT10.1 for each of the following alarm conditions:

- High DC Voltage
- Low DC Voltage
- DC Output Failure
- AC Input Failure
- Ground Fault Detection (+)
- Ground Fault Detection (-)

The indicators light immediately when an alarm occurs. The AT10.1 also has a summary alarm relay with one form C contact rated 0.5A / 125 Vac/Vdc. If an alarm condition lasts for 30 seconds or longer, the summary alarm relay contact transfers. When the alarm condition is corrected, the relay and all indicators reset automatically. The relay contact also transfers if the AT10.1 detects certain errors, and displays **E 03**, **E 06**, **E 07** or **E 10** on the front panel meter.

Setting the High DC Voltage Alarm

- Press the **EDIT/ENTER** key until the **HIGH DC VOLTAGE** indicator flashes, and the display flashes the present value of the high dc voltage alarm.

Press and release the **UP** or **DOWN** key to increase or decrease the value in the display by one count, or press and hold the **UP** or **DOWN** key to scroll the value in the display upward or downward. When the display shows the high dc voltage alarm point that you want to set, release the **UP** or **DOWN** key. If you go past the voltage you want, press the **UP** or **DOWN** key again to reach the voltage you want to set.

- Press the **EDIT/ENTER** key. The new high dc voltage alarm setting is entered into permanent memory.

Setting the low DC Voltage Alarm

- Press the **EDIT/ENTER** key until the **LOW DC VOLTAGE** indicator flashes, and the display flashes the present value of the low dc voltage alarm.

Press and release the **UP** or **DOWN** key to increase or decrease the value in the display by one count, or press and hold the **UP** or **DOWN** key to scroll the value in the display upward or downward. When the display shows the low dc voltage alarm point that you want to set, release the **UP** or **DOWN** key. If you go past the voltage you want, press the **UP** or **DOWN** key again to reach the voltage you want to set.

- Press the **EDIT/ENTER** key. The new low dc voltage alarm setting is entered into permanent memory.

If you want to adjust the current limit setting, skip to section 2.3.5.

OR

If you want to exit the Edit mode now, press the **EDIT/ENTER** key again to return the charger to normal operation.

OPERATING THE AT10.1

Adjusting Ground Detection Sensitivity

You can adjust the sensitivity of the ground detection alarm circuit. You must have a test resistor whose value is the sensitivity you want. You can adjust the sensitivity from 5 to 50 k Ω .

The potentiometer for adjusting ground detection circuit sensitivity is located on the main control circuit board. It is the lower of the two potentiometers labeled **RA3 SENS**, as shown in the figure at the right.

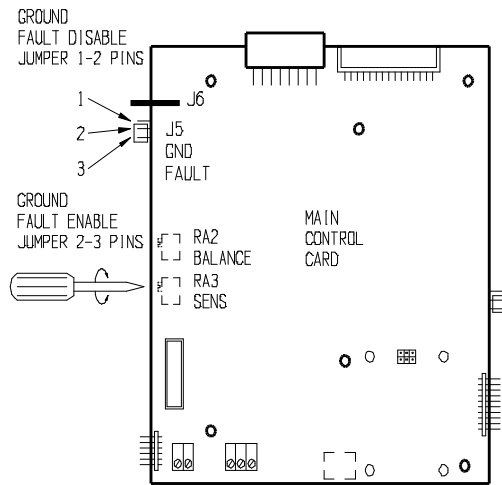

NOTE: Do not try to adjust the upper potentiometer labeled **RA2 BALANCE**. This adjustment is made at the factory for proper circuit operation.

CAUTION: Before connecting or disconnecting a test resistor, de-energize and lock out all ac and dc voltage sources to the AT10.1. Check with a voltmeter before proceeding. Restart the AT10.1 only when necessary to make the sensitivity adjustment. If your battery is grounded, do not attempt this procedure.

Remove the safety cover. Connect the test resistor between **TB1(+)** and chassis ground, as shown to the right. Adjust **RA3** counterclockwise until the front panel indicator goes out, then adjust slowly clockwise until the **POS GND** indicator just lights. Make this adjustment slowly; the indicator is updated once in every four seconds. De-energize and lock out power to the AT10.1, then remove the test resistor and verify that the indicator goes out.

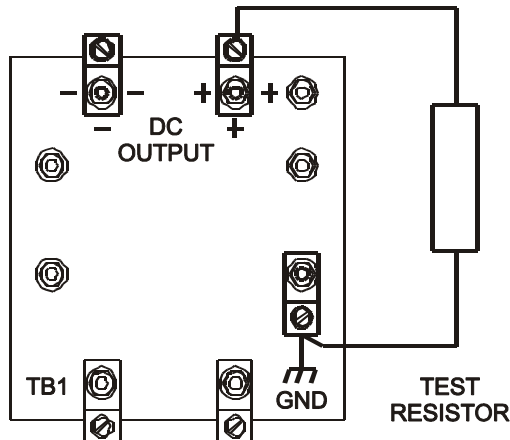

Now connect the test resistor between **TB1(-)** and chassis ground. Verify that the **NEG GND** indicator lights. If not, adjust **RA3** clockwise until it does. Remove the test resistor.

Disabling the Ground Detection Alarm

You can disable the ground detection alarm circuit, and isolate the circuit from chassis ground. If your battery is normally grounded, or you want to defeat the alarm for any other reason, follow these steps:

- De-energize and lock out all ac and dc voltage sources to the AT10.1. Check with a voltmeter before proceeding. This includes remote sense wires if they were installed.
- Open the AT10.1 front panel, and locate jumper **J5** at the top left of the Control Circuit Board (shown on the previous page). Move the jumper to the **DISABLE** position. The **POS GND** and **NEG GND** indicators and the summary alarm relay will not respond to a ground fault.

Restart the AT10.1, following the instructions in section 2.1.

2.3.5. Setting the current limit value

The AT10.1 automatically limits its dc output current in case of overload or battery discharge. You can adjust the value of the current limit from 50% to 110% of rated current. The factory setting is 110%.

The current limit adjustment is the last step in the normal Edit sequence. If the AT10.1 is not in the Edit mode, press the **EDIT/ENTER** key five times, until the meter display flashes the value of current limit, *in Amperes*. Press and release the **UP** or **DOWN** key to increase or decrease the value in the display by one count, or press and hold the **UP** or **DOWN** key to scroll the value in the display upward or downward. When the display shows the current limit value that you want to set, release the **UP** or **DOWN** key. If you go past the number you want, press the **UP** or **DOWN** key again to reach the number you want to set.

- Press the **EDIT/ENTER** key. The new current limit setting is saved internally.

Edit mode ends automatically if you don't press any front panel key within 25 seconds, and any change you made to the last setting is not saved.

OPERATING THE AT10.1

2.3.6. Enabling the High DC Voltage shutdown feature

The AT10.1 has a built-in high dc voltage shutdown feature. In case of any maladjustment or internal failure that results in a continuous output voltage that is too high, the AT10.1 shuts down after 30 seconds to protect the battery. The digital display reads **E 03**, and the summary alarm relay contact transfers.

The AT10.1 is shipped with the high dc voltage shutdown feature disabled.

You can adjust the high dc voltage shutdown (the setting is the same as the high dc voltage alarm setting). Refer to section 2.3.4.

The charger must be in normal operation (not the Edit mode) to enable the high dc voltage shutdown.

To enable the shutdown feature:

- Press and hold the **UP** key, then
- Press the **CHRG MODE** key.

The **HIGH DC VOLTAGE** indicator lights, and the display flashes **ON**. You can toggle the shutdown feature **OFF** and **ON** by pressing the **CHRG MODE** key repeatedly.

If you don't press any key within 4 seconds, the last state indicated (**ON** or **OFF**) is saved internally. Note that you *don't* use the **EDIT/ENTER** key for this feature.

If the AT10.1 shuts down because of a high dc voltage, the meter display shows error code **E 03**. Reset the charger by turning the ac breaker off, then on again.

<p>Parallel Operation</p> <p>If two (or more) AT10.1 chargers are connected in parallel, both sense the output voltage. If one charger runs away, it will supply all the output current; the other has zero output current. The high dc voltage shutdown does not operate in a charger with zero output current, so that only the defective charger (of two or more in parallel) shuts down. The other charger continues to supply the load normally.</p>
--

2.3.7. Adjusting the Voltmeter Accuracy

The AT10.1 voltmeter is adjusted at the factory to display the actual output voltage within $\pm 1\%$. If you replace any component that affects meter accuracy, such as the main control PC board or R4, you should readjust the meter. This adjustment procedure is different from all others, because the meter reading remains constant, while the output voltage of the charger changes. Do this adjustment with a fully charged battery and with no load connected.

First, use the *Edit* procedure to adjust the float voltage to the desired value. See section 2.3.2 for instructions on setting the float voltage. Second, press and hold the **UP** key, then press the **EQLZ MTHD** key.

The **DC VOLTS** **METER MODE** indicator will light, and the meter display flashes the output voltage reading. Measure the output voltage of the AT10.1 using a dc meter accurate to $\pm 0.25\%$ or better.

While watching the meter connected to the AT10.1 output (not the front panel meter), press the **UP** or **DOWN** key until the actual output voltage matches the float setting on the front panel meter.

Each time you press **UP** or **DOWN**, you change the AT10.1 output voltage by a small amount. Continue to press **UP** or **DOWN** until the actual output voltage agrees with the front panel reading within $\pm 1\%$

NOTE: Allow one or two seconds for the output voltage to stabilize each time you press the **UP** or **DOWN** key.

When you are finished adjusting the output voltage, the AT10.1 waits 5 seconds, then the display returns to normal operation.

OPERATING THE AT10.1

2.3.8. Using the Low Level Detector (LLD)

The AT10.1 charger is equipped with a summary alarm safety override circuit. This safety feature forces the summary alarm (common alarm) relay contact to transfer, sending an alarm, even if there is a catastrophic failure of the control circuitry. A low battery voltage triggers the safety circuit.

If you have a dc power supply, you can adjust the battery voltage that triggers the alarm. On the back of the main control circuit board, find the potentiometer **RA1**, as shown in the figure below.

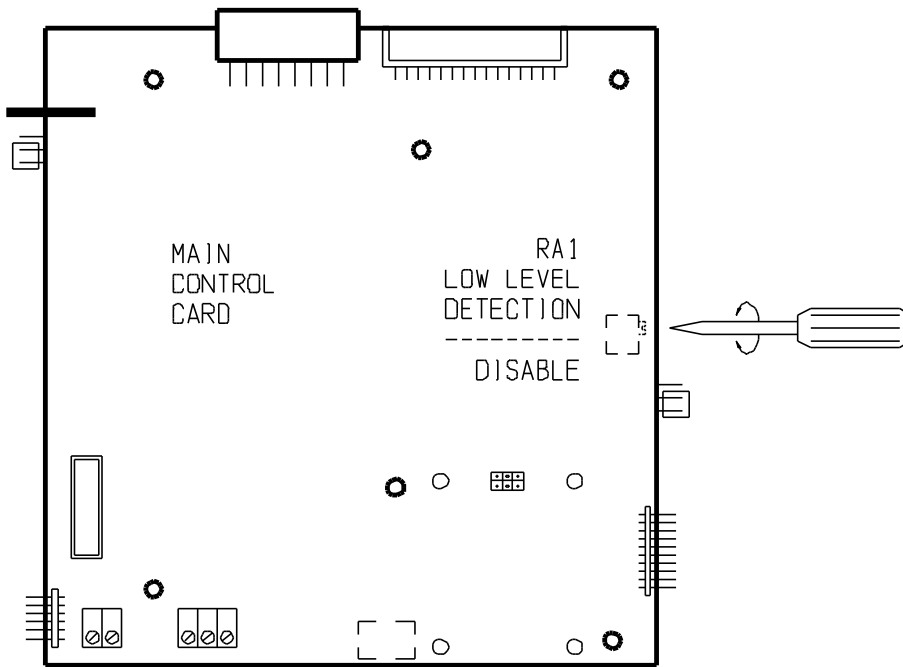

Disconnect all ac and dc power sources from the AT10.1, and connect your dc power supply to the output terminals (positive of the supply to the positive output of the charger). Adjust the power supply to the voltage that you want to activate the alarm.

NOTE: You need at least 50% of the nominal output voltage to power the circuit board.

Adjust **RA1** until the alarm just activates. There is a red LED indicator next to **RA1** that indicates when the alarm is active.

2.3.9. Using the front panel security feature

The AT10.1 charger is shipped with all the front panel keys enabled. You can disable these front panel functions:

- Selecting Equalize method
- Changing settings using the **EDIT/ENTER** key
- Toggling the high dc voltage shutdown feature

Open the front panel, and locate the small plastic jumper **J9** on the right side of the main control board. See the figure below.

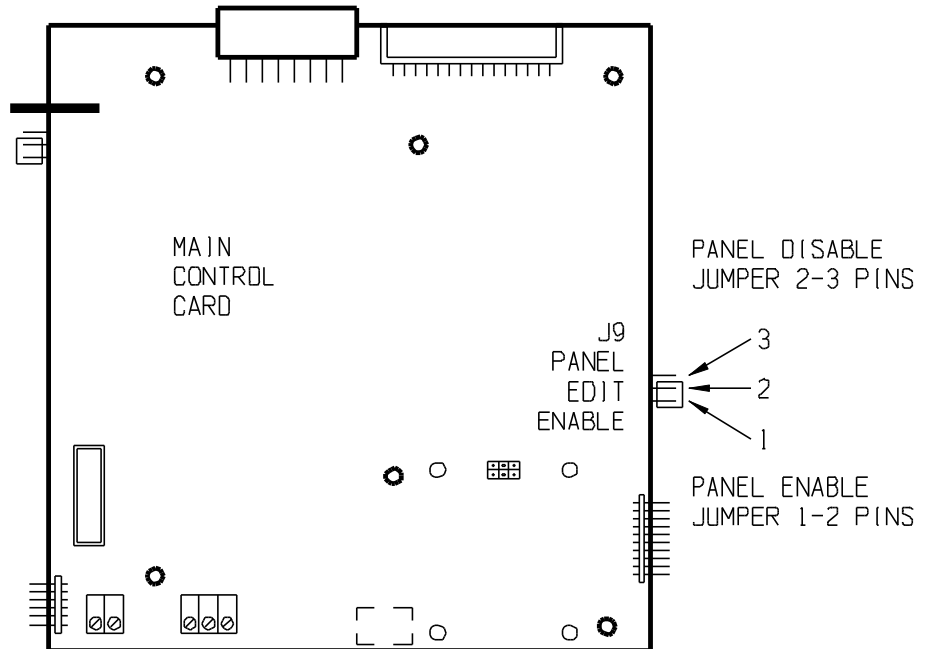

Move the jumper to the **DISABLE** position. Now, only the front panel **METER MODE** and **CHRG MODE** keys work. All indicators still work normally.

OPERATING THE AT10.1

2.4. Performing routine maintenance

WARNING:

High voltages appear at several points inside the battery charger. Use extreme caution when working inside the charger. Do not attempt to work inside the charger unless you are a qualified technician or electrician.

Disconnect and lock out all power to the battery charger before starting any maintenance procedures. Turn the ac power off at the distribution panel upstream from the battery charger. Disconnect the battery from the charger output terminals.

2.4.1. Keep it clean

The AT10.1 charger is cooled by natural convection. At least once a year, vacuum the vents at the top and bottom of the enclosure to ensure that there is an adequate supply of cooling air. If you have an extremely dusty environment (especially if airborne dust is conductive), *carefully* vacuum out the interior. Be sure to clean surfaces of circuit boards, and around electrical terminals.

The AT10.1 is rated for operation up to 122° F / 50° C. If your charger is in a warmer environment, or at an elevation over 3000ft / 914m, contact your sales representative for operating information.

2.4.2. Check power and signal connections

Check the tightness of all field connections inside the charger, and connections to the battery. A loose or corroded connection at the battery terminals can be a fire or explosion hazard, and may cause erroneous operation of the AT10.1 charger.

2.4.3. Check remote sense wiring (optional)

If you wired the AT10.1 charger for remote sense, check the signal connections to the battery or load, and check the wiring to be sure the insulation is in good condition. If there is a failure of the remote sense signal wiring, the AT10.1 charger displays the error code **E 06**, and goes back to local control, sensing the output voltage at the charger output terminals.

2.4.4. Check temperature compensation probe (optional)

If you are using the optional temperature compensation probe, be sure that the probe is securely installed. Be sure the connectors and the wiring from the probe to the AT10.1 charger are in good condition.

If there is a failure of the temperature compensation probe, or the wiring, the AT10.1 charger displays the error code **E 08**.

2.4.5. Measuring the output ripple voltage (filtered models only)

If your AT10.1 charger is a filtered model, at least once a year measure the ac ripple voltage at the battery terminals. Use an rms responding ac voltmeter.¹ The ripple voltage should be no higher than shown in the specifications in Appendix A on page 70, if the battery ampere-hour capacity is at least 4 times the output current rating of the charger.

If you suspect that the output ripple voltage is too high, see "Output ripple voltage too high" of the *Troubleshooting Chart* in section 3.4, page 53.

2.4.6. Viewing the voltage and alarm settings

You can review the parameter settings in the AT10.1 charger by pressing the **EDIT/ENTER** key on the front panel. Each time you press the key, a different parameter displays, in the following order:

- Float voltage
- Equalize voltage
- Equalize time (in hours)
- High dc voltage alarm setting
- Low dc voltage alarm setting
- Current limit, in Amperes

¹ Don't use a dc voltmeter. The ripple voltage on a battery is a very small ac voltage.

OPERATING THE AT10.1

SAMPLE PREVENTIVE MAINTENANCE PROCEDURE

AT10.1 BATTERY CHARGER

Suggested frequency: every 6 months

Maintenance date _____ Performed by _____

Step (standard features)	Instructions	Results
Clean battery charger	<ul style="list-style-type: none"> All vents clean and open. Remove dust and debris from inside of unit. 	<input type="checkbox"/> OK <input type="checkbox"/> OK
Check all electrical connections and wiring	<ul style="list-style-type: none"> TB1 connections all tight. Internal wiring connections tight, slip-on connectors fully seated. Wire and lug insulation in good condition. Terminations at battery or bus are tight and corrosion free. 	<input type="checkbox"/> OK <input type="checkbox"/> OK <input type="checkbox"/> OK
Check ac input voltage	<ul style="list-style-type: none"> Measure at TB1-L1 and TB1-L2 using ac voltmeter. Must be within +10%, -12% of nominal. 	Input _____ Vac
Check dc output voltage	<ul style="list-style-type: none"> Measure at TB1(+) and TB1(-) using dc voltmeter. Should agree with front panel voltmeter within 1%, and must be correct values for your battery. If the AT10.1 is using a temperature compensation probe, see the graph on page 23 to determine the correct battery voltage. You need to know the battery temperature for this step. 	Float _____ Vdc Equal. _____ Vdc
Check ripple voltage	<ul style="list-style-type: none"> Measure at battery terminals using ac voltmeter set to millivolts scale. Check against specification in Appendix A on page 70. 	Ripple _____ mVac
Test font panel indicators	<ul style="list-style-type: none"> Press LAMP TEST key on front panel. 	<input type="checkbox"/> OK
Test common alarm relay	<ul style="list-style-type: none"> Press LAMP TEST key and hold for 4 seconds. Common alarm relay will transfer. 	<input type="checkbox"/> OK

OPERATING THE AT10.1

Exercise front panel controls	<ul style="list-style-type: none"> Switch from float to equalize, then back to float. Turn off the dc circuit breaker. E 07 should appear on display (requires at least 5% of rated output current). Reset breaker. 	<input type="checkbox"/> OK <input type="checkbox"/> OK
	<ul style="list-style-type: none"> Cycle through meter modes. 	<input type="checkbox"/> VOLTS OK <input type="checkbox"/> AMPS OK <input type="checkbox"/> HOURS OK
	<ul style="list-style-type: none"> Cycle through equalize methods. 	<input type="checkbox"/> MANUAL TIMER OK <input type="checkbox"/> MANUAL EQLZ OK <input type="checkbox"/> AUTO EQLZ TIMER OK
	<ul style="list-style-type: none"> Turn off ac circuit breaker. The AC INPUT FAILURE indicator should light. Reset breaker. 	<input type="checkbox"/> Alarm OK
Check voltage and alarm settings	<ul style="list-style-type: none"> Use EDIT/ENTER key to scroll through settings. 	<input type="checkbox"/> FLOAT OK <input type="checkbox"/> EQUALIZE OK <input type="checkbox"/> HVDC alarm OK <input type="checkbox"/> LVDC alarm OK Current limit _____ Adc
Final checks	<ul style="list-style-type: none"> Be sure safety cover is in place. Restore charger to normal operation. Close latch on front panel; close padlock if installed. 	<input type="checkbox"/> OK <input type="checkbox"/> OK <input type="checkbox"/> OK

Step (optional features)	Instructions	Results
Test auxiliary alarm relays	<ul style="list-style-type: none"> Press LAMP TEST key and hold for 4 seconds. Alarm relays will transfer. 	<input type="checkbox"/> OK
Check integrity of remote sense or temperature compensation wiring	<ul style="list-style-type: none"> Remote sense wiring. Temperature compensation wiring. Temperature compensation probe. 	<input type="checkbox"/> OK <input type="checkbox"/> OK <input type="checkbox"/> OK

A full-size reprint of this Preventive Maintenance Procedure is available.
Ask your sales representative for form JD0064.

SERVICING THE AT10.1

3. SERVICING THE AT10.1

3.1. A STEP-BY-STEP TROUBLESHOOTING PROCEDURE

The AT10.1 battery charger is fully tested and calibrated at the factory and should work for years with a minimum of attention. If you do encounter trouble, there are three steps you should take to find the problem and return the charger to service.

1. Check the front panel meter for an error code. The AT10.1 is able to diagnose common problems with the battery charger, or with the application or installation. If the front panel displays an error code, see section 3.2, *Interpreting Front Panel Error Messages*, for help in interpreting the code and solving the problem.
2. If the charger does not work properly, but there is no front panel error code, turn off the front panel circuit breakers (or disconnect ac and dc power externally). Then turn the dc and ac power back on. This will return the charger to normal operation as long as there is no internal component failure.

Note: Do this only once. If the charger does not resume normal operation, go to the next step.

3. If the charger still does not work properly, make a list of the symptoms that you observe, then turn to *Using the troubleshooting chart* in section 3.3. The troubleshooting chart relates common trouble symptoms to their causes, and gives the proper procedures for correcting the problem.
4. If the symptom doesn't appear on the troubleshooting chart, or if the recommended repair doesn't work, consult your sales or service representative to arrange for on-site or factory service.

3.2. INTERPRETING FRONT PANEL ERROR MESSAGES

If the AT10.1 control circuit detects a hardware or wiring problem, it may display an error code on the front panel. To solve the problem, use the table starting below, which lists the error codes and the procedures to use.

WARNING:

High voltages appear at several points inside the battery charger. Use extreme caution when working inside the charger. Do not attempt to work inside the charger unless you are a qualified technician or electrician.

Disconnect and lock out all power from the battery charger before starting to remove or replace any components. Turn the ac power off at the distribution panel upstream from the battery charger. Disconnect the battery from the charger output terminals.

Error Code	Meaning	Repair Procedure
E 01	Resistor R2 open or defective	Resistor R2 is installed at the back of the front panel, in the control circuit board input connector. R2 is measured by the control circuit on startup, and is used to determine some of the AT10.1 charger's parameters, such as the float voltage. If the AT10.1 finds that R2 is defective, it must be replaced. See section 3.6 for parts ordering information. When you have completed the repair, restart the charger according to section 2.1.
E 02	Short circuit on output	You may get this error code if the battery is discharged to less than 6 volts. When the battery charges to greater than 6 volts, the error code disappears. If you have a seriously discharged battery, allow the charger to run for 24 hours and check the battery voltage again. If it has not increased to the normal voltage rating, consult the battery manufacturer for help. If the battery voltage is normal, then check the wiring at the dc output terminals for a short circuit. If the battery voltage is normal and all external wiring is OK, check the dc breaker on the charger. If it is tripped, try once to reset it. If it trips again immediately, there may be an internal short circuit in the charger. Check the internal wiring. If the charger is filtered, check the dc filter capacitors and the polarity diode. The AT10.1 normally recovers automatically from an E 02 condition. If you have shut down the charger for service, restart it according to section 2.1.
E 03	High DC Voltage Shutdown	To restart the charger, turn the ac breaker off, then on. Check the Equalize voltage and High DC Voltage alarm settings. The alarm setting must be higher than the Equalize voltage setting. If you get another High DC Voltage shutdown after a few minutes of operation, there may be an internal component failure. See <i>Charger output not controllable</i> of the troubleshooting chart in section 3.4.

SERVICING THE AT10.1

Error Code	Meaning	Repair Procedure
E 04	Internal memory failure	<p>Any parameters that you set, such as Float or Equalize voltage, are saved internally. The internal memory is tested on startup. If the memory test fails, E 04 appears on the front panel display. The error may also appear if the controller was trying to write to the memory while a power failure occurred.</p> <p>If an E 04 appears, try restarting the AT10.1 by turning the ac and dc breakers off, then on. If the charger restarts normally, you must reenter any changes you made to the factory settings (float voltage, etc.).</p> <p>If E 04 appears repeatedly, the internal memory has been damaged. You must replace the control circuit board. See section 3.6 for parts ordering information.</p>
E 05	Not used	<p>This error code was formerly used to indicate a reverse battery connection. It is not available in the AT10.1.</p>
E 06	R4 or R14 is defective, or remote sense wiring failed	<p>Locate R4 mounted on TB5, on the back of the front panel. Remove the resistor and measure its value with an Ohmmeter (see table 3-1 for the correct value). If the resistor is not within 1% of the specified value, it must be replaced.</p> <p>Locate R14 inside the enclosure, connected to TB1(-). Remove the lugged end and measure the resistor's value with an Ohmmeter (see table 3-1 for the correct value). If the resistor is not within 1% of the specified value, it must be replaced.</p> <p>If you are using remote sense wiring from the battery to the AT10.1, the wiring may have failed. The usual failure is an open circuit; a short circuit will usually be indicated by smoke or fire in the wiring.</p> <p>The AT10.1 charger displays the error code if it detects this wiring failure. You should respond to this problem quickly to be sure that the AT10.1 regulates the output voltage properly. Wire an annunciator (buzzer, e.g.) to the summary alarm relay TB3 to get a remote indication of any charger problem, or monitor the charger operation using the optional DNP-3/MODBUS communications board.</p> <p>If you have a failure in remote sense wiring, the AT10.1 regulates its output voltage locally until you correct the problem, see section 1.9. The locally controlled voltage may not reflect the true requirements of the battery.</p> <p>When you complete the repair, restart the charger as described in section 2.1.</p>
E 07	DC breaker open, or internal failure	<p>If the dc breaker is open, open the ac breaker, then reclose the dc and ac breakers. If the dc breaker trips again, see the troubleshooting chart in section 3.4.</p> <p>If the dc breaker is closed, but you have an E 07 display, check your battery. If the battery is disconnected, and you then disconnect the load, the charger may display an E 07 code. Restart the charger according to section 2.1.</p> <p>If the battery and load are OK, see the troubleshooting chart in section 3.4 for help in locating the problem.</p>

SERVICING THE AT10.1

Error Code	Meaning	Repair Procedure
E 08	Defective temperature compensation probe	<p>If a temperature compensation probe is connected to the AT10.1, the control circuit detects the probe on startup, and uses the temperature measured by the probe to control the output voltage of the charger. To understand temperature compensation, see section 1.11.</p> <p>If the temperature compensation probe, or the wiring that connects it to the AT10.1, fails during normal operation, the AT10.1 detects the failure, and shows E 08 on the front panel meter.</p> <p>Disconnect the wiring from the probe, and measure the resistance of the probe with an Ohmmeter. The resistance should be approximately 10,000 Ohms at normal room temperature (77° F / 25° C). If the probe reads open or shorted, it needs to be replaced.</p> <p>If the probe checks good, examine the wiring between the probe and the AT10.1. Also check the connection of the cable to the control circuit board on the back of the front panel. If the wiring is OK, then the probe needs to be replaced. Once you have replaced the probe, you must restart the AT10.1 to activate temperature compensation.</p>
E 09	Misadjusted current limit	<p>The output current limit is set at the factory to 110% of the rated output current (e.g., for a 20 Adc charger, the current limit is set to 22 Adc). You can adjust the current limit downward to as low as 50% of the output current, if you have special requirements such as limited ac power available. You should do this only if the normal dc load on the system is smaller than the current limit.</p> <p>If the load current becomes larger than the current limit setting, the battery will not charge properly. The charger displays E 09. You should increase the current limit setting to supply the current required by the load.</p> <p><i>NOTE: The common alarm relay is not set for this condition.</i></p>
E 10	Open internal feedback loop	<p>A redundant internal feedback loop (control loop) is provided as redundancy, to increase reliability when remote sensing is used. If there should be a problem with the internal loop wiring, the charger displays E 10. Check the internal wiring in the signal harness, especially wire # 33. Also check the harness connector on the main control circuit board.</p>
A 02	Equalize mode inhibited	<p>If you set the equalize timer to zero hours, the equalize mode is inhibited. When you try to put the charger into equalize mode with a front panel control, the display shows the message A 02. If you want to enable the equalize mode, set the equalize timer to 1 or more hours.</p>

SERVICING THE AT10.1

3.3. USING THE TROUBLESHOOTING CHART

WARNING:

High voltages appear at several points inside the battery charger. Use extreme caution when working inside the charger. Do not attempt to work inside the charger unless you are a qualified technician or electrician.

Disconnect and lock out all power from the battery charger before starting to remove or replace any components. Turn the ac power off at the distribution panel upstream from the battery charger. Disconnect the battery from the charger output terminals.

Before you try to use the troubleshooting chart, be sure that you have followed the steps in section 3.1.

The troubleshooting chart that begins on the next page is divided into three columns. To use the chart:

1. Make a list of the charger's condition, including the trouble symptoms.
2. Find the symptom(s) in the first column of the chart.
3. The middle column contains common causes for the problem you observe, in order of probability.
4. Follow the action described in the right-hand column to correct the problem and return the charger to normal service.

Determining the condition of the charger:

- Is the front panel **AC ON** indicator lit?
- What is the ac voltage at the input terminals (measured with an ac voltmeter)?
- What is the dc voltage at the output terminals (measured with a dc voltmeter)?
- Does the meter on the front panel display any voltage or current?
- Are any alarm indicators lit?
- Do the front panel status indicators work (Charge Mode, for example)?
- Can you change the charger to the Equalize mode and back to Float?
- Is the charger making any noise? Is it unusually loud?
- Is there any sign or smell of smoking or burning?

Refer to the wiring diagrams and parts layout drawings in Appendix C while using the chart. For instructions on replacing components, see section 3.5.

3.4. TROUBLESHOOTING CHART

SYMPTOM	PROBABLE CAUSE	RECOMMENDED ACTION
AC breaker trips immediately	<ol style="list-style-type: none"> 1. Shorted rectifier diode or SCR 2. Defective wiring to T1 or to the rectifier heat sink assembly 3. Defective transformer T1 	<ol style="list-style-type: none"> 1. Test by disconnecting wire # 12 from the rectifier assembly. Measure resistance between the two top rectifier terminals (labeled "AC" on the wiring diagram); it should be at least 100,000 Ohms (check both polarities). Replace rectifier assembly if resistance is low in either direction. 2. Check spacing of terminals; check wiring for signs of insulation damage, burns, etc. Repair as necessary. 3. Test by disconnecting wires from X1, X4, Y1 and Y2. If ac breaker still trips, replace T1.
AC breaker trips after a few minutes	<ol style="list-style-type: none"> 1. Loose connection to breaker 2. Wrong ac voltage, or T1 taps miswired 3. Open SCR 4. SCR not controllable 	<ol style="list-style-type: none"> 1. Check and tighten connections as required. 2. Be sure the T1 primary taps are wired correctly for your input voltage. See section 1.6 for details. 3. Use a clamp-on ammeter to measure the current in wire # 11 or # 12. If it less than 70% of the dc output current, one of the SCRs or diodes is defective. Replace the rectifier module. 4. Disconnect wire # 24 from terminal E3 of the rectifier assembly (near the left front of the enclosure). Restart the charger. If You are able to measure output current, one of the SCRs is defective. Replace the rectifier assembly.
DC breaker trips immediately	<ol style="list-style-type: none"> 1. Battery connected with reverse polarity 2. Defective rectifier bridge (if unfiltered charger) 3. Defective free-wheeling diode in SCR module A16 4. Defective polarity diode (if filter assembly is installed) 5. Defective wiring 	<ol style="list-style-type: none"> 1. Check and correct battery wiring if necessary. 2. Test by disconnecting wire # 12 from the rectifier assembly. Measure resistance between the two top rectifier terminals (labeled "AC" on the wiring diagram); it should be at least 100,000 Ohms (check both polarities). Replace rectifier assembly if resistance is low in either direction. 3. Remove wire # 13 from the rectifier control pc board A3. Test the SCR module's internal free-wheeling diode by measuring the resistance from E2 to E10 on A3 with an Ohmmeter. The reading should be at least 100,000 Ohms in one polarity, and less than 1,000 Ohms in the other polarity. Replace the entire A16 SCR module if it is defective. 4. Remove wire # 15 from terminal E14 on the CR1 heat sink. Measure the resistance from the heat sink to E8 on the rectifier control pc board at the left front of the charger (check both polarities). If the resistance is less than 1,000 Ohms in both directions, replace the filter assembly. 5. Check spacing of terminals; check wiring for signs of insulation damage, burns, etc. Repair as necessary.

SERVICING THE AT10.1

SYMPTOM	PROBABLE CAUSE	RECOMMENDED ACTION
DC breaker trips after a few minutes	1. Loose connection to breaker 2. Open SCR 3. SCR not controllable 4. Defective control circuit board A1	1. Check and tighten connections as required. 2. Use a clamp-on ammeter to measure the current in wire # 12 or # 11 . If it less than 70% of the dc output current, then one of the SCRs or diodes is defective. Replace the rectifier module. 3. Disconnect wire # 24 from terminal E3 of the rectifier assembly (near the left front of the enclosure). Restart the charger. If You are able to measure output current, one of the SCRs is defective. Replace the rectifier assembly. 4. If the front panel meter shows more than 110% of rated dc current, the control board may be defective. Disconnect wire # 24 as above. If the output current goes to zero, replace the control board.
No output current, but ac and dc breakers are on; AC ON lamp is out	1. AC supply failure 2. Input fuse F1 is blown (480 Vac input only) 3. Defective wiring 4. Defective transformer T1	1. If AC ON indicator is out, check feeder circuit breaker or fuse. 2. Remove F1 from its fuseholder (located on the bottom of the enclosure) and check with an Ohmmeter or fuse tester. Replace if required. NOTE: If the new fuse blows, see the sections titled "AC breaker trips immediately" and "AC breaker trips after a few minutes" for further troubleshooting hints. 3. Check terminals and wiring between T1 and the rectifier assembly, inductor L1, dc filter (if present), the dc breaker, and the output terminals. Check wire # 29 from T1-Y1 and wire # 28 from T1-Y2 to the control circuit board connector J1. Repair as necessary. 4. Use an ac voltmeter to measure the ac voltage from T1-X1 to X4. It is normally 50% to 80% higher than the rated dc output voltage. If it is too low, check the wiring of the primary taps. See section 1.6 for details. If it is zero, replace T1.

SERVICING THE AT10.1

SYMPTOM	PROBABLE CAUSE	RECOMMENDED ACTION
<p>No output current, but ac and dc breakers are on; AC ON lamp is on</p>	<ol style="list-style-type: none"> 1. Battery is fully charged 2. Float or Equalize voltage set too low 3. Wrong ac input voltage, or T1 taps mis-wired 4. Defective wiring 5. Defective rectifier bridge 6. Defective control circuit board A1 7. Defective transformer T1 8. Defective inductor L1 or L2 9. Defective CR2 10. Defective dc breaker 	<ol style="list-style-type: none"> 1. This is normal operation in a system with little or no dc load. As long as the charger maintains Float voltage, it is operating normally. 2. Check the Float and Equalize voltages and adjust them if necessary. Consult your battery manufacturer for the proper voltage settings. 3. Be sure the T1 primary taps are wired correctly for your input voltage. See section 1.6 for details. 4. Check terminals and wiring between T1 and the rectifier assembly, inductor L1, dc filter (if present), the dc breaker, and the output terminals. Repair as necessary. 5. Use an ac voltmeter to measure the voltage between terminals E3 and E4 of the rectifier circuit board nearest the front of the charger. If you measure about 1.0 Vrms, but there is no output current, replace the rectifier assembly. 6. If you do not measure any ac voltage in step 5 above, and the battery voltage is less than the Float voltage setting, replace the control circuit board. 7. Use an ac voltmeter to measure the ac voltage from T1-X1 to X4. It is normally 50% to 80% higher than the rated dc output voltage. If it is too low, check the wiring of the primary taps. See section 1.6 for details. If it is zero, replace T1. 8. Disconnect the wiring from L1 and measure the resistance between the terminals. If it is an open circuit, replace L1. Repeat for L2 if the optional dc filter is installed. 9. Disconnect wire # 52 from L1 to CR2, then check CR2 with an Ohmmeter (check both polarities). If CR2 is open, replace the filter assembly. This is a very rare occurrence. 10. Disconnect the battery, and connect a light dc load to the charger. Measure the dc voltage from the input terminal to the output terminal of the circuit breaker, with the breaker on. It is normally no more than 50 millivolts. If it is near the rated output voltage, replace the breaker.
<p>Front panel is dead; ac and dc voltages are present at TB1</p>	<ol style="list-style-type: none"> 1. Control circuit board A1 is not connected 2. Defective control circuit board A1 3. Defective wiring 	<ol style="list-style-type: none"> 1. Make sure the connector at the top edge of the control circuit board is firmly seated. 2. If the AC ON indicator is lit, but the rest of the front panel is dead, replace the control circuit board. 3. Check the harness wiring to the control circuit board connector for signs of insulation damage, burns, etc. Be sure all wires are securely crimped in the connector.

SERVICING THE AT10.1

SYMPTOM	PROBABLE CAUSE	RECOMMENDED ACTION
Front panel dies during ac power failure; dc voltage is present at TB1	<ol style="list-style-type: none"> 1. Defective power resistor R3 2. Defective wiring 	<ol style="list-style-type: none"> 1. Use a dc voltmeter to measure the dc voltage from E17 on the I/O panel to TB1(-). It is normally 12 Vdc when the rated output voltage is at TB1(+) and TB1(-). Remove all power from the charger, and measure the resistance from TB1(+) and E17. See the table in section 3.6 for the proper resistance values. If the resistance is not within 10% of the table value, replace R3. 2. Remove the enclosure shroud, and check the wiring to and from TB1 and the control circuit board for signs of insulation damage or burns. Repair any damaged wiring.
Charger output voltage too high, not controllable	<ol style="list-style-type: none"> 1. Defective SCR 2. R4 or R14 is defective, or wrong value 3. Defective temperature compensation probe (optional) 4. Defective control circuit board A1 	<ol style="list-style-type: none"> 1. Disconnect wire # 24 from terminal E3 of the rectifier assembly (near the left front of the enclosure). Restart the charger. If You are able to measure output current, one of the SCRs is defective. Replace the rectifier assembly. 2. Remove one end of R4 from TB5 (on the back of the front panel). Repeat for R14 connected to TB1(-). Measure their values with an Ohmmeter. See the table in section 3.6 for resistance values. If either resistor is not within 1% of the specified value, it must be replaced. 3. Remove the leads from the probe and measure its resistance. At 77° F / 25° C the resistance should be about 10,000 Ohms. If it is not, replace the probe assembly. 4. If the front panel meter shows more than 110% of rated dc current, the control board may be defective. Disconnect wire # 24 from terminal E3 of the rectifier assembly (near the left front of the enclosure). Restart the charger. If the output current goes to zero, replace the control board.
Output voltage does not agree with front panel meter	<ol style="list-style-type: none"> 1. Temperature compensation probe is installed 2. Circuit board or another component may have been replaced 3. R4 or R14 is defective, or wrong value 4. Defective control circuit board A1 	<ol style="list-style-type: none"> 1. If the optional temperature compensation probe is installed, the output voltage may be different from the selected float or equalize voltage. The difference in the voltages depends on the probe temperature. The front panel meter always displays the proper voltage for 77° F / 25° C. 2. Recalibrate meter as described in section 2.3.7. 3. Remove one end of R4 from TB5 (on the back of the front panel). Repeat for R14 connected to TB1(-). Measure their values with an Ohmmeter. See the table in section 3.6 for resistance values. If either resistor is not within 1% of the specified value, it must be replaced. 4. Turn off both front panel circuit breakers. Then turn on the dc breaker, followed by the ac breaker. If the charger still has the wrong output voltage, replace the control circuit board.

SERVICING THE AT10.1

SYMPTOM	PROBABLE CAUSE	RECOMMENDED ACTION
Charger never reaches float (or equalize) voltage (within 1%)	<ol style="list-style-type: none"> 1. Current limit set too low 2. Defective battery or dc load, or load is too great 3. Wrong ac input voltage, or voltage too low, or T1 wired incorrectly 4. Defective rectifier bridge 5. Defective control circuit board A1 	<ol style="list-style-type: none"> 1. If the AT10.1 is not in the Edit mode, press the EDIT/ENTER key five times, until the meter display flashes the current limit value (in Amperes). If the current limit is less than 110%, adjust it to 110% as described. See <i>Setting the Current Limit Value</i>, section 2.3.5 for details. 2. Check each cell of the battery. If one or more cells are shorted, the charger may not be able to reach the Float voltage. You may have the same problem if the normal load current is more than the rated output current of the charger. 3. Make sure the T1 primary taps are wired correctly for your input voltage. See <i>Changing Transformer Taps</i>, section 1.6 for details. The actual ac input voltage must be at least 88% of the rated value for the charger to produce full output power. 4. Use a clamp-on ammeter to measure the current in wire # 12 or # 11. If it less than 70% of the dc output current, one of the SCRs or diodes is defective. Replace the rectifier module. 5. Turn off both front panel circuit breakers. Then turn on the dc breaker, followed by the ac breaker. If the charger output current is below the current limit value, but it still has the wrong output voltage, replace the control circuit board.
Input current too high	<ol style="list-style-type: none"> 1. Wrong ac input voltage, or transformer T1 wired incorrectly 2. Defective rectifier bridge 3. Defective T1 	<ol style="list-style-type: none"> 1. Be sure the T1 primary taps are wired correctly for your input voltage. See <i>Changing Transformer Taps</i>, section 1.6 for details. The actual ac input voltage must be at least 88% of the rated value for the charger to produce full output power. 2. Disconnect wire # 24 from terminal E3 of the rectifier assembly (near the left front of the enclosure). Restart the charger. If You are able to measure output current, one of the SCRs is defective. Replace the rectifier assembly. 3. Test by disconnecting wires from X1, X4, Y1 and Y2. If ac input current is still too high, replace T1.
Output ripple voltage too high	<ol style="list-style-type: none"> 1. Charger is unfiltered 2. Battery is disconnected or defective 3. Battery too small for charger rating 4. One or more defective filter capacitors, C1 or C2 	<ol style="list-style-type: none"> 1. Verify by checking nameplate against the ordering code on the inside front cover. Order and install filter option if necessary. 2. Be sure battery is connected. Inspect battery according to the manufacturer's instructions. 3. Check the measured ripple against the specification for your AT10.1 model on page 70. The ripple rating is for a battery whose Ampere-hours are four (4) times the charger ampere rating. For a smaller battery, ripple voltage may be higher. 4. Test with capacitance meter; replace as necessary.

SERVICING THE AT10.1

SYMPTOM	PROBABLE CAUSE	RECOMMENDED ACTION
Charger very noisy	<ol style="list-style-type: none"> 1. Loose hardware or enclosure panel 2. Defective rectifier bridge 	<ol style="list-style-type: none"> 1. Remove the enclosure shroud. Check and tighten all component mounting hardware. Replace the shroud, being sure all assembly hardware is secure. 2. Use a clamp-on ammeter to measure the ac current in wire # 11 or # 12 (connected between T1 and the rectifier assembly). If it less than 70% of the dc output current, one of the SCRs or diodes is defective. Replace the rectifier module.
Meter readings are erratic	<ol style="list-style-type: none"> 1. Defective or disconnected battery 2. Defective scaling resistor R4 or R14 3. Defective control circuit board A1 	<ol style="list-style-type: none"> 1. Turn off the charger. With a light dc load connected to the battery, be sure each cell reads the nominal cell voltage (2.0V for lead-acid; 1.25V for Ni-Cd). Restart the charger. Each cell should now read the nominal Float voltage (2.2V for lead-acid; 1.35V for Ni-Cd). 2. Remove one end of R4 from TB5 (on the back of the front panel). Repeat for R14 connected to TB1(-). Measure their values with an Ohmmeter. See the table in section 3.6 for resistance values. If either resistor is not within 1% of the specified value, it must be replaced. 3. If the output voltage is constant, replace the control circuit board.
Lamp test key doesn't work, or some lamps don't light	<ol style="list-style-type: none"> 1. No Vac 2. Control circuit board A1 is not secured to front panel 3. Defective control circuit board A1 	<ol style="list-style-type: none"> 1. The lamp test key doesn't work during an ac power failure. 2. Open the front panel, and be sure that the control circuit board is securely mounted on the standoffs on the back of the panel. All indicators should extend about .125in / 3.2mm through the front of the panel. 3. When you press the LAMP TEST key, if some but not all of the indicators light, or the digital meter does not display all 8's, replace the control circuit board.
One or more front panel keys don't work	<ol style="list-style-type: none"> 1. Front panel is locked 2. Control circuit board A1 is not secured to front panel 3. Defective control circuit board A1 	<ol style="list-style-type: none"> 1. Open the front panel, and be sure that jumper J9 on the main control board is in the ENABLE position. 2. Open the front panel, and be sure that the control circuit board is firmly seated on the standoffs on the back of the panel. Front panel keys must operate freely. 3. Turn off both front panel circuit breakers. Then turn on the dc breaker, followed by the ac breaker. If some of the front panel keys still do not work, replace the control circuit board.
Two chargers are connected in parallel, but only one has output current	<ol style="list-style-type: none"> 1. Check for normal operation of both chargers 	<ol style="list-style-type: none"> 1. The AT10.1 is not designed to share the load current when two or more chargers are connected in parallel, so it is normal for one of a pair to have no output current. You can check the operation of the "off" charger by increasing its Float voltage until it starts to deliver output current. When you have finished the test, be sure both chargers are set to the same Float and Equalize voltages.

SERVICING THE AT10.1

SYMPTOM	PROBABLE CAUSE	RECOMMENDED ACTION
<p>HIGH DC VOLTAGE indicator is on</p>	<ol style="list-style-type: none"> 1. High DC Voltage alarm and Equalize voltage settings are mismatched 2. Defective rectifier bridge 3. Defective control circuit board A1 	<ol style="list-style-type: none"> 1. Be sure that the High DC Voltage alarm setting is higher than the Equalize voltage setting. See sections 2.3.2 and 2.3.4. 2. Disconnect wire # 24 from terminal E3 of the rectifier assembly (near the left front of the enclosure). Restart the charger. If You are able to measure output current, one of the SCRs is defective. Replace the rectifier assembly. 3. Turn off both front panel circuit breakers. Then turn on the dc breaker, followed by the ac breaker. If the charger output voltage is normal, but the HIGH DC VOLTAGE indicator is still on, replace the control circuit board.
<p>No alarm, but output voltage is above High DC Voltage setting</p>	<ol style="list-style-type: none"> 1. Output current is below 2% 2. Defective control circuit board A1 	<ol style="list-style-type: none"> 1. Output current must be greater than 2% of rated current to produce a High DC Voltage alarm. See <i>Parallel Operation</i> in section 2.3.6. 2. Turn off both front panel circuit breakers. Then turn on the dc breaker, followed by the ac breaker. If the charger output voltage is above the alarm setting, but the HIGH DC VOLTAGE indicator still doesn't light, replace the control circuit board.
<p>LOW DC VOLTAGE indicator is on, but ac and dc breakers are closed; ac input voltage is normal; there is output current</p>	<ol style="list-style-type: none"> 1. Battery is discharged 2. Low DC Voltage alarm and Float voltage settings are mismatched 3. Defective rectifier bridge 4. Defective control circuit board A1 5. Defective dc breaker 	<ol style="list-style-type: none"> 1. After an ac power failure, or a battery discharge for any other reason, it may take several hours to recharge the battery. It is normal for the LOW DC VOLTAGE indicator to be on until the battery voltage is above the Low DC Alarm voltage. 2. Be sure that the Low DC Voltage alarm setting is lower than the Float voltage setting. See sections 2.3.2 and 2.3.4. 3. Use a clamp-on ammeter to measure the current in wire # 11 or # 12. If it less than 70% of the dc output current, one of the SCRs or diodes is defective. Replace the rectifier assembly. 4. Turn off both front panel circuit breakers. Then turn on the dc breaker, followed by the ac breaker. If the charger output voltage is normal, but the LOW DC VOLTAGE indicator is still on, replace the control circuit board. 5. Disconnect the battery, and connect a light dc load to the charger. Measure the dc voltage from the input terminal to the output terminal of the circuit breaker, with the breaker on. It is normally no more than 50 millivolts. If it is near the rated output voltage, replace the breaker.

SERVICING THE AT10.1

SYMPTOM	PROBABLE CAUSE	RECOMMENDED ACTION
<p>DC OUTPUT FAILURE indicator is on, but ac and dc breakers are closed; ac input voltage is normal</p>	<ol style="list-style-type: none"> 1. Defective rectifier bridge 2. Defective control circuit board A1 3. Defective transformer T1 4. Defective dc breaker 	<ol style="list-style-type: none"> 1. Use a clamp-on ammeter to measure the current in wire # 12 or # 11. If it is less than 70% of the dc output current, one of the SCRs or diodes is defective. Replace the rectifier module. 2. Turn off both front panel circuit breakers. Then turn on the dc breaker, followed by the ac breaker. If the charger output voltage and current are normal, but the DC OUTPUT FAILURE indicator is still on, replace the control circuit board. 3. Use an ac voltmeter to measure the ac voltage from T1-X1 to X4. It is normally 50% to 80% higher than the rated dc output voltage. If it is too low, check the wiring of the primary taps. See section 1.6 for details. If it is zero, replace T1. 4. Disconnect the battery, and connect a light dc load to the charger. Measure the dc voltage from the input terminal to the output terminal of the circuit breaker, with the breaker on. It is normally no more than 50 millivolts. If it is near the rated output voltage, replace the breaker.
<p>AC INPUT FAILURE indicator is on</p>	<ol style="list-style-type: none"> 1. AC power failure 2. Upstream feed breaker/fuse is tripped 3. Defective wiring 4. Defective control circuit board A1 	<ol style="list-style-type: none"> 1. If the ac input power fails, the front panel AC ON indicator goes out, and the AC INPUT FAILURE indicator goes on. 2. Be sure the front panel ac circuit breaker is closed. Measure the ac voltage at TB1-L1 and L2. If it is zero, check upstream distribution breakers and fuses. 3. Measure ac voltage at T1-H1 and T1-H5. It should be the same as the ac supply voltage. 4. Turn off both front panel circuit breakers. Then turn on the dc breaker, followed by the ac breaker. If the AC ON indicator is on, but the AC INPUT FAILURE indicator is still on, replace the control circuit board.

SERVICING THE AT10.1

SYMPTOM	PROBABLE CAUSE	RECOMMENDED ACTION
<p>POS GND or NEG GND indicator is on</p>	<p>1. Ground fault on external dc bus</p> <p>2. Ground detection circuit needs calibration</p> <p>3. Defective wiring</p> <p>4. Defective control circuit board A1</p>	<p>1. Disconnect the charger from the battery and dc bus, and check the battery and dc bus for a ground fault.</p> <p>2. Calibrate the ground detection sensitivity. See section 2.3.4.</p> <p>3. Disconnect the charger from the battery and dc bus. Turn the charger on, and measure the voltage from TB1(+) to chassis, and from TB1(-) to chassis. The voltage readings should be equal, each approximately half of the total output voltage. If there is more than a 10% imbalance, turn off the charger, and inspect all wiring from TB1 to CB2, the optional dc filter, L1, and the rectifier bridge. Look for evidence of insulation damage, insufficient spacing between terminals and chassis, or wires run too close to metal edges.</p> <p>4. Turn off both front panel circuit breakers. Then turn on the dc breaker, followed by the ac breaker. If you are sure there is no ground fault on the external bus or within the charger, but the POS GND or NEG GND indicator is still on, replace the control circuit board.</p>
<p>Summary alarm relay is in alarm mode, but no front panel alarm indicator is on</p>	<p>1. Defective control circuit board A1</p>	<p>1. Turn off both front panel circuit breakers (or turn off ac and dc power externally if the charger doesn't have breakers). Then turn on the dc breaker, followed by the ac breaker. If the relay remains in alarm mode, check the Low Level Detect indicator on main control board. See section 2.3.8. If no other alarm is on, replace the control circuit board.</p>

SERVICING THE AT10.1

3.5. REPLACING DEFECTIVE COMPONENTS

WARNING:

High voltages appear at several points inside the battery charger. Use extreme caution when working inside the charger. Do not attempt to work inside the charger unless you are a qualified technician or electrician.

Disconnect and lock out all power from the battery charger before starting to remove or replace any components. Turn the ac power off at the distribution panel upstream from the battery charger. Disconnect the battery from the charger output terminals.

NOTE: Refer to the drawings in Appendix C while performing the following procedures.

Removing the safety shield

Some of the repair procedures described below require you to remove the clear plastic safety shield over the I/O (input/output) panel inside the front panel. You remove the shield by taking off the wing nuts on the front. Don't lay the shield on the top of the charger; the top vents are needed for cooling.

CAUTION: Hazardous ac and dc voltages are present on the I/O panel terminals and several internal components.

Removing the enclosure shroud

You may need to remove the enclosure shroud in order to make some internal measurements, and to replace or repair some components.

Remove all power from the charger. Remove the eleven screws that hold the shroud on the rear and bottom of the enclosure, then the two screws on the left side that hold the rectifier heat sink assembly. Support the front panel and lift the shroud straight up to remove it. Be sure to save the plastic washers from the door hinge.

The heat sink assembly is supported from the rear panel. Avoid putting any mechanical stress on the heat sink.

Replacing the enclosure shroud

Lower the shroud onto the enclosure base. Install and tighten the eleven screws that hold the shroud on the rear and bottom of the base before you install the two screws that support the heat sink assembly on the left side wall. Remember to reinstall the plastic washers on the door hinge.

Replacing the control circuit board (A1)

CAUTION: A1 is sensitive to damage from static discharges. Leave the circuit board in its anti-static bag until you are ready to install it. Ground yourself before handling the board by touching the ground stud on the back of the door. Handle the board only by the edges.

Turn off all power to the charger. Disconnect the battery from the output terminals. If the optional temperature compensation probe is installed, disconnect the leads from TB8. Remove the harness plug from the upper left edge of the control circuit board, and unplug wire # **30** from the quick-connect terminal near the upper left corner of the board.

The board is mounted on six plastic standoffs. Compress the tab on each standoff, and pull the board toward you until it clears all the standoffs. Put the replacement board in place with the same orientation, and push it onto the standoffs. Be sure that the board is fully seated on the standoffs. Replace wire # **30** on the quick-connect terminal, and connect the harness plug to the board at the top edge. Replace any optional wiring, such as the temperature compensation probe. See section 2.1 for the steps to restart the charger.

If your charger parameters (float voltage, etc.) are different from the factory preset values, you should program in the new values now. See section 2.3. You should also recalibrate the dc voltmeter according to section 2.3.7.

Replacing the rectifier heat sink assembly (A6)

Refer to the customer instruction supplement JA0086-01 supplied with your replacement rectifier heat sink assembly EJ1243-00.

Deenergize and lock out all ac and dc voltage sources to the AT10.1. This includes remote sense wires if they were installed. Check with a voltmeter before proceeding. Remove the enclosure shroud as described in the previous section. Make sure the rectifier heat sink has cooled and remove the entire assembly by the front edge. Remove all wires attached to the rectifier control pc board as you pull the assembly out of the enclosure.

Hold the replacement rectifier assembly in front of the AT10.1 (in the same orientation as the old), and reconnect all wires removed from the old assembly as you insert it into the enclosure. To ensure correct replacement, see the wiring diagrams in Appendix C of this manual or the customer instruction supplement JA0086-01, supplied with the replacement heat sink assembly. When you are done, check to ensure all wires are connected to the proper terminals, and all lugs are fully seated. If any lug does not fit snugly, disconnect it, carefully tighten the ears of the lug using long-nosed pliers, and reconnect.

SERVICING THE AT10.1

Rotate the rectifier assembly into position in the enclosure. Line up the metal tab with the mounting hole on the back wall of the charger and slide the assembly into position. Replace the shroud as described in the previous section. Tighten all screws and restart the AT10.1.

Replacing the optional dc filter assembly (A7)

The dc filter assembly consists of a diode heat sink, inductor L2, and one or two capacitors installed on a single bracket.

Turn off all power to the charger. Disconnect the battery from the output terminals. Remove the safety shield.

Find the flying lead from the inductor L2 (wire # **50**) and disconnect the other end from the center terminal of inductor L1 (at the upper right corner of the rear panel). Disconnect wire # **15** from the quick-connect terminal at the top center of the diode heat sink, and remove wire # **54** from terminal E7 on the front circuit board on the rectifier assembly. Carefully note which terminal the wire is connected to. Remove the four screws at the top of the dc filter bracket. The bracket and the inductor will both fall forward, away from the rear panel.

Lift the filter bracket up about .25in / 6.4mm to release it from the clips at the bottom of the bracket. Swing the filter assembly outward to the left, rotating it so that the heat sink comes out first and the capacitor(s) last.

Install the replacement filter assembly by inserting the capacitor end first, and rotating the assembly inward so that the heat sink is last to go in. Push the bottom edge of the bracket into the clips in the rear panel, and install the four screws at the top of the bracket.

Connect wire # **15** to the quick-connect terminal at the top center of the diode heat sink. Route the flying lead from the inductor L2 (wire # **50**) and connect it to the center terminal ("2") of the inductor L1. Reconnect wire # **54** to terminal E7 of the front circuit board on the rectifier assembly. Replace the shroud and the safety shield.

Replacing the ac input or dc output circuit breaker (CB1, CB2)

Deenergize and lock out all ac and dc voltage sources to the AT10.1.

Check with a voltmeter before proceeding. This includes remote sense wires if they were installed. Remove the two circuit breaker mounting screws on the front panel, and carefully rotate the circuit breaker upward and pull it out of the charger. Remove the wires from the terminals, one at a time, and transfer the wires to the terminals of the replacement breaker. *Be sure the terminal screws are tight.* Install the replacement breaker into the front panel, rotating it downward into place. Install the two mounting screws.

Replacing the main transformer (T1)

Deenergize and lock out all ac and dc voltage sources to the AT10.1. Check with a voltmeter before proceeding. This includes remote sense wires if they were installed. Remove the enclosure shroud and the safety shield. Disconnect the harness wires # 28 and # 29 from the upper row of transformer terminals. Disconnect wires # 11 and # 12 from the top of the rectifier heat sink. Disconnect harness wires # 3 and # 4 from the lower row of terminals; leave both jumpers in place on the lower row.

Remove the four screws or nuts that secure the transformer to the rear panel. Support the transformer by the top of the core and lift it up to get the bottom bracket off the rear panel. Remove the transformer from the charger.

Check the jumpers on the bottom row of terminals of the replacement transformer. Make sure they are connected to the same terminals as the jumpers on the transformer you just removed from the charger. For details see section 1.6, *Changing the Transformer Taps*.

Hold the replacement transformer with the terminals labeled H1 through H5 at the bottom, facing you. Place the transformer against the rear panel, and slide the bottom of the transformer bracket into the slots on the rear panel. Install the four screws or nuts onto the mounting bracket of the transformer. Rewire the transformer, following the steps above in reverse. Refer to section 1.6, and verify that the transformer is properly connected for your input voltage.

Replacing the ac surge suppressors (VR2, VR4 or VR5)

Turn off all power to the charger. Disconnect the battery from the output terminals. Remove the safety shield.

For **VR2**, remove the hardware from the input terminal L1, and remove the lead of the ac surge suppressor. Install one lead of the replacement surge suppressor onto the L1 terminal. Replace the other wires and the hardware. Repeat procedure for the L2 terminal. Tighten all hardware.

For **VR4**, remove the hardware from the input terminal L1, and remove the lead of the ac surge suppressor. Install one lead of the replacement surge suppressor onto the L1 terminal. Replace the other wires and the hardware. Repeat procedure for the *left* ground stud. Tighten all hardware.

For **VR5**, repeat procedure for the ac surge suppressor connected to the L2 terminal and the *right* ground terminal. Tighten all hardware.

NOTE: The surge suppressors are not polarized.

SERVICING THE AT10.1

Replacing the dc surge suppressor (VR1)

Turn off all power to the charger. Disconnect the battery from the output terminals. Remove the safety shield.

Remove the hardware from the output terminal TB1(+), and remove the lead of the dc surge suppressor. Install one lead of the replacement surge suppressor. Replace the other wires and the hardware. Repeat for the output terminal TB1(-). Tighten all hardware.

NOTE: The surge suppressor is not polarized.

Replacing the dc surge suppressor networks (VR6/C4, VR7/C5)

Replace these networks as assemblies; do not replace individual parts.

Turn off all power to the charger. Disconnect the battery from the output terminals. Remove the safety shield.

To replace the network VR6/C4, remove the hardware from the output terminal TB1(-), and remove the lead of the network. Cut the plastic wire ties holding the assembly tight against the I/O panel. Install one lead of the replacement network. Replace the other wires and the hardware. Repeat for the other lead of the network on the ground terminal. For the VR7/C5 network, use the above procedure, but start with the lead on TB1(+). Tighten all hardware. Replace cut wire ties if possible.

NOTE: The surge suppressor networks are not polarized.

Replacing the power (ballast) resistor (R3)

Turn off all power to the charger. Disconnect the battery from the output terminals. Remove the safety shield.

Locate the power resistor R3. On 130 Vdc chargers, it is mounted on the bracket behind the I/O panel. On all other chargers, it is installed just to the right of the I/O panel. Disconnect the lead of R3 wired to TB1(+), and replace it with the corresponding lead of the replacement power resistor. Remove the other lead of R3 from terminal E17 on the I/O panel and replace it with the remaining lead of the replacement power resistor. Tighten all hardware.

In 12 Vdc through 48 Vdc chargers, align the new R3 next to the I/O panel so that the leads are properly spaced. In 130 Vdc chargers, remove the two screws that mount the old resistor, and put the new resistor in its place. Tighten all hardware.

Replacing the scaling resistor (R4)

Locate the scaling resistor R4 on TB5 on the back of the front panel, just above the control circuit board. The resistor (R4 is the one on the left) is mounted on two quick-connect terminals. Remove the resistor by grasping the terminals by the plastic insulation, and pulling out and downward. Install the replacement resistor by pushing the terminals firmly onto the quick-connect blades on the terminal block.

Replacing the voltage crowbar resistor (R6)

Locate the resistor R6 on TB5 on the back of the front panel, just above the control circuit board. The resistor (R6 is the one on the right) is mounted on two quick-connect terminals. Remove the resistor by grasping the terminals by the plastic insulation, and pulling out and downward. Install the replacement resistor by pushing the terminals firmly onto the quick-connect blades on the terminal block.

Replacing the scaling resistor (R14)

Turn off all power to the charger. Disconnect the battery from the output terminals. Remove the safety shield.

The scaling resistor R14 is connected to TB(-) with a ring lug. The other lead of the resistor is soldered to wire # 20.

Remove the insulating sleeving from the soldered joint to wire # 20 (you may have to remove a harness tie) and cut the resistor lead near the solder joint. Disconnect the lugged-end of **R14** from TB1(-) and discard the old resistor.

Using a soldering iron no larger than 35 Watts, solder the bare lead of the new **R14** to wire # 20. Insulate the joint with plastic electrical tape. Crimp a similar ring lug to the other lead of the new resistor. Connect the lugged end of the new scaling resistor **R14** to TB1(-).

SERVICING THE AT10.1

3.6. ORDERING REPLACEMENT PARTS

To order replacement parts, please provide the following information for each component:

- Circuit symbol from the schematic diagram (see Appendix)
- Factory part number and description, from the table below
- Model number and serial number of your battery charger
- Quantity required

Call your sales representative to place an order for spare parts or replacement parts.

Table 3-1: REPLACEMENT PARTS

Symbol	Description	Factory Part Number				Rec. Spares
		12 Vdc	24 Vdc	48 Vdc	130 Vdc	
A1	Main Control circuit board assembly	EJ1243-10				Y
A5	Auxiliary Relay circuit board assembly	EJ1243-03				Y
A3	Rectifier control circuit board	EJ5093-00				
A6	Rectifier (A3 + A16) / Heat Sink assembly	EJ1243-00				Y
A7	DC Filter assembly	See Table 3-2				
A8	Battery Eliminator Filter assembly (requires filtered charger)	EJ1155-00			EJ1155-01	
A10	Temperature Compensation Probe assembly	See Appendix B, Table 2				
A16	Rectifier SCR module	EJ5094-00				
C1	DC Output Filter capacitor	RP0019-09			RP0019-08	Y
C2	Battery Eliminator Filter capacitor	RP0019-09			RP0019-08	Y
C4	EMI filter capacitor	See VR6/C4				
C5	EMI filter capacitor	See VR7/C5				
CB1	AC breaker (standard) 120/208/240 Vac	See Table 3-3				
CB1	AC breaker (med. AIC) 120/208/240 Vac	See Table 3-4				
CB1	AC breaker (high AIC) 120/208/240 Vac	See Table 3-5				
CB1	AC circuit breaker (med. AIC) 480 Vac	RE0171-00				
CB1	AC circuit breaker (high AIC) 480 Vac	RE0043-00				
CB2	DC circuit breaker (standard)	See Table 3-6				
CB2	DC circuit breaker (medium AIC)	See Table 3-7				
CB2	DC circuit breaker (high AIC)	See Table 3-8				
CR1	Polarity diode	EJ1243-04				Y
CR2	Blocking diode	EJ1243-05				

SERVICING THE AT10.1

Symbol	Description	Factory Part Number				Rec. Spares
		12 Vdc	24 Vdc	48 Vdc	130 Vdc	
F1	480 Vac AC Input Fuse	See Table 3-14				Y
L1	Main Inductor	See Table 3-9				
L2	DC Filter Inductor	See Table 3-13				
P5	Jumper for disabling Ground Detection circuit	RC0100-00				
P7	Jumper for voltage selection on Auxiliary Relay circuit board	RC0100-00				
P9	Jumper for front panel lockout feature on A1	RC0100-00				
R2	Rating resistor	See Table 3-10				
R3	Power resistor	EJ1127-00 18Ω	EJ1127-01 100Ω	EJ1127-02 250Ω	EJ1127-03 750Ω	Y
R4	Scaling resistor (positive side)	EJ1134-00 3160Ω	EJ1134-01 6980Ω	EJ1134-02 14.0KΩ	EJ1134-03 38.3KΩ	
R6	Crowbar resistor	EJ1135-00	EJ1135-01	EJ1135-02	EJ1135-03	
R9	Bleed resistor	EJ1137-00	EJ1137-00	EJ1137-01	EJ1137-02	
R14	Scaling resistor (negative side)	EJ1222-00 3160Ω	EJ1222-01 6980Ω	EJ1222-02 14.0KΩ	EJ1222-03 38.3KΩ	
T1	Main transformer (120/208/240 Vac)	See Table 3-11				
T1	Main transformer (480 Vac)	See Table 3-12				
TB1-X	I/O terminal box lug for #14-6 AWG.	RC0056-04				
TB6	Terminal block for Medium and High AIC circuit breakers	terminal section RC0014-00 (8 req'd) end section RC0014-01 (1 req'd)				
VR1	Output Surge Suppressor	EJ1132-01				Y
VR2	Input Surge Suppressor (120/208/240 Vac)	EJ1132-01				Y
VR2	Input Surge Suppressor (480 Vac)	EJ1132-02				Y
VR3	Input Lightning Arrestor	EJ1074-00				
VR4, VR5	Input Surge Suppressor (120/208/240 Vac)	EJ1132-01				Y
VR4, VR5	Input Surge Suppressor (480 Vac)	EJ1132-02				Y
VR6/C4	EMI Filter Network	EJ5021-01				
VR7/C5	EMI Filter Network	EJ5021-01				

SERVICING THE AT10.1

Table 3-2: DC FILTER ASSEMBLIES (L2/C1/R9/CR1/CR2)

Current Rating	12 Vdc	24 Vdc	48 Vdc	130 Vdc
6A	EJ1072-00	EJ1072-00	EJ1072-02	EJ1072-03
12A	EJ1072-00	EJ1072-00	EJ1072-02	EJ1072-06
16A	EJ1072-01	EJ1072-01	EJ1072-07	EJ1072-04
20A	EJ1072-01	EJ1072-01	EJ1072-07	EJ1072-04
25A	EJ1072-01	EJ1072-01	EJ1072-07	EJ1072-05

Table 3-3: STANDARD AC CIRCUIT BREAKERS (CB1) - 240 Vac

Current Rating	12 Vdc	24 Vdc	48 Vdc	130 Vdc
6A	RE0159-11	RE0159-11	RE0159-11	RE0159-13
12A	RE0159-11	RE0159-11	RE0159-13	RE0159-16
16A	RE0159-11	RE0159-12	RE0159-13	RE0159-19
20A	RE0159-11	RE0159-12	RE0159-14	RE0159-20
25A	RE0159-11	RE0159-12	RE0159-15	RE0159-20

Table 3-4: MEDIUM AMPERE INTERRUPTING CAPACITY AC BREAKERS (CB1) - 240 Vac

Current Rating	12 Vdc	24 Vdc	48 Vdc	130 Vdc
6A	RE0171-00	RE0171-00	RE0171-00	RE0171-01
12A	RE0171-00	RE0171-00	RE0171-01	RE0171-04
16A	RE0171-00	RE0171-00	RE0171-01	RE0171-07
20A	RE0171-00	RE0171-00	RE0171-02	RE0171-08
25A	RE0171-00	RE0171-00	RE0171-03	RE0171-08

Table 3-5: HIGH AMPERE INTERRUPTING CAPACITY AC BREAKERS (CB1) - 240 Vac

Current Rating	12 Vdc	24 Vdc	48 Vdc	130 Vdc
6A	RE0043-00	RE0043-00	RE0043-00	RE0043-01
12A	RE0043-00	RE0043-00	RE0043-01	RE0043-04
16A	RE0043-00	RE0043-00	RE0043-01	RE0043-07
20A	RE0043-00	RE0043-00	RE0043-02	RE0043-08
25A	RE0043-00	RE0043-00	RE0043-03	RE0043-08

SERVICING THE AT10.1

Table 3-6: STANDARD DC CIRCUIT BREAKERS (CB2)

Current Rating	12 Vdc	24 Vdc	48 Vdc	130 Vdc
6A	RE0159-01	RE0159-01	RE0159-01	RE0159-12
12A	RE0159-02	RE0159-02	RE0159-02	RE0159-13
16A	RE0159-03	RE0159-03	RE0159-03	RE0159-14
20A	RE0159-04	RE0159-04	RE0159-04	RE0159-15
25A	RE0159-06	RE0159-06	RE0159-06	RE0159-17

Table 3-7: MEDIUM AMPERE INTERRUPTING CAPACITY DC CIRCUIT BREAKERS (CB2)

Current Rating	12 Vdc	24 Vdc	48 Vdc	130 Vdc
6A	RE0171-00	RE0171-00	RE0171-00	RE0171-00
12A	RE0171-01	RE0171-01	RE0171-01	RE0171-01
16A	RE0171-02	RE0171-02	RE0171-02	RE0171-02
20A	RE0171-03	RE0171-03	RE0171-03	RE0171-03
25A	RE0171-04	RE0171-04	RE0171-04	RE0171-04

Table 3-8: HIGH AMPERE INTERRUPTING CAPACITY DC CIRCUIT BREAKERS (CB2)

Current Rating	12 Vdc	24 Vdc	48 Vdc	130 Vdc
6A	RE0043-00	RE0043-00	RE0043-00	RE0043-00
12A	RE0043-01	RE0043-01	RE0043-01	RE0043-01
16A	RE0043-02	RE0043-02	RE0043-02	RE0043-02
20A	RE0043-03	RE0043-03	RE0043-03	RE0043-03
25A	RE0043-04	RE0043-04	RE0043-04	RE0043-04

Table 3-9: MAIN INDUCTOR (L1)

Current Rating	12 Vdc	24 Vdc	48 Vdc	130 Vdc
6A	AP0928-00	AP0928-00	AP0928-00	AP1122-00
12A	AP0928-00	AP0928-00	AP0928-00	AP0930-00
16A	AP0929-00	AP0929-00	AP0929-00	AP0931-00
20A	AP0929-00	AP0929-00	AP0929-00	AP0931-00
25A	AP0929-00	AP0929-00	AP0929-00	AP0931-00

SERVICING THE AT10.1

Table 3-10: RATING RESISTOR (R2)

Current Rating	12 Vdc	24 Vdc	48 Vdc	130 Vdc
6A	EJ1133-00 34.8 KΩ	EJ1133-05 13.0 KΩ	EJ1133-10 5.11 KΩ	EJ1133-15 1.50 KΩ
12A	EJ1133-01 40.2 KΩ	EJ1133-06 15.4 KΩ	EJ1133-11 6.19 KΩ	EJ1133-16 2.21 KΩ
16A	EJ1133-02 53.6 KΩ	EJ1133-07 19.6 KΩ	EJ1133-12 7.50 KΩ	EJ1133-17 2.74 KΩ
20A	EJ1133-03 78.7 KΩ	EJ1133-08 23.7 KΩ	EJ1133-13 9.09 KΩ	EJ1133-18 3.57 KΩ
25A	EJ1133-04 118 KΩ	EJ1133-09 29.4 KΩ	EJ1133-14 11.0 KΩ	EJ1133-19 4.32 KΩ
Connector terminal extraction tool	Molex Part No. 11-03-0044			

Table 3-11: MAIN TRANSFORMER (T1) - 120/208/240 Vac

Current Rating	12 Vdc	24 Vdc	48 Vdc	130 Vdc
6A	AA0718-00	AA0719-00	AB2023-00	AB1868-00
12A	AA0718-00	AA0719-00	AB2023-00	AB1857-00
16A	AA0720-00	AB1855-00	AB1856-00	AB1858-00
20A	AA0720-00	AB1855-00	AB1856-00	AB1858-00
25A	AA0720-00	AB1855-00	AB1856-00	AB1858-00

Table 3-12: MAIN TRANSFORMER (T1) - 480 Vac

Current Rating	12 Vdc	24 Vdc	48 Vdc	130 Vdc
6A	AA0733-00	AA0734-00	AB2038-00	AB2039-00
12A	AA0733-00	AA0734-00	AB2038-00	AB2032-00
16A	AA0735-00	AB2035-00	AB2036-00	AB2037-00
20A	AA0735-00	AB2035-00	AB2036-00	AB2037-00
25A	AA0735-00	AB2035-00	AB2036-00	AB2037-00

SERVICING THE AT10.1

Table 3-13: FILTER INDUCTOR (L2)

Current Rating	12 Vdc	24 Vdc	48 Vdc	130 Vdc
6A	AP0928-00	AP0928-00	AP0928-00	AP1081-00
12A	AP0928-00	AP0928-00	AP0928-00	AP0928-00
16A	AP0927-00	AP0927-00	AP0926-00	AP0926-00
20A	AP0927-00	AP0927-00	AP0926-00	AP0926-00
25A	AP0927-00	AP0927-00	AP0926-00	AP0926-00

Table 3-14: 480 Vac INPUT FUSE (F1)

Current Rating	12 Vdc	24 Vdc	48 Vdc	130 Vdc
6A	RE0008-00	RE0008-00	RE0008-02	RE0008-06
12A	RE0008-00	RE0008-02	RE0008-06	RE0008-08
16A	RE0008-02	RE0008-06	RE0008-08	RE0008-09
20A	RE0008-02	RE0008-06	RE0008-08	RE0008-11
25A	RE0008-02	RE0008-06	RE0008-08	RE0008-11

APPENDIX A

SPECIFICATIONS

All specifications apply at 77° F / 25 °C, 120 Vac, nominal Float voltage except as noted

Specification	Conditions	12 Vdc	24 Vdc	48 Vdc	130 Vdc
Output voltage regulation	Vac +10%, -12% 0 to 100% load Temp. 32-122° F / 0-50° C Freq. 60 ± 3 Hz	± 0.25%			
Transient response	20-100% load change, with battery connected	Output voltage change ± 4% maximum Recovery to ± 2.0% in 200 ms Recovery to ± 0.5% in 500 ms			
Efficiency	12 Adc rating, full load, %	67.00	72.00	78.00	85.00
	25 Adc rating, full load, %	73.00	77.00	85.00	91.00
Output ripple voltage (per NEMA PE5-1996)	Unfiltered, with battery	2% (typ) at battery terminals			
	Filtered, with battery	30 mV rms (max) at battery terminals			
	Filtered, without battery	1% rms (typ)			
	With battery eliminator option (without battery)	30 mV			100 mV
Current limit	Adjustable	50-110 % of rated output current			
Soft start	0 to 100% load	4 seconds			
Voltage adjustment ranges	Float	11.5-14.5	23.0-29.5	46-58	115-140
	Equalize	12-15.5	24-31	48-61	124-143
	High DC Voltage alarm	12-19	24-38	48-76	120-175
	Low DC Voltage alarm	7-12	15-24	30-48	80-120
Voltmeter range (Vdc)		0 - 21	0 - 42	0 - 75	0 - 195
Ammeter range (Adc)	All ratings	0 - 30			
Surge withstand capability	Test per ANSI C37.90.1-1989	No erroneous outputs			
Reverse current from battery	AC input power failure	90 mA maximum			
Audible noise	Average for 4 sides, 5ft / 1.5m from charger	Less than 62 dB(A)			
Cooling		Natural convection			
Ambient temperature	Operating	32-122° F / 0-50° C			
Elevation		3000ft / 1000m without derating			
Relative humidity		0 to 95% non-condensing			
Alarm relay contact rating	120 Vac / 125 Vdc	0.5 A resistive			

FIELD INSTALLABLE ACCESSORIES AND OPTIONS

All accessories/options listed below are available in kits for field installation. Kits contain all parts and hardware with detailed installation instructions. To order accessories/options, please provide the following information for each kit:

- Factory part number and description, from the table below
- Model number and serial number of your battery charger
- Quantity required

Contact your sales representative to place an order for accessories/options.

Description	Kit Part Number
Auxiliary Relay PC Board (A5) for standard circuit breakers	EI0213-00
Auxiliary Relay PC Board (A5) for med/high AIC circuit breakers	EI0213-01
Standard DC Output Filtering (30 mV RMS with battery)	See table 3-2
Battery Eliminator Filtering	See table 3-1
Remote Temperature Compensation Probe Assembly (A10)	See below
AC Input Lightning Arrestor (VR3)	EJ1074-00
Copper Ground Buss with one (1) box lug for #14-6 AWG.	EI0195-00
Floor Mounting Kit for Style-586/594 Cabinet	EI0192-00
Relay Rack Mounting Kit for Style-586/594 Cabinet	EI0193-00
Drip Shield Assembly for Style-586/594 Cabinet	EI0191-00
Cabinet Heater Strip Assembly for Style-586/594 Cabinet	EJ1223-00
NEMA-4/12/13 Type Enclosure for Style-586/594 Cabinet	EI0214-00
Padlock for Front Door	EI0215-00
DNP3 Level 2 / Modbus Communications Module	See Appendix E

Temperature Compensation Assembly

The temperature compensation assembly consists of two (2) components:

1. To order a replacement probe (or puck), request part number EJ5032-00. This probe is good for all charger output voltages and all battery types.
2. The standard temperature compensation assembly is supplied with a 25ft / 7.6m interconnection cable. If you need a longer cable, order it from the table below, which also shows the ordering part number for a complete probe kit.

Temperature Compensation Probe Kits

Cable Length (feet / m)	Kit Part Number (includes probe)	Replacement Cable Part Number
25 / 7.6	EJ5033-00	EJ5011-00
50 / 15.2	EJ5033-01	EJ5011-01
100 / 30.5	EJ5033-02	EJ5011-02
200 / 61.0	EJ5033-03	EJ5011-03

Use a single cable assembly. Do not try to splice cables together to increase the length.

APPENDIX C (Standard Drawings)

Outline - AT10.1 Group I Battery Charger: NEMA-1 Style-586 (JE5023-03)

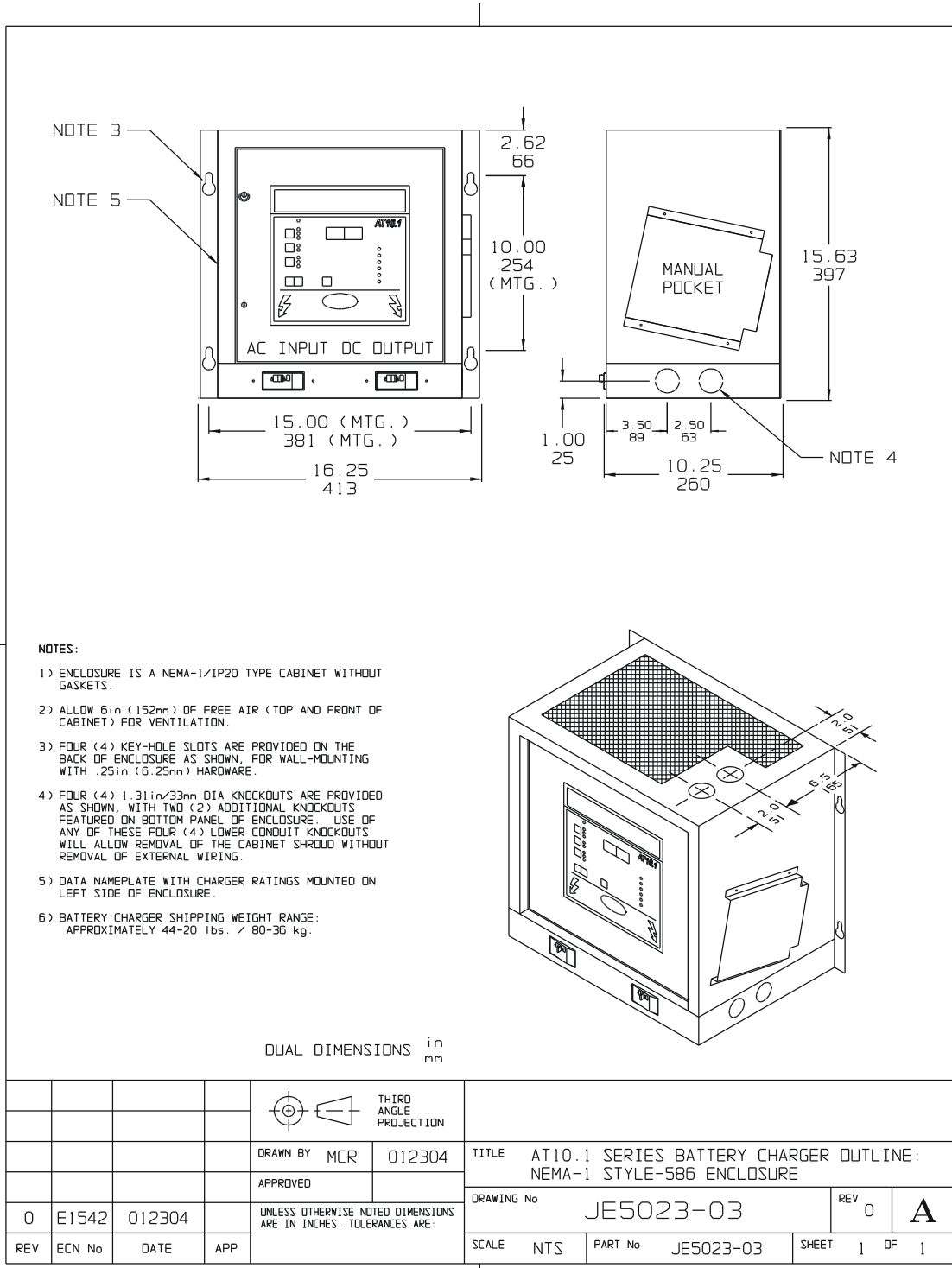

Note: Online standard drawings, saved in **Adobe Acrobat** Portable Document Format (**PDF**), for the AT10.1 Series Battery Charger are available for downloading and printing. Please contact your sales representative for document availability or see the manufacturer's web site listed on the back cover of this manual.

APPENDIX C (Standard Drawings)

Outline - AT10.1 Group I Battery Charger: NEMA-1 Style-594 (JE5024-03)

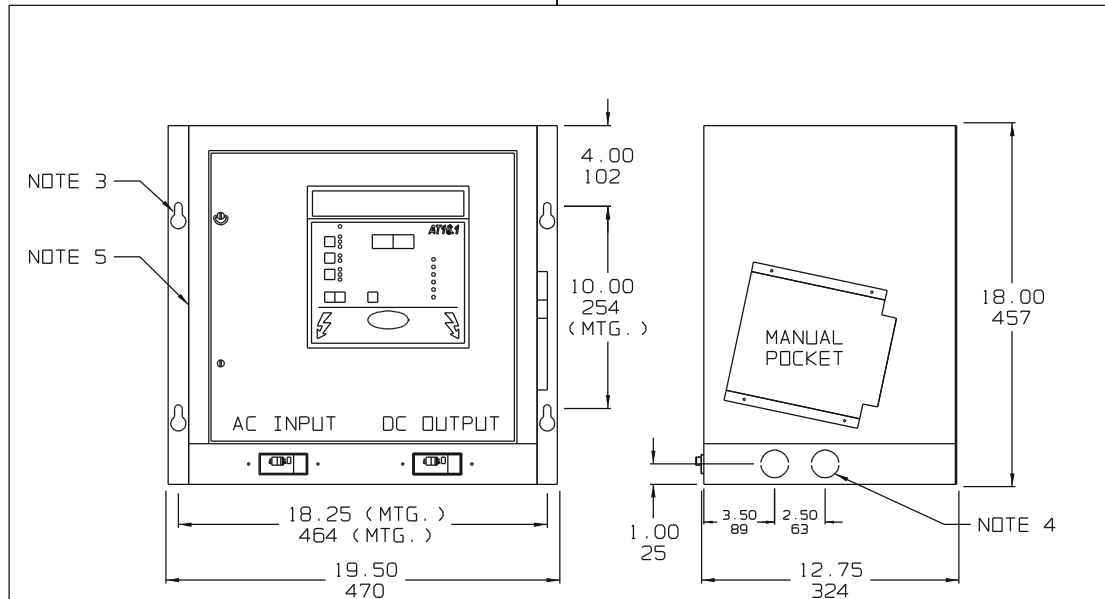

NOTES:

- 1) ENCLOSURE IS A NEMA-1/IP20 TYPE CABINET WITHOUT GASKETS.
- 2) ALLOW 6in (152mm) OF FREE AIR (TOP AND FRONT OF CABINET) FOR VENTILATION.
- 3) FOUR (4) KEY-HOLE SLOTS ARE PROVIDED ON THE BACK OF ENCLOSURE AS SHOWN, FOR WALL-MOUNTING WITH .25in (6.25mm) HARDWARE.
- 4) FOUR (4) 1.31in/33mm DIA KNOCKOUTS ARE PROVIDED AS SHOWN, WITH TWO (2) ADDITIONAL KNOCKOUTS FEATURED ON BOTTOM PANEL OF ENCLOSURE. USE OF ANY OF THESE FOUR (4) LOWER CONDUIT KNOCKOUTS WILL ALLOW REMOVAL OF THE CABINET SHROUD WITHOUT REMOVAL OF EXTERNAL WIRING.
- 5) DATA NAMEPLATE WITH CHARGER RATINGS MOUNTED ON LEFT SIDE OF ENCLOSURE.
- 6) BATTERY CHARGER SHIPPING WEIGHT RANGE: APPROXIMATELY 110-193 lbs. / 50-88 kg.

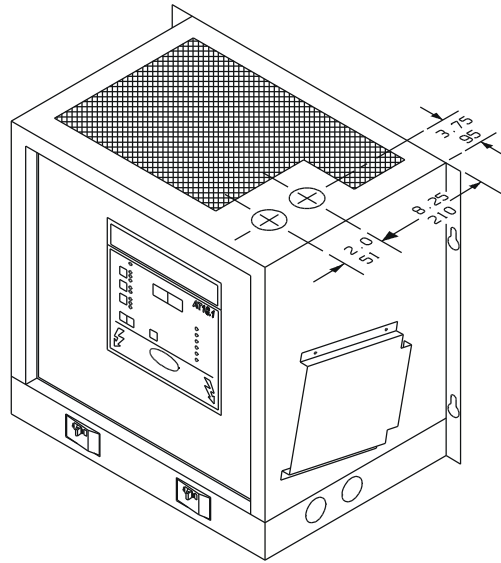

DUAL DIMENSIONS in mm

				THIRD ANGLE PROJECTION						
				DRAWN BY MCR APPROVED	012304	TITLE AT10.1 SERIES BATTERY CHARGER OUTLINE: NEMA-1 STYLE-594 ENCLOSURE				
0	E1542	012304		UNLESS OTHERWISE NOTED DIMENSIONS ARE IN INCHES. TOLERANCES ARE:		DRAWING No JE5024-03		REV 0	A	
REV	ECN No	DATE	APP			SCALE NTS	PART No JE5024-03	SHEET 1 OF 1		

FILENAME [JE5024-03.PRT]

Note: Online standard drawings, saved in **Adobe Acrobat** Portable Document Format (**PDF**), for the AT10.1 Series Battery Charger are available for downloading and printing. Please contact your sales representative for document availability or see the manufacturer's web site listed on the back cover of this manual.

APPENDIX C (Standard Drawings)

AT10.1 Optional Enclosure Outline Drawings Style-586 with Penthouse and Drip Shield

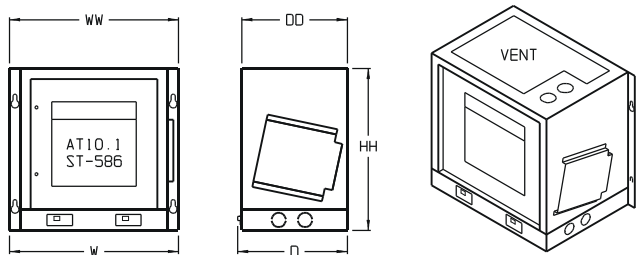
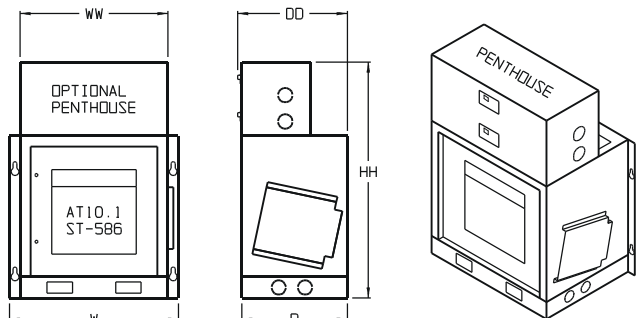
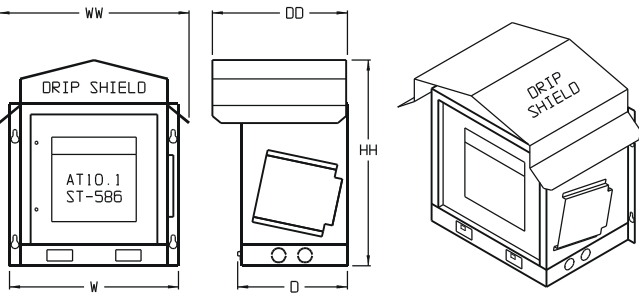
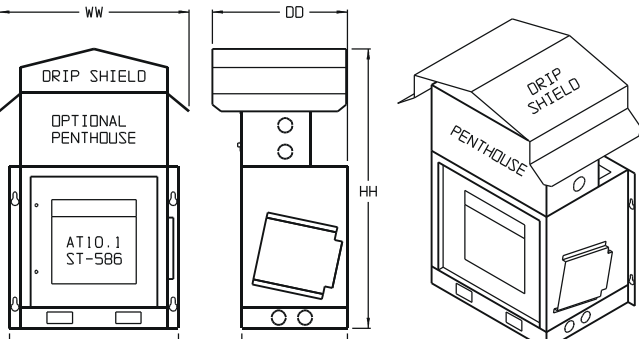
	DIMENSION		
	in	mm	
	Standard		
	WW	16.25	495
	DD	12.50	324
	H	15.63	457
	W D	16.25 10.75	495 337
	with Penthouse		
	WW	14.00	356
	DD	10.75	337
	H	22.63	572
	W D	16.25 10.00	495 324
	with Drip Shield		
	WW	18.75	559
	DD	12.50	318
	H	19.50	552
	W D	16.25 10.75	495 337
	with Penthouse & Drip Shield		
	WW	18.75	476
	DD	12.50	337
	H	26.50	729
	W D	16.25 10.00	495 324

APPENDIX C (Standard Drawings)

AT10.1 Optional Enclosure Outline Drawings Style-594 with Penthouse and Drip Shield

			DIMENSION	in	mm
			Standard		
	WW		19.50	495	
	DD		12.75	324	
	H		18.00	457	
	W		19.50	495	
	D		13.25	337	
			with Penthouse		
	WW		14.00	356	
	DD		13.25	337	
	H		25.00	635	
	W		19.50	495	
	D		12.75	324	
			with Drip Shield		
	WW		22.00	559	
	DD		12.50	318	
	H		21.75	552	
	W		19.50	495	
	D		13.25	337	
			with Penthouse & Drip Shield		
	WW		18.75	476	
	DD		13.25	337	
	H		28.75	729	
	W		19.50	495	
	D		12.75	324	

APPENDIX C (Standard Drawings)

Internal Component Layout Detail - AT10.1 Group I Battery Charger w/Common Options (JE5027-99)

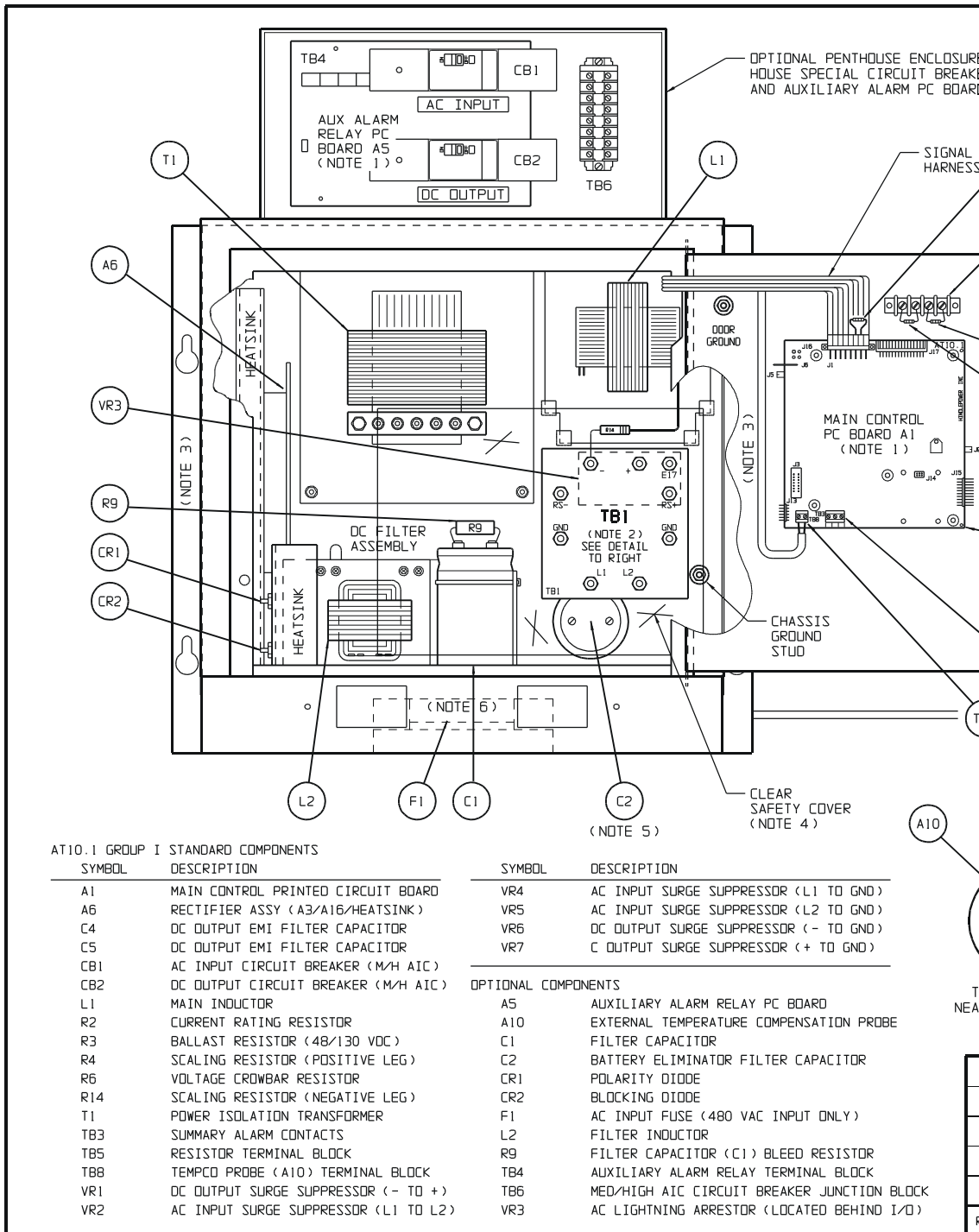

Note: Online standard drawings, saved in **Adobe Acrobat** Portable Document Format (PDF), for the AT10.1 Series Battery Charger are available for downloading and printing. Please contact your sales representative for document availability or see the manufacturer's web site listed on the back cover of this manual.

APPENDIX C (Standard Drawings)

Internal Component Layout Detail - AT10.1 Group I Battery Charger w/Common Options (JE5027-99)

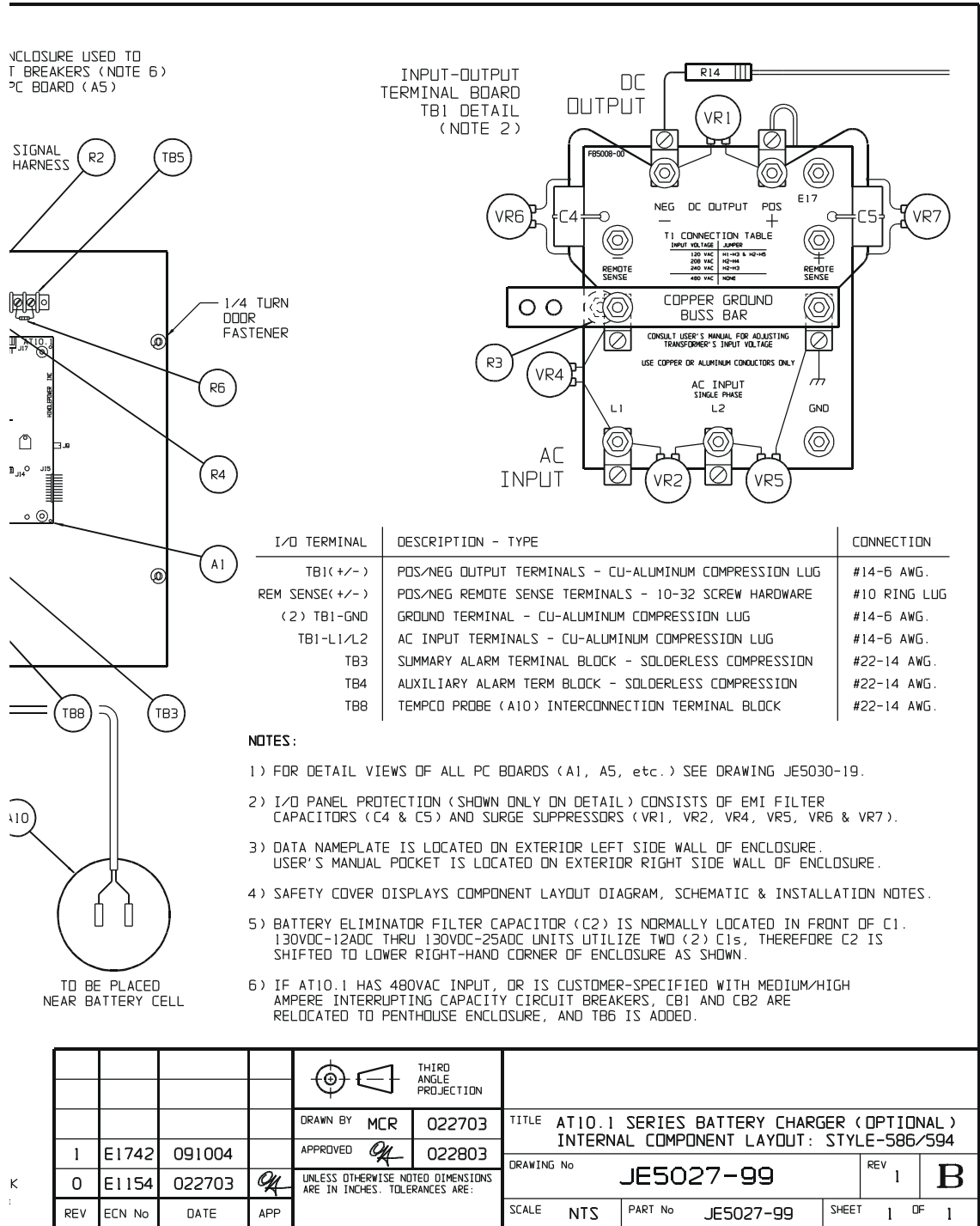

Note: This particular internal component layout drawing (JE5027-99) depicts an AT10.1 Group I battery charger with ALL available options. Standard components (A1 through VR7) are featured in all Group I units. Optional components (A5 through VR3) are featured only on those AT10.1 battery chargers configured with such options.

APPENDIX C (Standard Drawings)

Instrument Panel Detail - AT10.1 Group I Battery Charger w/Optional Auxiliary Relay PC Board (JE5030-19)

- INDICATOR LIGHTS:
- DS01 - AC ON
 - DS02 - DC VOLTS
 - DS03 - DC AMPS
 - DS04 - EQUALIZE HOURS REMAINING
 - DS05 - FLOAT
 - DS06 - EQUALIZE
 - DS07 - MANUAL TIMER
 - DS08 - MANUAL EQUALIZE
 - DS09 - AUTO EQUALIZE TIMER
 - DS10 - LOW LEVEL DETECT
 - DS11 - (METER DISPLAY)
 - DS12 - (METER DISPLAY)
 - DS13 - HIGH DC VOLTAGE
 - DS14 - LOW DC VOLTAGE
 - DS15 - DC OUTPUT FAILURE
 - DS16 - AC INPUT FAILURE
 - DS17 - POSITIVE GROUND
 - DS18 - NEGATIVE GROUND

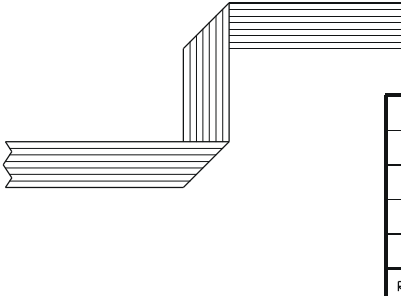
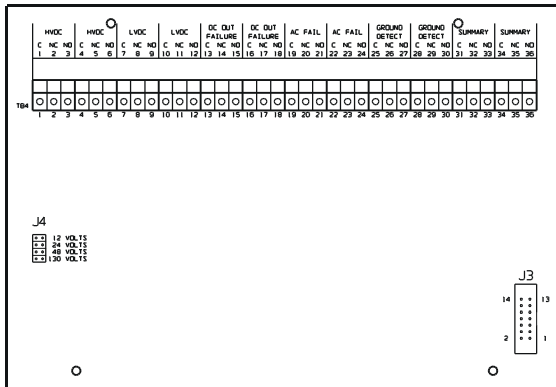
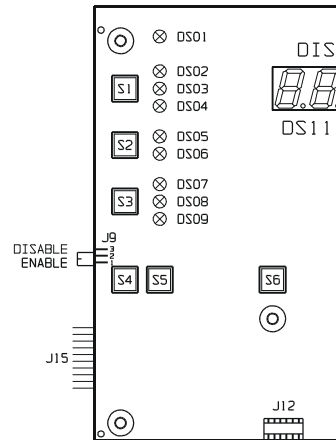
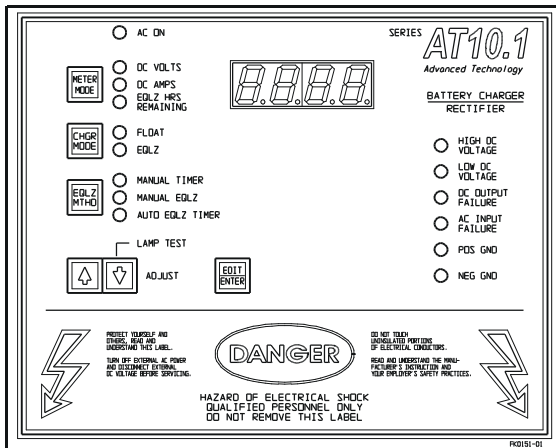

JU
J
J
J
J
J
J
J
J
J
J
J
J

Note: Online standard drawings, saved in Adobe Acrobat Portable Document Format (PDF), for the AT10.1 Series Battery Charger are available for downloading and printing. Please contact your sales representative for document availability or see the manufacturer's web site listed on the back cover of this manual.

APPENDIX C (Standard Drawings)

Instrument Panel Detail - AT10.1 Group I Battery Charger w/Optional Auxiliary Relay PC Board (JE5030-19)

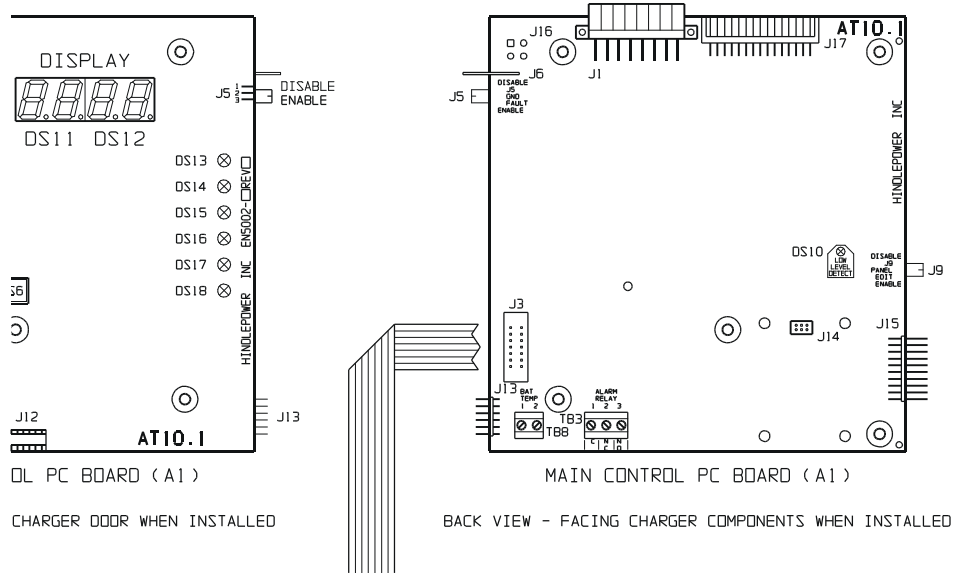

DL PC BOARD (A1)

CHARGER DOOR WHEN INSTALLED

MAIN CONTROL PC BOARD (A1)

BACK VIEW - FACING CHARGER COMPONENTS WHEN INSTALLED

- JUMPERS:**
- J1 - MAINFRAME SIGNAL HARNESS
 - J3 - AUXILIARY ALARM RELAY BOARD (A5) INTERCONNECTOR
 - J5 - GROUND FAULT
 - J6 - EARTH GROUND
 - J9 - FRONT PANEL LOCKOUT
 - J12 - BOARD PROGRAMMING
 - J13 - COMMUNICATIONS BOARD (A12) INTERCONNECTOR
 - J14 - FORCED LOAD SHARING BOARD (A13) INTERCONNECTOR
 - J15 - MANUFACTURING TEST
 - J16 - (RESERVED)
 - J17 - GATE DRIVE BOARD (A11) INTERCONNECTOR

- SWITCHES:**
- S1 - METER MODE
 - S2 - CHARGER MODE
 - S3 - EQUALIZE METHOD
 - S4 - Δ ADJUST
 - S5 - ∇ ADJUST
 - S6 - EDIT / ENTER

- TERMINAL BLOCKS:**
- TB3 - SUMMARY ALARM RELAY CONTACTS
 - TB4 - AUXILIARY ALARM RELAY CONTACTS
 - TB8 - OPTIONAL TEMPCO PROBE (A10) INTERCONNECTION TERMINAL BLOCK

NOTE: UNLESS OTHERWISE SPECIFIED, ALL ALARM TERMINAL BLOCKS (TB3/TB4/TB8) ARE SOLDERLESS COMPRESSION TERMINALS. CONTACT RATING IS 0.5A @ 125VAC/DC, ACCEPTING #22-14 AWG. WIRE.

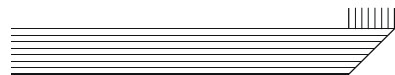

				 THIRD ANGLE PROJECTION						
				DRAWN BY MCR APPROVED	022003	TITLE AT10.1 SERIES BATTERY CHARGER INSTRUMENT PANEL / PC BOARD DETAIL				
0	E1141	022003		UNLESS OTHERWISE NOTED DIMENSIONS ARE IN INCHES. TOLERANCES ARE:		DRAWING No JE5030-19		REV 0	B	
REV	ECN No	DATE	APP			SCALE NTS	PART No JE5030-19	SHEET 1	OF 1	

Note: This instrument panel drawing (JE5030-19) depicts the optional Auxiliary Alarm Relay PC Board (A5), which provides two (2) sets of individual form-c contacts (TB4) for all alarm conditions. Standard AT10.1 battery chargers feature one (1) set of form-c summary (common) alarm contacts (TB3).

APPENDIX C (Standard Drawings)

Schematic - AT10.1 Group I Battery Charger Standard w/o Options (JE5031-00)

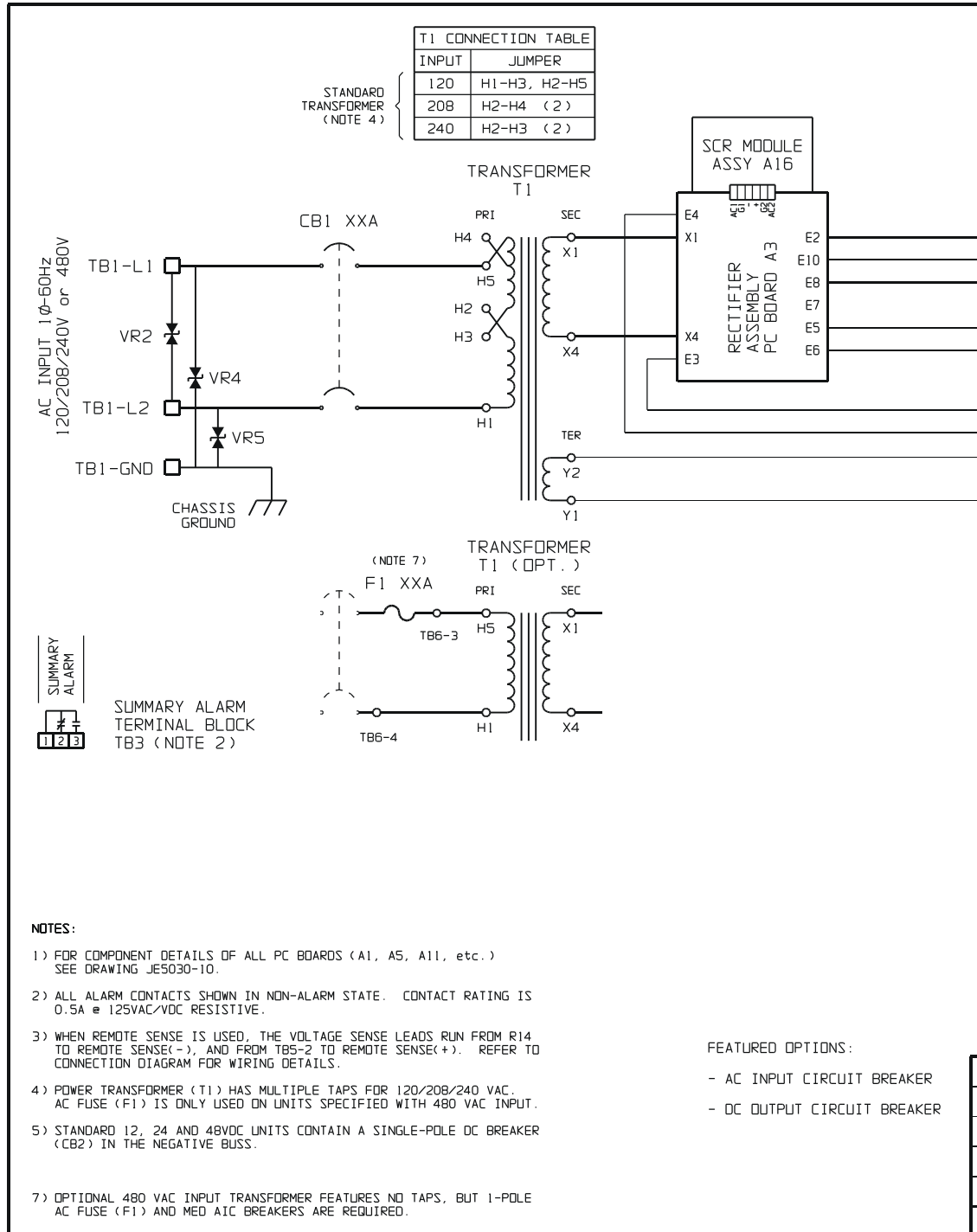

Note: Online standard drawings, saved in **Adobe Acrobat** Portable Document Format (**PDF**), for the AT10.1 Series Battery Charger are available for downloading and printing. Please contact your sales representative for document availability or see the manufacturer's web site listed on the back cover of this manual.

APPENDIX C (Standard Drawings)

Schematic - AT10.1 Group I Battery Charger Standard w/o Options (JE5031-00)

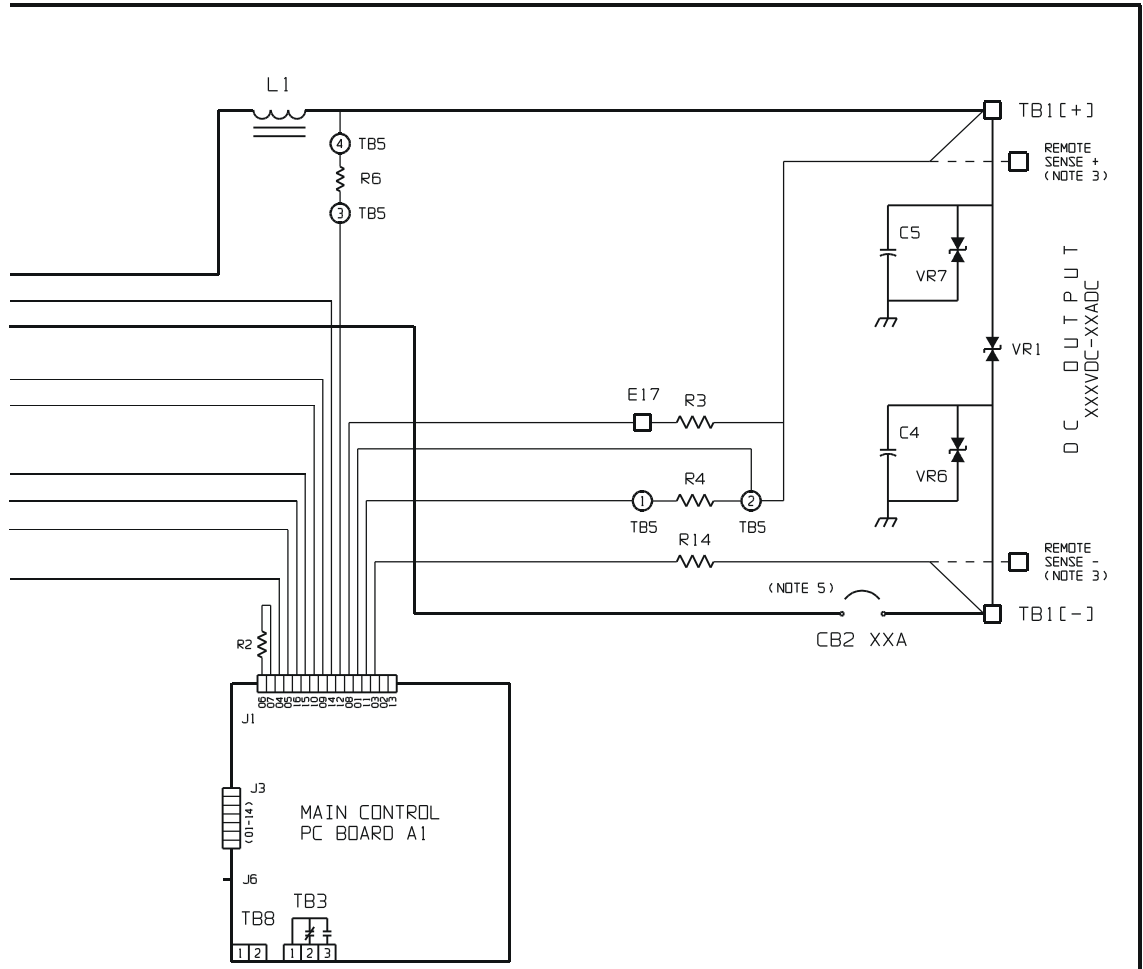

R ER					 THIRD ANGLE PROJECTION						
	2	E1742	091004		DRAWN BY	MCR	022003	TITLE AT10.1 SERIES BATTERY CHARGER: SCHEMATIC: 6-25ADC (GROUP I) STD - W/O OPTIONS			
	1	E1203	040703	<i>OK</i>	APPROVED	<i>OK</i>	022003	DRAWING No JE5031-00 REV 2 B			
	0	E1142	022003	<i>OK</i>	UNLESS OTHERWISE NOTED DIMENSIONS ARE IN INCHES. TOLERANCES ARE:			SCALE NTS PART No JE5031-00 SHEET 1 OF 1			
	REV	ECN No	DATE	APP							

APPENDIX C (Standard Drawings)

Schematic - AT10.1 Group I Battery Charger with Common Options (JE5031-99)

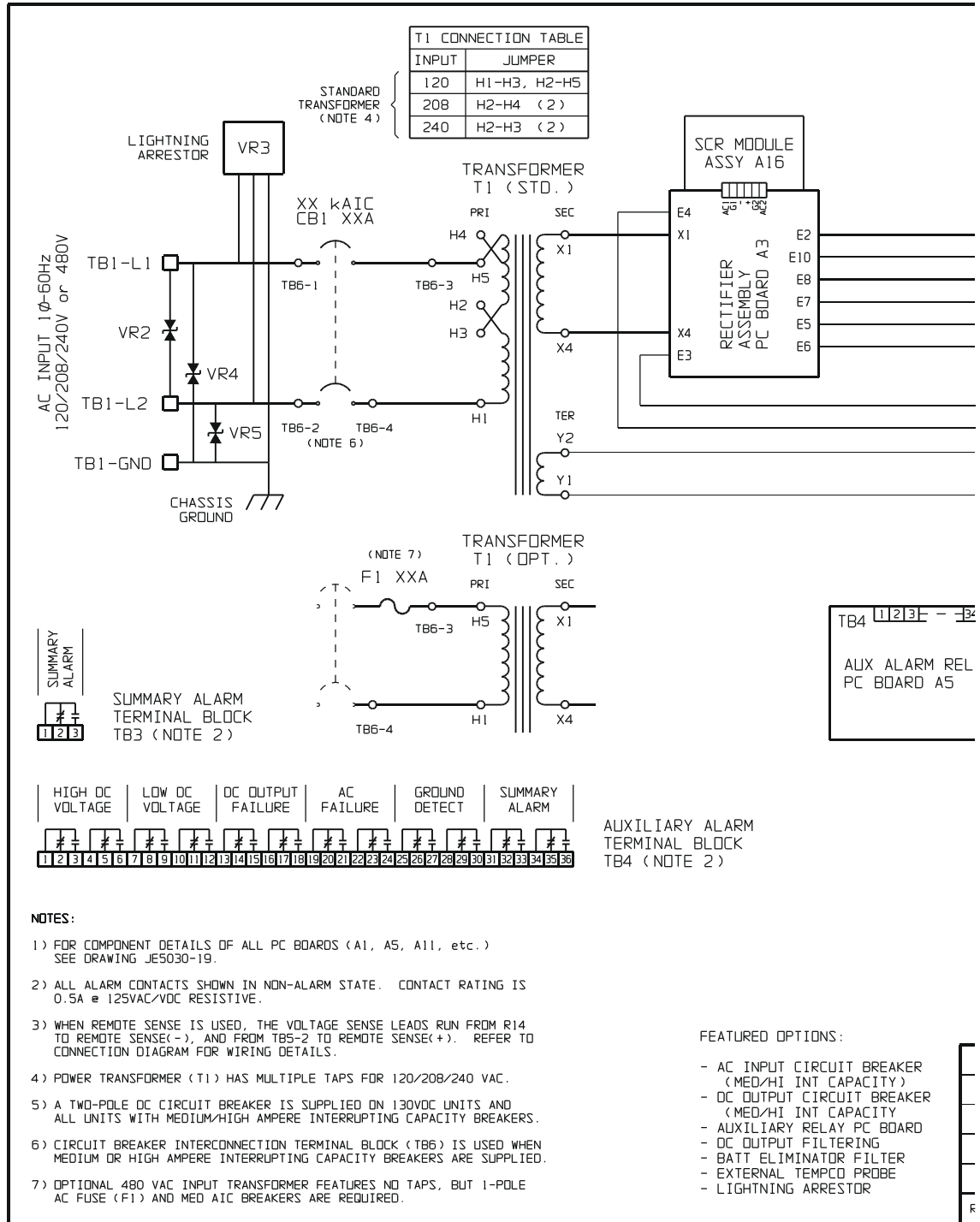

Note: Online standard drawings, saved in **Adobe Acrobat** Portable Document Format (**PDF**), for the AT10.1 Series Battery Charger are available for downloading and printing. Please contact your sales representative for document availability or see the manufacturer's web site listed on the back cover of this manual.

APPENDIX C (Standard Drawings)

Schematic - AT10.1 Group I Battery Charger with Common Options (JE5031-99)

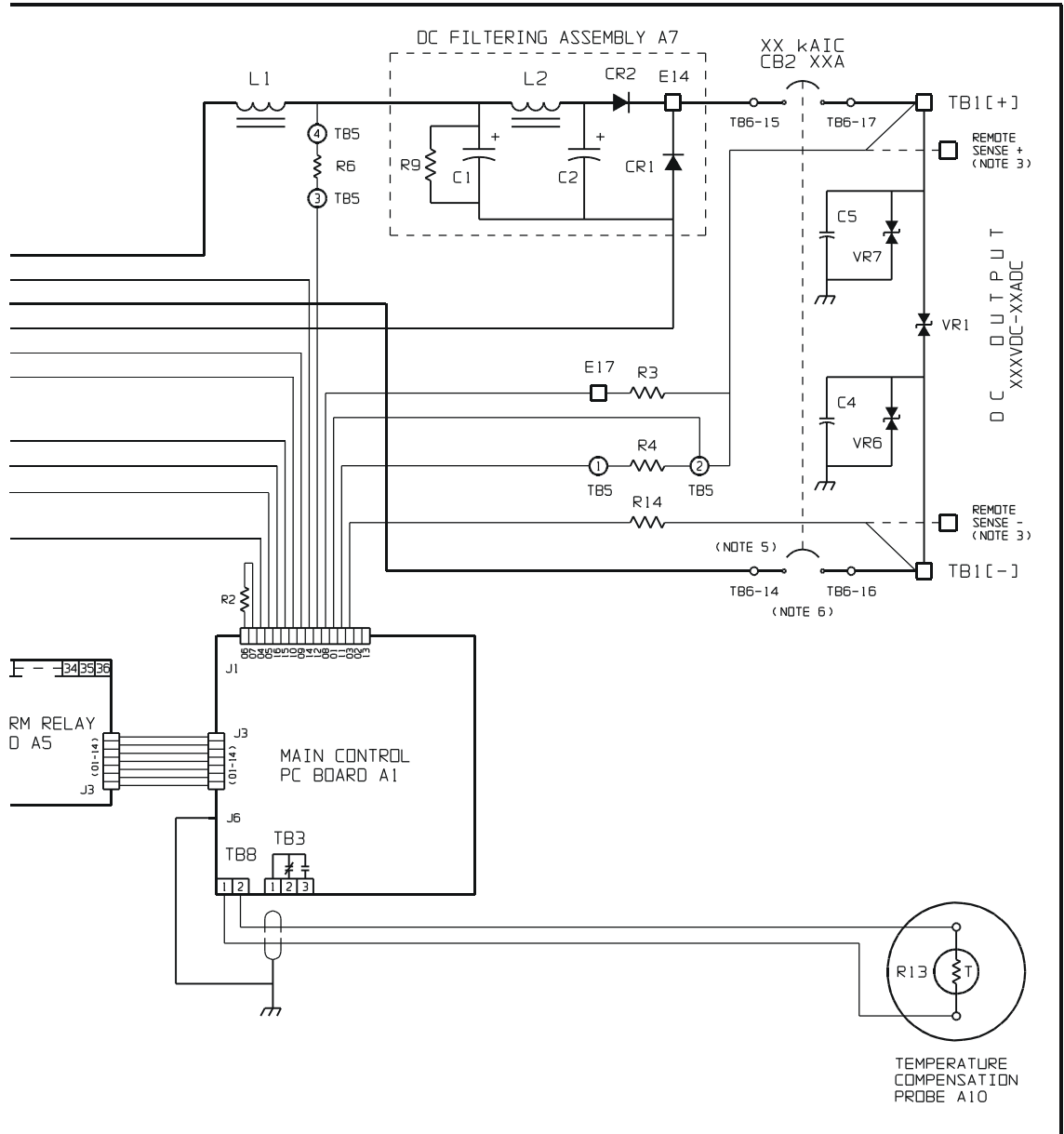

R ER D					THIRD ANGLE PROJECTION	TITLE AT10.1 SERIES BATTERY CHARGER: SCHEMATIC: 6-25ADC (GROUP I) W/COMMON OPTIONS			
	2	E1742	091004		DRAWN BY MCR	022003	DRAWING No JE5031-99		
	1	E1203	040703	OK	APPROVED OK	022003	REV 2	B	
	0	E1142	022003	OK	UNLESS OTHERWISE NOTED DIMENSIONS ARE IN INCHES. TOLERANCES ARE:				
REV	ECN No	DATE	APP	SCALE NTS			PART No JE5031-99	SHEET 1 OF 1	

APPENDIX C (Standard Drawings)

Connection Diagram - AT10.1 Group I Battery Charger Standard w/o Options (JE5033-00)

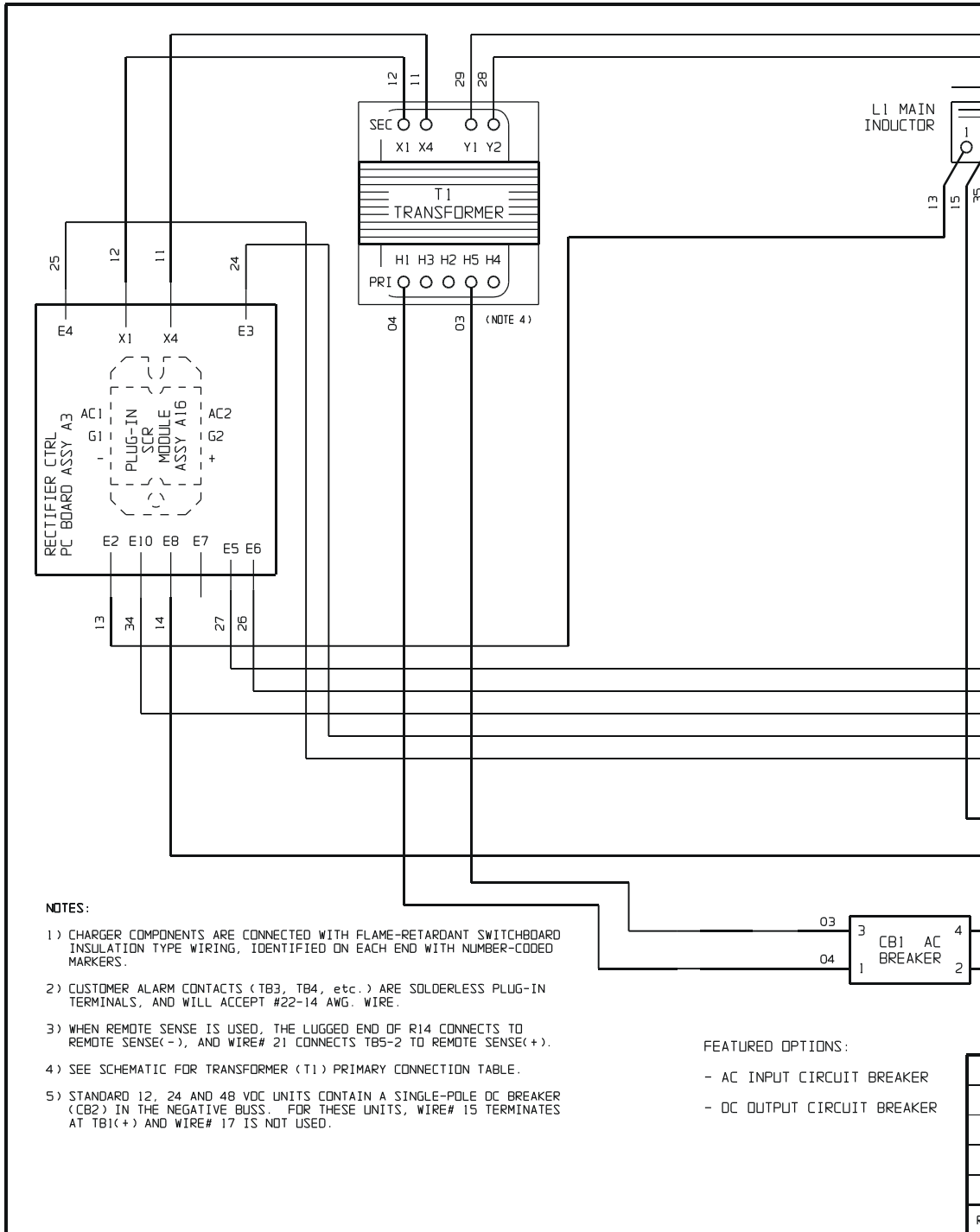

Note: Online standard drawings, saved in **Adobe Acrobat** Portable Document Format (**PDF**), for the AT10.1 Series Battery Charger are available for downloading and printing. Please contact your sales representative for document availability or see the manufacturer's web site listed on the back cover of this manual.

APPENDIX C (Standard Drawings)

Connection Diagram - AT10.1 Group I Battery Charger Standard w/o Options (JE5033-00)

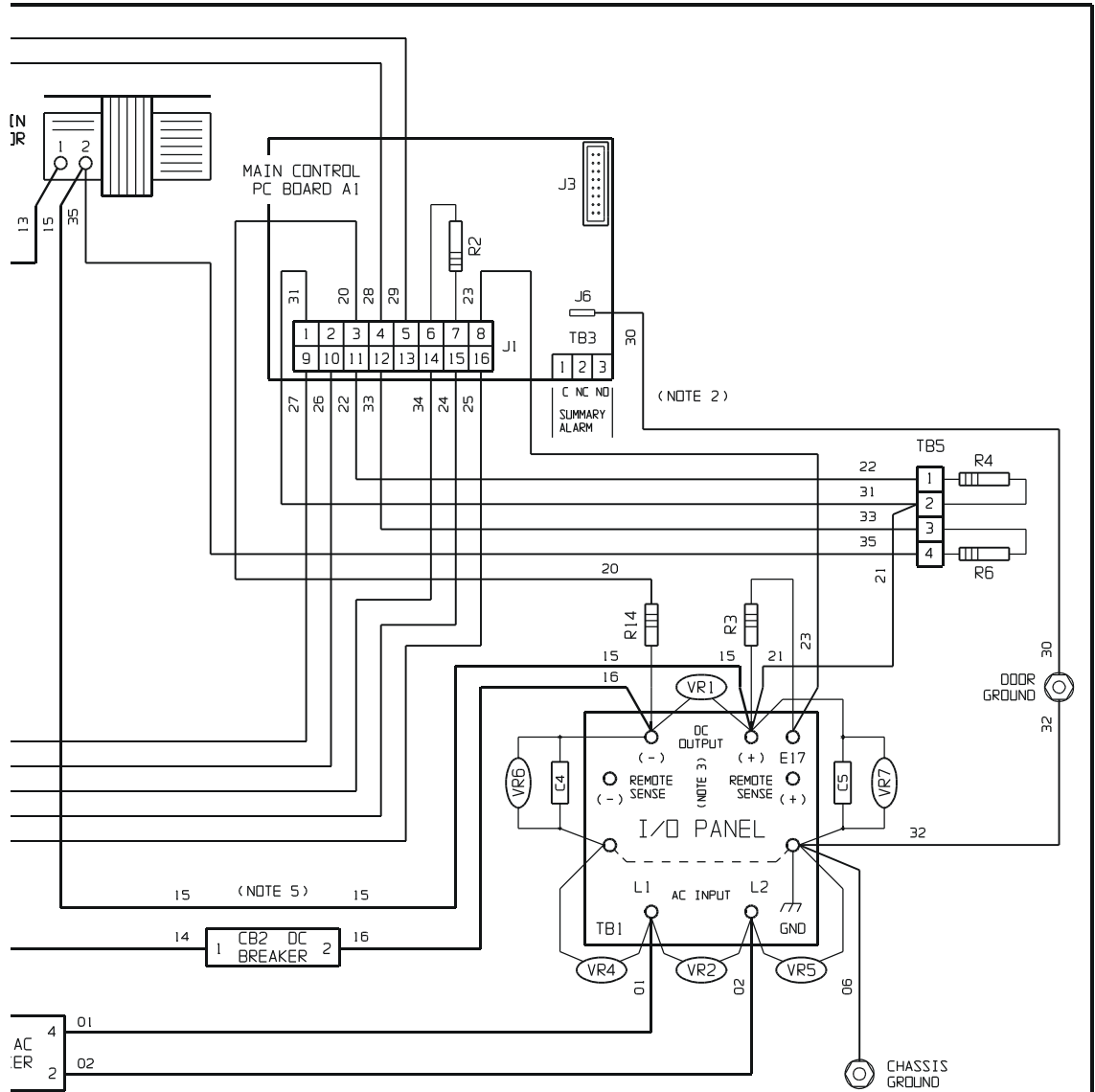

R ER					 THIRD ANGLE PROJECTION			
			DRAWN BY MCR 040703		TITLE AT10.1 SERIES BATTERY CHARGER: CONN DIAG: 6-25ADC (GROUP I) STD - W/O OPTIONS			
	1 E1742 091004		APPROVED <i>[Signature]</i> 040703		DRAWING No JE5033-00		REV 1	B
	0 E1204 040703		UNLESS OTHERWISE NOTED DIMENSIONS ARE IN INCHES. TOLERANCES ARE:		SCALE NTS		PART No JE5033-00	SHEET 1 OF 1
	REV	ECN No			DATE	APP		

APPENDIX C (Standard Drawings)

Connection Diagram - AT10.1 Group I Battery Charger with Common Options (JE5033-99)

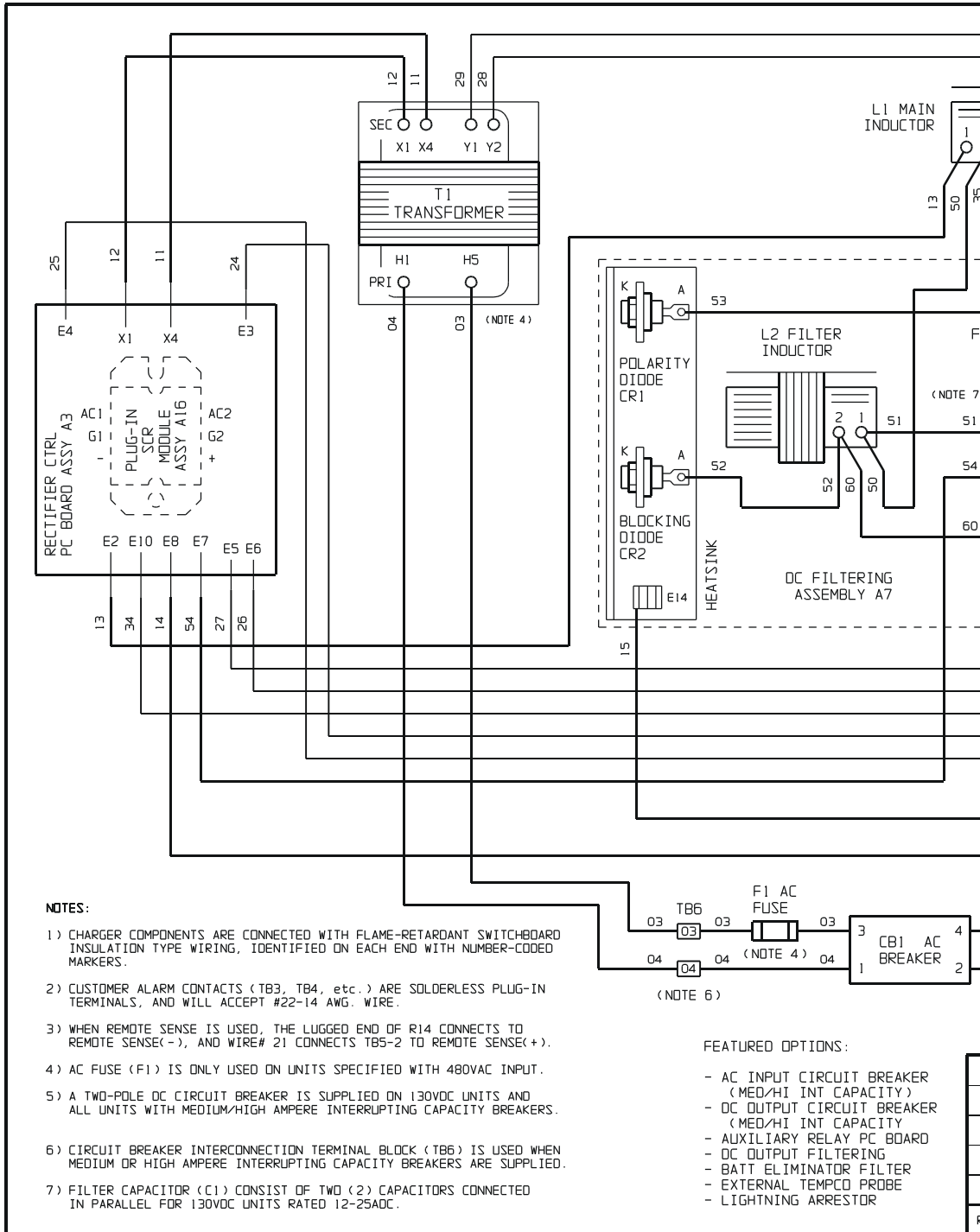

Note: Online standard drawings, saved in **Adobe Acrobat** Portable Document Format (**PDF**), for the AT10.1 Series Battery Charger are available for downloading and printing. Please contact your sales representative for document availability or see the manufacturer's web site listed on the back cover of this manual.

APPENDIX C (Standard Drawings)

Connection Diagram - AT10.1 Group I Battery Charger with Common Options (JE5033-99)

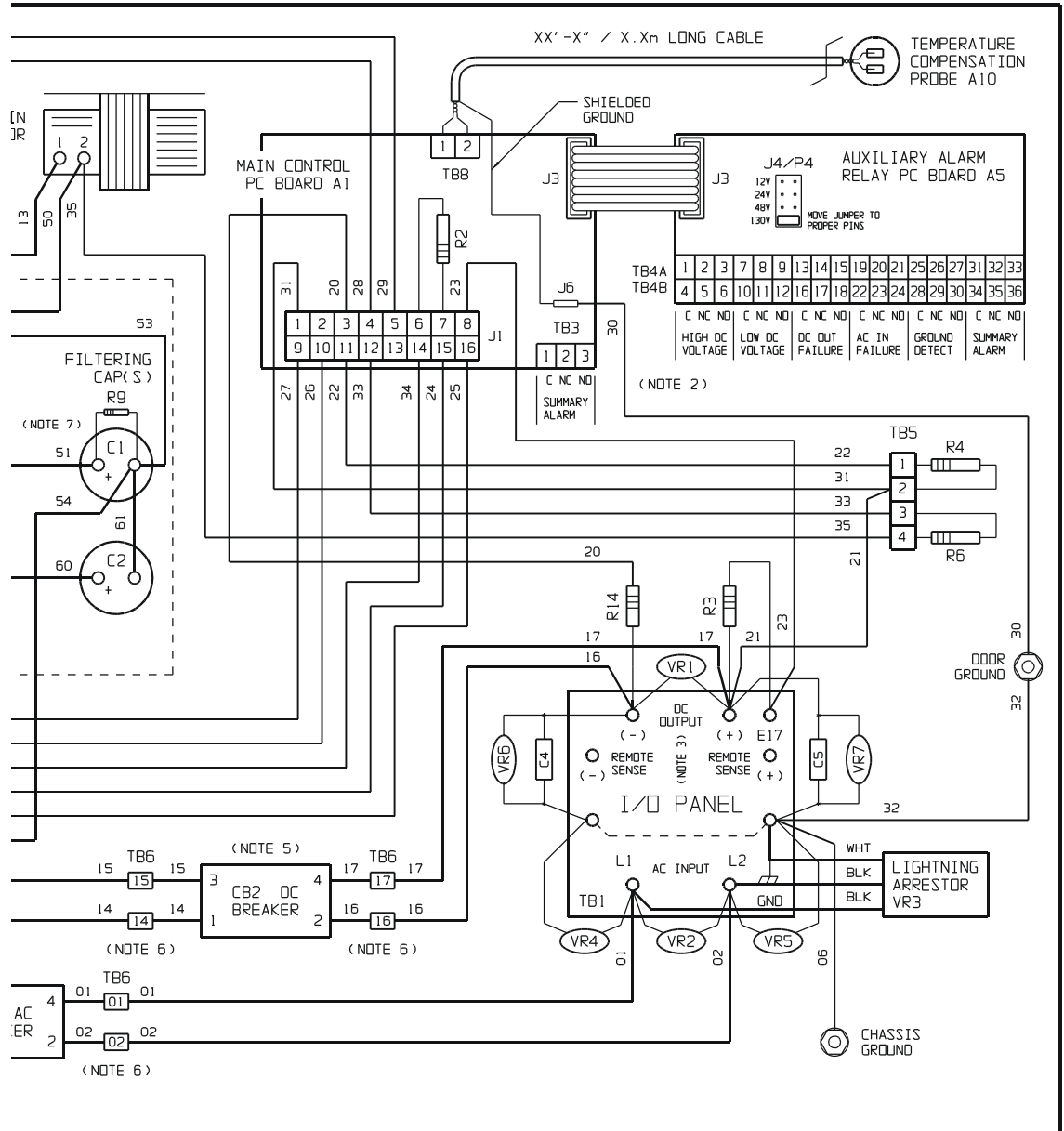

R E R D				THIRDO ANGLE PROJECTION			
				DRAWN BY MCR 040703	TITLE AT10.1 SERIES BATTERY CHARGER: CONN DIAG: 6-25ADC (GROUP I) W/COMMON OPTIONS		
				APPROVED <i>[Signature]</i> 040703			
	1	E1742	091004	DRAWING No JE5033-99 REV 1 B			
	0	E1204	040703				
REV	ECN No	DATE	APP	SCALE NTS PART No JE5033-99		SHEET 1 OF 1	

APPENDIX D

RECOMMENDED FLOAT AND EQUALIZE VOLTAGES

This table contains suggested values for commonly used batteries. Consult your battery manufacturer's documentation for specific values and settings for your battery type.

Battery Cell Type		Recommended Float Voltage/cell	Recommended Equalize Voltage/cell
Lead-Acid Types	Antimony 1.215 Sp. Gr.	2.17	2.33
	Antimony 1.250 Sp. Gr.	2.20	2.33
	Calcium 1.215 Sp. Gr.	2.25	2.33
	Calcium 1.250 Sp. Gr.	2.29	2.33
	Absorbed / Gelled Electrolyte * (sealed Lead-Acid type)	2.25	*
Nickel Cadmium		1.42	1.47

* Sealed Lead-Acid battery types should not be used in ambient temperatures above 95° F / 35° C, and should not normally be equalized. Please consult your battery manufacturer's documentation for specific equalizing recommendations.

TEMPERATURE COMPENSATION

If batteries are to see temperature variations during charging, a temperature compensation option (A10) is recommended. If this option is not part of your charger, manual adjustments should be made. Please refer to the equation and table below for temperature-adjusted voltages.

$$\text{temperature-adjusted voltage} = \text{charge voltage} \times K$$

Temperature (°F)	Temperature (°C)	K (Lead Acid)	K (Nickel Cadmium)
35	1.7	1.058	1.044
45	7.2	1.044	1.034
55	12.8	1.031	1.023
65	18.3	1.017	1.013
75	23.9	1.003	1.002
77	25.0	1.000	1.000
85	29.4	0.989	0.992
95	35.0	0.975	0.981
105	40.6	0.961	0.970

COMMUNICATIONS MODULE

Your AT10.1 Battery Charger has provisions for an optional Communications Module that allows the user to remotely monitor and control the charger over a serial connection. This PC Board Assembly (A12) supports DNP3 Level 2 and Modbus protocols over RS-232 or RS-485 half-duplex. The system can be used with a modem for telephone communications. All features of the AT10.1's front instrument panel are accessible remotely, using this option. SCADA (Supervisory Control And Data Acquisition) systems will be able to control, monitor and log the events of the battery charger.

The standard Communications Module kit (**EJ5037-XX**) includes the Communications PC Board (A12), an external power supply assembly (A14), a separate AT Series Communications Module Operations Manual (**JA5026-00**), and field-retrofit instructions. The Communications Module Operations Manual, along with a sales catalog cut sheet, is freely available for download from the web site featured on the back cover of this manual. A compatible industry-standard modem and modem cable are also available. Contact your sales representative to place an order for the AT Series Battery Charger Communication Module. Refer to the table below for ordering information.

Description	Part No.
Communications Module for 12 Vdc AT10.1	EJ5037-01
Communications Module for 24 Vdc AT10.1	EJ5037-02
Communications Module for 48 Vdc AT10.1	EJ5037-03
Communications Module for 130 Vdc AT10.1	EJ5037-04
Compatible Modem Option	PM5005-00
10ft / 3.05m Modem Cable	EH5026-00
25ft / 7.62m Modem Cable	EH5026-01
50ft / 15.24m Modem Cable	EH5026-02

UL DATA

CAUTION				
To operate this charger from inputs other than 120 Vac, you must use branch circuit protection. To reduce the risk of fire, use only on circuits provided with the following branch circuit protection in accordance with the National Electrical Code, ANSI/NFPA 70.				
Current Rating	Charger Voltage Rating			
	48 Vdc	130 Vdc	48 Vdc	130 Vdc
12 Adc	---	25A	---	20A
16 Adc	15A	25A	12A	20A
20 Adc	20A	30A	15A	30A
25 Adc	25A	40A	20A	35A
208 Vac Branch Circuit Protection (Amperes)			240 Vac Branch Circuit Protection (Amperes)	

NOTE: This table does not apply to AT10.1 chargers with 480 Vac input.

CUSTOMER NOTES

MANUAL REVISION:

The text and graphics contained within this manual are controlled by the battery charger manufacturer's internal part number (**JA5023-00**). The revision level of this manual's text and graphics are featured in the electronic filename listed below. The revision dates are also listed below and supercede all other available dates. The first two and last two pages of this manual are reserved for company-specific front and back cover artwork. Any revision levels, revision dates or document numbers featured on the first two and last two pages of this manual refer to the cover artwork only.

DOCUMENT INFORMATION:

Document Number:	JA5023-00
Revision Level:	2
Document Change Number:	E1741
Filename	[JA5023-00.Rev.2.AT10.1.Group-1.Manual.doc]
Last Date Saved	[9/16/2004 10:24 AM]
Last Date Printed	[9/16/2004 10:24 AM]

DRAWINGS:

Any job-specific custom drawings supplied with this battery charger and/or this manual, supercede the standard drawings featured in Appendix C. The standard drawings and corresponding page numbers featured in this section may not be included with custom printed manuals, when job-specific custom drawings are supplied.

ON-LINE AVAILABILITY:

Electronic versions of this manual and/or any custom or standard drawings for the AT10.1 Series Battery Charger are available online. Saved in Adobe Acrobat Portable Document Format (PDF), they are readily available for downloading and printing. Please contact your sales representative for document availability or see the manufacturer's web site listed on the back cover of this manual.

QUICK OPERATION

For unpacking and installation instructions, see section 1 on page 2 in this manual

To learn how to use the equalize timers, see sections 2.2.4 on page 27 and 2.3.3 on page 32

For details on setting parameters, see section 2.3 starting on page 30

If you don't press any key for 25 seconds, the AT10.1 resumes normal operation automatically

Startup





- ▶ Turn on the dc breaker, labeled “**DC OUTPUT**”.
- ▶ Turn on the ac breaker, labeled “**AC INPUT**”.

Changing between Float and Equalize Modes

- ▶ Press the  key to toggle from Float mode to Equalize mode. Press again to toggle back to Float. The green or yellow indicator identifies the current mode.

Setting

Float Voltage
Equalize Voltage
Equalize Timer
High DC Voltage
Low DC Voltage

- ▶ Press the  key. The **DC VOLTS** and **FLOAT** indicators light, and the digital display flashes the present float voltage setting.
- ▶ Press the  or  key until the digital display indicates the desired float voltage.
- ▶ Press the  key to save the new setting internally.
- ▶ The **EDIT** sequence advances to the equalize voltage as shown by the front panel indicators. Repeat the above steps until you have set all parameters.