



# MODEL W1690 DELUXE CEILING MOUNTED AIR CLEANER



## INSTRUCTION MANUAL

Phone: 1-360-734-3482 • On-Line Technical Support: [tech-support@shopfox.biz](mailto:tech-support@shopfox.biz)

COPYRIGHT © FEBRUARY, 2003 BY WOODSTOCK INTERNATIONAL, INC.  
WARNING: NO PORTION OF THIS MANUAL MAY BE REPRODUCED IN ANY SHAPE OR FORM WITHOUT  
THE WRITTEN APPROVAL OF WOODSTOCK INTERNATIONAL, INC.

Printed in China

# WARNING

Some dust created by power sanding, sawing, grinding, drilling, and other construction activities contains chemicals known to the State of California to cause cancer, birth defects or other reproductive harm. Some examples of these chemicals are:

- Lead from lead-based paints.
- Crystalline silica from bricks, cement, and other masonry products.
- Arsenic and chromium from chemically treated lumber.

Your risk from these exposures varies, depending on how often you do this type of work. To reduce your exposure to these chemicals: work in a well ventilated area, and work with approved safety equipment, such as those dust masks that are specially designed to filter out microscopic particles.

# TABLE OF CONTENTS

	PAGE
INTRODUCTION .....	2
About Your New Deluxe Ceiling Mounted Air Cleaner .....	2
Woodstock Service and Support.....	2
Warranty and Returns .....	3
Specifications .....	3
SAFETY .....	4
Standard Safety Instructions .....	4-5
Additional Safety Instructions for Air Cleaners .....	6
ELECTRICAL .....	7
110V Operation .....	7
Extension Cords.....	7
Grounding .....	7
INSTALLATION .....	8
Unpacking .....	8
Box Contents .....	8
Shop Preparation .....	9
Dust System .....	9
Beginning .....	10
Table-Top Mount .....	10
Hanging Mount.....	11
Flush Mount .....	12
OPERATION .....	13
Overview .....	13
Control Panel .....	13
Remote Control .....	13
Troubleshooting.....	14
MAINTENANCE.....	15
Filters .....	15
CLOSURE .....	16
Parts Breakdown and Parts List .....	17-18

USE THE QUICK GUIDE PAGE LABELS TO SEARCH OUT INFORMATION FAST!





# INTRODUCTION

## About Your New Deluxe Ceiling Mounted Air Cleaner

Your new **SHOP FOX**® Model W1690 Deluxe Ceiling Mounted Air Cleaner has been specially designed to provide many years of trouble-free service. Close attention to detail, ruggedly built parts and a rigid quality control program assure safe and reliable operation.

When used in conjunction with a dust collector system, the W1690 Deluxe Ceiling Mounted Air Cleaner efficiently removes fine wood particles in the air that many dust collectors cannot. Your unit has key features like a 5-micron outer filter, a washable 1-micron inner filter, three fan speeds, 110V operation, remote control functions, and a compact design. For further features and details, refer to the **Specifications** section on **Page 3**.

Woodstock International, Inc. is committed to customer satisfaction in providing this manual. It is our intent to include all the information necessary for safety, ease of assembly, practical use and durability of this product.

If you need the latest edition of this manual, you can download it from <http://www.shopfox.biz>.  
If you still have questions after reading the latest manual, or if you have comments please contact us at:

**Woodstock International, Inc.**  
**Attn: Technical Support Department**  
**P.O. Box 2309**  
**Bellingham, WA 98227**

## Woodstock Service and Support

We stand behind our machines! In the event that a defect is found, parts are missing or questions arise about your machine, please contact Woodstock International Service and Support at 1-360-734-3482 or send e-mail to: [tech-support@shopfox.biz](mailto:tech-support@shopfox.biz). Our knowledgeable staff will help you troubleshoot problems, order parts or arrange warranty returns.

# Warranty and Returns

Woodstock International, Inc. warrants all **SHOP FOX**® machinery to be free of defects from workmanship and materials for a period of 2 years from the date of original purchase by the original owner. This warranty does not apply to defects due directly or indirectly to misuse, abuse, negligence or accidents, lack of maintenance, or to repairs or alterations made or specifically authorized by anyone other than Woodstock International, Inc.

Woodstock International, Inc. will repair or replace, at its expense and at its option, the **SHOP FOX**® machine or machine part which in normal use has proven to be defective, provided that the original owner returns the product prepaid to the **SHOP FOX**® factory service center or authorized repair facility designated by our Bellingham, WA office, with proof of their purchase of the product within 2 years, and provides Woodstock International, Inc. reasonable opportunity to verify the alleged defect through inspection. If it is determined there is no defect, or that the defect resulted from causes not within the scope of Woodstock International Inc.'s warranty, then the original owner must bear the cost of storing and returning the product.

This is Woodstock International, Inc.'s sole written warranty and any and all warranties that may be implied by law, including any merchantability or fitness, for any particular purpose, are hereby limited to the duration of this written warranty. We do not warrant that **SHOP FOX**® machinery complies with the provisions of any law or acts. In no event shall Woodstock International, Inc.'s liability under this warranty exceed the purchase price paid for the product, and any legal actions brought against Woodstock International, Inc. shall be tried in the State of Washington, County of Whatcom. We shall in no event be liable for death, injuries to persons or property or for incidental, contingent, special or consequential damages arising from the use of our products.

Every effort has been made to ensure that all **SHOP FOX**® machinery meets high quality and durability standards. We reserve the right to change specifications at any time because of our commitment to continuously improve the quality of our products.

## Specifications

Motor .....	1/5 HP, 115V, 60 Hz, 1200 RPM, Single-Phase
Motor Amperage.....	HI = 3 Amps, MID = 2 1/2 Amps, LO = 2 Amps
Motor Low Speed .....	750 RPM
Motor Medium Speed .....	960 RPM
Motor High Speed .....	1200 RPM
Fan Low Speed Sound Rating .....	62 dB
Fan Medium Speed Sound Rating.....	67 dB
Fan High Speed Sound Rating.....	69 dB
Air Flow at Low Speed .....	556 CFM
Air Flow at Medium Speed.....	702 CFM
Air Flow at High Speed .....	1044 CFM
Primary Filter .....	5-Micron
Secondary Filter.....	1-Micron
Unit Dimensions (L x W x H) .....	30 1/4" x 24 1/8" x 12 1/8"
Shipping Weight .....	64 lbs.
Installed Weight .....	55 lbs.

# SAFETY

**READ MANUAL BEFORE OPERATING MACHINE.  
FAILURE TO FOLLOW INSTRUCTIONS BELOW WILL  
RESULT IN PERSONAL INJURY.**



Indicates an imminently hazardous situation which, if not avoided, **WILL** result in death or serious injury.



Indicates a potentially hazardous situation which, if not avoided, **COULD** result in death or serious injury.



Indicates a potentially hazardous situation which, if not avoided, **MAY** result in minor or moderate injury.

## NOTICE

This symbol is used to alert the user to useful information about proper operation of the equipment, and/or a situation that may cause damage to the machinery.

## Standard Safety Instructions

1. **Thoroughly read the instruction manual before operating your machine.** Learn the applications, limitations and potential hazards of this machine. Keep manual in a safe, convenient place for future reference.
2. **Keep work area clean and well lit.** Clutter and inadequate lighting invite potential hazards.
3. **Ground all tools.** If a machine is equipped with a three-prong plug, it must be plugged into a three-hole grounded electrical receptacle or grounded extension cord. If using an adapter to aid in accommodating a two-hole receptacle, ground using a screw to a known ground.
4. **Wear eye protection at all times.** Use safety glasses with side shields or safety goggles that meet the appropriate standards of the American National Standards Institute (ANSI).
5. **Avoid dangerous environments.** DO NOT operate this machine in wet or open flame environments. Airborne dust particles could cause an explosion and severe fire hazard.
6. **Ensure all guards are securely in place and in working condition.**
7. **Make sure the machine power switch is in the OFF position** before connecting power to machine.
8. **Keep the work area clean, free of clutter, grease, etc.**
9. **Keep children and visitors away.** Visitors should be kept at a safe distance while operating unit.
10. **Childproof your workshop** with padlocks, master switches or by removing starter keys.
11. **Stop and disconnect the machine when cleaning, adjusting or servicing.**

- 12. **DO NOT force tool.** The machine will do a safer and better job at the rate for which it was designed.
- 13. **Use correct tool.** Do not force machine or attachment to do a job for which it was not designed.
- 14. **Wear proper apparel.** Do not wear loose clothing, neck ties, gloves, jewelry, and secure long hair away from moving parts.
- 15. **Remove adjusting keys, rags, and tools.** Before turning the machine on, make it a habit to check that all adjusting keys and wrenches have been removed.

16. **Avoid using an extension cord.** But if you must, examine the extension cord to ensure it is in good condition. Use TABLE 1 to determine the correct length and gauge of extension cord needed for your particular needs. The amp rating of the motor can be found on its nameplate. If the motor is dual voltage, be sure to use the amp rating for the voltage you will be using. If you use an extension cord with an undersized gauge or one that is too long, excessive heat will be generated within the circuit, increasing the chance of a fire or damage to the circuit. Always use an extension cord that uses a ground pin and connected ground wire. Immediately replace a damaged extension cord.

**Extension Cord Requirements**  
TABLE 1

Amp Rating	Length and Gauge		
	25ft	50ft	100ft
0-6	#16	#16	#16
7-10	#16	#16	#14
11-12	#16	#16	#14
13-16	#14	#12	#12
17-20	#12	#12	#10
21-30	#10	#10	No

- 17. **Keep proper footing and balance** at all times.
- 18. **DO NOT leave machine unattended.** Wait until it comes to a complete stop before leaving the area.
- 19. **Perform machine maintenance and care.** Follow lubrication and accessory attachment instructions in the manual.
- 20. **Keep machine away from open flame.** Operating machines near pilot lights and/or open flames creates a high risk if dust is dispersed in the area. Dust particles and an ignition source may cause an explosion. Do not operate the machine in high-risk areas, including but not limited to, those mentioned above.
- 21. **If at any time you are experiencing difficulties** performing the intended operation, stop using the machine! Contact our service department or ask a qualified expert how the operation should be performed.
- 22. **Habits—good and bad—are hard to break.** Develop good habits in your shop and safety will become second-nature to you.

**⚠ WARNING**

Always wear safety glasses or goggles when operating equipment. Operating this equipment creates the potential for flying debris that can cause eye injury. Everyday glasses or reading glasses only have impact resistant lenses, they are not safety glasses. Be certain the safety glasses you wear meet the appropriate standards of the American National Standards Institute (ANSI).





# Additional Safety Instructions for Air Cleaners

 <p>SHOP FOX MODEL W1690 DELUXE CEILING MOUNTED AIR CLEANER INSTRUCTION MANUAL</p>	<p><b>⚠ WARNING</b></p> <p>Read and understand this entire instruction manual before using this machine. Serious personal injury may occur if safety and operational information is not understood and followed. Do not risk your safety by not reading!</p>
---	--

<p><b>⚠ CAUTION</b></p> <p>Use this and other machinery with caution and respect, and always consider safety first, as it applies to your individual working conditions. Remember, no list of safety guidelines can be complete, and every shop environment is different. Failure to follow guidelines can result in serious personal injury, damage to equipment and/or poor work results.</p>
---

- **ALWAYS** secure any aprons, clothing, and long hair away from the intake side of the air cleaner unit and any moving parts.
- **ALWAYS** research the dangers of the specific species of wood you are working with as dust from some woods are toxic and can make you sick, cause cancer, and lead to long-term respiratory problems.
- **ALWAYS** use a respirator along with a dust collection system when operating woodworking machinery, and keep the filters of your air cleaner unit clean for optimum performance.
- **ALWAYS** keep your hands and tools away from the fan output screen during fan operation.
- **ALWAYS** turn the air cleaner **OFF**, let the fan and motor come to a complete stop, and unplug the power source before leaving, servicing, adjusting, or troubleshooting the unit.
- **ALWAYS** keep the filters serviced, and never attempt to replace filters or work on the machine while it is operating.
- **ONLY** operate this air cleaner unit in dry environments.
- **NEVER** allow this air cleaner unit to operate in an environment that has volatile fumes from fuels, paints, pesticides, chemicals, smoke; and never operate in an environment that has particles of silica, metal, asbestos, or hazardous bacterium. This air cleaner unit is only designed to remove very fine wood particles from the air. It is not a dust collector.



# ELECTRICAL

## 110V Operation

The **SHOP FOX®** Model W1690 Deluxe Ceiling Mounted Air Cleaner uses a 110V, single-phase, 1/5 HP motor that draws approximately 3 amps at the high speed setting.

Make sure the supply circuit, circuit breaker, or fuse can carry the additional 3 amp load since other machines may be using the same circuit. If the total amperage load of all machines and the air cleaner unit exceeds the amperage rating of the circuit breaker or fuse, use a different circuit that can carry the load.

DO NOT modify an existing low-amperage circuit by only replacing the circuit breaker with a breaker rated for a higher amperage. The breaker and the complete circuit must be replaced by a qualified electrician.

## Extension Cords

We do not recommend using an extension cord with most equipment because the cord can generate heat that may cause fire or circuit damage. If you must use an extension cord, use the guidelines below.

- Use a cord rated for Standard Service (Grade S)
- Use a cord that is 100 feet or less only
- Use a cord with a ground pin
- Use an undamaged cord only

## Grounding

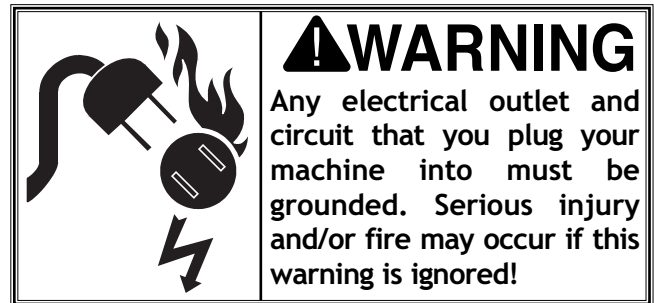

Ground this machine! The electrical cord supplied with the Model W1690 Air Cleaner has a ground pin. If your power receptacle does not have a ground pin hole, have the receptacle replaced by a qualified electrician, or have an appropriate adapter installed and grounded properly.

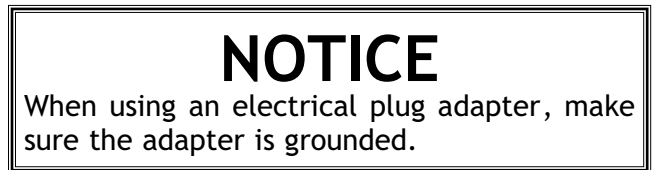

NEVER cut the ground pin off so your air cleaner unit will plug into a non-grounded receptacle. See **Figure 1**. Remember, an adapter with a grounding wire does not guarantee the air cleaner unit is grounded. A ground source must always be verified in the electrical circuit within the wall or conduit.

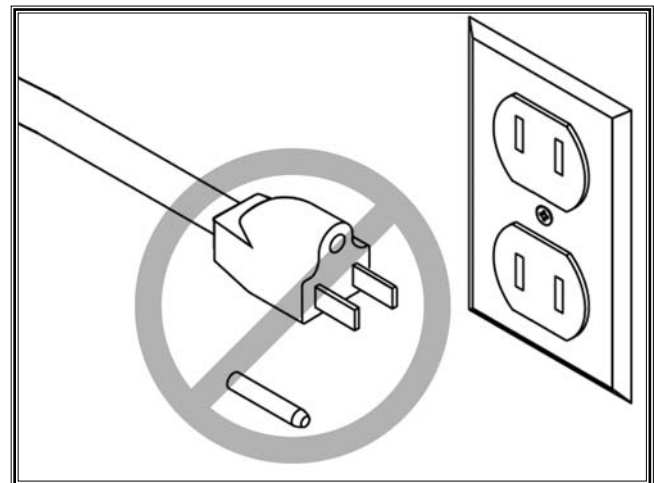

**Figure 1.** NEVER cut the ground pin off so the plug can fit into a non-grounded receptacle.

**ELECTRICAL**

# INSTALLATION

## Unpacking



**⚠ CAUTION**  
Get lifting assistance to remove the unit from the box. At 55 pounds, the Model W1690 Air Cleaner is a heavy load.

The Model W1690 Deluxe Ceiling Mounted Air Cleaner is carefully packed. However, if it is damaged or is missing any parts, please contact Woodstock International Service and Support at 1-360-734-3482 or send e-mail to: [tech-support@shopfox.biz](mailto:tech-support@shopfox.biz).

No assembly is required for the Model W1690 Deluxe Ceiling Mounted Air Cleaner; however, you should remove the filters and remove any packing material that may be inside of the unit.

Hardware has been included for various air cleaner mounting applications.

## Box Contents

Layout and inventory the shipped parts to familiarize yourself with your Model W1690 Deluxe Ceiling Mounted Air Cleaner. See Figures 2 and 3. This will help with the installation process.

Item	Qty.
1. W1690 Deluxe Ceiling Mounted Air Cleaner	1
2. Primary Filter (5-Micron, Pleated-Type)	1
3. Secondary Filter (1-Micron, Bag-Type)	1
4. Hand-Held Remote Control Unit	1
5. AAA Battery	2
6. Flange Bracket	4
7. Hex Bolt (M6-1.0 X 8)	8
8. Flat Washer (6 mm)	8
9. Eye Bolt (M6-1.0 x 20)	4
10. Rubber Foot	4

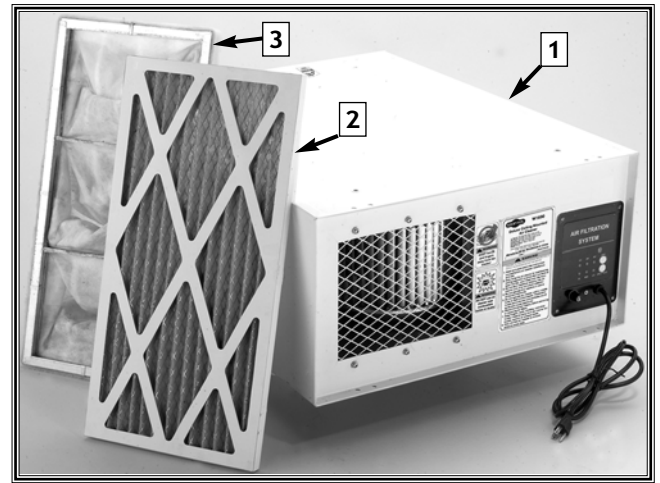

Figure 2. Model W1690 Deluxe Ceiling Mounted Air Cleaner and filters.

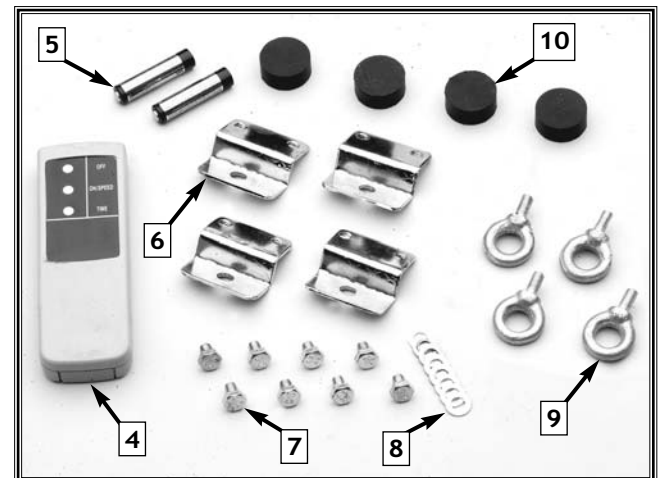



Figure 3. Remote control and mounting hardware.

# Shop Preparation

	<p><b>⚠️ WARNING</b> DO NOT operate this air cleaner unit at a location where flammable fuels, solvents, or other volatile chemicals may exist. Since these products have a low flash point, the fan motor can ignite the fumes and cause an explosion and severe personal injury!</p>
---	--

	<p><b>⚠️ CAUTION</b> DO NOT allow untrained people in your shop! Make sure shop entrances are locked and machines are correctly turned off with lock-out devices when not in use. Otherwise, injury or death can occur.</p>
--	---

- **Machine Mobility:** This air cleaner unit has a balanced fan and uses digital components. Move this air cleaner unit with care, and do not drop or handle it roughly.
- **Operating Location:** Operating this air cleaner unit in the incorrect environment can cause an explosion or respiratory damage to you and others. This air cleaner unit is only designed to help remove very fine wood particles from the air. It is not a dust collector, so take all necessary safety precautions. The operating location must be free of volatile fumes from fuels, paints, pesticides, chemicals, smoke, and other gasses; including an environment free of silica, metal, asbestos, hazardous bacterium, and other particles.

Locate the air cleaner unit where the signal path for the remote control is unobstructed and is used within 75 feet of the control panel. Often, the optimum location for this air cleaner unit is at an overhead central shop location and not at the corners.

- **Working Clearances:** Consider your current and future shop needs with respect to the machinery and the dust collection system used. Make sure that the inlet and the outlet have at least 12" of clearance between obstructions as not to restrict the air flow. The suction must be farther than 3 feet from vents as the filter, if too close to vents, may draw and filter air that is not from your work area. You may have to create or modify other shop ducting to achieve the correct working clearances and airflow.
- **Outlets:** Make sure the electrical circuits have the capacity to handle the amperage requirements of the new air cleaner unit. Refer to **Page 7** for more information. Electrical outlets should be located near the unit so power or extension cords are clear of high-traffic areas.

## Dust System

When used in conjunction with a dust collector system, the Model W1690 Deluxe Ceiling Mounted Air Cleaner efficiently removes most fine wood particles in the air that many dust collectors cannot.

	<p><b>⚠️ CAUTION</b> USE the correct dust collection system in your shop. This air cleaner unit is not a dust collection system and CANNOT be modified as such. Ignoring this warning can result in short and long-term respiratory illness.</p>
--	--

For additional information on the correct dust collection system, additions, or modifications; contact your Woodstock International dealer for a copy of the *Dust Collection Basics* handbook and available accessories.

# Beginning

You can install the air cleaner unit three ways. See **Figures 4** and **5**.

- **Table-Top Mount**, use the rubber feet and/or the flush mount flange brackets for a table-top application. Refer to **Page 10**.
- **Hanging Mount**, use the eye bolts for a high ceiling application. Refer to **Page 11**.
- **Flush Mount**, use the flange brackets for a wall or low ceiling application. Refer to **Page 12**.

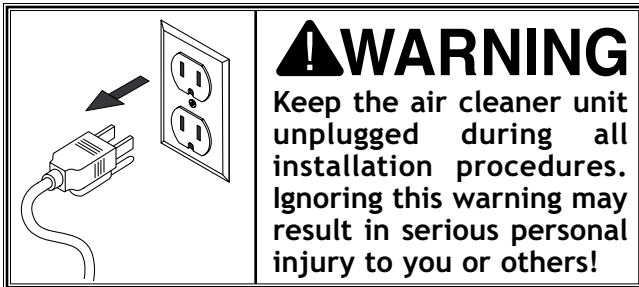

## Table-Top Mount

You can use the air cleaner unit as a portable air filtration system by installing the rubber feet and placing the unit on a workbench or a table.

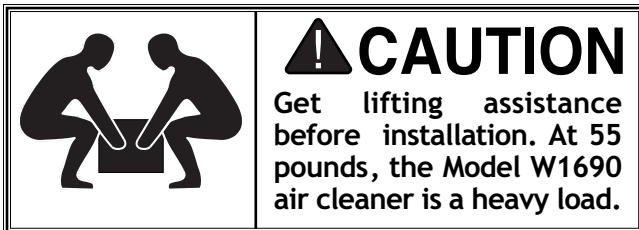

To set up the air cleaner for table-top operation, do these steps:

1. With the help of an assistant, carefully invert the air cleaner unit.
2. Expose the sticky backing on the foot, and affix the rubber foot to the bottom of the air cleaner unit. See **Figure 6**.
3. Repeat **Step 2** for remaining feet.

For permanent table-top mounting, refer to the **Flush Mount** procedure on **Page 12**, and install the air cleaner unit to the tabletop with the flush mount flange brackets.

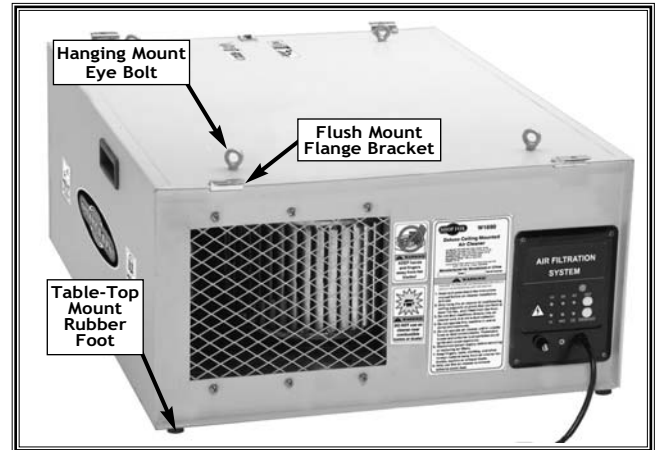

**Figure 4.** Air cleaner unit mounting options.

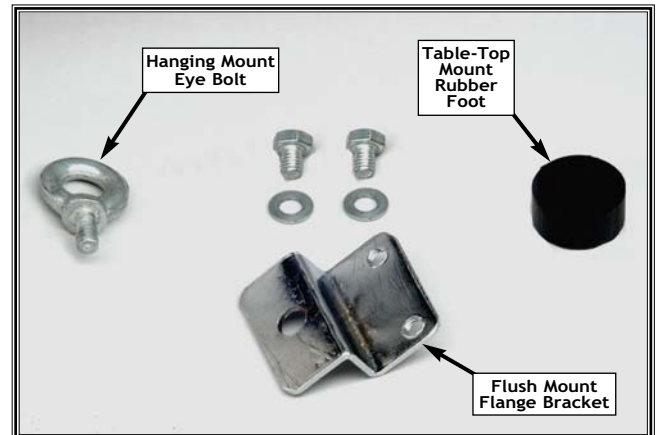

**Figure 5.** Air cleaner unit mounting hardware.

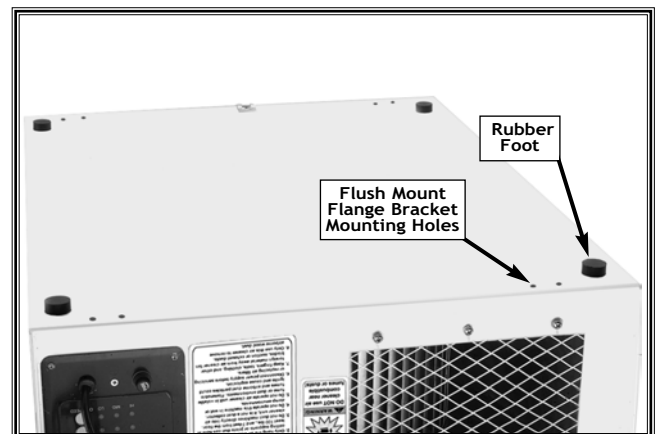

**Figure 6.** Rubber feet correctly installed (Underside View).

# Hanging Mount

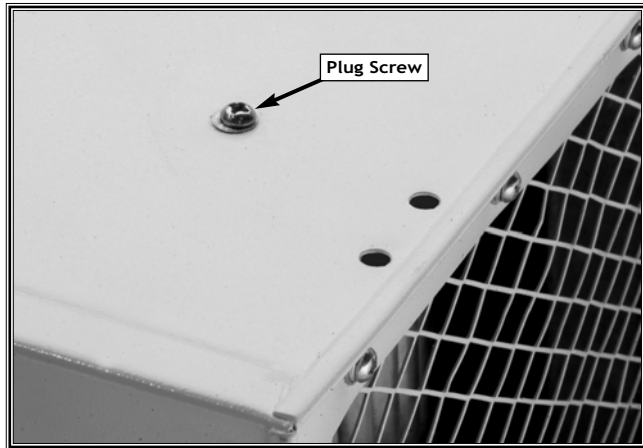

Figure 7. Plug screw.

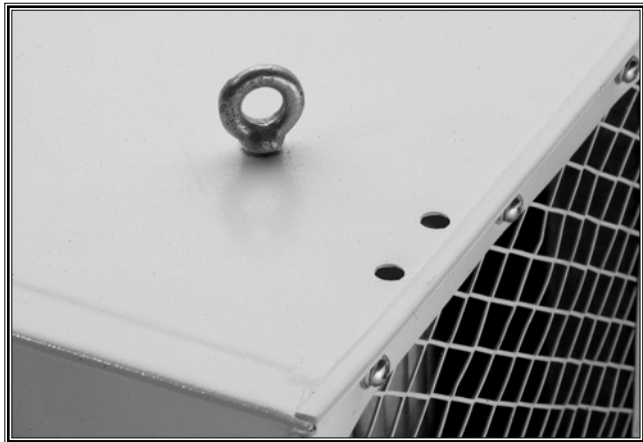

Figure 8. Eye bolt correctly seated.

To make the unit operate at the optimum height of 7 feet from the floor, you can install the air filter unit in your shop by hanging it by chain, cable, or steel strapping.

	<p><b>⚠ CAUTION</b> Get lifting assistance before installation. At 55 pounds, the Model W1690 air cleaner is a heavy load.</p>
--	--

<p><b>⚠ WARNING</b> ONLY hang the air cleaner to load bearing ceiling supports or joists that can hold at least 100 lbs. DO NOT mount the unit to sheet rock, pressboard, paneling, or honeycomb ceiling panels with expansion-type fasteners like the ones shown in Figure 10. The fasteners can tear out and the air cleaner can fall. Ignoring this warning can result in severe injury or death.</p>
--

To install the air cleaner for hanging mount operation, do these steps:

1. Install four chain, cable, or steel strapping lines to your ceiling from capable ceiling studs or supports. When the lines hang down freely they should be 15<sup>1</sup>/<sub>4</sub>" from left-to-right and 24<sup>1</sup>/<sub>2</sub>" from front-to-rear.
2. Remove the plug screw. Retain the screws because if you remove the eye bolts for the flush mounting configuration, you must reinstall these screws to seal the air cleaner unit. See Figure 7.
3. Thread the eye bolt completely into the air filter unit until the jam-nut shoulder contacts the air filter unit. See Figure 8.
4. Tighten the eye bolt until it is snug against the air filter unit.
5. Repeat Steps 2 through 5 on the three remaining eye bolts.
6. Raise and secure the air cleaner eye bolts to the four hanging lines.

INSTALLATION



# Flush Mount

You can install the air filter unit in a confined shop by mounting it flush to a ceiling, wall, or table using the flange mounts.

## ⚠️ WARNING

ONLY mount the air cleaner unit to load bearing supports, wall studs, or table that can hold at least 100 lbs. DO NOT mount the unit to sheet rock walls, pressboard, paneling, or honeycomb wall panels with expansion-type fasteners like the ones shown in Figure 10. The fasteners can tear out and the air cleaner can fall. Ignoring this warning can result in severe injury or death.



## ⚠️ CAUTION

Get lifting assistance before installation. At 55 pounds, the Model W1690 air cleaner is a heavy load.

To install the air cleaner for flush mount operation, do these steps:

1. Locate the applicable load bearing studs or supports in the wall or ceiling, and mark the air cleaner unit bolt pattern on the wall or ceiling (17<sup>1</sup>/<sub>4</sub>" from left-to-right and 31" from front-to-rear).
2. Drill the bolt pattern to accept at least 1/4" shank lag bolts for studs, or use 1/4" nuts, bolts, and washers for mounting to supports.
3. Position the flange bracket under the air cleaner unit lip at the mounting hole location. See Figure 10. For permanent table top mounting, use the lower-lip holes.
4. Install the flat washers and the hex bolts to secure the flange brackets to the unit. See Figure 11.
5. Repeat Steps 3 and 4 for the other three flange brackets.
6. With the help of an assistant, position the air cleaner on the wall or ceiling, and screw or bolt the unit in place.



Figure 9. Typical unacceptable fasteners.

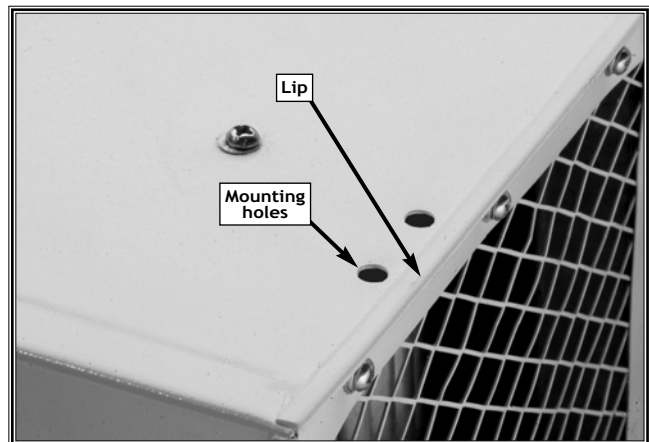

Figure 10. Flange bracket mounting holes and lip.

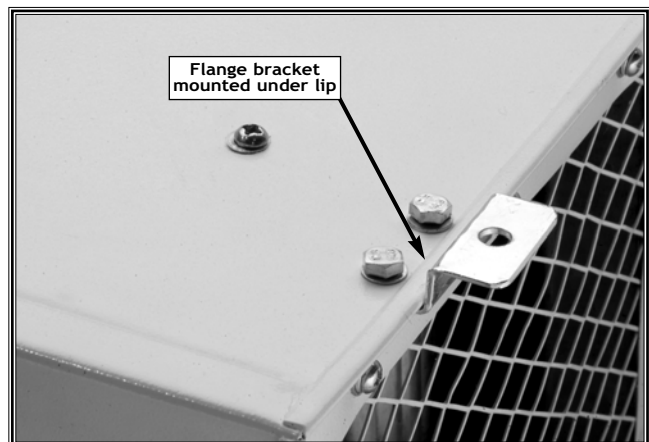

Figure 11. Flange correctly installed under lip.

# OPERATION

## Overview

When the Model W1690 Deluxe Ceiling Mounted Air Cleaner is turned on, the fan motor starts on **HI** and then switches to the speed of your selection. Air is drawn through the primary filter, through the secondary filter, then the cleaned air is distributed into your shop.



Figure 12. Control Panel.

## Control Panel

The control panel enables you to manually turn the air cleaner **ON** and **OFF**, and set the fan speed. The panel has a remote control unit signal receiver, a 5-ampere fuse for circuit protection, and a series of LED lights that indicate your speed and auto shut-off selections. See **Figure 12**.

### NOTICE

ALWAYS take a few moments to listen and observe for unusual noise and vibration after starting the air cleaner.

To operate the air cleaner unit, use the listed controls:

- **OFF:** Allows you to manually turn the air cleaner **OFF**.
- **ON / SPEED:** Allows you to turn the unit **ON** with the first push of the button, and for every additional push, the fan speed is cycled from **LO**, **MID**, and **HI**. Speed selection is indicated by a red LED light.

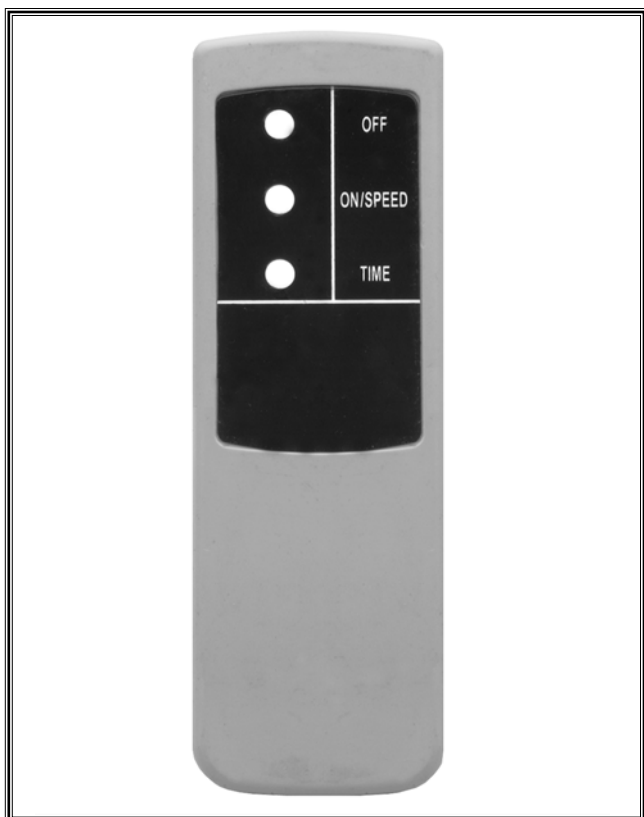

Figure 13. Remote Control.

## Remote Control

The remote control unit enables you to remotely turn the air cleaner **ON** and **OFF**, set the fan speed, and set the auto shut-off time. The remote control unit uses two AAA alkaline batteries as a power source. The remote control unit must be within 75 feet and have an unobstructed infrared signal path to the control panel in order to control the air filter. See **Figure 13**.

To operate the remote control unit, use the listed controls:

- **OFF:** Allows you to remotely shut the air cleaner off.
- **ON / SPEED:** Allows you to remotely turn the unit **ON** with the first push of the button, and for every additional push, the fan speed is cycled from **LO**, **MID**, and **HI**.
- **TIME:** Allows you to set the auto shut-off time from no auto shut-off, to auto shut-off in 1 hour, 2 hours, and 4 hours.

# Troubleshooting

Use this troubleshooting chart to solve any common problems with your Model W1690 Air Cleaner.

SYMPTOM	POSSIBLE REASON	HOW TO REMEDY
The air cleaner does not operate at all.	<p>The power supply circuit breaker is tripped.</p> <p>No power to the control panel.</p> <p>Wiring is at fault.</p> <p>The control panel circuit board is at fault.</p> <p>The motor is at fault.</p>	<p>Correct the cause for high current draw and close the circuit breaker.</p> <p>Replace the blown fuse in the control panel.</p> <p>Repair, replace wires, plugs and cables as applicable; and make sure all electrical plugs and connections are secure.</p> <p>Replace the circuit board.</p> <p>Replace the motor.</p>
The remote control does not operate the air cleaner but the control panel operates fine.	<p>The remote control has no power.</p> <p>The signal path is obstructed.</p> <p>The remote control is at fault.</p> <p>The control panel circuit board is at fault.</p>	<p>Install or replace the batteries.</p> <p>Make sure the signal path is clear to the infrared remote control sensor on the control panel.</p> <p>Replace the hand-held remote control unit.</p> <p>Replace the control panel circuit board.</p>
The air cleaner CFM output is reduced.	<p>The filters are wet or clogged.</p> <p>The airflow path is obstructed.</p> <p>The control panel circuit board is at fault.</p> <p>The motor is at fault.</p>	<p>Replace the primary filter and clean the secondary filter.</p> <p>Remove obstructions or add ducting.</p> <p>Replace the control panel circuit board.</p> <p>Replace the motor.</p>
The air filter unit is noisy or vibrates.	<p>The mounting is loose.</p> <p>The unit is not level.</p> <p>The fan or motor is loose.</p>	<p>Tighten the flange brackets and reinstall the air cleaner unit.</p> <p>Level the air cleaner unit.</p> <p>Unplug the unit, remove the filters, and tighten all loose fasteners.</p>



# MAINTENANCE

## Filters

The amount of use has a direct bearing on when you must change the primary air filter and service the secondary air filter. Contact your **SHOP FOX®** dealer for other possible filter types available.

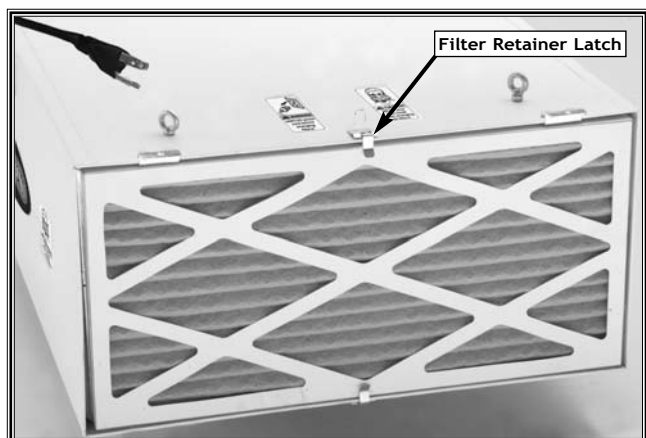

Figure 14. 5-Micron primary filter.

	<p><b>! WARNING</b>          Keep the air cleaner unit unplugged during all maintenance procedures. Ignoring this warning may result in serious personal injury to you or others!</p>
--	---

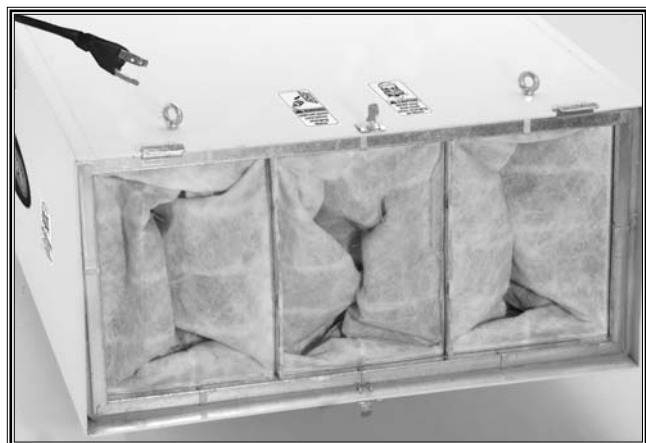

Figure 15. 1-Micron secondary filter.

	<p><b>! WARNING</b>          Always wear a dust mask and safety glasses when servicing and changing filters. Sawdust may cause allergic reactions or respiratory problems.</p>
--	--

To change and service the filters, do these steps:

1. Unplug the air cleaner unit.
2. Move the filter retainer latch upward, remove the primary filter and discard it. See Figure 14.

<p style="text-align: center;"><b>NOTICE</b></p> <p>DO NOT use compressed air to blow out the secondary filter. If you do, you will damage the filter and reduce filtering quality.</p>
---

3. Remove the secondary filter and shake out the wood dust until clean and/or wash out with warm water and let dry. See Figure 15.
4. Vacuum out the inside of the air cleaner housing. See Figure 16.
5. Reinstall the secondary filter when it is dry and install a new primary filter.
6. Move the filter retainer latch downward to lock all the filters in place.

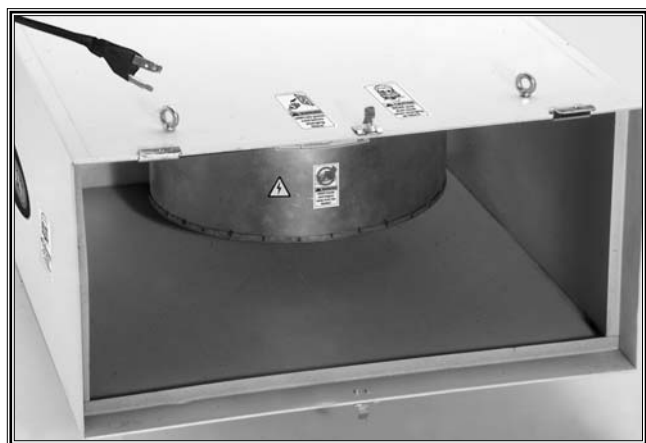

Figure 16. Air cleaner housing.

# CLOSURE

The following pages contain parts diagrams/lists and a warranty card for your **SHOP FOX®** Model W1690.

If you need parts or help in assembling your machine, or if you need more operational information, we encourage you to call our Service Department. Our trained service technicians will be glad to help you.

If you have comments dealing specifically with this manual, please write to us using the address in the General Information. The specifications, drawings, and photographs illustrated in this manual represent the Model W1690 as supplied when the manual was prepared. However, due to Woodstock International, Inc.'s policy of continuous improvement, changes may be made at any time with no obligation on the part of Woodstock International, Inc. Whenever possible, though, we send manual updates to all owners of a particular tool or machine that have registered their purchase with our warranty card. Should you receive one, add the new information to this manual and keep it for reference.

We have included some important safety measures that are essential to the operation of the machine. While most safety measures are generally universal, we remind you that each workshop is different and safety rules should be considered as they apply to your specific situation.

We recommend you keep this manual for complete information regarding Woodstock International, Inc.'s warranty and return policy. Should a problem arise, we recommend that you keep your proof of purchase with your manual. If you need additional technical information relating to this machine, or if you need general assistance or replacement parts, please contact the Service Department at 1-360-734-3482 or e-mail: [tech-support@shopfox.biz](mailto:tech-support@shopfox.biz).

Additional information sources are necessary to realize the full potential of this machine. Trade journals, woodworking magazines, and your local library are good places to start.

The Model W1690 is specifically designed for air filtering operation. **DO NOT MODIFY AND/OR USE THIS MACHINE FOR ANY OTHER PURPOSE. MODIFICATIONS OR IMPROPER USE OF THIS TOOL WILL VOID THE WARRANTY.** If you are confused about any aspect of this machine, **DO NOT** use it until all your questions have been answered.

 <b>WARNING</b>		
<b>Operating this equipment has the potential for flying debris to cause eye injury. Always wear safety glasses or goggles when operating equipment. Everyday glasses or reading glasses only have impact resistant lenses, they are not safety glasses. Be certain the safety glasses you wear meet the appropriate standards of the American National Standards Institute (ANSI).</b>		
		

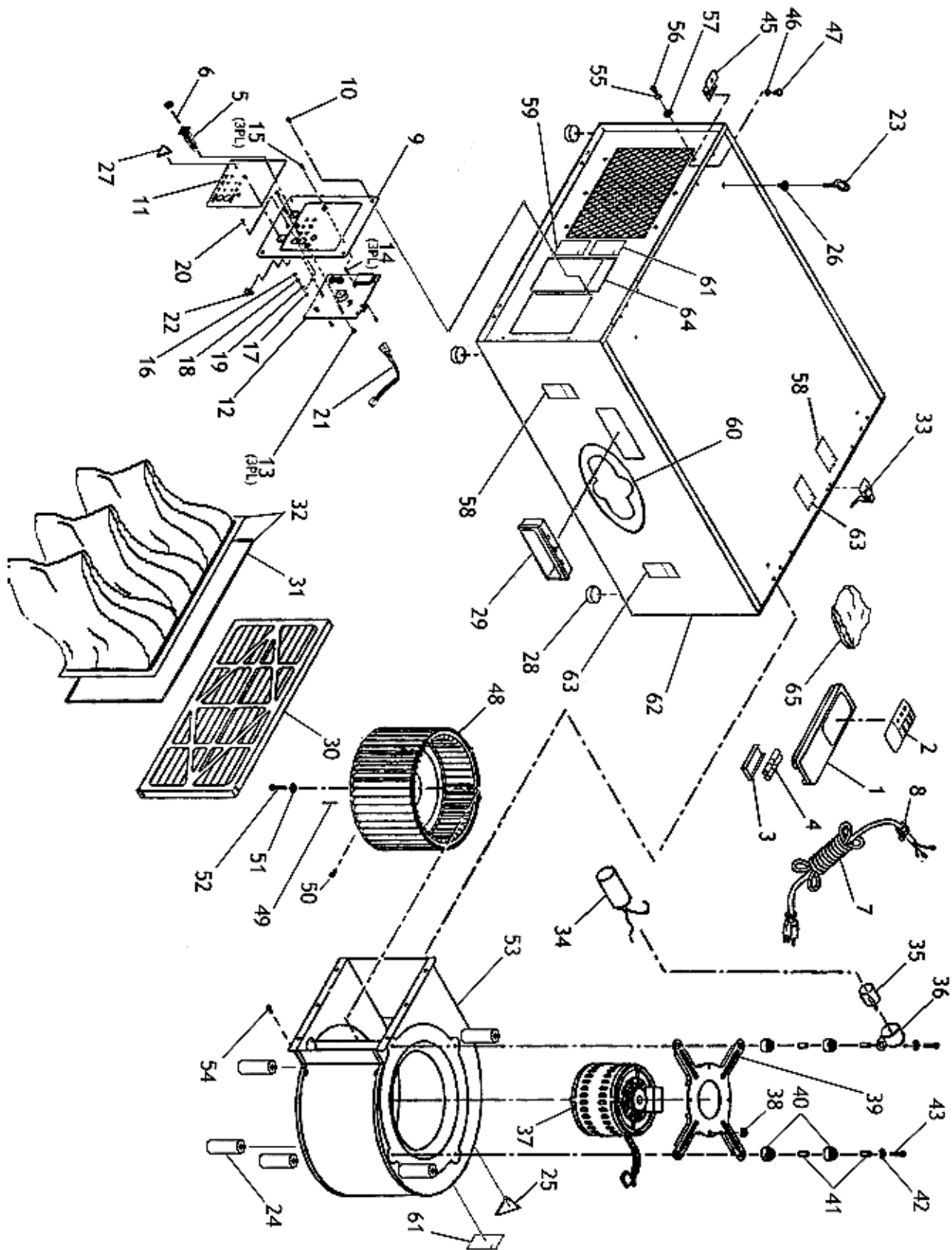

REF	PART #	DESCRIPTION
1	X1690001	REMOTE CONTROL
2	X1690002	LABEL (CONTROLS)
3	X1690003	REMOTE CONTROL COVER
4	X1690004	AAA ALKALINE BATTERY
5	X1690005	FUSE HOLDER
6	X1690006	1 <sup>1</sup> / <sub>8</sub> " FUSE 5-AMP (250VAC)
7	X1690007	POWER CORD 3-WIRE 18-GA
8	X1690008	STRAIN RELIEF
9	X1690009	CONTROL PANEL
10	XPS38M	PHLP HD SCR M4-0.7 X 10
11	X1690011	LABEL (CONTROLS)
12	X1690012	PC BOARD
13	XPS53M	PHLP HD SCR M3-0.45 X 6.5
14	X1690014	SPACER (SPECIAL)
15	X1690015	PHLP HD SCR (SPECIAL)
16	XPTLW04M	EXT TOOTH WSHR 4MM
17	XPN30M	HEX NUT M4-0.75
18	XPW05M	FLAT WASHER 4MM
19	XPLW02M	LOCK WASHER 4MM
20	XPS54M	PHLP HD SCR M4-0.75 X 6
21	X1690021	PC WIRING HARNESS
22	X1690022	BOLT (SPECIAL) M3-0.45 X 6.5
23	X1690023	EYE BOLT M6-1.0 X 20
24	X1690024	RUBBER BUSHING
25	X1690025	LARGE LABEL (ELECTRICAL)
26	X1690026	RIVET NUT M6 X 8
27	X1690027	SMALL LABEL (ELECTRICAL)
28	X1690028	RUBBER FOOT
29	X1690029	HANDLE
30	X1690030	PRIMARY FILTER 5-MICRON
31	X1690031	FOAM SEAL 1/4" X 1" X 70"
32	X1690032	SECONDARY FILTER 1-MICRON

REF	PART #	DESCRIPTION
33	X1690033	CLIP SET
34	X1690034	CAPACITOR
35	X1690035	INSULATOR
36	X1690036	CAPACITOR CLAMP
37	X1690037	MOTOR
38	XPLN02M	HEX LOCKING NUT M5-0.8
39	X1690039	FLANGE
40	X1690040	SPACER
41	X1690041	SLEEVE
42	XPW03M	FLAT WASHER 6MM
43	XPB29M	HEX BOLT M6-1.0 X 30
45	X1690045	FLANGE BRACKET
46	XPW03M	FLAT WASHER 6MM
47	XPB04M	HEX BOLT M6-1.0 X 10
48	X1690048	FAN
49	XPB48M	KEY 4 X 4 X 20MM
50	XPB06M	HEX BOLT M8-1.25 X12
51	X1690051	FLANGE DISK 6.5 X 44MM
52	X1690052	CAP SCREW M6-1.0 X 20 (LH)
53	X1690053	FAN HOUSING
54	X1690054	TAPPING SCREW
55	XPLW03M	LOCK WASHER 6MM
56	XPS11M	PHLP HD SCR M6-1.0 X 16
57	XPW03M	FLAT WASHER 6MM
58	X1690058	LABEL (DUST MASK)
59	X1690059	LABEL (EXPLODE)
60	X1690060	LABEL (SHOP FOX)
61	X1690061	LABEL (HANDS AWAY)
62	X1690062	HOUSING
63	X1690063	LABEL (UNPLUG POWER)
64	X1690064	LABEL (MACHINE DATA)
65	X1690065	MOUNT AND BOLT BAG



FOLD ALONG DOTTED LINE

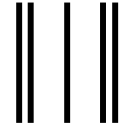
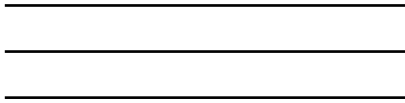

Place  
Stamp  
Here



WOODSTOCK INTERNATIONAL, INC.  
P.O. BOX 2309  
BELLINGHAM, WA 98227-2309



FOLD ALONG DOTTED LINE

TAPE ALONG EDGES--PLEASE DO NOT STAPLE

# WARRANTY CARD



Name \_\_\_\_\_  
 Street \_\_\_\_\_  
 City \_\_\_\_\_ State \_\_\_\_\_ Zip \_\_\_\_\_  
 Phone Number \_\_\_\_\_ E-Mail \_\_\_\_\_ FAX \_\_\_\_\_  
**MODEL # \_\_\_\_\_ Serial # \_\_\_\_\_ Purchase Date \_\_\_\_\_ Time in Use \_\_\_\_\_**

The following information is given on a voluntary basis and is strictly confidential.

CUT ALONG DOTTED LINE

1. Where did you purchase your **SHOP FOX®** machine?  
 \_\_\_\_\_
2. How did you first learn about us?  
 \_\_\_ Advertisement                      \_\_\_ Friend  
 \_\_\_ Mail order Catalog                \_\_\_ Local Store  
 \_\_\_ World Wide Web Site  
 \_\_\_ Other \_\_\_\_\_
3. Which of the following magazines do you subscribe to.  
 \_\_\_ American Woodworker            \_\_\_ Today's Homeowner  
 \_\_\_ Cabinetmaker                        \_\_\_ Wood  
 \_\_\_ Family Handyman                  \_\_\_ Wooden Boat  
 \_\_\_ Fine Homebuilding                 \_\_\_ Woodshop News  
 \_\_\_ Fine Woodworking                 \_\_\_ Woodsmith  
 \_\_\_ Home Handyman                     \_\_\_ Woodwork  
 \_\_\_ Journal of Light Construction    \_\_\_ Woodworker  
 \_\_\_ Old House Journal                 \_\_\_ Woodworker's Journal  
 \_\_\_ Popular Mechanics                 \_\_\_ Workbench  
 \_\_\_ Popular Science                     \_\_\_ American How-To  
 \_\_\_ Popular Woodworking  
 \_\_\_ Other \_\_\_\_\_
4. Which of the following woodworking/remodeling shows do you watch?  
 \_\_\_ Backyard America                 \_\_\_ The New Yankee Workshop  
 \_\_\_ Home Time                            \_\_\_ This Old House  
 \_\_\_ The American Woodworker        \_\_\_ Woodwright's Shop  
 \_\_\_ Other \_\_\_\_\_
5. What is your annual household income?  
 \_\_\_ \$20,000-\$29,999                    \_\_\_ \$60,000-\$69,999  
 \_\_\_ \$30,000-\$39,999                    \_\_\_ \$70,000-\$79,999  
 \_\_\_ \$40,000-\$49,999                    \_\_\_ \$80,000-\$89,999  
 \_\_\_ \$50,000-\$59,999                    \_\_\_ \$90,000 +
6. What is your age group?  
 \_\_\_ 20-29                                    \_\_\_ 50-59  
 \_\_\_ 30-39                                    \_\_\_ 60-69  
 \_\_\_ 40-49                                    \_\_\_ 70 +
7. How long have you been a woodworker?  
 \_\_\_ 0 - 2 Years                            \_\_\_ 8 - 20 Years  
 \_\_\_ 2 - 8 Years                            \_\_\_ 20+ Years
8. How would you rank your woodworking skills?  
 \_\_\_ Simple                                 \_\_\_ Advanced  
 \_\_\_ Intermediate                         \_\_\_ Master Craftsman
9. How many **SHOP FOX®** machines do you own? \_\_\_\_\_
10. What stationary woodworking tools do you own? Check all that apply.  
 \_\_\_ Air Compressor                      \_\_\_ Panel Saw  
 \_\_\_ Band Saw                                \_\_\_ Planer  
 \_\_\_ Drill Press                               \_\_\_ Power Feeder  
 \_\_\_ Drum Sander                            \_\_\_ Radial Arm Saw  
 \_\_\_ Dust Collector                        \_\_\_ Shaper  
 \_\_\_ Horizontal Boring Machine        \_\_\_ Spindle Sander  
 \_\_\_ Jointer                                  \_\_\_ Table Saw  
 \_\_\_ Lathe                                      \_\_\_ Vacuum Veneer Press  
 \_\_\_ Mortiser                                 \_\_\_ Wide Belt Sander  
 \_\_\_ Other \_\_\_\_\_
11. Which benchtop tools do you own? Check all that apply.  
 \_\_\_ 1" x 42" Belt Sander                 \_\_\_ 6" - 8" Grinder  
 \_\_\_ 5" - 8" Drill Press                    \_\_\_ Mini Lathe  
 \_\_\_ 8" Table Saw                            \_\_\_ 10" - 12" Thickness Planer  
 \_\_\_ 8" - 10" Bandsaw                    \_\_\_ Scroll Saw  
 \_\_\_ Disc/Belt Sander                     \_\_\_ Spindle/Belt Sander  
 \_\_\_ Mini Jointer  
 \_\_\_ Other \_\_\_\_\_
12. Which portable/hand held power tools do you own? Check all that apply.  
 \_\_\_ Belt Sander                            \_\_\_ Orbital Sander  
 \_\_\_ Biscuit Joiner                        \_\_\_ Palm Sander  
 \_\_\_ Circular Saw                            \_\_\_ Portable Planer  
 \_\_\_ Detail Sander                         \_\_\_ Saber Saw  
 \_\_\_ Drill/Driver                            \_\_\_ Reciprocating Saw  
 \_\_\_ Miter Saw                                \_\_\_ Router  
 \_\_\_ Other \_\_\_\_\_
13. What machines/supplies would you like to see?  
 \_\_\_\_\_  
 \_\_\_\_\_  
 \_\_\_\_\_
14. What new accessories would you like Woodstock International to carry?  
 \_\_\_\_\_  
 \_\_\_\_\_
15. Do you think your purchase represents good value?  
 \_\_\_ Yes                                        \_\_\_ No
16. Would you recommend **SHOP FOX®** products to a friend?  
 \_\_\_ Yes                                        \_\_\_ No
17. Comments: \_\_\_\_\_  
 \_\_\_\_\_  
 \_\_\_\_\_  
 \_\_\_\_\_  
 \_\_\_\_\_



