

n



**Plasma display
television
Service Manual**

Classis: PW118C + PW2300B

**Product Type: PDH4239EU
PDH5039EU**

Ver 1.0

**Hisense Electric co., Ltd.
R&D Center PDP Institute**

01, 2007

Contents

Contents..... -2-
Service Manual..... -2-
1. Product Safety Servicing Guidelines..... -3-
 1-1 Safety precautions.....-3-
 1-2 Product Safety notice.....-3-
2. Product Function Specifications.....-4-
 2-1 PDH4239EU product function.....-4-
 2-2 PDH4239EU specifications.....-4-
3. PDP panel spec.....-7-
 3-1 General description.....-7-
 3-2 Panel block diagram.....-8-
 3-3 Power (PSU) description..... -8-
 3-4 Power block diagram.....-9-
4. Block Diagram.....-10-
 4-1 unite sketch map.....-10-
 4-2 Video processing diagram.....-14-
 4-3 Audio processing diagram.....-15-
5. Service Mode and Adjustment..... -15-
 5-1 Service mode.....-15-
6. Software updating.....-20-
 6-1 PDH4239EU software updating.....-20-
7. PDH4239EU Explode View and Bom.....-21-
 7-1 Spare Parts List.....-21-
9. Troubleshooting.....-22-
10. Stand installing..... -24-
11. PDP Wall-mounting Bracket Installation Guide.....-25-
12. Circuit Diagram.....-28-

Product Safety Servicing Guidelines

CAUTION: BEFORE SERVICING THE CHASSIS, READ THE “SAFETY PRECAUTION” “PRODUCT SAFETY NOTICE” ON PAGE 3 OF THIS MANUAL.

1. Safety precautions

WARNING:

Service should not be attempted by anyone unfamiliar with the necessary precaution on this receiver. The following are the necessary precautions to be observed before servicing this chassis.

1. When replacing a chassis in the cabinet, always be certain that all the protective devices are put back in place, such as: non-metallic control knobs, insulating covers, shields, isolation resistor-capacitor network etc.
2. When replacing parts or circuit boards, disconnect the power cord.
3. When replacing a high wattage resistor (oxide metal film resistor) on the circuit board, keep the resistor 10mm (1/2in) away from circuit board.
4. Connection wires must be kept away from components with high voltage or high temperature.
5. If any fuse in this TV receiver is blown, replace it with the FUSE specified in the chassis parts list.

2. Product Safety notice

Many electrical and mechanical parts in the chassis have special safety-related characteristics.

These characteristics are often passed unnoticed by a visual inspection.

Replacement parts, which have these special safety characteristic are identified in this manual and its supplement electrical components having such features are shaded on the schematic diagram and the parts list.

Before replacing any of these components, read the parts list in this manual carefully. The use of substitute replacement parts, which do not have the same characteristic as specified in the parts list may create shock, fire or other hazards.

NOTES:

Screen Image retention Do not display a still image (such as on a video game or when hooking up a PC to this PDP) on plasma monitor panel for a long time as it can cause screen image retention. This image retention is also known as “screen burn”. To avoid such image retention, reduce the degree of brightness and contrast of the screen when displaying a still image.

A still image displayed too long may cause permanent damage to the PDP Panel Watching the PDP TV in 4:3 format or other non full screen formats for a long period of time may leave traces of borders displayed on the left, right and centre of the screen caused by the difference of light emission on the screen. Playing a DVD or a game console may cause similar effect to the screen. Damages caused by the above effect are not covered by the Warranty.

Afterimage on the Screen Displaying still images from Video games and PC for longer than a certain period of time may produce partial afterimages. To prevent this effect, reduce the brightness and contrast when displaying still images for a long time.

Height The PDP can normally operate only under 2000m in height. It might abnormally function at a place over 2000m in height and do not install and operate there.

Avoid operating the TV at temperatures below 5°C(41°F)

Warranty Warranty does not cover any damage caused by image retention; Burn-in is not covered by the warranty.

Product Function Specifications

1. PDH4239EU product function



- High end flat display
- HDMI input
- High definition compatible
- Wide Screen display optimized for cinema viewing
- Multimedia display :TV/PC
- High clear picture
- Audio equalizer
- Color enhancer ,contrast enhancer
- High brightness, high contrast
- Two Scarts ,Scart1 (RGB/CVBS),Scart2(Y\C/CVBS)

2. PDH4239EU specifications

Connecting the TV set

Overview

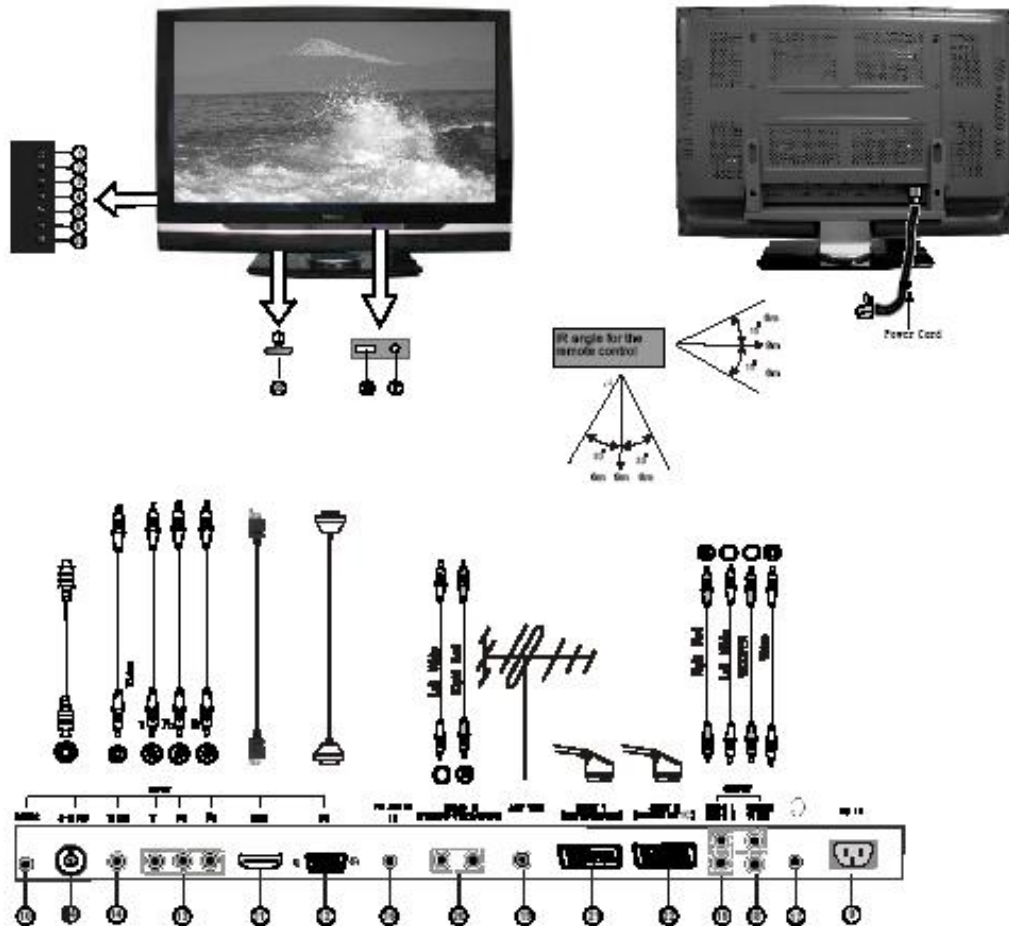

1	Menu key : activate OSD menu	14	Video input
2	Source key : activate OSD source selector	15	TV antenna input
3	VOL+ : increase the volume level / right arrow key	16	PC Audio input
4	VOL- : decrease the volume level / left arrow	17	Headphone output
5	CH+ : next channel stored / up arrow key	18	Video output
6	CH- : previous channel stored / down arrow key	19	Audio output
7	Power indicator	20	Audio input (Video/S-Video/YPBPR)
8	Remote sensing window	21	Scart 1
9	AC power socket	22	Scart 2
10	RS232 (service only)	23	Power switch (Standby)
11	HDMI Input	24	S-Video input
12	PC input	25	Power switch (on/off)
13	YPbPr input		

Note: The above figures are for reference only, please refer to the actual Units to determine the appearances.

PDP TV Service Manual

	PDH4239EU	
PDP panel	Plasma panel 42"	
Native Screen Resolution	1024 x 768	
Television system	SECAM/PAL	
Sound system	BG / DK / I	
Channel coverage	VHF-L: E2-S8 VHF-H: S9-S37 UHF: S38-E69	
PC mode (DB15)	60Hz	640 x 480, 800 x 600, 1024 x 768
YPBPR mode	50Hz	576 i/p, 720p, 1080i
	60Hz	480i /P, 720p, 1080i
HDMI mode	RGB	640 x 480, 800 x 600, 1024 x 768
	YPBPR 50Hz	576p, 720p, 1080i
	YPBPR 60Hz	480p; 720p, 1080i
Static contrast ratio	10000 : 1	
Brightness	1200 cd/m ²	
Viewing angle	160° (H/V)	
Power source	AC 100V-240V, 50/60Hz	
Power consumption	300W	
Audio output	2 x 7 watts	
Audio filter	Equalizer 5 x bands	
Connection interface	RF Input:	RF Antenna x 1
	Video Input:	YUV x 1 ,S-Video x 1,AV x 1
	Graphic Input:	PC analog (DB15) x 1,HDMI x 1 (HDCP)
	Audio Input:	YUV x 1 ,S-Video /AV x 1,PC analog (DB15) x 1
	Audio Output:	audio output x 1 headphone x 1 (Jack 3,5mm)
	Video Output:	video output x 1
	Other:	RS232 (Service use only)
Dimensions	1054mmX812mmX331mm (LXWXH) (including stand)	

Hi sense confidenti al

PDP panel spec

1. General description

The PDP42X3##### 42-inch 16:9 color plasma display module with resolution of 1024(H) × 768(V) pixels. This is the display device which offers vivid colors with adopting AC plasma technology by LG Electronics Inc.

- ✓ Model Name : PDP42X3##### (42X3##### Model)
- ✓ Number of Pixels : 1024(H) × 768(V) (1pixel=3 RGB cells)
- ✓ Pixel Pitch : 900 μ m (H) × 676 μ m (V)
- ✓ Cell Pitch : 300 μ m (H) × 676 μ m (V) (Green Cell basis)
- ✓ Display Area : 920.1(H) × 518.4(V) \pm 0.5mm
- ✓ Outline Dimension : 1005(H) × 597(V) × 61.2(D) \pm 1mm
- ✓ Pixel Type : RGB Closed type
- ✓ Number of Gradations : (R)1024 × (G)1024 × (B)1024
- ✓ Weight : 15.3 Kg \pm 0.5 Kg (Net 1EA)
113.5 Kg \pm 5 Kg (5EA/1BOX)
- ✓ Aspect Ratio : 16:9
- ✓ Peak Brightness : Typical 1200cd/m² (1/100 White Window)
- ✓ Contrast Ratio : Typical 50:1 (In a bright room with 150Lux at center)
: Typical 10000:1 (In a dark room 1/100 White Window pattern at center)
- ✓ Power Consumption : Typical 280 W (Full White)
- ✓ Expected Life-time : more than 60,000 Hours of continuous operation

☞ Life-time is defined as the time when the brightness level becomes half of its initial value.

- ✓ Display Dot Diagram

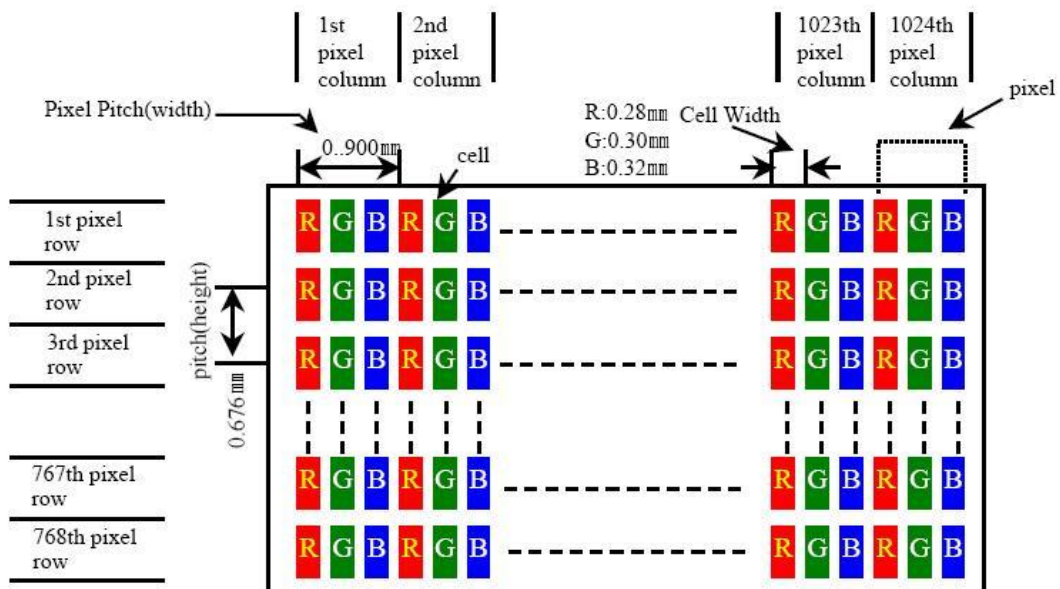

2. Panel block diagram

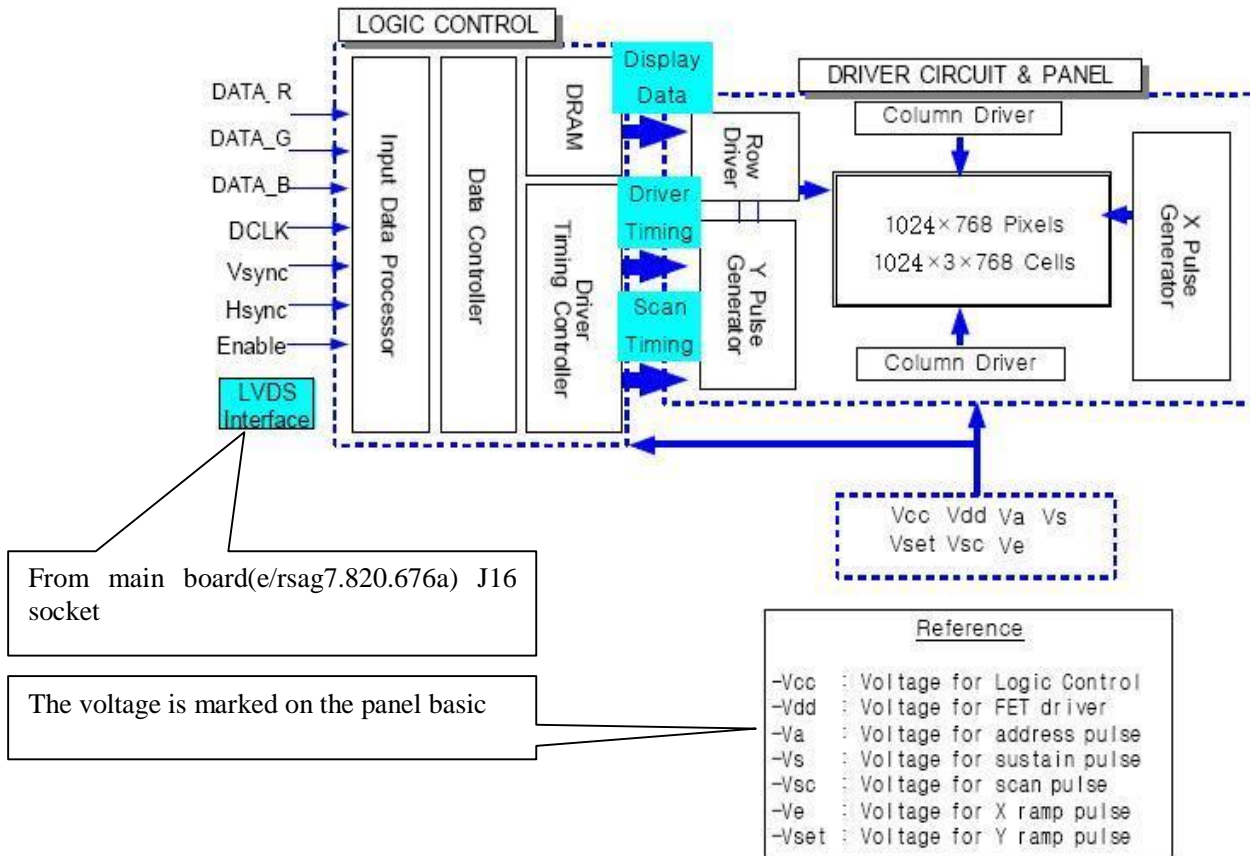

3. Power (PSU) description

Standard Voltage Range	AC 100V ~ 240V
Available Voltage Range	AC 90V ~ 265V
Frequency Range	50Hz ~ 60Hz (± 3Hz)

4. Power block diagram

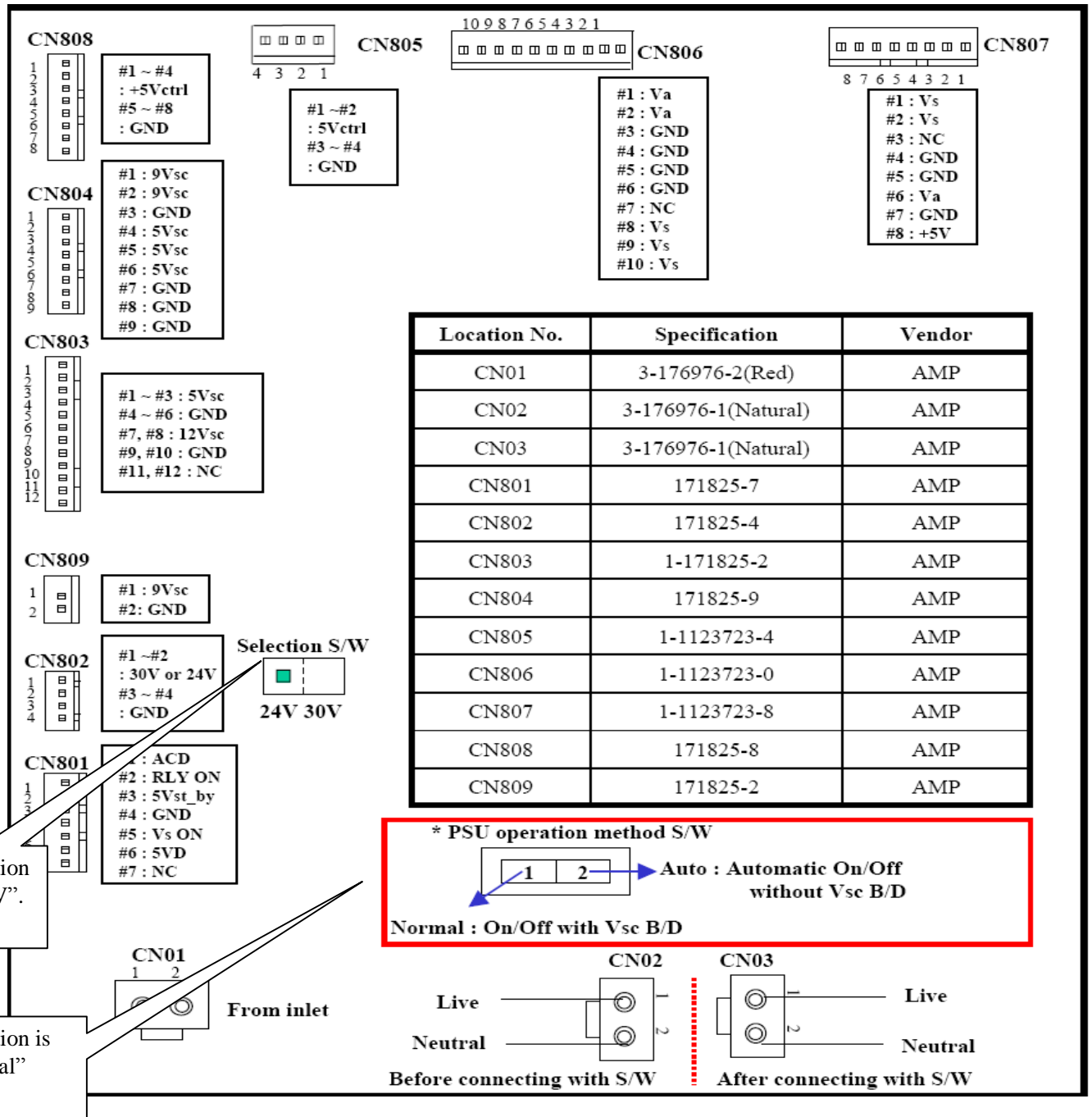

Block Diagram

The signal board is composed by the main board and the audio board. The main chip for video decoder is Pw2300 produced by pixelworks co., ltd. and the scaler chip is PW118C. the audio processing chip is msp34x0 produced by microchip co., ltd. And the audio amplifier is TA8200H .

1. unite sketch map

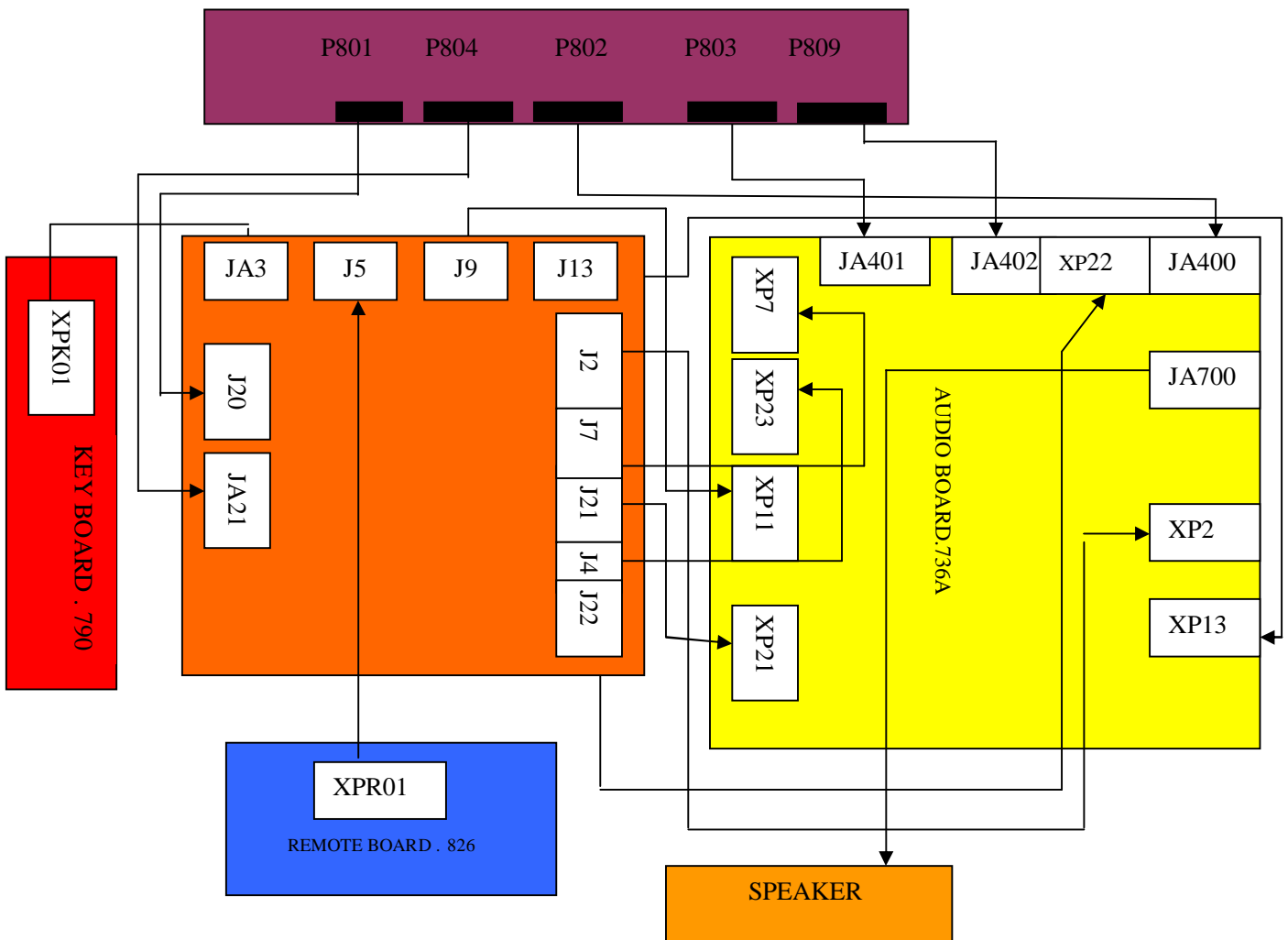

FUNCTION OF CONJUNCTIONS

P801---J20

ITEM	NAME	FUNCTION
1	ACD	
2	RLY_ON	HIGH LEVEL
3	5VSTB	
4	GND	
5	VSON	HIGH LEVEL
6	5VD	
7	NC	

P804---JA21

ITEM	NAME	FUNCTION
1	9VSC	SIGNAL POWER
2	9VSC	SIGNAL POWER
3	GND	
4	5VSC	SIGNAL POWER
5	5VSC	SIGNAL POWER
6	5VSC	SIGNAL POWER
7	GND	
8	GND	
9	GND	

P803---JA401

ITEM	NAME	FUNCTION
1	5VSC	NO USED
2	5VSC	NO USED
3	5VSC	NO USED
4	GND	
5	GND	
6	GND	
7	12VSC	MSP3410/MAD4868
8	12VSC	MSP3410/MAD4868
9	GND	
10	GND	
11	12VF	NO USED
12	GND	

P802---JA400

ITEM	NAME	FUNCTION
1	30V	TA8200AH
2	30V	TA8200AH
3	GND	
4	GND	

P809---JA402

ITEM	NAME	FUNCTION
1	9V	TUNER POWER
2	GND	

J13---XP13

ITEM	NAME	FUNCTION
1	GND	
2	SDATA	HDMI AUDIO DATA
3	SCLK	HDMI CLOCK
4	GND	
5	LRCK	AUDIO CLOCK
6	MCLK	HDMI CLOCK

J2---XP2

ITEM	NAME	FUNCTION
1	GND	
2	SCL	BUS CLOCK
3	SDA	BUS DATA
4	NC	
5	MUT1	CONTROL SIGNAL
6	MUT2	
7	VOL	
8	RST	RESET SIGNAL

J21-XP21

ITEM	NAME	FUNCTION
1	GND	
2	SPDIF	NO USED
3	ID2	NO USED
4	ID1	TUNER SYNC PULSE
5	SW0	NO USED
6	SW1	NO USED
7	331_1	SCART 1/SCART2 CONTROL
8	331_0	

J9---XP11

ITEM	NAME	FUNCTION
1	V_M	TUNER CVBS
2	GND	
3	V_P	NO USED
4	GND	

XP01---JA3

ITEM	NAME	FUNCTION
1	K101	5VSTB
2	K102	CH-
3	K103	CH+
4	K104	VOL-
5	K105	VOL+
6	K106	SOURCE
7	K107	MENU
8	GND	

PDP TV Service Manual

J5---XPR01

ITEM	NAME	FUNCTION
1	IR1	REMOTE CONTROL
2	GND	
3	LED1	NO USED
4	LED2	NO USED
5	GND	
6	5VST_BY	POWER OF REMOTE

J7---XP7

ITEM	NAME	FUNCTION
1	CVBS1-IN	SCART2 Y
2	GND	
3	C-IN	SCART2 C
4	GND	
5	Y-IN	SCART2 Y
6	GND	
7	CVBS1-OUT	NO USED
8	GND	
9	CVBS2-OUT	VIDEO OUT
10	GND	
11	GPIO	SCART1 SWITCH

J4---XP23

ITEM	NAME	FUNCTION
1	SC-G	SCART1 GREEN SIGNAL
2	GND	
3	SC-B	SCART1 BLUE SIGNAL
4	GND	
5	SC-R	SCART1 RED SIGNAL
6	GND	

J22---XP22

ITEM	NAME	FUNCTION
1	SWI2	SCART2 SWITCH
2	GND	
3	SC-FB	SCART1 FAST BLANK
4	GND	

Hi sense confident al

2. Video processing diagram

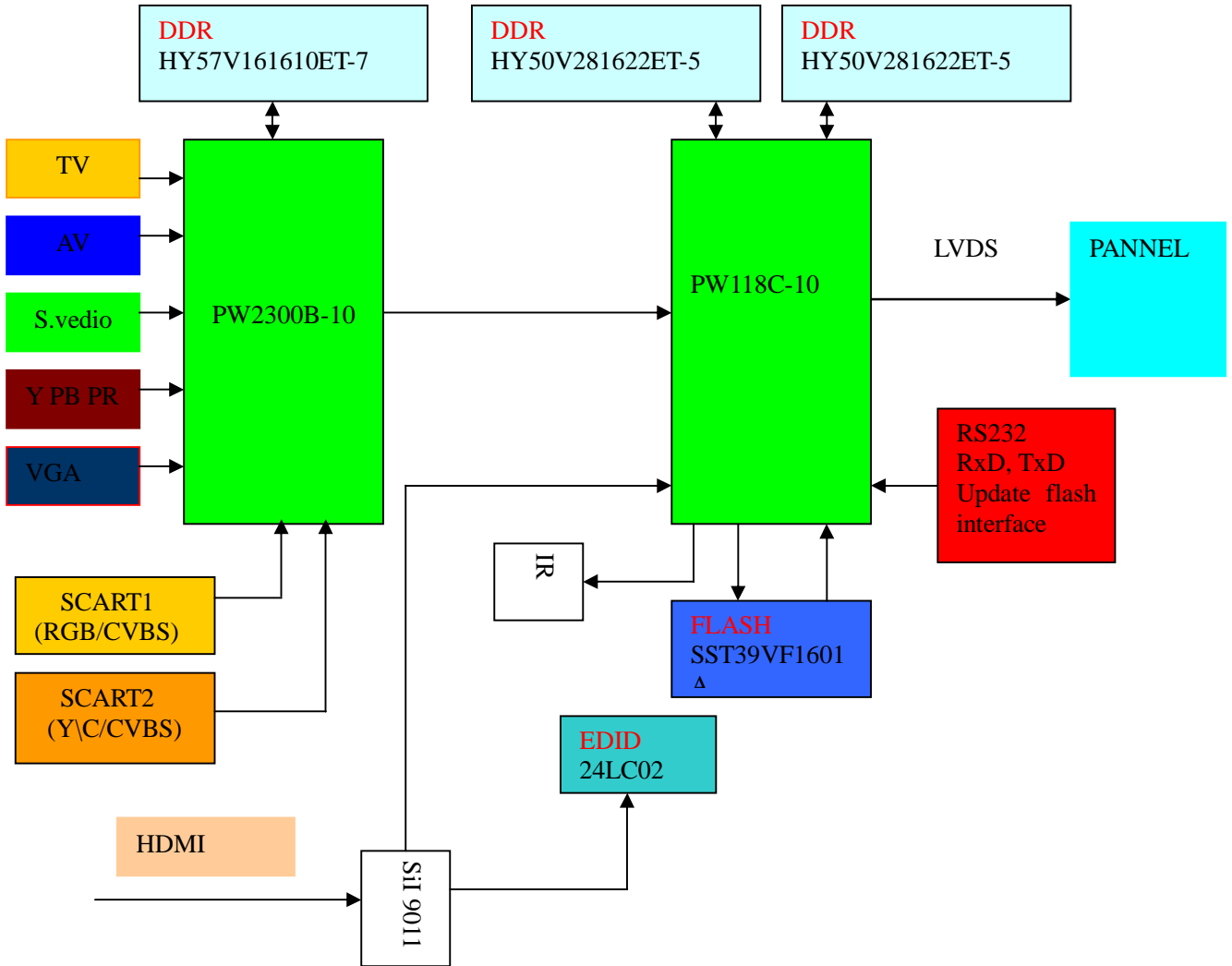

3. Audio processing diagram

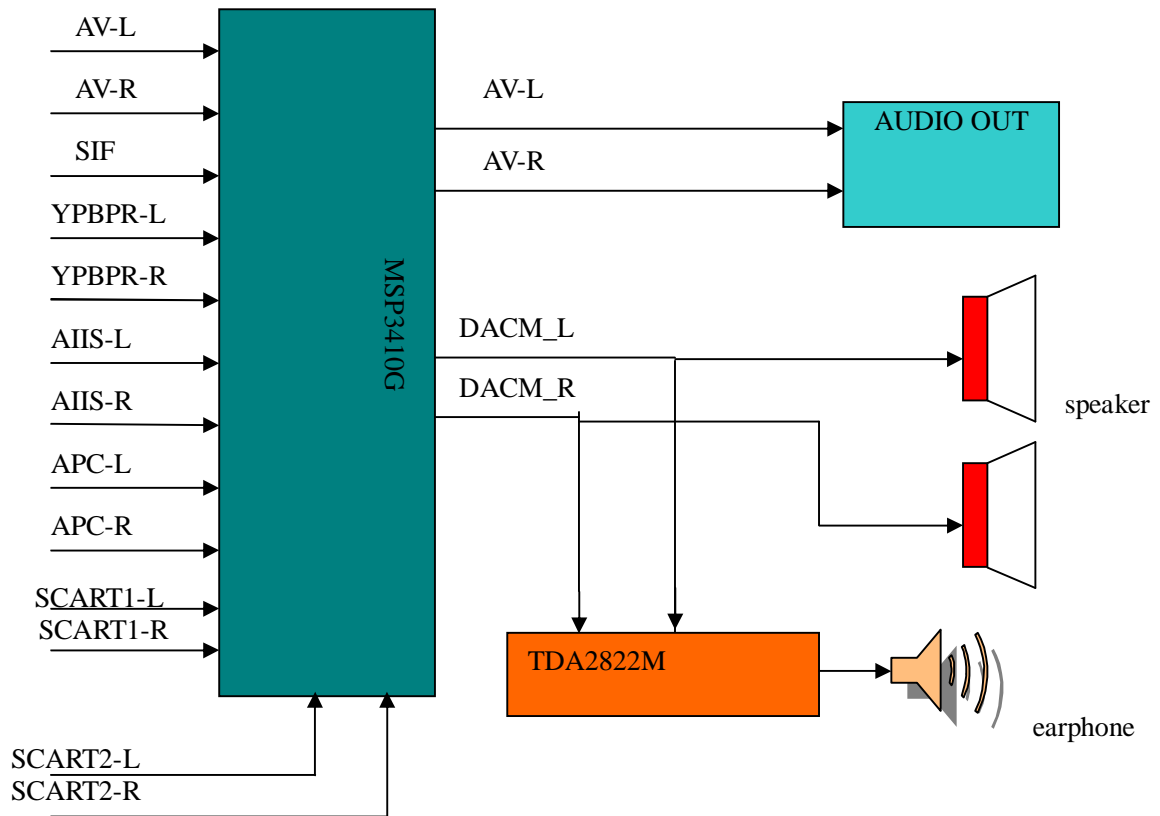

Service Mode And Adjustment

1. Service mode

You can entry service mode menu by follow steps:

1. Press on the [MENU] key.
2. Select the sub-menu [Audio] with [VOL+/VOL-].
3. Select the parameter [balance] with the keys [CH+/CH-].
4. Press a series of numbers [0] [5] [3] [2] quickly.

SERVICE MODE MENU includes:

1. PC mode:

PDP TV Service Manual

WHITE BALANCE: adjust white balance

WBL Bright	126
WBL Contrast	30
WBH Bright	60
WBH Contrast	60
RDRV	65
GDRV	72
BDRV	77
RCUT	-4
GCUT	0
BCUT	+12

PICTURE SETTINGS: adjust picture mode. If you adjust these data, date of all signal picture will increase same data.

STD Brightness	52	Picture normal mode
STD Contrast	75	
DYN Brightness	55	Picture bright mode
DYN Contrast	85	
SOFT Brightness	45	Picture soft mode
SOFT Contrast	50	
HDMISEL	SIL9011	

SOUND SETTIINGS: adjust sound curve.

STD 120Hz	100
STD 500Hz	80
STD 1.5KHz	88
STD 5KHz	100
STD 10KHz	120
Music 120Hz	114
Music 500Hz	80
Music 1.5KHz	88
Music 5KHz	110
Music 10KHz	142
Speech 120Hz	60
Speech 500Hz	92
Speech 1.5KHz	84
Speech 5KHz	70
Speech 10KHz	60
Max Volume	112
Middle Volume	96
Volume 20	88
Min Volume	45
Deviation	360KHZ
Prescale	30
Carrier Mute	000
Sound Delay 10ms	005
Sound delay 100ms	001

FACTORY INI: Clear room
Set channel zhongshi
ATS switch ATS_ON

OPTIONS:

Hi sense confident al

PDP TV Service Manual

TOFAC	M
OSD Language	English
Test Pattern	关闭
Pixel Shift Number	001
Pixel Shift Time	030
TTX cycle	004
TTX line	150

PW318B:

Panel Selection	0
Analog RGB Calibration	
YPbPr Calibration	
Factory Reset	
BW Expand	0
CUEC/ICP	1
FRMEC	1
Flesh tone correction	0
Film mode	1
3:2 Film sensitivity	4
2:2 Film sensitivity	4
Pixel Boost	0
DCS	0
DLTI	1
Peaking	1
Spatial Noise Filter	0
Lump Temp Noise Filter	64
LAI	2

PWX300:

Selected Feta	0
3D Comb Filter	1
FTC Level	128
FTC Angel	35
DCTI Gain	7
DCTI Frequency	0
DLTI Gain	0
DLTI Frequency	0
Luma peaking Gain	0
Luma peaking L Threash	1
Luma peaking U Threash	128
Luma peaking L Trans	0
Luma peaking U Trans	0
Luma Sharpness Gain	0
Luma Sharpness Frequency	3
Black Stretch	128
White Stretch	128

2. TV mode:

WHITE BALANCE: adjust white balance.

WBL Bright	30
WBL Contrast	30
WBL Colour	30

Hi sense confident al

PDP TV Service Manual

WBH Bright	60
WBH Contrast	60
WBH Colour	60
RDRV	75
GDRV	82
BDRV	83
RCUT	-5
GCUT	-18
BCUT	10

PICTURE SETTINGS: adjust picture mode. If you adjust these data, date of all signal picture will increase same data.

STD Brightness	50	picture normal mode
STD Contrast	75	
STD Colour	60	
DYN Brightness	55	picture bright mode
DYN Contrast	78	
DYN Colour	60	
SOFT Brightness	50	picture soft mode
SOFT Contrast	60	
SOFT Colour	50	
HDMISEL	SIL9011	

SOUND SETTIINGS: the same to PC mode

FACTORY INI: the same to PC mode

OPTIONS: the same to PC mode

PW318B: the same to PC mode

PWX300: the same to PC mode

3. AV /scart1/scart2/s-video mode:

WHITE BALANCE: adjust white balance.

WBL Bright	30
WBL Contrast	30
WBL Colour	30
WBH Bright	60
WBH Contrast	60
WBH Colour	60
RDRV	75
GDRV	82
BDRV	83
RCUT	-5
GCUT	-18
BCUT	10

PICTURE SETTINGS: adjust picture mode. If you adjust these data, date of all signal picture will increase same data.

STD Brightness	50	picture normal mode
STD Contrast	75	
STD Colour	60	
DYN Brightness	55	picture bright mode
DYN Contrast	85	
DYN Colour	60	

Hi sense confident ial

PDP TV Service Manual

SOFT Brightness	50	picture soft mode
SOFT Contrast	60	
SOFT Colour	50	
HDMISEL	SIL9011	

SOUND SETTIINGS: the same to PC mode

FACTORY INI: the same to PC mode

OPTIONS: the same to PC mode

PW318B: the same to PC mode

PWX300: the same to PC mode

4.YPBPR mode:

WHITE BALANCE: adjust white balance.

WBL Bright	30
WBL Contrast	30
WBL Colour	30
WBH Bright	60
WBH Contrast	60
WBH Colour	60
RDRV	45
GDRV	43
BDRV	45
RCUT	-17
GCUT	1
BCUT	-16

PICTURE SETTINGS: adjust picture mode. If you adjust these data, date of all signal picture will increase same data.

STD Brightness	70	picture normal mode
STD Contrast	60	
STD Colour	50	
DYN Brightness	75	picture bright mode
DYN Contrast	65	
DYN Colour	50	
SOFT Brightness	60	picture soft mode
SOFT Contrast	50	
SOFT Colour	50	
HDMISEL	SIL9011	

SOUND SETTIINGS: the same to PC mode

FACTORY INI: the same to PC mode

OPTIONS: the same to PC mode

PW318B: the same to PC mode

PWX300: the same to PC mode

NOTE: We advise service hadn't better amend factory data, because it is better settings data.

Please do not tell user the purpose password.

Hi sense confidential

Software updating

PDH4239EU software updating

You can update our television's software through a special RS232 cable (shown as below).

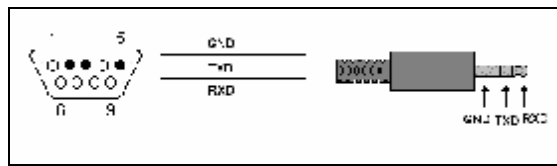

This RS232 cable includes a 9 PIN D-SUB FEMALE (left of above figure) , a 3.5mm Stereo Earphone plug and 3 wires(right of above figure). Built the cable as shown.

Serial (PC 9)

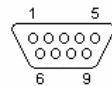

(At the Computer)

9 PIN D-SUB MALE at the Computer.

Pin	Name	Dir	Description
1	CD	←	Carrier Detect
2	RXD	←	Receive Data
3	TXD	→	Transmit Data
4	DTR	→	Data Terminal Ready
5	GND	→	System Ground
6	DSR	←	Data Set Ready
7	RTS	→	Request to Send
8	CTS	←	Clear to Send
9	RI	←	Ring Indicator

update software Steps:

1. Be sure to power on the TV set.
2. Be sure to turn the TV set to "standby" status. (Use the Power button on the remote)
3. Be sure to plug a cable on one of your PC's serial ports.(For example Serial Port 1)
4. Be sure to plug the other end of the cable on the appropriate position on the TV set (RS232 port).
5. copy the update folder to your pc.

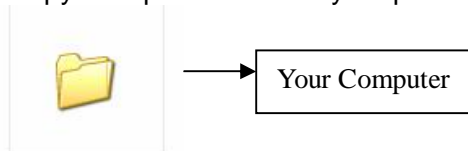

6. Find the folder and open the appropriate application software (FlashUpgrader.exe).
7. Follow the settings of the application software (FlashUpgrader). (See upgradedemo.bmp)

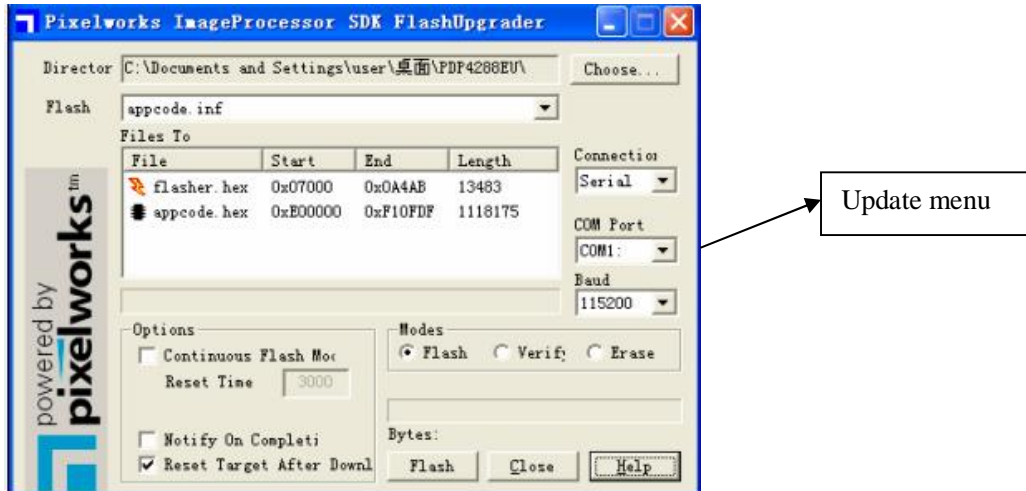

8. Be sure all the steps above are correct.
9. Press the "Flash" button on the bottom of the interface of the application software (FlashUpgrader).
10. Turn the TV set on. (Use the Power key on the remote)
Warning: Must not turn off the PDP in the updating process!

PDH4239EU Explode View and Bom

Spare Parts List

Main Spare Parts

	Name	Type	Part No.
1	SPEAKER SET	WG5.834.002\ROH	1035046
2	STAND MODULE PART	PZ004\DQ-12 罩光\ROH	109884
3	AUDIO MODULE PART	RSAG2.908.847\ROH	109984
4	MAIN BOARD MODULE	RSAG2.908.977\ROH	111995
5	KEY BOARD	RSAG2.908.828\ROH	109939
6	PORT MODULE	RSAG2.908.829\ROH	109937
7	EMI FILTER GLASS	FG420NAA-05\JK \ROH	1032693
8	TUNER PORT	KP0549\ROH	1031041
9	FRONT MODULE PART	RSAG8.074.308\Z0\ROH	1034954
10	PDP MODUEL	PDP42X3\保税\ROH	1032686
11	REMOTE CONTROL	EN-21602A\ROH	1031051

Troubleshooting

1.

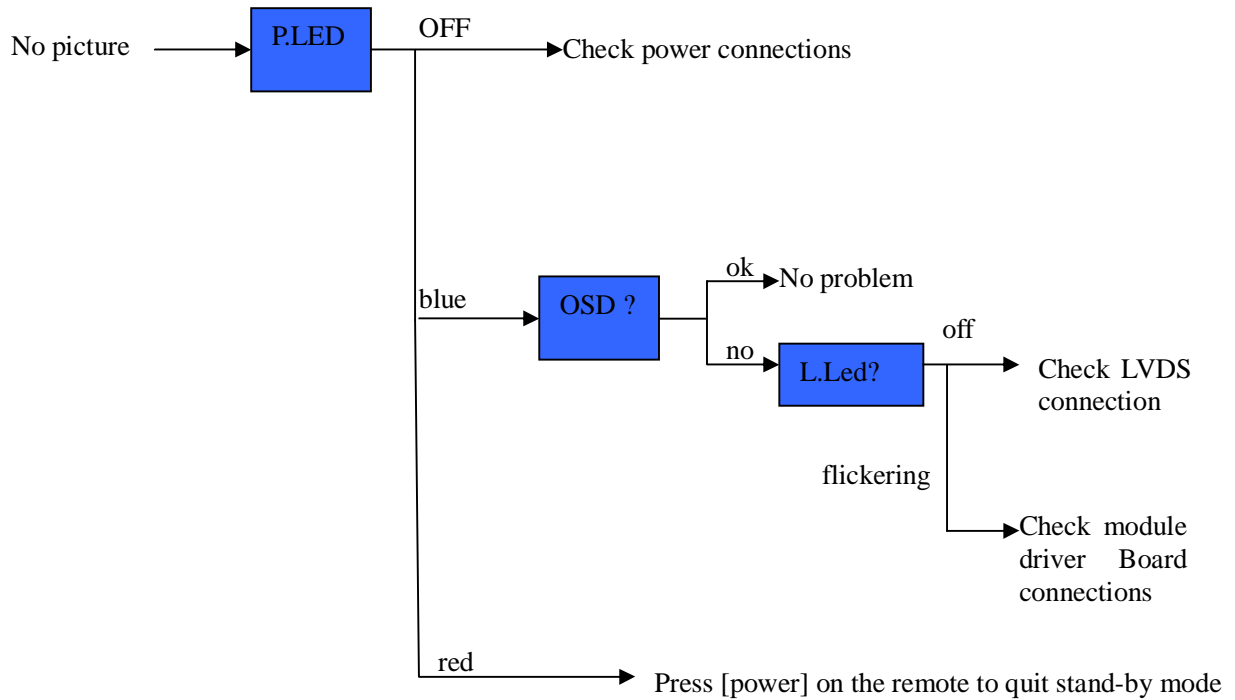

2.

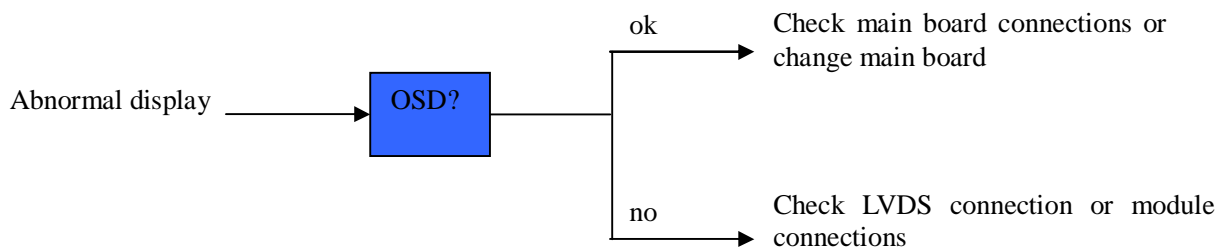

3.

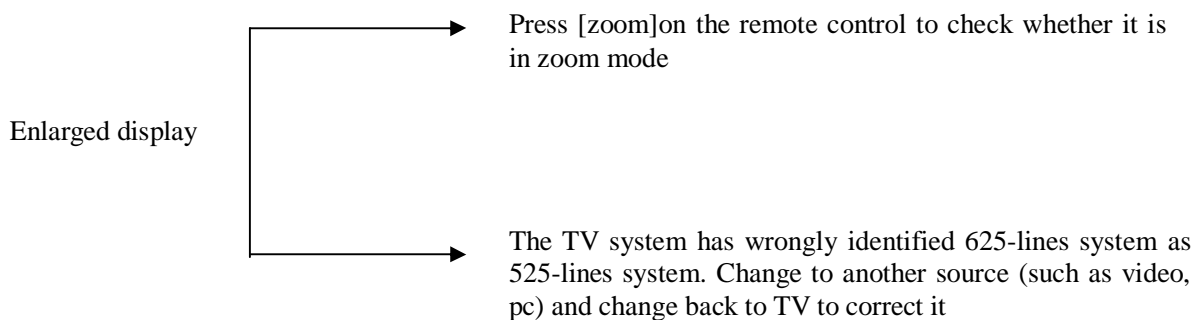

4.

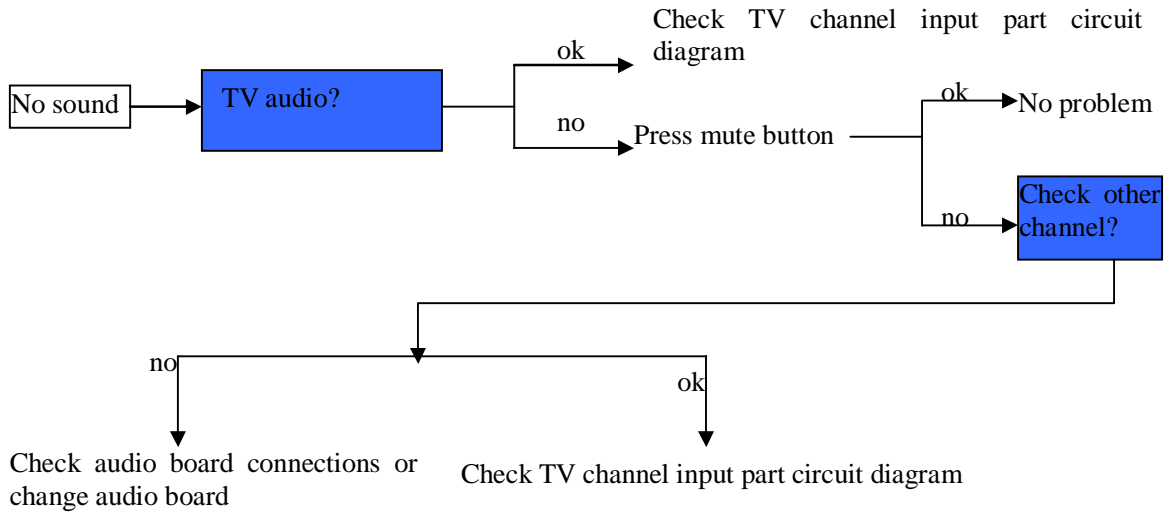

5.

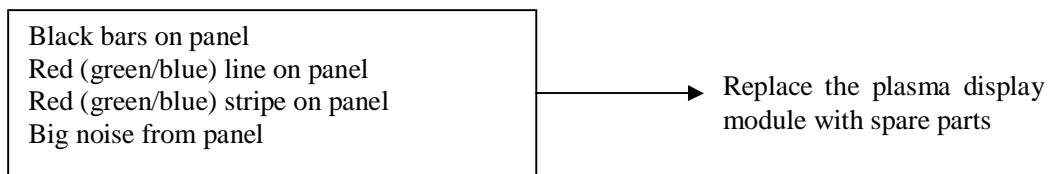

Note:

p.LED?

Power indicator at the centre of the front panel. Normal state : blue; remote command state: blue flickering.

L.LED?

LVDS indicator on the logic processing board. Normal state: yellow flickering.

OSD?

Press [MENU] to display menu on the screen.

Problem solutions:

1. Adjusting sharpness can improve picture definition.
2. Adjusting bright can improve picture administrative levels, it can display black background something.
3. If VGA or YPBPR color isn't natural. You can optimize VGA.
4. PDP power is very large system. As you power off power. Power component must discharge period of time. Power can work steadily. If you power off and power on TV continuously. Then power work unsteadily. Then PDP TV will display deviant picture.
5. TV, AV and S.video are the same white balance setting. VGA is a set white balance setting. HDTV is a set white balance setting.
6. Picture mode does be divided four modes. such as standard, brightness, soft and custom. If you adjust factory data, they will increase the same data.
7. If IC don't work normally, it will take place follow some phenomena.
 - (1) MSP3410 don't work normally. PC, YPBPR, HDMI, Audio out aren't audio. Please check its SDA , SCL ,reset and power.
 - (2) PW118C don't work normally. All signal and OSD signal are problem. You can press it, and notice picture change.
 - (3) PW2300 don't work normally. signal and OSD signal are problem. You can press it, and notice picture change. Such as , picture noise.
 - (4) LVDS connector is problem. All signal and OSD signal are problem. You can press it, and notice picture change.
 - (5) 24LC64 is problem. They can't remember, such as Bright data, contrast data, etc
 - (6) 24LC21 is problem. Some HDMI signal couldn't display normally.
 - (7) FLASH is problem. TV can't turn on power. Color of indicator light is problem. It is purple. Please update software.
 - (8) If you can't update software. Please check software settings and RS232.
8. If the picture color is not correct in the scart1 RGB source, but the scart1 CVBS is normal .you can check the fast blank signal is whether high. If it is low, please check the circuit.
- 9.If the picture is not normal 16:9 mode or 4:3 mode when the signal equipment send 16:9 mode or 4:3 mode, please check the aspect mode whether is in "normal" mode.

Stand installing

Assemble instruction

Mount Installation

Mount Preparation

1. Take the mounting components out of the box.
2. Fix stanchion A and stanchion B onto the base subassembly with two screws (M6x20) as Fig.1, turn the screws to tighten it.
3. Assemble the base subassembly onto the TV set with screw (M8X15) and screw (M5X12) as Fig.2.You can find these screws in the box of the base.

NOTE: Failure to do so may result in breaking, denting and scratching the plasma display.

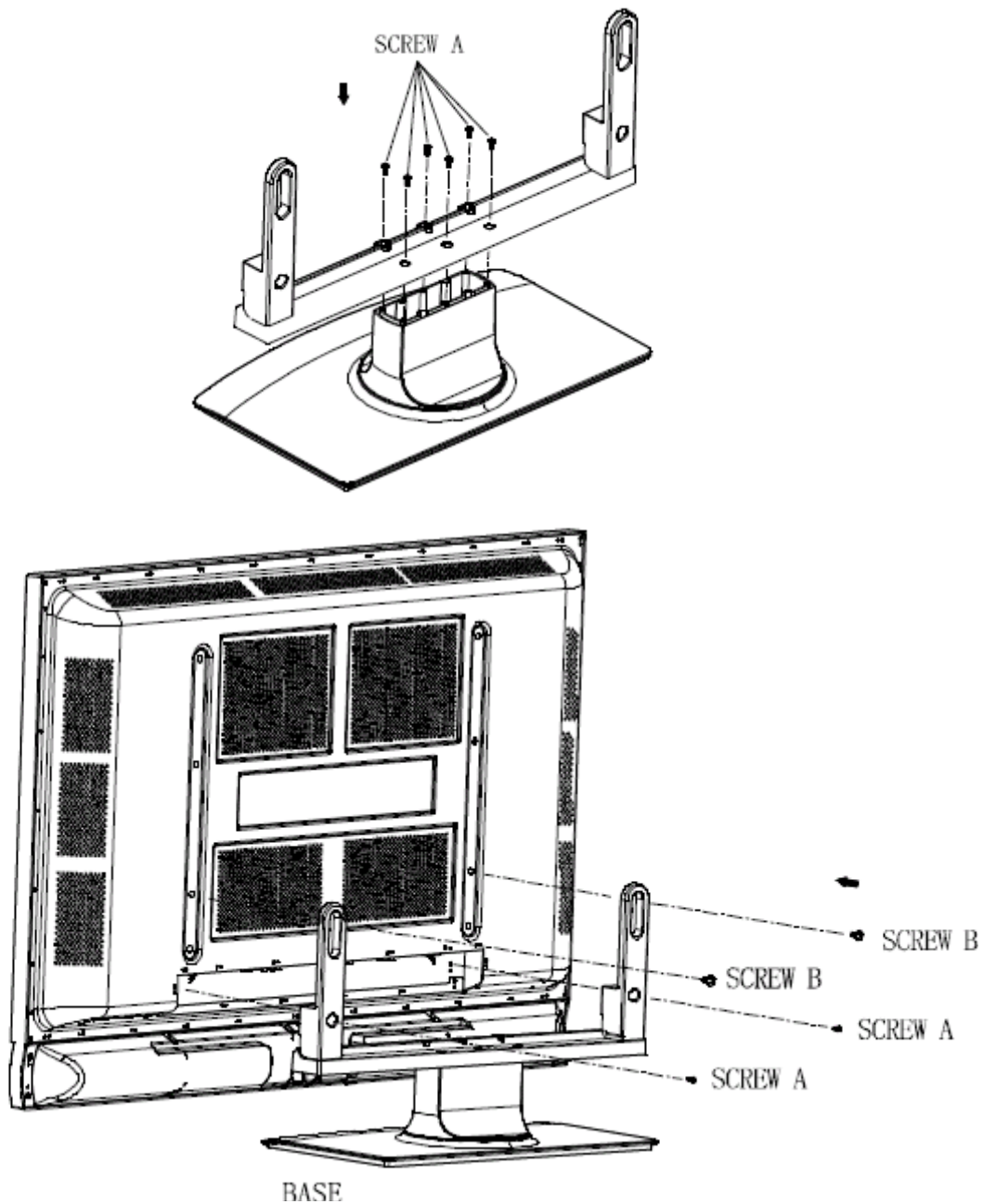

PDP Wall-mounting Bracket Installation Guide

**READ CAREFULLY BEFORE INSTALLATION!
THE INSTALLATION GUIDE SHOULD BE RETAINED FOR FUTURE REFERENCE.**

Caution:

1. Do NOT attempt to install the TV by yourself to avoid mistakes or hazard. Refer all installation to qualified servicing personnel.
2. Do NOT install the TV on a wall aslope or a wall that makes the TV screen sloping over 25°off plumb line. Otherwise, it may cause tumble or injury.
3. Refer all installation to qualified servicing personnel.

4. One must follow the instructions in this guide to correctly install the TV.
5. It requires more than one person to install the TV.
6. Before installation, examine whether the wall conforms to the specifications and whether the supplied parts can be fixed on it. The wall for mounting should sustain the weight of TV and speakers, e.g. cement wall or brick wall. Do NOT attempt to install the TV on a flexible wall such as sand wall or plaster wall, unless the bolt are fixed on an area with standard building rigidity which sustains the weight of the TV and speakers. If the rigidity of the wall can not be measured, every mounting hole should sustain a frontal force of over 100N and a shearing force of over 200N.
7. Use the specified electric drill and drill bit for drilling. The drilling holes should conform to the specifications.
8. To avoid fire and shock, do NOT place radiator, heater or humidifier below the installed TV.
9. The TV should be kept away from moisture, sensors and power line. The TV should be kept away from impact and vibration.
10. Ensure that the power supply be disconnected before installation for fear of fire and shock.
11. The max adjusting degree is 5°

Wall-mounting Installation Steps:

1. Take out the brackets from the package, and check if there are serious defects (e.g. infirm juncture).
2. Adjust the bracket to the desired angle. Use the bolts 2 to adjust the angle by meeting holes of column beam 8 and holes of lever 5
3. Drill locating holes in the specified dimension in a vertical wall of concrete or brick. The hole size should be 11mm. The hole depth should accommodate the expanding tube of the bolt.
4. Fix the bolts into the drilled holes in step3, and then cover each bolt with a metal washer. Meet the four mounting holes in the bracket with the four bolts in the wall, cover each bolt with a metal washer, and then fasten with a screw nut. Check its rigidity by pulling the bracket.
5. Take away the handles and the base from the back of TV;
6. Fix the fixture disk 4 to the back cover of the TV using four bolt 3(M8X45) .
7. Wall-mount the TV by putting the four fixture disks into the four mounting holes A.
8. If the customer is not satisfied with the mounting angle, take down the TV and adjust the angle before re-mounting.
9. After wall-mounting the TV, use bolts 2 to fix the fixture disks for fear of accidental slide.

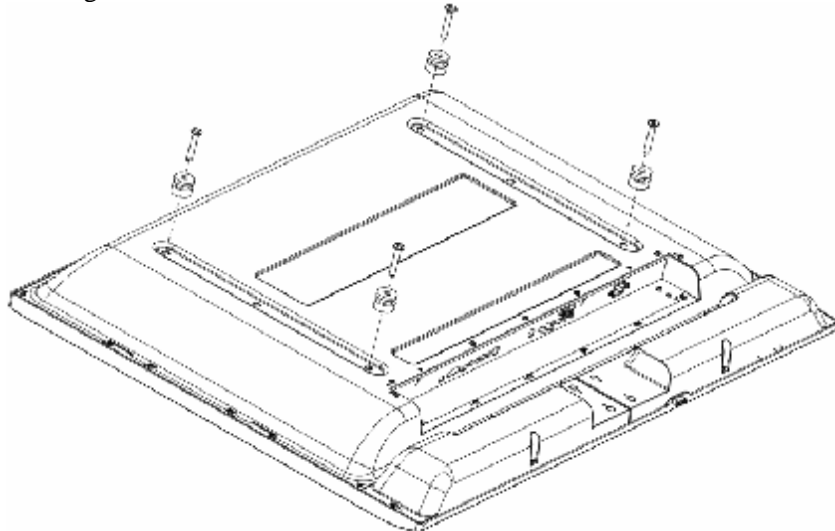

Wall-mounting Quick Guide

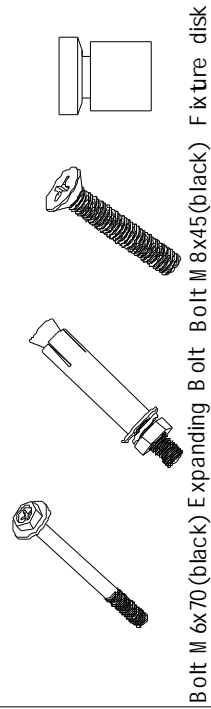
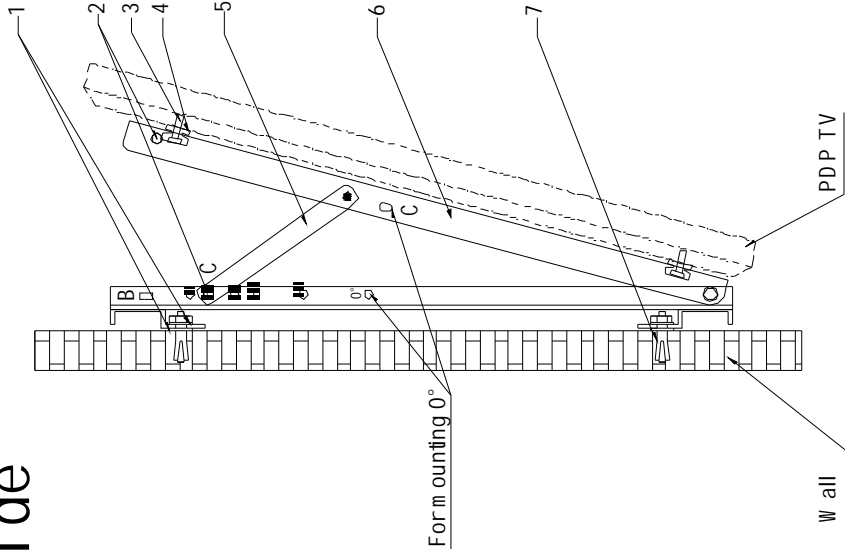
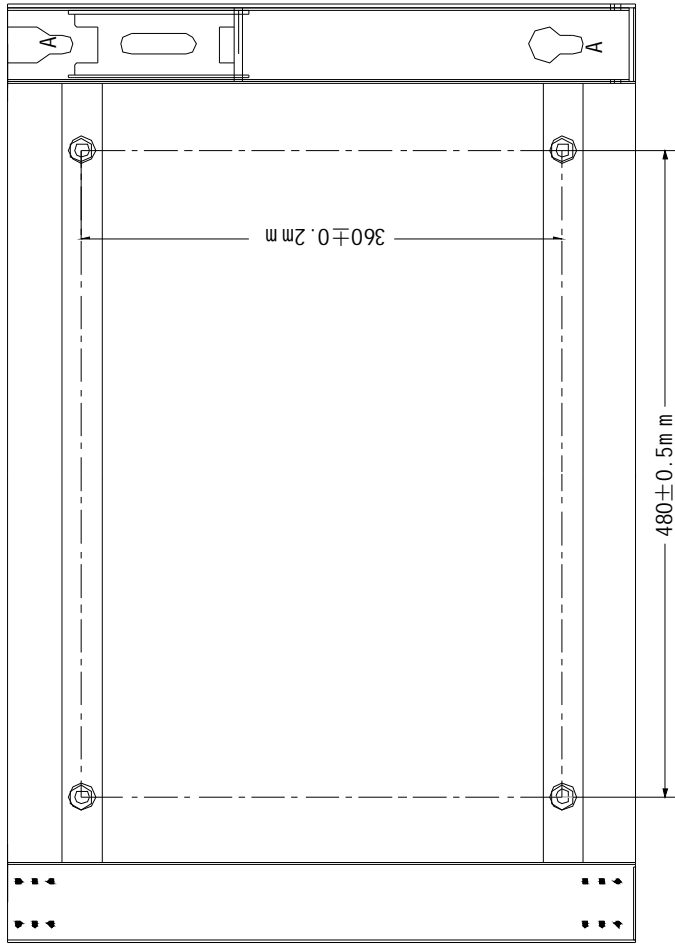

No.	name	Material	Quantity	No.	name	Material	Quantity
1	Plain Washer	Steel	8	5	Lever	Iron	2
2	Bolt M 6x70 (black)	Steel	4	6	Vertical Beam	Iron	2
3	Bolt M 8x45 (black)	Steel	4	7	Expanding Bolt	Steel	4
4	Fixture disk	Nylon	4				

Bolt M 6x70 (black) Expanding Bolt Bolt M 8x45 (black) Fixture disk

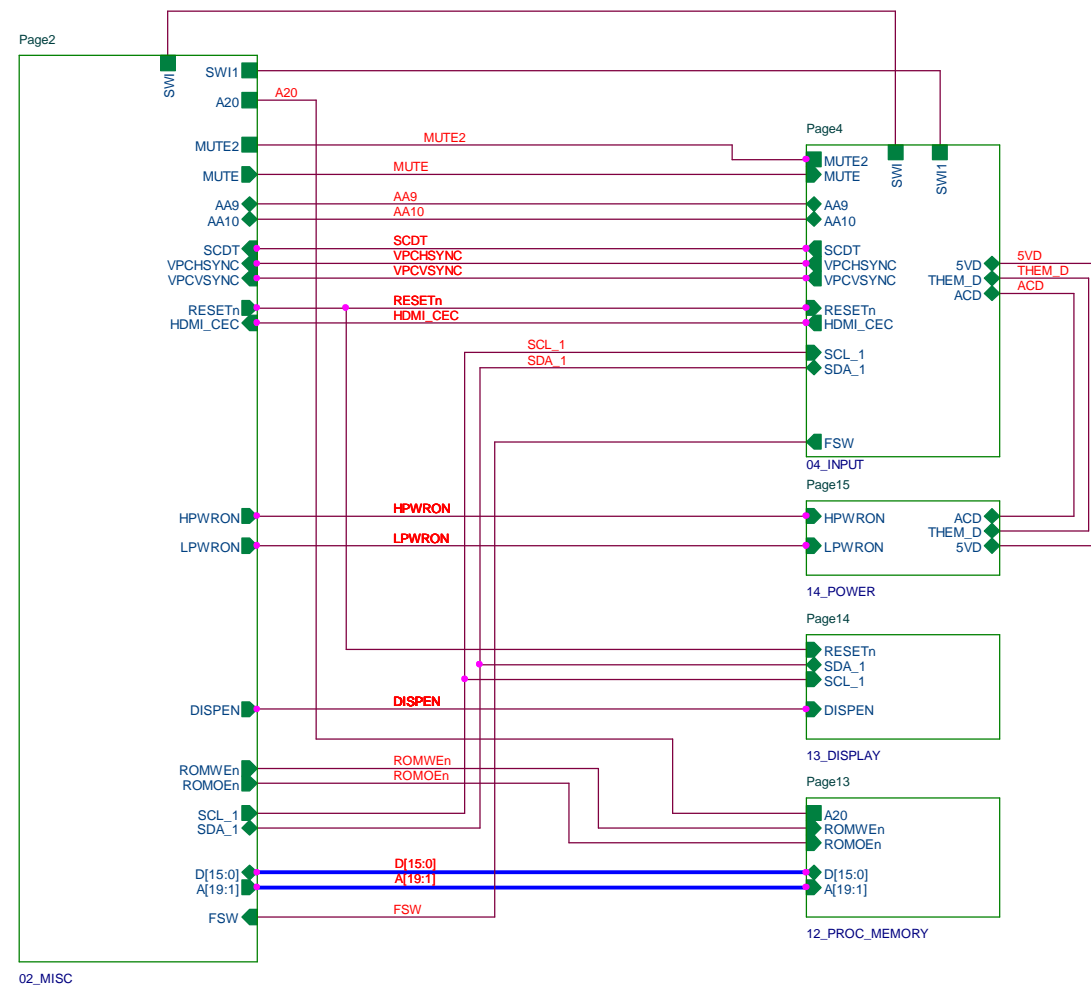

Page16
15_REVISION

Page3
03_MAIN_MEMORY

Pixelworks, Inc. Confidential		5020 Anzhen Plaza Beijing 100013, P.R.C (010)64482184	
Title Hisense PW318 - Top Level		Rev A	
Size A	Document Number HISENSE PHOTOPIA PROJECT		Rev A
Date: Wednesday, December 21, 2005	Sheet 1	of 16	

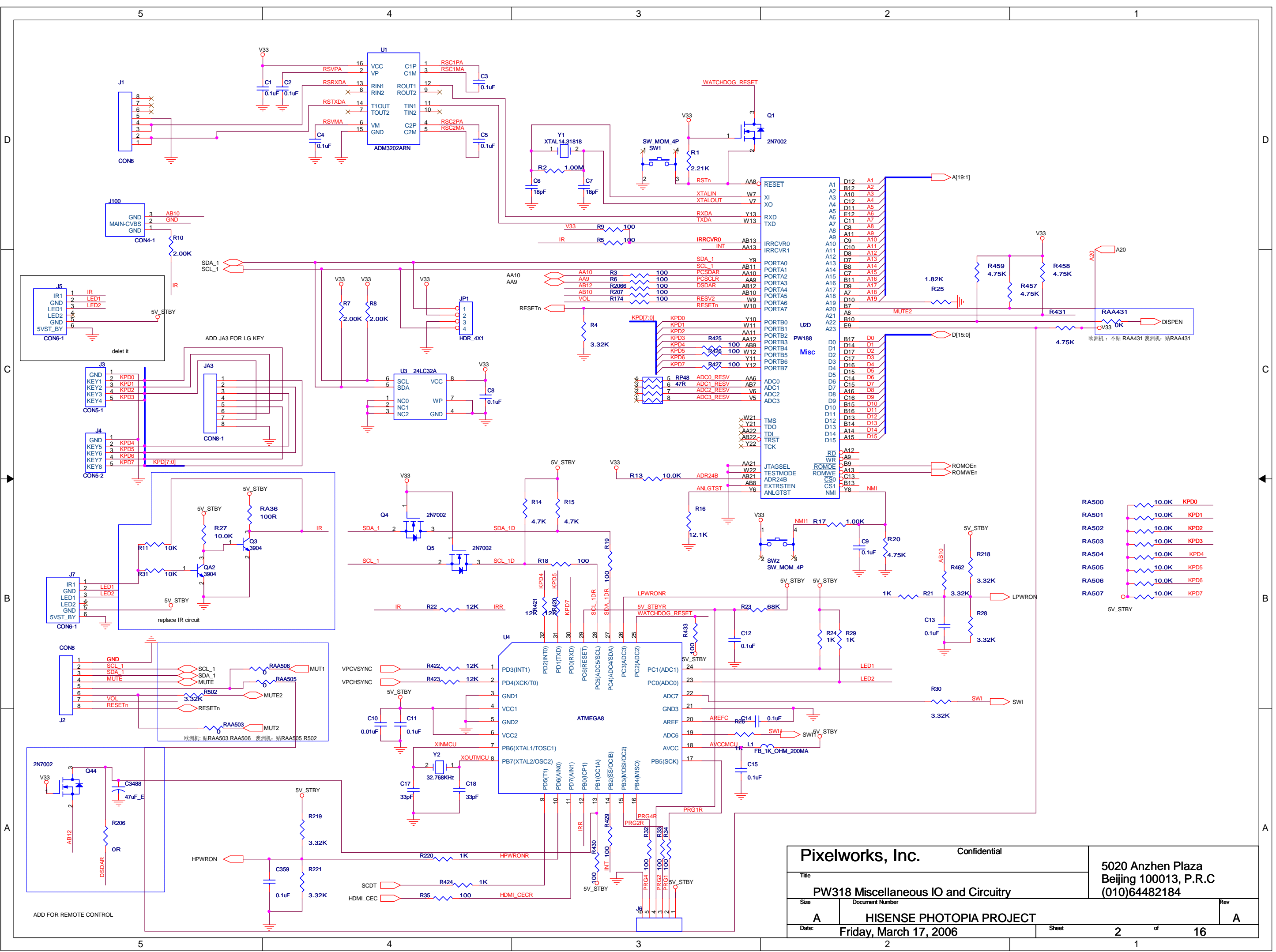

Pixelworks, Inc. Confidential		5020 Anzhen Plaza Beijing 100013, P.R.C (010)64482184	
Title PW318 Miscellaneous IO and Circuitry		Rev A	
Size A	Document Number HISENSE PHOTOPIA PROJECT		
Date: Friday, March 17, 2006	Sheet 2	of 16	

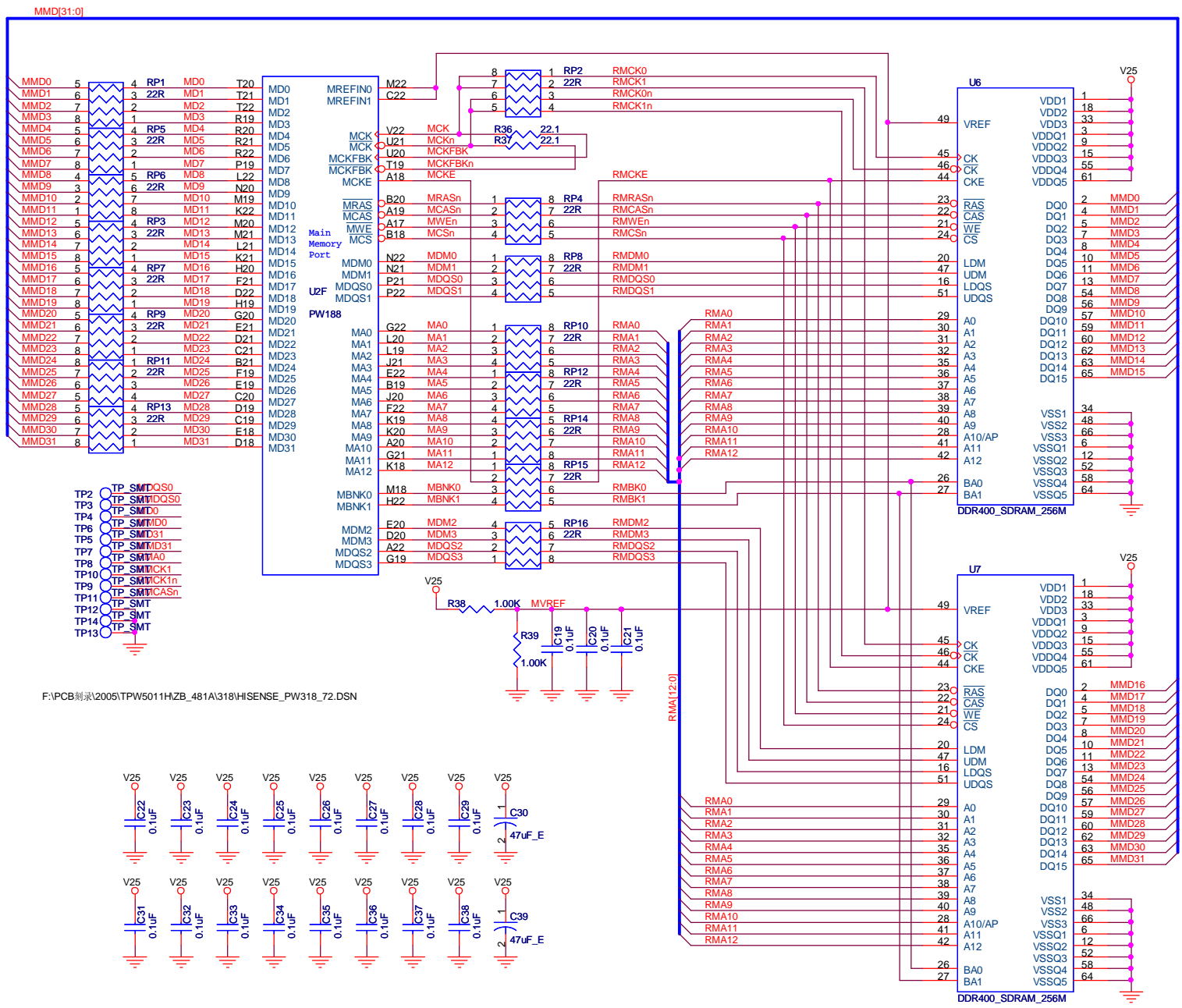

F:\PCB\2005\TPW5011HZB_481A\318\HISENSE_PW318_72.DSN

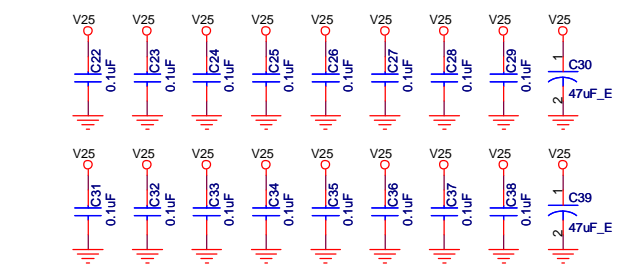

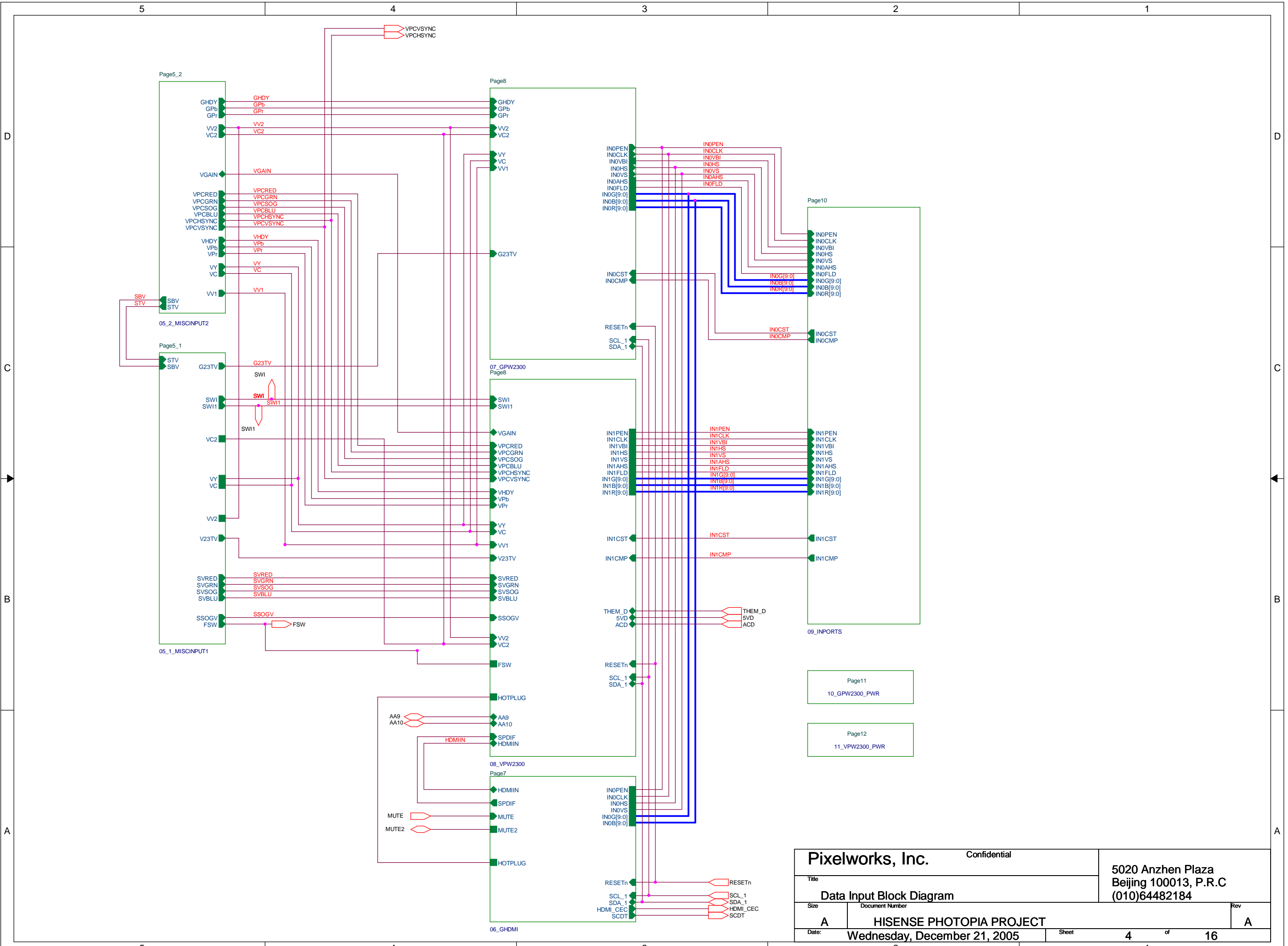

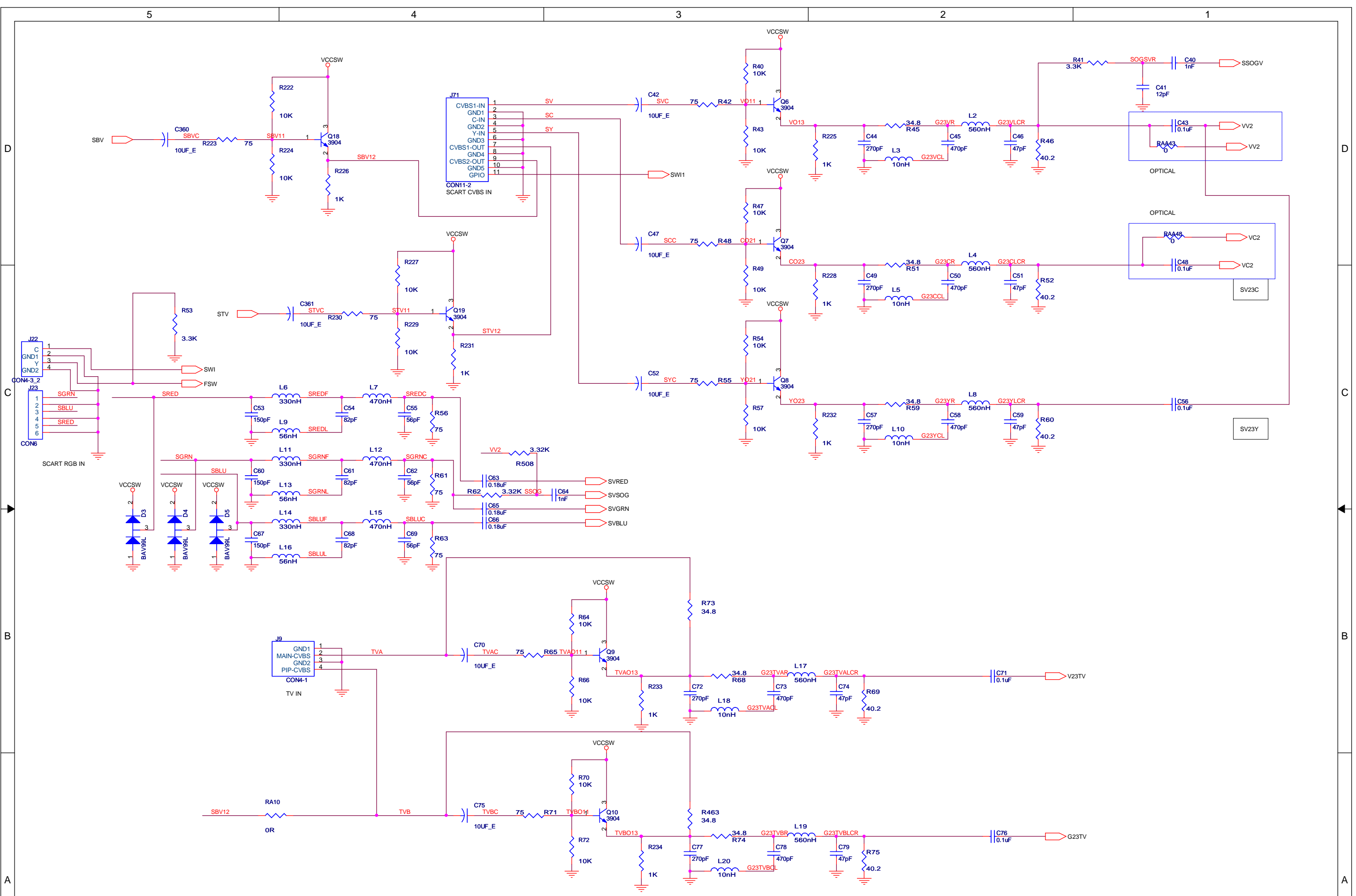

Pixelworks, Inc.		Confidential	
Title		5020 Anzhen Plaza Beijing 100013, P.R.C (010)64482184	
Size	Document Number		Rev
A	HISENSE PHOTOPIA PROJECT		A
Date:	Friday, March 17, 2006	Sheet	5 of 16

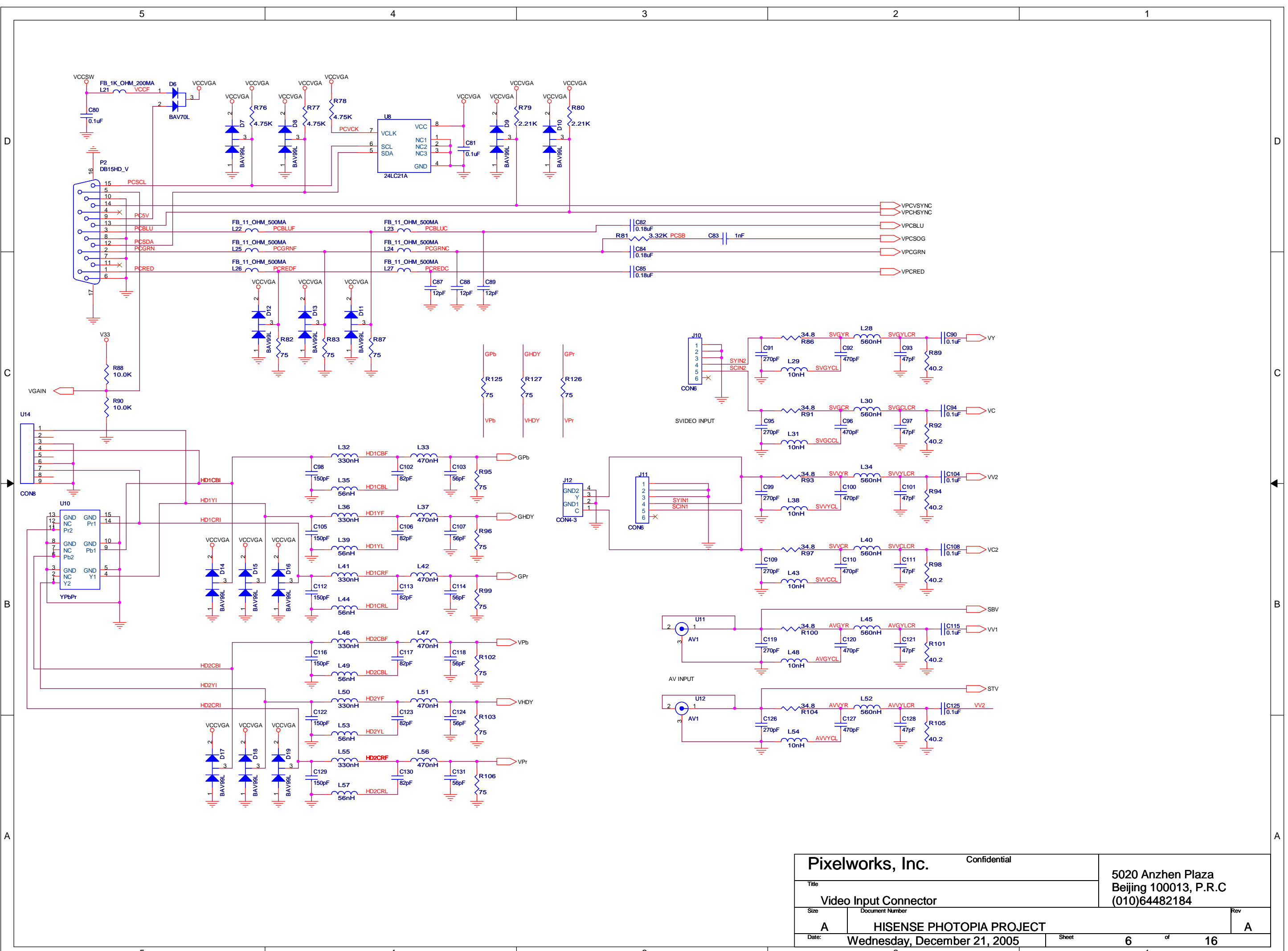

Pixelworks, Inc.		Confidential	
Title		5020 Anzhen Plaza Beijing 100013, P.R.C (010)64482184	
Size	Document Number		Rev
A	HISENSE PHOTOPIA PROJECT		A
Date:	Wednesday, December 21, 2005	Sheet	6 of 16

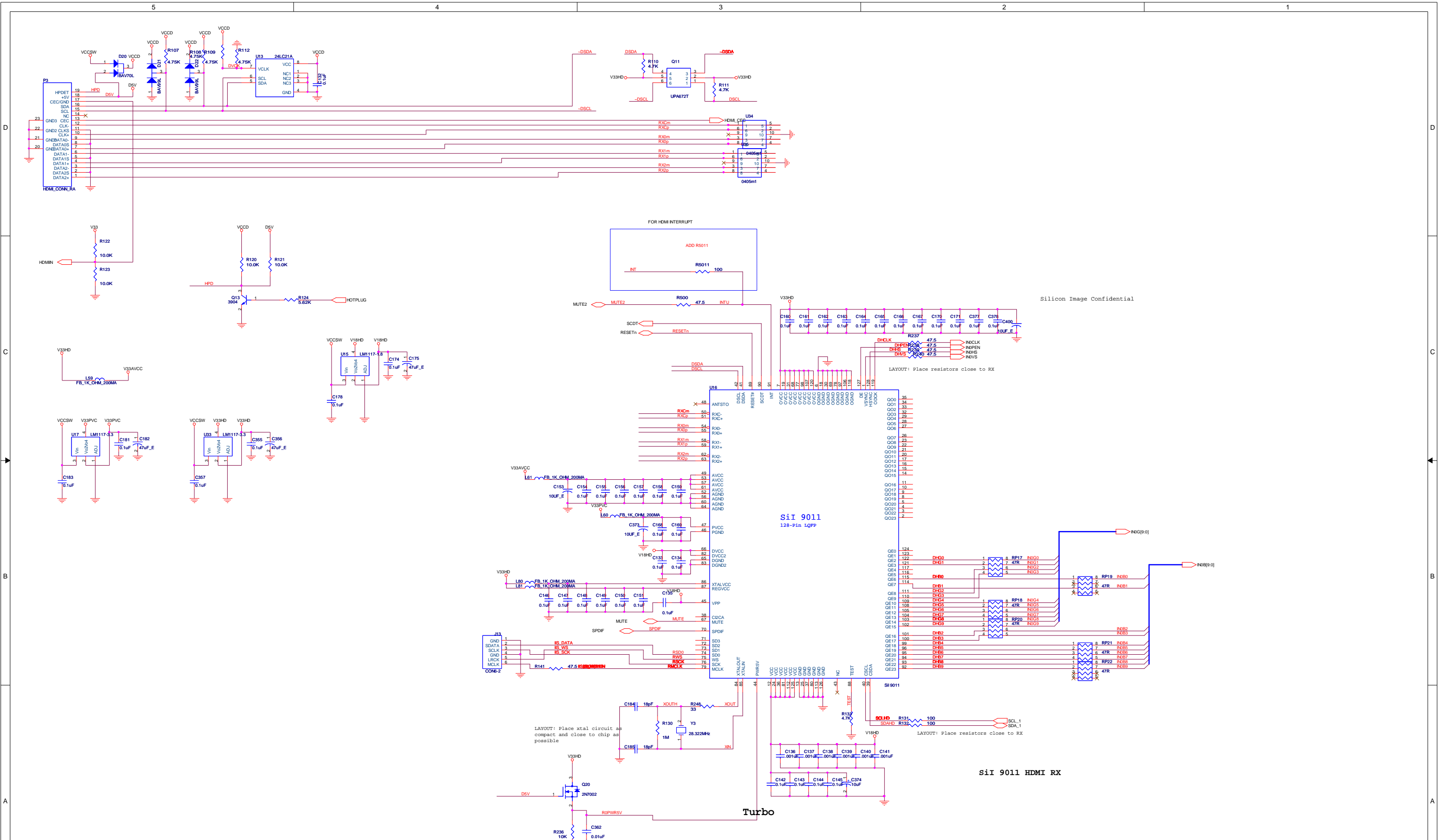

Silicon Image Confidential

SiI 9011
128-Pin LQFP

SiI 9011 HDMI RX

Pixelworks, Inc. Confidential		5020 Anzhen Plaza Beijing 100013, P.R.C (010)64482184	
HDMI Connector, DDC EEPROM, and ESD Filters			
Size	Document Number	Rev	
B	HISENSE PHOTOPIA PROJECT	A	
Date:	Wednesday, December 21, 2005	Sheet	7 of 16

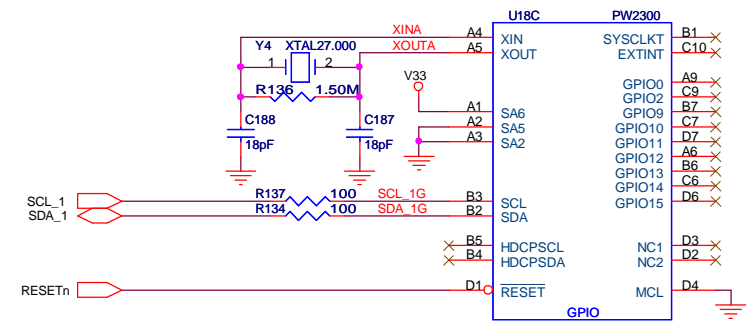
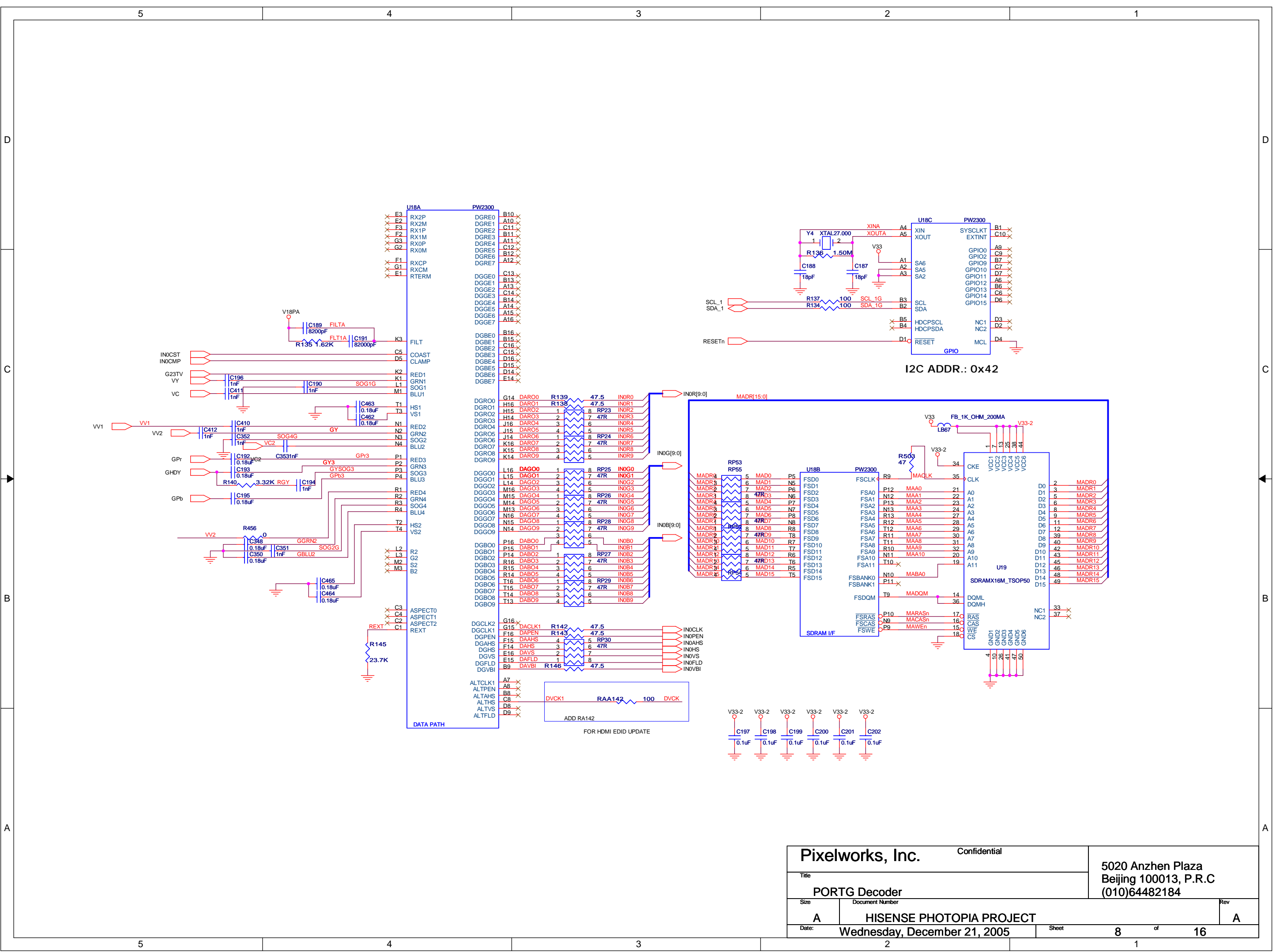

I2C ADDR.: 0x42

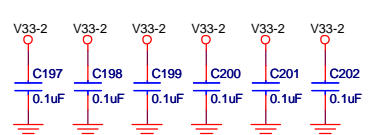
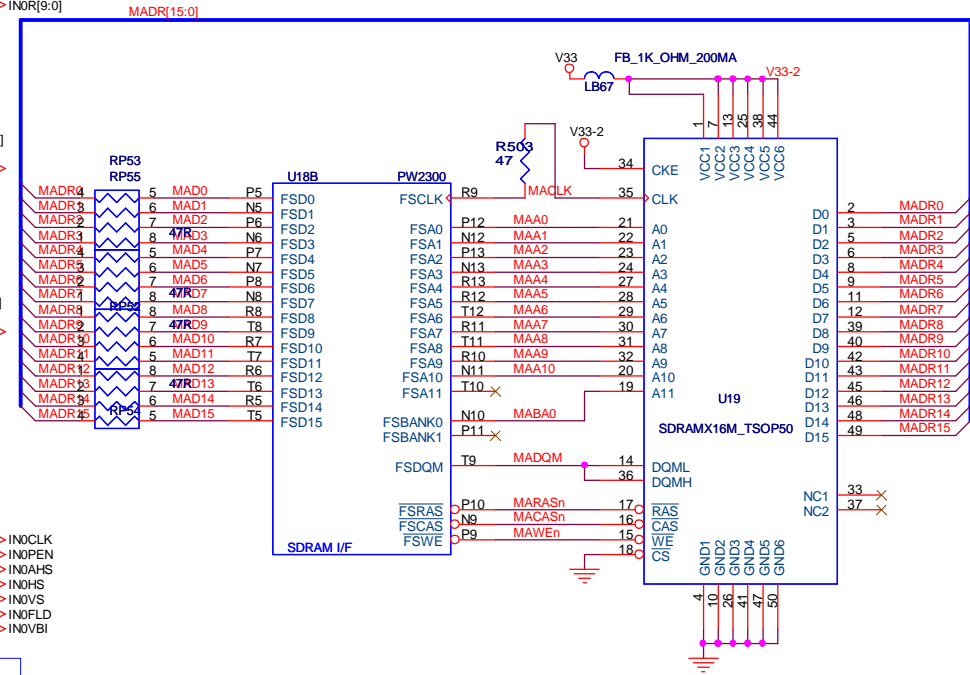

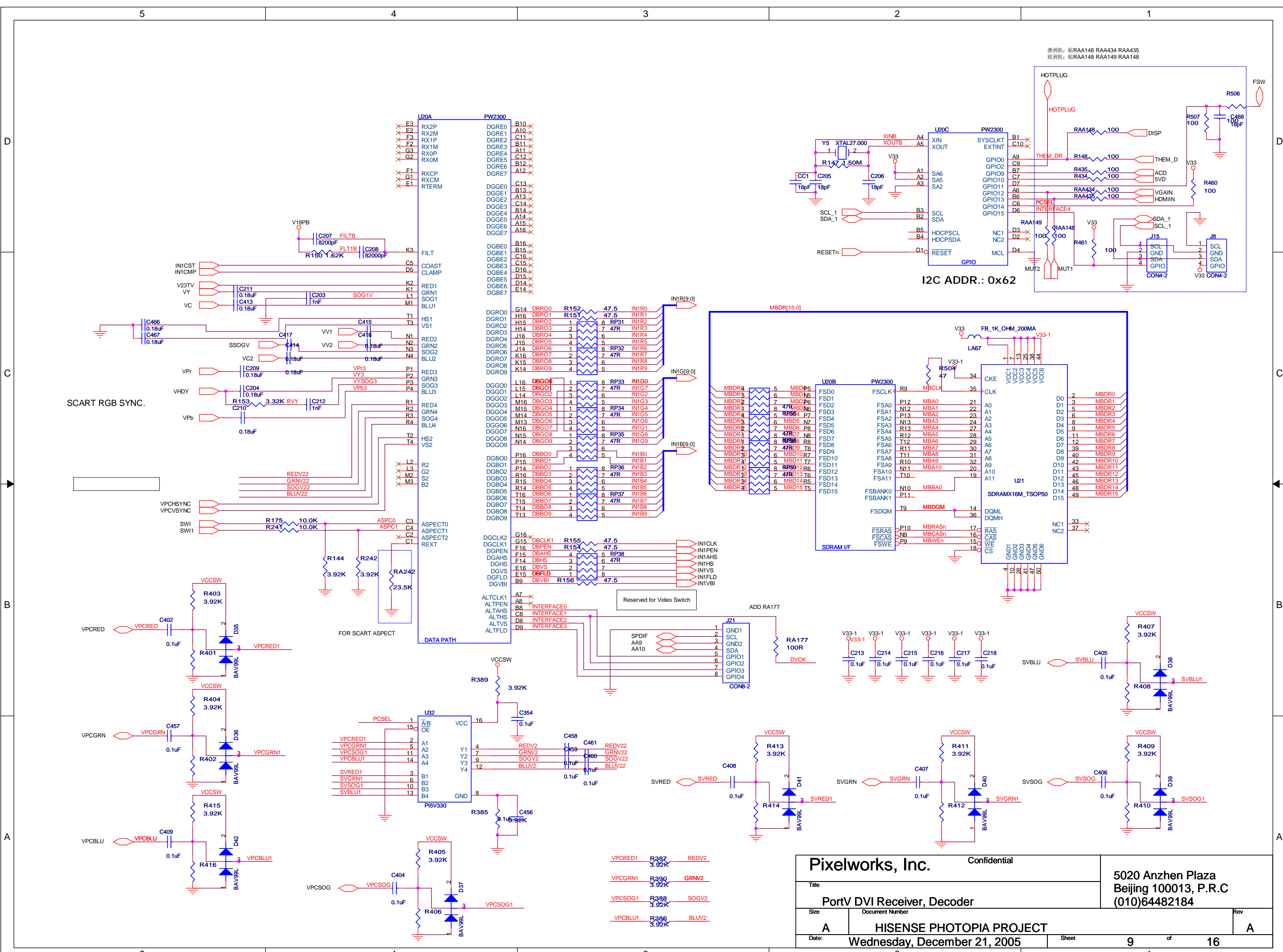

Pixelworks, Inc. Confidential		5020 Anzhen Plaza Beijing 100013, P.R.C (010)64482184	
Title Port V DVI Receiver, Decoder			
Size A	Document Number HISENSE PHOTOPIA PROJECT		Rev A
Date Wednesday, December 21, 2005	Sheet 9	of 16	

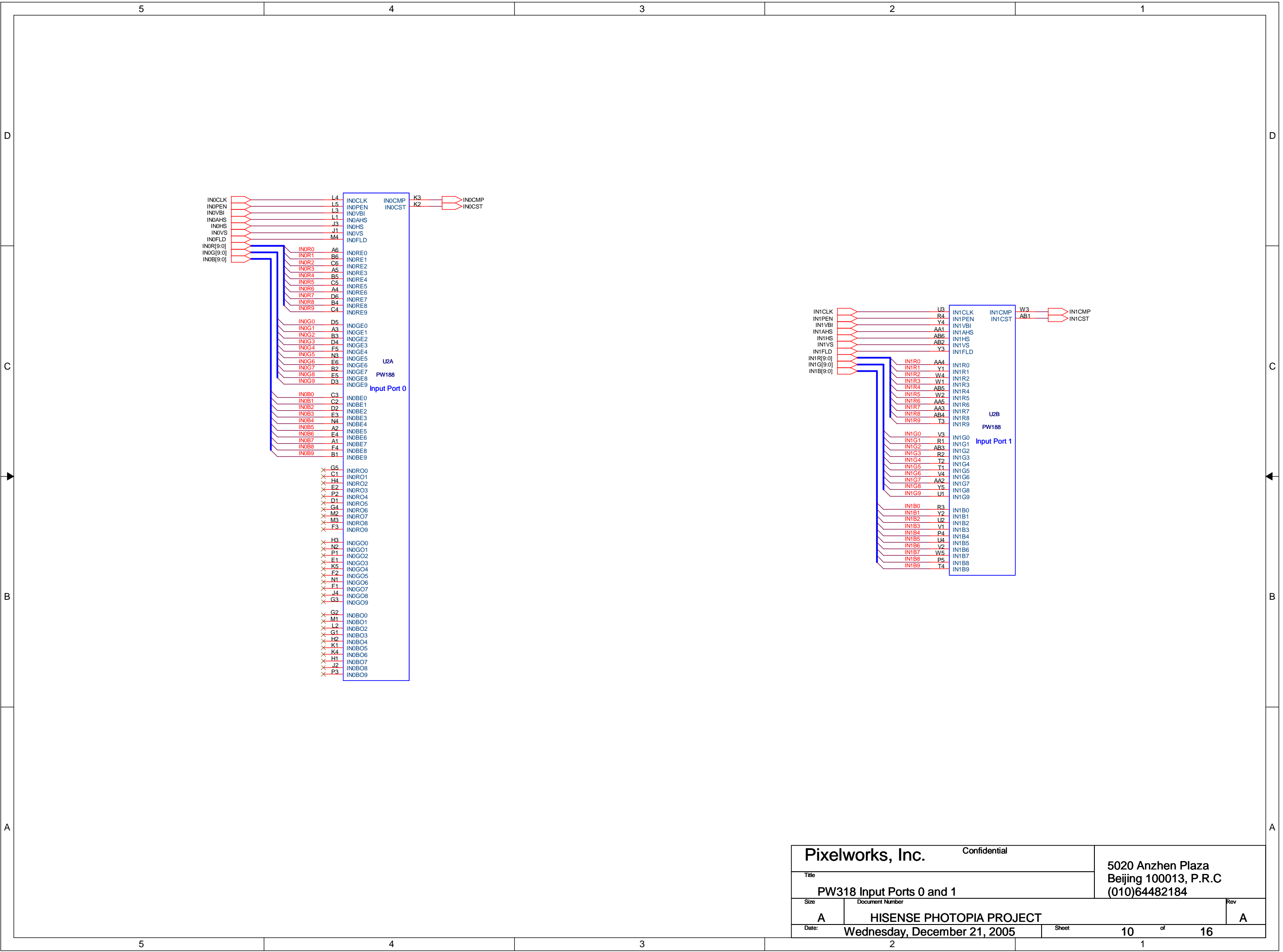

Pixelworks, Inc. Confidential		5020 Anzhen Plaza Beijing 100013, P.R.C (010)64482184	
Title PW318 Input Ports 0 and 1		Rev A	
Size A	Document Number HISENSE PHOTOPIA PROJECT		Date Wednesday, December 21, 2005
Date		Sheet 10	of 16

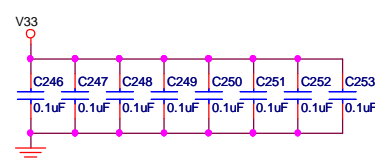
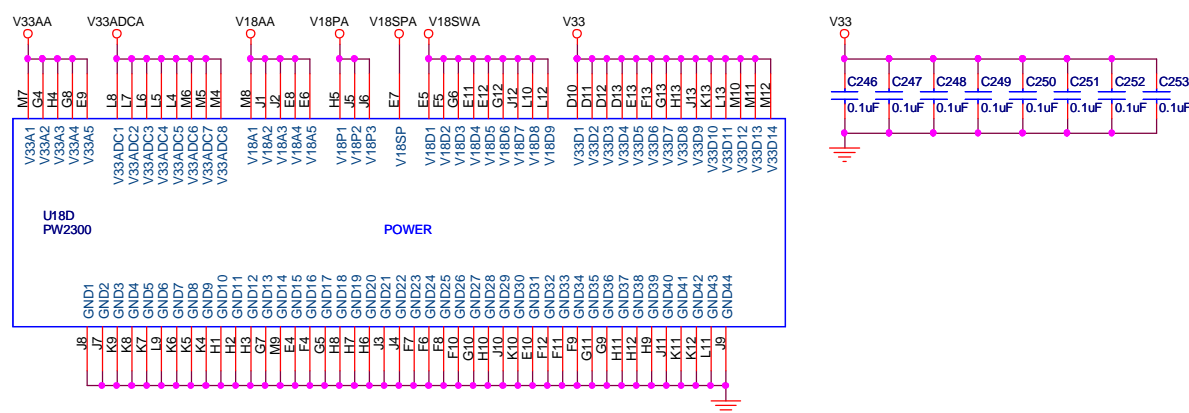
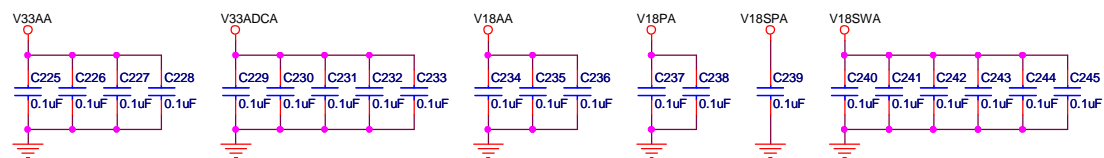
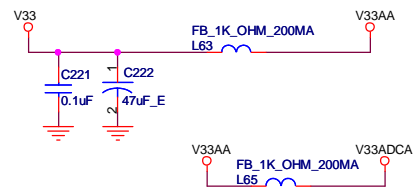
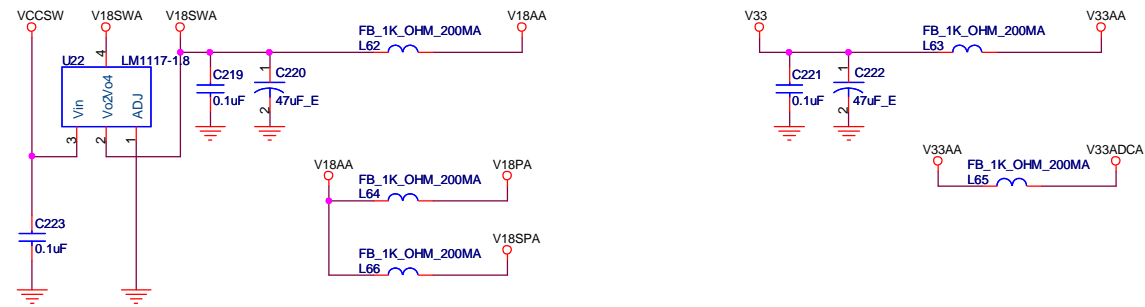

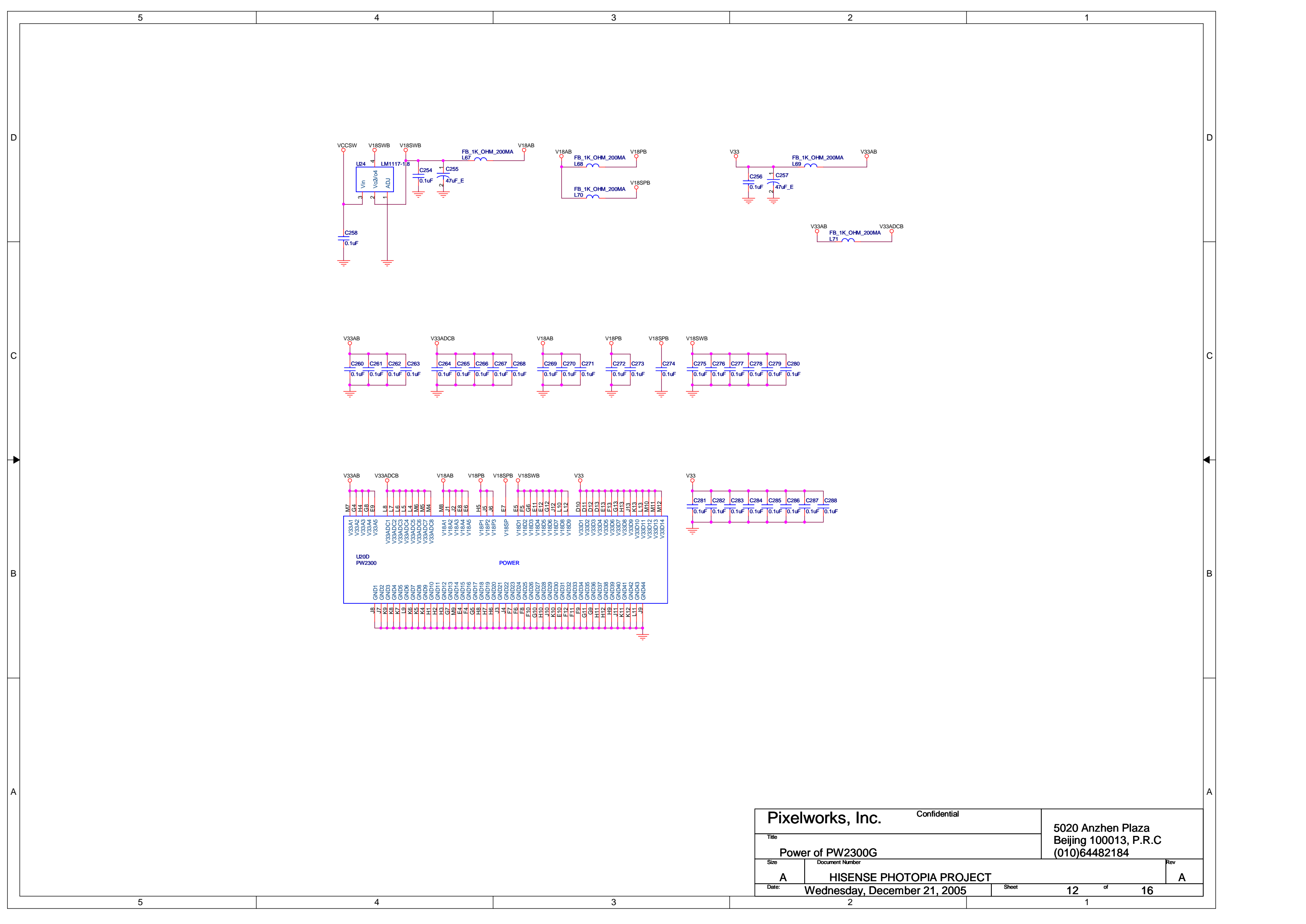

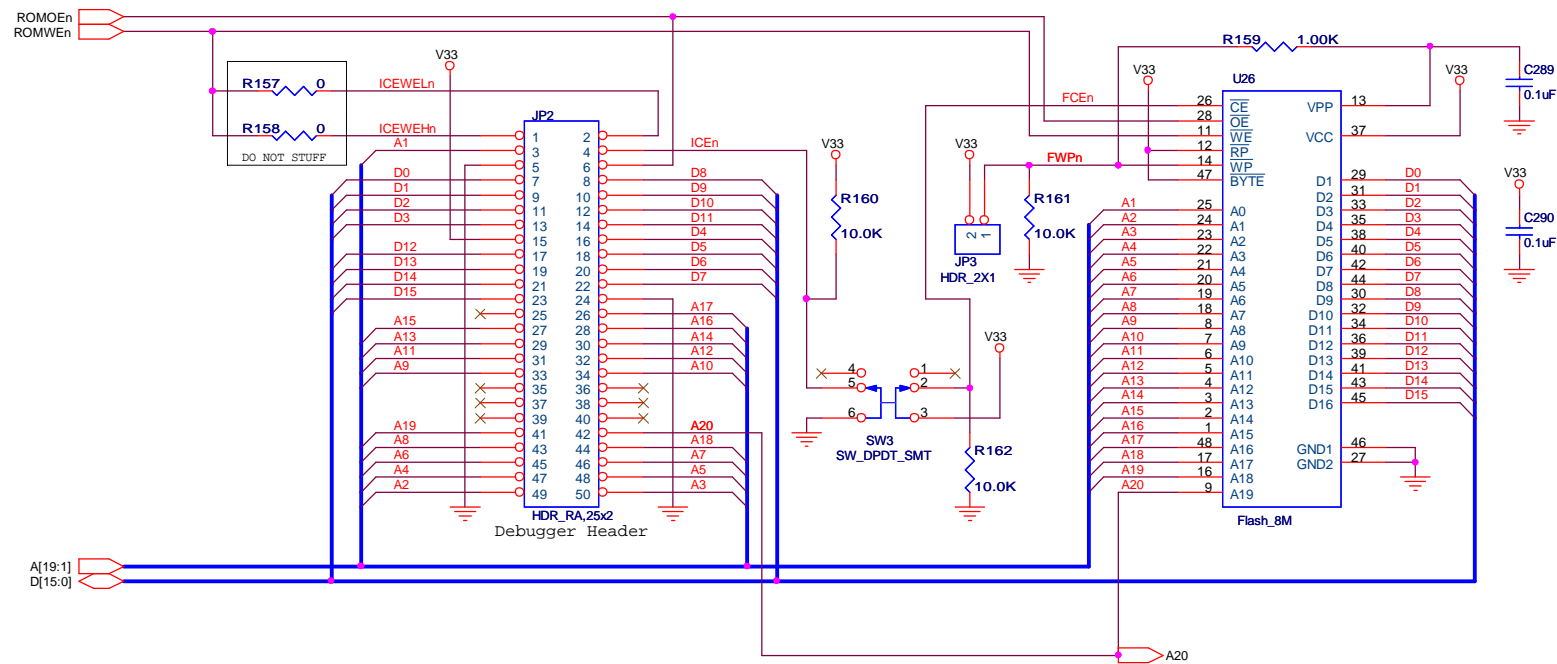

Pixelworks, Inc. Confidential		5020 Anzhen Plaza Beijing 100013, P.R.C (010)64482184	
Title		Rev	
Debug Header and Flash		A	
Size	Document Number	Date	
A	HISENSE PHOTOPIA PROJECT	Wednesday, December 21, 2005	
Date		Sheet	13 of 16

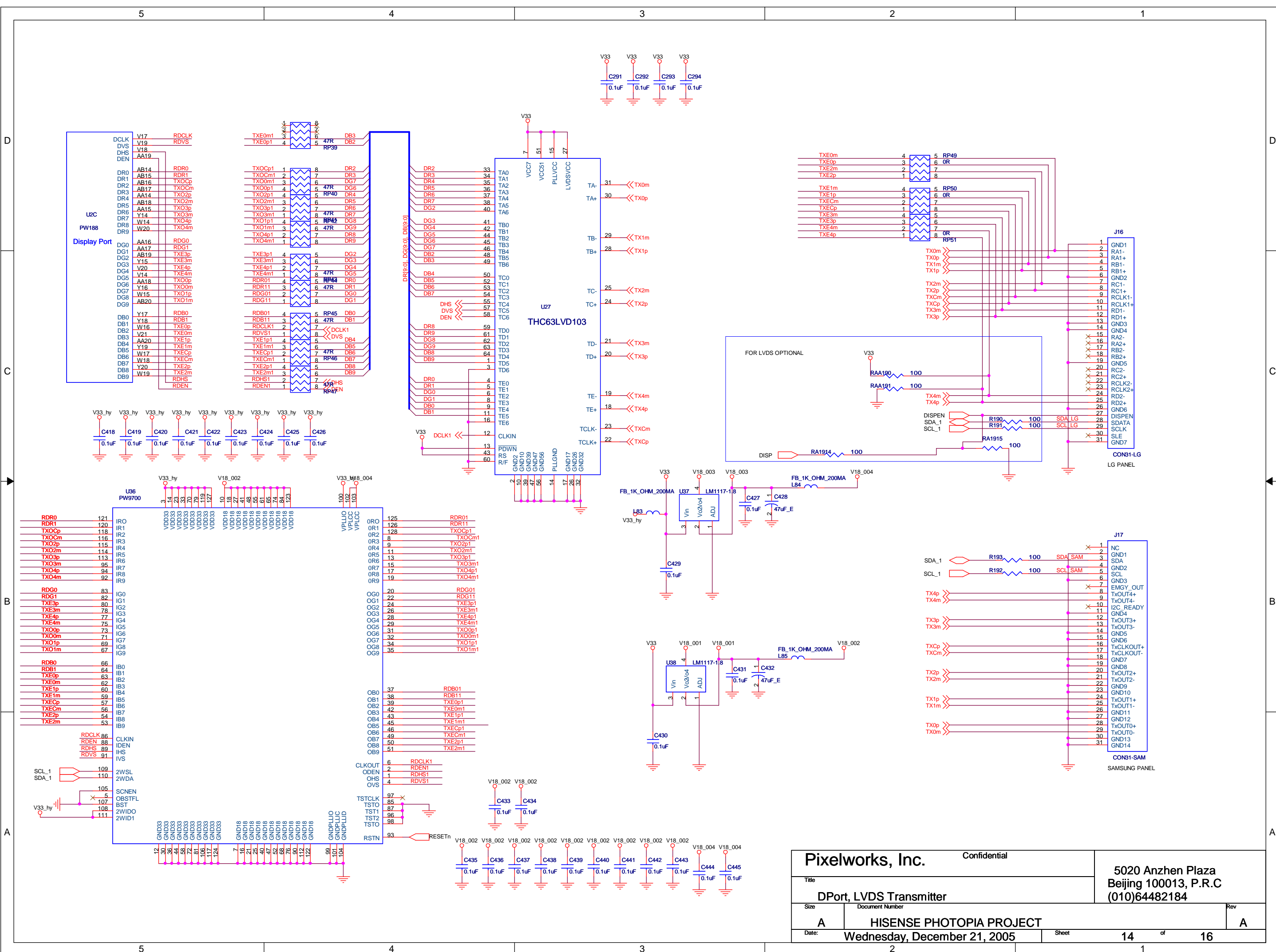

Pixelworks, Inc. Confidential		5020 Anzhen Plaza Beijing 100013, P.R.C (010)64482184	
Title DPort, LVDS Transmitter		Rev A	
Size A	Document Number HISENSE PHOTOPIA PROJECT	Date Wednesday, December 21, 2005	Sheet 14 of 16

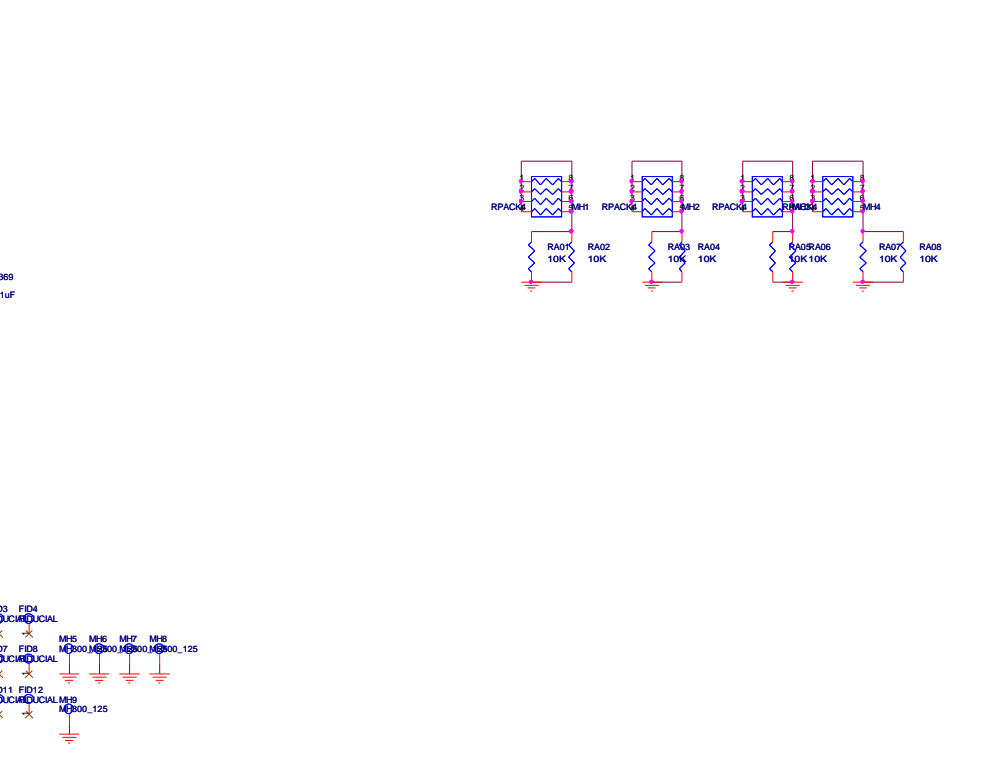
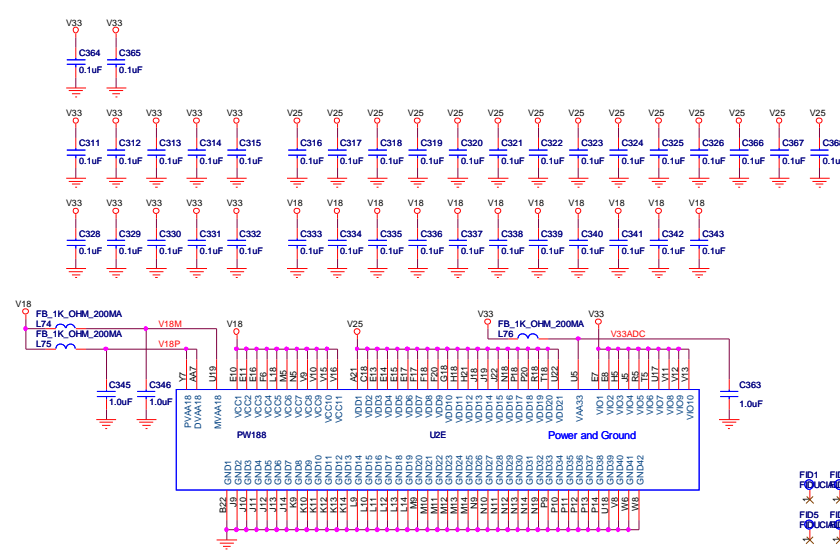
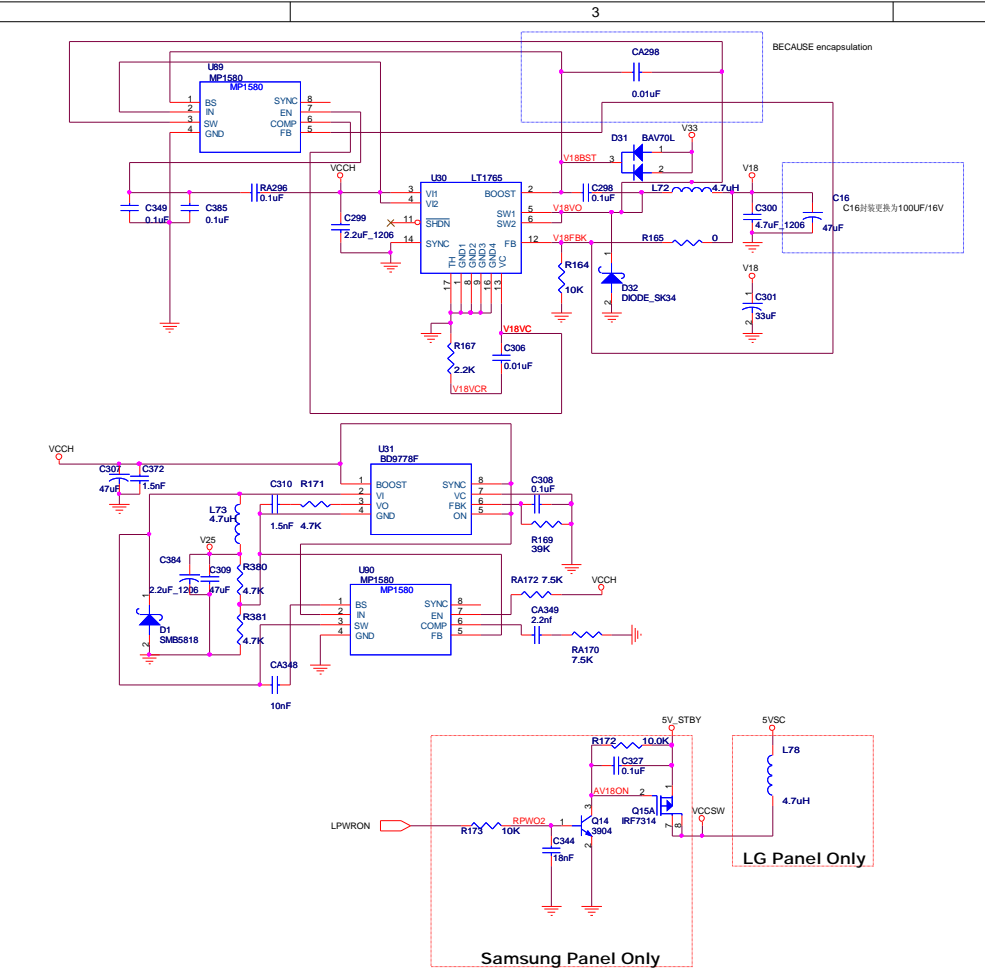
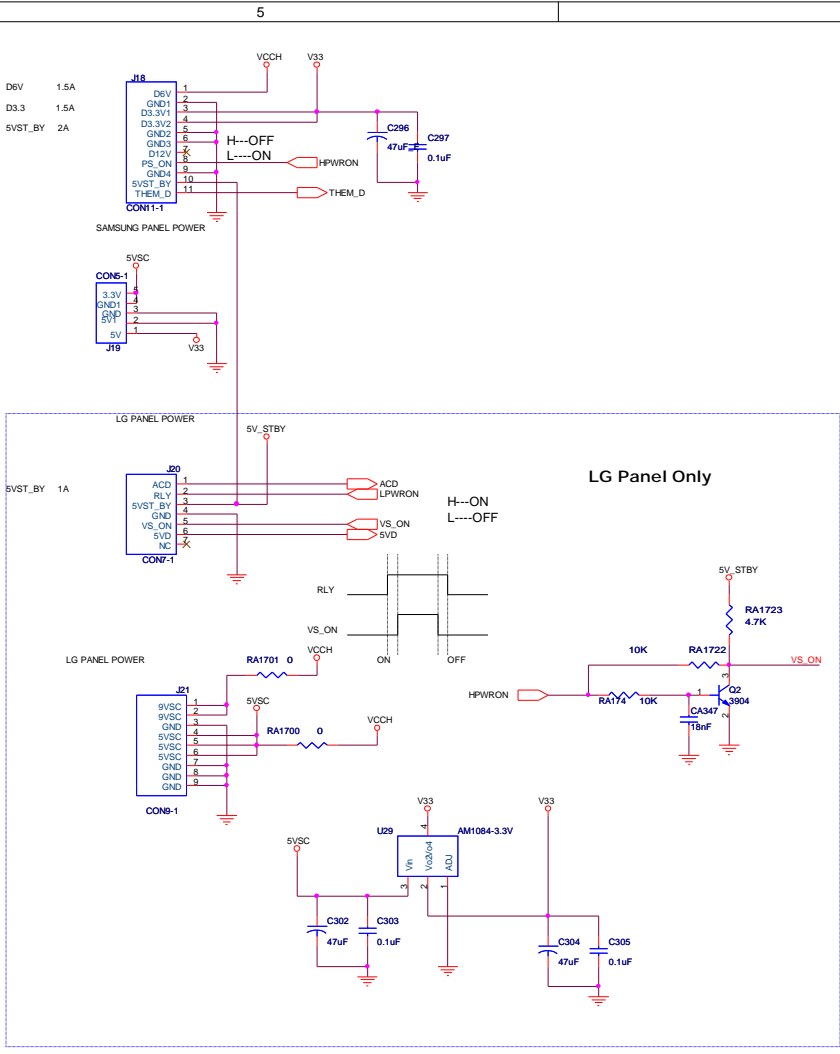

Pixelworks, Inc. Confidential		5020 Anzhen Plaza Beijing 100013, P.R.C (010)64482184	
Regulators and PW318 Capacitors			
Rev	Document Number		Rev
B	HISENSE PHOTOPIA PROJECT	Sheet	A
Date:	Sunday, March 05, 2006	15	of 16

REV.	DATE	ECN NUMBER	DESCRIPTION OF CHANGE
00 -A	9-23-04	NA	Initial version.

D

D

C

C

B

B

A

A

Pixelworks, Inc.		Confidential	
Title		5020 Anzhen Plaza Beijing 100013, P.R.C (010)64482184	
Revision History			
Size	Document Number		Rev
A	HISENSE PHOTOPIA PROJECT		A
Date:	Wednesday, December 21, 2005	Sheet	16 of 16

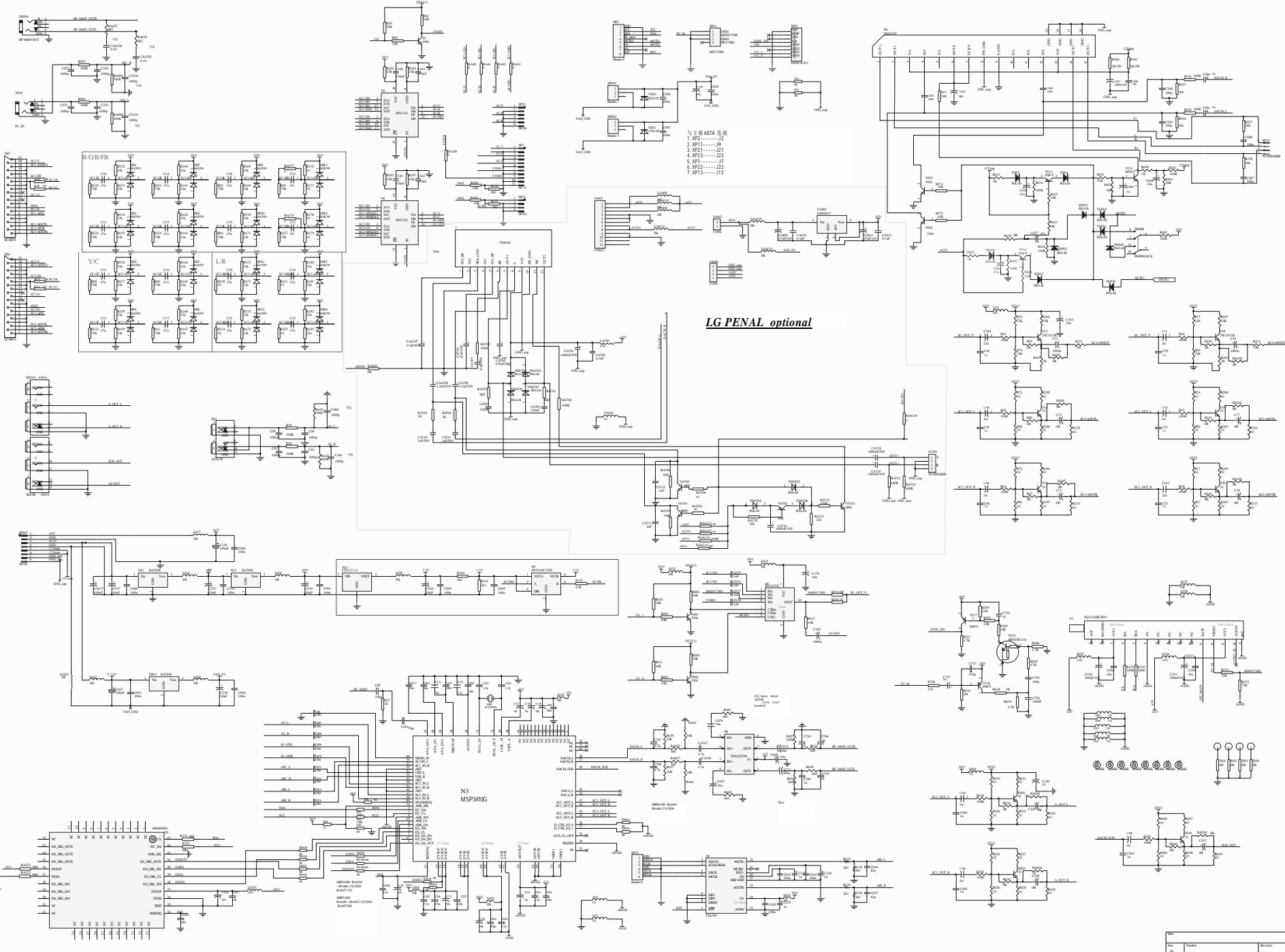

Rev.	Number	Revision
1		