

### PARTS INCLUDED • PIÈCES INCLUSES • PIEZAS INCLUIDAS

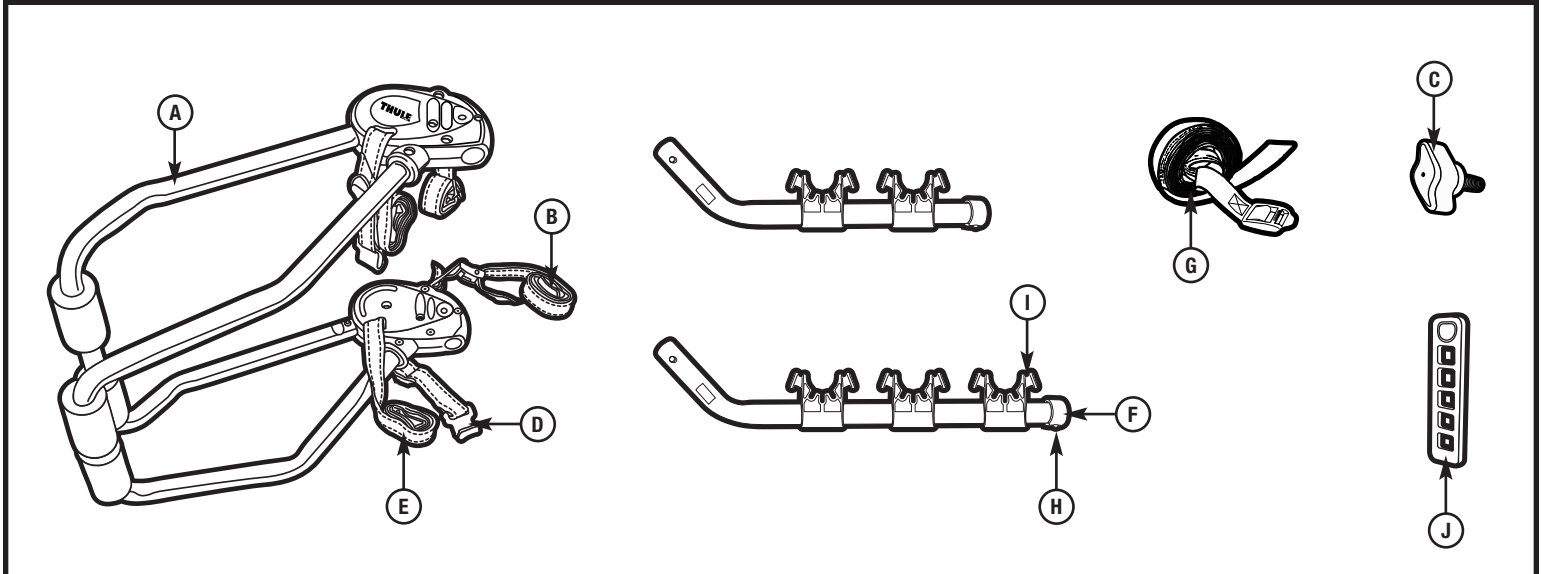

part pièce parte	description description descripción	part number numéro de pièce numero de parte	910 qty. 910 qté 910 cant.	911 qty. 911 qté 911 cant.
A	910/911 2 or 3 bike carrier / Porte-vélos pour 2 ou 3 vélos 910/911 / portabicicletas 910/911 para 2 o 3 bicicletas	—	1	1
B	top strap assembly / courroie supérieure / conjunto de correa superior	753-2184	2	2
C	2 wing adjustment knob / bouton d'ajustement à 2 ailettes / 2 perillas de ajuste con orejetas	753-3095	2	2
D	slide hook assembly w/ buckle / crochet coulissant avec boucle / conjunto de gancho deslizante con hebilla	753-2877	2	2
E	bottom strap (narrow) w/ buckle / courroie inférieure (étroite) avec boucle / correa inferior (angosta) con hebilla	753-0035-07	2	2
F	end cap / capuchon d'extrémité / tapón	853-2181	2	2
G	tie down strap / courroie avec boucle / apriete la correa	753-1492	1	1
H	screw / vis / tornillo	925-0613-11	2	2
I	cradle body / berceau / cuerpo del soporte	853-2568	4	6
J	cradle strap / courroie de berceau / correa del soporte	853-2569	4	6

### WARNINGS / LIMITATIONS • AVERTISSEMENTS/LIMITATIONS • ADVERTENCIAS / LIMITACIONES

- Number of bicycles carried should not exceed designated carrying capacity for your specific Passage model.
  - 910 (2 bike) max carrying capacity = 70lbs.
  - 911 (3 bike) max carrying capacity = 105lbs.
  - Check tightness of all bolts and knobs periodically.
  - Check straps for wear and replace if worn.
  - Not intended for off-road use.
  - Not intended for tandems or recumbents.
  - Do not install on a trailer or other towed vehicle.
  - Failure to use blue safety strap may result in loss of bicycles.
- Le nombre de vélos transportés ne doit pas dépasser la capacité de transport de votre modèle de porte-vélos Passage.
  - Capacité de transport maxi du 910 (2 vélos) = 32 kg (70 livres).
  - Capacité de transport maxi du 911 (2 vélos) = 43 kg (105 livres).
  - Vérifiez régulièrement le serrage de toutes les vis et des écrous.
  - Vérifiez l'usure des sangles et remplacez-les si elles sont usées.
  - N'est pas prévu pour une utilisation tout-terrain.
  - N'est pas prévu pour les tandems ni les vélos à position allongée (VPA).
  - Ne l'installez pas sur une remorque ou un véhicule remorqué.
  - L'absence d'utilisation de la sangle sécurité bleue peut entraîner la perte de vélos.
- La cantidad de bicicletas transportadas no debe superar la capacidad de carga designada para su modelo específico de Passage.
  - Capacidad máxima de carga del 910 (2 bicicletas) = 32kg (70 libras).
  - Capacidad máxima de carga del 911 (2 bicicletas) = 43kg (105 libras).
  - Comprobar periódicamente que todos los pernos y perillas estén bien apretados.
  - Revisar el estado de las correas y reemplazarlas si están desgastadas.
  - No está diseñado para tandems ni bicicletas reclinadas.
  - No destinado para el uso todoterreno.
  - No instalar en un trailer ni otro vehículo a remolque.
  - Si no se usa la correa de seguridad azul, se puede perder alguna de las bicicletas.

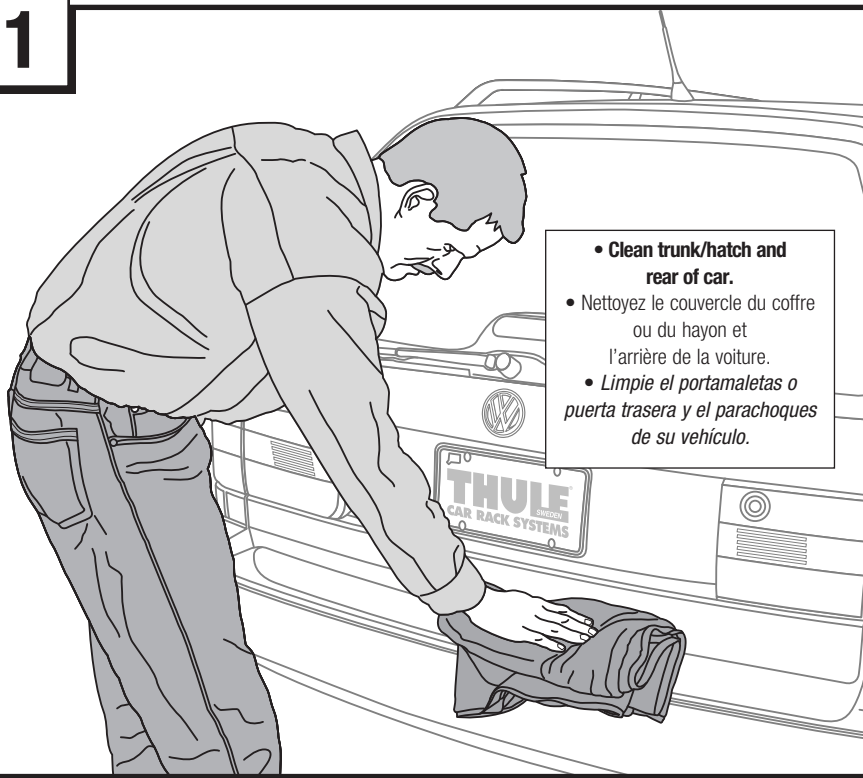
**1**

- Clean trunk/hatch and rear of car.
- Nettoyez le couvercle du coffre ou du hayon et l'arrière de la voiture.
- Limpie el portamaletas o puerta trasera y el parachoques de su vehículo.

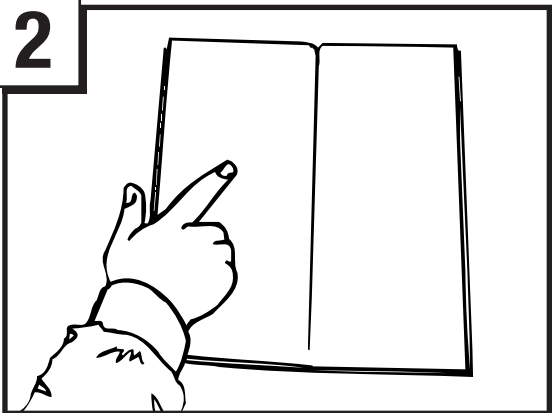
**2**

- Look up your vehicle in the Fit Guide (included with these instructions) for recommended fit number. **BE SURE TO READ THE FIT TIPS THAT APPLY TO YOUR VEHICLE.**  
Recherchez votre véhicule dans le guide de réglage (accompagnant ces instructions) pour le numéro de réglage recommandé. **VEILLEZ À LIRE LES CONSEILS DE RÉGLAGE QUI S'APPLIQUENT À VOTRE VÉHICULE.**  
*Busque el número de ajuste recomendado para su vehículo en la Guía de Ajuste que se incluye con estas instrucciones. ASEGÚRESE DE LEER LOS CONSEJOS DE AJUSTE QUE APLICAN A SU VEHÍCULO.*

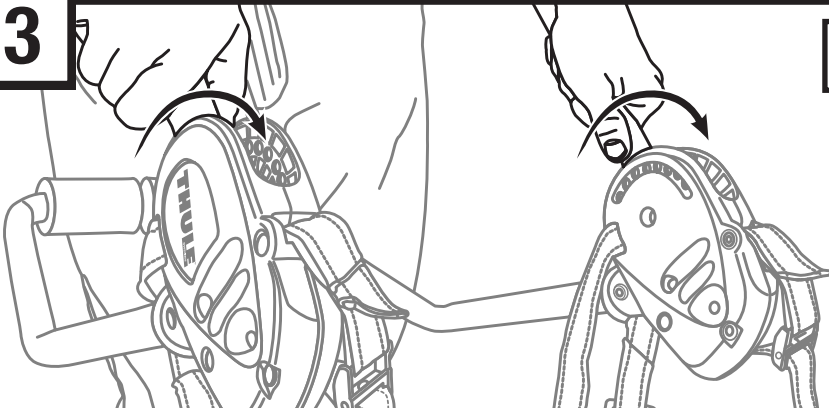
**3****a**

- Remove both 2 Wing Adjustment Knobs and adjust to correct fit numbers.  
Retirez les deux écrous de réglage à 2 ailettes et serrez et ajustez aux numéros de réglage corrects.  
*Saque ambas perillas de ajuste de 2 alas y gradúe a los números de ajuste correctos.*

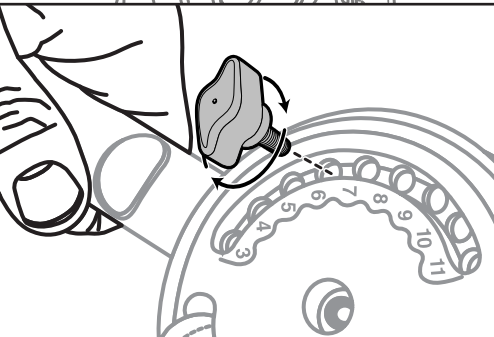
**b**

- Insert both 2 Wing Adjustment Knobs and tighten until knobs are fully seated against fit dial. **Be careful not to cross thread.**  
Introduisez les deux écrous à ailettes et serrez jusqu'à ce que les écrous soient complètement contre le cadran de réglage. Veillez à ne pas fausser le filetage.  
*Introduzca ambas perillas de ajuste de 2 alas y apriete hasta que las perillas estén completamente asentadas contra el selector de ajuste. Tenga cuidado de no correr la rosca.*
- If having trouble installing knobs place rack on its side.  
Si vous rencontrez des difficultés à installer les écrous à ailettes, placez le porte-vélo sur son côté.  
*Si tiene problemas para instalar las perillas, coloque la parrilla de lado.*
- Check 2 Wing Adjustment Knobs periodically during use and retighten if needed.  
Vérifiez régulièrement les deux écrous de réglage à 2 ailettes pendant l'utilisation et resserrez s'il le faut.  
*Compruebe las perillas de ajuste de 2 alas de forma periódica mientras usa el portabicicletas y, si es necesario, vuelva a apretarlas.*

**4****a**

- **With buttons squeezed in, firmly slide carrier arms into the hub.**  
Avec les boutons suffisamment enfoncés, faites coulisser fermement les bras de support dans le moyeu.  
*Con los botones apretados, firmemente meta los brazos del portabicicletas al centro de conexión.*

**b**

- **Rotate arm until button engages in the hub.**  
Tournez le bras de façon à engager le bouton dans le moyeu.  
*Rotee el brazo hasta que el botón se enganche al centro de conexión.*

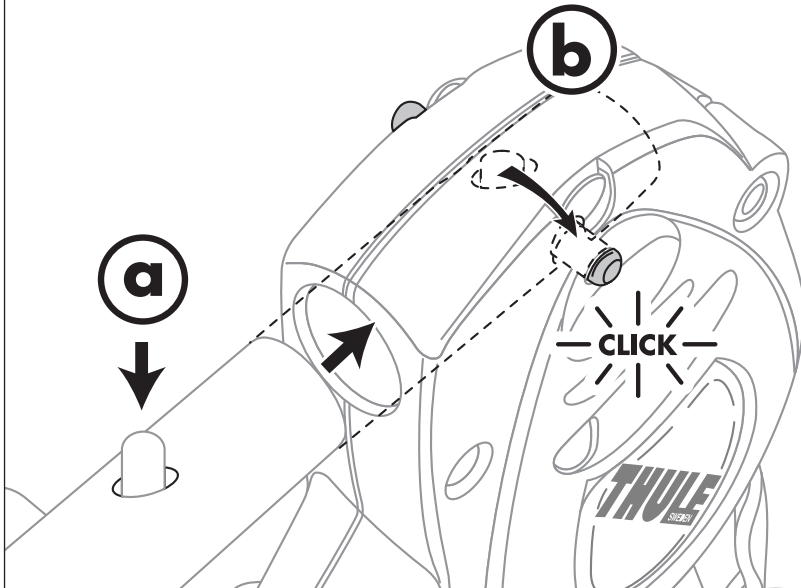
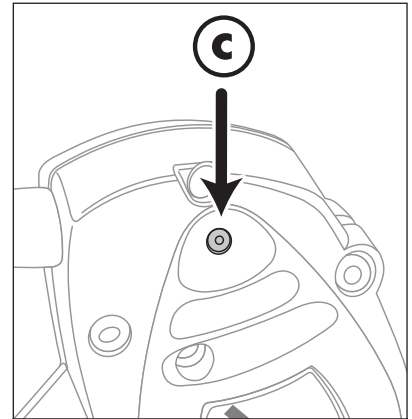
**c****c**

- **Ensure that buttons are visibly engaged in the hub when finished.**  
Une fois terminé, assurez-vous visuellement que les boutons sont bien engagés dans le moyeu.  
*Asegúrese que los botones estén visiblemente enganchados en el centro de conexión al terminar.*

**5**

- **Install cradle strap as illustrated.**  
Installez la courroie de berceau de la façon indiquée.  
*Coloque la correa del soporte de la manera indicada.*

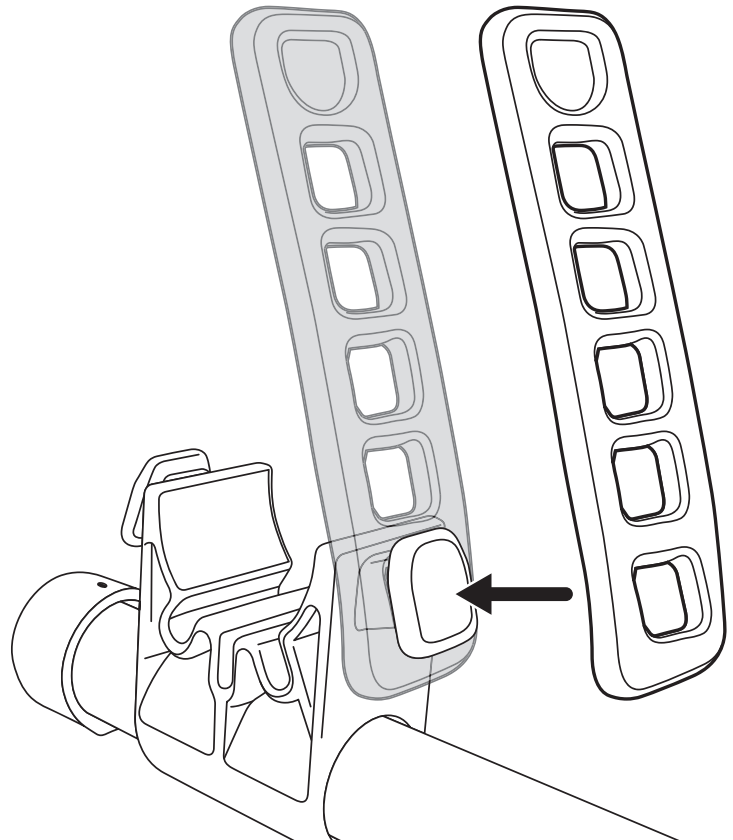

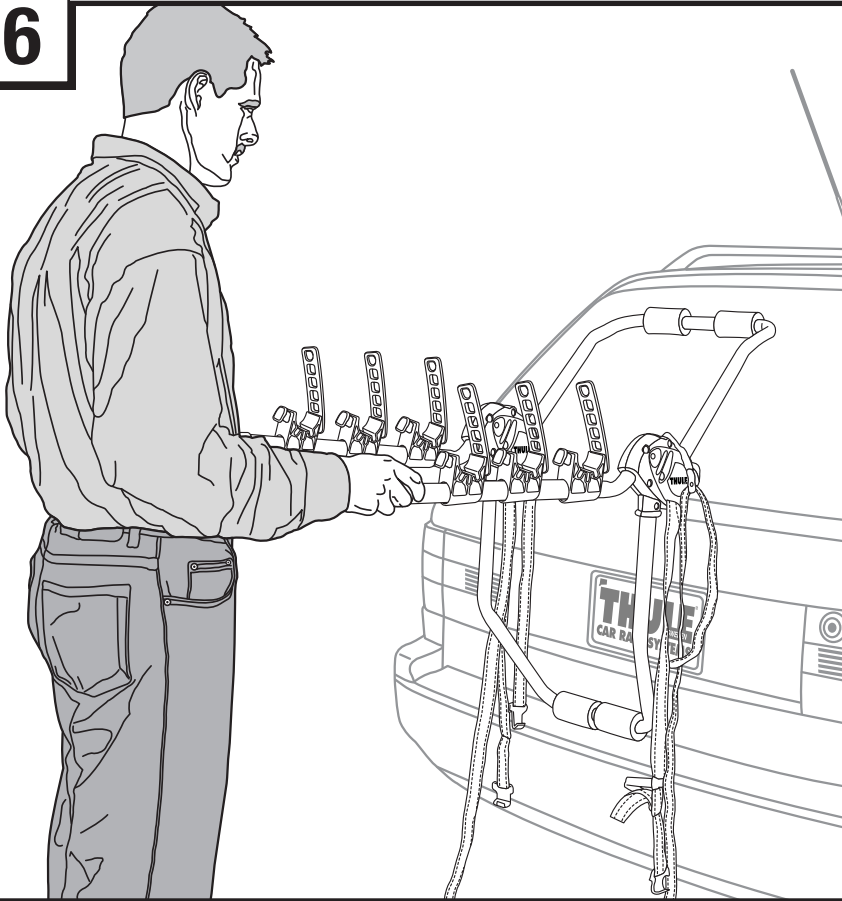
**6**

- **Mount carrier to the back of vehicle. Refer to Fit Tips for specific placement instructions.**

Installez le porte-vélo à l'arrière du véhicule. Référez-vous aux Conseils de réglage pour déterminer l'emplacement exact.

*Monte el portabicicletas en la parte trasera de su vehículo. Refiérase a los puntos de encaje para obtener instrucciones específicas de colocación.*

**NOTE:** Arms should be level or pointing slightly upward.

**REMARQUE:** Les bras de support doivent être à l'horizontale ou pointés légèrement vers le haut.

**NOTA:** Los brazos deben estar nivelados o apuntando ligeramente hacia arriba.

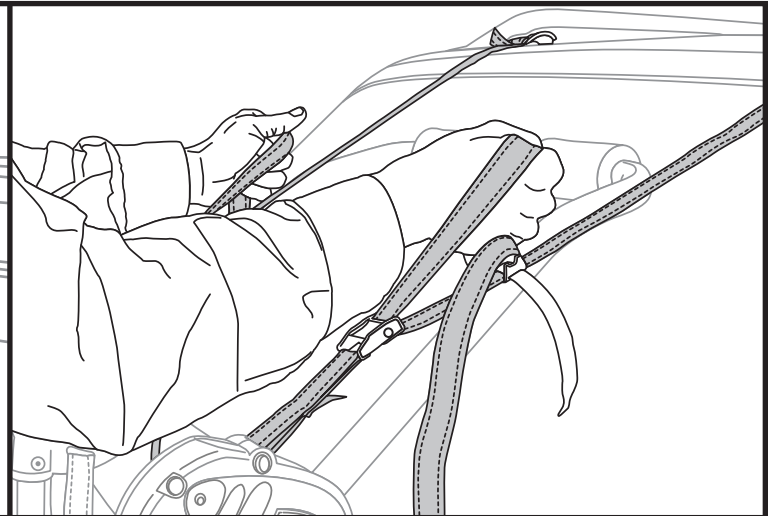
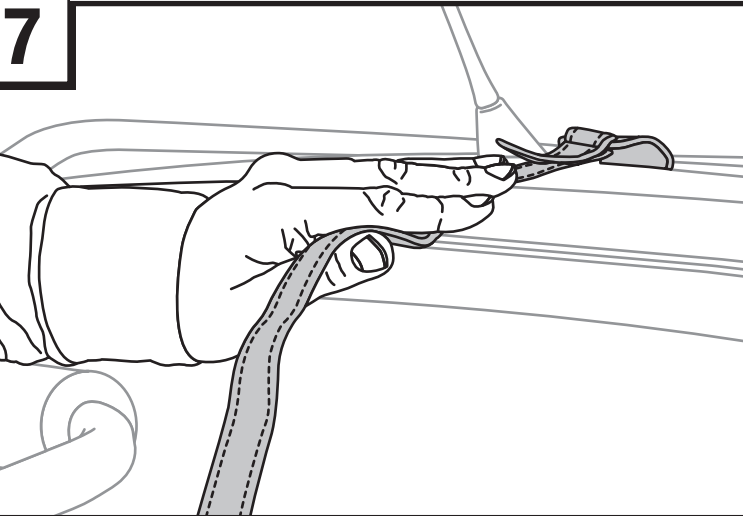
**7****a**

- **Attach top strap according to the Fit Tips for your car.**

Installez les sangles supérieures conformément aux Conseils de réglage s'appliquant à votre véhicule.

*Sujete la correa superior de acuerdo a los puntos de encaje para su carro.*

**NOTE:** If versa clip is required for proper mounting, go to step 15 before continuing.

**REMARQUE:** Si un crochet Versa-Clip est nécessaire pour une installation correcte, veuillez passer à l'étape 15 avant de continuer.

**NOTA:** Si un Versa Clip es requerido para el montaje apropiado, vea el paso 15 antes de continuar.

**b**

- **Tighten top straps, by pulling on the loose end, so the carrier stays in position.**

Serrez les sangles supérieures de façon à ce que le porte-vélo demeure en position.

*Para asegurar que el portabicicletas permanezca en su posición, apriete las correas, tirando el lado suelto de éstas.*

**NOTE:** Tighten straps only enough to hold rack in place without changing its position as instructed in the fit tips.

**REMARQUE:** Ne tendez les sangles que pour maintenir le porte-vélo en place, sans le déplacer, comme indiqué dans les conseils de réglage.

**NOTA:** Apriete las correas solamente lo suficiente para que la parrilla permanezca en su sitio sin cambiar su posición según se indica en los consejos de ajuste.

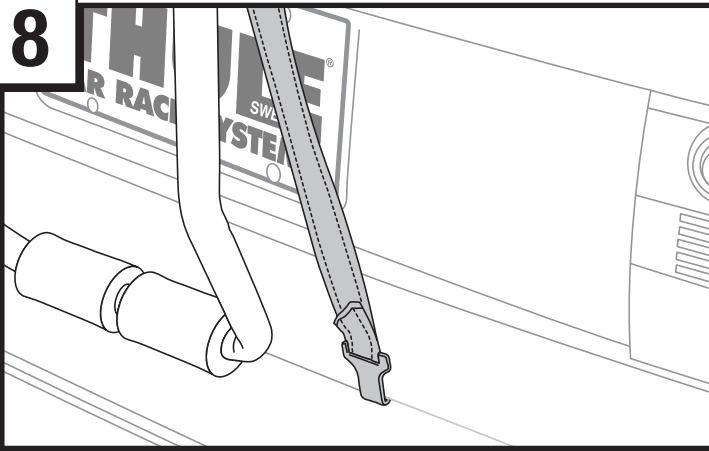
**8**

- **Attach bottom straps (narrow, grey hooks) according to the Fit Tips for your car. Always make sure that straps are out of the way of hot exhaust gases and not in contact with the muffler or exhaust pipe.**

Installez les sangles inférieures conformément aux Conseils de réglage s'appliquant à votre véhicule. Assurez-vous que les sangles n'entrent pas en contact avec le tuyau d'échappement ni avec le silencieux.

*Enganche las correas inferiores (gancho gris delgado) de acuerdo a los puntos de encaje de su carro. Asegúrese siempre de que las correas estén lejos de las emisiones de gases calientes y de que no estén en contacto con el tubo de escape.*

- **Be sure lower arm is in correct position.**

Assurez-vous que le bras inférieur est en position correcte.

*Asegúrese que el brazo inferior está en la posición correcta.*

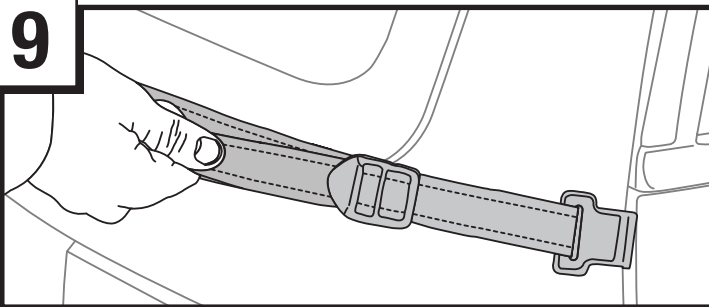
**9**

- **Attach side straps to side seams of trunk, hatch, or door.**

Fixez les sangles latérales sur les côtés du coffre, du hayon ou de la porte.

*Enganche las correas laterales a las grietas del portamaletas o puerta trasera.*

**10**

- **Retighten all straps to ensure a snug fit to vehicle.**

Resserrez fermement toutes les sangles pour assurer une fixation correcte sur le véhicule.

*Apriete una vez más para asegurar un buen calce en su vehículo.*

- **Roll up loose strap ends and secure.**

Enroulez les bouts libres des sangles.

*Enrolle los extremos sueltos de las correas.*

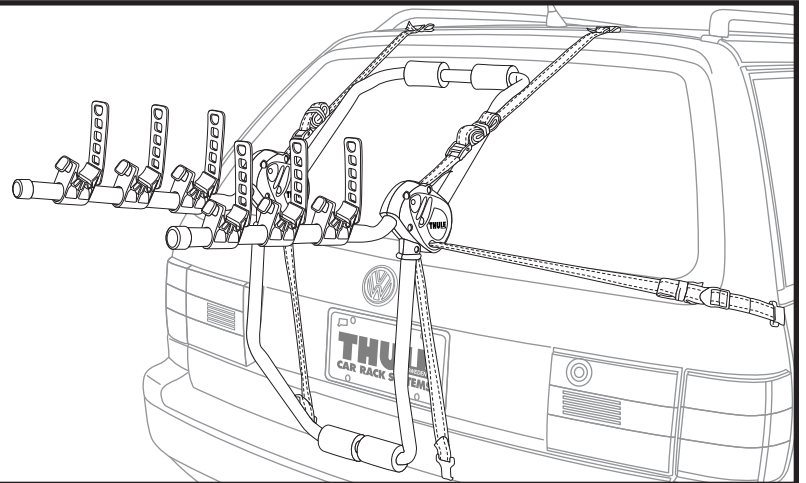
**11**

## LOADING/SECURING BIKES / CHARGEMENT/FIXATION DES VÉLOS / CARGA Y SUJECIÓN DE LAS BICICLETAS

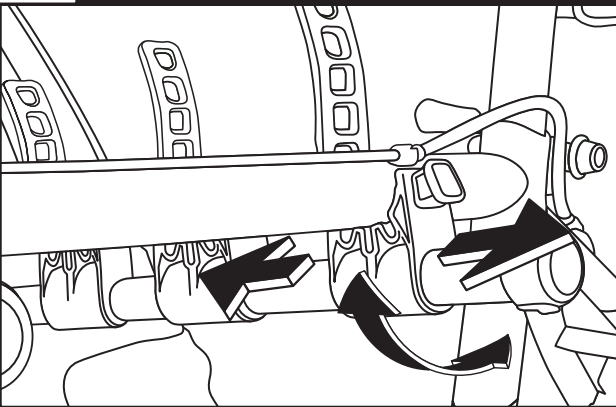

- **Load heaviest bike first onto inner most cradle.**

Chargez le vélo le plus lourd en premier, sur les berceaux les plus à l'intérieur.

*Cargar la bicicleta más pesada primero en las cunas más interiores.*

- **Cradles can be either rotated or shifted on bars to accommodate different bike geometries.**

Les berceaux peuvent être soit tournés soit changés sur les barres pour les adapter aux différentes géométries de vélos.

*Las cunas se pueden girar o mover para acomodar bicicletas de geometrías diferentes.*

- **Alternate direction of bikes when loading.**

Alternez le sens des vélos lors du chargement.

*Alternar la dirección de las bicicletas cuando se carguen.*

# 12

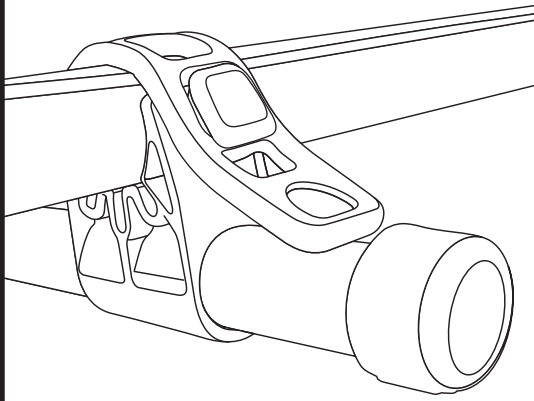

- **Ensure straps are tightened securely around bike frame.**  
Assurez-vous que les sangles sont bien serrées autour du cadre du vélo.  
*Asegurar que las correas estén bien sujetas alrededor del marco de la bicicleta.*
- **Ensure adequate ground clearance fo bicycle wheels.**  
Assurez-vous d'une garde au sol adéquate pour les roues des vélos.  
*Asegúrese de que haya espacio suficiente entre la carretera y las ruedas de las bicicletas.*
- **Position bicycles on rack in order to prevent bike to car contact.**  
Positionnez les vélos sur le porte-vélos de façon à éviter le contact entre vélos et véhicule.  
*Coloque las bicicletas en el portabicicletas de forma de evitar que toquen el auto.*

**NOTE:** Cradles can be either rotated or shifted on bars to accommodate different bike geometries.

**REMARQUE:** Les berceaux peuvent être soit tournés soit changés sur les barres pour les adapter aux différentes géométries de vélos.

**NOTA:** Las cunas se pueden girar o mover para acomodar bicicletas de geometrías diferentes.

**NOTE:** Alternate direction of bikes when loading.

**REMARQUE:** Alternez le sens des vélos lors du chargement.

**NOTA:** Alternar la dirección de las bicicletas cuando se carguen.

# 13

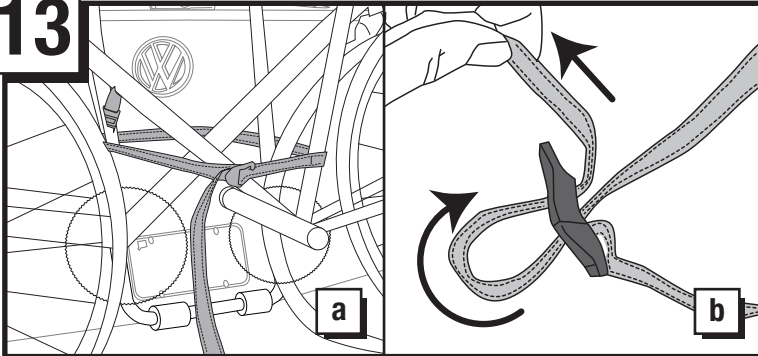

- **Using blue load strap provided secure all bikes to the frame of the rack as illustrated.**

À de la sangle de charge bleue fournie, fixez tous les vélos sur le porte-vélos, comme illustré.

*Usando la correa de carga azul que se suministra, sujete todas las bicicletas en el portabicicletas según se muestra en el dibujo.*

# 14

## BIKE ARM STORAGE / RANGEMENT DU BRAS DE VÉLO / BRAZO DE ALMACENAMIENTO PARA BICICLETA

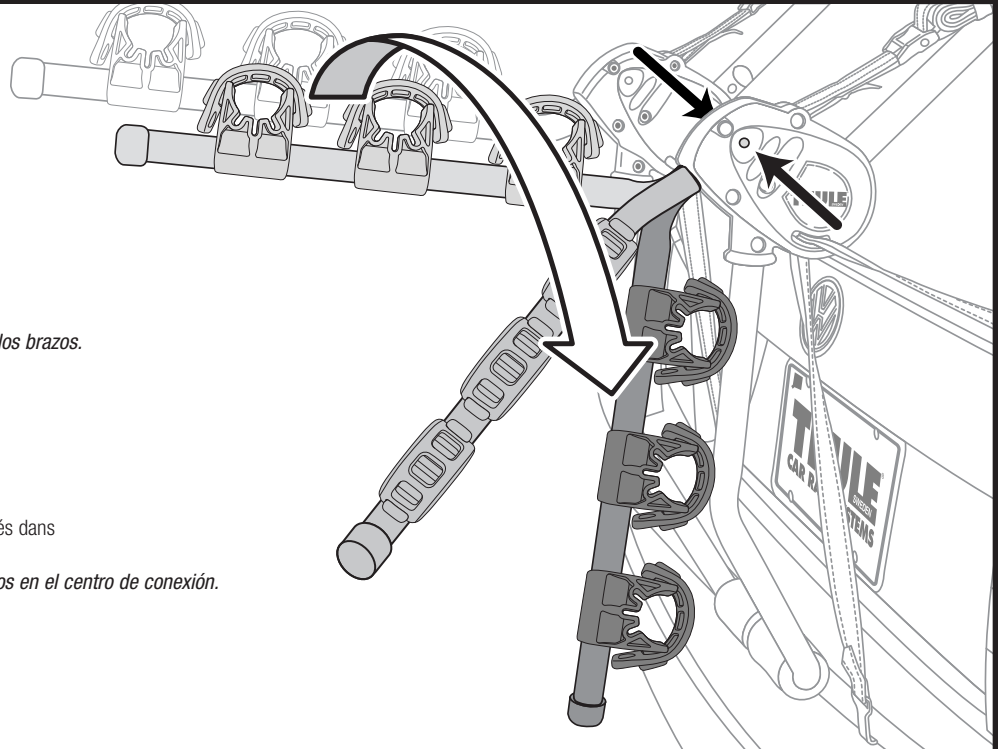

- **Squeeze buttons on hub to release arms.**  
Pressez les boutons dans le moyeu afin de libérer les bras.  
*Apriete los botones en el centro de conexión para librar los brazos.*
- **Rotate arms down.**  
Tournez les bras du support vers le bas.  
*Gire los brazos hacia abajo.*
- **Ensure buttons are engaged in hub when finished.**  
Assurez-vous que les boutons sont correctement enclenchés dans le moyeu une fois l'opération terminée.  
*Al final, asegúrese de que los botones estén enganchados en el centro de conexión.*

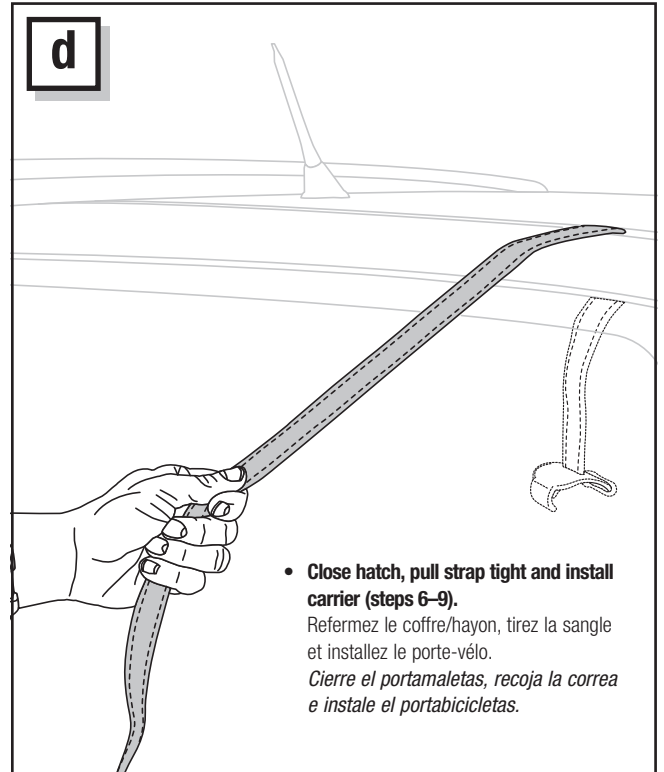
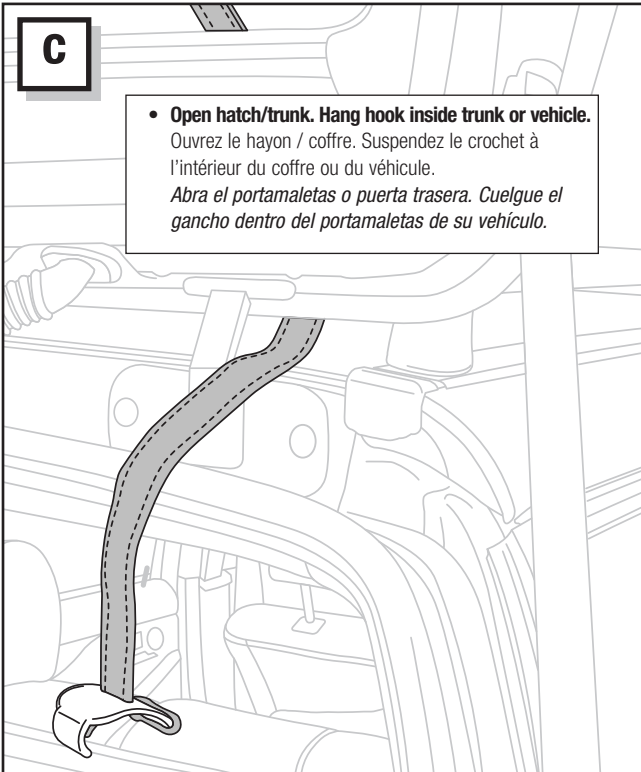
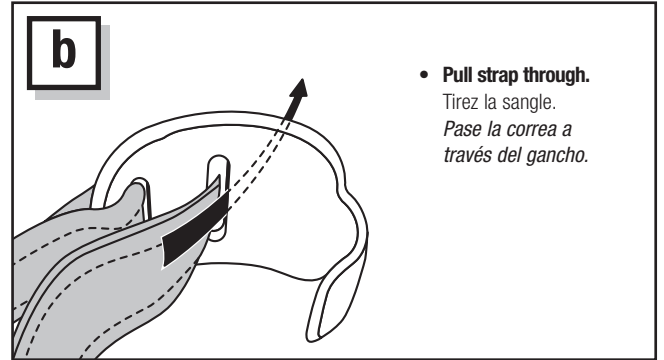
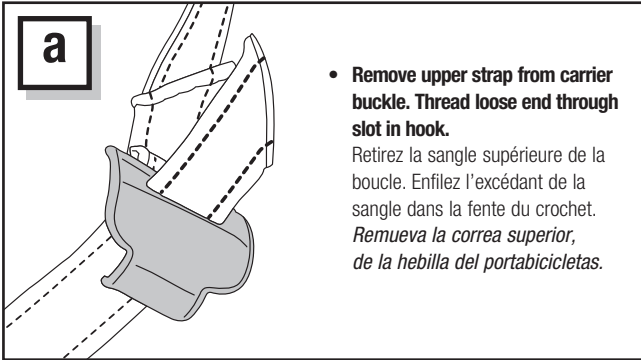

## THULE RACK GUIDELINES

When using Thule Load Carriers and accessories, the user must understand the precautions. The points listed below will assist you in using the rack system and will encourage safety.

- For quality fits and safety, use only the recommended rack or accessory as stated in Thule's current Fit Guide. Do not assume a rack will fit, always check the current Fit Guide when obtaining a new vehicle.
- Unless stated otherwise in these instructions, do not carry more than 75 kg (165 lbs.) on Thule Load Carriers. Thule Load Carriers do not increase gutter or roof strength. Thule can not warranty loads that exceed this limit. Total load = cargo weight plus weight of accessories used to carry cargo.
- Always make sure all doors are open when mounting a roof rack system. Make sure all knobs, bolts, screws, straps, and locks are firmly attached, tightened and locked before every trip. Knobs, bolts, screws straps and locks must be periodically inspected for signs of wear, corrosion, and fatigue. Check your load at stops during the trip to ensure continued fastening security.
- Check local and state laws governing projection of objects beyond the perimeter of a vehicle. Be aware of the width and height of your cargo since low clearance branches, bridges, and parking garages can affect the load. All cargo will affect the vehicle's driving behavior. Never drive with any lock, knob or rack in an open or unlocked position. All long loads such as, but not limited to, sailboards, surfboards, kayaks, canoes, and lumber must be tied down front and rear to the bumpers or tow hooks of the vehicle.
- Remove your Thule rack and accessories when they are not in use and before entering automatic car washes.
- All locks must be turned and moved periodically to ensure smooth operation. Use graphite or dry lubricant to help this. Thule locks are designed to deter vandalism and theft but should not be considered theft proof. Remove valuable gear if your vehicle is unattended for an extended period. Place at least one key in the glove compartment.
- For safety to your vehicle and rack system, obey all posted speed limits and traffic cautions. Adapt your speed to the conditions of the road and the load being carried.
- Do not use Thule load carriers and accessories for purposes other than those for which they were designed. Do not exceed their carrying capacity. Failure to follow these guidelines or the product's instructions will void the warranty.
- Consult with your Thule dealer if you have any questions regarding the operations and limits of Thule products. Review all instructions and warranty information carefully.
- Not for use on trailers or towed vehicles.
- Not for offroad use.
- Keep bicycle tires away from hot exhaust.

## DIRECTIVES POUR SUPPORT THULE

Lorsque vous utilisez les supports et accessoires Thule pour voiture, vous devez observer les précautions suivantes. Les conseils ci-dessous visent à faciliter l'emploi de votre galerie et à l'utiliser en toute sécurité.

- Pour respecter les règles de sécurité et obtenir un ajustement de qualité, utilisez uniquement le produit ou l'accessoire recommandé dans le guide actuel de correspondance de Thule. Ne présumez pas qu'un produit sera adapté; consultez toujours ce guide de correspondance lorsque vous achetez un nouveau véhicule.
- Sauf indication contraire, ne dépassez pas la capacité maximale de 75 kg (165 lb) permise pour les porte-charge de Thule. Ne transportez pas plus de 75 kg (165 lb) sur les galeries Thule. Ces dernières ne renforcent pas votre toit ni les points de fixation. Les charges dépassant cette limite ne peuvent pas être garanties. Charge totale = poids du chargement + poids des accessoires utilisés pour le transporter.
- Assurez-vous toujours que les portes de la voiture sont ouvertes lors de l'installation d'une galerie. Avant de prendre la route, assurez-vous que les molettes, les boulons et les vis sont bien serrés, les sangles bien attachées et les dispositifs de verrouillage fermés à clés. Examinez régulièrement ces éléments afin de déceler tout signe d'usure, de corrosion ou de fatigue. Vérifiez votre chargement à tous les arrêts pendant votre voyage pour vous assurer qu'il est bien attaché.
- Vérifiez les lois locales ou provinciales sur le dépassement d'objets sur les côtés d'un véhicule. Soyez conscient de la largeur et de la hauteur de votre chargement pour passer sous les branches basses, les ponts et les plafonds de stationnement couverts. Tout chargement modifie la tenue de route du véhicule. Ne conduisez jamais avec une serrure, une barre ou un écrou ouverts ou non bloqués. Tous les chargements longs, de type surfs, planches à voile, kayaks, canoës, bois, etc. doivent être attachés à l'avant et à l'arrière aux pare-chocs ou aux crochets de remorquage du véhicule.
- Retirez votre galerie et vos accessoires Thule lorsque vous ne les utilisez pas et avant de passer au lave-auto.
- Faites fonctionner régulièrement toutes les serrures afin qu'elles ne se grippent pas. Employez du graphite ou un lubrifiant sec pour conserver leur souplesse. Les antivols Thule sont conçus pour dissuader les voleurs et éviter les actes de vandalisme. Retirez tout matériel de valeur de votre véhicule s'il doit rester sans surveillance pendant une période prolongée. Gardez au moins une clé dans la boîte à gants. Pour protéger votre véhicule et votre galerie, respectez les vitesses limites et le code de la route. Adaptez votre vitesse aux conditions de la route et à la charge transportée.
- N'utilisez pas de galerie et d'accessoires Thule à d'autres fins que celles pour lesquelles ils ont été conçus. Ne dépassez pas leur capacité de charge maximale. Le non-respect de ces consignes et des instructions spécifiques au produit annulera la garantie.
- Consultez votre revendeur pour toute question sur le fonctionnement et les limites des produits Thule. Lisez attentivement toutes les instructions et les informations de la garantie.
- Ne pas utiliser sur une remorque ou un véhicule remorqué.
- Ne pas utiliser pour la conduite hors route.
- Garder les pneus de vélo éloignés du tuyau d'échappement chaud.

## PAUTAS PARA BASTIDORES THULE

Cuando use portacargas y accesorios Thule, debe asegurarse de entender todas las precauciones. Los puntos indicados a continuación le ayudarán a usar el sistema de bastidor y fomentarán su seguridad.

- Por seguridad y para obtener un ajuste correcto, use solamente el bastidor o accesorio Thule recomendado según en la Guía de ajuste Thule más actual. No suponga el ajuste del bastidor, siempre verifique la Guía de ajuste más actual cuando compre un nuevo vehículo.
- Salvo instrucción contrario, no se debe superar la capacidad máxima de 75 kg (165 lb) designada para los portacargas de Thule. No transporte más de 75 kg (165 lb.) en los portacargas Thule. Los portacargas Thule no incrementan la resistencia de las canaletas ni del techo. Thule no garantiza cargas que excedan este límite. Carga total = el peso de la carga + el peso de los accesorios usados para el transporte.
- Siempre asegúrese que las puertas del automóvil estén abiertas cuando monte un sistema de bastidor para techo. Cerciórese de que las perillas, los pernos, los tornillos, las correas y las cerraduras estén firmemente sujetos, apretados y asegurados con llave antes de cada viaje. Debe revisar periódicamente que las perillas, los pernos, los tornillos, las correas y los seguros no tengan señales de desgaste, corrosión o fatiga. Revise su carga en las paradas durante su viaje para garantizar la seguridad continua de la sujeción.
- Verifique las leyes estatales y locales que rigen la proyección de objetos más allá del ancho del vehículo. Esté al tanto de la anchura y altura de su carga, ya que las ramas, los puentes, los estacionamientos de baja altura pueden dañar su carga. Toda carga afectará el comportamiento de manejo del vehículo. Nunca conduzca con alguno de los seguros, las perillas o los bastidores abiertos o sin seguro. Todas las cargas largas, como tablas a vela, tablas de surf, kayacs, canoas y madera, deben atarse al frente y atrás los parachoques o ganchos de remolque del vehículo.
- Quite su bastidor y accesorios Thule cuando no se usen y antes de entrar a establecimientos para lavado automático de vehículos.
- Todas los seguros deben girarse y moverse periódicamente para garantizar que no se atasquen. Use grafito u otro lubricante en seco similar para este fin. Los seguros Thule están diseñados para disuadir el vandalismo y los robos. Saque todo equipo valioso si su vehículo no tendrá vigilancia por largo tiempo. Ponga por lo menos una llave en la guantera.
- Como seguridad para su vehículo y sistema de bastidor, obedezca todos los límites de velocidad y avisos de tráfico. Adapte su velocidad a las condiciones del camino y de la carga transportada.
- No use portacargas y accesorios Thule con otra función para la que fue destinada. No exceda su capacidad de carga. Se anulará la garantía si no sigue estos lineamientos o las instrucciones del producto.
- Consulte a su distribuidor Thule si tiene alguna pregunta sobre el funcionamiento y los límites de los productos Thule. Repase cuidadosamente todas las instrucciones y la de garantía.
- No use en tráilers o vehículos de remolque.
- No conduzca fuera del camino.
- Mantenga las ruedas de las bicicletas lejos del tubo de escape caliente.

**THULE**<sup>®</sup>  
SWEDEN

THULE INC., 42 SILVERMINE RD.  
SEYMOUR, CT 06483  
www.thule.com  
800-238-2388



# THULE CAR RACK SYSTEMS LIMITED LIFETIME WARRANTY [EFFECTIVE JANUARY 1, 2006]

## Register online at [www.thuleracks.com/register](http://www.thuleracks.com/register)

**THULE will warranty all THULE brand car rack systems and its accessories manufactured by THULE during the time that an original retail purchaser owns the product. This warranty terminates if a purchaser transfers the product to any other person.**

**Subject to the limitations and exclusions described in this warranty, THULE will remedy defects in materials or workmanship by repairing or replacing, at its option, a defective product without charge for parts or labor. In addition, THULE may elect, at its option, not to repair or replace a defective product but rather issue to a purchaser a refund equal to the purchase price paid for the product or a credit to be used toward the purchase of a new THULE load carrier system.**

**No warranty is given for defects caused by normal wear and tear, cosmetic rust, scratches, accidents, unlawful vehicle operation, or modification of, or any types of repair of, a load carrier system other than those authorized by THULE.**

**No warranty is given for defects resulting from conditions beyond THULE's control including, but not limited to, misuse, overloading, or failure to assemble, mount or use the product in accordance with THULE's written instructions or guidelines included with the product or made available to the purchaser.**

**No warranty is given for Thule products purchased outside of the United States, Canada and Mexico.**

**In the event that a product is defective, the purchaser should contact the THULE dealer from whom it purchased the product or an Authorized Thule Service Center. If the dealer or Authorized Thule Service Center is not able to correct the defect, the purchaser should contact THULE in writing or by phone at:**

**THULE 42 Silvermine Road Seymour, Connecticut 06483 Attn: Customer Service 203 881-9600**

**In the event that a product needs to be returned to THULE, a THULE technician at the address or telephone number listed above will provide the purchaser with the appropriate mailing address and any additional instructions. Please note that the purchaser will be responsible for the cost of mailing the product to THULE and that proof of purchase in the form of an original purchase invoice or receipt and a detailed description of the defect must be included in the mailing.**

**DISCLAIMER OF LIABILITY  
REPAIR OR REPLACEMENT OF A DEFECTIVE PRODUCT OR THE ISSUANCE OF A REFUND OR CREDIT (AS DETERMINED BY THULE) IS A PURCHASER'S EXCLUSIVE REMEDY UNDER THIS WARRANTY. DAMAGE TO A PURCHASER'S VEHICLE, CARGO AND/OR TO ANY OTHER PERSON OR PROPERTY IS EXCLUDED.**

**THIS WARRANTY IS EXPRESSLY MADE IN LIEU OF ANY AND ALL OTHER WARRANTIES, EXPRESS OR IMPLIED, INCLUDING THE WARRANTIES OF MERCHANTABILITY AND FITNESS FOR A PARTICULAR PURPOSE.**

**THULE'S SOLE LIABILITY TO ANY PURCHASER IS LIMITED TO THE REMEDY SET FORTH ABOVE. IN NO EVENT WILL THULE BE LIABLE FOR ANY LOST PROFITS, LOST SALES, OR FOR ANY CONSEQUENTIAL, DIRECT, INDIRECT, INCIDENTAL, SPECIAL, EXEMPLARY, OR PUNITIVE DAMAGES OR FOR ANY OTHER DAMAGES OF ANY KIND OR NATURE.**

**SOME STATES DO NOT ALLOW THE EXCLUSION OR LIMITATION OF INCIDENTAL OR CONSEQUENTIAL DAMAGES, SO THE ABOVE LIMITATIONS MAY NOT BE APPLICABLE.**

**THIS WARRANTY GIVES YOU SPECIFIC LEGAL RIGHTS, AND YOU MAY ALSO HAVE OTHER RIGHTS WHICH VARY FROM STATE TO STATE.**

THULE garantit tous les systèmes de support de la marque THULE pour voitures et ses accessoires fabriqués par THULE tant que le premier acheteur au détail détient le produit. Cette garantie prend fin si un acheteur transfère le produit à une personne.

Selon les limites et les exclusions décrites dans cette garantie, THULE remédiera aux défauts de matériaux ou de main d'œuvre en réparant ou en remplaçant, à sa discrétion, un produit défectueux sans frais de pièces ou de main d'œuvre. De plus, THULE peut décider, à sa discrétion, de ne pas réparer ou remplacer un produit défectueux mais d'émettre un remboursement de l'acheteur égal au prix payé pour le produit, ou un crédit à utiliser pour l'achat d'un système de support de charge THULE neuf.

Aucune garantie n'est émise pour les défauts causés par une usure normale, pour la rouille esthétique, pour les rayures, pour l'utilisation inadéquate du véhicule, pour toute modification de celui-ci, pour tout type de réparation, pour un système de support de charge autre que ceux autorisés par THULE.

Aucune garantie n'est émise pour les défauts résultant de conditions hors du contrôle de THULE, notamment une mauvaise utilisation, une surcharge ou un assemblage ou montage non conformes aux instructions écrites ou directives de THULE incluses avec le produit ou mises à disposition de l'acheteur.

Aucune garantie n'est émise pour les produits Thule achetés hors des États-Unis, du Canada ou du Mexique.

Si un produit est défectueux, l'acheteur doit contacter le revendeur THULE auquel il a acheté le produit ou un centre de service Thule autorisé. Si le revendeur ou le centre de services Thule autorisé n'est pas en mesure de corriger le défaut, l'acheteur doit contacter THULE par écrit ou au téléphone à :

THULE 42 Silvermine Road Seymour, Connecticut 06483  
Attn: Customer Service 203 881-9600

Dans l'éventualité où un produit doit être renvoyé à THULE, un technicien THULE à l'adresse ou au numéro de téléphone indiqué ci-dessus fournira à l'acheteur l'adresse d'envoi appropriée et des instructions supplémentaires. Veuillez noter que l'acheteur sera responsable des frais d'envoi du produit à THULE et qu'une preuve d'achat sous la forme de l'original d'une facture ou d'un reçu d'achat et une description détaillée du défaut doivent être inclus dans l'envoi.

### DÉNI DE RESPONSABILITÉ

LA REPARATION OU LE REMPLACEMENT D'UN PRODUIT DEFECTUEUX OU L'EMISSION D'UN REMBOURSEMENT OU D'UN CREDIT (SELON LE CHOIX DE THULE) CONSTITUE LE RECOURS EXCLUSIF DE L'ACHETEUR SOUS CETTE GARANTIE. LES DEGATS AU VEHICULE DE L'ACHETEUR, AU CHARGEMENT OU/ET A TOUTE AUTRE PERSONNE OU BIEN SONT EXCLUS.

CETTE GARANTIE REMPLACE EXPRESSÉMENT TOUTES LES AUTRES GARANTIES EXPRESSES OU IMPLICITES Y COMPRIS TOUTE GARANTIE DE QUALITÉ MARCHANDE ET DE CONFORMITÉ À UN USAGE PARTICULIER.

LA SEULE RESPONSABILITÉ DE THULE ENVERS TOUT ACHETEUR EST LIMITÉE AU RECOURS DÉFINI CI-DESSUS. EN AUCUN CAS THULE NE PEUT ÊTRE TENU RESPONSABLE DES PERTES DE REVENUS, DE PERTES DE VENTES, DES DOMMAGES DIRECTS OU INDIRECTS, ACCESSOIRES, PARTICULIERS, SPÉCIAUX, INTÉRÊTS MAJORÉS OU PUNITIFS OU DE TOUT AUTRE DOMMAGE DE TOUT TYPE OU NATURE.

CERTAINS ÉTATS OU PROVINCES N'AUTORISENT PAS L'EXCLUSION OU LA LIMITATION DES DOMMAGES ACCESSOIRES OU INDIRECTS, LES LIMITATIONS DÉCRITES CI-DESSUS PEUVENT DONC NE PAS ÊTRE APPLICABLES.

CETTE GARANTIE VOUS DONNE DES DROITS SPÉCIFIQUES QUI PEUVENT VARIER D'UN ÉTAT OU PROVINCE À L'AUTRE.

THULE garantizará todos los sistemas portacargos de la marca THULE y sus accesorios fabricados por THULE mientras el comprador original esté en posesión del producto. Esta garantía finaliza si un comprador transfirió el producto a cualquier otra persona.

Según las limitaciones y exclusiones que se describen en esta garantía, THULE remediará cualquier defecto en los materiales o la mano de obra reparando o reemplazando, a discreción propia, cualquier producto defectuoso sin cobrarle al propietario por las piezas o la mano de obra. Además, THULE puede optar, a discreción propia, a no reparar o reemplazar un producto defectuoso y en su lugar devolver al comprador el dinero del precio que pagó por el producto o dotarle un crédito que puede usarse para comprar un nuevo sistema portacargos THULE.

No se otorga garantía alguna por los defectos causados por el uso y desgaste normales, la corrosión cosmética, las ralladuras, los accidentes o la conducción ilegal del vehículo, o cualquier modificación o reparación del sistema portacargos sin incluir aquellas modificaciones o reparaciones autorizadas por THULE.

No se otorga garantía alguna por los defectos que resulten de condiciones más allá del control de THULE que incluyen, pero no se limitan a, el uso indebido, la sobrecarga, la instalación, montaje o usos incorrectos del producto según las instrucciones o las directrices escritas de THULE adjuntas con el producto o que estén a disposición del comprador.

No se otorga garantía alguna por los productos Thule que se compran fuera de los Estados Unidos, Canadá o México.

En el caso de que un producto sea defectuoso, el comprador deberá contactar al concesionario THULE donde compró el producto o a un Centro de Servicio Thule Autorizado. Si el concesionario o el Centro de Servicio Thule Autorizado no puede corregir el defecto, el comprador deberá contactar a THULE por escrito o llamando a:

THULE 42 Silvermine Road Seymour, Connecticut 06483 Attn: Customer Service 203 881-9600

En el caso de que el producto deba devolverse a THULE, un técnico de THULE en la dirección o número de teléfono indicados anteriormente le proporcionará una dirección postal donde enviarlo así como instrucciones adicionales. Por favor observe que el comprador será responsable de abonar el costo de enviar el producto THULE y que debe adjuntar una prueba de compra como una factura o un recibo original así como una descripción detallada del defecto.

**DESCARGO DE RESPONSABILIDAD  
BAJO ESTA GARANTÍA, LA ÚNICA SOLUCIÓN PARA EL COMPRADOR ES EL REEMPLAZO DEL PRODUCTO DEFECTUOSO, LA DEVOLUCIÓN DEL DINERO O DOTACIÓN DE CRÉDITO (SEGÚN LO DETERMINE THULE). SE EXCLUYEN LOS DAÑOS AL VEHÍCULO DEL COMPRADOR, A LA CARGA O A CUALQUIER OTRA PERSONA O PROPIEDAD.**

**ESTA GARANTÍA SE HACE DE FORMA EXPRESA EN VEZ DE CUALQUIER OTRA GARANTÍA, IMPLÍCITA O EXPLÍCITA, INCLUSO LAS GARANTÍAS DE COMERCIABILIDAD Y ADECUACIÓN PARA PROPÓSITOS CONCRETOS.**

**LA ÚNICA RESPONSABILIDAD DE THULE HACIA EL COMPRADOR SE LIMITA A LA SOLUCIÓN ESTABLECIDA ANTERIORMENTE. EN NINGÚN CASO SERÁ THULE RESPONSABLE DE NINGÚN BENEFICIO PERDIDO, VENTAS PERDIDAS O DE CUALQUIER DAÑO CONSECUENTE, DIRECTO, INDIRECTO, INCIDENTAL, ESPECIAL, EJEMPLAR O PUNITIVO DE CUALQUIER TIPO O ÍNDOLE.**

**ALGUNOS ESTADOS NO PERMITEN LA EXCLUSIÓN O LA LIMITACIÓN DE DAÑOS INCIDENTALES O CONSECUENTES, POR CONSIGUIENTE EN ESOS ESTADOS LAS LIMITACIONES ANTERIORES NO SON APLICABLES.**

**ESTA GARANTÍA LE OTORGA DERECHOS LEGALES ESPECÍFICOS Y USTED TAMBIÉN PUEDE TENER OTROS DERECHOS QUE VARIAN DE UN ESTADO A OTRO.**

Register online at [www.thuleracks.com/register](http://www.thuleracks.com/register) THULE 42 Silvermine Road Seymour, Connecticut 06483 203 881-9600



Make/Model	Years	961xt/ 910	962xt/ 911	Setting	Fit tips
<b>Acura</b>					
CL 2dr	'01-03	✓	✓	6	101,102,128
	'96-00	✓	✓	6	101,104,125,128
EL 4dr	'01-03	✓	✓	6	101,102,128
	'96-00	✓		6	101,102,132
Integra 3dr	'94-01	✓	✓	6	101,105,125,128,143
	'90-93				135,136
Integra 4dr	'94-01	✓		5	101,102,110,132,140
	'90-93				135,136
Legend 2dr	'91-95	✓	✓	5	101,102,140
	'87-90	✓	✓	5	101,102,140
Legend 4dr	'91-95	✓	✓	5	101,102
	'86-90	✓	✓	5	101,103,125,140
MDX	'07				135
MDX	'01-06	✓	✓	9	101,102,121,127,128
RDX	'07				135
RL 4dr	'05-07	✓	✓	7	101,102,128
	'96-04	✓		6	101,110,132
RSX	'02-06				134,137
SLX	'96-99				
TL	'04-07	✓	✓	7	101,128,147
	'99-03	✓	✓	7	101,102,128
	'95-98	✓		5	101,102,132
TSX	'04-07	✓	✓	7	101,128,147
Vigor	'91-95	✓		5	101,102,132
<b>Audi</b>					
100 & 200 Series	'92-94	✓	✓	5	101,102,138
	'91-91	✓	✓	7	101,131
	'88-90	✓	✓	7	101,131
80 & 90 Series	'93	✓	✓	5	101,102,138
	'91-92	✓	✓	7	101,104
A3	'06-07	✓	✓	8	101,102,128
A4 4dr	'02-07	✓		6	101,102,116,128,132
	'95-01	✓	✓	6	101,102,138
A4 wagon	'02-07				137
	'97-01				137
A6 4dr	'05-07	✓	✓	6	101,102,138
	'98-04				135
	'95-97				133
A6 wagon	'99-04				137
	'97-98				137
	'95-96	✓	✓	8	101,102
A8	'04-07	✓	✓	7	101,102,128
	'96-03				135
Allroad	'01-05	✓	✓	9	101,102,121,128
Q7	'07				134
Quattro 2dr	'90-92				135
S4	'92-94	✓	✓	5	101,102,138
S4 4dr	'00-07	✓	✓	6	101,102,138
S4 wagon	'01-06				133,137
S6 4dr	'95-97				133
S6 wagon	'02-03				137
S8 4dr	'01-03				135
TT	'00-06				133
<b>BMW</b>					
3 Series 2dr	'07				check for update
	'00-06	✓	✓	7	101,102,128
	'92-99	✓	✓	6	101,102,138
	'89-91	✓	✓	5	101,109
3 Series 4dr	'06-07	✓		7	101,102,128,132
	'99-05	✓	✓	6	101,102,138

Make/Model	Years	961xt/ 910	962xt/ 911	Setting	Fit tips
	'92-98	✓	✓	6	101,102,138
	'89-91	✓	✓	5	101,109
3 Series compact ti	'95-99				134
3 Series wagon	'00-05	✓		9	101,102,121,128,132,143
5 Series 4dr	'04-07				133
5 Series 4dr	'97-03	✓	✓	5	101,102,138
	'89-95	✓	✓	5	101,102,138
5 Series wagon	'99-03	✓		8	101,102,121,128,132,143
	'92-96				134
6 series	'04-07	✓	✓	6	101,102,128
7 Series 4dr	'06-07	✓	✓	7	101,102,128
	'02-05				133
	'95-01				133
	'88-94				133
X3	'04-07				134
X5	'07				134
	'00-06				135,137
Z3	'96-02				133
Z4	'03-07				133
Z8	'00-03				135
<b>Buick</b>					
Century 4dr	'97-05	✓		6	101,105,125,132,138
	'91-96				132
Century wagon	'90-96	✓		8	101,105,125,132,138
LaCrosse	'05-07				135
LeSabre 4dr	'00-05	✓	✓	5	101,138,142
	'92-99	✓	✓	5	101,102,128
Lucerne	'06-07	✓	✓	8	101,102,105
Park Avenue 4dr	'97-05	✓	✓	6	101,138,142
	'91-96	✓	✓	6	101,105,138
Ranier	'04-07				135,137
Reatta	'88-91				134
Regal 2dr	'91-96	✓	✓	6	101,105,138
Regal 4dr	'97-04				135
	'91-96	✓	✓	6	101,105,138
Rendezvous	'02-07	✓		10	101,112,121,125,132,138,143
Riviera	'95-99				135
Roadmaster	'91-96				134
Skylark 2dr	'88-91	✓		6	101,105,132
Skylark 4dr	'92-97	✓	✓	5	101,105,117,118
	'86-91	✓		6	101,105,132
Terraza	'05-07	✓	✓	11	101,102,121,128
<b>Cadillac</b>					
Catera	'97-01	✓	✓	6	101,105,125,128
CTS 4dr	'03-07				135
DeVille 4dr	'00-05	✓	✓	7	101,102,128
	'94-99	✓	✓	6	101,102,138
DTS	'06-07	✓	✓	7	101,102,128
Eldorado 2dr	'94-02				133
	'92-93	✓	✓	6	101,102,138
	'87-91				135
Escalade	'07				134
	'02-06				134,137
	'99-00				134,137
Escalade ESV	'07				134
	'03-06				134,137
Escalade EXT	'07				148
	'02-06				148
Fleetwood 4dr	'93-95	✓	✓	6	101,111,138
Seville, Seville STS	'98-03				135
	'92-97				133
STS	'06-07				135
SRX	'04-07	✓	✓	10	101,102,121,128,129
XLR	'04-07				135,137
<b>Chevrolet</b>					

Make/Model	Years	961xt/ 910	962xt/ 911	Setting	Fit tips
Astro van	'90-05				137
Avalanche	'02-07				
Aveo 4dr	'07	✓		7	101,102,128,132
	'04-06	✓		8	101,128,132,147
Aveo 5dr	'04-06	✓		10	101,128,132,147
Beretta 2dr	'91-96	✓		6	101,105,132
Blazer 2dr	95-05				
Blazer 4dr	'95-02				
Camaro	'93-02				134
	'82-92				134
Caprice 4dr	'91-96	✓	✓	6	101,105
Caprice wagon	'91-96				134
Cavalier	'88-94	✓	✓	6	101,105
Cavalier 2dr	'95-04	✓		7	101,132,142
Cavalier 4dr	'95-04	✓		7	101,132,142
Cavalier wagon	'91-94	✓	✓	9	101,105,127
Cavalier Z24	'82-94				134
Celebrity wagon	'90-91	✓	✓	8	101,105,125,138
Celebrity, Eurosport	'88-91				135
Cobalt 2dr	'05-07	✓	✓	7	101,102,128
Cobalt 4dr	'05-07	✓	✓	7	101,110,128
Colorado	'04-07				148
Corsica 4dr	'90-95	✓	✓	6	101,105,127
Corsica hatchback	'90-95				134
Equinox	'05-07				134
Full Size Blazer	'91-94				148
Full Size Pickup	'79-87				
Full Size pickup, CK	'88-00				148
HHR	'06-07	✓	✓	11	101,102,121,128
Impala	'06-07	✓	✓	7	101,102,128
	'00-05	✓	✓	6	101,116,128,142
Lumina 2dr	'93-94	✓	✓	6	101,108
	'90-92	✓	✓	6	101,108
Lumina 4dr	'95-01	✓	✓	6	101,108
	'90-93	✓	✓	6	101,108
Lumina APV van	'90-96				134
Malibu	'04-07	✓	✓	7	101,102,128
Malibu 4dr	'97-03	✓		6	101,102,116,125,128,129,132
Malibu Maxx wagon	'04-07	✓	✓	8	101,102,128
Metro 3dr	'98-01	✓		8	101,102,132
Metro 4dr	'98-01	✓		6	101,102,132,140
Monte Carlo	'06-07	✓	✓	7	101,102,128
	'00-05	✓	✓	6	101,102,128
	'95-99				135
Prizm	'98-02	✓		7	101,102,116,128,132
S-10 Blazer 2dr	'83-94				135
S-10 Blazer 4dr	'83-94				135
S-10	'94-03				148
S-10	'83-93				148
Silverado	'07				148
Silverado/Silverado classic	'99-07				148
Spectrum 2dr	'85-88	✓		7	101,102,132,138
Spectrum 4dr	'85-88	✓		6	101,102,132
Suburban	'07				134
	'00-06	✓		10	101,106,121,132,138,143
	'92-99	✓		10	101,106,128,132,143
Tahoe	'07				134
	'00-06	✓		10	101,106,121,132,138,143
Tahoe 2dr	'95-99	✓		10	101,106,128,132,143
Tahoe 4dr	'95-99	✓		10	101,106,128,132,143
Tracker	'99-04				
TrailBlazer 4dr	'02-07				135,137
TrailBlazer EXT 4dr	'02-06				135,137
Uplander	'05-07	✓	✓	11	101,102,121,128

Make/Model	Years	961xt/ 910	962xt/ 911	Setting	Fit tips
Venture	'97-04	✓	✓	10	101,106,121,138
<b>Chrysler</b>					
300	'04-07	✓	✓	7	101,102,128
300M	'98-04	✓	✓	6	101,102,128
Aspen	'07	✓	✓	11	101,102,121,128
Cirrus	'95-00	✓	✓	6	101,106,125
Concorde	'98-04	✓	✓	6	101,102,128
	'93-97				133
Conquest	'85-89				134,135
Crossfire	'04-07				135
LeBaron 4dr	'94-96	✓		6	101,105,132
LeBaron coupe	'85-89	✓		6	101,105,132,138
LHS	'98-02	✓	✓	6	101,102,128
New Yorker Fifth Ave	'92-93				133
	'91				135
New Yorker, LHS	'91-96				133
Pacifica	'04-07				134,135
PT Cruiser	'01-07	✓	✓	10	101,102,121,128,129
Sebring 2dr (hardtop)	'01-06	✓		6	101,102,116,128,132
	'95-00				133,135
Sebring 4dr	'07				135
	'01-06	✓		6	101,102,116,128,132
Town & Country	'01-07	✓	✓	10	101,102,121
	'96-00	✓	✓	10	101,102,121,139
	'91-95	✓	✓	10	101,102,121,139
Voyager/Gr. Voyager	'01-03	✓	✓	10	101,102,121
<b>Daewoo</b>					
Lanos 3dr	'98-02	✓		6	101,102,121,128,132,143
Lanos 4dr	'98-02	✓	✓	7	101,102,128
Leganza 4dr	'98-02	✓	✓	7	101,102,128
Nubira 4dr	'98-02	✓	✓	6	101,106,125,128
Nubira wagon	'98-02	✓	✓	10	101,102,121,128
<b>Dodge</b>					
Aries	'81-89				135
Avenger	'07				check for update
	'95-00				133,135
Caliber	'07	✓	✓	9	101,102,121,128
Caravan/Gr. Caravan	'01-07	✓	✓	10	101,102,121,128
	'96-00	✓	✓	10	101,102,121,139
	'90-95	✓	✓	10	101,102,121,139
Charger	'06-07	✓	✓	7	101,102,128
Colt 2dr	'93-94				133
	'88-89	✓	✓	9	101,102,140
Colt 4dr	'93-95	✓	✓	6	101,102
Colt hatchback	'90-92	✓	✓	8	101,102
Colt Vista wagon	'92-95	✓	✓	9	101,105,121
	'88-91	✓	✓	9	101,102,121
Dakota	'05-07				148
	'87-04				148
Daytona	'90-93	✓		6	101,105,121,132,138
Durango	'04-07	✓	✓	11	101,112,121,125,128
	'98-03	✓	✓	10	101,102,121,128
Dynasty	'90-93	✓	✓	6	101,105
Intrepid	'98-04	✓	✓	6	101,102,128
	'93-97	✓		6	101,102,132
Magnum	'05-07	✓	✓	9	101,102,121,128
Neon 2dr	'95-99	✓		6	101,102,132
Neon 4dr	'00-05				135
	'95-99	✓		6	101,102,132
Nitro	'07	✓	✓	11	101,102,121,128
Omni	'85-90	✓		7	101,109,121,132
Ram	'94-07				148
Shadow 2dr	'87-94				135
Shadow 4dr	'87-94				135

Make/Model	Years	961xt/ 910	962xt/ 911	Setting	Fit tips
Spirit	'91-93	✓		6	101,112,132
Stratus 2dr	'01-06	✓		6	101,102,116,128,132
Stratus 4dr	'01-06	✓		6	101,102,116,128,132
	'95-00	✓	✓	6	101,106,125
<b>Eagle</b>					
Summit 2dr	'93-96				133
	'91-92	✓	✓	8	101,102
Summit 4dr	'93-95	✓	✓	6	101,102
	'89-92	✓	✓	6	101,102
Summit wagon	'92-96	✓	✓	9	101,105,121,138
Talon	'90-98				133,135
<b>Ford</b>					
Aerostar	'92-97	✓		10	101,102,132,138
Aspire 3dr	'95-97	✓		6	101,102,132,138
Aspire 5dr	'95-97	✓		6	101,102,132,138
Bronco, Full Size	'87-96				148
Contour	'95-00	✓	✓	6	101,103,118
Crown Victoria	'92-07	✓		6	101,102,132
Crown Victoria, LTD	'88-91	✓	✓	6	101,108
Escape	'01-07	✓	✓	10	101,102,121,128
Escort 3dr	'91-96	✓	✓	7	101,103,138
Escort 4dr	'97-02	✓		7	101,103,116,125,128,132
	'91-96	✓	✓	7	101,103,138
Escort hatchback	'87-90	✓	✓	8	101,105,138
Escort wagon	'91-99	✓	✓	9	101,102,121,138
Escort GT 2dr	'88	✓	✓	5	101,103,125,138
Excursion	'00-05	✓	✓	10	101,102,121
Expedition	'97-07				135
Expedition EL	'07				134
Explorer 2dr	'96-00	✓	✓	9	101,108,121,139
	'91-95	✓	✓	9	101,102,121,138
Explorer 4dr	'02-05	✓	✓	10	101,102,121,128
	'96-01	✓	✓	9	101,108,121,138
	'91-95	✓	✓	9	101,102,121,138
Explorer Sport	'01-03	✓	✓	9	101,108,121,139
Explorer Sport Trac	'01-05				148
F-150	'04-06				148
F-150	'97-03				148
F-150 SuperCrew	'01-03				148
F-250/350	'99-03				148
Five Hundred	'05-07	✓	✓	8	101,102,116,128
Focus 3dr	'00-07	✓	✓	8	101,102,121,128
Focus 4dr	'00-07	✓	✓	7	101,103,116,125,126,128
Focus 5dr	'02-07	✓	✓	8	101,102,121,128
Focus wagon	'00-07	✓	✓	10	101,102,121,128
Freestar	'04-07	✓	✓	11	101,106,121,128
Freestyle	'05-07				137
Full Size pickup	'79-96				148
Fusion	'06-07	✓		8	101,102,116,128,132
Mustang	'05-07	✓	✓	7	101,102,128
	'99-04				135
	'95-98	✓	✓	6	101,112
Probe	'93-97				133
	'91-92	✓	✓	6	101,108,138
Ranger	'83-07				148
Taurus 4dr	'00-06	✓		6	101,106,126,132
	'96-99	✓		6	101,106,126,132
	'92-95				135
	'86-91	✓		6	101,103,132,138
Taurus wagon	'96-06	✓	✓	9	101,106,121
	'86-95	✓	✓	8	101,102,121,138
Tempo 2dr	'90-94	✓		6	101,108,132,138
Tempo 4dr	'90-94	✓		6	101,108,132,138
Thunderbird	'02-05				135

Make/Model	Years	961xt/ 910	962xt/ 911	Setting	Fit tips
	'89-94	✓		6	101,103,132,138
	'86-87				135
Windstar	'99-03	✓	✓	10	101,102,121,128
	'98				135
	'95-97				135
ZX2	'98-03	✓		7	101,103,116,125,128,132
<b>Geo</b>					
Metro 2dr	'89-94				135
Metro 3dr	'95-97	✓		8	101,102,132
Metro 4dr	'95-97	✓		6	101,102,132,140
	'89-94				135
Prizm	'89-97	✓		6	101,102,132
Spectrum 2dr	'89-89	✓		7	101,102,132,138
Spectrum 4dr	'89-89	✓		6	101,102,132
Storm hatchback	'91-93	✓		8	101,102,132
Storm sport coupe	'90-93				134
Tracker 2dr (hard top)	'89-97				137
<b>GMC</b>					
Acadia	'07	✓	✓	9	101,102,121,128
Canyon	'04-07				148
Classic Sierra	'88-00				148
Denali	'01-04	✓		10	101,106,121,132,138,143
Denali XL	'00-04	✓		10	101,106,121,132,138,143
Envoy	'98-01				137
Envoy/Denali 4dr	'02-07				135,137
Envoy XL	'02-06				135,137
Envoy XUV	'04-05				135,137
Full Size Jimmy	'79-91				148
Full Size Pickup	'79-87				148
Jimmy 2dr	'95-01				134,135
Jimmy 4dr	'95-01				134,135
S-15 Jimmy	'92-94				134
S-15	'85-93				135
Safari van	'90-05				137
Sierra	'07				148
	'99-06				148
Sonoma	'94-04				148
Suburban	'92-99	✓		10	101,106,128,132,143
Yukon	'07				134
	'00-06	✓		10	101,106,121,132,138,143
Yukon	'99	✓		10	101,106,128,132,143
Yukon XL	'07				134
	'00-06	✓		10	101,106,121,132,138,143
<b>Honda</b>					
Accord 2dr	'03-07				135
	'98-02	✓		6	101,110,128,132
	'94-97	✓	✓	5	101,102,138
	'90-93	✓		6	101,102,132
	'86-89	✓	✓	6	101,103,138
Accord 4dr	'03-07	✓	✓	8	101,102,128
	'98-02	✓	✓	7	101,102,128
	'94-97	✓	✓	5	101,102,138
	'90-93	✓		6	101,102,132
	'86-89	✓	✓	6	101,103,138
Accord hatchback	'86-89				134
Accord wagon	'91-93	✓	✓	8	101,102,121,138
Civic 2dr	'06-07				135
	'01-05	✓	✓	6	101,102,128
	'96-00	✓		6	101,102,132
	'92-95	✓		6	101,102,132
Civic Si 3dr	'02-05	✓	✓	8	101,102,121,128
Civic 3dr	'96-00				135
	'92-95	✓		8	101,102,121,132,138

Make/Model	Years	961xt/ 910	962xt/ 911	Setting	Fit tips
Civic 4dr	'06-07				135
	'01-05	✓	✓	6	101,102,128
	'96-00	✓		6	101,102,132
	'92-95	✓		6	101,102,132
	'86-91	✓	✓	6	101,102
Civic wagon	'88-91	✓	✓	9	101,102
CRV	'07				135
	'02-06				
	'97-01				
CRX	'88-91				134
del Sol	'93-97	✓		5	101,110,125,126,132,138
Element	'03-07	✓	✓	11	101,121,128,147
Fit	'07	✓	✓	10	101,102,121,128
Fit sport	'07				134
Insight	'00-06				134,135
Odyssey	'05-07				134
	'95-04				135
Passport	'98-02	✓		8	101,102,121,132,138,143,144
	'94-97				134
Pilot	'03-07				134
Prelude	'97-01				135
	'92-96	✓		4	101,102,132,138
	'88-91	✓		6	101,103,125,132
	'85	✓	✓	6	101,103,125
Ridgeline	'05-07				148
S2000	'00-07				135
Hummer					
H1/Hummer	'93-06				144
H2/H2 SUT	'03-07	✓	✓	11	101,102,121,128,129,144,148
H3	'05-07				
Hyundai					
Accent 3dr	'07				134
	'00-06	✓	✓	8	101,102,128
	'95-99	✓		7	101,108,132,138
Accent 4dr	'06-07	✓	✓	7	101,102,128
	'00-05	✓	✓	7	101,102,128
	'95-99	✓		6	101,108,126,132,138
Azera	'06-07	✓	✓	7	101,102,128
Elantra 4dr	'07	✓	✓	8	101,102,128
	'01-05	✓	✓	7	101,102,128
	'99-00	✓	✓	7	101,102,126,128
	'92-98				133
Elantra wagon	'01-05				134,137
	'97-00				134
Entourage	'07	✓	✓	10	101,102,121,128
Excel 2dr	'90-94	✓		7	101,108,132,138
Excel 4dr	'90-94	✓	✓	6	101,102,138
	'88	✓		8	101,102,121,132
Excel 5dr	'89	✓		8	101,102,121,132,138
Santa Fe	'07				134
	'01-06	✓	✓	9	101,102,121,138
Scoupe	'91-94	✓	✓	5	101,102,138
Sonata	'06-07	✓	✓	7	101,102,128
	'02-05	✓	✓	7	101,102,128
	'99-01	✓		7	101,102,126,128,132
	'95-98	✓		6	101,108,126,132,138
	'92-93				133
Tiburon	'02-07	✓	✓	7	101,102,121,128
	'97-01				133
Tuscon	'05-07	✓	✓	10	101,102,128
Veracruz	'07				134
XG300/350	'01-05	✓	✓	7	101,102,128
Infiniti					
FX35/45	'03-07				134



Make/Model	Years	961xt/ 910	962xt/ 911	Setting	Fit tips
G20	'99-02				136
	'92-96	✓		6	101,103,132,138
G35 2dr	'03-07				135
G35 4dr	'07				check for update
	'03-06	✓		7	101,102,116,128,132
I30	'00-01	✓	✓	6	101,103,125,128
	'95-99	✓	✓	6	101,110,128
I35	'02-04	✓	✓	6	101,103,125,128
J30	'92-98	✓	✓	6	101,103,126
M30	'91-92				134
M35	'06-07	✓	✓	8	101,102,128
M45	'06-07	✓	✓	8	101,103,128
	'03-04				135
Q45	'02-07				133
	'97-01				133
	'90-95	✓	✓	6	101,103
QX4 w/o spare tire	'97-03	✓	✓	10	101,102,121,128
QX56	'04-07	✓	✓	11	101,112,121,128
<b>Isuzu</b>					
Amigo	'99-01				
Ascender	'03-07				135,137
Axiom	'02-04	✓	✓	10	101,102,121,128
Hombre	'96-01				135
I-280/I-290	'06-07				148
I-350/I-370	'06-07				148
I-Mark 2dr	'86-89	✓		7	101,102,132,140
I-Mark 4dr	'86-89	✓		7	101,102,132,140
Impulse	'90-93				134
Oasis	'96-99				134
Truck	'81-87				148
Truck space cap	'89-94				148
Truck std. cab	'88-95				148
Rodeo	'98-04	✓		8	101,102,121,132,138,143,144
	'91-97				
Stylus	'91-93	✓		6	101,102,132
Trooper	'92-02				144
	'84-91				137
<b>Jaguar</b>					
S-Type	'00-03	✓	✓	7	101,102,128
S-Type	'05-07	✓	✓	7	101,102,128
VDP Vanden Plas	'96-02	✓	✓	6	101,128,130
XJ12 4dr	'94	✓	✓	6	101,103
XJ6 4dr	'96-97	✓	✓	6	101,128,130
	'89-95	✓	✓	6	101,103
XJ8	'98-04	✓	✓	6	101,128,130
XJS 2dr	'92-96	✓	✓	6	101,103
XK8 2dr	'97-07				135
X-Type 4dr	'02-07	✓	✓	7	101,102,128
X-Type wagon	'05-07	✓	✓	7	101,102,128
<b>Jeep</b>					
Cherokee	'91-01	✓	✓	8	101,109,121,139
CJ-7	'83-86				
Comanche	'86-94				148
Commander	'06-07	✓	✓	11	101,102,121,128
Compass	'07	✓	✓	9	101,102,121,128
Grand Cherokee	'05-07	✓	✓	10	101,112,121,125,128,129
	'99-04	✓		10	101,102,121,132,138
	'92-98	✓	✓	9	101,105,121,138
Grand Wagoneer	'84-92				137
Liberty	'02-07				
Patriot	'07	✓	✓	11	101,102,121,128
Wrangler	'87-07				
Wrangler Unlimited	'04-07				
<b>Kia</b>					
Amanti	'04-07	✓	✓	7	101,102,128

Make/Model	Years	961xt/ 910	962xt/ 911	Setting	Fit tips
Credos	'98-99				135
Optima 4dr	'07	✓	✓	7	101,102,128
	'01-06	✓	✓	7	101,102,128
Rio 4dr	'06-07	✓	✓	8	101,102,128
	'01-05	✓	✓	7	101,102,128
Rio 5 wagon	'06-07				134
	'02-05	✓	✓	9	101,102,121,128
Rondo	'07	✓	✓	11	101,102,121,128
Sedona	'06-07	✓	✓	11	101,102,121
	'02-05	✓	✓	10	101,102,121,138
Sephia	'98-01	✓		7	101,102,128,132,143
Sephia	'94-97				135
Sorento	'03-07	✓	✓	10	101,103,121,125,128
Spectra 4dr	'04.5-06				137
	'00-04.5	✓		6	101,102,128,132,143
Spectra5	'05-07				134
Sportage	'05-07	✓	✓	10	101,102,121,128
	'95-02				
<b>Land Rover</b>					
Discovery	'95-04				144
Freelander	'02-05				
LR2	'07	✓	✓	10	101,102,121,128
LR3	'05-07	✓	✓	11	101,128,147
Range Rover	'03-07				137
	'87-02				137
Range Rover Sport	'06-07				137
<b>Lexus</b>					
ES250	'90-91				135
ES300	'02-03	✓	✓	7	101,102,128
	'97-01	✓		6	101,103,125,126,132,138
	'92-96	✓	✓	6	101,103
ES330	'04-06	✓	✓	7	101,102,128
ES350	'07				check for update
GS300/350	'06-07	✓	✓	7	101,102,128
	'02-05	✓	✓	6	101,103,138
	'98-01	✓	✓	6	101,103,138
	'93-97				133
GS400	'98-01	✓	✓	6	101,103,138
GS430	'06-07	✓	✓	7	101,102,128
	'02-04	✓	✓	6	101,103,138
GX470	'03-07	✓	✓	11	101,102,121,128
IS300 4dr	'01-05	✓	✓	6	101,102,128
IS300 SportCross	'02-05				134,137
IS 250/350	'06-07	✓	✓	7	101,102,128
LS400	'95-00	✓	✓	7	101,102,128
	'90-94				133
LS430	'01-06	✓	✓	7	101,102,128
LS460	'07	✓	✓	7	101,102,128
LX 450	'96-97				135
LX 470	'98-07	✓	✓	10	101,103,121,125,138
RX300	'98-03	✓		9	101,103,121,127,132,138
RX330/350	'04-07				134
RX400h	'06-07				134
SC300	'98-01				135
SC400	'98-01				135
	'91-93				135
SC430	'02-07				135
<b>Lincoln</b>					
Aviator	'03-05	✓	✓	11	101,106,121,128
Continental	'98-02	✓	✓	6	101,108
	'97-97	✓		7	101,106,132,138
	'90-96	✓		6	101,103,132,138
LS	'00-06	✓	✓	7	101,103,128
Mark LT	'06-07				148

Make/Model	Years	961xt/ 910	962xt/ 911	Setting	Fit tips
Mark VII	'89-92	✓		7	101,109,117,132,138
Mark VIII	'96-99	✓	✓	6	101,103,117,125,128
	'93-95	✓	✓	5	101,103,139
MKX	'07				135
MKZ	'07	✓		8	101,102,116,128,132
Navigator	'98-06				135
Town Car	'91-07	✓	✓	6	101,102,128
Zephyr	'06	✓		8	101,102,116,128,132
<b>Mazda</b>					
3 4dr	'04-07	✓		9	101,102,128,132
3 5dr	'04-07	✓	✓	9	101,102,128
323 3dr	'91-93	✓	✓	7	101,103
5 5dr	'06-07				134,135
6 4dr	'03-07	✓	✓	8	101,102,116,128
6 5dr	'04-07				135
6 wagon	'04-06	✓	✓	10	101,102,128
626	'93-02				135
929	'92-96				133
B-Series	'94-07				
CX-7	'07	✓	✓	9	101,102,121,128
CX-9	'07				135
Miata	'90-05	✓		5	101,103,126,132,138
Millenia	'95-02				133
MPV	'00-06	✓	✓	10	101,102,121,128
	'91-98	✓	✓	10	101,102,121
MX-3	'92-96	✓		6	101,103,121,132
MX-5	'06-07				135
MX-6	'93-97	✓		4	101,108,132
Navajo	'90-95	✓	✓	9	101,102,121,139
	'79-93				135
Protege 4dr	'99-03	✓	✓	7	101,102,116,128
	'95-98	✓	✓	6	101,102,126
	'90-94	✓	✓	6	101,102,126
Protégé 5 wagon	'02-03				135,137
RX-7	'93-95				134
RX-8	'03-07				135
Tribute	'01-06	✓	✓	10	101,102,121,128
<b>Mercedes-Benz</b>					
190, C-Class 4dr	'92-00				133
300 wagon	'88-98	✓	✓	8	101,102,121,138
300 CD	'87-87	✓	✓	6	101,102,138
300 CE	'88-88	✓	✓	6	101,102,138
300 SDL 4dr	'87-87	✓	✓	6	101,109,138
300 SE	'92-99	✓	✓	6	101,102,138
420 SEL	'88-88	✓	✓	6	101,109,138
560 SEC	'89-89	✓	✓	6	101,109,138
560 SEL	'92-96				133
560 SL 2dr	'87-87				133
C-Class 4dr	'05-07	✓	✓	7	101,102,116,128
	'01-04	✓	✓	7	101,102,128
C-Class coupe	'05-07	✓	✓	7	101,102,116,128
	'02-04				134
C-Class wagon	'05-07				134
	'02-04				134
CLS class	'06-07				135
E-Class wagon	'98-05				134
G-Class	'02-05				135
M-Class	'06-07				134,137
	'98-05				134,137
R-class	'06-07	✓	✓	10	101,102,121,128
S-Class, 300-600	'00-05				no fit
<b>Mercury</b>					
Cougar	'99-02				135
	'89-98	✓		6	101,103,125,132,138
	'88				no fit

Make/Model	Years	961xt/ 910	962xt/ 911	Setting	Fit tips
Mariner	'05-07	✓	✓	10	101,102,121,128
Grand Marquis	'92-07	✓		6	101,105,116,132
	'88-89	✓	✓	7	101,108
Marauder	'03-04	✓		6	101,105,116,132
Milan	'06-07	✓		8	101,102,116,128,132
Monterey	'04-07	✓	✓	10	101,102,121,138
Montego	'05-07	✓	✓	8	101,102,116,128
Mountaineer	'02-07	✓	✓	10	101,102,121,128
	'97-01	✓	✓	10	101,102,121
Mystique	'95-00	✓	✓	6	101,103,118
Sable 4dr	'00-05	✓		6	101,106,126,132
	'96-99	✓		6	101,106,126,132
	'92-95				135
	'86-91	✓		6	101,103,132,138
Sable wagon	'96-05	✓	✓	9	101,106,121
	'85-95	✓	✓	8	101,102,121,138
Topaz 4dr	'90-94	✓		6	101,108,132,138
Tracer 4dr	'97-99				135
	'91-96	✓	✓	6	101,102,138
Tracer wagon	'91-99	✓	✓	9	101,102,121,138
Villager	'99-02	✓	✓	10	101,102,121,128
	'93-98	✓		10	101,102,121,126,132,138
Mini					
Cooper	'07				check for update
	'03-06				135
Mitsubishi					
3000GT	'91-99				134,135
Diamante 4dr	'97-04	✓	✓	7	101,102,128
	'91-96	✓	✓	5	101,108,126,138
Diamante wagon	'94-96	✓	✓	8	101,102,121,127
Eclipse	'06-07				134,135
	'95-03				134,135
Endeavor	'04-07	✓	✓	10	101,102,121,128
Expo/Expo LRV	'92-95	✓	✓	9	101,102,121,138
Galant	'04-07	✓	✓	7	101,102,128
	'97-03	✓	✓	6	101,102,128
	'94-96	✓	✓	5	101,102,138
	'90-93	✓	✓	5	101,102,138
	'85-88	✓	✓	5	101,108,114
Galant GTZ	'99-03				135
Lancer 4dr	'02-07	✓	✓	7	101,102,128
Lancer Sportback	'04				134
Mirage 2dr	'00-02	✓	✓	6	101,108,128
	'97-99				133
	'93-96				133
	'89-92	✓	✓	8	101,102
	'85-88				133
Mirage 4dr	'00-01	✓	✓	6	101,108,128
	'97-99				133
	'93-94	✓	✓	5	101,102,138
	'89-92	✓	✓	5	101,102,138
	'87-88				133
Montero	'90-06				
Montero 2dr	'84-90				137
Montero Sport	'97-04	✓		9	101,102,121,132,138
Outlander	'07				134
	'03-06				134
pickup	'83-96				
Precis 2dr	'90-93	✓	✓	7	101,108,138
Raider	'06-07				148
Starion	'85-89				134,135
Nissan					
200SX	'95-98	✓		6	101,102,132,138
240SX coupe	'93-93				134
300ZX	'90-93	✓		6	101,103,128,132,143

Make/Model	Years	961xt/ 910	962xt/ 911	Setting	Fit tips
350Z	'03-06				133
Altima	'07	✓	✓	8	101,102,128
	'02-06	✓	✓	7	101,102,138
	'98-01	✓	✓	6	101,102,139,140
	'93-97	✓	✓	5	101,102,140
Armada	'04-07	✓	✓	11	101,112,121,128
Frontier	'05-07				148
	'98-04				148
Maxima 4dr	'04-07	✓	✓	8	101,102,128
	'00-03	✓	✓	6	101,103,125,128
	'95-99				135
	'87-94	✓	✓	6	101,103
Maxima wagon	'87-88	✓	✓	8	101,102,121,138
Murano	'03-07				134
NX 1600, 2000	'92-94	✓	✓	6	101,103,121
Pathfinder w/spare	'96-01				
Pathfinder	'05-07	✓	✓	11	1,2,21,28
	'96-04	✓	✓	10	101,102,121,128
Pathfinder w/o spare	'92-95	✓		10	101,103,121,127,132,138
	'74-97				135
Pulsar	'87-88	✓		6	101,105,132
Quest	'04-07	✓	✓	11	101,102,121,128
	'99-02	✓	✓	10	101,102,121,128
	'93-98	✓		10	101,102,126,132,138
Sentra 2dr	'95-99	✓		6	101,102,132,138
	'91-94	✓	✓	6	101,102,138
	'90	✓	✓	6	101,102,138
Sentra 4dr	'07	✓	✓	8	101,102,128
	'00-06	✓	✓	7	101,102,116,128
	'95-99	✓		6	101,102,132,138
	'91-94	✓	✓	6	101,102,138
	'90	✓	✓	6	101,102,138
Stanza 4dr	'91-92	✓	✓	6	101,103
Titan Pick-up	'04-07				148
Xterra	'05-07	✓	✓	11	101,102,121,128
	'00-04	✓	✓	9	101,121,125,128,130
Versa 5dr	'07	✓	✓	9	101,102,121,128
Versa 4dr	'07	✓	✓	8	101,102,128
Oldsmobile					
98 Regency	'92-98	✓	✓	7	101,126,130
Achieva 4dr	'92-98	✓	✓	6	101,102
Alero 2dr	'99-04				135
Alero 4dr	'99-04				135
Aurora	'01-03	✓	✓	7	101,102,128
	'95-00				135
Bravada	'02-04				135,137
	'96-01				135,137,144
	'91-94				134
Custom Cruiser wagon	'92-95				135
Cutlass	'97-99	✓	✓	6	101,128,142
Cutlass Ciera 4dr	'92-96				133
Cutlass Cruiser wagon	'90-95				134
Cutlass Supreme 2dr	'88-89				135
Cutlass Supreme 4dr	'92-97	✓		6	101,108,132
Delta 88 Royale	'92-99	✓	✓	6	101,105
Intrigue 4dr	'97-02				135
LSS	'96-99	✓	✓	6	101,105,128
Silhouette	'97-04	✓	✓	10	101,102,121,138
Silhouette	'90-96				137
Peugeot					
405 wagon	'88-91	✓	✓	8	101,102,121,129
Plymouth					
Acclaim	'91-95	✓		6	101,105,132,138
Breeze	'96-00	✓	✓	6	101,105,128
Colt 2dr	'93-94				133

Make/Model	Years	961xt/ 910	962xt/ 911	Setting	Fit tips
Colt 4dr	'93-94	✓	✓	6	101,102
Colt hatchback	'90-92	✓	✓	8	101,102
Colt Vista wagon	'92-94	✓	✓	9	101,105,121
	'89-91	✓	✓	9	101,102,121
Horizon	'85-90	✓	✓	7	101,109,121
Laser	'89-94				134
Neon 2dr	'95-99	✓		6	101,102,132
Neon 4dr	'00-01				135
	'95-99	✓		6	101,102,132
Sundance 4dr	'87-94				134
Voyager/Gr. Voyager	'96-00	✓	✓	10	101,102,121,139
	'90-95	✓	✓	10	101,102,121,139
Pontiac					
Aztec	'01-05	✓		10	101,112,121,125,132,138,143
Bonneville	'00-05				135
	'94-99	✓		6	101,110,116,132
	'87-89				135
Firebird	'79-02				134
G5 coupe	'07	✓	✓	7	101,102,128
G6 coupe	'06-07				134
G6 4dr	'05-07				135
Grand Am 2dr	'98-05	✓		5	101,126,128,132,142
	'92-97				135
	'90	✓	✓	6	101,109
Grand Am 4dr	'99-03	✓		5	101,126,128,132,142
	'92-97				135
Grand Prix 2dr	'97-02	✓	✓	7	101,102,128
	'88-96	✓	✓	6	101,108
Grand Prix 4dr	'04-07	✓	✓	7	101,102,128
	'97-03	✓	✓	7	101,102,128
	'88-96	✓	✓	6	101,108
GTO	'04-06				146
LeMans	'88-93	✓	✓	7	101,102,138
Montana	'99-05	✓	✓	10	101,102,121,138
Montana SV6	'05-06	✓	✓	11	101,102,121,128
Solstice	'06-07				137
Sunbird 2dr	'91-94	✓	✓	6	101,110
Sunbird 4dr	'91-94	✓	✓	6	101,110
Sunfire 2dr	'95-05	✓		7	101,132,142
Sunfire 4dr	'95-02	✓		7	101,132,142
Torrent	'06-07				134
Trans Sport	'97-98	✓	✓	10	101,102,121,138
Trans Sport	'90-96				137
Vibe	'03-07	✓	✓	9	101,102,121,138
Porsche					
Cayenne	'03-07				147
Saab					
9-2x	'04-06				134
9-3 3dr	'99-02	✓	✓	7	101,102,121,138
9-3 4dr	'06-07				134
	'03-05	✓	✓	8	101,102,128
9-3 convertible	'03-05	✓	✓	7	101,102,128
9-3 5dr	'99-02	✓	✓	7	101,102,121,138
9-3 SportCombi	'06-07				134
9-5 4dr	'99-07	✓	✓	7	101,102,128
9-5 wagon	'99-07				137
9-7x	'05-06				135,137
900 2dr	'84-89				135
900 3dr	'94-98	✓	✓	7	101,102,121,138
900 4dr	'89-93	✓	✓	7	101,103
900 5dr	'94-98	✓	✓	7	101,102,121,138
900 convertible	'95	✓		6	101,102,132,138
9000 4dr	'90-97	✓		6	101,102,132
9000 hatchback	'86-97				134
Saturn					

Make/Model	Years	961xt/ 910	962xt/ 911	Setting	Fit tips
Aura	'07				133
Ion 2dr	'03-07	✓	✓	7	101,102,128
Ion 4dr	'03-07	✓	✓	7	101,102,128
LS 4dr	'00-04	✓	✓	7	101,102,128
LW wagon	'00-04	✓	✓	9	101,121,128,142
Relay	'05-07	✓	✓	11	101,102,121,128
SC 2dr	'97-02				135
	'91-96				133
SC 3dr	'97-02				135
Sky	'07				146
SL 4dr	'96-02	✓		6	101,108,132
SL 4dr	'92-95	✓		6	101,105,132
SW wagon	'93-01	✓		8	101,102,121,126,132
Outlook	'07	✓	✓	9	101,102,121,128
Vue	'02-07	✓	✓	11	101,112,121,128
Scion					
tC	'04-07				134
xA	'04-07	✓	✓	9	101,102,121,128
xB	'08	✓	✓	11	101,102,121,128
	'04-07				135
xD	'08	✓		10	101,102,116,121,128,132
Subaru					
Baja	'03-07				148
Forester	'03-07	✓	✓	10	101,102,121,128
	'98-02	✓	✓	9	101,102,128
Impreza 2dr	'95-01	✓		6	101,111,132
Impreza 4dr	'93-01	✓		5	101,102,132,139
Impreza/Outback wagon	'93-99	✓		9	101,102,121,128,132,143
Impreza/ WRX 4dr	'02-07	✓	✓	6	101,102,128
Impreza/ WRX wagon	'02-07	✓	✓	8	101,102,121,127,128
Justy	'89-93	✓	✓	7	101,102,121
Legacy 4dr	'05-07	✓	✓	8	101,128,132,147
	'00-04	✓	✓	7	101,102,128,129
	'95-99	✓		6	101,103,132,138
	'90-94	✓		6	101,103,132
Legacy wagon	'05-07				135
	'00-04	✓	✓	9	101,102,121,128
	'90-94	✓	✓	9	101,102,138
Legacy/Outback wagon	'95-99	✓	✓	8	101,102,121,138
Loyale 2dr	'90-92	✓	✓	6	101,103
Loyale 4dr	'90-92	✓	✓	6	101,103
Loyale wagon	'90-94	✓	✓	9	101,102,121,138
Outback 4dr	'05-07	✓	✓	8	101,128,132,147
	'00-04	✓	✓	7	101,102,128,129
Outback wagon	'05-07				134
	'00-04	✓	✓	9	101,102,121,128
Outback Sport	'02-04	✓	✓	8	101,102,121,127,128
Outback Sport	'00-01	✓		9	101,102,121,128,132,143
SUS 4dr	'98-99				136
SVX	'92-93				135
Tribeca	'06-07				134
Suzuki					
Aerio 4dr	'02-07				101,102,128
Aerio SX 5dr	'02-06				134
Esteem 4dr	'95-02	✓		6	101,102,132,138
Esteem wagon	'98-02	✓		9	101,102,121,128,132
Forenza 4dr	'04-07				135
Forenza wagon	'05-07			8	101,102,128,132
Reno	'05-07	✓	✓	8	101,102,128
Sidekick 2dr	'91-98				
Sidekick 4dr	'91-98				
Swift 2dr	'91-94	✓		5	101,102,132,138
Swift 3dr	'95-01	✓		8	101,102,132
Swift 4dr	'91-94	✓		5	101,102,132,138
SX4	'07	✓	✓	10	101,102,121,128

Make/Model	Years	961xt/ 910	962xt/ 911	Setting	Fit tips
Verona	'04-07	✓	✓	7	101,102,128
Vitara/Grand Vitara	'06-07				
	'99-05				
XL-7	'07	✓	✓	10	101,102,121,128
	'01-06				
<b>Toyota</b>					
4 Runner	'03-07	✓	✓	10	101,104,121,128,145
4 Runner 2dr	'90-95				137
4 Runner 4dr	'96-02	✓	✓	10	101,102,121,127,128
Avalon	'06-07	✓		7	101,102,116,128,132
	'00-05	✓	✓	7	101,102,128
	'95-99				133
Camry 2dr	'92-96	✓	✓	6	101,103,125
Camry 4dr	'07				133
	'02-06	✓	✓	7	101,102,128
	'97-01	✓		6	101,106,125,132,138
	'92-96	✓	✓	6	101,103,125
	'89-91	✓	✓	5	101,108,138
Camry wagon	'92-96	✓	✓	9	101,102,121
	'88-91	✓	✓	9	101,108,121
Celica	'00-05				135,136
Celica 2dr	'94-99	✓		5	101,103,121,132,138
	'90-93	✓	✓	6	101,103,126,138
Celica 3dr	'94-99	✓		5	101,103,121,132,138
	'90-93	✓	✓	6	101,103,126,138
Celica coupe	'86-89	✓	✓	6	101,103
Corolla 4dr	'03-07	✓	✓	8	101,102,128
	'98-02	✓		7	101,102,128,132
	'93-97	✓		6	101,102,126,132
	'89-92	✓		6	101,102,132
Corolla wagon	'93-96	✓	✓	8	101,103,121,138
	88-92	✓	✓	8	101,103,121,138
Echo 2dr	'00-06				135
Echo 4dr	'00-06				135
FJ Cruiser	'06-07				144
Highlander	'01-07	✓	✓	10	101,102,121,127,128
Land Cruiser	'98-07				135
Matrix	'03-07	✓	✓	9	101,102,121,138
MR-2	'90-93				133
MR2 Spyder	'00-05				135
Paseo	'92-97	✓		6	101,102,132,138
Paseo convertible	'97				135
Pickup	'79-89				148
Pickup (small)	'89-96				148
Pickup (Standard)	'89-94				148
Previa	'91-97	✓	✓	9	101,103,125,138
Prius	'04-07	✓	✓	8	101,103,121,125,128
	'01-03				135
RAV4	'06-07				144
	'01-05				
	'96-00				
Sequoia	'01-07	✓	✓	9	101,102,121,127,138
Sienna	'04-07	✓	✓	11	101,102,121,128
	'98-03	✓	✓	10	101,102,121,128
Solara	'04-06	✓		7	101,102,128,132
	'99-03	✓		5	101,102,128,132
Supra	'84-91				135
T100	'93-98				148
Tacoma	'95-07				148
Tercel 2dr	'91-99	✓	✓	6	101,102
	'90	✓		8	101,103,132
Tercel 4dr	'91-99	✓	✓	6	101,102
Tercel wagon	'85-88	✓	✓	9	101,102,139
Tundra	'07				148
	'99-06				148



Make/Model	Years	961xt/ 910	962xt/ 911	Setting	Fit tips
Yaris 2dr	'07	✓	✓	10	101,103,121,125,128
Yaris 4dr	'07	✓	✓	7	101,103,125,128,132
<b>Volkswagen</b>					
Beetle convertible	'03-07				135
Beetle hard top	'98-07				135
Cabriolet	'84-98				137
Corrado	'90-94	✓		6	101,112,121,125,132,138
Eos	'07				check for update
Fox	'89	✓	✓	5	101,102,138
Golf	'89-92	✓		7	101,102,121,132,138
Golf (Type III)	'93-99	✓		8	101,102,132,138
Golf (Type IV)	'99-05	✓	✓	8	101,102,121,128
GTI 3dr	'89-92	✓		7	101,102,121,132,138
Jetta 4dr	'89-92	✓		6	101,103,132,140
Jetta wagon	'01-05	✓	✓	10	101,102,121,128
Jetta (Type III) 4dr	'93-99	✓		6	101,102,132,138
Jetta (Type IV) 4dr	'99-05	✓	✓	7	101,102,128
Jetta (Type V)	'06-07	✓	✓	7	101,102,128
Passat 4dr	'06-07				135
	'98-05	✓	✓	6	101,102,128
	'92-97				133
	'90-91	✓	✓	5	101,103,138
Passat wagon	'07				134
	'02-05	✓	✓	10	101,102,121,128
	'98-01	✓	✓	10	101,102,121,128
	'90-97	✓	✓	9	101,102,121,138
Phaeton	'04-06	✓	✓	7	101,112,128
Rabbit	'06-07	✓	✓	9	101,102,121,128
Scirocco	'87-89	✓	✓	6	101,103,121,138
Touareg	'04-07				134
Vanagon Van	'80-91				146
<b>Volvo</b>					
240/260 4dr	'80-91	✓	✓	6	101,102,138
240/260 wagon	'85-91	✓		10	101,102,121,132,130
740/760 4dr	'90	✓	✓	6	101,102
	'84-89	✓	✓	6	101,109
740/760/940/960 wagon	'84-97	✓		10	101,102,121,132,130
740/960 4dr	'91-97	✓		6	101,102,132,138
850 4dr	'93-97	✓		6	101,102,132,138
850 wagon	'94-97				137
C70	'06-07				137
	'98-05	✓	✓	6	101,110,128
S40	'04-07	✓	✓	7	101,102,128
	'00-03	✓	✓	7	101,108,128
S60	'01-07	✓	✓	7	101,102,128
S70	'98-00	✓		6	101,102,132,138
S80	'07	✓	✓	7	101,102,128
	'99-06	✓	✓	7	101,102,128
S90	'98-00	✓		6	101,102,132,138
V40	'00-04	✓	✓	8	101,102,121,128
V50	'05-07	✓	✓	6	101,102,121,128
V70	'98-07				134,137
V90	'98-00				137
XC90	'03-07				137
501525810					

## **RMS Fit Tips**

- 101 Place top clips in the gap at the front edge of the top of the trunk, hatch or door.
- 102 Place lower clips in the bottom edge of trunk or hatch.
- 103 Set lower clips/hooks into vehicle's left and right tow loops under the rear of the vehicle.
- 104 Set lower clips/hooks into tow loop on the right and frame hole on the left.
- 105 Set lower clips into bottom edge of internal metal bumper.
- 106 Set lower clips/hooks into frame holes.
- 107 Set lower clips into bottom edge of rear doors.
- 108 Set lower clips into frame holes in back of bumper.
- 109 Set lower clips onto bottom edge of bumper.
- 110 Set lower clip/hook onto edge of structural bumper located behind plastic bumper.
- 111 Frame holes are located up high on the backside of bumper.
- 112 Set lower clip/hooks into frame holes in chassis behind bumper.
- 114 Chafe guards required.
- 115 To minimize contact between carrier tow hooks and the bumper, slide the strap through only one end of the chafe guard leaving the other end free to rest between the tow hook and the bumper.
- 116 Caution: Bumper cover may deform with the use of this carrier. Remove carrier when not in use.
- 117 The upper arm of the carrier, between the rubber pads, may come in contact with the center ridge in the trunk lid when carrier is fully mounted.
- 118 Caution: Lower arm of the carrier will mount against the license plate and the lights to the left and right of it.
- 121 Caution: Rear wiper can not be used when carrier is mounted.
- 122 Offset carrier to the right.
- 124 Caution: Rear wiper must be positioned through the upper arm of carrier.
- 125 Important: Always check to make sure there is no contact between the lower straps and the muffler and/or exhaust pipe.
- 126 Caution: The trunk lid may deform slightly with the use of this carrier. Remove carrier when not in use.
- 127 Route top strap under the spoiler on top of the hatch.
- 128 Lower arm of carrier should be positioned on upper tier of bumper.
- 129 Rubber weather stripping at the top of door/hatch will deform over time with the use of this carrier. Remove carrier when not in use.
- 130 Set lower clips/hooks into frame holes in bumper located by the right and left bumper strut.
- 131 Set lower clips/hooks into tow loop on the right and edge of bumper, by the bumper strut, on the left.
- 132 Thule cannot recommend the use of 3-bike carriers on this vehicle.
- 133 Carrier is not recommended because, lower straps can not be mounted in a safe place.
- 134 Carrier is not recommended because, top straps should not be mounted directly to glass or plastic trim covering glass.
- 135 Carrier is not recommended because, the vehicle is unable to support the weight at the point where the carrier must be placed.
- 136 Carrier is not recommended because, upper arm of carrier could damage trunk lid.
- 137 Carrier is not recommended because, top straps can not be mounted in a safe place.
- 138 Lower arm of carrier will rest in the bottom of the license plate well.
- 139 Lower arm of carrier will rest above license plate well.
- 140 Lower arm of carrier will rest at bottom of trunk lip.
- 141 Vehicle not available at time of testing. Please call Thule at 1-800-238-2388 for update. Refer to RMS introduction page for carrier mounting guidelines.
- 142 Set lower clips/hooks on top edge of the metal bumper struts.
- 143 Fit requires the use of versa clip.
- 144 Vehicle can have an externally mounted spare tire prohibiting the use of any strap rack. Check other sections for possible fits.
- 145 Set lower clips/hooks into tow loop on the left and frame hole on the right.
- 146 Carrier is not recommended because it cannot be installed without unwanted contact.
- 147 Set lower clips/hooks in to the tow loop located in the center of the vehicle behind the bumper.