



© 2005. All rights reserved.
Black Box Corporation.

BLACK BOX[®]

NETWORK SERVICES

Black Box Corporation • 1000 Park Drive • Lawrence, PA 15055-1018 • Tech Support: 724-746-5500 • www.blackbox.com • e-mail: info@blackbox.com

FOLLOWME PRINTING SYSTEM

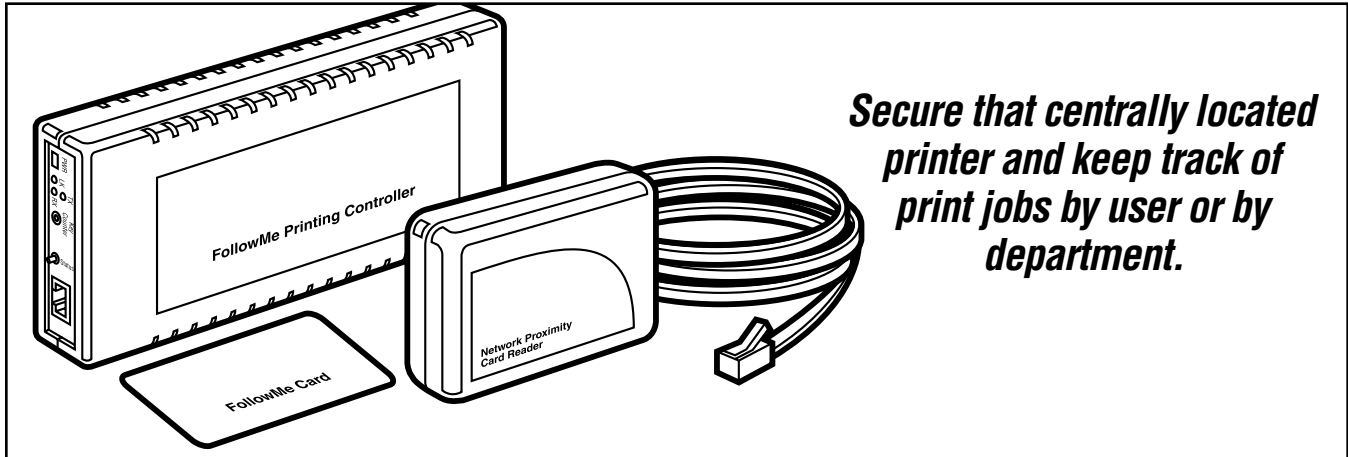

Secure that centrally located printer and keep track of print jobs by user or by department.

Key Features

- ▶ **Improves document security on networked printers that are shared by many users.**
- ▶ **Works with most printing devices.**
- ▶ **Use to monitor and log printer usage.**
- ▶ **Full accounts on a per-user, cost center and printer basis.**
- ▶ **A complete hardware and software package.**
- ▶ **Simple to use and install with intuitive user interface.**
- ▶ **Includes its own 10/100 network connection.**
- ▶ **Extra ID cards available.**

FollowMe Printing not only gives you a practical way to protect the privacy of documents sent to a printer shared by multiple network users, but it's also an ideal tool for monitoring your overall printer usage.

The system enables a print job to be sent from any Windows PC to a secure designated server (running TCP/IP on Windows NT 4, Windows XP, or Windows 2000), which holds the print job until the person who printed it arrives at the printer. The user carries a "proximity" card that identifies them as an authorized user. This card, once recognized by the FollowMe Printing ID card reader, prompts the system to print the document held on the server.

The card-based system improves confidentiality for sensitive documents sent to shared printers, particularly high-end ones located in open-office environments.

Because FollowMe Printing offers a more efficient way of controlling the printing process,

you can reduce associated printing costs and consumables, such as for toner and paper. What's more, FollowMe Printing gives you a low-tech solution that requires minimal setup and ongoing maintenance.

Simple to use and install with its intuitive user interface, FollowMe Printing is compatible with all MFP/MFD devices, and its hardware supports over 99% of printers in the world that have a parallel port.

All hardware and software are included, and the system includes its own network connection.

Setting up the components

FollowMe Printing works on a client-server infrastructure with a central server or servers handling all print jobs in a similar way to a print server.

Setting up FollowMe Printing involves three main procedures:

- Attaching the ID card reader and controller unit to the printer, and adding a 10BASE-T or 100BASE-TX network cable leading from

the controller to a network hub or switch.

- Installing and configuring FollowMe Printing client software on as many PCs on the network as required.
- Installing and configuring the FollowMe Printing Q-Server software onto the designated server PC. Q-Server stores all print jobs uploaded from the client.

The client software

Once installed and configured on any Windows 95/98/Me, Windows NT 4.0, Windows 2000, or Windows XP machine, the FollowMe Printing client software operates transparently to the client PC user.

To print from any application while using the FollowMe Printing system, simply follow your normal print setup procedure and select the required printer. The print job will be automatically directed to the PC running the Q-Server software to await printing, and you can use the client software to view print jobs sent from the PC

that are waiting at the server. Only when you're identified by the ID card reader at the printer will Q-Server proceed to print the job.

A page within the client software application displays all print jobs that are being held on the FollowMe Q-Server and await printing. Once the job is printed, its name disappears from the list. You can delete the print job from the server queue with a simple menu click.

Extra management capabilities are available by accessing the administration window within the client application. Configure the FollowMe Printing client software, for instance, to ask for an ID every time a print job is sent. This option is particularly useful if the PC has multiple users or for sending a print job to the Q-Server for someone else to print out using their ID card.

The controller

The controller is a standalone hardware device that connects to the system's ID card reader. FollowMe Printing offers two possible controller configurations, with the device operating either:

- as a network interface.
- or alongside an existing network interface in which the printer has its own IP address.

In the former configuration, the controller sits between the Ethernet network and the printer, with a cable running between the parallel port on the controller to the parallel port on the printer. In the latter, the controller has its own network connection and IP address.

Because the FollowMe Printing controller has its own Ethernet connection, it doesn't require any changes to your existing printer or its settings.

To connect the system's ID reader to the controller, simply run the attached RJ-11 cable from the reader to the controller's RJ-11 port.

In addition to an RJ-11 ID reader port, parallel port, and RJ-45 Ethernet port as well as a power supply connection, the controller unit features a status

page/reset button and network monitoring LEDs. Use the reset button to return the unit to its factory-default settings. The LEDs provide at-a-glance indications of FollowMe Printing activity: The red LED blinks when the controller transmits data to the network; the green LED blinks when the controller receives data from the network; and the yellow LED informs you that the network link is intact and operating.

The server software

As noted earlier, the FollowMe Q-Server software installs on the computer you designate as the server PC. This software handles all of the user-authentication communication between the printer, client PCs, and the FollowMe Printing hardware.

Foremost, Q-Server enables you to create cost models for printers linked to the FollowMe Printing system. Cost models can then be directly associated with cost centers, which provide you with a method of organizing users and printers into easily managed groups or departments. This way, you can gain an overall picture of the amount of printing costs incurred by specific departments.

These cost models can be created, for example, to set up the cost options for each type of printer in your application. You can set up a cost model for each size of paper that a particular printer can print as well as for black and white, color, black and white duplex, and color duplex jobs.

Once set up, a cost model can be applied to as many printers as required. For instance, if your office has three of the same type of printer, you can expect that the costs per page for each printer will be identical, which means you would need to create and apply only one cost model to all three printers.

But if you have two types of printers (say, one that's for outputting color and one that's for outputting black and white), then the costs per page would differ and you would need different cost models.

The software also features a search utility that enables you to quickly locate cost models from those you've already created.

The Q-Server software also includes password-protected database facilities. The information collated in the database can be used to create and print a variety of reports on FollowMe Printing usage, whether you require a report for a specific user, cost center, printer, or prints made on a specific date. This gives you a versatile tool for monitoring and managing printer usage.

By default, FollowMe is set up to operate with a Microsoft Access database (although it's not necessary to have Access installed on the PC to create reports, you'll need Access to view the database itself). However, you can also use a SQL database with the Q-Server software if you plan to generate large amounts of data.

A user-friendly setup wizard makes adding printers and users to the system easy. In situations where you have to set up a number of users for FollowMe Printing, the Q-Server software provides several shortcut methods that enable multiple users to be added and configured at the same time with the same settings. Import a list of users from the Microsoft domain and apply user configurations to the list as required.

To activate the individual ID cards (which contain unique "hidden" numbers) and assign them to their respective users, click on a "listen" function within the Q-Server software interface and position the card in front of the ID card reader. The system automatically enters each card's number into the FollowMe Printing system.

Specifications

Hardware Requirements: IBM® compatible AT® computers with CD-ROM drives

ID Card Reader Method: Smart card/RF transponder

Operating System Requirements:

Server software: Windows NT® 4.0, Windows® 2000, Windows XP;

Client software: Windows 95/98/Me, Windows NT 4.0, Windows 2000, Windows XP

LAN Type: Ethernet or Fast Ethernet (10 or 100 Mbps)

User Controls: (1) status switch/reset button

Connectors: Controller: To printer: (1) DB25 F; To network: (1) RJ-45

(10/100 Mbps, autosensing); To ID card reader: (1) RJ-11

Indicators: (3) LEDs:

(1) LK (yellow indicates network link is intact);

(1) TX (red indicates transmittal of data to network);

(1) RX (green indicates data received from network)

Power: Controller:

Input: External 110–240 VAC, 50–60 Hz, autosensing;

Output: 5 VDC at 800 mA;

ID card reader: From the attached controller

Size: Controller: 3.5"H x 6.5"W x 1.2"D (8.9 x 16.5 x 3 cm)

Weight: 0.4 lb. (0.2 kg)

Typical FollowMe Printing Application

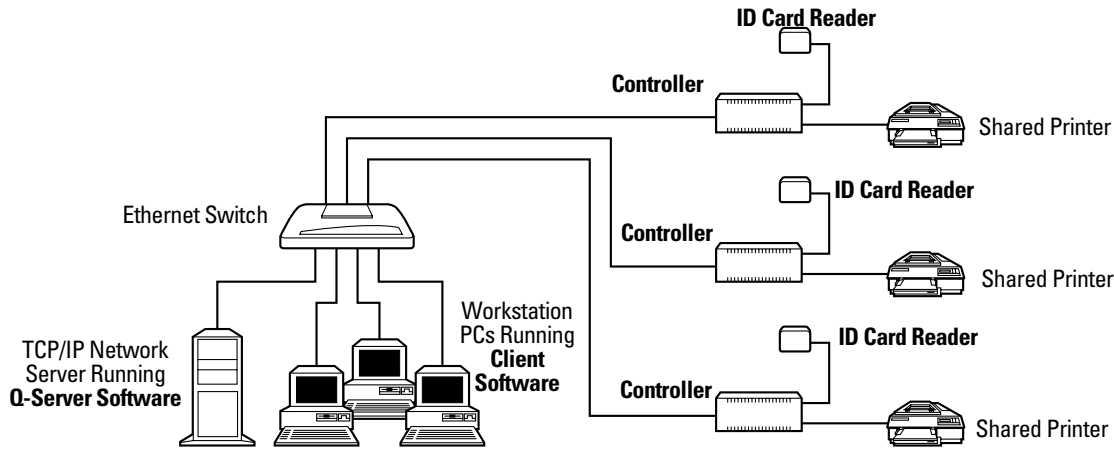

Three controllers/ID card readers deployed in a network switched environment

Why Buy From Black Box? Exceptional Value. Exceptional Tech Support. Period.

Recognize any of these situations?

- You wait more than 30 minutes to get through to a vendor's tech support.
- The so-called "tech" can't help you or gives you the wrong answer.
- You don't have a purchase order number and the tech refuses to help you.
- It's 9 p. m. and you need help, but your vendor's tech support line is closed.

According to a survey by Data Communications magazine, 90% of network managers surveyed say that getting the technical support they need is extremely important when choosing a

vendor. But even though network managers pay anywhere from 10 to 20% of their overall purchase price for a basic service and support contract, the technical support and service they receive falls far short of their expectations—and certainly isn't worth what they paid.

At Black Box, we guarantee the best value and the best support. You can even consult our Technical Support Experts before you buy if you need help selecting just the right component for your application.

Don't waste time and money—call Black Box today.

Package Includes

- Controller unit
- ID card reader on a 5-ft. (1.5-m) cable
- (5) Network proximity ID cards
- AC power adapter (110–230 VAC, 50–60 Hz) with cord
- (1) Networking cable
- Software for client and server on CD (also contains user manuals)

Ordering Information

ITEM	CODE
FollowMe Printing System	LH3800A
<i>To give up to 100 additional users secure access, order...</i>	
FollowMe Printing ID Cards (100)	LH3801A