

Quick Setup Guide

For further information, see the Operating Instructions supplied with the TV. Please retain this guide for your future reference.

Please follow the steps to set up your TV:

- 1 Connecting Your TV (See reverse side)
- 2 Running Initial Setup
- 3 Using the Remote Control

For Your Convenience
Please contact Sony directly if you have questions on the use of your television after reading your Quick Setup Guide and manual. Contact Sony Customer Support at: <http://www.sony.com/tvsupport>
Or to speak with a support representative:
United States 1-800-222-SONY (7669) Canada 1-877-899-SONY (7669)
Please Do Not Return the Product to the Store

Considering the Signal Types

The signal types make a difference in the picture quality. To get the best picture quality, consider the signal types and the connection best suited for that signal type. The chart below shows the different signal types.

Best Signal Performance	Comments	Sources
High Definition Content	Best Picture Quality 16:9 Aspect Ratio	Over-The-Air Antenna HD Cable Subscription HD Satellite Subscription
Digital Content	Good Picture Quality Aspect Ratio based on Program	Over-The-Air Antenna Digital Cable Subscription Digital Satellite Subscription
Analog Content	Original TV format 4:3 Aspect Ratio	Over-The-Air Antenna Cable Subscription

Even with High Definition or Digital Content Subscriptions, not all content may be available in those formats. Each individual program will list if it is available in HD format. Contact your local service provider for details on your service and available programming.

In order to receive High Definition, you should use HDMI or component YPbPr video connection to your video equipment or coaxial to your over-the-air broadcast antenna. Connection using the yellow composite or S VIDEO will not provide HD quality signal to your TV.

To learn more about HDTV, visit: <http://www.sony.com/HDTV>

1 Connecting Your TV

Making Audio/Video Connections

Your new TV includes various types of audio/video inputs and jacks. Use the outputs/inputs that are available on your connecting equipment to provide the best audio/video performance.

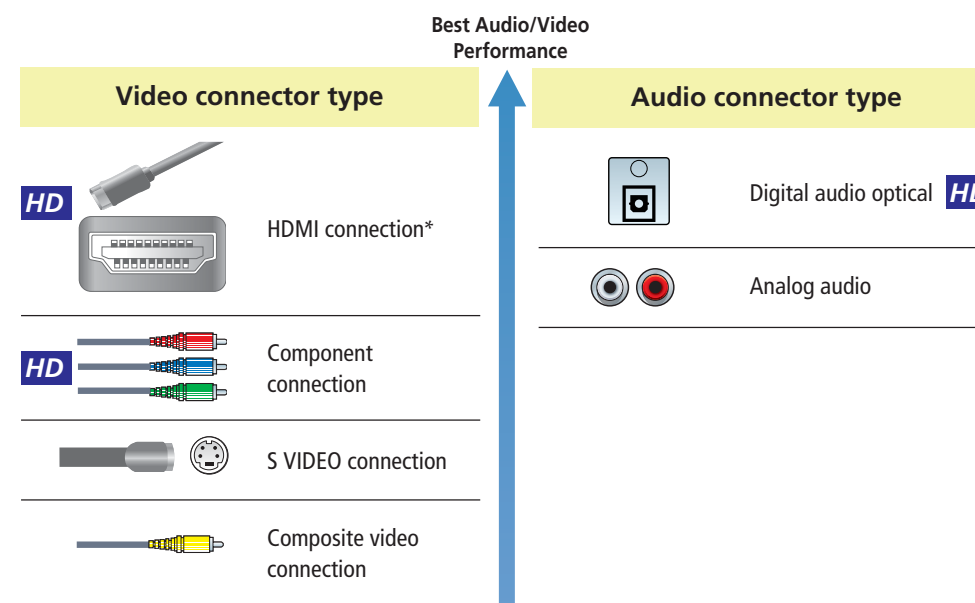

* See the Operating Instructions for connection between HDMI to DVI.

Getting HD Programming

Contact your local cable or satellite TV provider for details on how to upgrade to High-Definition (HD) programming. Additional equipment and subscription fees may apply.

- For information on availability of HD programming using an antenna (HDTV with integrated HD tuner required), visit www.antennaweb.org
- For an interactive guide on cable requirements and how to connect audio and video devices, visit www.ceaconnections.com

Review the following chart to determine which diagram to use to connect the components in your system: Turn off and unplug all components before making connections.

For these components	See reverse side
Cable, Antenna, VCR, DVD Player, PC	A
Cable/SAT, Antenna, Cable Box, Satellite Receiver, VCR, DVD Player, PC, AV Receiver	B
Cable, Antenna, Cable Box, Satellite Receiver, VCR, DVD Player, SAT	C
Cable/SAT, Antenna, HD Cable Box, HD Sat Receiver, DVD Player, AV Receiver (use component), Digital Recorder	D
Cable/SAT, Antenna, HD Cable Box, HD Sat Receiver, VCR, Blu-ray Disc Player, HD DVR	E
Cable/SAT, Antenna, Cable Box, Satellite Receiver, VCR, Sony Dream System	F

2 Running Initial Setup

Use the remote control when following the steps below.

1 Press **POWER** to turn on the TV. The Initial Setup screen appears.

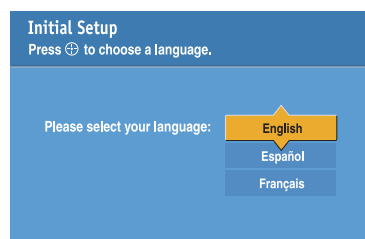

2 Press **▲/▼** to highlight the on-screen display language. Then press **+**. The message "Start auto program now?" appears.

3 Press **▲/▼** to highlight "Yes" then press **+**.

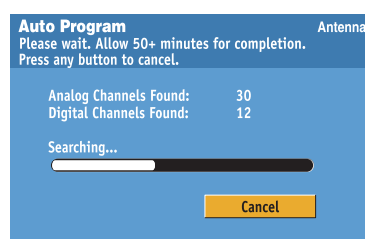

Auto Program performed through Initial Setup will automatically create a list of receivable channels from both VHF/UHF antenna and cable TV channels if both sources are connected.

To run Auto Program again at a later time Refer to the "Initial Setup" and "Auto Program" sections of the Operating Instructions.

3 Using the Remote Control

Programming the Remote Control

The remote control is preset to operate most Sony brand video equipment. Follow the steps below to program your TV's remote control to operate non-Sony video equipment. Find the three-digit code for your equipment from the "Manufacturer's Codes".

Refer to the Operating Instructions for codes.

1 Press and hold the **POWER**, **OVERVIEW** or **SECCABLE** FUNCTION button you want to program on the remote control and press the **RECALL** button simultaneously.

The selected FUNCTION button (**POWER**, **OVERVIEW** or **SECCABLE**) will flash.

2 Enter the three-digit manufacturer's code number using the 0-9 buttons while the FUNCTION button is lit. If the code is not entered within 10 seconds, you must start again from step 1.

3 Press the **MEMO** button while the FUNCTION button is lit.

When the programming is correct, the selected FUNCTION button blinks twice, and when not, blinks five times.

4 Aim your TV's remote control at the equipment, and press the green **TV** button. If you can turn the equipment on and off using the remote control, then the programming is complete. If not, try the next code listed.

For tips on programming the remote control, refer to the "Programming the Remote Control" section of the Operating Instructions.

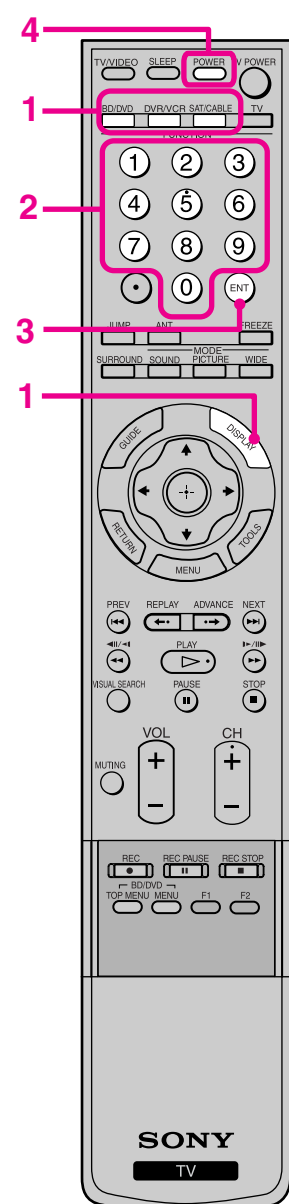

Special Buttons to Remember

WIDE: Depending on the broadcast signal or the way the DVD disc is formatted, you may see bars on the screen or stretched images. Press the WIDE button repeatedly to cycle through different screen modes and select the mode that best meets your TV viewing.

TOOLS: This button provides an alternate way to access some of the features. It also provides direct access to some of the "Settings" menu options. The menus you can select may vary depending on the input signal.

MENU: This button allows you to easily navigate to the most convenient TV functions shown below: External Inputs, Favorites, last viewed TV channel (from Antenna or Cable), and Settings. The Settings option enables you to make adjustments and customize settings for Picture, Sound, Screen, Channel, Parental Lock and more.

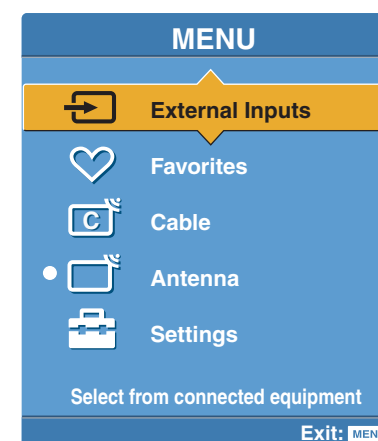
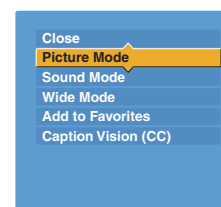

Notes on Your New TV

Picture Quality: The illustrations below highlight the differences between high-definition and standard-definition signals.



Shown above is a high-definition signal with wide mode (16:9 aspect ratio). A high-definition signal fills the screen with a crisp, clear picture with no ghosting and less noise.

Shown below is a standard-definition signal with 4:3 aspect ratio. The picture is fine with the Normal mode, but not as good as the high-definition signal. When a standard-definition signal is viewed in the Zoom or Wide Zoom mode, you can enjoy an enlarged picture on your TV screen, but picture quality may vary.

This TV performs best with high-definition signals. Be sure to read the "Considering the Signal Types" section on this page.

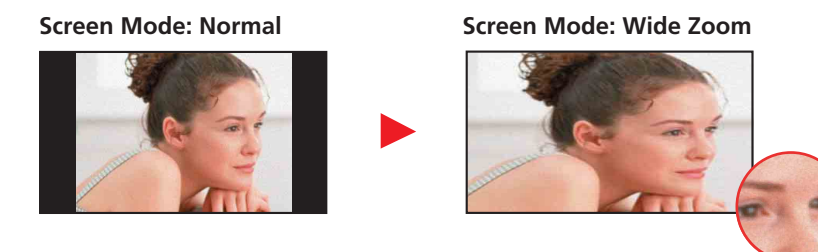

A

Use this diagram if you have;



Cables Required	
Splitter	1
Coaxial	4
Composite	1
Component	1
Audio	3
HD15-HD15	1

If you are connecting to the TV's VIDEO 1 input with equipment that has an S VIDEO output, use the S VIDEO connection instead of the video connection shown here.

If your DVD player has an HDMI output, use that instead of the video and audio connections shown here.

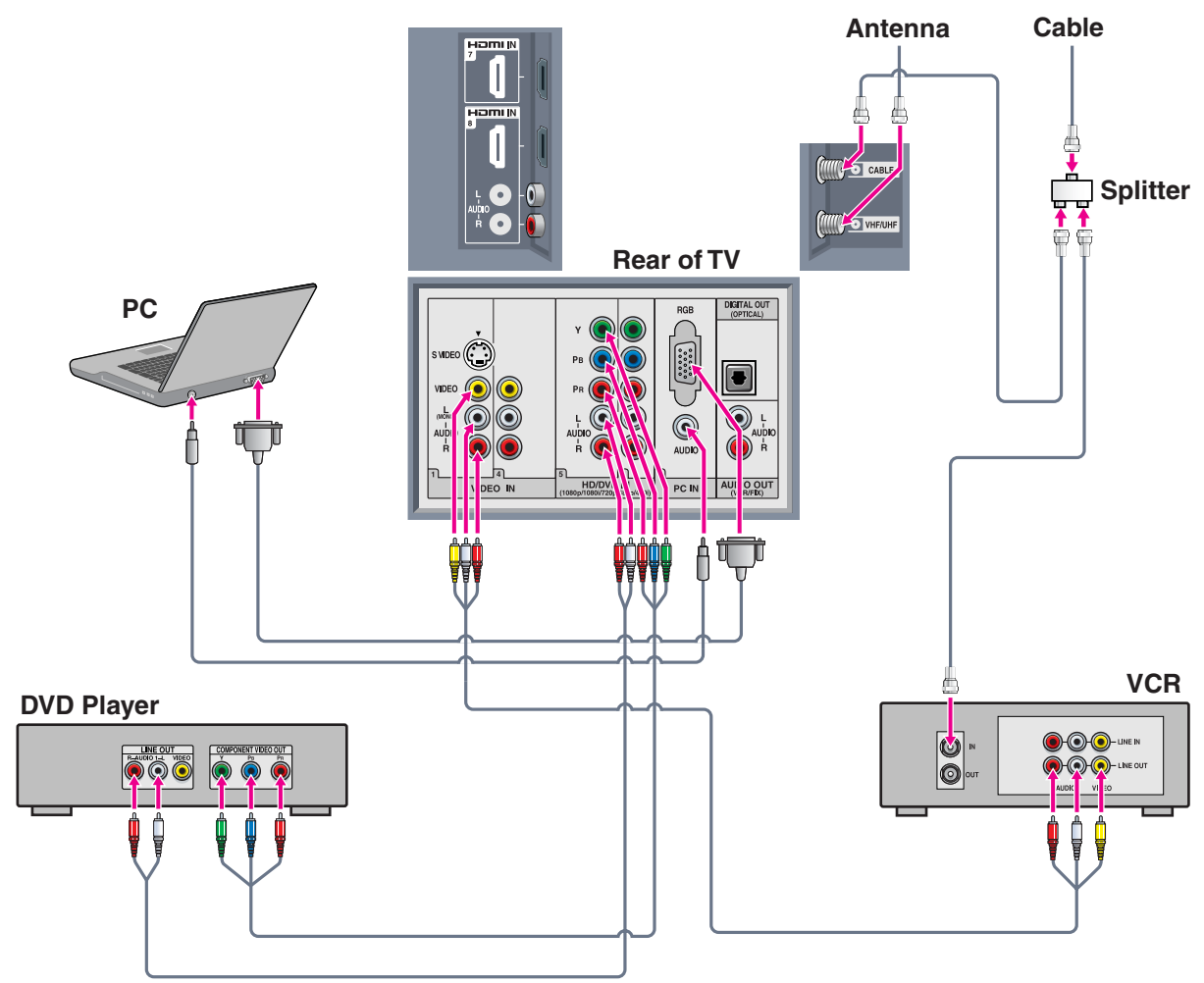

B

Use this diagram if you have; Cable or SAT Antenna



Cables Required	
Splitter	1
Coaxial	6
Composite	2
Component	1
Audio	5
HD15-HD15	1
Digital Optical Audio	2

If you are connecting to the TV's VIDEO 1 input with equipment that has an S VIDEO output, use the S VIDEO connection instead of the video connection shown here.

If you are not using a cable box or satellite receiver, connect your cable to the VCR's RF IN jack.

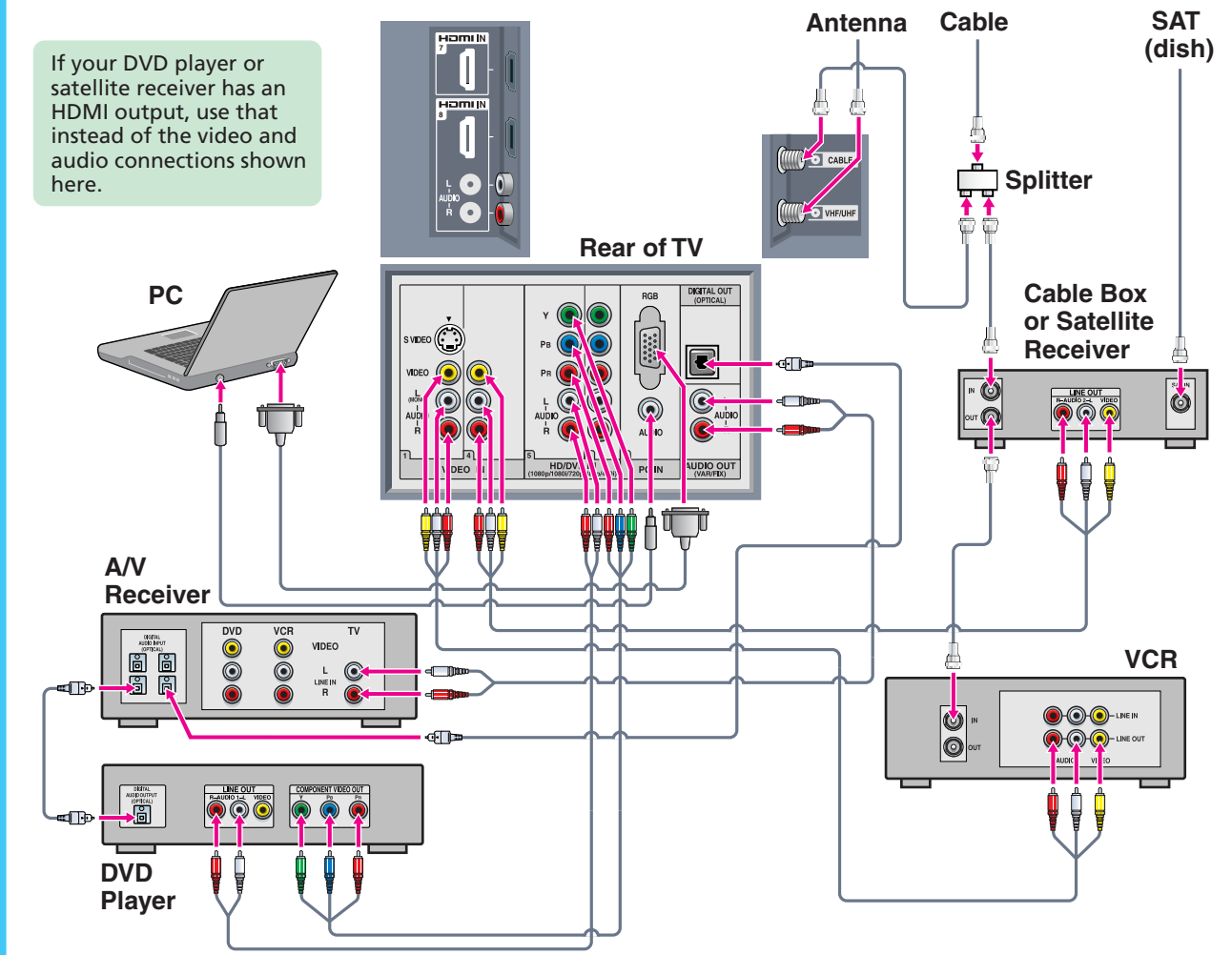

C

Use this diagram if you have; Cable Antenna



Cables Required	
Splitter	1
Coaxial	6
Composite	3
Component	1
Audio	4
HDMI*	1

* See the Operating Instructions for connection between HDMI to DVI.

If you are connecting to the TV's VIDEO 1 input with equipment that has an S VIDEO output, use the S VIDEO connection instead of the video connection shown here.

If you are not using a cable box, connect your cable to the VCR's RF IN jack.

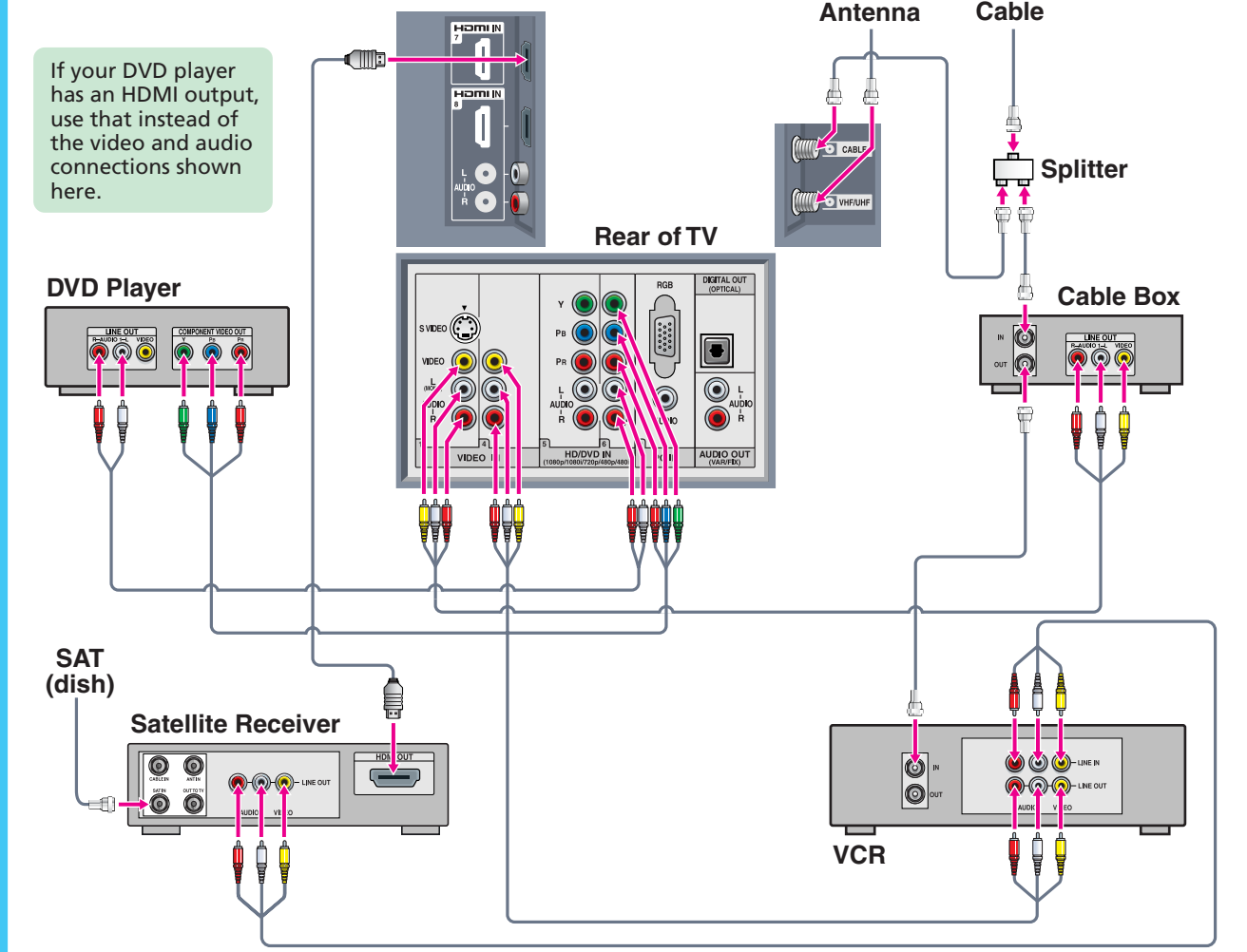

D

Use this diagram if you have; Cable or SAT Antenna



Cables Required	
Splitter	1
Coaxial	6
Component	2
Audio	3
HDMI*	1
Digital Optical Audio	3

* See the Operating Instructions for connection between HDMI to DVI.

If your DVD player or digital recorder has an HDMI output, use that instead of the video and audio connections shown here.

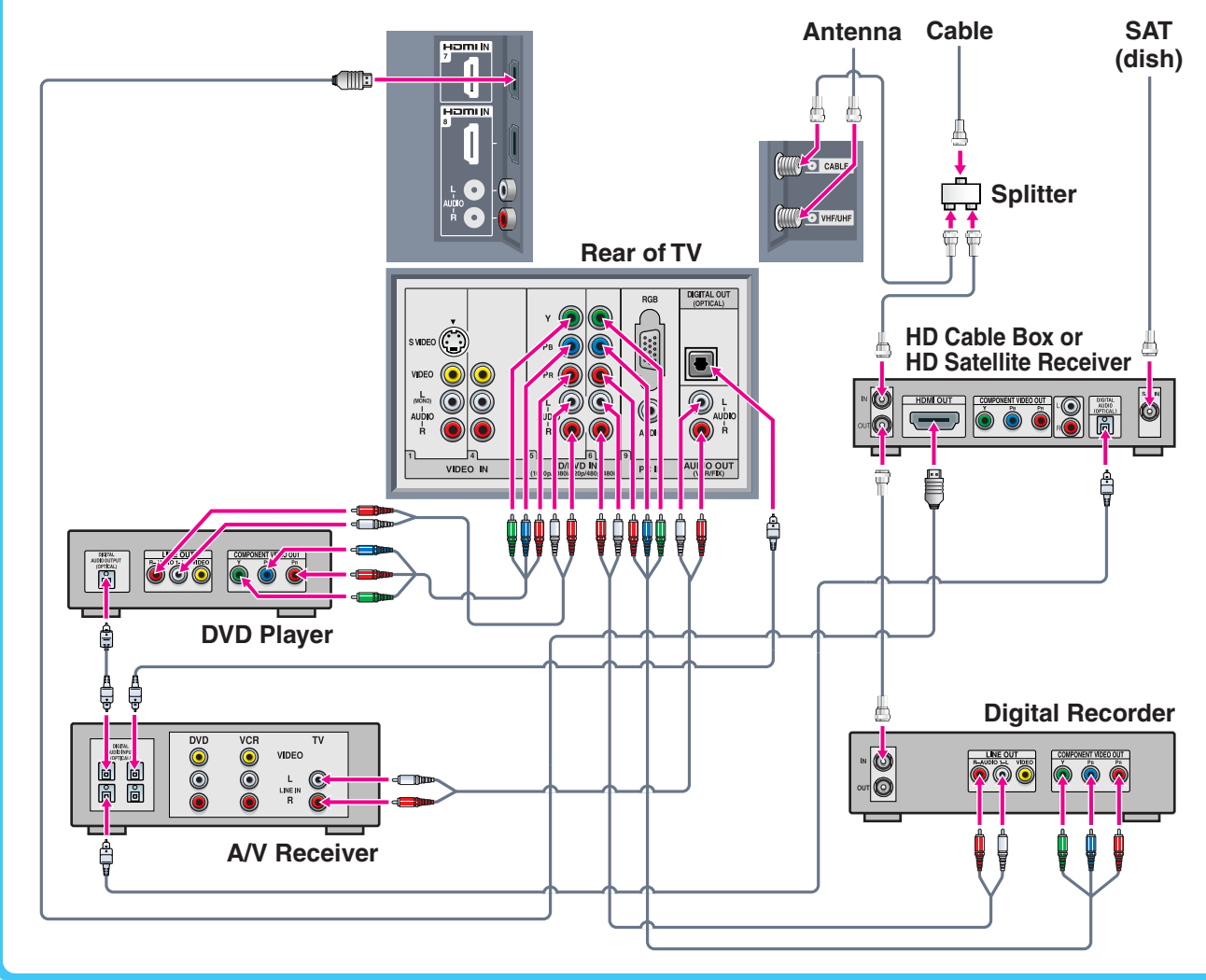

E

For Best HD Picture Quality Use this diagram if you have; Cable or SAT Antenna



Cables Required	
Splitter	1
Coaxial	5
Composite	2
Audio	2
HDMI*	2

* See the Operating Instructions for connection between HDMI to DVI.

If you are connecting to the TV's VIDEO 1 input with equipment that has an S VIDEO output, use the S VIDEO connection instead of the video connection shown here.

For best results, check the cable box's manual for proper setup of the HD output.

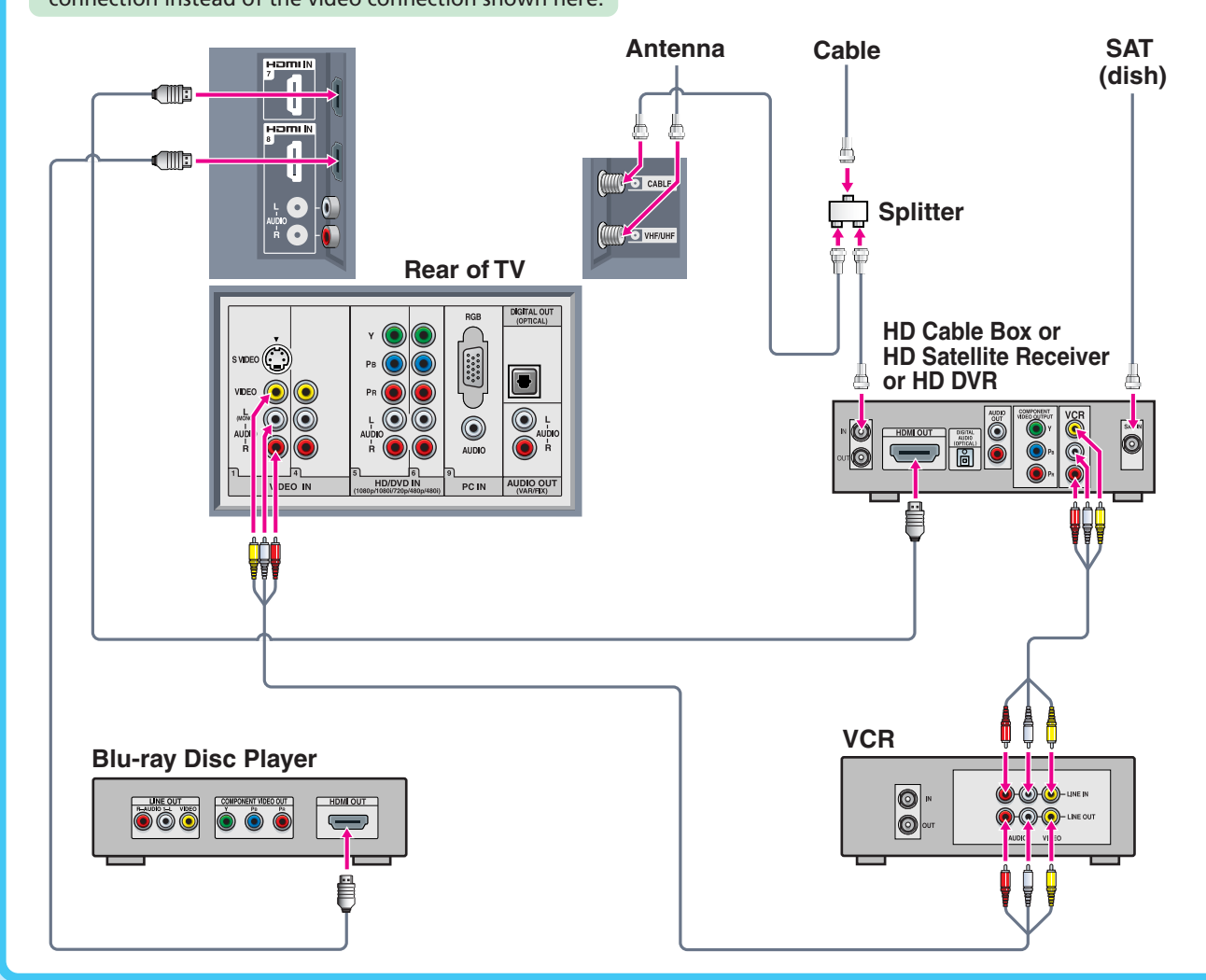

F

Use this diagram if you have; Cable or SAT Antenna Cable Box



Cables Required	
Splitter	1
Coaxial	6
Composite	3
Component	1
Audio	2
Digital Optical Audio	1

If you are not using a cable box or satellite receiver, connect the cable to the VCR's RF IN jack.

