

**SONY®**

2-176-244-12 (1)

**LCD  
WEGA**



**LCD Color TV  
Operating Instructions**

**KLV-23M1**

**Owner's Record**

The model and serial numbers are located at the rear of the TV.  
Record these numbers in the spaces provided below. Refer to them  
whenever you call upon your Sony dealer regarding this product.

Model No. \_\_\_\_\_

Serial No. \_\_\_\_\_

**Contacting Sony**

If, after reading the following instructions, you have additional  
questions related to the use of your Sony TV, please call one of the  
following numbers.

Customers in the continental United States contact the Direct  
Response Center at:

1-800-222-SONY (7669)

Customers in Canada contact the Customer Relations Center at:

1-877-899-SONY (7669)

## WARNING

To reduce the risk of fire or shock hazard, do not expose the TV to rain or moisture.

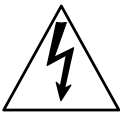
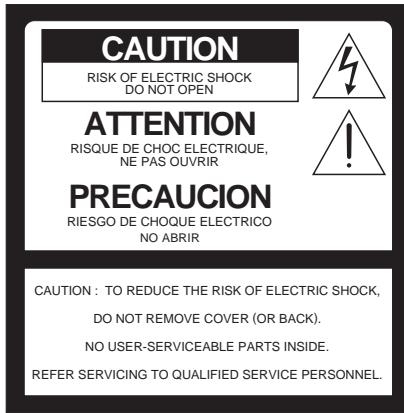

This symbol is intended to alert the user to the presence of uninsulated “dangerous voltage” within the product’s enclosure that may be of sufficient magnitude to constitute a risk of electric shock to persons.



This symbol is intended to alert the user to the presence of important operating and maintenance (servicing) instructions in the literature accompanying the appliance.

## CAUTION

To prevent electric shock, do not use this polarized AC plug with an extension cord, receptacle or other outlet unless the blades can be fully inserted to prevent blade exposure.

### Note on Caption Vision

This television receiver provides display of television closed captioning in accordance with §15.119 of the FCC rules.

### Note to CATV System Installer

This reminder is provided to call the CATV system installer’s attention to Article 820-40 of the National Electrical Code (NEC) that provides guidelines for proper grounding and, in particular, specifies that the cable ground shall be connected to the grounding system of the building, as close to the point of cable entry as practical.

Use of this television receiver for other than private viewing of programs broadcast on UHF or VHF or transmitted by cable companies for the use of the general public may require authorization from the broadcaster/cable company and/or program owner.

## NOTIFICATION

This equipment has been tested and found to comply with the limits for a Class B digital device pursuant to Part 15 of the FCC Rules. These limits are designed to provide reasonable protection against harmful interference in a residential installation. This equipment generates, uses, and can radiate radio frequency energy and, if not installed and used in accordance with the instructions, may cause harmful interference with radio communications. However, there is no guarantee that interference will not occur in a particular installation. If this equipment does cause harmful interference to radio or television reception, which can be determined by turning the equipment off and on, the user is encouraged to try to correct the interference by one or more of the following measures:

- Reorient or relocate the receiving antennas.
- Increase the separation between the equipment and receiver.
- Connect the equipment into an outlet on a circuit different from that to which the receiver is connected.
- Consult the dealer or an experienced radio/TV technician for help.

You are cautioned that any changes or modifications not expressly approved in this manual could void your authority to operate this equipment.

## Safety

- Operate the TV only on 120 V AC.
- The plug is designed, for safety purposes, to fit into the wall outlet only one way. If you are unable to insert the plug fully into the outlet, contact your dealer.
- If any liquid or solid object should fall inside the cabinet, unplug the TV immediately and have it checked by qualified service personnel before operating it further.
- If you will not be using the TV for several days, disconnect the power by pulling the plug itself. Never pull on the cord.
- For details concerning safety precautions, see “Important Safeguards” on page 4.

## Installing

- To prevent internal heat buildup, do not block the ventilation openings.
- Do not install the TV in a hot or humid place, or in a place subject to excessive dust or mechanical vibration.
- Avoid operating the TV at temperatures below 5°C (41°F).
- If the TV is transported directly from a cold to a warm location, or if the room temperature changes suddenly, the picture may be blurred or show poor color due to moisture condensation. In this case, please wait a few hours to let the moisture evaporate before turning on the TV.
- To obtain the best picture, do not expose the screen to direct illumination or direct sunlight. It is recommended to use spot lighting directed down from the ceiling or to cover the windows that face the screen with opaque drapery. It is desirable to install the TV in a room where the floor and walls are not of a reflective material.

(Continued)

## CAUTION

Use the following SONY appliance(s) only with the following WALL-MOUNT BRACKET. Use with other WALL-MOUNT BRACKET may cause instability and result in possible injury.

SONY APPLIANCE MODEL NO.  
KLV-23M1

SONY WALL-MOUNT BRACKET MODEL NO.  
SU-W210

## To Customers

Sufficient expertise is required for installing the specified product. Be sure to subcontract the installation to Sony dealers or contractors and pay adequate attention to safety during the installation.



As an ENERGY STAR® Partner, Sony Corporation has determined that this product meets the ENERGY STAR® guidelines for energy efficiency. ENERGY STAR® is a U.S. registered mark.

## For customers in the United States

This product contains mercury. Disposal of this product may be regulated if sold in the United States. For disposal or recycling information, please contact your local authorities or the Electronics Industries Alliance (<http://www.eiae.org>).

## Trademark Information

WOW, SRS and (●)® symbol are trademarks of SRS Labs, Inc. WOW technology is incorporated under license from SRS Labs, Inc.



This TV incorporates High-Definition Multimedia Interface (HDMI™) technology. HDMI, the HDMI logo and High-Definition

Multimedia Interface are trademarks or registered trademarks of HDMI Licensing LLC.

Wega, Digital Reality Creation, and CineMotion are registered trademarks of Sony Corporation.

# Important Safeguards

Before using your TV, please read these instructions completely, and keep this manual for future reference.

Carefully observe and comply with all warnings, cautions and instructions placed on the unit or described in the operating instructions or service manual.

## WARNING

To guard against injury, the following basic safety precautions should be observed in the installation, use and servicing of the unit.

## Use

### Power Sources

This unit should be operated only from the type of power source indicated on the serial/model plate.

If you are not sure of the type of electrical power supplied to your home, consult your dealer or local power company. For those unit designed to operate from battery power, refer to the operating instructions.



### Grounding or Polarization

This unit is equipped with a polarized AC power cord plug (a plug having one blade wider than the other), or with a three-wire grounding type plug (a plug having a third pin for grounding). Follow the instructions below:

#### For the unit with a polarized AC power cord plug

This plug will fit into the power outlet only one way. This is a safety feature. If you are unable to insert the plug fully into the outlet, try reversing the plug.



If the plug still fails to fit, contact your electrician to have a suitable outlet installed. Do not defeat the safety purpose of the polarized plug by forcing it in.

#### Wall outlet

Do not use a poor fitting outlet.

Insert the plug fully into the outlet. If it is loose, it may cause arcing and result in fire.

Contact your electrician to have the outlet changed.

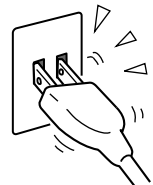

#### Wiring

For your safety, unplug the AC power cord when wiring cables.

#### Electric Shock

Do not touch the AC power cord or the unit with a wet hand.

If you plug/unplug the AC power cord from the unit with a wet hand, it may cause electric shock.



#### Cleaning

Clean the AC power plug regularly.

If the plug is covered with dust and it picks up moisture, its insulation may deteriorate and result in fire. Unplug the AC power plug and clean it regularly.

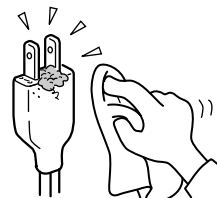

## For the unit with a three-wire grounding type AC plug

This plug will only fit into a grounding-type power outlet. This is a safety feature. If you are unable to insert the plug into the outlet, contact your electrician to have a suitable outlet installed. Do not defeat the safety purpose of the grounding plug.

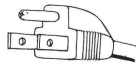

## Overloading

Do not overload wall outlets, extension cords or convenience receptacles beyond their capacity, since this can result in fire or electric shock.

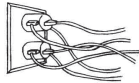

Always turn the unit off when it is not being used. When the unit is left unattended and unused for long periods of time, unplug it from the wall outlet as a precaution against the possibility of an internal malfunction that could create a fire hazard.



If a snapping or popping sound from a TV unit is continuous or frequent while the TV is operating, unplug the TV and consult your dealer or service technician. It is normal for some TV unit to make occasional snapping or popping sounds, particularly when being turned on or off.

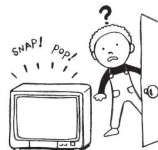

## AC power cord

If you damage the AC power cord, it may result in fire or electric shock.

- Do not pinch, bend, or twist the cord excessively. The core lines may be bared and cut, and cause short-circuit, resulting in fire or electric shock.
- Do not convert or damage the AC power cord or display interface cable.
- Do not put anything heavy on the AC power cord. Do not pull the AC power cord.
- Keep the AC power cord away from heat sources.
- Be sure to grasp the plug when disconnecting the AC power cord.

If the AC power cord is damaged, stop using it and ask your dealer or Sony service center to exchange it.

## Object and Liquid Entry

Never push objects of any kind into the unit through the cabinet slots as they may touch dangerous voltage points or short out parts that could result in a fire or electric shock. Never spill liquid of any kind on the unit.



## Ventilation holes

Do not insert anything in the ventilation holes. If metal or something flammable enters, it may result in fire or electric shock.



## Notes on cleaning of the display

- Be sure to unplug the TV unit before cleaning.
- Minimize contact with the LCD screen surface since the special coating applied may be affected. Use a dry soft cloth when removing dust from the screen.
- Do not use alcohol, benzene, thinner, etc., as it may damage the coating or cause LCD screen deterioration.
- Always use commercially available chemical fibre cleaning cloths in accordance with their supplied instructions.



- Do not allow the LCD screen to come in contact with volatile compounds, such as insecticide. Also, never let the LCD screen come in contact with rubber or plastic products for an extended period of time. This type of contact may damage the coating, or cause the LCD screen to deteriorate.

## Notes on cleaning of the unit

- Wipe the unit gently with a dry soft cloth. Stubborn stains may be removed with a cloth slightly dampened with a solution of mild soap, and then wiped dry.
- Never subject the unit to volatile compounds such as alcohol, benzene, thinner or insecticide. Also, never let the unit come in contact with rubber or plastic products for an extended period of time. This type of contact may damage the coating, and cause the unit to deteriorate, or efface the printing on the unit.

## Attachments

Do not use attachments not recommended by the manufacturer, as they may cause hazards.



## Medical institution

Do not place this unit in a place where medical equipment is in use.

It may cause malfunction of medical instruments.



## Moisture and flammable objects

- Do not use power-line operated unit near water — for example, near a bathtub, washbowl, kitchen sink, or laundry tub, in a wet basement, or near a swimming pool, etc. It may result in fire or electric shock.
- Do not let this unit get wet. Never spill liquid of any kind on the unit. If any liquid or solid object does fall through, do not operate the unit. It may result in electric shock or damage to the unit. Have it checked immediately by qualified personnel.
- To prevent fire, keep inflammable objects or naked lights (e.g. candles) away from the unit.

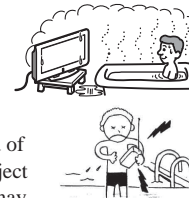

## Accessories

Do not place the unit on an unstable cart, stand, table or shelf. The unit may fall, causing serious injury to a child or an adult and serious damage to the unit. Use only a cart or stand recommended by Sony for the specific model of TV. No part of the TV unit should overhang any edge of the TV cart or stand; any overhanging edge is a safety hazard. An appliance and cart combination should be moved with care. Quick stops, excessive force, and uneven surfaces may cause the appliance and cart combination to overturn.



## Disposal of used batteries

To preserve our environment, dispose the used batteries according to your local laws or regulations.

## Damage requiring service

If the surface of the TV cracks, do not touch it until you unplug the AC power cord.

Otherwise electric shock may result.

(Continued)



## Broken pieces

Do not throw anything at the unit. The screen glass may break by the impact and cause serious injury.

## Cable wiring

Take care not to catch your feet on the cables. It may damage the unit.

## Heat

Do not touch the surface of the TV. It remains hot, even for some time after the TV is turned off.

## Volume adjustment

- Adjust the volume so as not to trouble your neighbours. Sound carries very easily at night time. Therefore, closing the windows or using headphones is suggested.
- When using headphones, adjust the volume so as to avoid excessive levels, as hearing damage may result.

## Disposal of the TV

- Do not dispose the TV with general household waste.
- The LCD contains a small amount of liquid crystal. The fluorescent tube used in this display contains mercury. Follow your local ordinances and regulations for disposal.

## Handling of broken glass and liquid crystal leakage

If the LCD panel gets damaged, crystalline liquid leakage may occur, or scattered broken glass may result. Do not touch broken glass or crystalline liquid (which is toxic), with bare hands as cuts or poisoning/skin irritation may occur. Also, do not let glass fragments or leaked crystalline liquid get into your eyes or mouth. Should either contact your eyes or mouth, rinse the contacted area thoroughly with water and consult your doctor.

## LCD screen

- Although the LCD screen is made with high-precision technology and has effective pixels of 99.99% or more, black dots may appear or bright points of light (red, blue, or green) may appear constantly on the LCD screen. This is a structural property of the LCD panel and is not a malfunction.
- Do not expose the LCD screen surface to the sun. Doing so may damage the screen surface.
- Do not push or scratch the front filter, or place objects on top of the TV. The image may be uneven or the LCD panel may be damaged.
- If the TV is used in a cold place, a smear may occur in the picture or the picture may become dark. This does not indicate a failure. These phenomena improve as the temperature rises.
- Ghosting may occur when still pictures are displayed continuously. It may disappear after a few moments.
- The screen and cabinet get warm when the TV is in use. This is not a malfunction.

## Fluorescent lamp

This TV uses a special fluorescent lamp as its light source. If the screen image becomes dark, flickers, or does not appear, the fluorescent lamp has run down and should be replaced. For replacement, consult qualified service personnel.

# Installation and moving

## Carry the TV in the specified manner

If you carry the TV in a manner other than specified, it may drop and cause serious injury. Be sure to follow the instructions below.

- Carry the TV holding the upper and bottom frames of the TV as illustrated.
- Do not pick up the unit in the middle (where control door is located) or they may damage the control door.
- Hold the TV securely when carrying it.
- As the screen surface of the TV has a special coating, be careful to avoid touching it as much as possible.
- When transporting, do not subject the unit to shocks or vibration, or excessive force.



## Installation

When installing or removing the TV from the wall, be sure to use qualified contractors. Wall mount installation requires the use of a wall-mount bracket. If the TV is installed or removed from the wall by a person other than a qualified contractor, the unit may fall and cause serious injury if the unit is not installed securely.



## Optional accessories

Observe the following when installing the TV using a stand or wall-mount bracket. If the TV is not secured properly, it may fall and cause injury.

- Be sure to follow the operating instructions supplied with your stand or wall-mount bracket when installing the unit.
- Be sure to attach the brackets supplied with your stand or wall-mount bracket.



## Protruding location

Do not install the TV in protruding locations. If you install the unit in the following locations, injury may result.

- Do not install the unit in a location where the unit protrudes, such as a pillar.
- Do not install the unit in a location that may cause facial injury.

## Oils

Do not install this unit in restaurants where oily vapors occur. Dust absorbing oil may enter into the unit and damage the unit.

## Corrosion

If you use this unit near the seashore, salt may corrode metal parts of the unit and cause internal damage or fire.

It may also shorten the life of the unit.

## Ventilation

The slots and openings in the TV are provided for necessary ventilation. To ensure reliable operation of the unit, and to protect it from overheating, these slots and openings must never be blocked or covered.

Unless proper ventilation is provided, the unit may gather dust and get dirty. For proper ventilation, Observe the following:

- Do not install the unit turned backward or sideways.
- Do not install the unit turned over or upside down.



- ❑ Never cover the slots and openings with a cloth or other materials.



- ❑ Never block the slots and openings by placing the unit on a bed, sofa, rug or other similar surface.



- ❑ Never place the unit in a confined space, such as a bookcase or built-in cabinet, unless proper ventilation is provided.

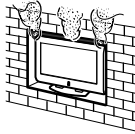

- ❑ Do not place the unit near or over a radiator or heat register, or where it is exposed to direct sunlight.



Leave some space around the unit. Otherwise, adequate air-circulation may be blocked causing overheating and cause fire or damage the unit.

When installing the unit on the wall

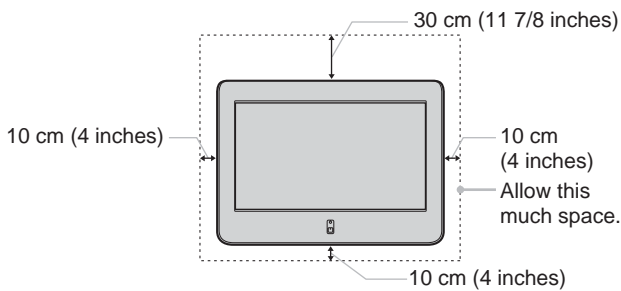

When installing the unit using a stand

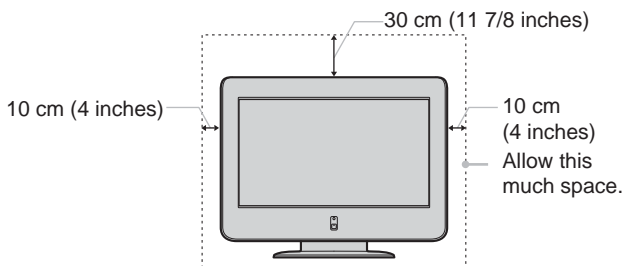

Never install the unit as follows:

Air circulation is blocked.

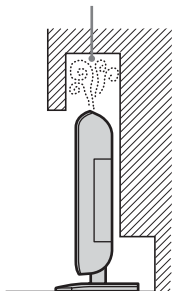

Air circulation is blocked.

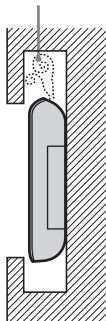

### Outdoor use

Do not install this unit outdoors. If the unit is exposed to rain, it may result in fire or electric shock. If the unit is exposed to direct sunlight, the unit may heat up and it may damage the unit.

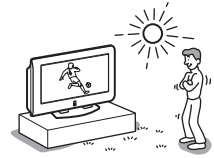

### Vehicle and ceiling

Do not install this unit in a vehicle or hung from the ceiling.

Bumping of the vehicle may cause the unit to fall down and cause injury.

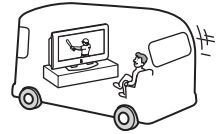

### Ship and vessel

Do not install this unit in a ship or vessel. If the unit is exposed to seawater, it may cause fire or damage the unit.

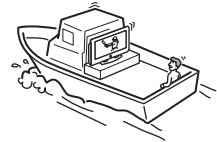

### AC power cord

Unplug the AC power cord when moving the unit.

Do not move the unit with the AC power cord plugged in. It may damage the AC power cord and result in fire or electric shock.

### Fall

Do not hang anything on the unit.

The unit may fall from the stand or wall-mount bracket, causing damage or serious injury.



### Power-Cord Protection

Do not allow anything to rest on or roll over the power cord, and do not place the unit where the power cord is subject to wear or abuse.



# Antennas

## Outdoor Antenna Grounding

If an outdoor antenna is installed, follow the precautions below. An outdoor antenna system should not be located in the vicinity of overhead power lines or other electric light or power circuits, or where it can come in contact with such power lines or circuits.

WHEN INSTALLING AN OUTDOOR ANTENNA SYSTEM, EXTREME CARE SHOULD BE TAKEN TO KEEP FROM CONTACTING SUCH POWER LINES OR CIRCUITS AS CONTACT WITH THEM IS ALMOST INVARIABLY FATAL.

Be sure the antenna system is grounded so as to provide some protection against voltage surges and built-up static charges.

Section 810 of the National Electrical Code (NEC) in USA and Section 54 of the Canadian Electrical Code in Canada provides information with respect to proper grounding of the mast and supporting structure, grounding of the lead-in wire to an antenna discharge unit, size of grounding conductors, location of antenna discharge unit, connection to grounding electrodes, and requirements for the grounding electrode.

## Antenna Grounding According to the National Electrical Code, ANSI/NFPA 70

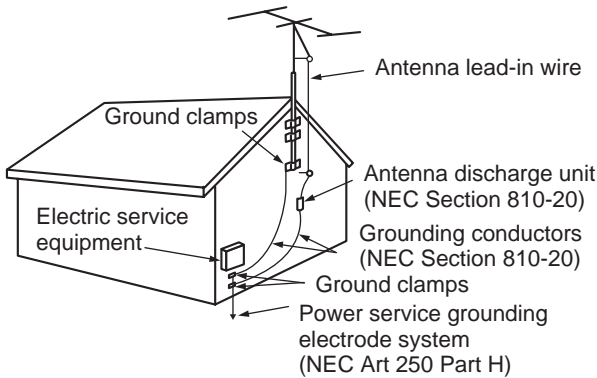

NEC: National Electrical Code

## Lightning

For added protection for this TV during a lightning storm, or when it is left unattended and unused for long periods of time, unplug it from the wall outlet and disconnect the antenna. This will prevent damage to the receiver due to lightning and power-line surges.

# Service

## Damage Requiring Service

Unplug the unit from the wall outlet and refer servicing to qualified service personnel under the following conditions:

- When the power cord or plug is damaged or frayed.
- If liquid has been spilled into the unit.
- If the unit has been exposed to rain or water.
- If the unit has been subject to excessive shock by being dropped, or the cabinet has been damaged.

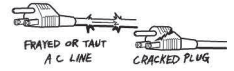

- If the unit does not operate normally when following the operating instructions. Adjust only those controls that are specified in the operating instructions. Improper adjustment of other controls may result in damage and will often require extensive work by a qualified technician to restore the unit to normal operation.
- When the unit exhibits a distinct change in performance, it indicates a need for service.



## Servicing

Do not attempt to service the unit yourself since opening the cabinet may expose you to dangerous voltage or other hazards. Refer all servicing to qualified service personnel.



## Replacement Parts

When replacement parts are required, be sure the service technician certifies in writing that he/she has used replacement parts specified by the manufacturer that have the same characteristics as the original parts.

Unauthorized substitutions may result in fire, electric shock or other hazards.



## Safety Check

Upon completion of any service or repairs to the unit, ask the service technician to perform routine safety checks (as specified by the manufacturer) to determine that the unit is in safe operating condition, and to so certify. When the unit reaches the end of its useful life, ask a qualified service technician to dispose of the unit.





## ***Important Safety Instructions***

- 1) Read these instructions.
- 2) Keep these instructions.
- 3) Heed all warnings.
- 4) Follow all instructions.
- 5) Do not use this apparatus near water.
- 6) Clean only with dry cloth.
- 7) Do not block any ventilation openings. Install in accordance with the manufacturer's instructions.
- 8) Do not install near any heat sources such as radiators, heat registers, stoves, or other apparatus (including amplifiers) that produce heat.
- 9) Do not defeat the safety purpose of the polarized or grounding-type plug. A polarized plug has two blades with one wider than the other. A grounding type plug has two blades and a third grounding prong. The wide blade or the third prong are provided for your safety. If the provided plug does not fit into your outlet, consult an electrician for replacement of the obsolete outlet.
- 10) Protect the power cord from being walked on or pinched particularly at plugs, convenience receptacles, and the point where they exit from the apparatus.
- 11) Only use attachments/accessories specified by the manufacturer.
- 12) Use only with the cart, stand, tripod, bracket, or table specified by the manufacturer, or sold with the apparatus. When a cart is used, use caution when moving the cart/apparatus combination to avoid injury from tip-over.



- 13) Unplug this apparatus during lightning storms or when unused for long periods of time.
- 14) Refer all servicing to qualified service personnel. Servicing is required when the apparatus has been damaged in any way, such as power-supply cord or plug is damaged, liquid has been spilled or objects have fallen into the apparatus, the apparatus has been exposed to rain or moisture, does not operate normally, or has been dropped.



# Table of Contents

---

## Installing the TV

<b>Unpacking</b> .....	13
<b>Overview of the Remote Control</b> .....	13
Remote Control Descriptions .....	14
Programming the Remote Control ...	16
Using your Remote Controls with Other Equipment .....	18
<b>Overview of the TV Controls and Connectors</b> .....	20
Front Panel Controls and Connectors .....	20
Rear Panel Connectors .....	21
Attaching and Removing the Cable Cover .....	22
Bundling Cords and Cables .....	23
Adjusting the Viewing Angle of the TV .....	23
Carrying the TV .....	23

---

## Connecting and Setting the TV

<b>Basic Connections (Connecting Cable or an Antenna)</b> .....	24
Connector types .....	24
Connecting directly to cable or an antenna .....	24
Cable box connections .....	24
Connecting Optional Equipment .....	25
Connecting the Power Cord .....	25
<b>Connecting a VCR and Cable TV</b> .....	26
<b>Connecting a Satellite Receiver</b> .....	27
<b>Connecting a Satellite Receiver and a VCR</b> .....	28

<b>Connecting an AV Receiver</b> .....	29
<b>Connecting a DVD Player with Component Video Connectors</b> .....	30
<b>Connecting a DVD Player with S Video and Audio Connectors</b> .....	31
<b>Connecting a Digital Cable Box</b> .....	32
<b>Connecting a Digital Satellite Receiver</b> .....	33
<b>Connecting a Digital Satellite Receiver with HDMI Connector</b> .....	34
<b>Setting the TV</b> .....	36
Setting the Channels .....	36
<b>Using the Menu</b> .....	38
<b>Selecting the On-screen Menu Language</b> .....	39

---

## Watching the TV

<b>Watching the TV</b> .....	41
Watching with closed caption .....	42
<b>Selecting the Picture Mode</b> .....	43
<b>Selecting the Effect Mode</b> .....	44
<b>Using the Wide Screen Mode</b> .....	45
Changing the Wide Screen Mode ...	45
Changing the Wide Screen Mode using the menu .....	47
<b>Using the Freeze Function</b> .....	49
<b>Setting the Video Inputs</b> .....	50
<b>Using the Video Label and Skip Feature</b> .....	51
<b>Using Favorite Channels</b> .....	52
Setting your favorite channels .....	52
Watching favorite channels .....	53
<b>Using the Channel Label Feature</b> .....	53

(Continued)

---

## Using Advanced Features

<b>Adjusting the Picture Position</b>	
Vertically .....	55
<b>Adjusting the Picture Position</b>	
Horizontally .....	56
<b>Adjusting the Picture Quality .....</b>	<b>57</b>
<b>Adjusting the Sound Quality .....</b>	<b>59</b>
<b>Selecting Stereo or</b>	
<b>Bilingual Programs .....</b>	<b>60</b>
Selecting stereo or bilingual programs	
using the menu .....	61
<b>Selecting the TV Speakers or an External</b>	
<b>Amplifier to Listen to the TV .....</b>	<b>61</b>
<b>Selecting How to Control the Volume of</b>	
<b>the TV's Speakers .....</b>	<b>62</b>
<b>Using the Parental Control Feature .....</b>	<b>63</b>
Activating the Parental Control	
feature .....	64
Selecting a Custom Rating .....	66
<b>What the Ratings Mean .....</b>	<b>68</b>
Ratings in the U.S.A. ....	68
Ratings in Canada .....	70
<b>Turning Off the TV Automatically .....</b>	<b>72</b>

---

## Additional Information

<b>Troubleshooting .....</b>	<b>73</b>
Self-diagnosis function .....	73
Trouble symptoms and remedies .....	73
<b>Specifications .....</b>	<b>75</b>
<b>Index .....</b>	<b>76</b>

# Installing the TV

## Overview of the Remote Control

Insert two size AA batteries (supplied) by matching the **+** and **-** on the batteries to the diagram inside the remote control's battery compartment.

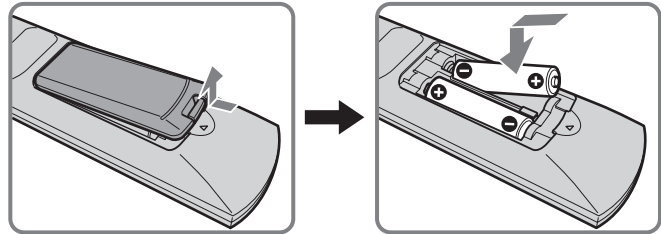

## Unpacking

When you unpack this unit, make sure it includes the following:

Remote control (1) and size AA batteries (2)

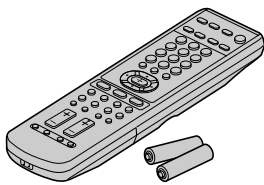

AC power cord (1)

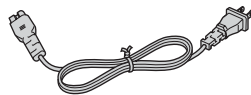

75-ohm coaxial cable (1)

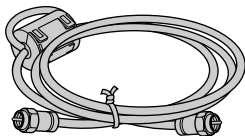

### Notes

- Do not detach the ferrite core from the cable.
- The ferrite core is attached to one end of (not the center of) the cable. When connecting the cable to the TV, insert the end with the ferrite core into the VHF/UHF jack.

Operating Instructions (1)

Quick Setup Guide (1)

Warranty Card (1)

### Notes

- Remove the batteries to avoid damage from possible battery leakage whenever you anticipate that the remote control will not be used for an extended period.
- Handle the remote control with care. Avoid dropping it, getting it wet, or placing it in direct sunlight, near a heater or where the humidity is high.
- The supplied remote control can be programmed to operate most video equipment (see "Programming the Remote Control" on page 16).

# Remote Control Descriptions

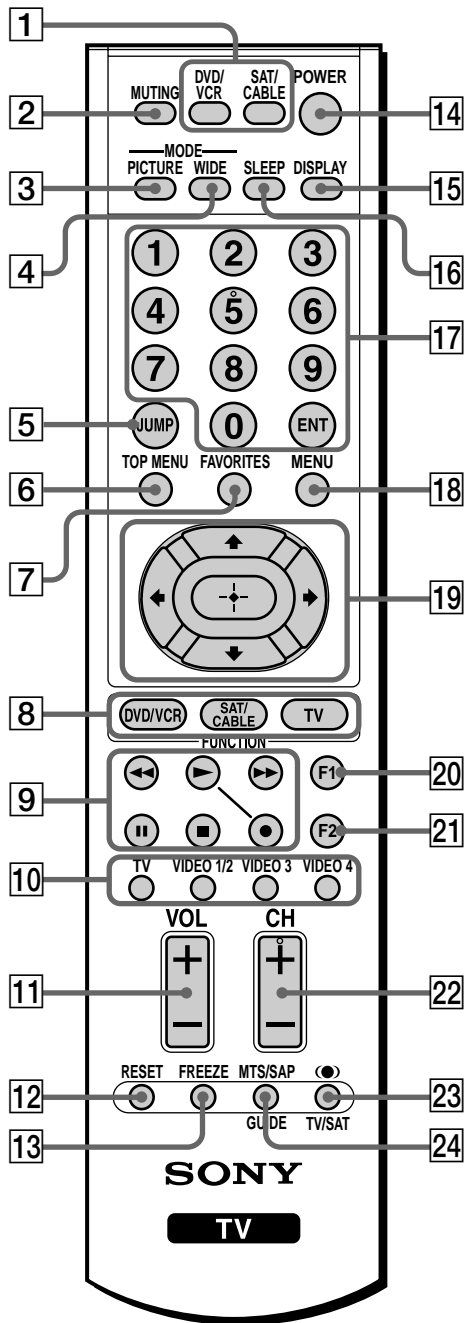





**Tip**

The MTS/SAP button, the number 5 button and the CH + button have a tactile dot. Use the tactile dot as a reference when operating the TV.

Button	Description
1 DVD/VCR, SAT/CABLE Buttons	Press to turn on and off the equipment you have programmed into the remote control. For details, see "Programming the Remote Control" on page 16. <b>DVD/VCR:</b> Press to turn on and off the video equipment. <b>SAT/CABLE:</b> Press to turn on and off the satellite receiver or cable box.
2 MUTING	Press to mute the sound. Press again or press VOL + to restore the sound.
3 PICTURE	Press repeatedly to cycle through the available video picture modes: Vivid, Standard and Pro. The video picture modes can be also accessed in the Video menu. For details, see "Adjusting the Picture Quality" on page 57.
4 WIDE	Press repeatedly to step through the Wide Screen Mode settings: Wide Zoom, Normal, Full and Zoom. The Wide Screen Mode settings can be also accessed in the Screen menu. For details, see pages 45 and 47.
5 JUMP	Press to jump back and forth between two channels. The TV alternates between the current channel and the last channel that was selected.
6 TOP MENU	Press to display the top menu of your DVD/VCR.
7 FAVORITES	Press to display the Favorite Channels list. For details, see page 52.
8 FUNCTION Buttons	Press to have the remote control operate the equipment you want. For details, see "Programming the Remote Control" on page 16.
9 DVD/VCR Operating Buttons	When FUNCTION is switched on DVD/VCR, these buttons operate the video equipment you have programmed into the remote control. For details, see "Using your Remote Controls with Other Equipment" on page 18.
	◀◀ Rewind
	▶ Play
	▶▶ Fast forward
	Pause
	■ Stop
	● Record



Button	Description
<b>10</b> Input Select Buttons	Press to select the video equipment connected to the TV's video inputs. <b>TV:</b> Press to select the TV to watch the TV programs. <b>VIDEO 1/2:</b> Press repeatedly to cycle through the video equipment connected to the VIDEO 1 IN and the VIDEO 2 IN. If the video label is selected as "Skip," the selected input will be skipped from the cycle. <b>VIDEO 3:</b> Press to select the video equipment connected to the HD/DVD 3 IN. <b>VIDEO 4:</b> Press to select the video equipment connected to the HDMI 4 IN.
<b>11</b> VOL +/-	Press to adjust the volume.
<b>12</b> RESET	Press to reset the settings to the factory defaults. See pages 58 and 60. Also used to clear Channel Label.
<b>13</b> FREEZE	Press to freeze the picture. Press again to restore the picture. For details, see "Using the Freeze Function" on page 49.
<b>14</b> POWER	Press to turn on and off the TV.
<b>15</b> DISPLAY	Press once to display the current channel number/channel label and the Wide Screen Mode, or the current video input number/video label and the Wide Screen Mode. When the display is turned on, the current channel number/channel label or video input number/video label remains displayed. Press it again to turn the display off.
<b>16</b> SLEEP	Press repeatedly until the TV displays the time in minutes (15, 30, 45, 60 or 90) that you want the TV to remain on before shutting off. To cancel Sleep Timer, press SLEEP repeatedly until Sleep Off appears.
<b>17</b> 0 - 9 ENT	Press 0 - 9 to select a channel; the channel changes after 2 seconds. Press ENT to change channels immediately.
<b>18</b> MENU	Press to display the menu. Press again to exit from the menu. For details, see page 38.
<b>19</b>  	Press  to move the on-screen cursor. To select an item, press  .
<b>20</b> F1	Press to select the function of your video equipment which is programmed on the TV's remote control.
<b>21</b> F2	Press to select the function of your video equipment which is programmed on the TV's remote control.

Button	Description
<b>22</b> CH +/-	Press to scan through channels. To scan quickly through channels, press and hold down either CH + or CH -.
<b>23</b> 	Press to select the sound effect modes: SRS WOW, Off. The sound effect modes can be also accessed in the Audio menu. For more details, see "Selecting the Effect Mode" on page 44.  When SAT/CABLE (FUNCTION) is on  TV/SAT Press to switch between the TV and the satellite receiver.
<b>24</b> MTS/SAP	Press repeatedly to cycle through the Multi-channel TV Sound (MTS) options: Stereo, Auto SAP (Second Audio Program), and Mono. The MTS setting can be also accessed in the Audio menu. For more details, see "Selecting Stereo or Bilingual Programs" on page 60.  When SAT/CABLE (FUNCTION) is on  GUIDE Press to display the program guide of your satellite program provider.

## Programming the Remote Control

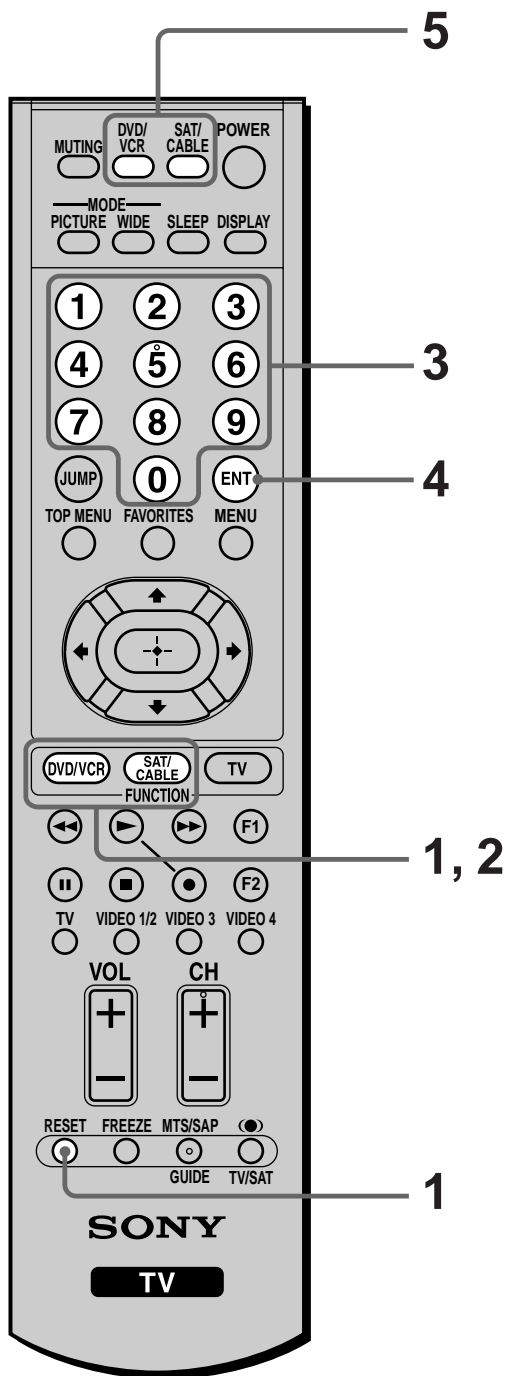

The remote control is preset to operate Sony brand video equipment.

Sony Equipment	Programmable Code Number
DVD/VCR	601 (Sony Dream System)
SAT/Cable	801 (Sony Satellite Receiver)

If you have video equipment other than Sony brand that you want to control with the TV's remote control, use the following procedures to program the remote control.

### Note

The equipment must have infrared (IR) remote capability in order to be used with this remote control.

From the "Manufacturer's codes" listed on page 17, select the three-digit code number for the manufacturer's code of your equipment. If more than one code number is listed, try entering them one by one until you come to the correct code for your equipment. Use the code number to complete the following procedure.

- 1 Press the DVD/VCR (FUNCTION) and RESET buttons simultaneously, or press the SAT/CABLE (FUNCTION) and RESET buttons simultaneously. DVD/VCR and SAT/CABLE buttons flash.
- 2 Press the function button you want to program.
  - To program video equipment**  
Press DVD/VCR (FUNCTION).
  - To program a cable box or a satellite receiver**  
Press SAT/CABLE (FUNCTION).
- 3 Enter the three-digit manufacturer's code number using the 0 - 9 buttons.
- 4 Press ENT (enter).
- 5 To check if the code number works, aim the TV's remote control at the equipment and press DVD/VCR and/or SAT/CABLE (POWER) that corresponds with that equipment. If it responds, the programming is completed. If not, try using the other codes listed for that manufacturer.

### Tips

- If you enter a new code number, the code number you previously entered at that setting is erased.
- In some rare cases, you may not be able to operate your equipment with the Sony remote control. In this case, use the equipment's own remote control unit.

## Manufacturer's Codes

### DVD Players

Manufacturer	Code
Sony	751
General Electric	755
Hitachi	758
JVC	756
Magnavox	757
Mitsubishi	761
Panasonic	753
Philips	757
Pioneer	752
RCA/PROSCAN	755
Samsung	758
Toshiba	754
Zenith	760

### DVD Changers

Manufacturer	Code
Sony	765
Panasonic	766

### DVD/VCR Combo Units

Manufacturer	Code
Sony	767
Zenith	768
Toshiba	773
Samsung	774
JVC	775
Broksonic	776
Panasonic	777

### HDD/DVD Combo Units

Manufacturer	Code
Sony	770, 771, 772

### 5.1ch DVD AV System

Manufacturer	Code
Sony (DAV)	601, 602, 603, 604

### AV Receivers

Manufacturer	Code
Sony	764

### VCRs

Manufacturer	Code
Sony	301, 302, 303
Admiral (M. Ward)	327
Aiwa*	338, 344
Audio Dynamic	314, 337
Broksonic	319, 317

Manufacturer	Code
Canon	309, 308
Citizen	332
Craig	302, 332
Curtis Mathes	304, 338, 309
Daewoo	341, 312, 309
DBX	314, 336, 337
Dimensia	304
Emerson	319, 320, 316, 317, 318, 341
Fisher	330, 335
Funai	338
General Electric	329, 304, 309
Go Video	322, 339, 340
Goldstar	332
Hitachi	306, 304, 305, 338
Instant Replay	309, 308
JC Penney	309, 305, 304, 330, 314, 336, 337
JVC	314, 336, 337, 345, 346, 347
Kenwood	314, 336, 332, 337
LG	332
LXI (SEARS)	332, 305, 330, 335, 338
Magnavox	308, 309, 310
Marantz	314, 336, 337
Marta	332
Memorex	309, 335
Minolta	305, 304
Mitsubishi/MGA	323, 324, 325, 326
Multitech	325, 338, 321
NEC	314, 336, 337
Olympic	309, 308
Optimus	327
Orion	317
Panasonic	308, 309, 306, 307
Pentax	305, 304
Philco	308, 309
Philips	308, 309, 310
Pioneer	308
Quasar	308, 309, 306
RCA/PROSCAN	304, 305, 308, 309, 311, 312, 313, 310, 329
Realistic	309, 330, 328, 335, 324, 338
Sansui	314
Samsung	322, 313, 321

Manufacturer	Code
Sanyo	330, 335
Scott	312, 313, 321, 335, 323, 324, 325, 326
Sharp	327, 328
Signature 2000 (M. Ward)	338, 327
SV 2000	338
Sylvania	308, 309, 338, 310
Symphonic	338
Tashiro	332
Tatung	314, 336, 337
Teac	314, 336, 338, 337
Technics	309, 308
Toshiba	312, 311
Wards	327, 328, 335, 331, 332
Yamaha	314, 330, 336, 337
Zenith	331

### Cable Boxes

Manufacturer	Code
Sony	230
Hamlin/Regal	222, 223, 224, 225, 226
Jerrold/G.I.	201, 202, 203, 204, 205, 206, 207, 208, 218, 222
Oak	227, 228, 229
Panasonic	219, 220, 221
Pioneer	214, 215
Scientific Atlanta	209, 210, 211
Tocom	216, 217
Zenith	212, 213

### Satellite Receivers

Manufacturer	Code
Sony	801
Dish Network	810
Echostar	810
General Electric	802
Hitachi	805
Hughes	804
Mitsubishi	809
Panasonic	803
RCA/PROSCAN	802, 808
Toshiba	806, 807

\* If an Aiwa VCR does not work even though you enter the code for Aiwa, enter the code for Sony instead.

## Using your Remote Controls with Other Equipment

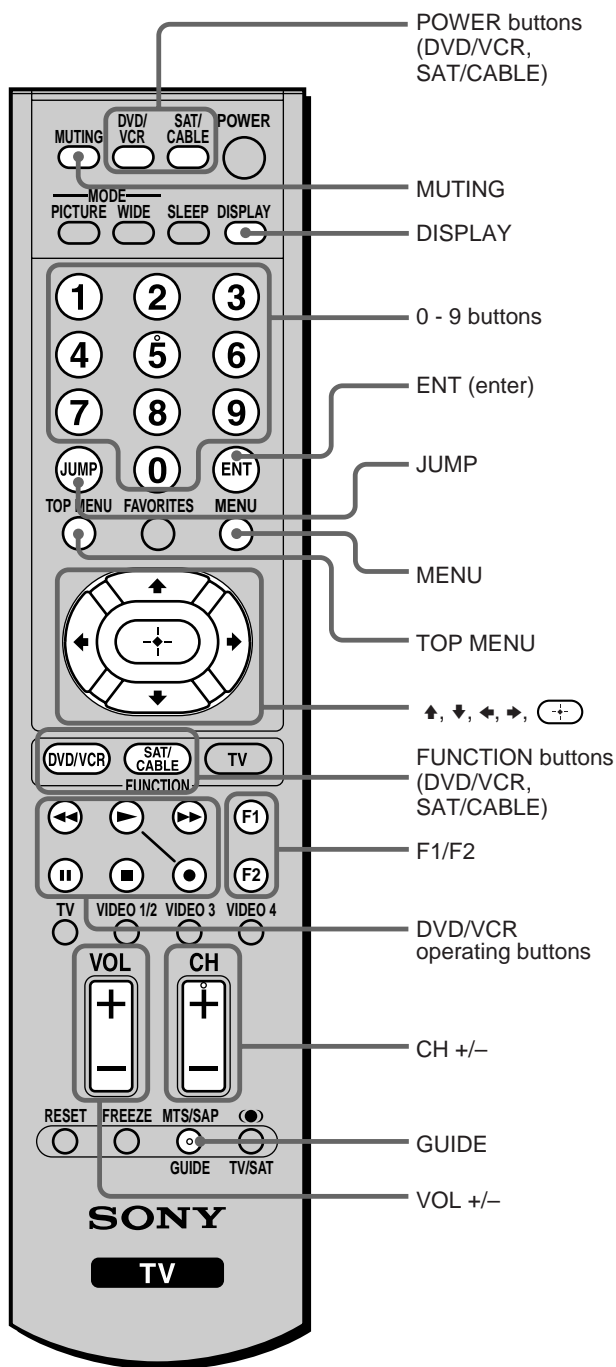

## Operating a Cable Box

To	Press
Turn on/off	SAT/CABLE (POWER)
Control a cable box	SAT/CABLE (FUNCTION)
Select a channel	0 - 9 buttons, ENT (enter)
Change channels	CH +/-
Go to the previous channel	JUMP

## Operating a Satellite Receiver

To	Press
Turn on/off	SAT/CABLE (POWER)
Control a satellite receiver	SAT/CABLE (FUNCTION)
Select a channel	0 - 9 buttons, ENT (enter)
Change channels	CH +/-
Go to the previous channel	JUMP
Display the channel number	DISPLAY
Display the DBS guide	GUIDE
Display the DBS menu	MENU
Move the highlight (cursor)	↑, ↓, ←, →
Select the item	⊕

## Operating a VCR

To	Press
Turn on/off	DVD/VCR (POWER)
Control a VCR	DVD/VCR (FUNCTION)
Change channels	CH +/-
Record	▶ and ● simultaneously
Play	▶
Stop	■
Fast forward	▶▶
Rewind	◀◀
Pause	⏸ (press again to resume normal playback)
Search the picture forward or backward	▶▶ or ◀◀ during playback (release to resume normal playback)

## Operating a DVD Player or DVD Changer

To	Press
Turn on/off	DVD/VCR (POWER)
Control a DVD player	DVD/VCR (FUNCTION)
If you have a DVD changer, to skip discs	F1
Play	▶
Stop	■
Pause	(press again to resume normal playback)
Step through different tracks of an audio disc	▶▶ to step forward or ◀◀ to step backward
Step through different chapters of a DVD disc	CH + to step forward or CH - to step backward
Select a track directly	0 - 9 buttons
Display the menu (Setup)	MENU
Display the top menu	TOP MENU
Operate the DVD menu	↑, ↓, ←, →, (◂)

## Operating a 5.1ch DVD AV System (Sony DAV)

To	Press
Turn on/off	DVD/VCR (POWER)
Select other equipment connected to the DAV	F1
Skip a disk	F2
Display the DVD menu	TOP MENU
Display the menu (Setup)	MENU
Move the highlight (Cursor)	↑, ↓, ←, →
Select the item	(◂)
Change the volume	VOL +/-, MUTING

## Operating a DVD/VCR or DVD/HDD Combo Unit

To	Press
Turn on/off	DVD/VCR (POWER)
If you have a DVD/VCR combo component, Select the DVD	F1
Select the VCR	F2
If you have a DVD/HDD combo component, Select the DVD	F1
Select the HDD	F2
Record	● and ▶ simultaneously (VCR)
Play	▶ (VCR)
Stop	■ (VCR)
Fast forward	▶▶ (VCR)
Rewind the tape	◀◀ (VCR)
Pause	(VCR)
Search the picture forward or backward	▶▶ or ◀◀ during playback (release to resume normal playback) (VCR)
Display the DVD menu	TOP MENU
Play	▶ (DVD)
Stop	■ (DVD)
Pause	(DVD)
Step through different tracks of the disc	▶▶ to step forward or ◀◀ to step backward (DVD)
Step through different chapters of a DVD disc	CH + to step forward or CH - to step backward (DVD)

## Operating an AV Receiver

To	Press
Turn on/off	DVD/VCR (POWER)
Change the volume	VOL +/-, MUTING

# Overview of the TV Controls and Connectors

## Front Panel Controls and Connectors

To open the control door

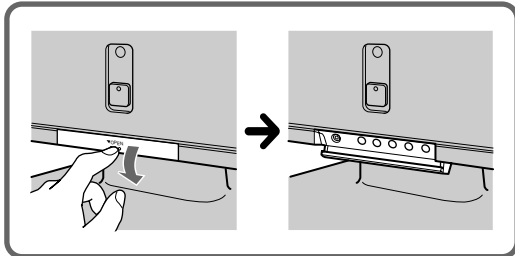

To open the control door of your TV, push the door just under the “▼ OPEN” mark.

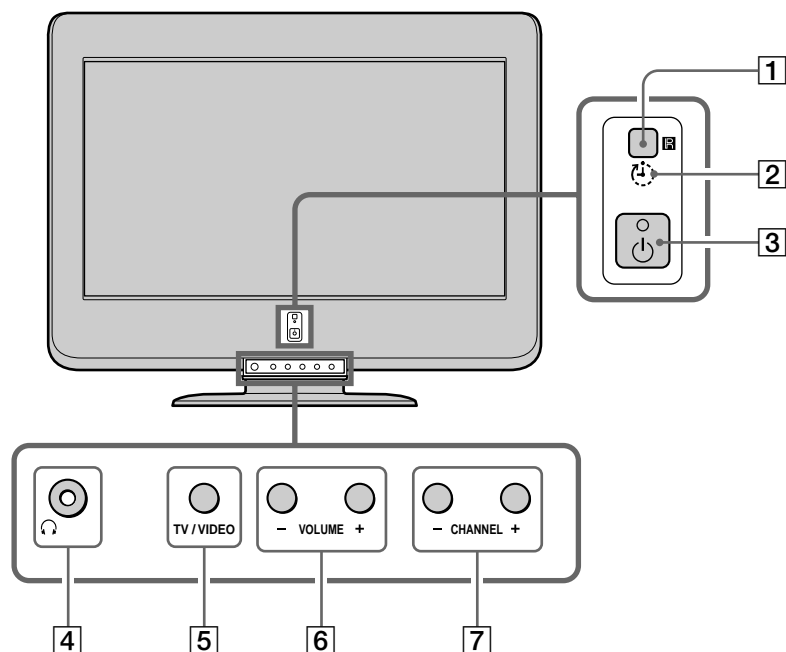

Item/Jack	Description
1 (IR) Infrared Receiver	Receives IR signals from the remote control.
2 (Timer) LED	When lit, indicates one of the timers is set. When the timer is set, this LED will remain lit. For details, see page 72.
3 (Power) and (Power on/Stand by) LED	Press (Power) to turn on and off the TV. The LED lights up green when the TV is turned on. When in standby mode, the LED lights up in red. If the LED blinks continuously, this may indicate the TV needs servicing (see page 73).
4 (Headphones) jack	Connects to your headphones. If your headphones do not match the jack, use a suitable plug adaptor (not supplied).
5 TV/VIDEO	Press repeatedly to cycle through the video equipment connected to the TV's video inputs.
6 - VOLUME +	Press to adjust the volume.
7 - CHANNEL +	Press to scan through channels. To scan quickly through channels, press and hold down either CHANNEL - or +.



## Rear Panel Connectors

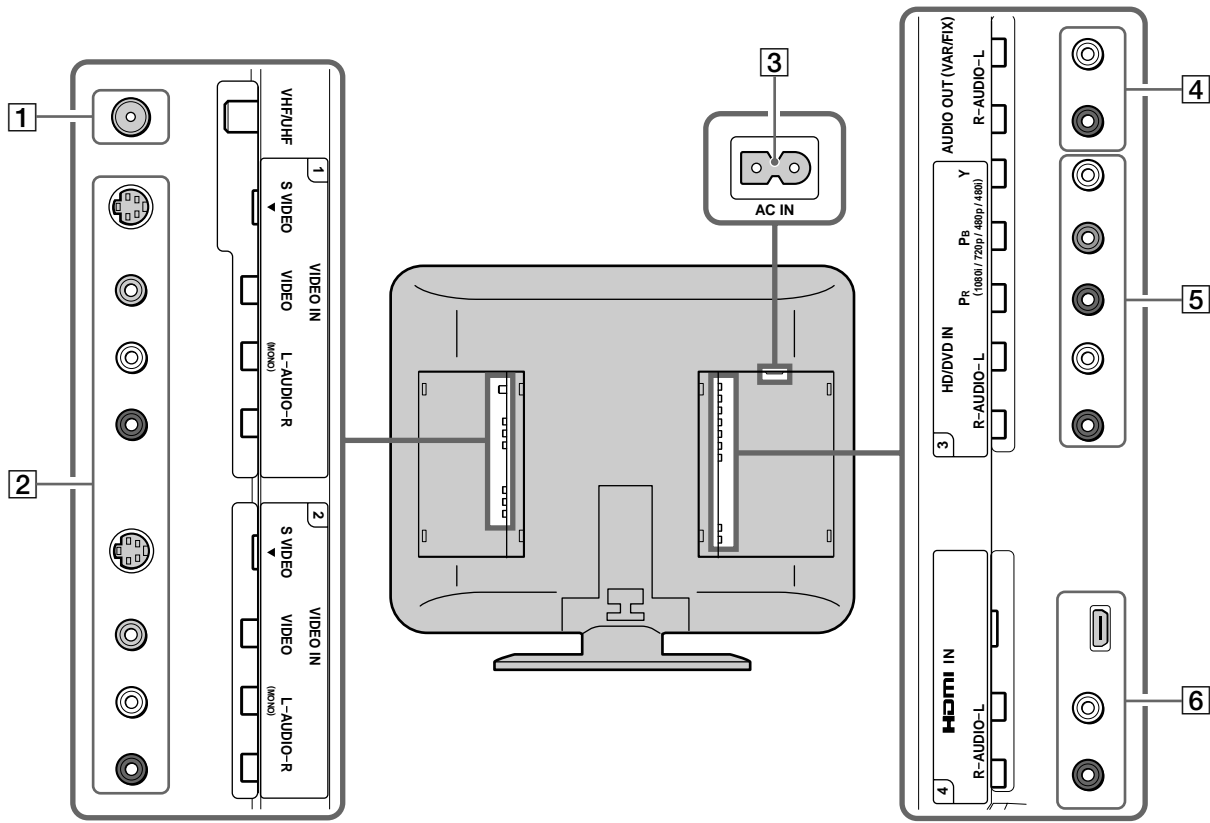

Jack	Description
<b>1</b> VHF/UHF	RF input that connects to your VHF/UHF antenna or cable box.
<b>2</b> VIDEO 1/2 IN VIDEO/L-AUDIO-R	Connect to the composite A/V output jacks on your VCR or other video component. This video connection provides better picture quality than the VHF/UHF ( <b>1</b> ) connections.  When your VCR or other equipment has S VIDEO S VIDEO                      Connect to the S VIDEO OUT jack of your VCR or other video equipment. S VIDEO provides better picture quality than either composite video or VHF/UHF ( <b>1</b> ) connections.
<b>3</b> AC IN	Connects the supplied AC power cord.
<b>4</b> AUDIO OUT (VAR/FIX) L/R	Connects to the left and right audio input jacks of your audio or video equipment. You can use these outputs to listen to your TV's audio through your stereo system.
<b>5</b> HD/DVD 3 IN Y, Pb, Pr/L-AUDIO-R	Connect to your DVD player's or digital satellite receiver's or digital cable box's component video (Y, Pb, Pr) and audio (L/R) jacks. Component video provides better picture quality than the S VIDEO ( <b>2</b> ), the VHF/UHF ( <b>1</b> ) or the composite video ( <b>2</b> ) connections.
<b>6</b> HDMI 4 IN HDMI/L-AUDIO-R	HDMI (High-Definition Multimedia Interface) provides an uncompressed, all-digital audio/video interface between this TV and any HDMI-equipped audio/video component, such as a digital satellite receiver, digital cable box, DVD player, and AV receiver. HDMI supports enhanced, or high-definition video, plus stereo digital audio.

## Attaching and Removing the Cable Cover

### Removing the cable cover

- 1 Push the hooks and draw the cable cover towards you.

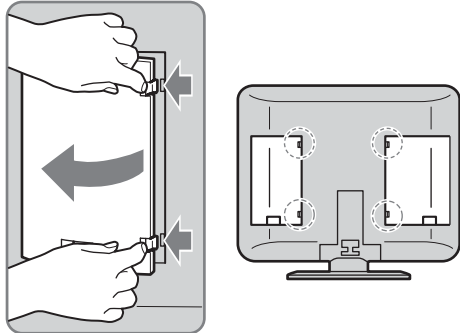

- 2 Detach the cable cover from the hooks on the side of the TV.

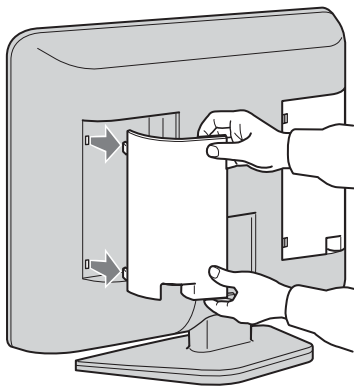

### Attaching the cable cover

- 1 Attach the cable cover to the hooks on the side of the TV.

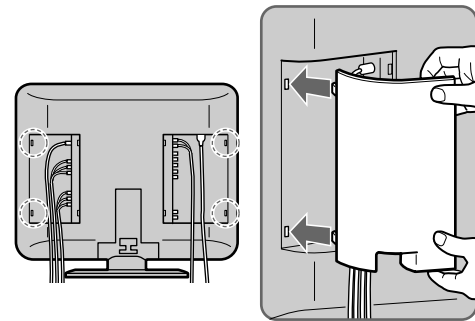

- 2 While pressing the hooks, push the cable cover onto the TV until it clicks.

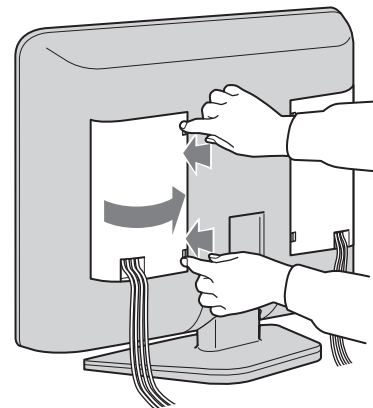

### Tip

Attach the cable cover to the TV after connecting the cables.

## Bundling Cords and Cables

You can organize the cables in the back of the TV.

- 1 Bundle the cables into the opening of the cable cover, and attach the cover.
- 2 Put the cables from both sides together and secure them with the clip at the bottom.

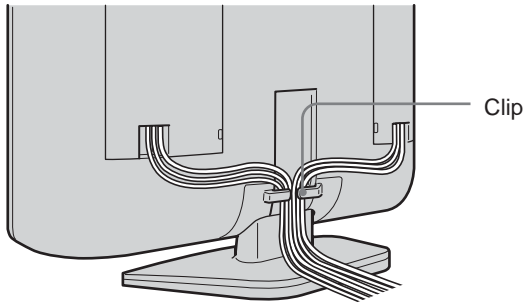

### Notes

- It may not be possible to fasten with clips if the cables are too thick.
- If all the cables cannot be secured with the clip, you may leave some of them hanging down on either side of the TV.

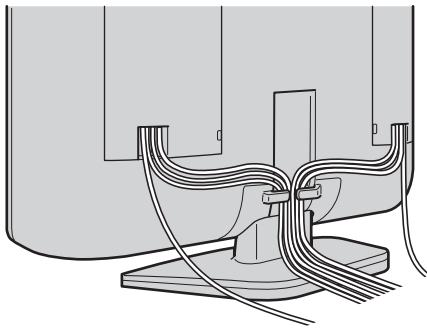

## Adjusting the Viewing Angle of the TV

You can adjust the angle to avoid the reflection of light and get a better view of the TV.

### Note

- When adjusting the angle, steady the base of the stand with your hand. Be careful not to get your fingers caught between the TV and the stand.
- When you adjust the angle, make sure that the cables are not caught between the TV and the stand. If some of the cables get caught, divide them into two groups at the clip and pull them away from each other to free them up.

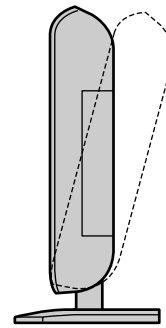
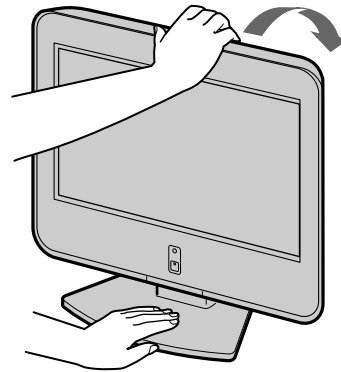

## Carrying the TV

When carrying the TV, hold it as illustrated below.

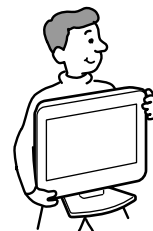

# Connecting and Setting the TV

## Basic Connections (Connecting Cable or an Antenna)

### Connector types

You may find it necessary to use some of the following connector types during set up.

#### Supplied 75-ohm coaxial cable

Screw-on type



#### S VIDEO cable

High quality video cable for enhanced picture quality



#### AUDIO/VIDEO cable



VIDEO - Yellow  
AUDIO (Left) - White  
AUDIO (Right) - Red

Some DVD players are equipped with the following three video connectors:

Y - Green  
P<sub>B</sub> (C<sub>B</sub>, C<sub>b</sub> or B-Y) - Blue  
P<sub>R</sub> (C<sub>R</sub>, C<sub>r</sub> or R-Y) - Red



#### HDMI cable

High definition multimedia interface cable



## Connecting directly to cable or an antenna

### VHF only or VHF/UHF or cable

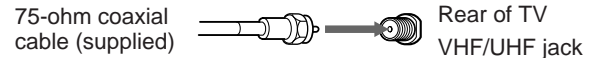

Also, set “Cable” to “Off” in the  (Channel) menu (see page 37).

### Notes

- It is strongly recommended to connect the antenna using a 75-ohm coaxial cable to get optimum picture quality. A 300-ohm twin lead cable can be easily affected by radio noise and the like, resulting in signal deterioration. If you use a 300-ohm twin lead cable, keep it away as far as possible from the TV.
- Do not detach the ferrite core from the supplied 75-ohm coaxial cable.
- The ferrite core is attached to one end of (not the center of) the supplied 75-ohm coaxial cable. When connecting the cable to the TV, insert the end with the ferrite core into the VHF/UHF jack.

## Cable box connections

Use this hookup if:

- You subscribe to a cable TV system that uses scrambled or encoded signals requiring a cable box to view all channels, and
- You do not intend to hook up any other audio or video equipment to your TV.

- 1 Connect the coaxial connector from your cable service to the cable box's IN jack.
- 2 Using the supplied 75-ohm coaxial cable, connect the cable box's OUT jack to the TV's VHF/UHF jack.

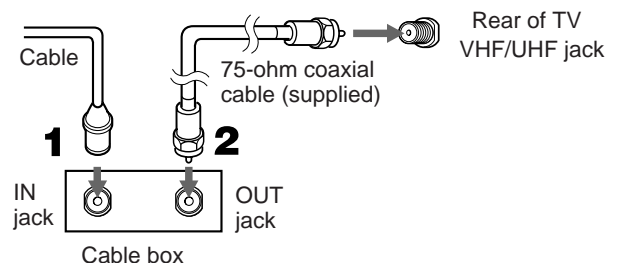

### Tips

- The supplied remote control can be programmed to operate your cable box (see “Programming the Remote Control” on page 16).
- To change channels using the cable box, set your TV to channel 3 or 4 depending on the cable box channel output.
- If you will be controlling all channel selection through your cable box, consider using the Channel Fix feature to set your TV to channel 3 or 4 (see page 38).

## Connecting Optional Equipment

Use the instructions in this section to connect the following optional equipment:

If you are connecting	See page
VCR and Cable TV	26 page
Satellite Receiver	27 page
Satellite Receiver and VCR	28 page
AV Receiver	29 page
DVD Player with Component Video Connectors	30 page
DVD Player with S Video and Audio Connectors	31 page
Digital Cable Box	32 page
Digital Satellite Receiver	33 page
Digital Satellite Receiver with HDMI Connector	34 page

## Connecting the Power Cord

Complete other connections prior to connecting the power cord.

- 1** Connect the power cord to the AC IN connector of the TV.
- 2** Connect the other plug of the power cord to a wall outlet.

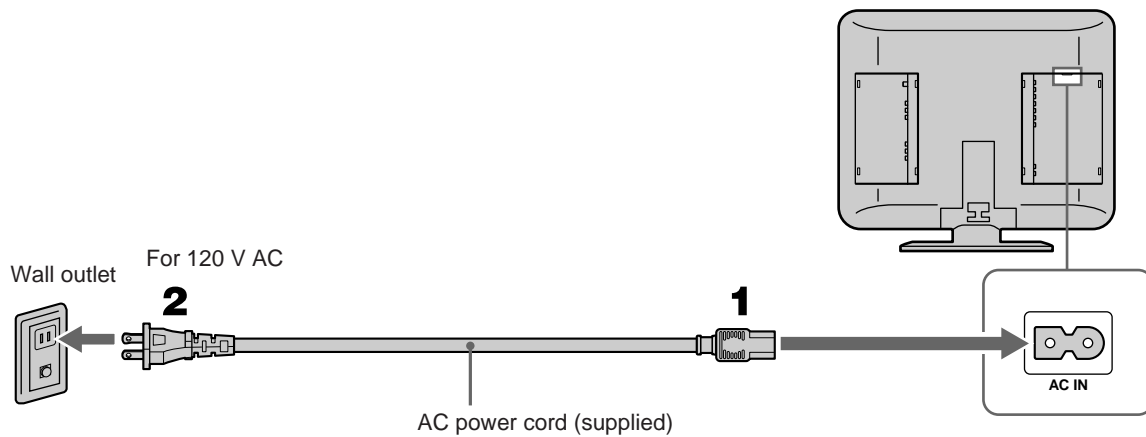

# Connecting a VCR and Cable TV

Use this hookup if:

- You subscribe to a cable TV system that does not require a cable box.

**Disconnect all power sources before making any connections.**

- 1** Connect the CATV cable to the VCR's IN jack.
- 2** Using the supplied 75-ohm coaxial cable, connect the VCR's OUT jack to the TV's VHF/UHF jack.
- 3** Using A/V and S VIDEO cables, connect the VCR's AUDIO and S VIDEO OUT jacks to the TV's AUDIO and S VIDEO IN jacks (VIDEO 1 IN or VIDEO 2 IN).

### Tip

If your VCR is not equipped with S VIDEO, use a VIDEO cable (yellow) instead of the S VIDEO cable.

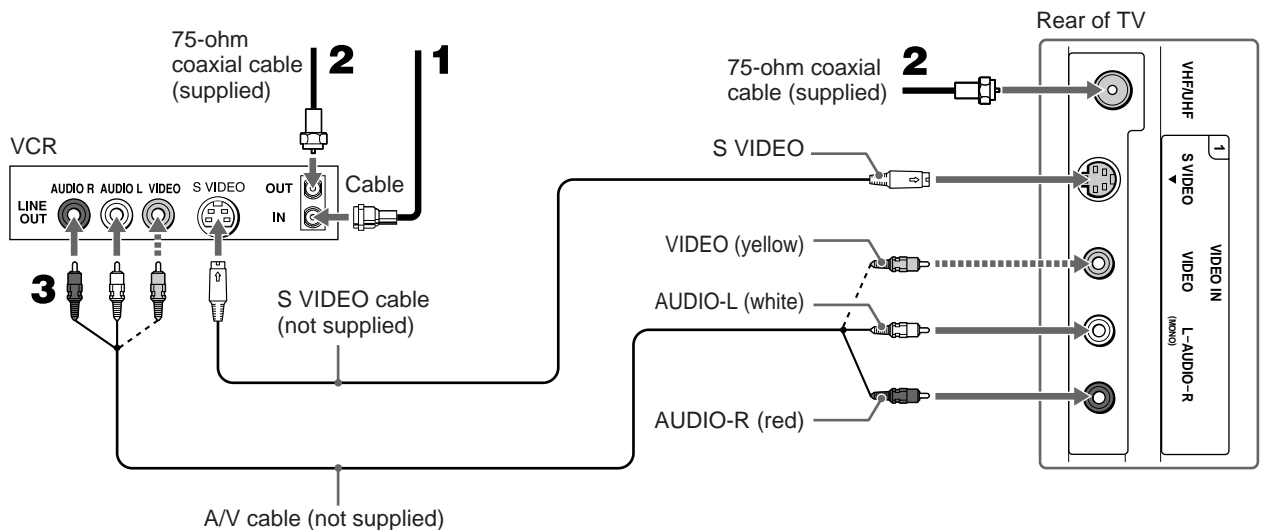









### Note

When you connect video equipment to both the VIDEO and the S VIDEO input jacks, make sure "Auto YC" in the  (Setup) menu is set to "On" to view the S VIDEO input (see below).

### When connecting both VIDEO IN and S VIDEO IN

Using the menu, you can select the jack from which the TV receives the input signal. You can set it for each video input (VIDEO 1 IN and VIDEO 2 IN) separately. The TV is factory set to receive S VIDEO input signals.

- 1** Press VIDEO 1/2 repeatedly until the desired video input appears.
- 2** Press MENU.
- 3** Press  to select  (Setup), then press .
- 4** Press  to select "Auto YC," then press .
- 5** To watch the pictures input from the S VIDEO input jack: Press  to select "On," then press .  
To watch the pictures input from the VIDEO input jack: Press  to select "Off," then press .
- 6** Press MENU to exit the menu screen.



# Connecting a Satellite Receiver

**Disconnect all power sources before making any connections.**

- 1** Connect the satellite antenna cable to the satellite receiver's SATELLITE IN jack.
- 2** Using A/V and S VIDEO cables, connect the satellite receiver's AUDIO and S VIDEO OUT jacks to the TV's AUDIO and S VIDEO IN jacks (VIDEO 1 IN or VIDEO 2 IN).

**Tip**

If your satellite receiver is not equipped with S VIDEO, use a VIDEO cable (yellow) instead of the S VIDEO cable.

- 3** Connect the supplied 75-ohm coaxial cable from your cable box or antenna to the TV's VHF/UHF jack.

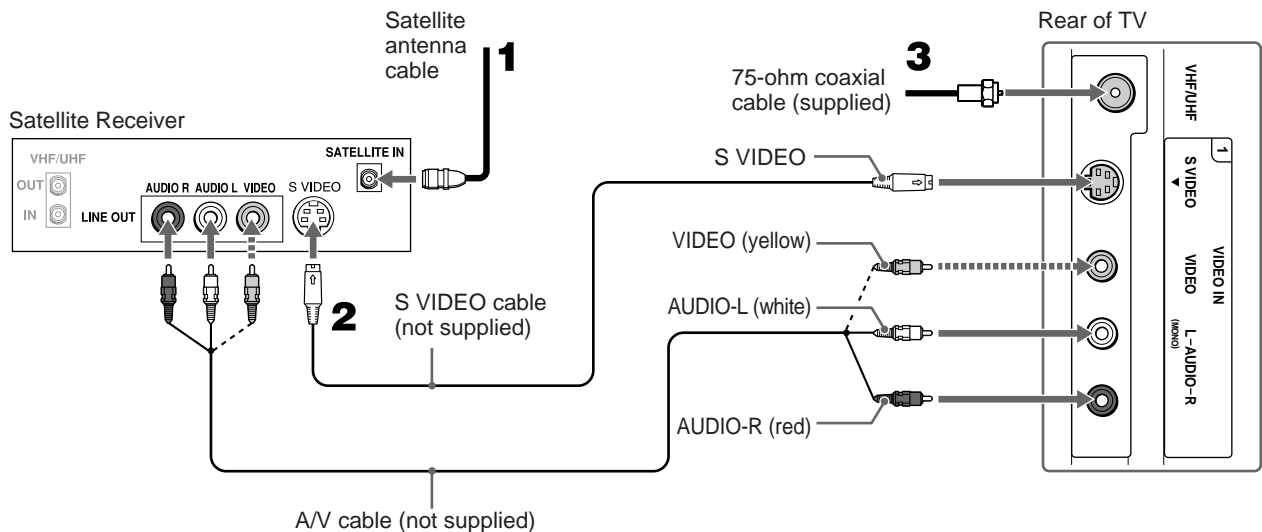

**Note**

When you connect video equipment to both the VIDEO and the S VIDEO input jacks, make sure "Auto YC" in the  (Setup) menu is set to "On" to view the S VIDEO input (see page 26).

**Tip**

Use VIDEO 1/2 on the remote control to select VIDEO 1 IN (or VIDEO 2 IN if you use the VIDEO 2 IN jacks for this hookup) to watch satellite TV.

# Connecting a Satellite Receiver and a VCR

Disconnect all power sources before making any connections.

- 1 Connect the satellite antenna cable to the satellite receiver's SATELLITE IN jack.
- 2 Connect the CATV cable to the VCR's VHF/UHF IN jack.
- 3 Using the supplied 75-ohm coaxial cable, connect the VCR's OUT jack to the TV's VHF/UHF jack.
- 4 Using A/V and S VIDEO cables, connect the satellite receiver's AUDIO and S VIDEO OUT jacks to the VCR's AUDIO and S VIDEO IN jacks.

## Tip

If your VCR or satellite receiver is not equipped with S VIDEO, use a VIDEO cable (yellow) instead of the S VIDEO cable.

- 5 Using A/V and S VIDEO cables, connect the VCR's AUDIO and S VIDEO OUT jacks to the TV's AUDIO and S VIDEO IN jacks (VIDEO 1 IN or VIDEO 2 IN).

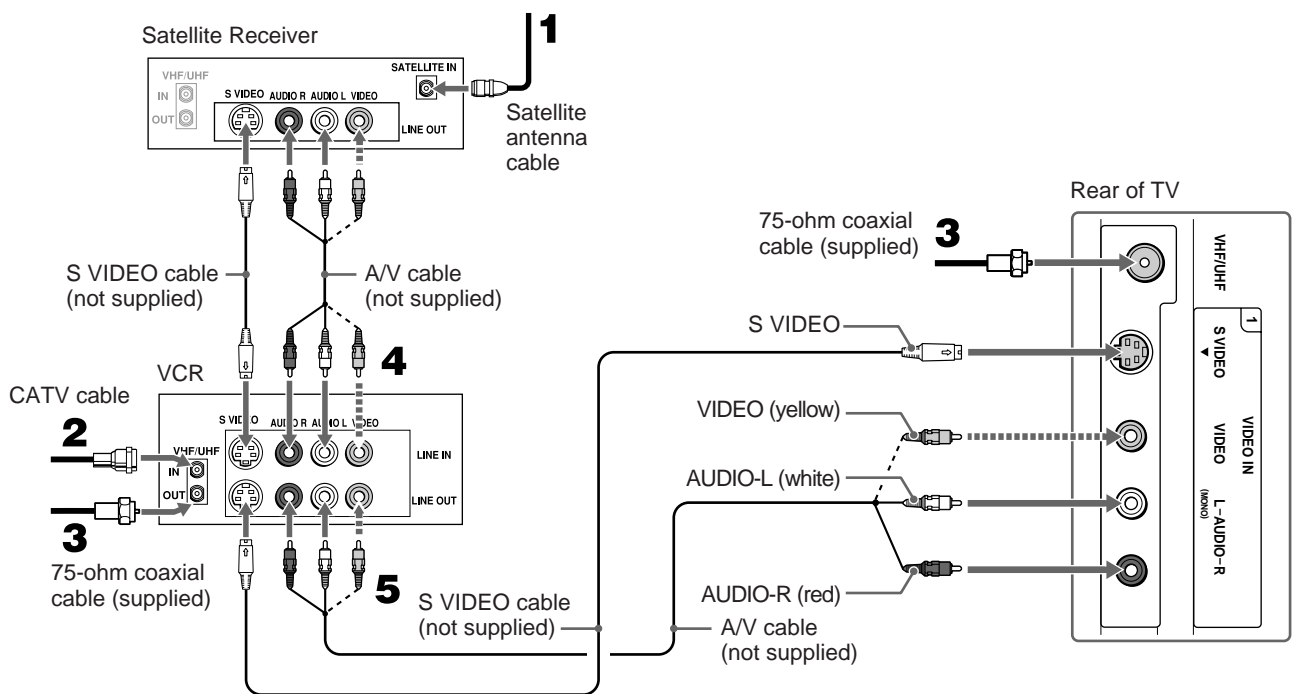

## Note

When you connect video equipment to both the VIDEO and the S VIDEO input jacks, make sure "Auto YC" in the  (Setup) menu is set to "On" to view the S VIDEO input (see page 26).

## Tips

- Be sure your VCR's video input is set correctly. Consult your VCR's operating manual for instructions.
- Use VIDEO 1/2 on the remote control to select VIDEO 1 IN (or VIDEO 2 IN if you use the VIDEO 2 IN jacks for this hookup) to watch satellite TV or to watch a tape on the VCR (your VCR must be turned on).

# Connecting an AV Receiver

**Disconnect all power sources before making any connections.**

Using an AUDIO cable, connect the TV's AUDIO OUT jacks to the AV receiver's AUDIO IN jacks.

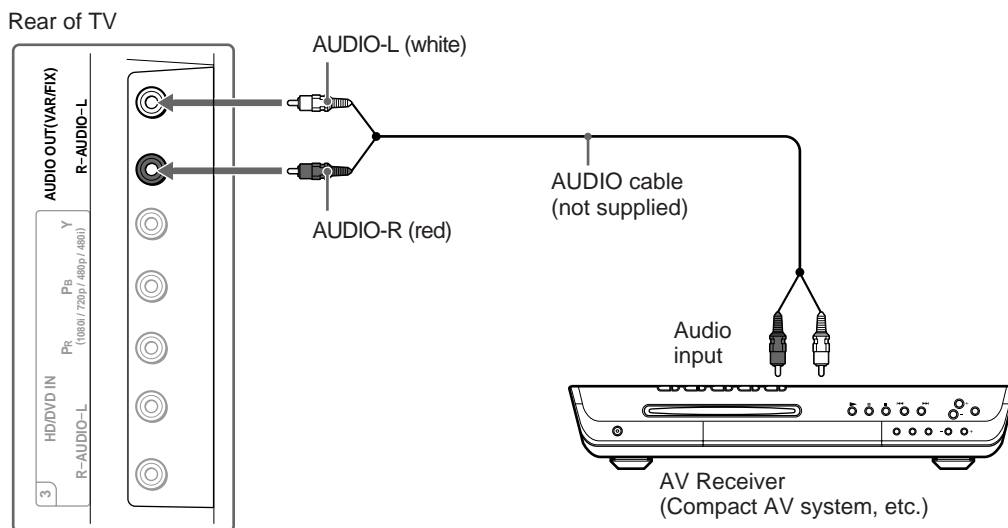

## When using your audio system speakers

You can control the volume output from your audio system using the TV's remote control (see "Programming the Remote Control" on page 16), by setting "Audio Out" in the  (Audio) menu to "Variable."

If you want to adjust the volume through your audio system, set "Audio Out" to "Fixed."

## Notes

- The video signal is not output through the AUDIO OUT jacks.
- When "Audio Out" in the  (Audio) menu is set to "Variable," "Speaker" is to "Off," check if the speaker volume is moderate before switching "Speaker" from "Off" to "On." Otherwise, the speaker volume may be too loud.

# Connecting a DVD Player with Component Video Connectors

Use this hookup if:

- Your DVD player has component (Y, P<sub>B</sub>, P<sub>R</sub>) jacks.

## Tips

- The Y, P<sub>B</sub> and P<sub>R</sub> jacks on your DVD player are sometimes labeled as Y, C<sub>B</sub> and C<sub>R</sub>, or Y, B-Y and R-Y. If so, connect the cables to the matching colors.
- To take advantage of the Wide Screen Modes, set the aspect ratio of the output signal to 16:9 on your DVD player. For details, refer to the operating instructions supplied with your DVD player.

**Disconnect all power sources before making any connections.**

- 1** Using a component video cable, connect the DVD player's Y, P<sub>B</sub> and P<sub>R</sub> jacks to the Y, P<sub>B</sub> and P<sub>R</sub> jacks on the TV.  
Use the HD/DVD 3 IN connections.
- 2** Using an AUDIO cable, connect the DVD player's AUDIO OUT jacks to the TV's AUDIO IN jacks.

## Note

The Y, P<sub>B</sub> and P<sub>R</sub> jacks do not provide audio, so audio cables must be connected to provide sound.

## Tip

Use VIDEO 3 on the remote control to select HD/DVD 3 IN to watch the DVD player input.

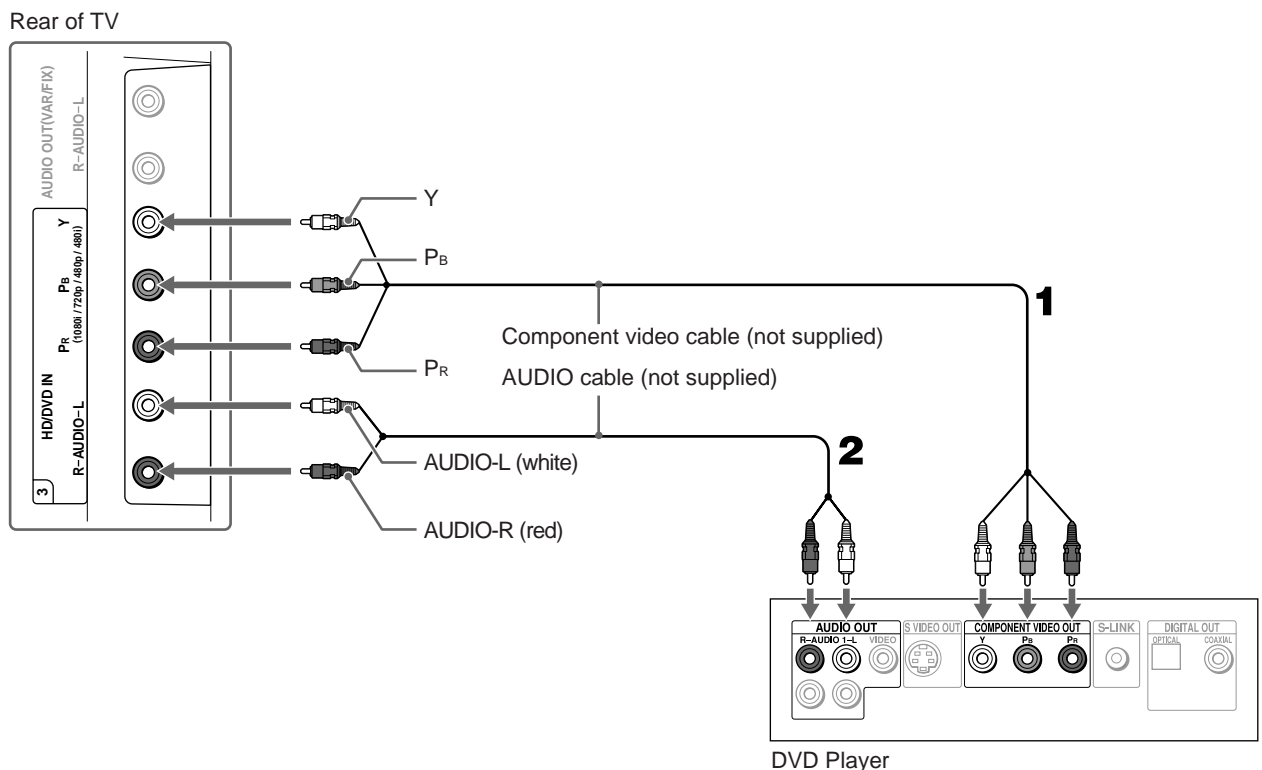

# Connecting a DVD Player with S Video and Audio Connectors

Use this hookup if:

- Your DVD player does not have component (Y, P<sub>B</sub>, P<sub>R</sub>) jacks.

## Tips

- If your DVD player has component video output connectors, for best picture quality, use the connection described on page 30.
- The Y, P<sub>B</sub> and P<sub>R</sub> jacks on your DVD player are sometimes labeled as Y, C<sub>B</sub> and C<sub>R</sub>, or Y, B-Y and R-Y. If so, connect the cables to the matching colors.
- To take advantage of the Wide Screen Modes, set the aspect ratio of the output signal to 16:9 on your DVD player. For details, refer to the operating instructions supplied with your DVD player.

**Disconnect all power sources before making any connections.**

- 1** Using an A/V cable, connect the DVD player's AUDIO OUT jacks to the TV's AUDIO IN jacks.
- 2** Using an S VIDEO cable, connect the DVD player's S VIDEO OUT jack to the TV's S VIDEO IN jack (VIDEO 1 IN or VIDEO 2 IN).

## Tip

If your DVD player is not equipped with S VIDEO, use a VIDEO cable (yellow) instead of the S VIDEO cable.

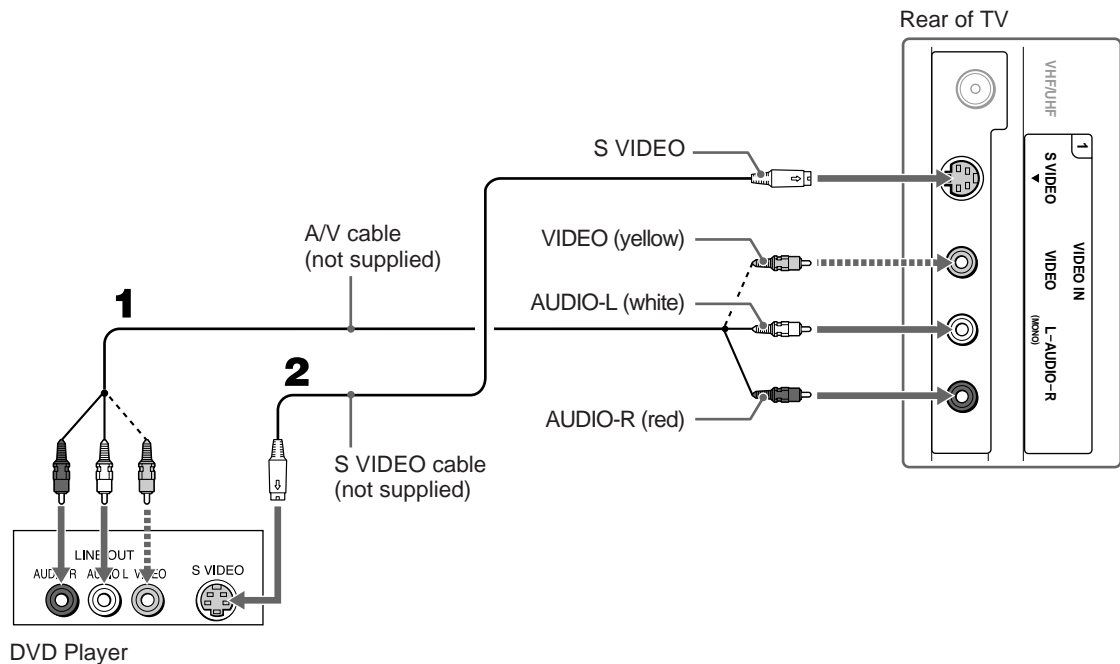

## Note

When you connect video equipment to both the VIDEO and the S VIDEO input jacks, make sure "Auto YC" in the  (Setup) menu is set to "On" to view the S VIDEO input (see page 26).

## Tip

Use VIDEO 1/2 on the remote control to switch to the DVD player input.

# Connecting a Digital Cable Box

**Disconnect all power sources before making any connections.**

- 1** Using a component video cable, connect the Digital Cable Box's Y, P<sub>B</sub> and P<sub>R</sub> jacks to the Y, P<sub>B</sub> and P<sub>R</sub> jacks on the TV. Use the HD/DVD 3 IN connections.

**Note**

Component video (Y, P<sub>B</sub>, P<sub>R</sub>) connection is necessary to view 480p, 720p, and 1080i formats. Note that this TV displays all format types of picture in a resolution of 1,366 dots × 768 lines.

- 2** Using an AUDIO cable, connect the Digital Cable Box's AUDIO OUT jacks to the TV's AUDIO IN jacks.

**Note**

The Y, P<sub>B</sub> and P<sub>R</sub> jacks do not provide audio, so audio cables must be connected to provide sound.

**Tip**

Use VIDEO 3 on the remote control to select HD/DVD 3 IN to watch the digital cable box input.

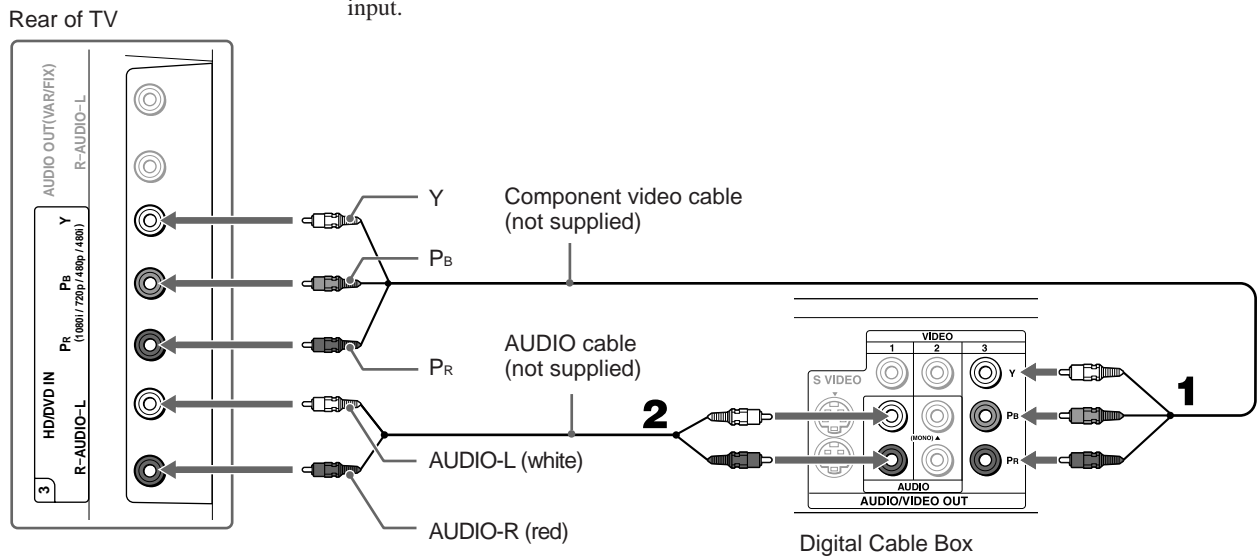

# Connecting a Digital Satellite Receiver

Disconnect all power sources before making any connections.

- Using a component video cable, connect the Digital Satellite Receiver's Y, P<sub>B</sub> and P<sub>R</sub> jacks to the Y, P<sub>B</sub> and P<sub>R</sub> jacks on the TV. Use the HD/DVD 3 IN connections.

### Note

Component video (Y, P<sub>B</sub>, P<sub>R</sub>) connection is necessary to view 480p, 720p, and 1080i formats. Note that this TV displays all format types of picture in a resolution of 1,366 dots × 768 lines.

- Using an AUDIO cable, connect the Digital Satellite Receiver's AUDIO OUT jacks to the TV's AUDIO IN jacks.

### Note

The Y, P<sub>B</sub> and P<sub>R</sub> jacks do not provide audio, so audio cables must be connected to provide sound.

### Tip

Use VIDEO 3 on the remote control to select HD/DVD 3 IN to watch the digital satellite receiver input.

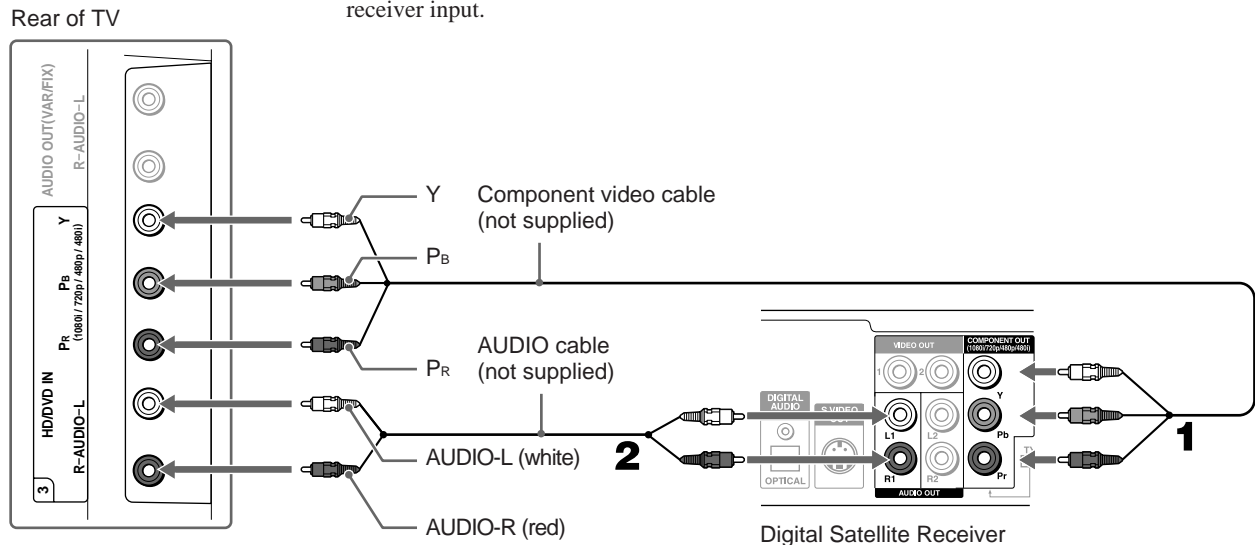

# Connecting a Digital Satellite Receiver with HDMI Connector

Use this hookup if:

- Your Digital Satellite Receiver has a High-Definition Multimedia Interface (HDMI).

**Disconnect all power sources before making any connections.**

Using an HDMI cable (not supplied), connect the Digital Satellite Receiver's HDMI OUT connector to the TV's HDMI IN connector.

Use the HDMI 4 IN connection.

## Tips

- The HDMI connector provides both video and audio signals, so it is not necessary to connect the audio cable.
- Use VIDEO 4 on the remote control to select HDMI 4 IN to watch the digital satellite receiver input.

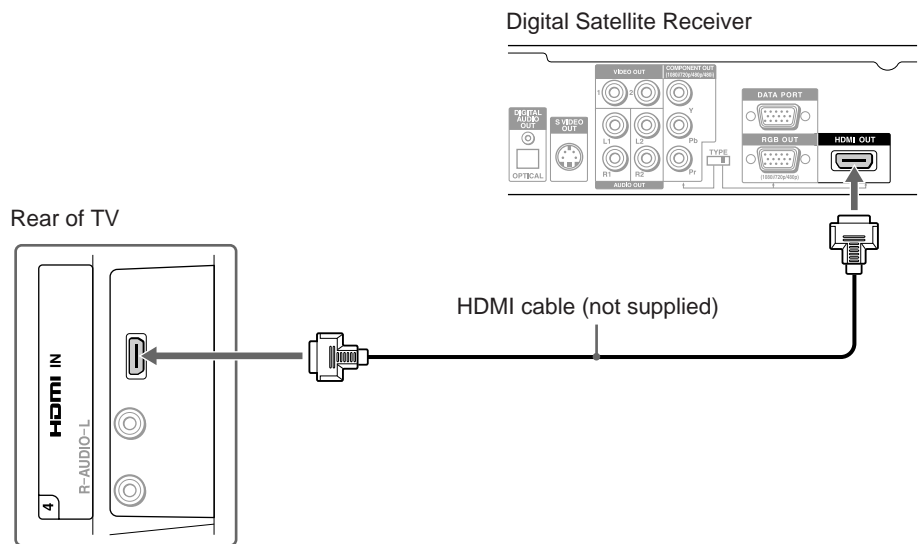



## When connecting to a Digital Satellite Receiver's DVI-HDTV connector

If the Digital Satellite Receiver does not have an HDMI connector, you can connect the TV's HDMI IN connector to the Digital Satellite Receiver's DVI-HDTV OUT connector using the HDMI cable (not supplied).

- 1 Using a HDMI to DVI-HDTV adapter or cable (not supplied), connect the Digital Satellite Receiver's DVI-HDTV OUT connector to the TV's HDMI IN connector.

Use the HDMI 4 IN connection.

### Note

The DVI-HDTV VIDEO connector does not provide audio, so audio cables must be connected to provide sound when an HDMI to DVI-HDTV adapter is used.

- 2 Using an AUDIO cable, connect the Digital Satellite Receiver's AUDIO OUT jacks to the TV's AUDIO IN jacks.

### Tip

Use VIDEO 4 on the remote control to select HDMI 4 IN to watch the digital satellite receiver input.

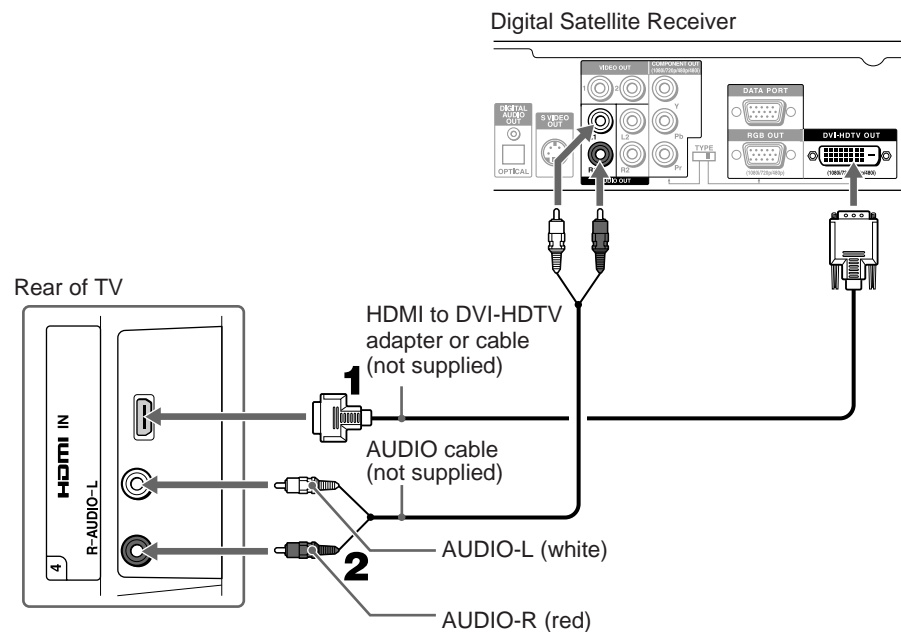

# Setting the TV

## Setting the Channels

After you finish connecting your TV, you can run Auto Program to set up your channels. The Auto Setup menu appears when you turn your TV on for the first time after installing it. To skip channels, see page 37.

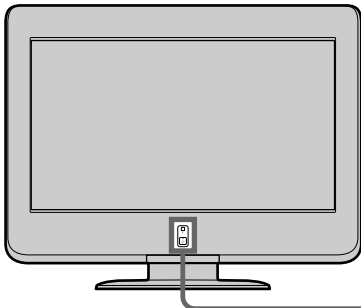

1

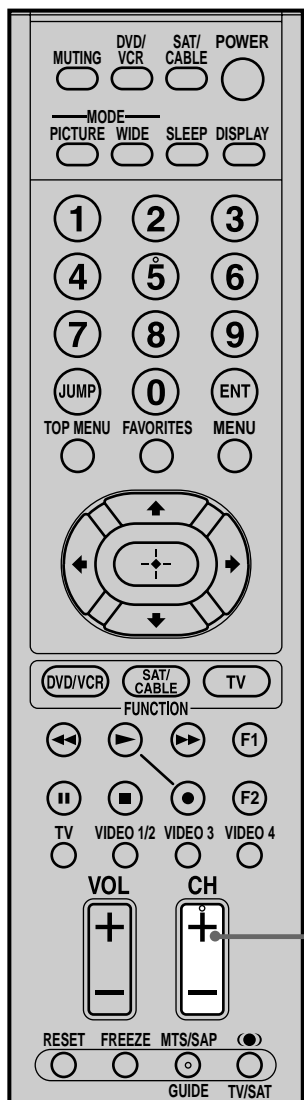

2

- 1 Press  (Power) on the TV.

The Auto Setup menu automatically appears on the screen when you turn on the TV for the first time.

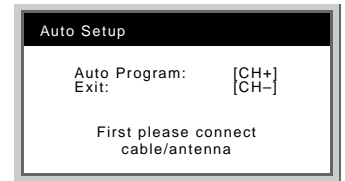
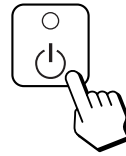







- 2 Press CH + on the remote control or on the control panel of your TV to perform Auto Program.

When all the receivable channels are stored, the “Channel Skip/Add” menu appears.

Auto Program is set to scan cable TV channels by default. To watch VHF/UHF channels with an antenna, see “To watch VHF/UHF channels with an antenna” on page 37.

### To perform Auto Program again

- 1 Press MENU.
- 2 Press  to select  (Channel), then press .
- 3 Press  to select “Auto Program,” then press .
- 4 Press .

“Auto Program” appears and the TV starts scanning and presetting channels automatically. When all the receivable channels are stored, the “Channel Skip/Add” menu appears. Using this menu, you can start skipping unnecessary channels (see “To skip channels” on page 37).

- 5 Press MENU to exit the menu screen.





### To cancel Auto Program

While “Auto Program” is displayed in step 3, press MENU on the remote control.

### Note

To watch cable TV channels, you have to subscribe to a cable TV company. Note that cable TV cannot be received in some areas. This TV receives cable TV channels 1-125. For details on cable TV subscription, consult your nearest cable TV company.

## To watch VHF/UHF channels with an antenna

- 1 Press MENU.
- 2 Press  $\uparrow/\downarrow$  to select  (Channel), then press .
- 3 Press  $\uparrow/\downarrow$  to select “Cable,” then press .
- 4 Press  $\uparrow/\downarrow$  to select “Off,” then press .
- 5 Perform steps 3 - 5 in “To perform Auto Program again” on page 36.

### Note



You cannot receive and set the cable TV channels and VHF/UHF channels at the same time.

### Tip

When you have a cable box or satellite receiver connected, the Channel Fix feature is useful. For details, see page 38.

## To skip channels

You can skip unnecessary channels when selecting channels using the CH +/- buttons.

- 1 Press MENU.
- 2 Press  $\uparrow/\downarrow$  to select  (Channel), then press .
- 3 Press  $\uparrow/\downarrow$  to select “Channel Skip/Add,” then press .

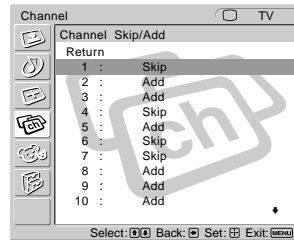

- 4 Press  $\uparrow/\downarrow$  to select the channel you want to skip, then press .

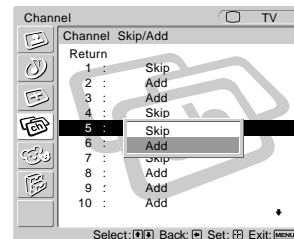

Example: Select this to skip channel 5.

### Tip

To scroll through the list, press and hold  $\uparrow/\downarrow$ .

- 5 Press  $\uparrow/\downarrow$  to select “Skip,” then press .

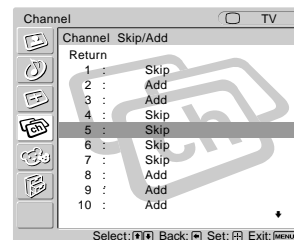



If you want to re-enter the skipped channel, select “Add.”

- 6 Press MENU to exit the menu screen.

(Continued)

## To fix in a TV channel

If you have connected a cable box or satellite receiver to your TV, and do not intend to connect any other audio or video equipment, it is recommended that you fix a TV channel. Doing so will ensure no accidental channel switch when using your TV.

- 1 Press MENU.
- 2 Press  $\uparrow/\downarrow$  to select  (Channel), then press .
- 3 Press  $\uparrow/\downarrow$  to select "Channel Fix," then press .

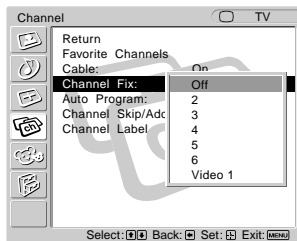

- 4 Press  $\uparrow/\downarrow$  to select the channel you want to set, then press .



Option	Description
2 - 6	Select one of these channels if you have connected the equipment to the VHF/UHF jack.
Video 1	Select this if you have connected the equipment to the VIDEO 1 IN jacks.
Off	Select this to turn off the Channel Fix feature.

- 5 Press MENU to exit the menu screen.

### Notes

- When you fix a TV channel, the Favorite Channel feature cannot be used.
- When you fix a TV channel, you cannot select "Channel Skip/Add" in the menu. To use it, set "Channel Fix" to "Off."

## Using the Menu

Most of advanced settings and adjustments are performed using the menu screen. Basic operations to navigate through menus are described below.

- Items which appear in yellow are selected.
- You cannot select items which appear in pale color.

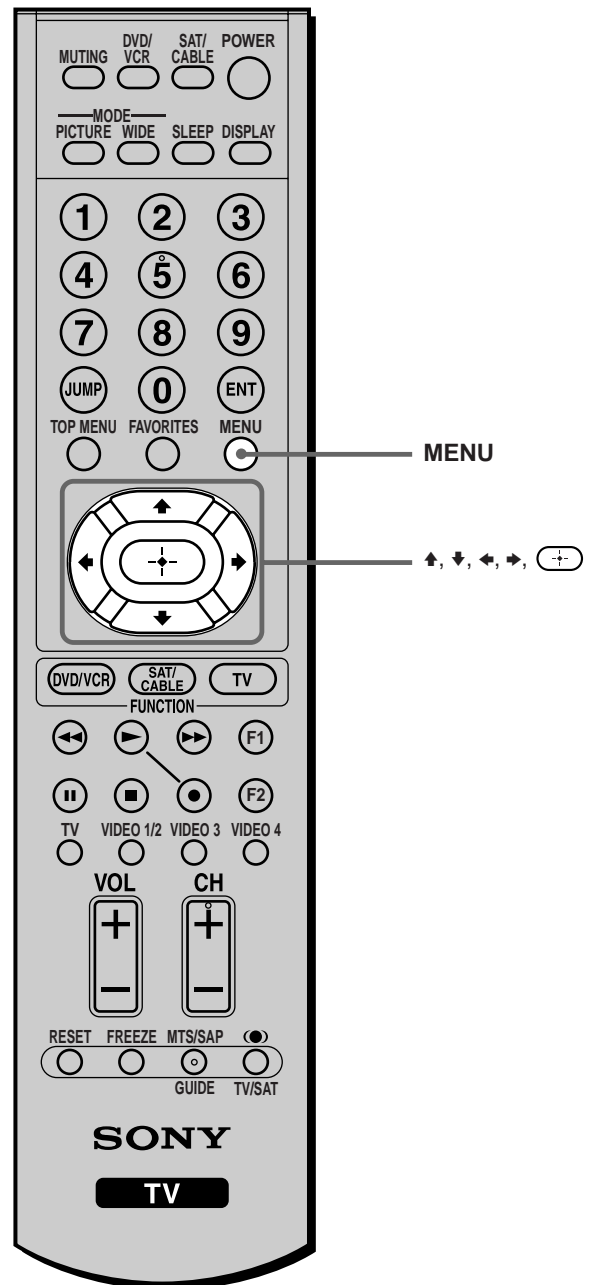

## To open the menu screen and select the option

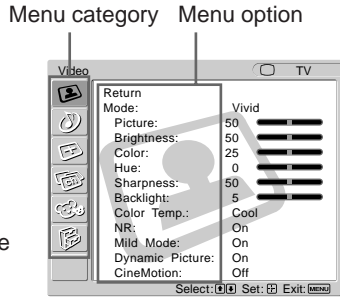

Press MENU to open the menu screen.

Press  $\uparrow/\downarrow$  to select the desired category, then press  $\rightarrow$ .

To exit the menu screen, press MENU again.

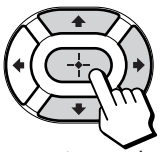

Press  $\uparrow/\downarrow$  to select the option, then press  $\rightarrow$  or  $\leftarrow$ .

(The  $\rightarrow$  button cannot be used on some menus.)

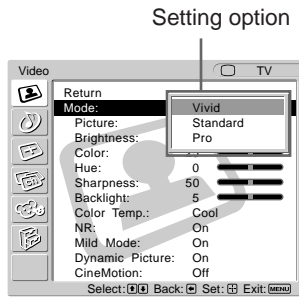

(Example: when selecting "Mode" in the (Video) menu)

## To adjust the setting

Maximize the setting value

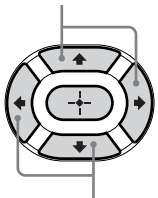

Minimize the setting value



(Example: when selecting "Picture" in the (Video) menu)

# Selecting the On-screen Menu Language

You can select the language to be displayed in all menus.

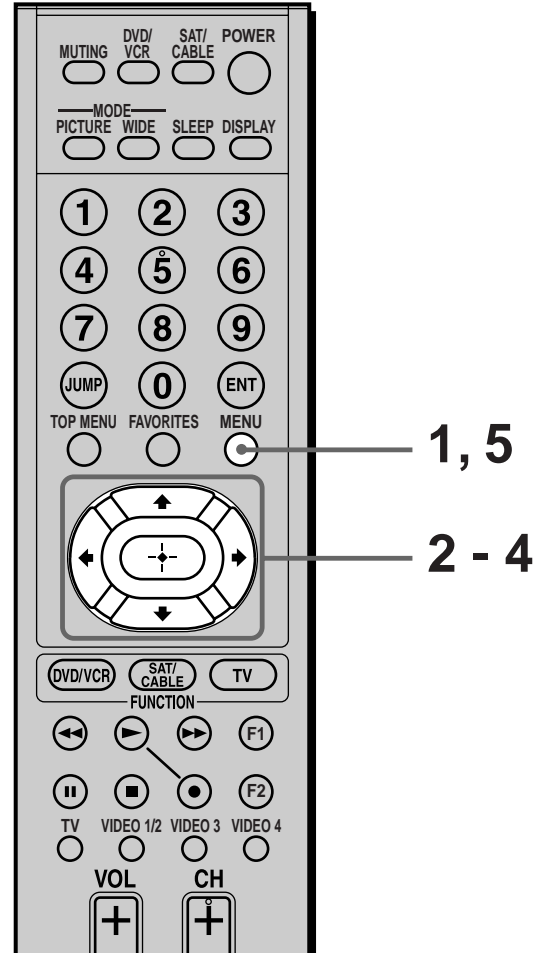

**1** Press MENU.

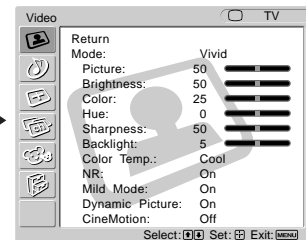

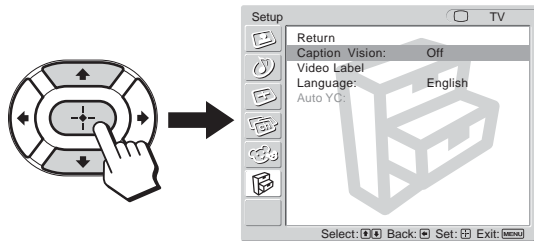

(Continued)

**2** Press  $\uparrow/\downarrow$  to select  (Setup), then press .

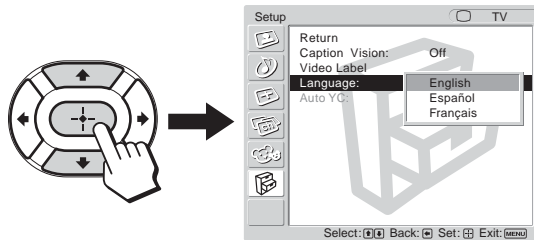

**3** Press  $\uparrow/\downarrow$  to select “Language,” then press .



**4** Press  $\uparrow/\downarrow$  to select your preferred language, then press .

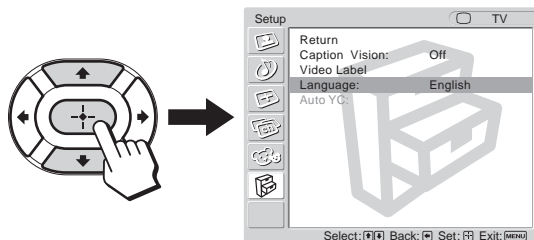

**5** Press MENU to exit the menu screen.

# Watching the TV

## Watching the TV

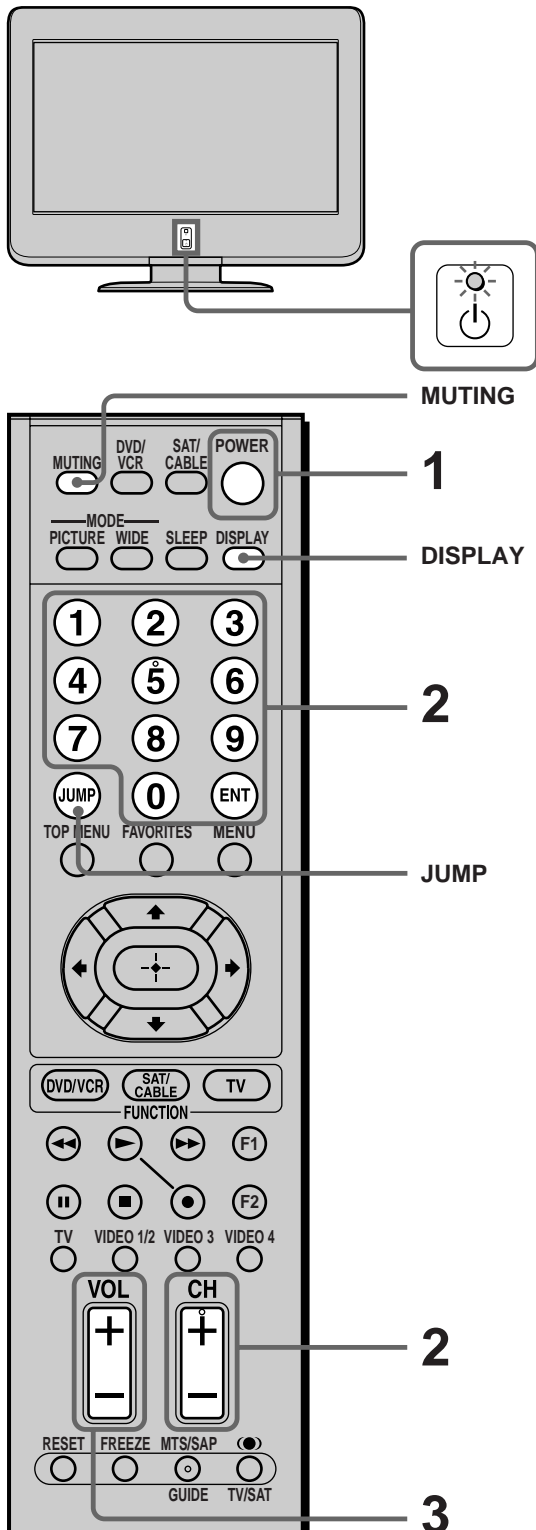



- 1 Press POWER on the remote control.

POWER



**Tip**

When the  (Power on/Stand by) LED is off, press the  (Power) button on the TV.

- 2 Select the desired channel using the 0 - 9 and ENT (enter) buttons.

Press 0 - 9 to select a channel. The channel changes after 2 seconds. Press ENT (enter) to select immediately.

Use the CH +/- buttons to scan through the channels.

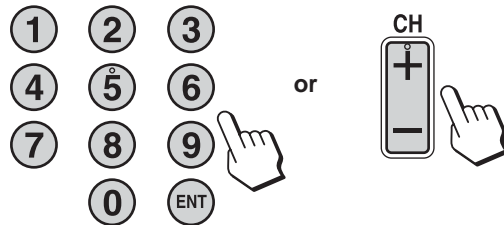

**Tip**

When you press and hold CH +/-, the channel number will change rapidly.

- 3 Adjust the volume using the VOL +/- buttons.



### Other button operations

Press	To
MUTING	Mute the sound. Press it again or press VOL + to restore sound.
DISPLAY	Press once to display the current channel number/channel label and the Wide Screen Mode, or the current video input number/video label and the Wide Screen Mode. When the display is turned on, the current channel number/channel label or video input number/video label remains displayed. Press it again to turn the display off.
JUMP	Jump back and forth between two channels. The TV alternates between the current channel and the last channel selected using the 0-9 buttons.

## Watching with closed caption

You can display Caption Vision if the broadcaster offers this service.

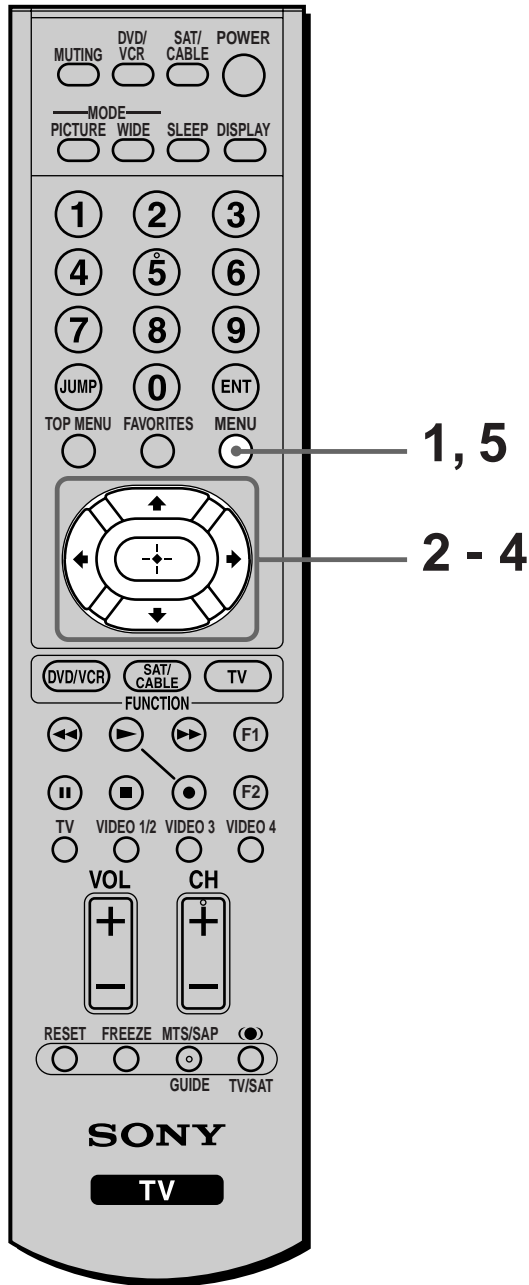

**1** Press MENU.

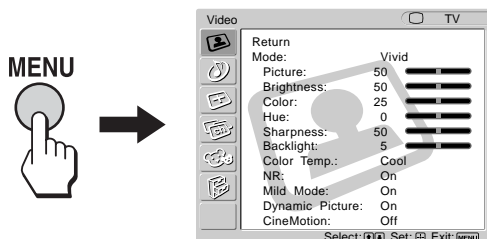

**2** Press  $\uparrow/\downarrow$  to select (Setup), then press  $\oplus$ .

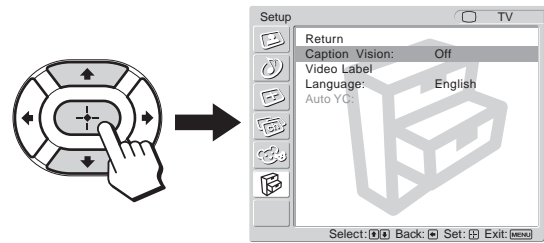

**3** Press  $\uparrow/\downarrow$  to select "Caption Vision" then press  $\oplus$ .

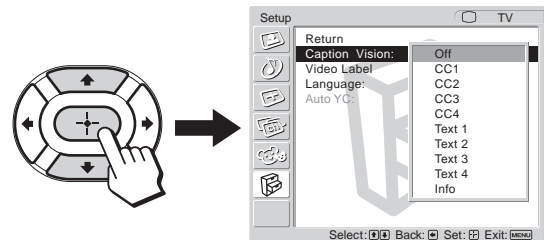

**4** Press  $\uparrow/\downarrow$  to select your desired Caption Vision, then press  $\oplus$ .

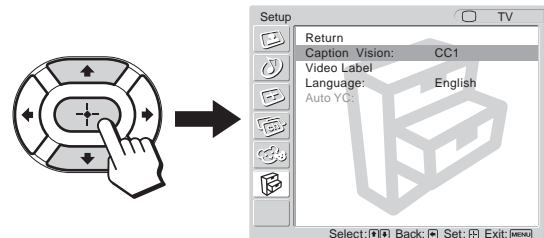

Select	To
Off	Turn off Caption Vision.
CC1, CC2, CC3, CC4	Display a printed version of the dialog or sound effects of a program. (The mode should be set to CC1 for most programs.)
Text 1, Text 2, Text 3, Text 4	Display network/station information presented using either half or the whole screen.
Info	Displays the program name and the time remaining in the program (if the broadcaster offers this service). Displays when the channel is changed or DISPLAY is pressed.

**5** Press MENU to exit the menu screen.

### Note

When the TV receives a 480p or higher resolution signal, "Caption Vision" cannot be selected.



# Selecting the Picture Mode

You can select one of three different Picture Modes that best suits the program you are watching. Furthermore, you can adjust the picture quality for each Picture Mode (see pages 57, 58). You can set a different Picture Mode for each video input that can be selected using the Input Select buttons, and store them in memory.

Press PICTURE repeatedly until the desired mode appears.

Each time you press the button, the Picture Mode changes as follows:

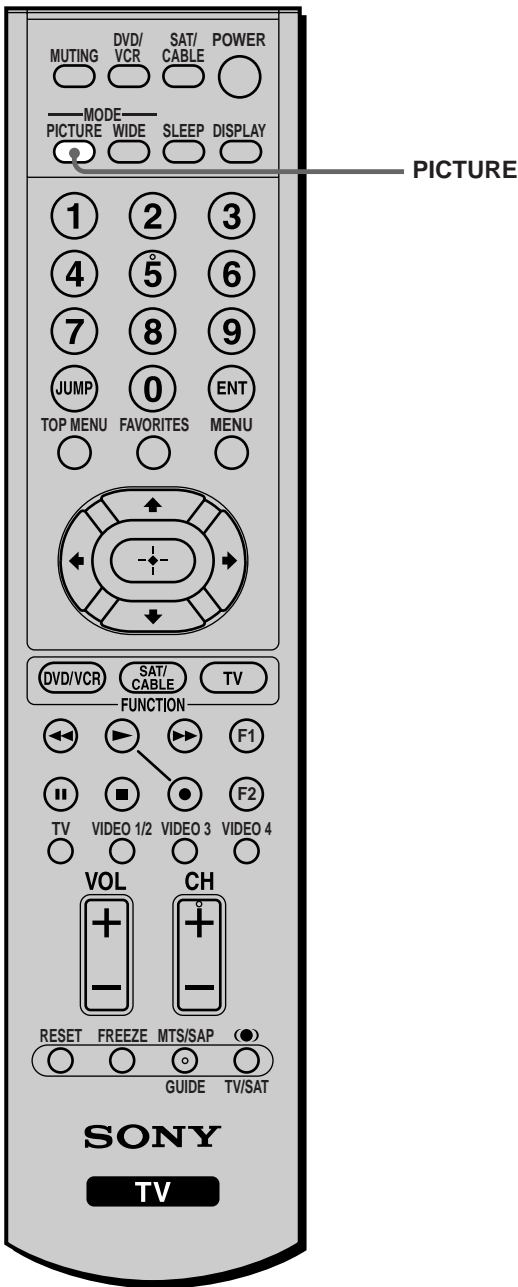
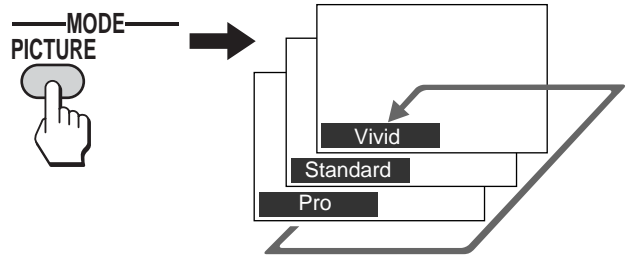

Picture Mode	Description
Vivid	Select for enhanced picture contrast and sharpness.
Standard	Select to display a picture with contrast to suit your room's lighting conditions. This mode is recommended for normal viewing conditions.
Pro	Select for professional monitor-like appearance.

**Tip**

You can adjust the picture quality options, such as "Picture," "Brightness," and "Color," for each Picture Mode (see pages 57, 58).

# Selecting the Effect Mode

“SRS WOW”\* creates a panoramic stereo audio image by producing deep and rich bass tones and clear treble tones, enabling you to enjoy powerful sounds effects like those in a movie theater. You can set the Effect mode for each video input that can be selected using the Input Select buttons, and store them in memory.

\* “SRS WOW” increases the sound quality of a diverse range of audio sources dramatically based on proprietary state-of-the-art technologies from SRS Labs, Inc. WOW, SRS and (●)® symbol are trademarks of SRS Labs, Inc. WOW technology is incorporated under license from SRS Labs, Inc.

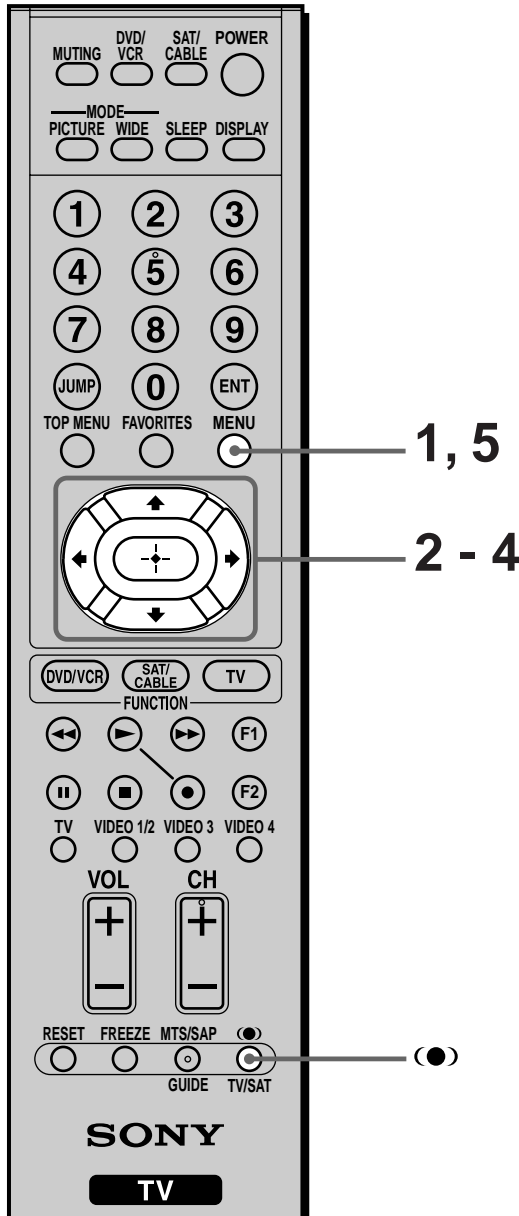

## Notes

- You cannot select the Effect mode if “Speaker” in the (🎵) (Audio) menu is set to “Off.”
- The Effect mode is valid only on the TV’s speakers. So you cannot enjoy sound effects of SRS WOW when you listen to a program through the AUDIO OUT jacks or on headphones.
- SRS WOW may be restricted in the effects it produces when you listen to a program in monaural.

## Tip

You can adjust other sound quality options. For details, see “Adjusting the Sound Quality” on page 59.

**1** Press MENU.

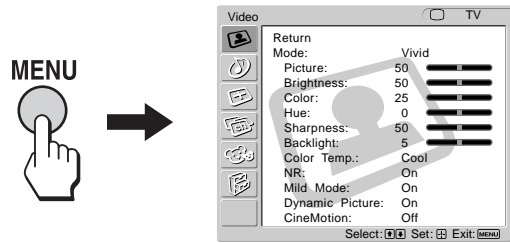

**2** Press ↑/↓ to select (🎵) (Audio), then press (⊕).

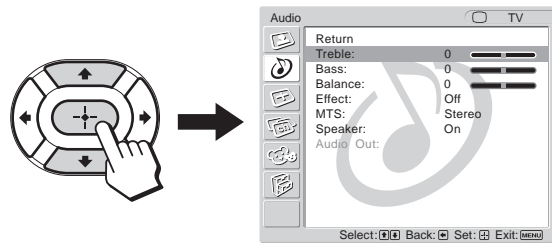

**3** Press ↑/↓ to select “Effect,” then press (⊕).

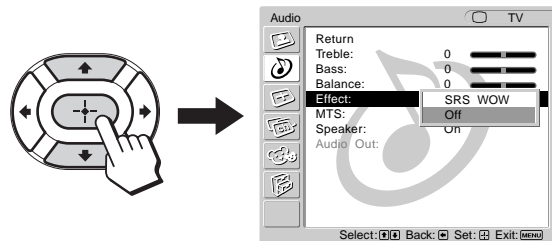

**4** Press ↑/↓ to select “SRS WOW” then press (⊕).

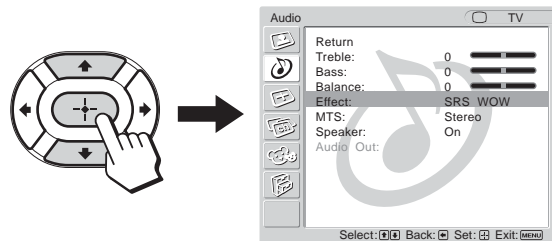

**5** Press MENU to exit the menu screen.

## Tip

Pressing the (●) button also lets you select “SRS WOW” and “Off.”

# Using the Wide Screen Mode

The Wide Screen Mode lets you watch any signals or other picture sizes such as Letterbox in several Wide Screen Modes (16:9 aspect ratio).

**Tip**

The “aspect ratio” is the ratio of width to height of the screen. 16:9 is also referred to as widescreen format.

Press WIDE repeatedly until the desired Wide Screen Mode appears.

Each time you press the button, the Wide Screen Mode changes as follows:

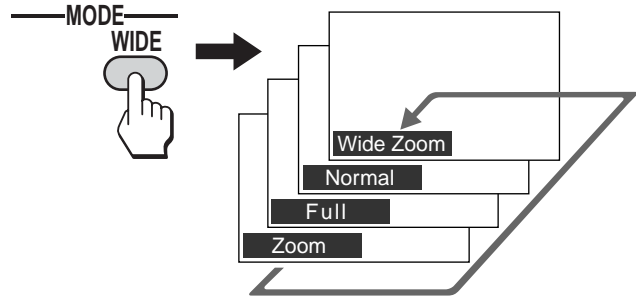

## Changing the Wide Screen Mode

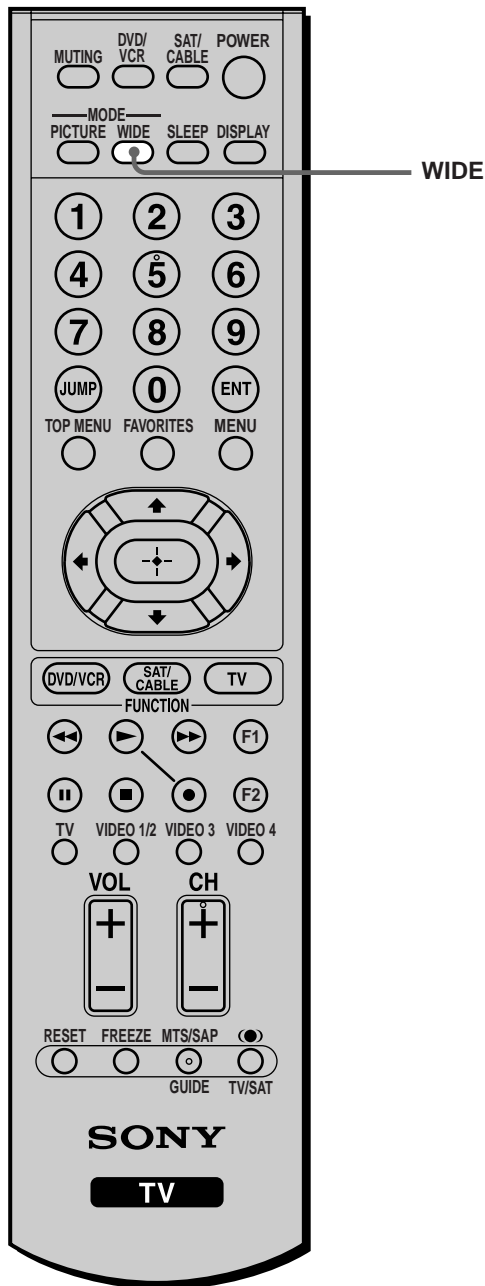

(Continued)

## Changing the Wide Screen Mode

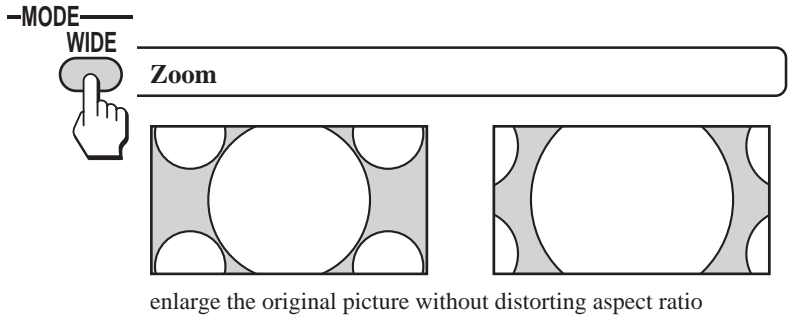
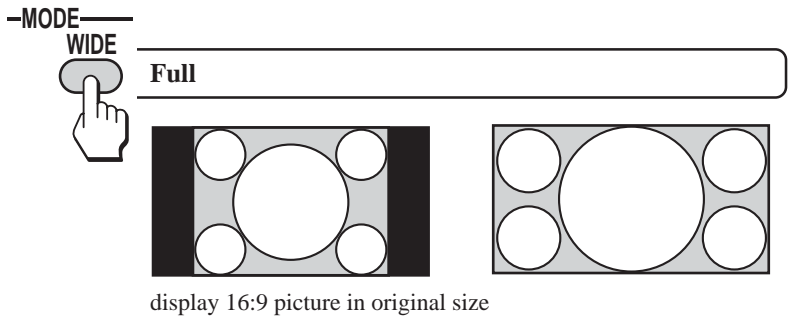
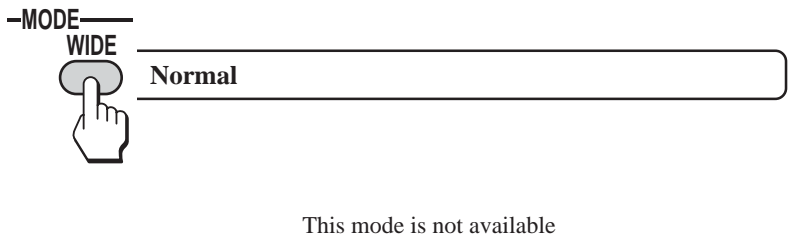
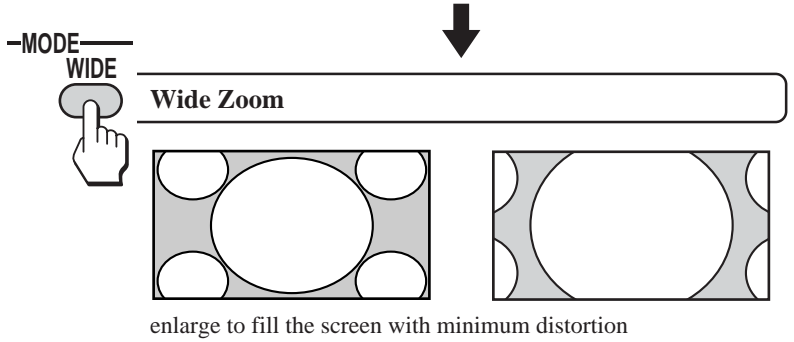
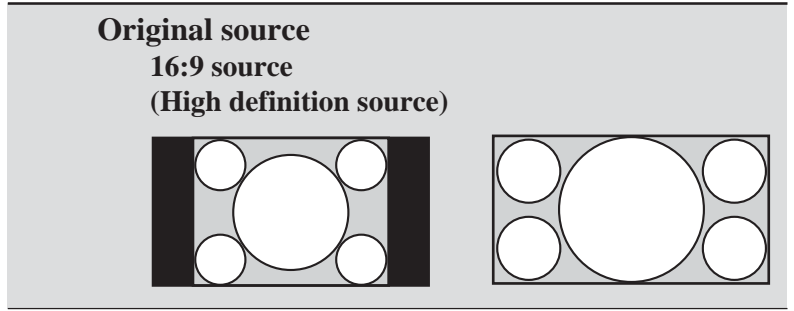
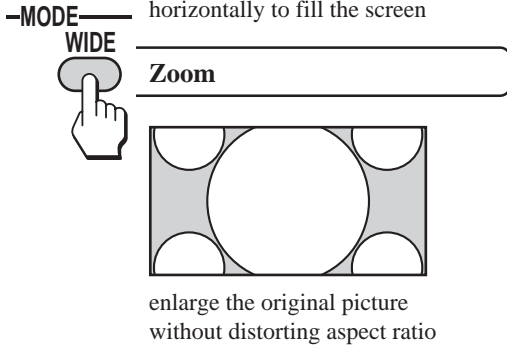
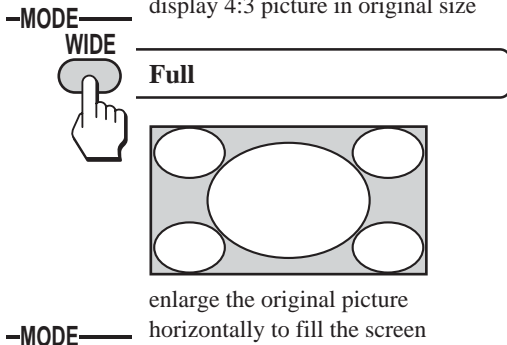
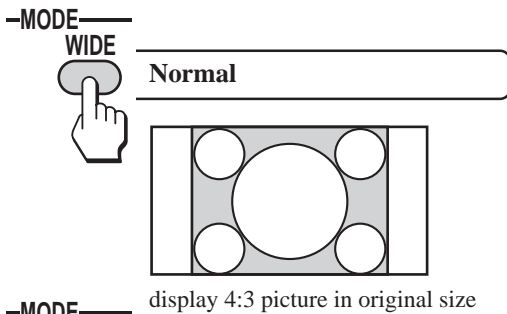
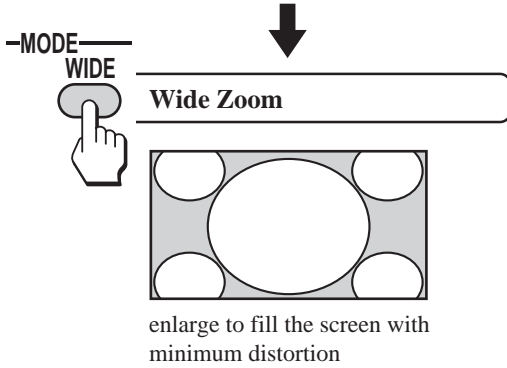
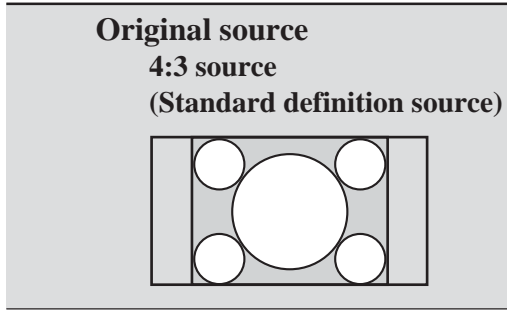

### Note

When the TV receives a 720p or 1080i signal, "Normal" cannot be selected.

### Tips

- When the TV receives a 720p or 1080i signal that is 4:3 aspect ratio picture with a black bar at each side, "Full" returns the picture to its original size.
- You can also access the Wide Screen Mode settings in the  (Screen) menu. For details, see page 47.

# Changing the Wide Screen Mode using the menu

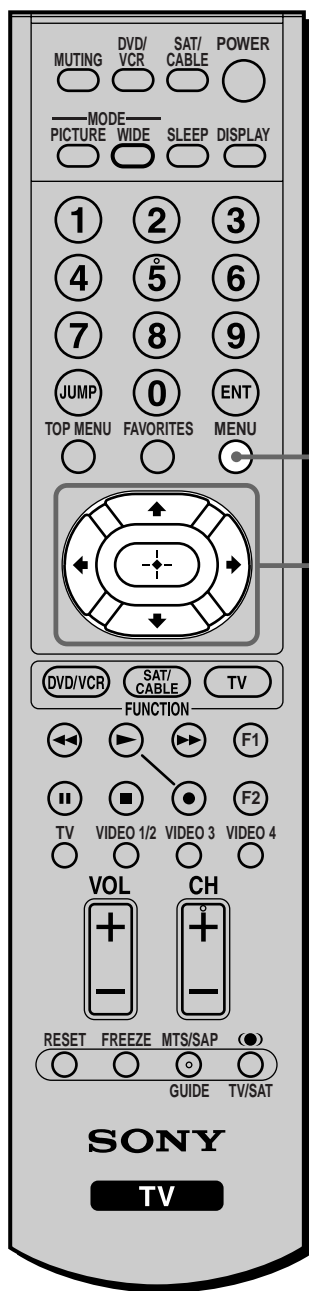

1, 5

2 - 4

1 Press MENU.

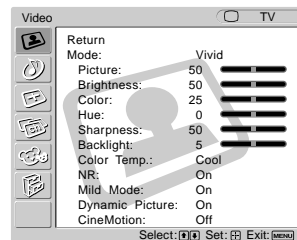

2 Press  $\uparrow/\downarrow$  to select , then press .

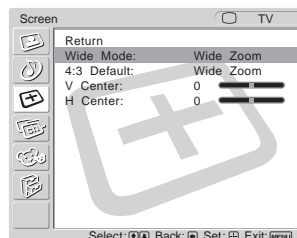
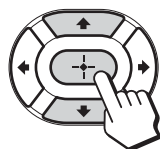

3 Press  $\uparrow/\downarrow$  to select the option you want to set, then press .

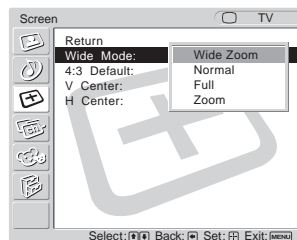
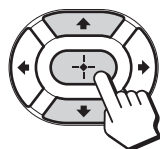

4 Press  $\uparrow/\downarrow$  to select the desired screen mode, then press .

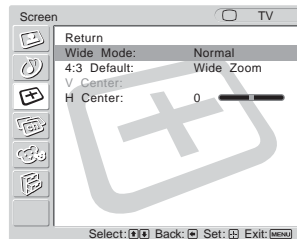
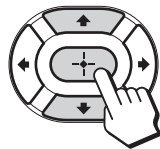

5 Press MENU to exit the menu screen.

## The Wide Screen Mode options available in the (Screen) menu

Option		Description
<b>Wide Mode</b> Select a Wide Mode to use for 4:3 sources.	Wide Zoom	Select to enlarge to fill the screen with minimum distortion.
	Normal	Select to display 4:3 picture in original size when the original source is 4:3 (Standard definition source).
	Full	Select to enlarge the original picture horizontally to fill the screen when the original picture is 4:3 (Standard definition source). When the original source is 16:9 (High definition source), select this mode to display 16:9 picture in original size.
	Zoom	Select to enlarge the original picture without distorting the aspect ratio.
<b>4:3 Default</b> Select the default Screen Mode to use for 4:3 sources.	Wide Zoom	Select to enlarge the 4:3 picture to fill the 16:9 screen, keeping the original image as much as possible.
	Normal	Select to return the 4:3 picture to its original size.
	Full	Select to enlarge the 4:3 picture horizontally only, to fill the 16:9 screen.
	Zoom	Select to enlarge the 4:3 picture horizontally and vertically to an equal aspect ratio that fills the 16:9 screen. Useful for watching Letterbox movies.
	Off	Select to continue using the current Wide Screen Mode setting when the channel or input is changed.

### Tip

To change from one Wide Screen Mode to another, use the WIDE button on the remote control.

### Notes

- The 4:3 Default functions only when the TV receives 480i or 480p signals.
- If “4:3 Default” is set to anything but “Off,” the Wide Screen Mode setting changes only for the current channel. When you change channels (or inputs), the Wide Screen Mode is automatically replaced with the 4:3 Default setting. To retain the current Wide Screen Mode setting as channels and inputs are changed, set “4:3 Default” to “Off.”

### Notes on the Wide Screen Mode

- The Wide Screen Mode function of this TV allows for various display options: select the appropriate Wide Screen Mode for the original aspect ratio of the picture you are watching.
- If you change the screen size using the Wide Screen Mode feature with the TV installed in a public space for commercial use or public purpose, it might be an infringement of copyright.
- If you select “Wide Zoom” when watching the picture with 4:3 aspect ratio, part of the picture is distorted. You can watch the picture with its original aspect ratio in “Normal” mode.
- The upper and lower parts of the picture may not appear in the screen according to the size of the original picture. In this case, adjust the picture position (see pages 55, 56).

# Using the Freeze Function

You can use this feature to write down information such as phone numbers, recipes, etc.

When the program information you want to capture is displayed, press FREEZE. The picture freezes. Press FREEZE again, and the frozen picture is released, and the picture begins to move again.

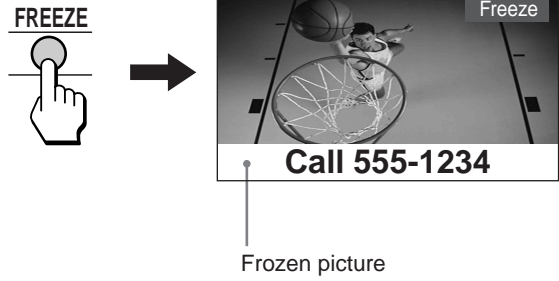
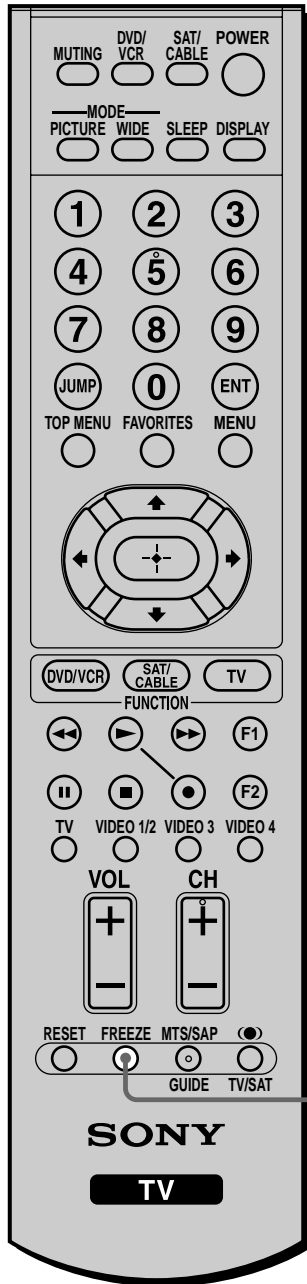

**Tip**  
While the picture is frozen, the sound continues to be output normally.

# Setting the Video Inputs

You can enjoy images (and sound) from optional video equipment connected to this unit by selecting the appropriate input. For details on connection, see pages 24 through 35(Continued).

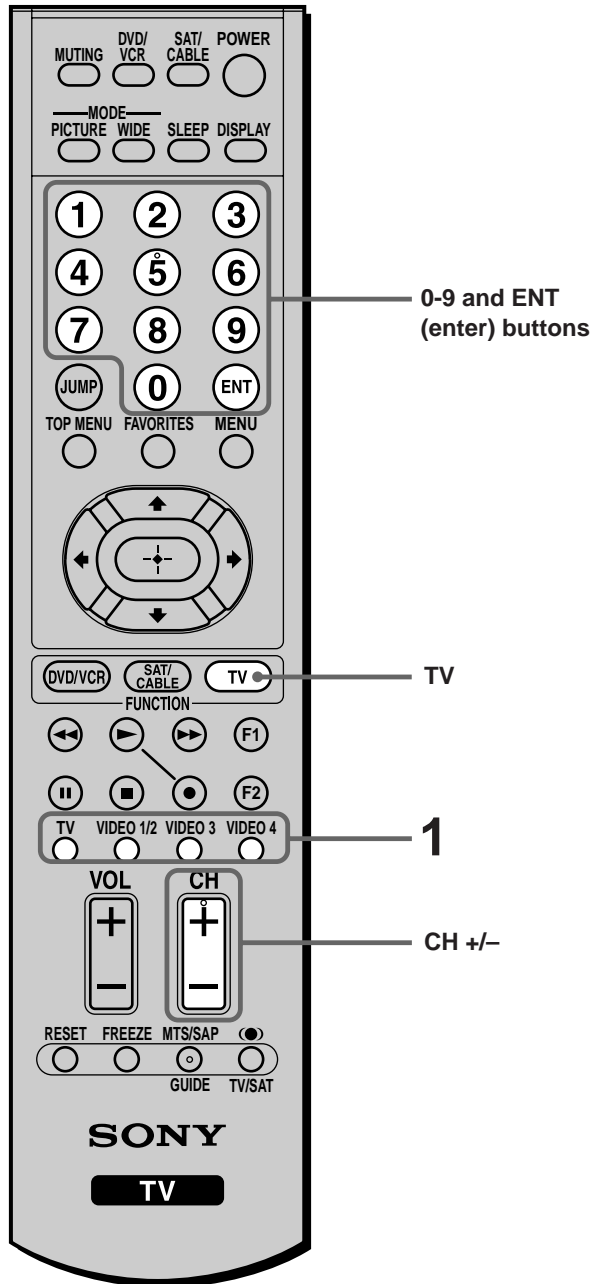

## 1 For video input 1 and 2

Press VIDEO 1/2 repeatedly until the desired video input appears.

Each time you press VIDEO 1/2, the input changes as follows.

Select	Display indication
• VIDEO 1 IN	Video 1 ↑ ↓
• VIDEO 2 IN	Video 2

## For video input 3 (HD/DVD 3 IN)

Press VIDEO 3.

“Video 3”\* indication appears.

## For video input 4 (HDMI 4 IN)

Press VIDEO 4.

“Video 4”\* indication appears.

\* The type of picture signal (480i, 480p, 720p, or 1080i) appears under “Video 3” and “Video 4.”

### Tips

- When “Skip” is selected as a label using “Video Label” in the  (Setup) menu, the selected input will be skipped in the cycle (see page 51).
- You can also select the inputs by using the TV/VIDEO button on the TV.

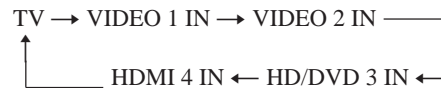

- When you have preset a label for each video input using “Video Label” in the  (Setup) menu, the label will be displayed (see page 51).

## 2 Operate the selected optional equipment.

For details, see “Using your Remote Controls with Other Equipment” on page 18, or refer to the instructions supplied with each equipment.

### To return to watching the TV

Press TV, any of 0 - 9 and ENT (enter) or CH +/-.

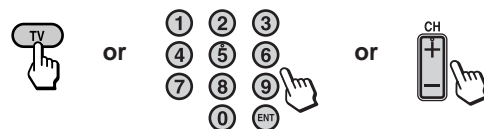



# Using the Video Label and Skip Feature

You can make settings for each video input by choosing the label displayed on the screen.

## Tip

If you select "Skip," your TV skips this input when you press the Input Select buttons.

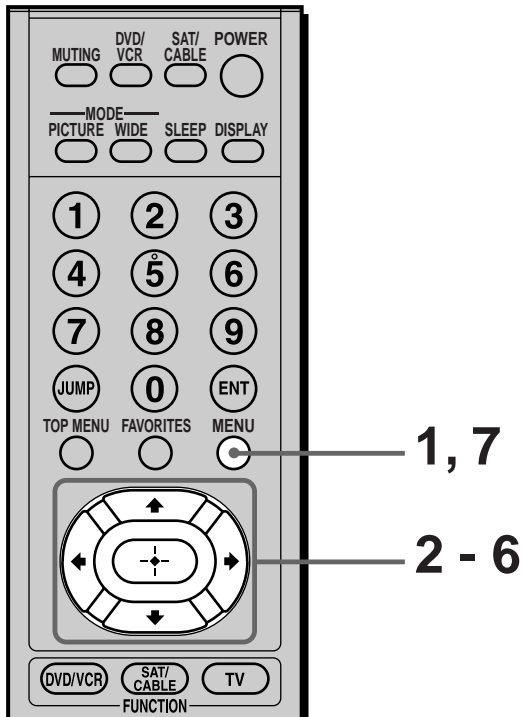

**1** Press MENU.

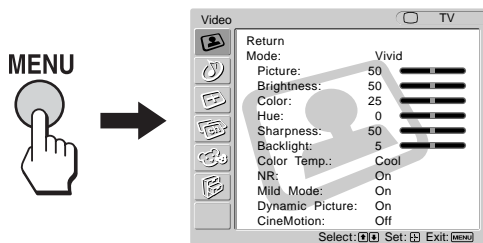

**2** Press  $\uparrow/\downarrow$  to select (Setup), then press  $\odot$ .

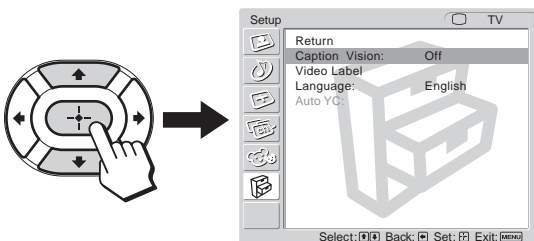

**3** Press  $\uparrow/\downarrow$  to select "Video Label," then press  $\odot$ .

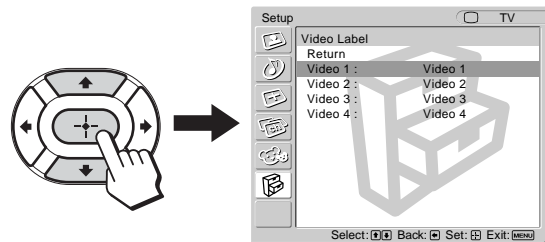

**4** Press  $\uparrow/\downarrow$  to select the video input (Video 1-4) you want to assign a label, then press  $\odot$ .

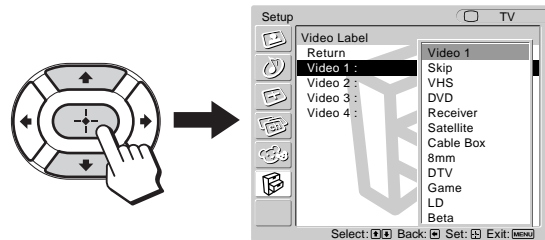

**5** Press  $\uparrow/\downarrow$  to select the label, then press  $\odot$ .

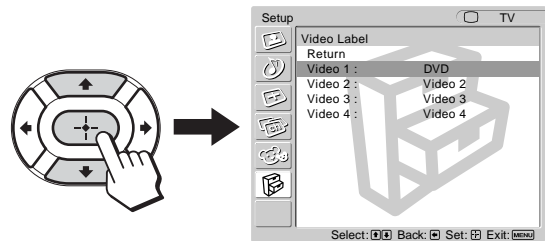

## To skip the unused video input using the Input Select buttons

Press  $\uparrow/\downarrow$  to select "Skip."

**6** Repeat steps 4 and 5 to assign labels to more video inputs.

You can select a label for each video input displayed on the screen.

Video 1, 2	Skip, VHS, DVD, Receiver, Satellite, Cable Box, 8mm, DTV, Game, LD, Beta
Video 3, 4	Skip, DVD, Satellite, Cable Box, DTV, HD

**7** Press MENU to exit the menu screen.

# Using Favorite Channels

You can select program channels from a list of favorite channels that you preset.

## Setting your favorite channels

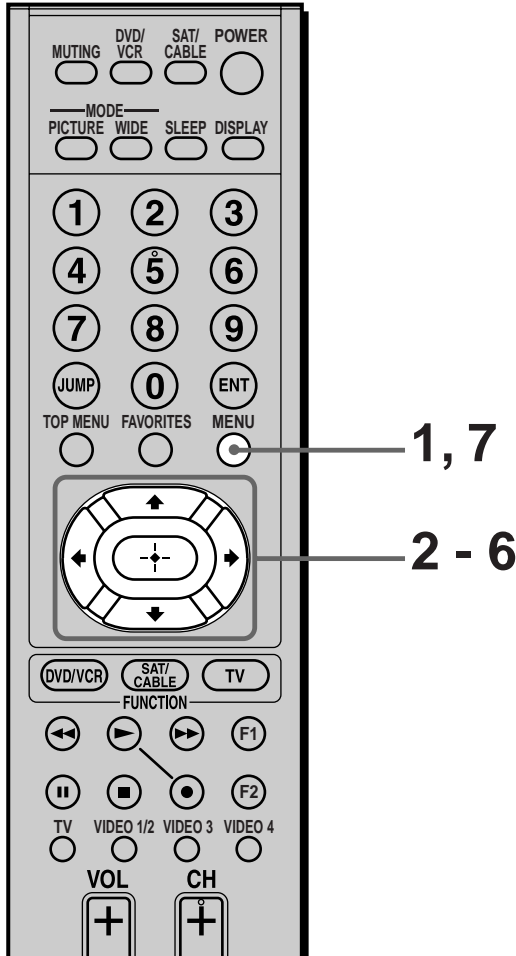

**1** Press MENU.

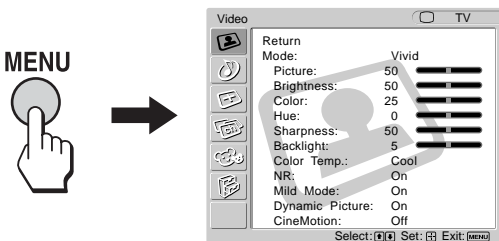

**2** Press  $\uparrow/\downarrow$  to select (Channel), then press  $\leftarrow$ .

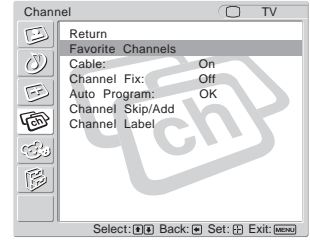
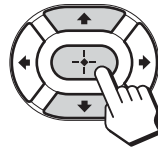

**3** Press  $\uparrow/\downarrow$  to select "Favorite Channels," then press  $\leftarrow$ .

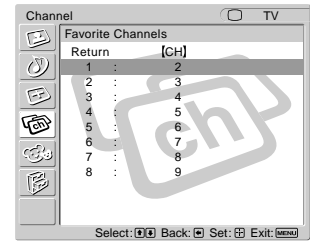
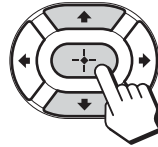

### Tip

If you cannot select "Favorite Channels," change the input to TV by pressing the TV button.

**4** Press  $\uparrow/\downarrow$  to select the position you want to change, then press  $\leftarrow$ .

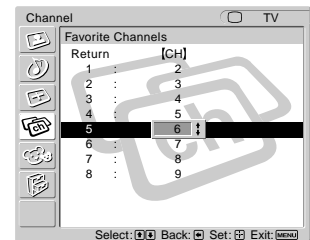
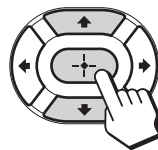

**5** Press  $\uparrow/\downarrow$  to scroll through the channels until you find the desired channel, then press  $\leftarrow$ .

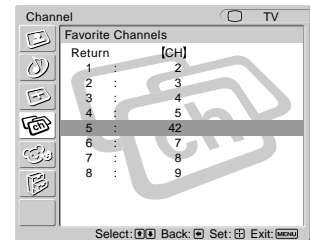

**6** Repeat steps 4 and 5 to program other favorite channels.

**7** Press MENU to exit the menu screen.

## Watching favorite channels

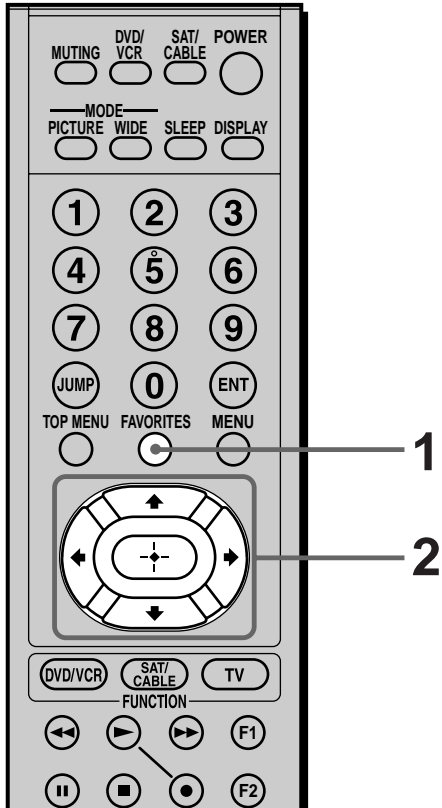

### 1 Press FAVORITES.

The Favorite Channels list appears.



### 2 Press $\uparrow/\downarrow$ to select the desired channel, then press $\oplus$ .

The selected channel will be displayed.

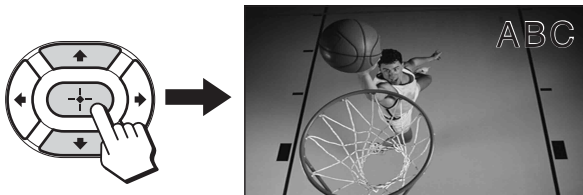

### Tip

If you make an optional label using “Channel Label” in the (Channel) menu, that label will be displayed on the screen.

## Using the Channel Label Feature

If you have set an optional label for the channel display or for Favorite Channels, you can have that label displayed on the screen.

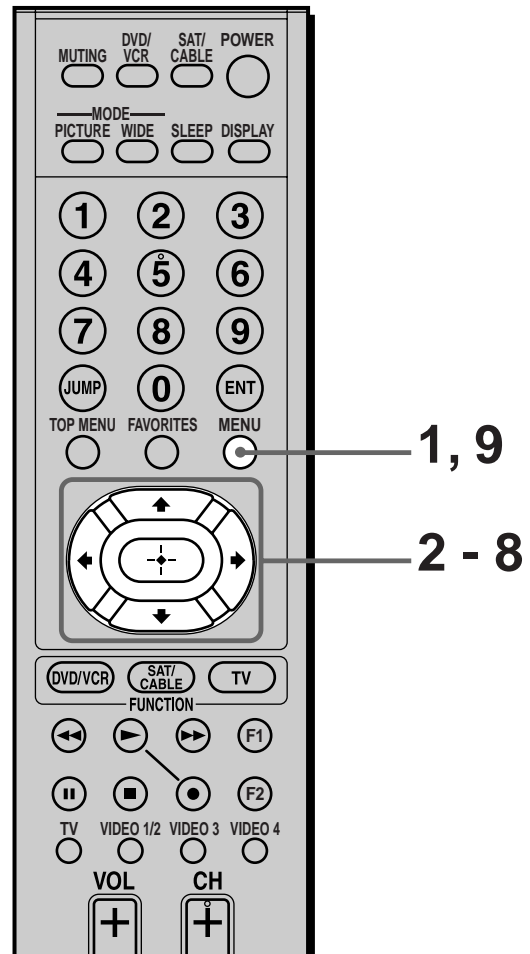

### 1 Press MENU.

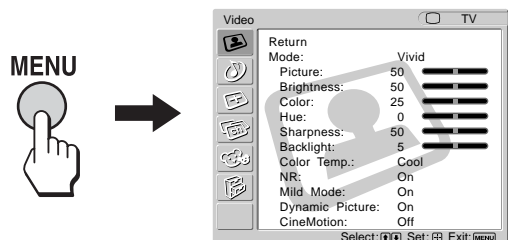

(Continued)

- 2 Press  $\uparrow/\downarrow$  to select  (Channel), then press .

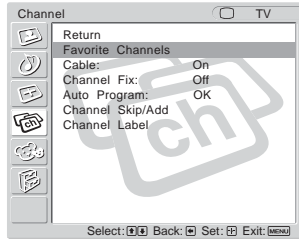

- 3 Press  $\uparrow/\downarrow$  to select "Channel Label," then press .

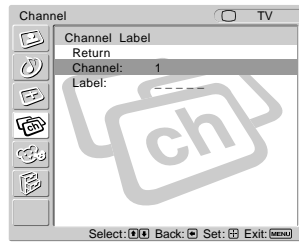
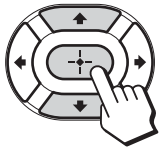

- 4 Press  $\uparrow/\downarrow$  to select "Channel," then press .

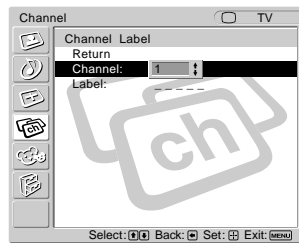
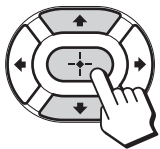

- 5 Press  $\uparrow/\downarrow$  to scroll through the channel numbers you want to assign a label, then press .

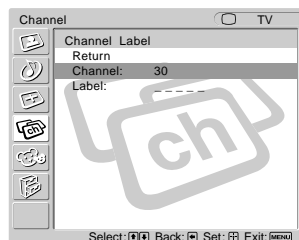
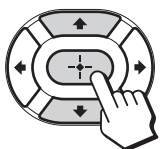

- 6 Press  $\uparrow/\downarrow$  to select "Label," then press .

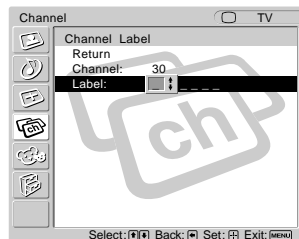

- 7 Press  $\uparrow/\downarrow$  to scroll through the label characters (A-Z, 0-9, etc.), then press .

You can add up to 5 characters to the label.

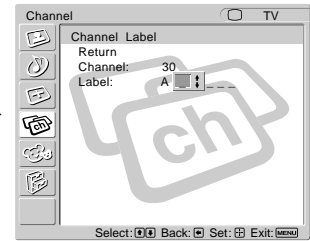

- 8 Repeat steps 4 - 7 to assign labels to more channels.

- 9 Press MENU to exit the menu screen.

### Tip

Press the RESET button to clear the channel label when you open the "Channel Label" option or "Label" option.

# Using Advanced Features

## Adjusting the Picture Position Vertically

You can move the position of the picture up and down for each Wide Screen Mode (page 45) in the following cases:

- To move the position of the picture in “Wide Zoom” and “Zoom” modes
- When subtitles may not fit in the screen

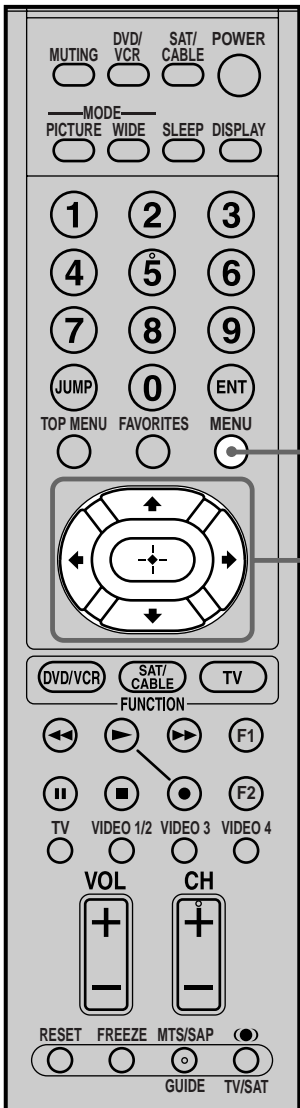

1, 5

2 - 4

- 1 Receive the picture you want to adjust, then press MENU.

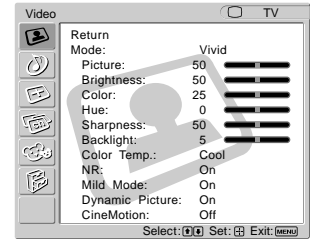

- 2 Press  $\uparrow/\downarrow$  to select  $\boxed{+}$  (Screen), then press  $\boxed{+}$ .

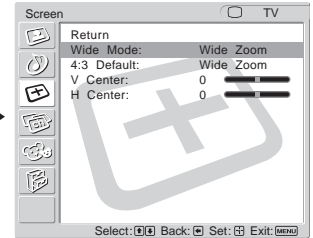
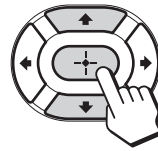

- 3 Press  $\uparrow/\downarrow$  to select “V Center,” then press  $\boxed{+}$ .

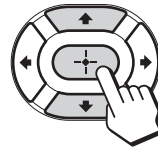

- 4 Press  $\uparrow/\downarrow/\leftarrow/\rightarrow$  to adjust the position, then press  $\boxed{+}$ .

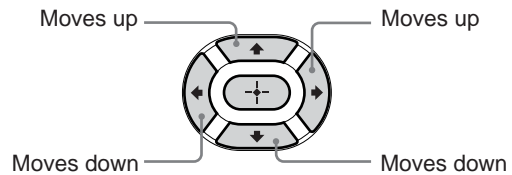

- 5 Press MENU to exit the menu screen.

### Note

“V Center” cannot be adjusted when “Normal” or “Full” is selected in “Wide Mode.”

# Adjusting the Picture Position Horizontally

You can move the position of the picture left and right. This function allows for horizontal adjustment of the picture being displayed.

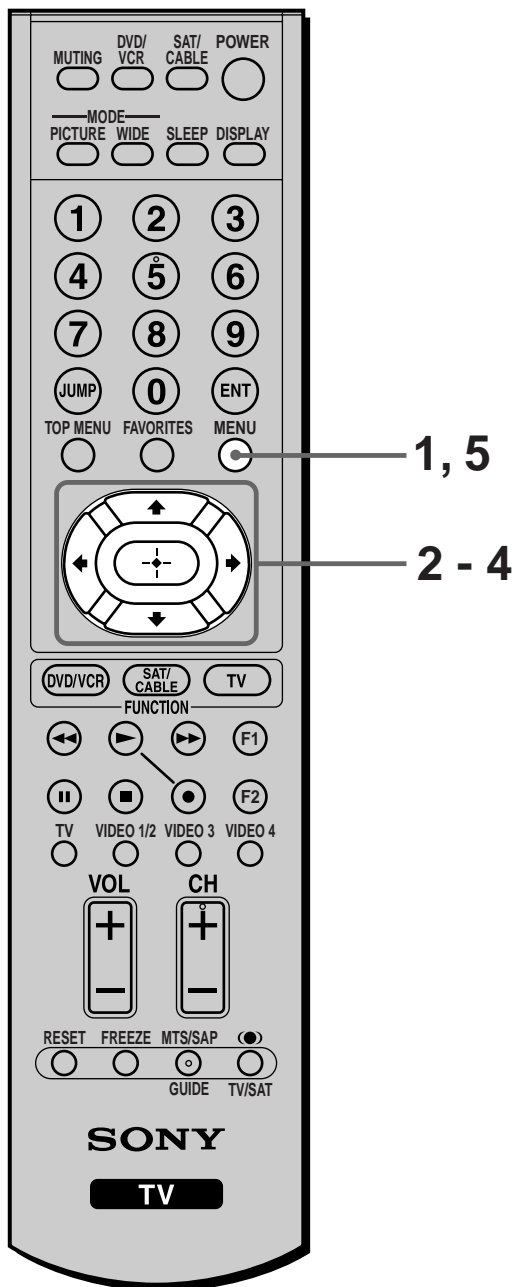

**1** Receive the picture you want to adjust, then press MENU.

MENU

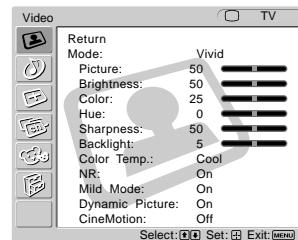

**2** Press  $\uparrow/\downarrow$  to select  $\oplus$  (Screen), then press  $\odot$ .

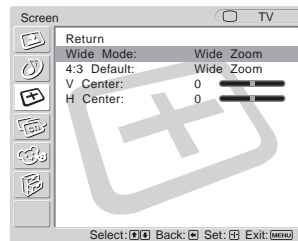
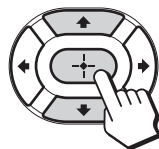

**3** Press  $\uparrow/\downarrow$  to select "H Center," then press  $\odot$ .



**4** Press  $\uparrow/\downarrow/\leftarrow/\rightarrow$  to adjust the position, then press  $\odot$ .

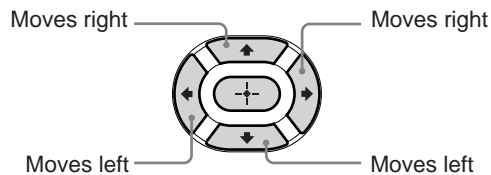

**5** Press MENU to exit the menu screen.

## Tips

- "H Center" can be adjusted for every input setting.
- The "H Center" is useful if the TV is connected to game equipment.

# Adjusting the Picture Quality

You can adjust the picture quality for each Picture Mode (“Vivid,” “Standard,” or “Pro”).

You can adjust the picture quality for each video input selected using the Input Select buttons, and store these adjustments in memory.

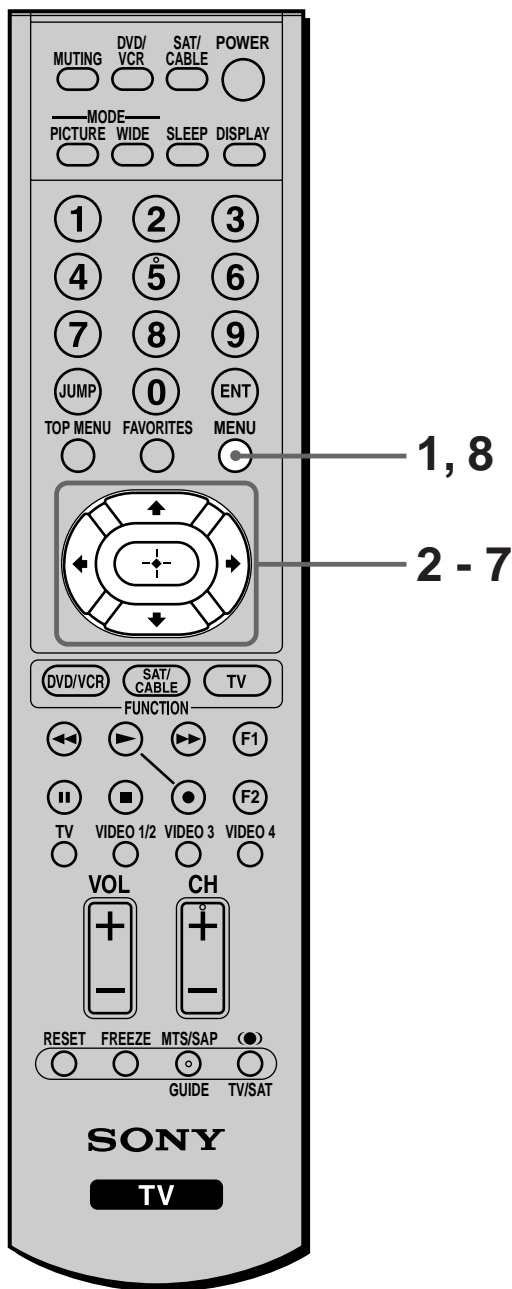

1 Press MENU.

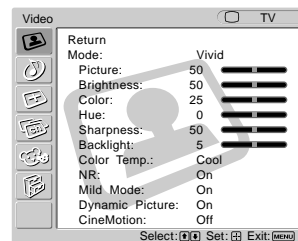
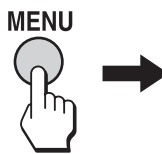

2 Press  $\uparrow/\downarrow$  to select (Video), then press .

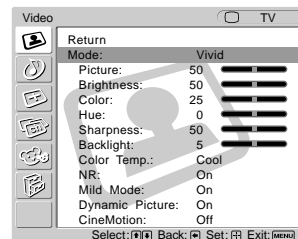
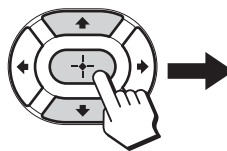

3 Press  $\uparrow/\downarrow$  to select “Mode,” then press .

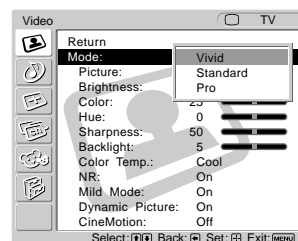
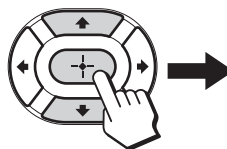

4 Press  $\uparrow/\downarrow$  to select the Picture Mode you want to adjust, then press .

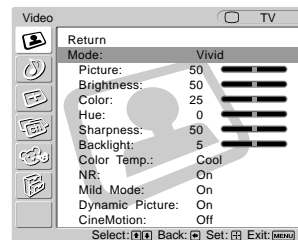
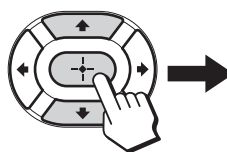

5 Press  $\uparrow/\downarrow$  to select “Picture,” then press .

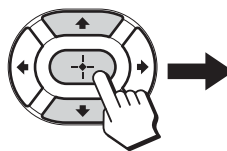

(Continued)

- 6 Press  $\uparrow/\downarrow/\leftarrow/\rightarrow$  to make the desired adjustment, then press  $\ominus$ .

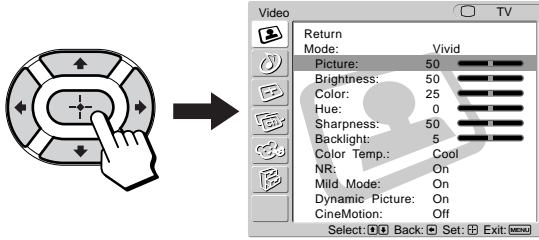

### Adjustable options

Option	Press $\downarrow/\leftarrow$	Press $\uparrow/\rightarrow$
Picture	To reduce picture contrast.	To enhance picture contrast.
Brightness	To darken the picture.	To brighten the picture.
Color	To decrease color intensity.	To increase color intensity.
Hue*	To decrease the green tones.	To increase the green tones.
Sharpness	To soften the picture.	To sharpen the picture.
Backlight	To darken the screen.	To brighten the screen.

\* The adjustment is not available for the following:  
 – 480i, 480p, 1080i and 720p signals input to HD/DVD 3 IN and HDMI 4 IN

### Tip

You can adjust each option by referring to the value beside each option indicator.

### Selective options

Option	Description	Setting
Color Temp. (Color Temperature)	Select to give white colors a blue (Cool) or a red (Warm) tint.	Cool/ Neutral/ Warm
NR (Noise Reduction)	Select to reduce the noise level of connected equipment. It is also effective on the signal from the VHF/UHF jack.	On/Off
Mild Mode	Select for a natural, soft picture.	On/Off
Dynamic Picture	Select to enhance the picture contrast.	On/Off
CineMotion	Select to provide an optimized display by automatically detecting film content. Moving pictures will become clearer and more natural. When the superimposed text on the film content appears corrupted, set “CineMotion” to “Off.”	On/Off

### Tip

“CineMotion” is only available for 480i input signal from VHF/ UHF, VIDEO 1 IN, VIDEO 2 IN, HD/DVD 3 IN and HDMI 4 IN.

- 7 Repeat steps 5 and 6 to adjust other options.

- 8 Press MENU to exit the menu screen.

### To reset to the factory settings

Press RESET while the menu is on the screen and the cursor is located on the right side of any menu item. When the pop-up window or bar indication is displayed, only the menu item being adjusted is reset to the factory settings.

**RESET**

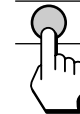



# Adjusting the Sound Quality

You can adjust the sound quality for each video input selected using the Input Select buttons, and store these adjustments in memory.

For details on the Effect mode, see page 44.

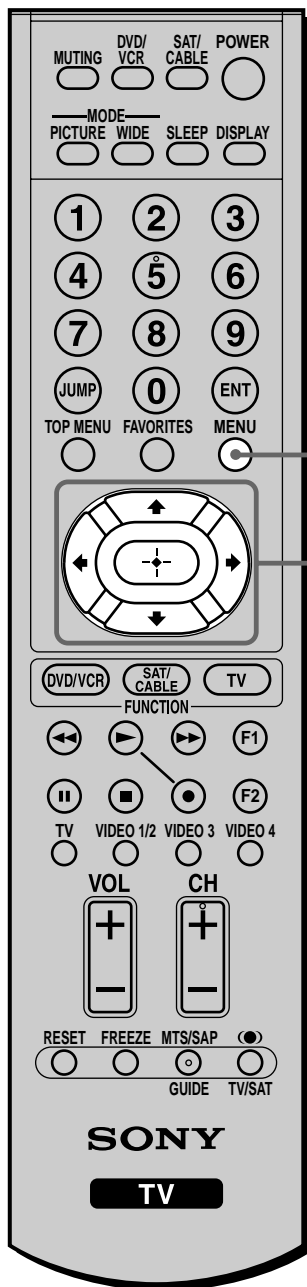

1 Press MENU.

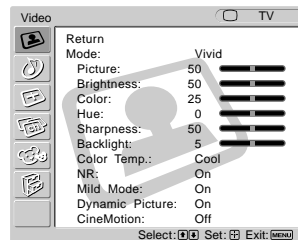

2 Press  $\uparrow/\downarrow$  to select  (Audio), then press  $\oplus$ .

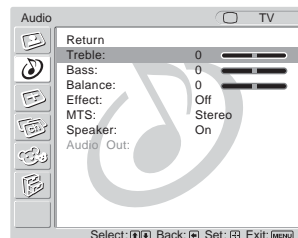
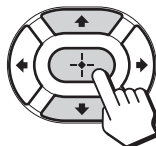

3 Press  $\uparrow/\downarrow$  to select the option you want to adjust, then press  $\oplus$ .

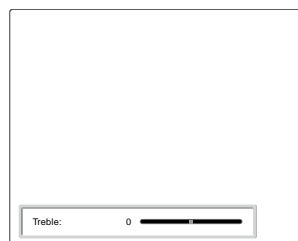
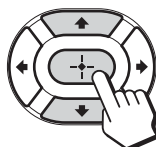

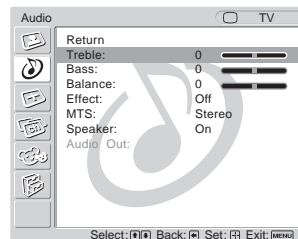
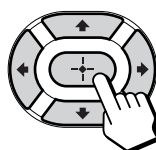

4 Press  $\uparrow/\downarrow/\leftarrow/\rightarrow$  to make the desired adjustment, then press  $\oplus$ .



(Continued)

Option	Press ↓/←	Press ↑/→
Treble*	To decrease higher-pitched sounds.	To increase higher-pitched sounds.
Bass*	To decrease lower-pitched sounds.	To increase lower-pitched sounds.
Balance*	To emphasize the left speaker.	To emphasize the right speaker.
Effect**	See page 44.	

\* To adjust any of these options, set “Speaker” in the  (Audio) menu to “On,” or “Audio Out” to “Variable” first.

\*\* To adjust the option, set “Speaker” in the  (Audio) menu to “On” first.

### Tip

You can adjust each option by referring to the value beside each option indicator.

**5** Repeat steps 3 and 4 to adjust other options.

**6** Press MENU to exit the menu screen.

### To reset to the factory settings

Press RESET while the menu is on the screen and the cursor is located on the right side of any menu item. When the pop-up window or bar indication is displayed, only the menu item being adjusted is reset to the factory settings.

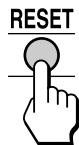

### Note

Resetting the unit to the factory settings resets only “Treble,” “Bass” and “Balance.”

## Selecting Stereo or Bilingual Programs

You can enjoy stereo, bilingual and mono programs.

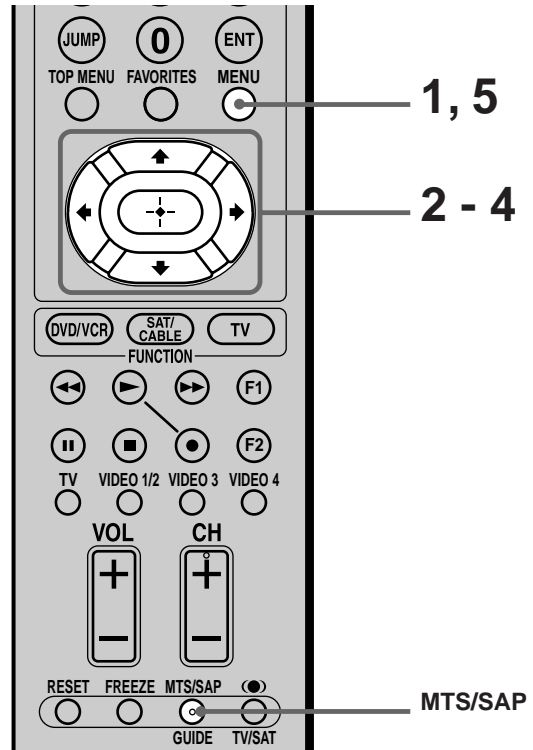

Press MTS/SAP repeatedly until the desired sound indication appears.

Each time you press the button, the sound indication changes as follows:

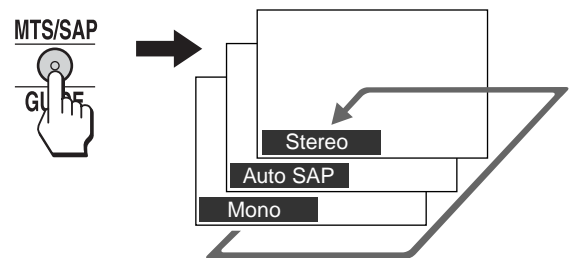

Sound indication*	Description
Stereo	Select for stereo reception when viewing a program broadcast in stereo.
Auto SAP	Select to automatically switch the TV to second audio programs when a signal is received. (If no SAP signal is present, the TV remains in Stereo mode.)
Mono	Select for mono reception. (Use to reduce noise during weak stereo broadcasts.)

\* This is available only for VHF/UHF input.

## Selecting stereo or bilingual programs using the menu

1 Press MENU.

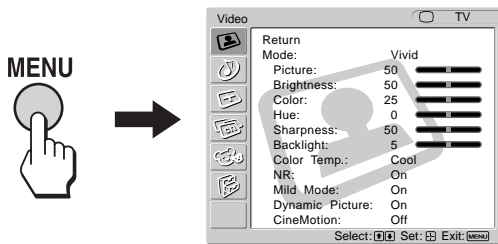

2 Press  $\uparrow/\downarrow$  to select (Audio), then press  $\ominus$ .

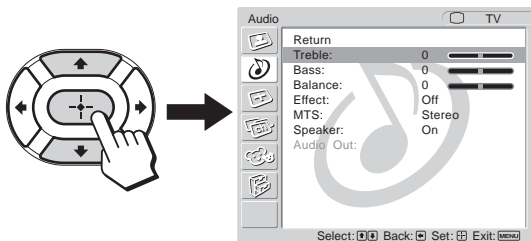

3 Press  $\uparrow/\downarrow$  to select "MTS," then press  $\ominus$ .

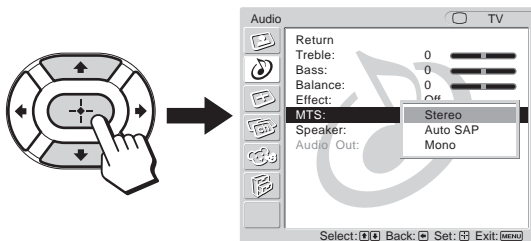

4 Press  $\uparrow/\downarrow$  to select the desired reception, then press  $\ominus$ .

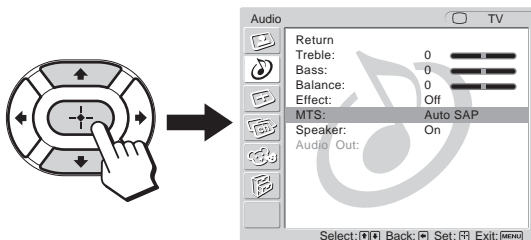

5 Press MENU to exit the menu screen.

## Selecting the TV Speakers or an External Amplifier to Listen to the TV

You can select if you want to listen to the TV from the TV speakers or from an external amplifier connected to the TV's audio outputs.

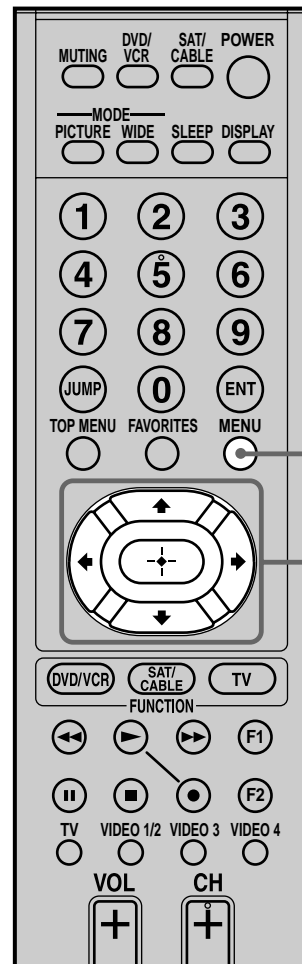

1 Press MENU.

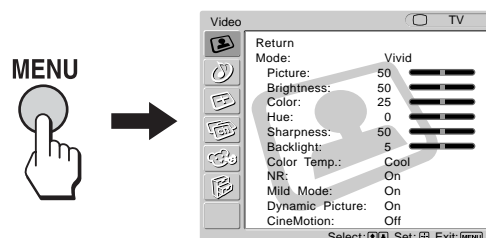

(Continued)

2 Press  $\uparrow/\downarrow$  to select  (Audio), then press .

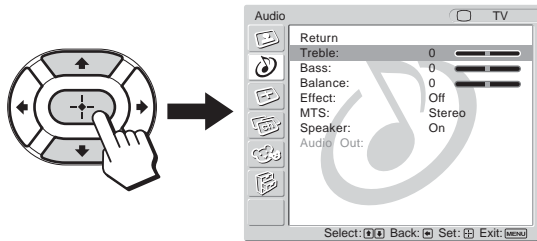

3 Press  $\uparrow/\downarrow$  to select "Speaker," then press .

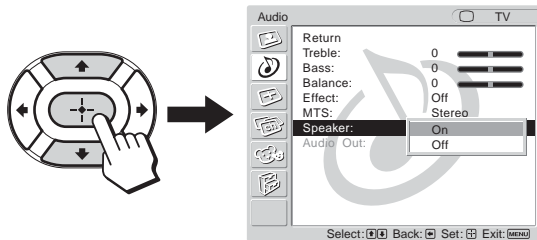

Option	Description	
Speaker	On	Select to turn on the TV speakers.
	Off	Select to turn off the TV speakers and listen to the TV's sound only through your external audio system speakers.

4 Press  $\uparrow/\downarrow$  to select the desired option, then press .

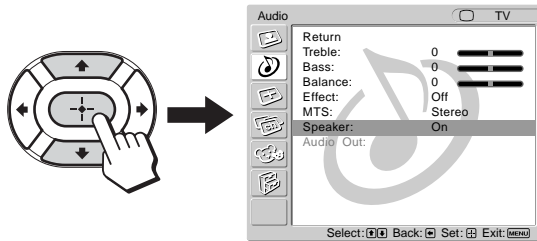

5 Press MENU to exit the menu screen.

## Selecting How to Control the Volume of the TV's Speakers

You can select how to control the volume of the TV's speakers when an external amplifier is connected to the TV's audio outputs.

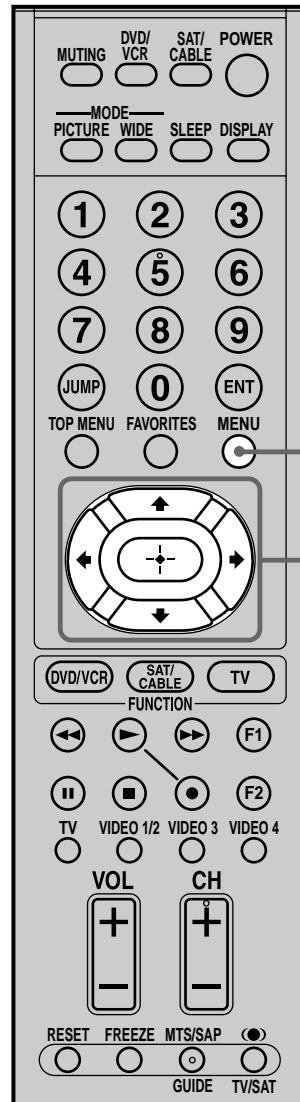

1 Press MENU.

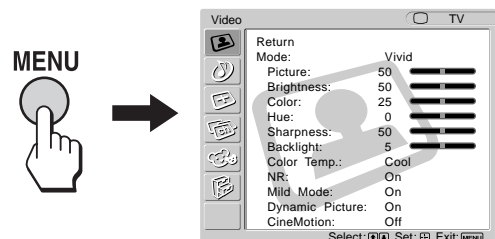

2 Press  $\uparrow/\downarrow$  to select  (Audio), then press .

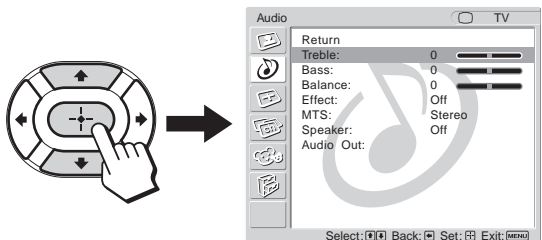

3 Press  $\uparrow/\downarrow$  to select “Audio Out,” then press .

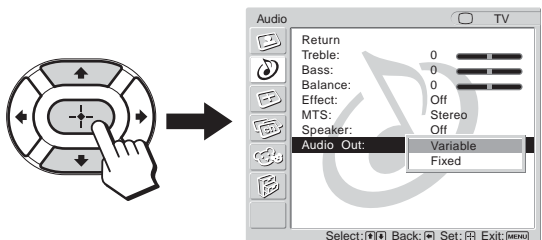

Option	Description	
Audio Out (Easy control of volume adjustments)	Variable	The TV’s speakers are turned off, but the audio output from your audio system can still be controlled by the TV’s remote control.
	Fixed	The TV’s speakers are turned off and the audio output of the TV is fixed. Use your AV receiver’s remote control to adjust the volume (and other audio settings) through your audio system.

4 Press  $\uparrow/\downarrow$  to select the desired option, then press .

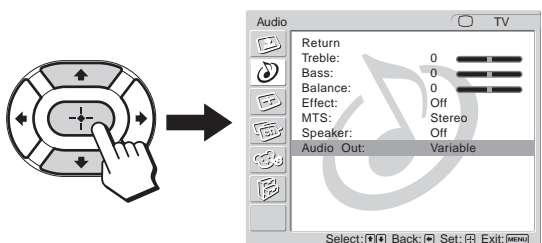

5 Press MENU to exit the menu screen.

**Note**

“Audio Out” can be selected only when the “Speaker” is set to “Off.”

## Using the Parental Control Feature

The TV programs and movies shown on TV are given a rating signal based on the following rating systems.

**In U.S.A.:** U.S. Television Parental Guidelines to rate television programs (U.S. TV ratings), and Motion Picture Association of America (MPAA) Guidelines to rate movies including those shown on TV (movie ratings).

**In Canada:** Canadian English Language ratings to rate television programs in English, and Canadian French Language ratings to rate those in French.

To block programs you feel unsuitable for your children, you need to set the TV for the desired rating systems. Sony’s predetermined ratings are also available. See page 68 for a description of the ratings.

The TV’s Parental Control feature functions by receiving the rating signal from your local broadcasting station or cable service provider.

# Activating the Parental Control feature

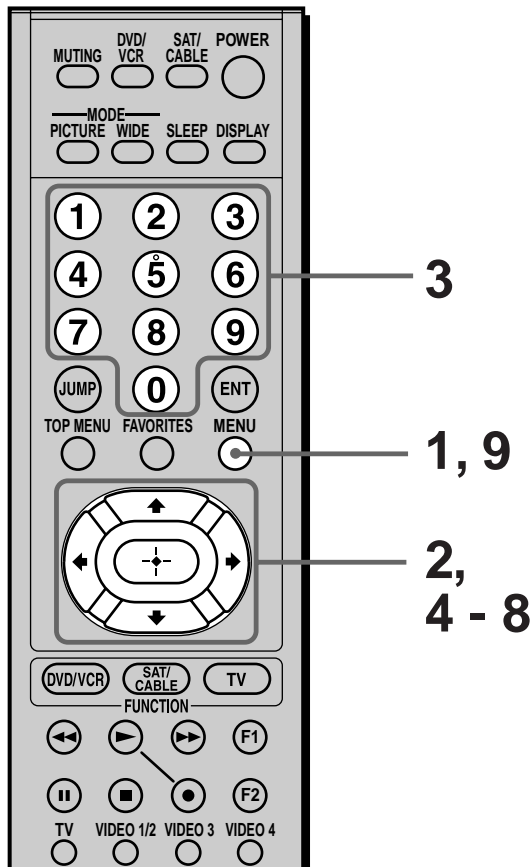

**1** Press MENU.

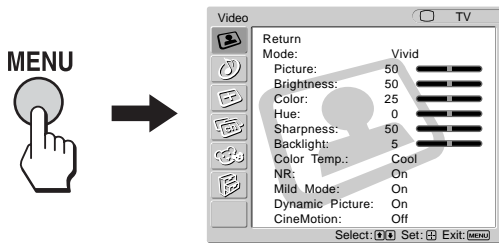

**2** Press  $\uparrow/\downarrow$  to select (Parent), then press  $\oplus$ .

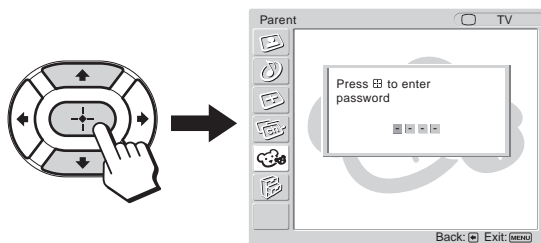

**3** Enter a four-digit password using the 0 - 9 buttons, then, press  $\oplus$ .

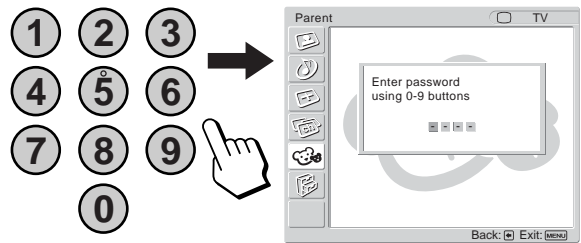

**4** The Parent menu options appear.

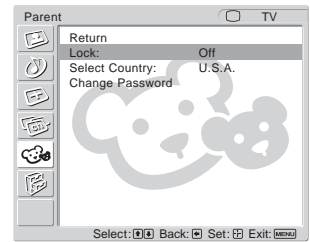

If you access the Parent menu for the first time, you are requested to enter the password again for confirmation.

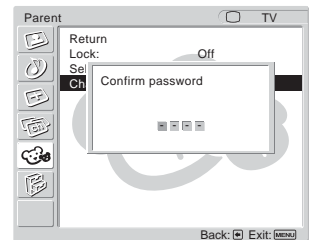

### Note

Do not enter "4357" corresponding to "HELP" on a phone number pad (see page 65).

### Tips

- You need to enter the password here for any further access into the Parent menu. If you lose your password, see "Tip" on page 65.
- If you want to change the password, see page 65.

**5** Press  $\uparrow/\downarrow$  to select "Select Country," then press  $\oplus$ .

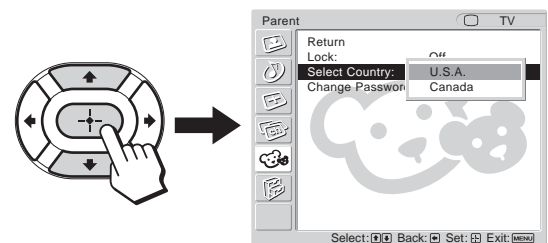

- 6** Press  $\uparrow/\downarrow$  to select your country/region (U.S.A. or Canada), then press  $\odot$ .

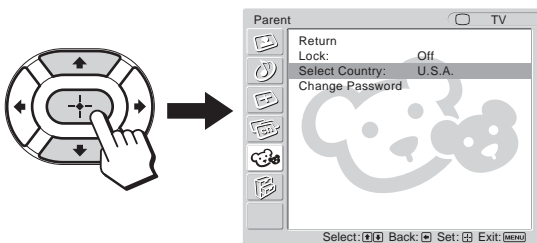

- 7** Press  $\uparrow/\downarrow$  to select “Lock,” then press  $\odot$ .

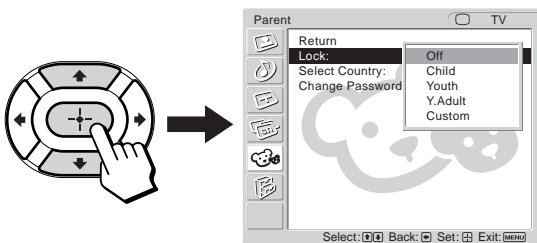

- 8** Press  $\uparrow/\downarrow$  to select a desired rating, then press  $\odot$ .

If you select “Child,” “Youth,” or “Y.Adult” (Young Adult), the Parental Control is activated automatically.

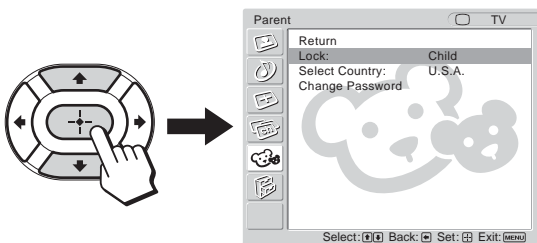

#### Tip

If you are not familiar with the Parental Guideline rating system, you should select “Child,” “Youth,” or “Y.Adult (Young Adult)” to help simplify the rating selection. To set more restrictive ratings, select “Custom” (see “Selecting a Custom Rating” on page 66).

- 9** Press MENU to exit the menu screen.

### To view blocked programs

You can view blocked programs by entering the password.

- 1 Press ENT (enter) when tuned to a blocked program.
- 2 Enter your four-digit password using the 0 - 9 buttons.

The Parental Control feature will be canceled temporarily until you turn the TV off.

### To deactivate the Parental Control feature

Set “Lock” to “Off” in the (Parent) menu.

### To change the password

- 1 Press MENU.
- 2 Press  $\uparrow/\downarrow$  to select (Parent), then press  $\odot$ .
- 3 Enter your four-digit password using the 0 - 9 buttons.

The Parent menu options appear.

- 4 Press  $\uparrow/\downarrow$  to select “Change Password,” then press  $\odot$ .
- 5 Enter a new four-digit password using the 0 - 9 buttons.
- 6 Enter the password set in step 5 again to confirm.
- 7 Press MENU to exit the menu screen.

#### Tip

If you have forgotten your password, enter the master password “4357” (corresponding to “HELP” on a phone number pad) in step 3. You can then store a new password.

#### Notes

- “4357” cannot be set as your password. If you entered “4357,” the message of “Password incorrect press  $\odot$  to try again” appears.
- When you select a Parental Control program and the indication is displayed on the screen, you cannot view that program even if you enter “4357” (see “To view blocked programs” on page 65).

## Selecting a Custom Rating

If you want to select the ratings to be blocked from “Custom” once you have activated the Parental Control feature (page 64), follow the procedure below.

For a detailed description of each rating, see “What the Ratings Mean” on page 68.

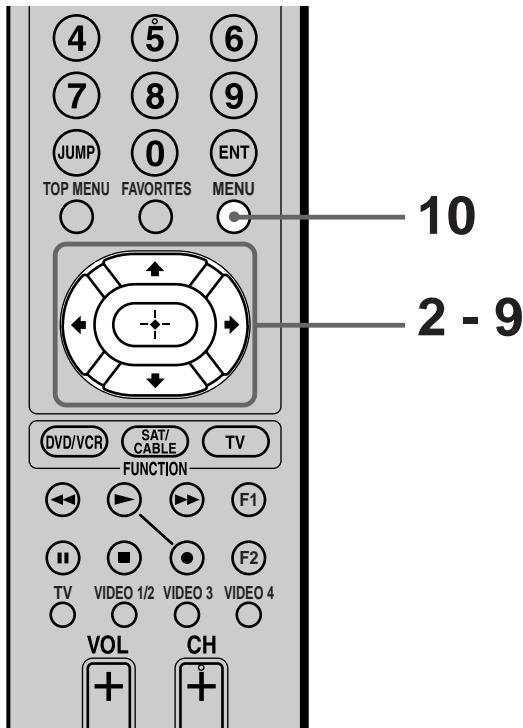

**1** Perform steps 1 to 7 in “Activating the Parental Control feature” on page 64 to display the Lock options.

**2** Press  $\uparrow/\downarrow$  to select “Custom,” then press  $\ominus$ .

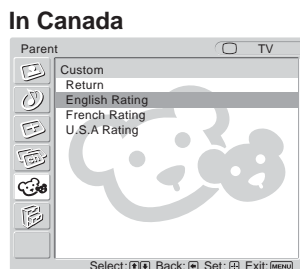
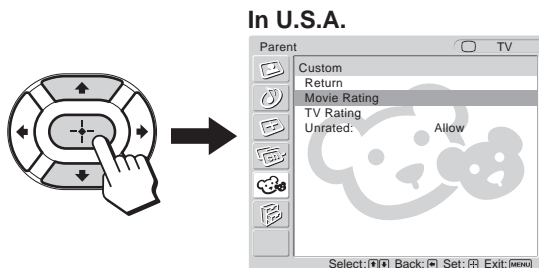

**3** Press  $\uparrow/\downarrow$  to select “Movie Rating,” then press  $\ominus$ .

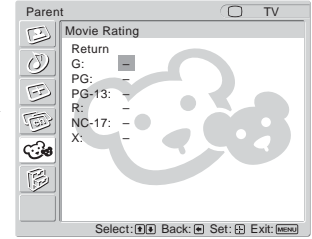
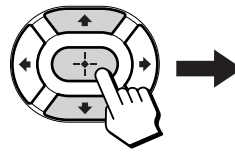

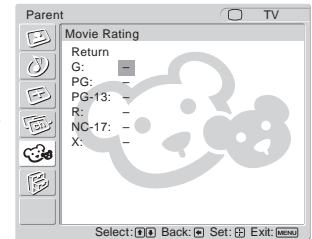
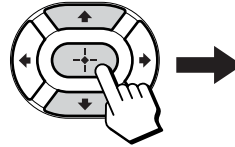

**4** Press  $\uparrow/\downarrow$  to select the rating to be blocked, then press  $\ominus$ .

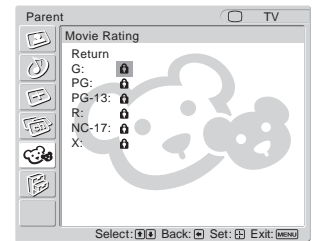

The  indication automatically appears beside the selected rating and all ratings below it, indicating that the programs that match the ratings will be blocked.



To unlock a rating, select , then press  $\ominus$ . The  indication changes into “-” and all ratings above it are unlocked.

**5** Press  $\leftarrow$  to return to the “Custom” menu.

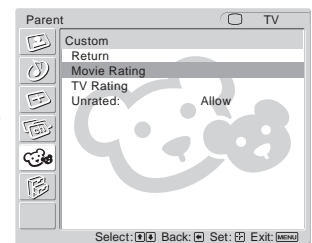
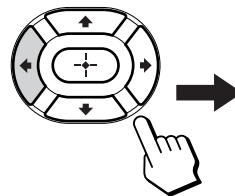

To select a rating in Canada, go to step 6.



- 6** To select a TV rating in U.S.A.:  
Press  $\uparrow/\downarrow$  to select “TV Rating,” then press  $\oplus$ .

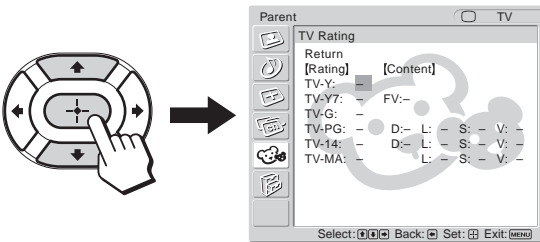

To select a TV rating in Canada:

- Press  $\uparrow/\downarrow$  to select “English Rating,” “French Rating,” or “U.S.A. Rating,” then press  $\oplus$ .

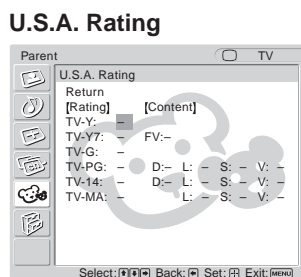
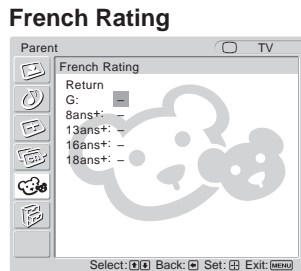
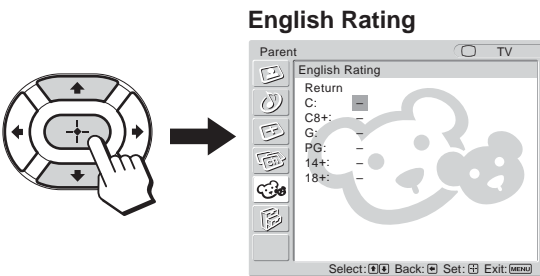

- 7** Press  $\uparrow/\downarrow$  to select the TV rating to be blocked, then press  $\oplus$ .

The  $\mathfrak{L}$  indication automatically appears beside the selected rating and all ratings below it, indicating that the programs that match the ratings will be blocked.

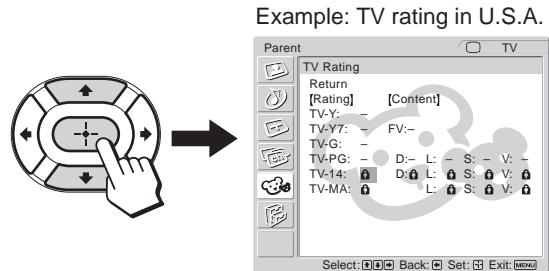

- To unlock a rating, select  $\mathfrak{L}$ , then press  $\oplus$ . The  $\mathfrak{L}$  indication changes into “-” and all ratings above it are unlocked.

Some U.S. TV ratings have additional content ratings called “extenders.”

The extenders are defined as follows:  
D (sexually suggestive Dialog), FV (Fantasy Violence), L (coarse Language), S (Sexual situations) and V (Violence).

By setting the extenders, you can define additional viewing limits.

For more details on extenders, see page 70.

All of the extenders included in the selected ratings will be blocked. If you want to allow any of them to be viewed, go to step 8. Otherwise, go to step 10.

- 8** Press  $\leftarrow/\rightarrow$  to select the extender to be viewed, then press  $\oplus$ .

“-” appears beside the selected extender, indicating that the programs that match the extender can be viewed.

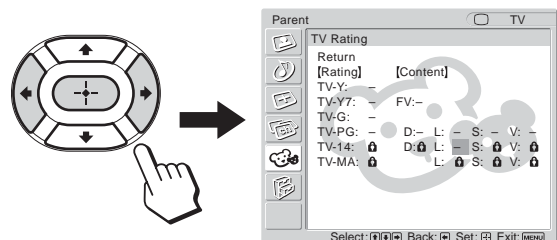

To relock the canceled extender, select  $\mathfrak{L}$ , then press  $\oplus$ .

The  $\mathfrak{L}$  indication appears to show that the programs that match the extender will be blocked again.

(Continued)

**9** Repeat step 8 for other extenders.

All programs that match the ratings you select and higher, except for the extenders that were canceled, will be blocked.

**10** Press MENU to exit the menu screen.

### To block programs or movies broadcast without a rating

Unrated option allows you to block programs or movies that are broadcast without a rating.

The unrated option is available only when you have selected U.S.A. as your country/region.

**1** Perform steps 1 and 2 of “Selecting a Custom Rating” on page 66.

**2** Press  $\uparrow/\downarrow$  to select “Unrated,” then press  $\oplus$ .

**3** Press  $\uparrow/\downarrow$  to select “Block,” then press  $\oplus$ .

Option	Description
Allow	Allows programs and movies that are broadcast without a rating.
Block	Blocks all programs and movies that are broadcast without a rating.

**4** Press MENU to exit the menu screen.

#### Note

If you choose to block unrated TV programs, be aware that the following types of programs may be blocked: programs broadcast from another country/region, emergency broadcasts, political programs, sports, news, public service announcements, religious programs, and weather.

## What the Ratings Mean

### Ratings in the U.S.A.

#### Sony’s predetermined ratings

These are original ratings that Sony has predetermined according to the viewer’s age. Each rating allows for viewing of certain programs, as follows:

Option	Description
Child	Suitable for children under the age of 7. Viewable U.S. movie ratings: G, NR, and N/A Viewable U.S. TV ratings: TV-Y, TV-G, and TV-NR
Youth	Suitable for children aged 7 and older. Viewable U.S. movie ratings: G, PG, NR, and N/A Viewable U.S. TV ratings: TV-Y, TV-Y7, TV-G, TV-PG, and TV-NR
Y.Adult (Young Adult)	Suitable for children aged 13 and older. Viewable U.S. movie ratings: G, PG, PG-13, NR, and N/A Viewable U.S. TV ratings: TV-Y, TV-Y7, TV-G, TV-PG, TV-14, and TV-NR

For descriptions of Child, Youth, and Y.Adult (Young Adult) ratings, see the following custom rating options.

## U.S. movie ratings

U.S. movie ratings are for movies (including those shown on TV) rated according to the Motion Picture Association of America (MPAA) Guidelines.

Option	Description
G (General Audiences — All Ages Admitted)	In G-rated films, no strong words are used, the violence is at a minimum, nudity and sex scenes are not present, nor is there any drug use.
PG (Parental Guidance Suggested — Some Material May Not Be Suitable For Children)	This is a film which may need to be monitored first by parents.
PG-13 (Parents Strongly Cautioned — Some Material May Be Inappropriate For Children Under 13)	Parents are alerted to be very careful about the attendance of their under-teenage children when viewing.
R (Restricted — Under 17 Requires Accompanying Parent Or Adult Guardian)	This film includes hard language, tough violence, nudity, drug abuse or other elements of concern.
NC-17 or X (No One 17 And Under Admitted)	This is a film that most parents would consider not suitable for children aged 17 and under. There may be violence, sex, abhorrent behavior, drug abuse or other elements of concern.

## U.S. TV ratings

U.S. TV ratings are for TV programs rated according to the U.S. Television Parental Guidelines.

Option	Description
TV-Y (All Children)	This program is designed for young children aged 2 - 6 and is appropriate for all children.
TV-Y7 (Directed to Older Children)	This program is designed for children aged 7 and older. Themes and elements in this program may include mild fantasy violence or slapstick violence, or may frighten children under the age of 7.
TV-G (General Audience)	Most parents would find this program suitable for all ages. It contains little or no violence, no strong language and little or no sexual dialog or situations.
TV-PG (Parental Guidance Suggested)	This program contains some material that parents may find unsuitable for younger children.
TV-14 (Parents Strongly Cautioned)	This program contains some material that many parents would find unsuitable for children under the age of 14.
TV-MA (Mature Audience Only)	This program is specifically designed to be viewed by adults and therefore may be unsuitable for children under the age of 17.

(Continued)

## About the extenders of U.S. TV ratings

TV-Y7, TV-PG, TV-14 and TV-MA ratings have additional content ratings called “extenders” to define additional viewing limits. The extenders are defined as follows:

Option	Description
FV (Fantasy Violence)	Programs containing cartoon violence occurring in TV-Y7 programs only.
D (sexually suggestive Dialog)	Programs containing suggestive dialog, or sexual innuendo.
L (coarse Language)	Programs containing coarse language.
S (Sexual situations)	Programs containing sexual content.
V (Violence)	Programs containing violence. There may be some profanity, violence or brief nudity in these programs.

---

## Ratings in Canada

### Sony's predetermined ratings

These are original ratings that Sony has predetermined according to the viewer's age. Each rating allows you to view the certain programs, as follows:

Option	Description
Child	Suitable for children under the age of 8. Viewable Canadian English Language ratings: C and G Viewable Canadian French Language ratings: G Viewable U.S. TV ratings: TV-Y, TV-G, and TV-NR
Youth	Suitable for children aged 8 and older. Viewable Canadian English Language ratings: C, G, C8+, and PG Viewable Canadian French Language ratings: G and 8 ans+ Viewable U.S. TV ratings: TV-Y, TV-Y7, TV-G, TV-PG, and TV-NR
Y.Adult (Young Adult)	Suitable for children aged 14 and older. Viewable Canadian English Language ratings: C, G, C8+, PG, and 14+ Viewable Canadian French Language ratings: G, 8 ans+, and 13 ans+ Viewable U.S. TV ratings: TV-Y, TV-Y7, TV-G, TV-PG, TV-14, and TV-NR

For descriptions of Child, Youth, and Y.Adult (Young Adult) ratings, see the following custom rating options.

## Canadian English Language ratings

The Canadian English Language ratings are for TV programs in English broadcast in Canada.

Option	Description
C (Programming intended for children under the age of 8)	There will be no realistic scenes of violence or no offensive language, nudity or sexual content. Careful attention is paid to themes, which could threaten children's sense of security and well-being.
C8+ (Programming generally considered acceptable for children aged 8 and older to watch on their own)	Violence will not be portrayed as the preferred, acceptable, or only way to resolve conflict; or children will not be encouraged to imitate dangerous acts which they may see on television. There will be no profanity, nudity or sexual content.
G (General Audience)	Will contain very little violence, either physical or verbal or emotional. There may be some inoffensive slang, no profanity and no nudity.
PG (Parental Guidance)	Programming intended for a general audience but which may not be suitable for younger children. Parents may consider some content inappropriate for unsupervised viewing by children aged 8 - 13.
14+ (Programming contains themes or content which may not be suitable for viewers under the age of 14)	Parents are strongly cautioned to exercise discretion in permitting viewing by pre-teens and early teens.
18+ (Adult)	May contain violence integral to the development of the plot, character or theme, intended for adult audiences. May contain graphic language and explicit portrayals of nudity and/or sex.

## Canadian French Language ratings

The Canadian French Language ratings are for TV programs in French broadcast in Canada.

Option	Description
G (General)	Programming intended for audience of all ages. Contains no violence, or the violence it contains is minimal or is depicted appropriately with humor or caricature or in an unrealistic manner.
8 ans+ (8+ General — Not recommended for young children)	Programming intended for a broad audience but contains light or occasional violence that could disturb young children. Viewing with an adult is recommended for young children (under the age of 8).
13 ans+ (Programming may not suitable for children under the age of 13)	Viewing with an adult is strongly recommended for children under the age of 13.
16 ans+ (Programming is not suitable for children under the age of 16)	Contains frequent scenes of violence or intense violence.
18 ans+ (Programming restricted to adults)	Contains constant violence or scenes of extreme violence.

# Turning Off the TV Automatically

You can set the TV to turn off automatically after a predetermined period of time (15, 30, 45, 60, or 90 minutes).

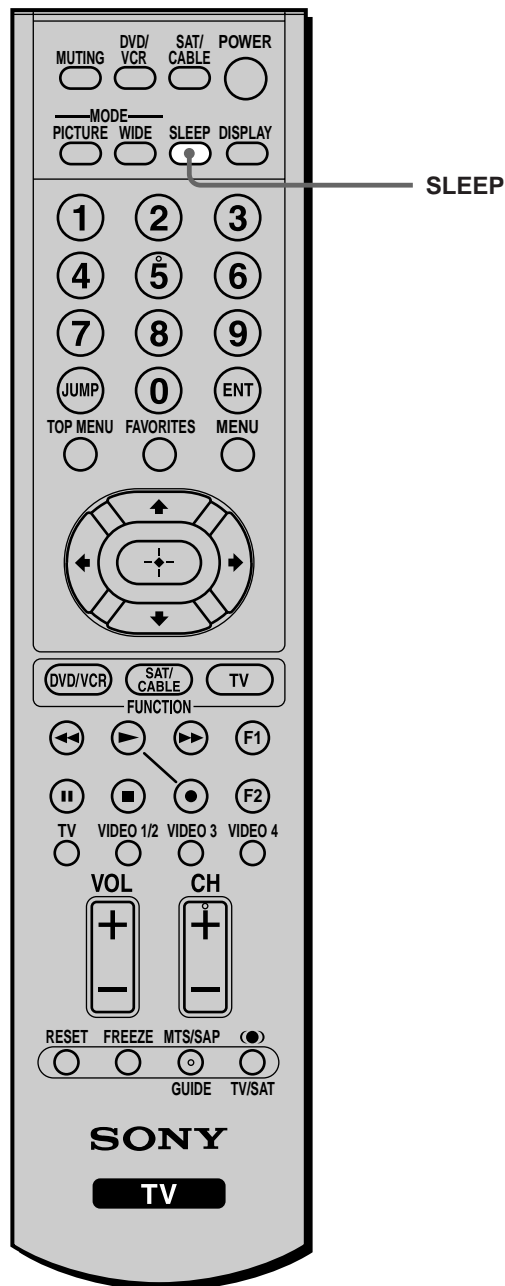

Press SLEEP repeatedly until the desired period of time appears.

Each time you press the button, the period of time changes as follows:

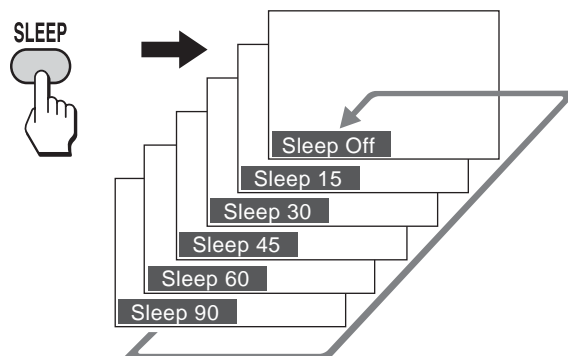

While the Sleep timer is activated, the ⏰ (Timer) LED on the TV lights up in red.

## To cancel the Sleep timer

Press SLEEP repeatedly until “Sleep Off” appears.

### Tips

- If you turn the TV off, and then turn it on again, the Sleep timer returns to “Sleep Off.”
- “TV will turn off soon” appears one minute before the TV shuts off. This message may not appear if you perform any operation with the menu opened.

# Additional Information

## Troubleshooting

### Self-diagnosis function

The TV is equipped with a self-diagnosis function. If there is a problem with your TV, the  (Power on/Stand by) LED on the front panel will flash repeatedly in red. Writing down the duration of flashes and interval between flashes helps you inform qualified Sony personnel of the TV's condition.

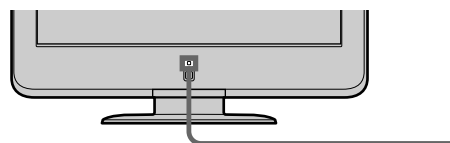



 (Power on/Stand by) LED (flashing in red)

- 1 Measure how long the  (Power on/Stand by) LED flashes and stops flashing.







For example, the LED flashes for 2 seconds, stops flashing for 1 second, and flashes for 2 seconds.

- 2 Press  (Power) on the TV to turn it off, and disconnect the power cord, then inform qualified Sony personnel or the Direct Response Center/ Customer Relations Center of how the indicator flashes (duration and interval).

### Trouble symptoms and remedies

Problem	Possible remedies
<b>No picture.</b> Cannot receive any channels.	<ul style="list-style-type: none"> <li>• Make sure the power cord is connected securely.</li> <li>• Turn on the power of the TV.</li> <li>• Check antenna/cable connections.</li> </ul>
Cannot receive upper channels (UHF) when using an antenna.	<ul style="list-style-type: none"> <li>• Set "Cable" to "Off" in the  (Channel) menu (page 37).</li> <li>• Perform Auto Program to add receivable channels that are not presently in the TV's memory (page 36).</li> </ul>
TV is locked to one channel.	<ul style="list-style-type: none"> <li>• Perform Auto Program to add receivable channels that are not presently in the TV's memory (page 36).</li> <li>• Check your Channel Fix setting (page 38).</li> </ul>
Cannot receive any channels when using cable TV.	<ul style="list-style-type: none"> <li>• Perform Auto Program to add receivable channels that are not presently in the TV's memory (page 36).</li> <li>• Make sure "Cable" in the  (Channel) menu is set to "On" (page 37).</li> </ul>
Cannot receive or select channels.	<ul style="list-style-type: none"> <li>• Perform Auto Program to add receivable channels that are not presently in the TV's memory (page 36).</li> </ul>
The TV turns off automatically. (The TV enters the standby mode.)	<ul style="list-style-type: none"> <li>• Check if the Sleep timer is activated (page 72).</li> </ul>
No picture from some video sources.	<ul style="list-style-type: none"> <li>• Check the connection between the optional video equipment and the TV.</li> <li>• Press the Input Select buttons on the remote control (page 50).</li> <li>• When you connect video equipment to both the VIDEO and the S VIDEO input jacks, make sure "Auto YC" in the  (Setup) menu is set to "On" to view the S VIDEO input (page 26).</li> </ul>

(Continued)

<b>Problem</b>	<b>Possible remedies</b>
<b>Poor picture.</b>	
Double images or ghosts.	<ul style="list-style-type: none"> <li>• Check antenna/cable connections.</li> <li>• Check the antenna location and direction.</li> </ul>
Only snow and noise appear on the screen.	<ul style="list-style-type: none"> <li>• Check if the antenna is broken or bent.</li> <li>• Check if the antenna has reached the end of its serviceable life. (3-5 years in normal use, 1-2 years at the seaside.)</li> </ul>
Dotted lines or stripes.	<ul style="list-style-type: none"> <li>• Keep the TV away from noise sources such as cars, motorcycles, or hair-dryers.</li> </ul>
No color./Dark picture./Color is not correct.	<ul style="list-style-type: none"> <li>• Press PICTURE to select the desired Picture Mode (page 43).</li> <li>• Adjust the Picture Mode options in the  (Video) menu (page 57).</li> </ul>
The picture is too bright.	<ul style="list-style-type: none"> <li>• Press PICTURE to select the desired Picture Mode (page 43).</li> </ul>
Picture (stripe) noise.	<ul style="list-style-type: none"> <li>• Make sure that the antenna is connected using the supplied 75-ohm coaxial cable.</li> <li>• Keep the antenna cable away from other connecting cords.</li> <li>• Do not use 300-ohm twin lead cables as interference may occur.</li> </ul>
<b>No sound./Noisy sound.</b>	
Good picture, no sound.	<ul style="list-style-type: none"> <li>• Check the volume control.</li> <li>• Press MUTING or VOL + so that “Muting” disappears from the screen (page 41).</li> <li>• Disconnect your headphones.</li> <li>• Set “Speaker” to “On” in the  (Audio) menu (page 61). If it is set to “Off,” sound is not output from the TV’s speakers regardless of the TV’s volume control.</li> </ul>
Audio noise.	<ul style="list-style-type: none"> <li>• Make sure that the antenna is connected using the supplied 75-ohm coaxial cable.</li> <li>• Keep the antenna cable away from other connecting cords.</li> <li>• Do not use 300-ohm twin lead cables as interference may occur.</li> <li>• Press MTS/SAP to select “Mono” (page 60).</li> </ul>
<b>Striped noise during playback/recording of a VCR.</b>	<ul style="list-style-type: none"> <li>• This is caused by video head interference. Keep your VCR away from the TV.</li> <li>• Leave a space of 30 cm (11 7/8 inches) between your VCR and the TV to avoid noise.</li> <li>• Avoid installing your VCR in front of the TV or at the side of the TV.</li> </ul>
<b>Cannot operate menu item.</b>	<ul style="list-style-type: none"> <li>• If the option you want to select appears in a pale color, you cannot select it.</li> </ul>
<b>Wide Screen Mode changes automatically.</b>	<ul style="list-style-type: none"> <li>• The current Wide Screen Mode setting is automatically replaced with the 4:3 Default setting when you change the channel or video input, if “4:3 Default” in the  (Screen) menu is set to other than “Off.” If you want to lock in the Wide Screen Mode selected with the WIDE button, set “4:3 Default” to “Off” in the  (Screen) menu (page 48).</li> </ul>
<b>Remote control does not operate.</b>	<ul style="list-style-type: none"> <li>• The batteries could be weak. Replace the batteries.</li> <li>• Check the polarity of the batteries.</li> <li>• If the  (Power on/Stand by) LED on the TV does not light in red, press  (Power) on the TV.</li> <li>• Press the TV button first for TV operation.</li> <li>• Point the remote control at the remote control sensor of the TV.</li> <li>• Install the TV away from fluorescent lights.</li> <li>• Try to press F1 or F2 button on the remote control.</li> </ul>
<b>Cannot change channels with the remote control.</b>	<ul style="list-style-type: none"> <li>• If you are using another device to change channels, be sure you have not inadvertently switched your TV from channel 3 or 4 setting. Use the Channel Fix option to “fix” the channel based on the type of hookup (see “To fix in a TV channel” on page 38).</li> <li>• If you are using another device to control channels, be sure the FUNCTION button for that device has been pressed. For example, if you are using your cable box to control channels, be sure to press SAT/CABLE (page 18).</li> </ul>
<b>Lost password.</b>	<ul style="list-style-type: none"> <li>• Select the  (Parent) menu on the menu screen, then enter the following master password: 4357. The master password clears your previous password and allows you to enter a new password (page 65).</li> </ul>



# Specifications

**Television system:**

American TV standard

**Channel coverage:**

VHF: 2-13/UHF: 14-69/CATV: 1-125

**Antenna:**

75-ohm external terminal for VHF/UHF

**Screen size (measured diagonally):**

23 inches

**Panel System:**

LCD (Liquid Crystal Display) Panel

**Display resolution:**

1,366 dots (horizontal) × 768 lines (vertical)

**VIDEO 1/2 IN:**

S VIDEO (4-pin mini DIN):

Y: 1.0 Vp-p, 75 ohms unbalanced,  
sync negative

C: 0.286 Vp-p (Burst signal),  
75 ohms

VIDEO: 1 Vp-p, 75 ohms unbalanced,  
sync negative

AUDIO: 500 mVrms (100% modulation)  
Impedance: 47 kilohms

**HD/DVD 3 IN:**

Y, P<sub>B</sub>, P<sub>R</sub> (Component Video):

Y: 1.0 Vp-p, 75 ohms  
unbalanced, sync negative

P<sub>B</sub>: 0.7 Vp-p, 75 ohms

P<sub>R</sub>: 0.7 Vp-p, 75 ohms

Signal format:  
480i, 480p, 720p, 1080i

AUDIO: 500 mVrms (100% modulation)  
Impedance: 47 kilohms

**HDMI 4 IN:**

HDMI: Video: 480i, 480p, 720p, 1080i  
Audio: Two channel linear PCM  
32, 44.1 and 48 kHz, 16, 20 and  
24 bits

AUDIO: 500 mVrms (100% modulation)  
Impedance: 47 kilohms

**AUDIO OUT:**

500 mVrms (100% modulation)

More than 1 Vrms at the maximum volume setting  
(Variable)

More than 500 mVrms (Fixed)

**Headphones:**

Stereo mini jack

Impedance: 16 ohms

**Speaker:**

Woofer: ø70 mm (2)

Tweeter: ø28 mm (2)

**Speaker output:**

4 W + 4 W

**Power requirement:**

120 V AC, 60 Hz

**Power consumption:**

In use: 95 W

In standby: Less than 1 W

**Dimensions (W/H/D):**

Including TV stand: 605 × 525 × 242 mm  
(approx.) (23 <sup>7</sup>/<sub>8</sub> × 20 <sup>3</sup>/<sub>4</sub> × 9 <sup>5</sup>/<sub>8</sub> inches)

Without TV stand: 605 × 475 × 102 mm  
(approx.) (23 <sup>7</sup>/<sub>8</sub> × 18 <sup>3</sup>/<sub>4</sub> × 4 <sup>1</sup>/<sub>4</sub> inches)

**Mass:**

Including TV stand: 11.6 kg (25 lb. 9 <sup>1</sup>/<sub>8</sub> oz.)

Without TV stand: 10.0 kg (22 lb. <sup>3</sup>/<sub>4</sub> oz.)

**Supplied accessories:**

Remote control RM-Y1109 (1)

Size AA batteries (2)

75-ohm coaxial cable (1)

AC power cord (1)

Operating Instructions (1)

Quick Setup Guide (1)

Warranty Card (1)

**Optional accessories:**

Headphones plug adaptor

Connecting cables

Wall-Mount Bracket SU-W210

**Note**

Some optional accessories may be out of stock.

Design and specifications are subject to change  
without notice.

# Index

4:3 Default ..... 48

## A

### Adjusting

- picture position ..... 55, 56
- picture quality ..... 57
- sound quality ..... 59
- volume ..... 41

Audio Out ..... 29, 63

Auto Program ..... 36

Auto SAP ..... 60

Auto YC ..... 26

## B

Backlight ..... 58

## C

Cable TV ..... 36

Channel setting ..... 36

Channel Fix ..... 38

Channel Label ..... 53

Channel Skip/Add ..... 37

Closed caption ..... 42

Component Video connectors .... 30, 32, 33

Connecting ..... 24

antenna ..... 24

AV receiver ..... 29

cable box ..... 24

digital cable box ..... 32

digital satellite receiver ..... 33, 34

DVD player ..... 30, 31

power cord ..... 25

satellite receiver ..... 27, 28

VCR ..... 26

## D

DISPLAY ..... 41

## E

Effect ..... 44

## F

Favorite channels ..... 52

Front and rear connectors ..... 20

Full ..... 46

## H

H Center ..... 56

## I

Input select ..... 50

## J

JUMP ..... 41

## L

Language selection ..... 39

## M

Menu ..... 38

Mild Mode ..... 58

Mono ..... 60

MTS/SAP ..... 60

MUTING ..... 41

## N

Noise Reduction ..... 58

Normal ..... 46

## P

Parent ..... 63

password ..... 64, 65

ratings ..... 66

Picture Mode ..... 43

Power on/off ..... 41

Pro ..... 43

## R

Remote control ..... 13

battery installation ..... 13

programming ..... 16

using with other equipment ..... 18

## S

S Video input jack ..... 26

Self-diagnosis function ..... 73

Sleep timer ..... 72

Speaker ..... 29, 62

Specifications ..... 75

SRS WOW ..... 44

Standard ..... 43

Stereo ..... 60

## T

Troubleshooting ..... 73

## U

Unpacking ..... 13

## V

V Center ..... 55

VHF/UHF channels ..... 37

Video label ..... 51

Vivid ..... 43

Volume ..... 41

## W

Wide Screen Mode ..... 45

Wide Mode ..... 48

Wide Zoom ..... 46

## Z

Zoom ..... 46







<http://www.sony.net/>



Printed on 100% recycled paper.

Printed in Japan



2176244120