







# MODEL H8220 1/2" EXTENDED ANVIL IMPACT WRENCH INSTRUCTION SHEET

<b>⚠ WARNING</b>	
	<b>EYE/EAR INJURY HAZARD!</b> Wear safety glasses and hearing protection when using this tool!
	<b>INJURY HAZARD!</b> Always disconnect tool from air to prevent unexpected operation during service!
	<b>DO NOT EXCEED 120 PSI!</b> Personal injury could occur.
	<b>SHATTERING HAZARD!</b> Use sockets rated for impact wrench use only.

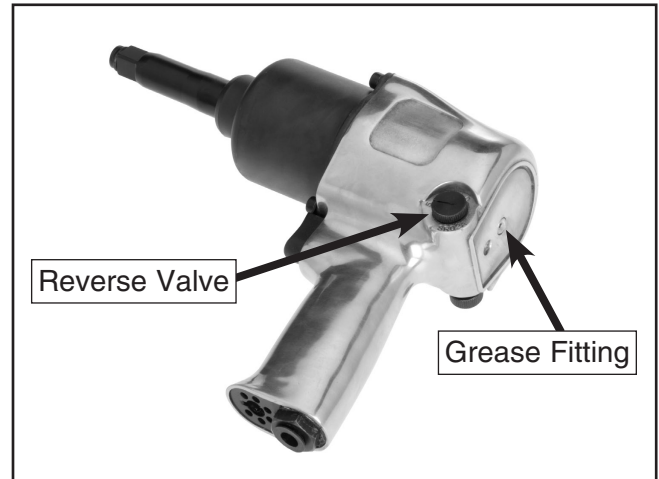

**Figure 1.** Model H8220

## Specifications

Drive Size.....	1/2"
No-Load Speed.....	7,500 RPM
Maximum Torque.....	420 ft/lb
Air Inlet Size.....	1/4" NPT
Air Consumption.....	5 CFM
Operating Pressure.....	90 PSI
Weight.....	6 lbs

## Inventory

- A. 1/2" Extended Anvil Impact Wrench..... 1
- B. 1/4" NPT Air Fitting..... 1
- C. Oil..... 1

## Operation

Install any 1/2" drive socket into your air impact wrench. Push the reverse valve, shown in **Figure 1**, in or out to change direction. Turn the valve knob from 1 to 6 to adjust air flow. Connect to air line regulated at 90 PSI.

Insert one shot of grease into the grease fitting shown in **Figure 1**, every three months. The impact wrench **MUST** be regularly lubricated with 3-4 drops of air tool oil directly into the air fitting before each use. For best results, we recommend using an in line filter, lubricator, and regulator, as shown in **Figure 2**.

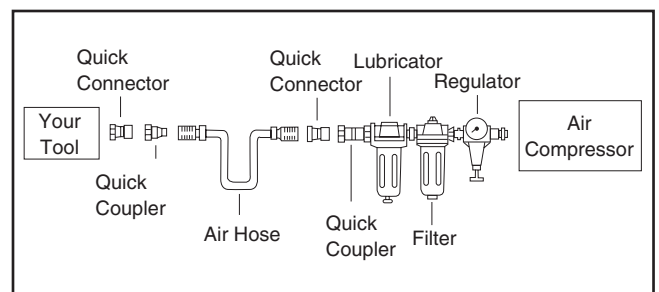

**Figure 2.** Installing your tool.

*If you need help with your new pneumatic tool, call our Tech Support at: (570) 546-9663.*

COPYRIGHT © AUGUST, 2007 BY GRIZZLY INDUSTRIAL, INC.

**WARNING: NO PORTION OF THIS MANUAL MAY BE REPRODUCED IN ANY SHAPE OR FORM WITHOUT THE WRITTEN APPROVAL OF GRIZZLY INDUSTRIAL, INC.**

#JM9743 PRINTED IN CHINA

# H8220 Parts Breakdown and List

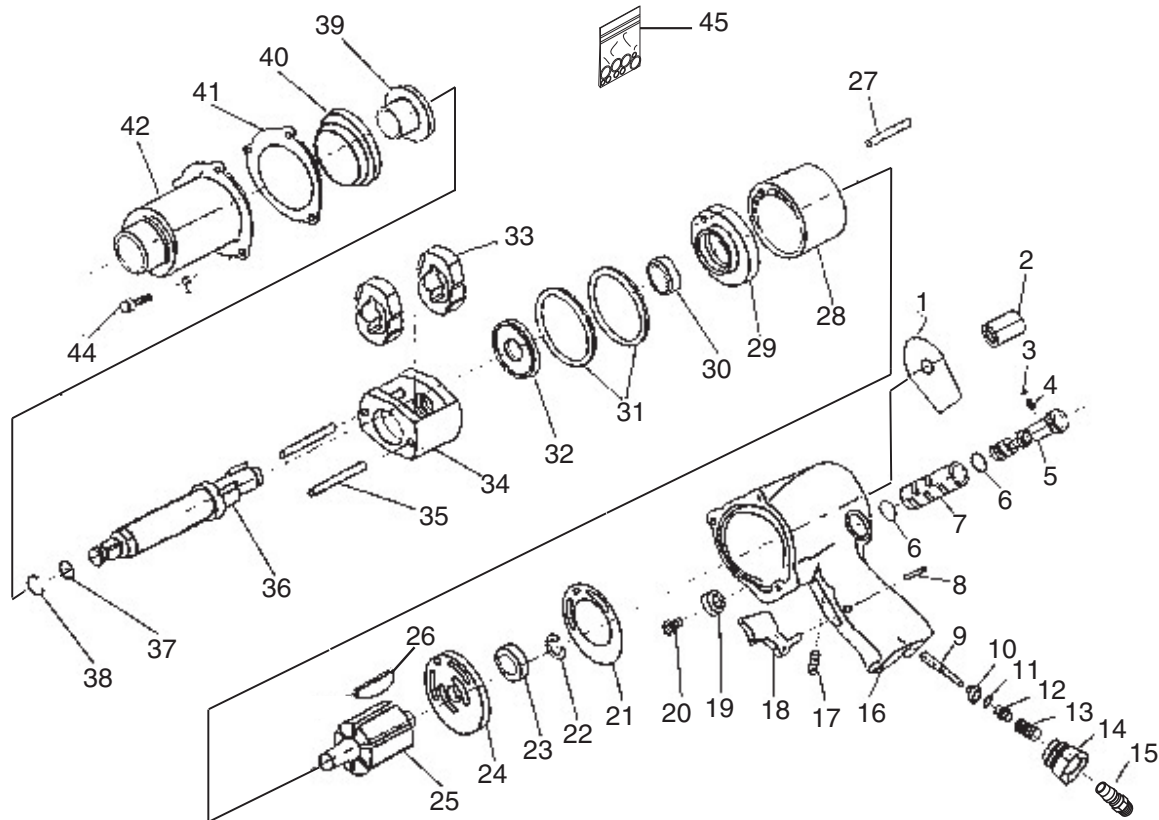

REF PART #	DESCRIPTION
1	PH8220001 NAMEPLATE
2	PH8220002 FLUSH TYPE GREASE FITTING
3	PH8220003 DETENT BALL
4	PH8220004 DETENT SPRING
5	PH8220005 REVERSE VALVE
6	PH8220006 VALVE O-RING 10.6 X 1.8
7	PH8220007 REVERSE VALVE BUSHING
8	PH8220008 TRIGGER PIN 4 X 19
9	PH8220009 VALVE STEM
10	PH8220010 VALVE RING
11	PH8220011 VALVE O-RING 7.1 X 1.8
12	PH8220012 THROTTLE VALVE BUSHING
13	PH8220013 VALVE SPRING
14	PH8220014 AIR STRAINER
15	PH8220015 1/4" NPT MALE AIR FITTING
16	PH8220016 HOUSING ASSEMBLY
17	PSS20M SET SCREW M8-1.25 X 8
18	PH8220018 TRIGGER
19	PH8220019 REVERSE VALVE KNOB
20	PH8220020 TAPERED SCREW M6-1 X 10
21	PH8220021 GASKET
22	PR45M INT RETAINING RING 10MM

REF PART #	DESCRIPTION
23	PH8220023 FRONT ROTOR BEARING R8
24	PH8220024 REAR END PLATE
25	PH8220025 ROTOR
26	PH8220026 ROTOR BLADE
27	PH8220027 CYLINDER DOWEL 4 X 58
28	PH8220028 CYLINDER
29	PH8220029 FRONT END PLATE
30	P6001 BALL BEARING 6001ZZ
31	PH8220031 MOTOR CLAMP WASHER
32	PH8220032 REAR WASHER
33	PH8220033 HAMMER
34	PH8220034 HAMMER FRAME
35	PH8220035 HAMMER PIN
36	PH8220036 ANVIL
37	PH8220037 RETAINER O-RING 7.5 X 1.8
38	PH8220038 SOCKET RETAINER
39	PH8220039 HAMMER CASE BUSHING
40	PH8220040 HAMMER CASE PILOT
41	PH8220041 HAMMER CASE GASKET
42	PH8220042 HAMMER CASE
44	PSB15M CAP SCREW M5-.8 X 20
45	PH8220045 O-RING KIT