

## Operating Instructions

### Single Conveyor Unit SSE-2

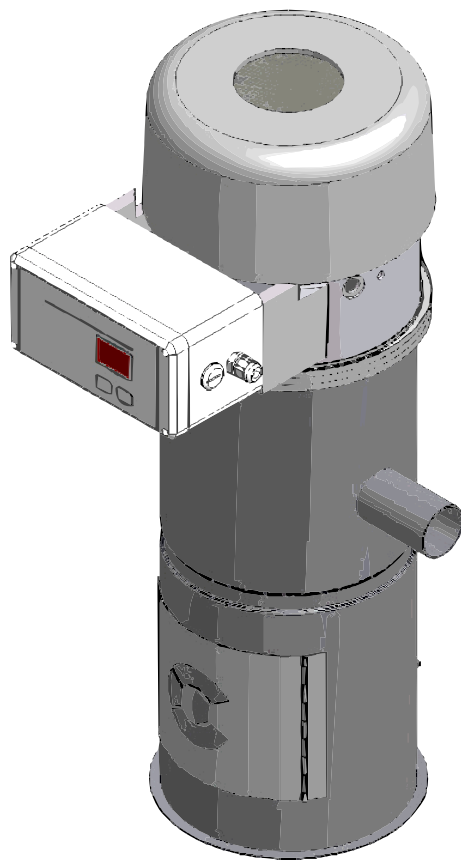

SM4-615

**Sterling Material Processing**  
5200 West Clinton Ave.

Milwaukee, WI 53223

Telephone: (414) 354-0970

Fax: (414) 354-6421

www.sterlco.com

**Technical service:**

Service department

Telephone: **(800) 423-3183**

**Edition: 07/02**

**Confirmation number:** \_\_\_\_\_

These operating instructions are for:\*

(\* Please fill in personally)

Serial number: \_\_\_\_\_

Built in: \_\_\_\_\_

Date of delivery: \_\_\_\_\_

Number of delivery: \_\_\_\_\_

Date of commissioning: \_\_\_\_\_

Location: \_\_\_\_\_

Group of machines: \_\_\_\_\_

Sterling Material Processing retains all rights to change the information in these operating instructions at any time without notice.

We assume no liability for any errors or direct or indirect damage resulting in context with these operating instructions.

Copying, translation or publication in any form except for personal use of purchaser requires approval from Sterling Material Processing.

All rights reserved.

## Please note that our address and phone information has changed. Please reference this page for updated contact information.



These manuals are obsolete and are provided only for their technical information, data and capacities. Portions of these manuals detailing procedures or precautions in the operation, inspection, maintenance and repair of the products may be inadequate, inaccurate, and/or incomplete and shouldn't be relied upon. Please contact the ACS Group for more current information about these manuals and their warnings and precautions.

### Parts and Service Department

The ACS Customer Service Group will provide your company with genuine OEM quality parts manufactured to engineering design specifications, which will maximize your equipment's performance and efficiency. To assist in expediting your phone or fax order, please have the model and serial number of your unit when you contact us. A customer replacement parts list is included in this manual for your convenience. ACS welcomes inquiries on all your parts needs and is dedicated to providing excellent customer service.

#### For immediate assistance, please contact:

- North, Central and South America, 8am – 5pm CST +1 (800) 483-3919 for drying, conveying, heating and cooling and automation. For size reduction: +1 (800) 229-2919.  
North America, emergencies after 5pm CST (847) 439-5855  
**North America email: [acsuscanadacustserv@corpemail.com](mailto:acsuscanadacustserv@corpemail.com)**
- Mexico, Central & South America  
**Email: [acslatinamericacustserv@corpemail.com](mailto:acslatinamericacustserv@corpemail.com)**
- Europe, Middle East & Africa +48 22 390 9720  
**Email: [acseuropecustserv@corpemail.com](mailto:acseuropecustserv@corpemail.com)**
- India +91 21 35329112  
**Email: [acsindiacustserv@corpemail.com](mailto:acsindiacustserv@corpemail.com)**
- Asia/Australia +86 512 8717 1919  
**Email: [acsasiacustserv@corpemail.com](mailto:acsasiacustserv@corpemail.com)**

### Sales and Contracting Department

Our products are sold by a worldwide network of independent sales representatives. Contact our Sales Department for the name of the sales representative nearest you.

Let us install your system. The Contract Department offers any or all of these services: project planning; system packages including drawings; equipment, labor, and construction materials; and union or non-union installations.

#### For assistance with your sales or system contracting needs please Call:

North, Central and South America +1 (262) 641-8600 or +1 (847) 273-7700 Monday–Friday, 8am–5pm CST

Europe/Middle East/Africa +48 22 390 9720

India +91 21 35329112

Asia/Australia +86 512 8717 1919

#### Facilities:

ACS offers facilities around the world to service you no matter where you are located. For more information, please visit us at [www.acscorporate.com](http://www.acscorporate.com)

United States:

#### ACS Schaumburg – Corporate Offices

1100 E. Woodfield Road  
Suite 588  
Schaumburg, IL 60173  
Phone: + 1 847 273 7700  
Fax: + 1 847 273 7804

#### ACS New Berlin – Manufacturing Facility

2900 S. 160<sup>th</sup> Street  
New Berlin, WI 53151  
Phone : +1 262 641 8600  
Fax: + 1 262 641 8653

Asia/Australia:

#### ACS Suzhou

109 Xingpu Road SIP  
Suzhou, China 215126  
Phone: + 86 8717 1919  
Fax: +86 512 8717 1916

Europe/Middle East/Africa:

#### ACS Warsaw

Ul. Działkowa 115  
02-234 Warszawa  
Phone: + 48 22 390 9720  
Fax: +48 22 390 9724

India

#### ACS India

Gat No. 191/1, Sandbhor Complex  
Mhalunge, Chakan, Tal Khed,  
Dist. Pune 410501, India  
Phone: +91 21 35329112  
Fax: + 91 20 40147576

---

## Table of contents

<b>1. General instructions</b> .....	<b>1-1</b>
1.1. Warnings and symbols .....	1-2
1.2. Explanations and information .....	1-3
1.3. Legal basis .....	1-3
1.4. Fields of applications .....	1-3
1.5. Notes on usage .....	1-3
<b>2. Safety instructions</b> .....	<b>2-1</b>
2.1. For your safety .....	2-2
2.2. For the operating safety of the equipment .....	2-5
<b>3. Putting into operation</b> .....	<b>3-1</b>
3.1. Checking the pipe system .....	3-2
3.2. Adjusting the suction pipes .....	3-3
3.3. Setting the controller .....	3-4
3.4. Initial conveying operations .....	3-5
3.5. Switching off the unit .....	3-5
<b>4. Error and error correction</b> .....	<b>4-1</b>
<b>5. Maintenance</b> .....	<b>5-1</b>
5.1. Maintenance intervals .....	5-3
5.2. Servicing the conveyor .....	5-3
5.2.1. Changing the sealing ring of the outlet flap .....	5-4
5.2.2. Adjusting the flap switch .....	5-5
5.2.3. Cleaning the unit .....	5-6
5.3. Replacing carbon brushes at turbine .....	5-8
<b>6. Functional description</b> .....	<b>6-1</b>
6.1. General .....	6-2
6.2. Controller .....	6-3
<b>7. Transport, Assembly and Storage</b> .....	<b>7-1</b>
7.1. Transport and Packing .....	7-2
7.2. Assembly .....	7-2
7.3. Storage .....	7-2

<b>8. Assembly instructions</b> .....	<b>8-1</b>
8.1. Assembly .....	8-2
8.2. Mounting on the processing machine .....	8-4
8.3. Mounting onto a machine hopper .....	8-4
8.4. Mounting onto mixing hoppers with lateral inlet .....	8-5
8.5. Mounting onto dosing station DT 30 .....	8-5
8.6. Material feed .....	8-6
8.7. Mounting the suction pipe MV .....	8-6
8.8. Pipework .....	8-7
8.9. Electrical connection .....	8-7
8.9.1. Installation of the "flap switch" signal line .....	8-8
8.9.2. Installation of the signal line of the SKW (optional) .....	8-8
8.9.3. Installation of the alarm indicating device (optional) .....	8-9
8.10. Compressed-air supply (only SSE-2 with active cleaning) .....	8-10
8.11. Installing the accessories .....	8-10
<b>9. Technical data</b> .....	<b>9-1</b>
<b>10. Spare parts list</b> .....	<b>10-1</b>
10.1. SSE-2, 230 V, 50 Hz .....	10-3
10.2. SSE-2, 110 V, 60 Hz .....	10-4
10.3. SSE-2, 230 V, 50 Hz with active cleaning .....	10-5
10.4. SSE-2, 110 V, 60 Hz with active cleaning .....	10-5
10.5. Accessories .....	10-6
<b>11. Accessories</b> .....	<b>11-1</b>
<input type="checkbox"/> -----	
<input type="checkbox"/> -----	
<input type="checkbox"/> -----	
<b>12. Electrical manual</b> .....	<b>12-1</b>
<input type="checkbox"/> Connection diagram no.: -----	
<input type="checkbox"/> Currently not available; will be delivered at a later date !	

## 1. General instructions



These instructions apply to all persons within the range of action of the equipment.

These operating instructions are to be used by all persons assigned activities connected with the equipment.

## 1.1. Warnings and symbols

The following warnings and symbols are used in these operating instructions:



This symbol indicates danger to life! Fatal or serious injury is possible if the corresponding instructions, regulations or warnings are not observed.



This symbol indicates that serious injury is possible if the corresponding instructions, regulations or warnings are not observed.



This symbol indicates that extensive damage to equipment is possible if the corresponding instructions, regulations or warnings are not observed.



This symbol indicates information important for becoming familiar with the equipment, i.e. technical correlations.



This symbol indicates that a technical term is explained at this point.



## **1.2. Explanations and information**

Various terms and designations are used in these operating instructions to ensure clarity. Therefore please note that the terms used in the text stand for the corresponding explanations listed below.

- **Equipment**  
"Equipment" can mean an individual unit, a machine or an installation.
- **Operating personnel**  
The "operating personnel" are persons operating the equipment on their own responsibility or according to instructions.
- **Operator**  
The "operator" of the equipment (production manager, foreman, etc.) is the person responsible for all production sequences. The operator instructs the operating personnel of what is to be done.
- **Operating instructions**  
The "operating instructions" describe the interaction of the equipment, production sequences or methods. The operating instructions must be compiled by the operator of the equipment.
- **Equipment foreman**  
When several operating personnel work on one machine, the "equipment foreman" coordinates the sequences. The equipment foreman must be appointed by the operator.
- **Trained personnel**  
"Trained personnel" are persons who, due to their training, are authorized to carry out the required work.

## **1.3. Legal basis**

See "Manufacturer's Certificate" resp. "Certificate of Conformity".

## **1.4. Fields of applications**

Sterling single conveying units are designed for use in facilities in which require independent machine conveying systems. The single conveying units have been developed for conveying thermoplastic granules. A typical area of application is for processing machines and drying hoppers with throughputs of up to 180 kg/h (396 lbs/hr).

## **1.5. Notes on usage**

- Experienced operators can begin directly with the chapter on "Start-up" if the unit has been properly installed.
- If the unit has not been installed yet, observe the instructions in the chapters "Transport, Assembly and Storage" and "Assembly Instructions".

## 2. Safety instructions



These safety instructions apply to all persons within the range of action of the equipment.

Please inform all persons within the range of action of the equipment of the direct and indirect hazards connected with the equipment.

These operating instructions are to be used by all persons assigned activities connected with the equipment.

Knowledge of the English language is prerequisite.

Ensure in each case that the operating personnel are familiar with the operating instructions and the function of the equipment.

## **2.1. For your safety**

### **General**

The operating personnel of this equipment must be at least 16 years old.

Please read these operating instructions carefully before taking into operation for the first time. Contact us should questions arise. This avoids injury and damage to equipment!

These operating instructions must be kept available at all times at the place of operation of the equipment. Improper operation results in danger of accidents!

Please note that, for reasons of clarity, not all conceivable cases regarding operation or maintenance of the equipment can be covered in these operating instructions.

Please observe all safety instructions and warnings on the equipment. This avoids injury and damage to equipment!

All work on the equipment is to be carried out by persons whose qualifications are specified in the pertaining chapters of the operating instructions. Improper operation results in danger of accidents!

The proper working clothes are to be worn during any work on the equipment. This avoids injury!

The local regulations and requirements pertaining to this equipment must be observed.

Disconnect electrical components from the mains supply before work is carried out on these components. Caution: Danger to life through electrical shock!

Compile detailed operating instructions based on these Operating instructions for the sequence of procedures to be carried out on this equipment. Improper operation results in danger of accidents!

Please note that sound levels exceeding 85 db(A) may in the long term damage your health. Use the appropriate ear muffs. This avoids impairment of hearing!

**Assembly**

Compare the connected loads with those of the mains supply. Danger of injury through electrical shock!

When using lifting gear, please observe the pertaining regulations. Caution: Danger of accidents!

Do not modify, add other equipment or change the design of the equipment without the approval of the manufacturer. Caution: Danger of accidents!

Attachments not supplied by Sterling must be manufactured in accordance with safety regulation EN 294. Danger of accidents!

The equipment may only be operated when all the associated components are properly connected up and in accordance with the relevant regulations. This avoids injury and damage to equipment!

Operate the device only if all its components are grounded. Danger: accident through electrical shock!

Solid particles and dust must be separated before entry to the vacuum generator. This avoids damage to equipment!

If PVC hoses are used for conveying, they must be grounded. This avoids injury and damage to equipment!

An acoustic cover should be installed when vacuum generators are located in work rooms. This avoids impairment of hearing!

**Operation**

Appoint an equipment foreman to be responsible for the equipment.

Ensure that the operating personnel are provided detailed instruction in the operation of the equipment. Improper operation results in danger of accidents!

When the main switch is switched off for reasons pertaining to safety, it must be secured against unauthorized activation. Caution: Danger of accidents!

Repair work may be carried out by trained personnel only. Caution: Danger of accidents!

Never operate the equipment when partially dismantled! Danger! Limbs may be caught in machinery! Electric shock!

In case of malfunction, shut down the equipment immediately. Have malfunctions corrected immediately. Danger of accidents!

The equipment is intended only for conveying granulated plastics and regrinds. Any other or additional use is contrary to specifications.

This equipment is not suitable for food processing.

The safety instructions of the connected machines must be followed.

Explosive gases and mixtures of gas and air must not be conveyed. Danger of explosion! Avoids injury or damage to equipment!

**Maintenance**

Before starting maintenance work, appoint a supervisor.

Inform the responsible personnel before maintenance work on the system is started. Caution: Danger of accidents!

Disconnect the equipment from mains supply before starting maintenance procedures to ensure that it cannot be switched on unintentionally. Caution: Danger of accidents!

All pipes, hoses and screwed connections should be checked regularly for leaks and damage. Any faults which arise should be corrected immediately. Danger of accidents!

Depressurise all compressed air piping before starting maintenance work. Danger of accidents!

## **2.2. For the operating safety of the equipment**

Never change settings if the consequences are not precisely known.

Use only original Sterling spare parts.

Please observe the maintenance schedule.

Keep record of all maintenance and repair work.

Please note that electronic components may be damaged by static discharge.

Check all electrical connections for proper fit before the equipment is taken into operation for the first time and at regular intervals.

Please ensure that the permitted operation temperature lies between 0 °C and +45 °C (32 to +113 °F).

Please ensure that the permitted storage temperature lies between -25 °C and +55 °C (-13 to +131 °F).

Note down all data which you have entered into the control system.

Please ensure that all plugs are correctly plugged in.

The operating instructions of the connected machines must be followed.

Operate the device only if all its components are grounded.

Never adjust sensors without exact knowledge of their function.

Please note that a compressed air supply is required for the operation of the unit (only SSE-2 with active cleaning, optional).

Never set a higher operating pressure than 6 bar for the hopper loaders (system overpressure, only SSE-2 with active cleaning, optional).

Align the suction tubes correctly.

The unit should be installed in such a way that the outlet flap oscillates at right angles to the moving direction of the equipment.

The load-bearing capacity of the machine flange should be adhered to.

Please observe that a level indicator is required when conveying from granulators.

Observe that the maximum conveying capacity is up to 180 kg/hr (390 lbs/hr) at 100% operating time.

Observe that the typical conveying capacity is up to 90 kg/hr (195 lbs/hr) at 50 % operating time.

---

### 3. Putting into operation



This chapter is intended for operating personnel.

Prerequisite for this chapter is general knowledge of the operation of conveying systems.

Also prerequisite for this chapter is that the functional description has been read and understood.

Ensure in each case that the operating personnel are sufficiently informed.



Make sure the plastic stopper has been removed from the material inlet nozzle.

Make sure the adhesive tape has been removed from the exit flap.

### **3.1. Checking the pipe system**

Remove the flexible hose from the connected material takeup.

Close the open end of the hose with your hand.

Connect the unit to mains supply by the device plug.

If the turbine is operating, your hand must feel the suction within few seconds.

If you don't feel the vacuum it means that the pipe system is not tight.

Check the pipe system and seal any untight points you may have identified.

Reconnect the conveying hose.

Disconnect the unit from mains supply by the device plug.



### 3.2. Adjusting the suction pipes

The suction pipes have to be adjusted exactly to ensure troublefree operation.

1. Set the suction pipes to their home position.



At home position the inner pipe of the suction pipe protrudes about 120-160 mm (4.75" - 6.25") from the outer pipe at the top end.

2. Start a conveying operation.

Connect the unit to mains supply by the device plug.

3. Observe the flexible hose at the suction pipe.

The flexible hose must not show any pulsating movement.

4. Observe the flexible hose at the separator.

The conveying hose must only move during in-feed.

**If the conditions (points 3 + 4) are not met:**

Pull the inner pipe further out of the outer pipe until there is no more jerky conveyance.

**If the conditions (points 3 + 4) are met:**

Push the inner pipe slowly into the outer pipe until pulsating of the flexible hose or shock conveyance occurs.

Now pull the inner pipe slightly back again until the hose stop pulsating.

Select a setting between the two pipes to ensure that enough air can flow into the material pipe.

Once you have reached a satisfactory conveying result turn the wing screw at the suction pipe tight.

### 3.3. Setting the controller



The filling capacity of the hopper loader may not exceed the material inlet.



The setting is independent of the conveying line and the material to be conveyed.

It is only possible to set the conveying time/line clear time when the unit is not conveying any material.

#### Setting the conveying time

Press the “arrow key”.

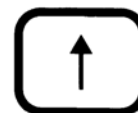

The conveying time which was last selected appears in the display.

1-99 seconds may be set for the conveying time.

#### The conveying capacity is too highlow (the separator is overcrowded):

Reduce the conveying time.

#### The conveying capacity is too low:

Increase the conveying time.

### Setting the line clear time

Press the “change-over” key and



then the “arrow key”.



The line clear time which was last selected appears in the display.  
0-99 seconds may be set for the line clear time.



If no line clear valve has been installed enter “0”.

### 3.4. Initial conveying operations

Metal shavings may be inside the pipe from cutting down pipes into lengths. These are pulled during the first conveying process and collected in the separator.



This material should not be used again.

### 3.5. Switching off the unit

Disconnect the unit from mains supply by the device plug.

## 4. Error and error correction



This chapter is intended for the operating personnel of the equipment.

Prerequisite for this chapter is general knowledge of the operation of conveying systems

The “Start-up” description must have been read and understood.

Ensure in each case that the operating personnel are sufficiently informed.

If a disturbance occurs in the unit, an alarm message will be issued (option, only if the alarm indicating device has been activated).



An "E" appears in the display and an error number.  
The alarm indicating device (signal siren, horn) reacts.



The control system can only restart operation when the malfunction has been corrected.

Press the "acknowledgement key".



The cause of the malfunction will not be corrected by pressing the "acknowledgement key".

**The following error messages can be displayed:**

**"E1"**

The alarm message "E1" is displayed when no material has been conveyed during 3 consecutive conveying cycles.

Check that sufficient material is being conveyed.

Check that the flap switch is set correctly.



When the malfunction has been corrected press the key.

**“E2”**

If the control system becomes too hot during operation (>70°C, 158°F) the “E2” alarm message is displayed and the unit is switched off.

Ensure that the control system is sufficient cooled.



The unit starts automatically after the cooling down phase.

## 5. Maintenance

This chapter is intended for persons with skills in electrical and mechanical areas due to their training, experience and received instructions.

Personnel using the instructions in this chapter must be instructed of the regulations for the prevention of accidents, the operating conditions and safety regulations and their implementation.

Ensure in each case that the personnel are informed.

For maintenance work taking place at heights of over approx. 6 feet, use only ladders or similar equipment and working platforms intended for this purpose. At greater heights, the proper equipment for protection against falling must be worn.

Use only suitable lifting gear which is in proper working order and load suspension devices with sufficient carrying capacity. Do not stand or work under suspended loads!

Ensure that the electric motors/switch cabinets are sufficiently protected against moisture.

Use only suitable workshop equipment.

Before starting maintenance work, appoint a supervisor.

Inform the responsible personnel before maintenance work on the system is started.

Never operate the equipment when partially dismantled.

All maintenance and repair work **not** described in this chapter may only be carried out by Sterling service personnel or authorized personnel (appointed by Sterling).



Disconnect the equipment from mains supply before starting maintenance procedures to ensure that it cannot be switched on unintentionally.

Depressurize all system sections of the equipment before carrying out any repair work.



Please observe the maintenance intervals.

Before starting maintenance work, clean the equipment of oil, fuel or lubricants.

Ensure that materials and incidentals required for operation as well as spare parts are disposed of properly and in an environmentally sound manner.

Use only original Sterling spare parts.

Keep record of all maintenance and repair procedures.



## 5.1. Maintenance intervals

Daily:	Check warning signs on equipment for good legibility and completeness  Clean the sieve / filter (= units with active cleaning): Use compressed air to blow through the sieve / filter (according to the accumulation of dust)
Monthly:	Check function of the device plug
Every 6 months:	Check all electrical and mechanical connections for tight fit  Check setting of the level sensor (if present, optional)  Replace the sieve / filter (= units with active cleaning) (according to the accumulation of dust)
Annually:	Replace outlet valve sealing.  Adjust valve switch
After 1000 operating hours:	Replace carbon brushes



The given maintenance intervals are average values.

Check whether in your individual case the maintenance intervals must be shortened.

## 5.2. Servicing the conveyor



Disconnect the unit from mains supply by the device plug.

Depressurize all system sections of the equipment (only units with active cleaning).

Disassembly the unit.

### 5.2.1. Changing the sealing ring of the outlet flap

Open the toggle-type fasteners (A) and the flap (B) of the hopper loader.

Draw the old sealing ring (C) off the nozzle of the material outlet.

Install the new sealing ring (C).

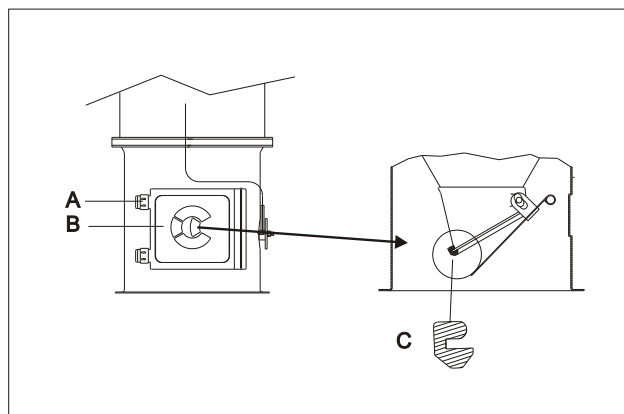

Installation sealing ring



Observe the direction of installation (C).

Close the flap (B) and the toggle-type fasteners (A).

Install the hopper loader.



Order number sealing ring "material outlet": ID 29258

### 5.2.2. Adjusting the flap switch

Remove the connecting plug “flap switch” from the connection housing of the hopper.

Connect an ohmmeter to PINS 2 and 3 of the connecting plug “flap switch”.

Release the nuts (A) of the flap switch (B) until the support can be displaced.

Open the outlet flap (C) so far that the front tip of the outlet flap is approx. 30 mm (1.2") away from the sealing surface.

Displace the flap switch (B) until the contact of the magnet switch is closed.

Tighten the nuts (A) of the flap switch.

Check the adjustment:

In case of free hanging outlet flap (empty hopper loader) the contact of the magnet switch must be closed.

If the outlet flap cannot be properly adjusted, replace the flap switch or the outlet flap with magnet.

Install the hopper.

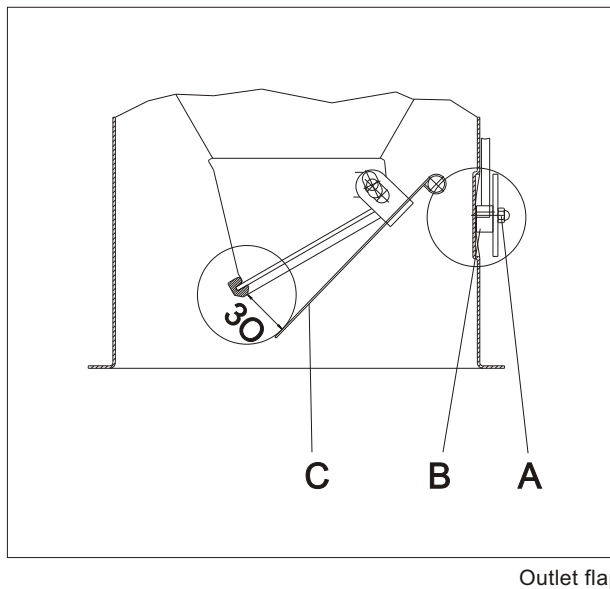

Order numbers

switch with plug:

ID 29570

outlet flap with magnet:

ID 28647

### 5.2.3. Cleaning the unit

Open the tension ring.

Fold the turbine head upwards.

Remove the sieve.

Clean the sieve by means of compressed-air.

Clean the hopper loader by means of a vacuum cleaner.

Mount the sieve. Pay attention for proper fit.

Mount the turbine head.

Mount the tension ring.

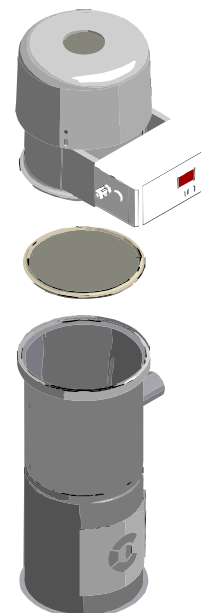

#### or optional, active cleaning

Open the tension ring.

Fold the turbine head upwards.

Remove the filter.

Clean the filter by means of compressed-air.

Clean the hopper loader by means of a vacuum cleaner.

Mount the filter. Pay attention for proper fit.

Mount the turbine head.

Mount the tension ring.

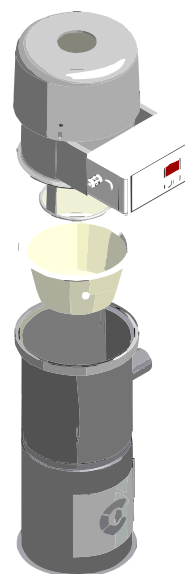

Order number

sieve with sealing ring: ID 35014

filter with sealing: ID 37755

Open the toggle-type fasteners (A) and the flap (B) of the hopper loader.

Check the filter cloth (C) and the wire cloth (D) for material residue. Clean the filter by means of compressed air.

Close the flap (B) and the toggle-type fasteners (A) on the flap of the hopper loader.

Install the unit.

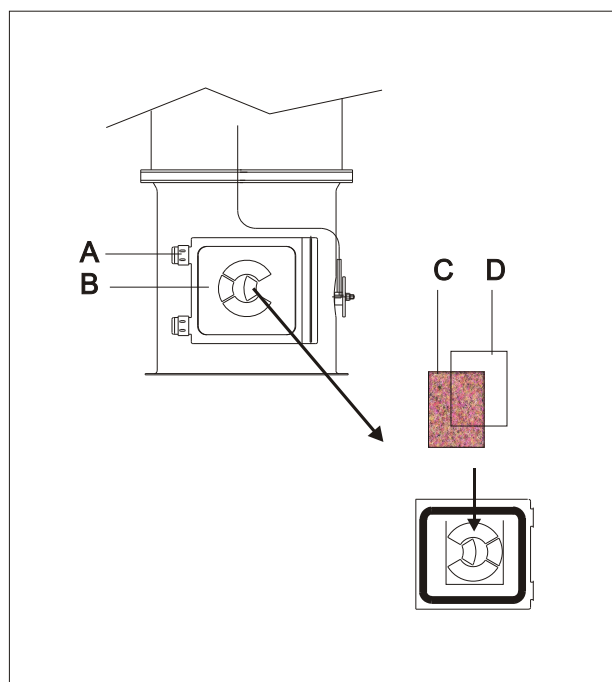

SSE-2



#### Order numbers

Filter cloth:	ID 28626
Wire cloth:	ID 23091

### 5.3. Replacing carbon brushes at turbine



This work must be carried out by qualified personnel only.

Disconnect the unit from mains supply by the device plug before you begin with works on the controller. Danger to life!

Depressurize all system sections of the equipment (only units with active cleaning).

Disassembly the unit.

Remove the screws (A) at the lid.

Remove the lid (B).

Remove the latchet carefully from the brush holder (C).

Remove the cover (D).

Loosen the brush holder lock.

Pull out the brush holder.

#### Installation

Push the latchet with the connecting line onto the new brush holder.

Mount the brush holder.

Please be careful with the latchet connecting line.

Mount the cover.

Mount the lid.

Mount the screws at the lid.

Install the unit.

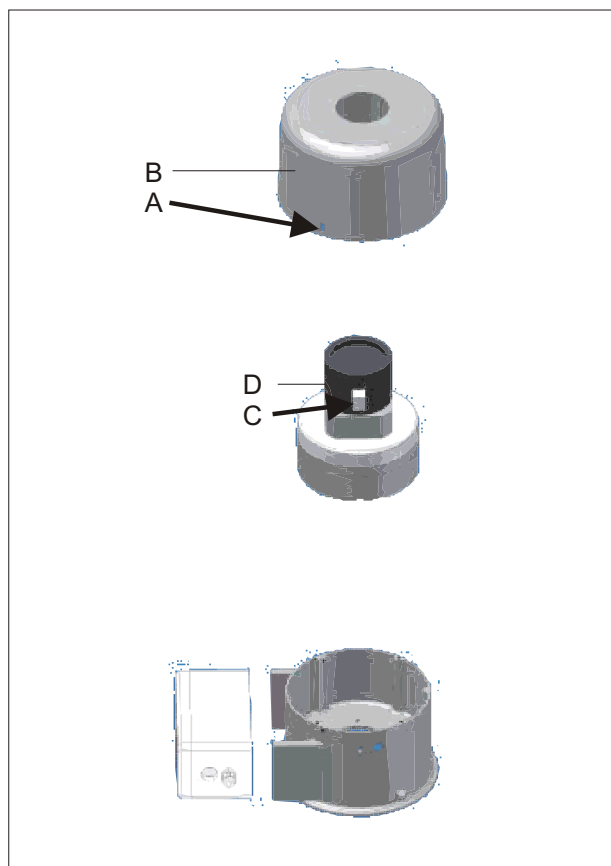

SSE-2



Observe that no cables will be squeezed.  
Carbon brushes can be replaced twice.  
After that the turbine has to be completely replaced.



Order numbers

Turbine (230 V, 800 W):	ID 85629
Carbon brushes (switching off):	ID 85628
Turbine (110 V, 800 W):	ID 85844
Carbon brushes (switching off):	ID 84716

## 6. Functional description



This functional description is intended for all operating personnel of the equipment.

Prerequisite for this functional description is general knowledge of conveying systems.

Ensure in each case that the operating personnel are sufficiently informed.



## 6.1. General

The single conveyor unit functions according to the principle of suction conveyance. A high-performance turbine, mounted permanently on the device, provides for the vacuum that is required to convey the material into the separator.

In the separator the material is separated from air. After the conveying time is finished the turbine is switched off and the material emptied into the material intermediate hopper. If the filling level remains below the outlet flap of the single conveyor unit, a starting pulse is triggered and sent to the controller.

The filter will be cleaned (passive cleaning) or blown off using compressed-air (optional, active cleaning). Then the conveyance is restarted. This process repeats so often until the material intermediate hopper is filled. Afterwards the conveyance is stopped until a new starting pulse is triggered and sent to the controller.

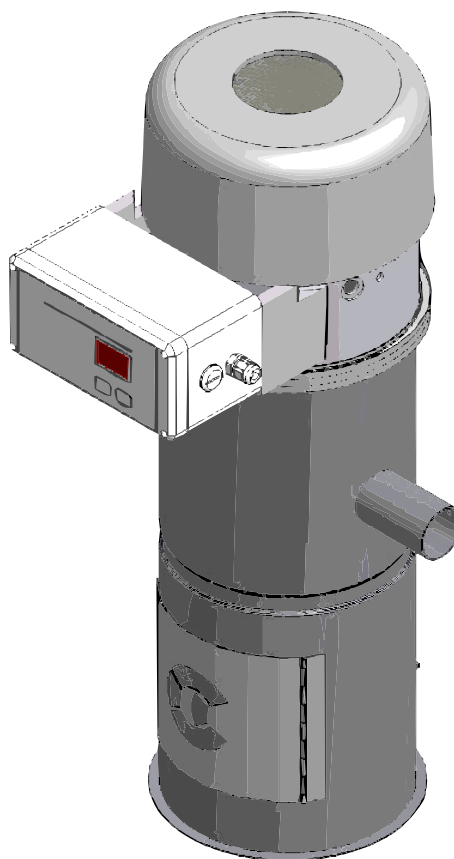

## 6.2. Controller

The control system is mounted on the separator lid.

The setting for the conveying time and the line clear time are made via the keys (A1: “change-over” key, A2: “arrow key”) on the front of the control system. The values which have been set will be displayed on the display (B). The values which have been set are maintained after the machine has been shut off.

3 LEDs indicate the respective modes of operation: cleaning (C), conveying (D), line clearing (E).



The conveying time can be set from 1 to 99 seconds.  
The line clear time can be set from 0 to 99 seconds.  
The clearing time consists of 2 seconds.  
The emptying time consists of 8 seconds.  
When the unit is switched on all LEDs blink and the software version is displayed.

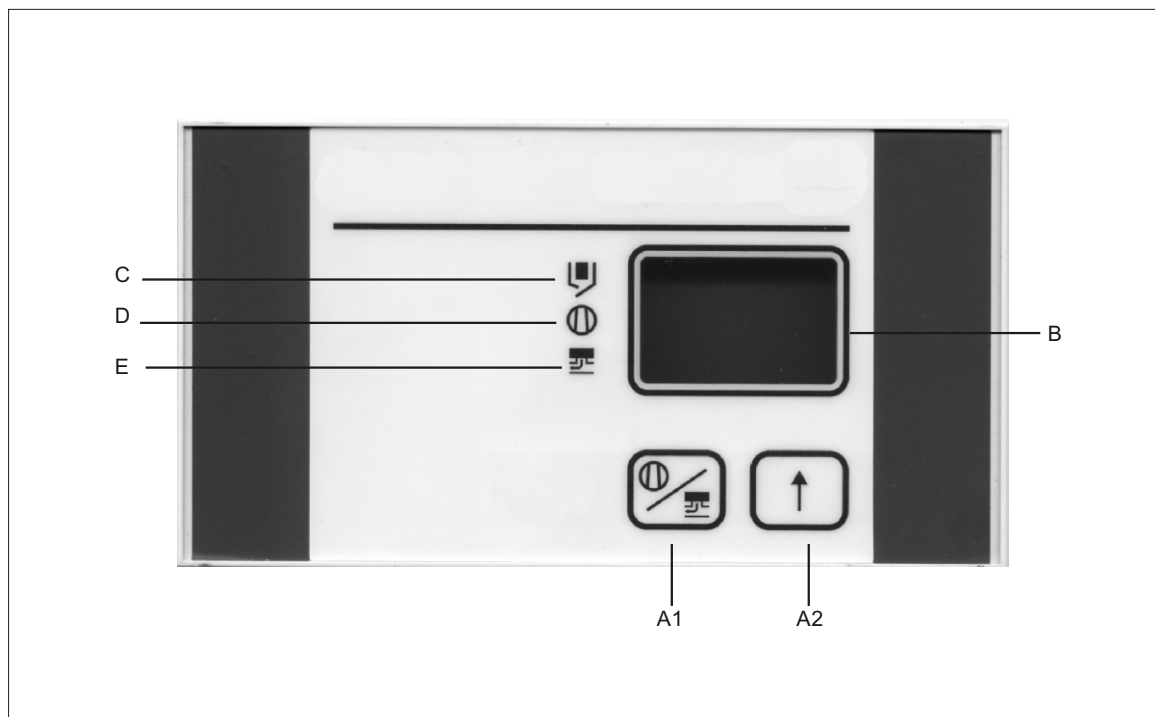

Controller

**Optional:**

If a material clearing valve has been installed residues of flowing material will be cleaned from the conveying line during the line clear time.

If a disturbance occurs in the unit, an alarm message will be issued (only if the alarm indicating device has been activated).



An "E" appears in the display and an error number.

The alarm indicating device (signal siren, horn) reacts.

## 7. Transport, Assembly and Storage



This chapter is intended for all operating personnel of the equipment.

Personnel using these instructions must be instructed in the regulations for the prevention of accidents, the operating conditions and safety regulations and their implementation.

Ensure in each case that the operating personnel are sufficiently informed.

Please inform all persons within the range of action of the equipment of the direct and indirect hazards connected with the equipment.

Please observe all safety regulations for the operation of lifting equipment.

## 7.1. Transport and Packing



Please ensure adequate carrying capacity of the lifting equipment.

The equipment pass a rigorous operating test in the factory and are packed carefully to avoid transport damage.

Please check packing on delivery for transport damage.

The inlet and discharge flanges are sealed with plugs, so that no dirt can enter during transport. Plugs must be removed before assembly.

Packing materials should be disposed of according to environmental laws or reused.

Only use for transport of the equipment a suitable lifting device (e. g. a fork lift truck or a workshop crane).

Transport must be shock-proofed and free from vibrations.

## 7.2. Assembly



Please ensure adequate carrying capacity of the lifting equipment.

Check the carrying capacity of the point of installation, particularly if installed on a platform.

The place selected for installation should be as free of vibrations as possible.

The main switch must be freely accessible.

Ground the equipment against electrostatic charging.

## 7.3. Storage

The control system may only be stored at temperatures from -25 to +55°C (-13 to +131 °F).

Between delivery and machine commissioning the equipment should be stored in a dry, dust-free and vibration-free room.

## 8. Assembly instructions



These installation instructions are intended for persons with skills in electrical and mechanical areas due to their training, experience and received instructions.

Personnel using these installation instructions must be instructed in the regulations for the prevention of accidents, the operating conditions and safety regulations and their implementation.

Ensure in each case that the personnel are informed.

The installation instructions provided in the corresponding operating instructions apply for all connected equipment.

Please observe all safety regulations for the operation of lifting gear.

All installation work must be carried out with the equipment disconnected from electrical power and compressed air supply.



For installation work taking place at heights of over approx. 6 feet, use only ladders or similar equipment and working platforms intended for this purpose. At greater heights, the proper equipment for protection against falling must be worn.

Use only suitable lifting gear which is in proper working order and load suspension devices with sufficient carrying capacity. Do not stand or work under suspended loads!

Use only suitable workshop equipment.



Install the equipment such that all parts are easily accessible; this facilitates maintenance and repair work.

## 8.1. Assembly

The single conveyor unit is insensitive to shocks and can be mounted directly onto the processing machine, on a machine hopper, a drying hopper or a dosing and blending unit.

The equipment is delivered as a complete assembly.

Unpack the equipment.

Remove the plastic stopper (A) from the material inlet nozzle.

Open the flap (B) and remove the adhesive tape from the exit flap.



The controller must be freely accessible.

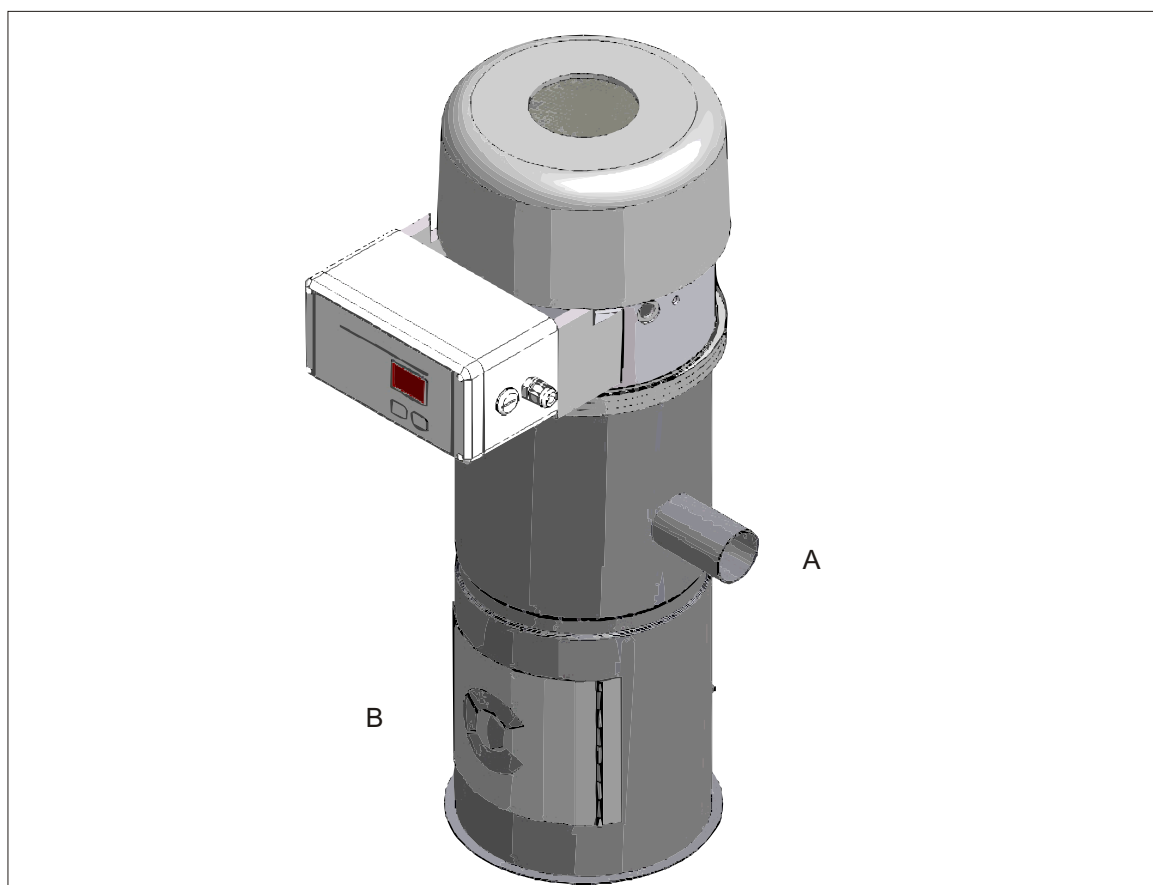

Mounting on fixed machine throats or intermediate containers is done by means of strap retainers.

Please check during assembly that the admissible bearing loads are not exceeded.

Mount the conveyor in such a way that the outlet flap swings in a right angle to the direction of machine movement.

Please check that all connecting points are tight to ensure that the conveying performance is not impaired.

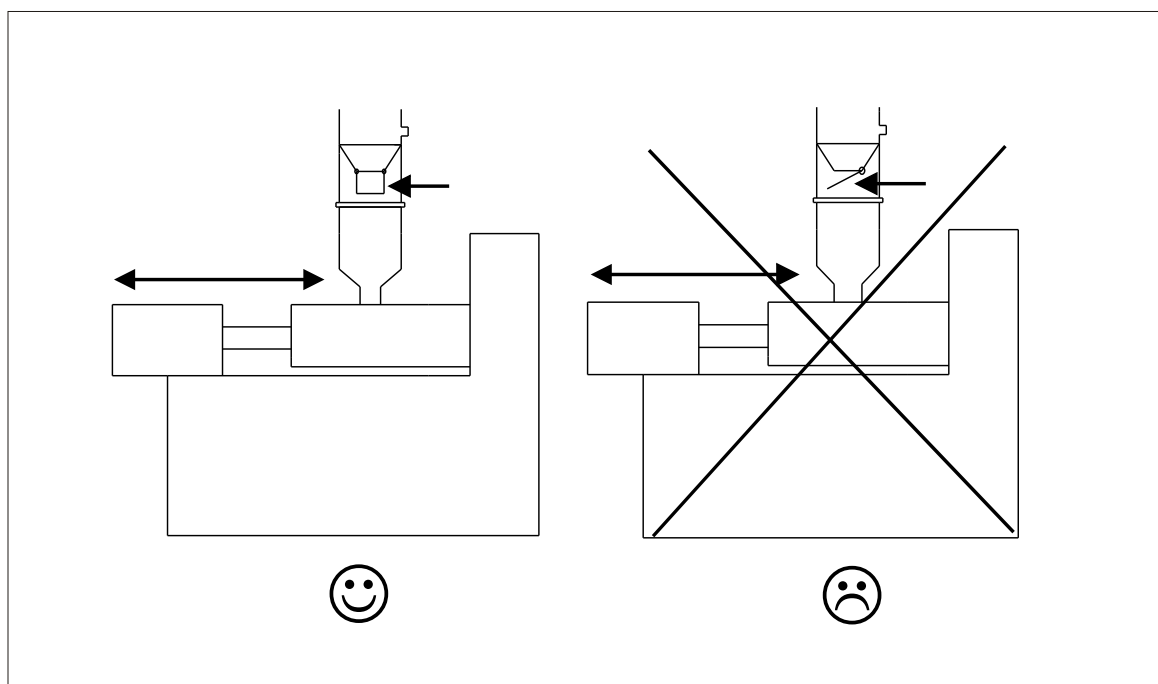

Assembly



## 8.2. Mounting on the processing machine

**A material hopper VT 1,0 is required:**

Mount the material hopper onto the flange of the processing machine.

Mount the unit onto the material hopper.

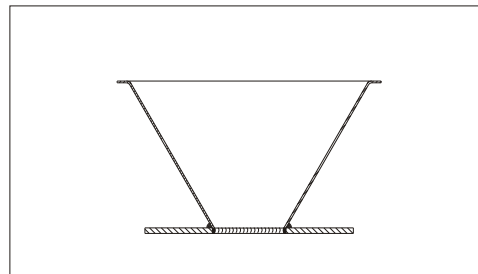

VT 1,0



Observe the bearing capacity of the machine flange.

## 8.3. Mounting onto a machine hopper

**A welding flange EF 190 is required:**



Please observe all safety regulations for the operation of welding equipments.

Always wear a safety goggle.

Weld the welding flange into the machine hopper lid.

Mount the unit onto the flange.

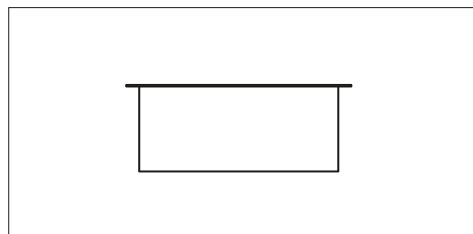

EF 190

#### 8.4. Mounting onto mixing hoppers with lateral inlet

**A material hopper VT 1,0 is required:**

Mount the material hopper onto the swan-neck of the mixing hopper.

Mount the unit onto the intermediate hopper.

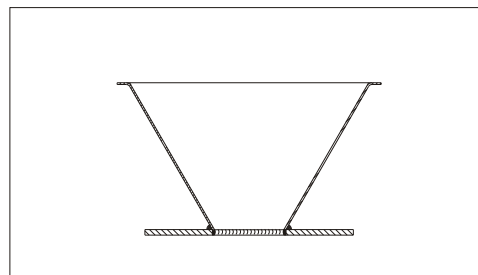

VT 1,0



Observe the bearing capacity of the machine flange.

#### 8.5. Mounting onto dosing station DT 30

**A dosing hopper DT 30 (320 mm high) is required:**

Mount the dosing hopper directly onto the dosing container of the dosing station DT 30.

Mount the unit onto the dosing hopper.

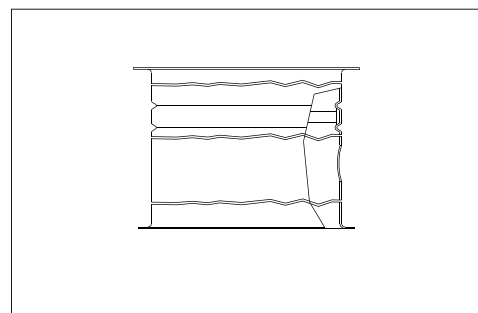

DT 30



Observe the bearing capacity of the machine flange.

## 8.6. Material feed

Suction pipes type MV may be tilted by approx. 45 degrees in either direction to the vertical. Additional fastening is not required.

When conveying from the bottom of storage containers (silos), a suction box with 1-3 suction pipes is required.

The connection of the suction pipes must be carried out with a piece of flexible line to provide sufficient movement.

Please observe that the length of the hose should not exceed 3 meters (10 feet). Push the free pipe end into the flexible line to a depth of approx. 4-5 cm (1.5" - 2"). Connect both parts by means of a hose clamp.

## 8.7. Mounting the suction pipe MV

The suction pipe consists of an inner pipe (A) and an outer pipe (B) which can be offset against each other.

Connect the inner pipe with the straight end to a flexible hose:

Push the free pipe end into the flexible line to a depth of approx. 4-5 cm (1.5" - 2").

Connect both parts by means of a hose clamp.

Please observe that the length of the hose should not exceed 3 meters (10 feet).

Please check that the outer pipe is not covered as it provides for unhindered access of ambient air.



When conveying from silos, material hoppers and storage containers, a suction box with 1-3 suction pipes is required.

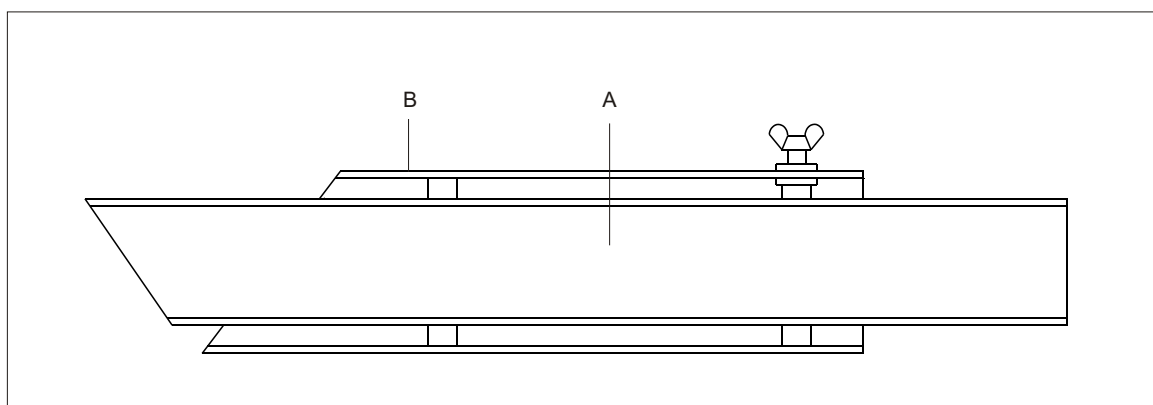

MV

## 8.8. Pipework

If PVC hoses are used for conveying, they must be grounded: draw out the copper lead on both ends of the hose and jam it between hose and tube. For fastening, use threaded clamps.

## 8.9. Electrical connection



The regulations of the local Electricity Board must be observed.

Before connection to the electricity supply, it should be ensured that the supply voltage and the power frequency are in accordance with the data on the name plate of the machine.

The electrical connection may only be carried out by Sterling service staff or trained personnel authorised by Sterling.

It is not permitted for other persons to undertake the electrical connection.

The main switch must be freely accessible.

Ground the equipment against electrostatic charging.

The operating voltage is 230 V/50 Hz.  
Special voltages on request.

The connected load is approx. 800 W.

The equipment is connected to mains supply by a device plug.

Separate fuse protection of the wall socket is required (max. 16 A).

### 8.9.1. Installation of the “flap switch” signal line

Insert the appliance plug of the “flap switch” signal line into the “flap switch” connector (A) on the lower side of the controller.

### 8.9.2. Installation of the signal line of the SKW (optional)

Insert the appliance plug of the "SKW (= Two Component Proportioning Valve)" signal line into the “SKW” connector (B) on the lower side of the controller.

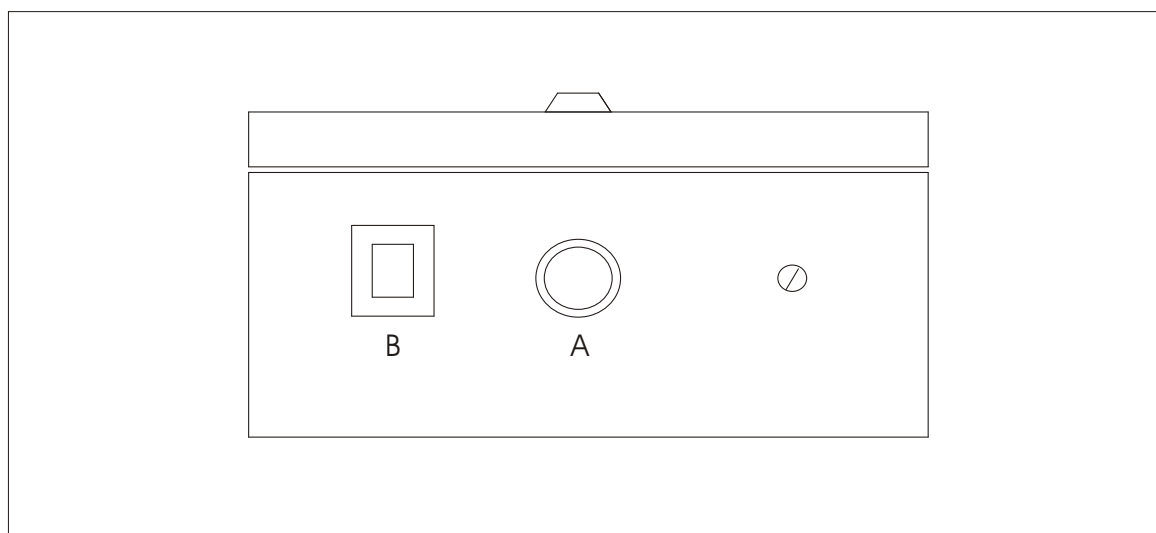

Lower side of the controller

### 8.9.3. Installation of the alarm indicating device (optional)



This work must be carried out by qualified personnel only.

Disconnect the unit from mains supply by the device plug before you begin with works on the controller. Danger to life!

The connection is potential-free and rated for no more than 100 VA.



An additional alarm indicating device (e.g. horn, signal light) can be connected.  
You need an "acknowledgement key" for 24 V (e.g. by Rafi Company).

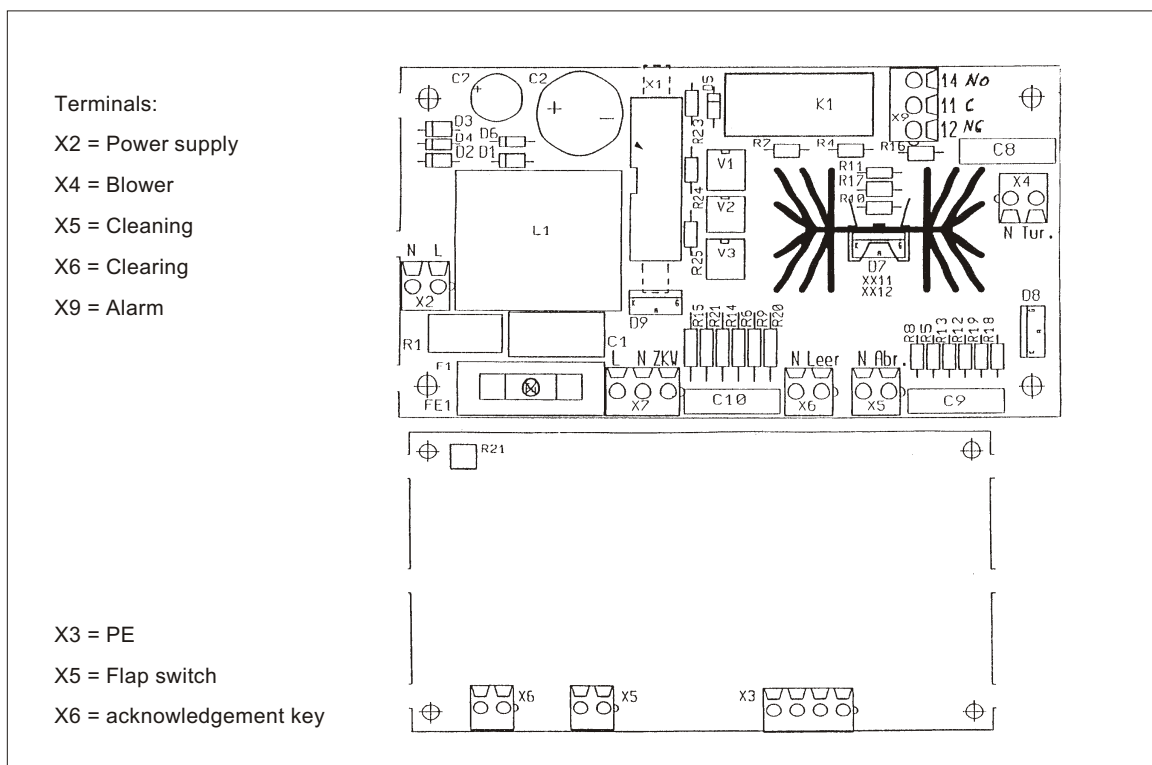

### 8.10. Compressed-air supply (only SSE-2 with active cleaning)

For operating the cleaning device, a compressed-air supply is necessary.

Check compressed-air piping for correct installation and assembly.

Check fittings, length and quality of the hose connections for agreement with requirements.

The operating pressure is 5-6 bar (72-87 PSI) (system overpressure).

Check the compressed-air supplied by the plant's supply network.

Adjust compressed-air pressure to 5-6 bar (72-87 PSI) (system overpressure).

Connect the unit to the plant's supply network by means of a hose.



Depressurize compressed-air supply lines which must be opened.



Compressed air must be dewatered, dustfree and oilfree.

Install a maintenance unit if required.

Adjust pressure to a max. value of 6 bar (87 PSI) (system overpressure).

### 8.11. Installing the accessories



See chapter "Accessories".

## 9. Technical data



These instructions apply to all persons within the range of action of the equipment.

These operating instructions are to be used by all persons assigned activities connected with the equipment.



**SSE-2****Basic Version**

- Integrated control with:
  - LED-display
  - indication of the respective modes of operation
  - adjustable conveying time
  - adjustable line clearing time
  - two component valve output
- Integrated vacuum pump
- Integrated filter-sieve
- Parts coming in contact with material are made of stainless steel
- Simple mounting to dosing and blending units due to compact and weight saving design

**Optional Features**

- Integrated filter with automatic cleaning
- Alarm indicating device
  - display of error codes
  - alarm output
  - automatic shut-down with lack of material
- Level sensor input when in use with granulators
  - automatic clearing prevents overcharging of the granulator
- Material clearing valve

**Performance**

- Conveying capacity max. up to 180 kg/hr (390 lbs/hr) at 100 % operating time
- Hopper loader capacity: ca. 2 l (.07 cu. ft.)
- Connected load: 230 V, AC, N, PE, 50/60 Hz, 0,8 kW; 110 V, AC, N, 60 Hz
- Material temperature max. 80 °C (176°F)
- Noise level max. approx. 80 db(A)
- Weight approx. 10 kg (22 lbs.)
- Air consumption (only with active cleaning): max. 10 l at 6 bar / per cleaning cycle (.35 cu. ft. at 87 PSI)

## Dimension Sheet

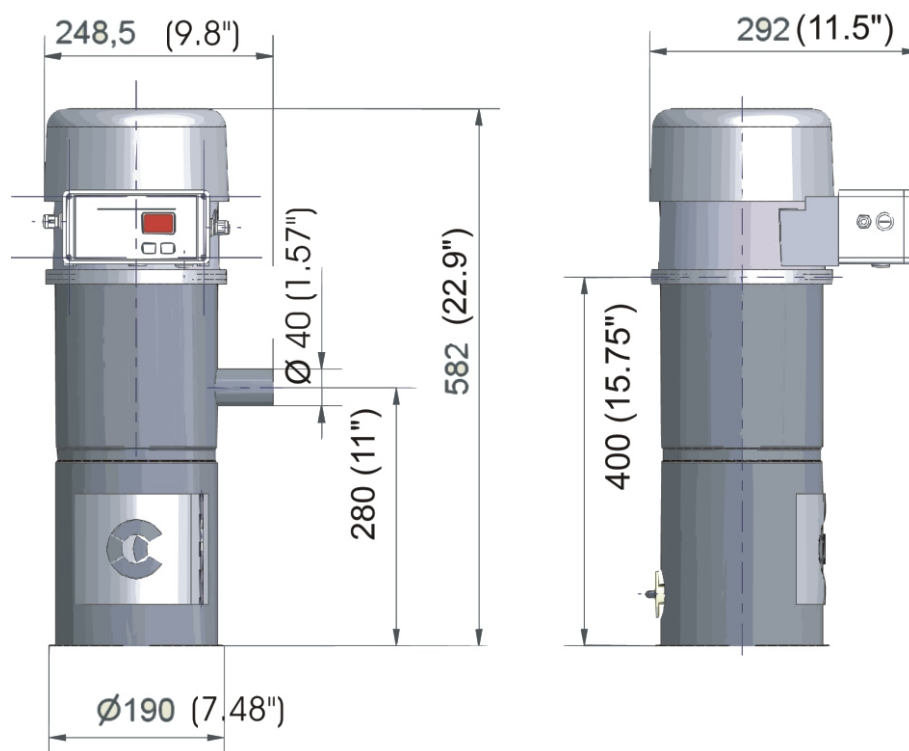

Dimensions and data without obligation. Dimensions in mm. Specifications may be subject to alterations.

## 10. Spare parts list



This spare parts list is intended to be used only by trained personnel.  
Other persons are not permitted to modify or repair the equipment.



Wear Code:

A = Wearing part, fast used up

B = Wearing part

C = Spare part, storekeeping for 1 year

D = Spare part, storekeeping for 2 years

E = Spare part, storekeeping for more than 2 years

SSE-2, 230 V, 50 Hz / 110 V, 60 Hz

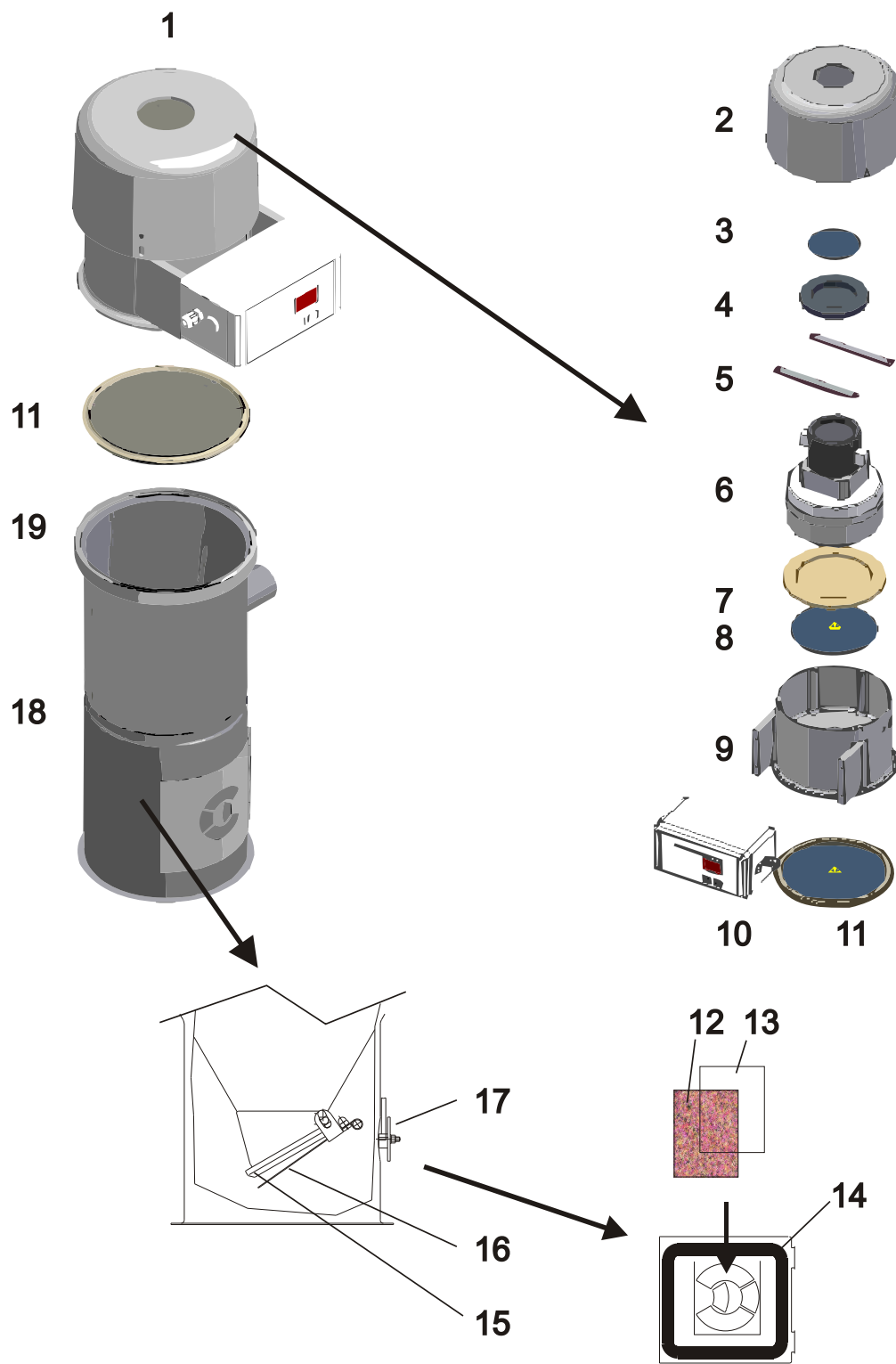

**10.1. SSE-2, 230 V, 50 Hz**

<b>Pos.</b>	<b>Order no.</b>	<b>Designation</b>	<b>Wear Code</b>
1	37767	Turbine head complete, with turbine and controller	
2	37765	Covering cap	
3	18491	Sieve	
4	34197	Isolation	
5	37768	Support	
6	85629	Turbine (800 W)	D
	85628	Carbon brushes (switching off)	B
7	24679	Isolation	
8	26384	Filter round	
9	37764	Turbine lower part	
	98194	Cable bushing	
10	83098	Controller	
11	35014	Sieve with sealing ring	A
12	28626	Filter cloth	C
13	23091	Wire cloth	C
14	28625	Sealing	C
15	29258	Sealing ring	A
16	28647	Outlet flap with magnet	
17	28839	Flap switch with plug	C
	26462	Covering	C
18	37761	Separator	
19	85481	Tension ring	
	29299	Sealing ring	B
	26451	Lock	

**10.2. SSE-2, 110 V, 60 Hz**

<b>Pos.</b>	<b>Order no.</b>	<b>Designation</b>	<b>Wear Code</b>
1	37777	Turbine head complete, with turbine and controller	
2	37765	Covering cap	
3	18491	Sieve	
4	34197	Isolation	
5	37768	Support	
6	85844	Turbine (800 W)	D
	84716	Carbon brushes (switching off)	B
7	24679	Isolation	
8	26384	Filter round	
9	37764	Turbine lower part	
	98194	Cable bushing	
10	83097	Controller	
11	35014	Sieve with sealing ring	A
12	28626	Filter cloth	C
13	23091	Wire cloth	C
14	28625	Sealing	C
15	29258	Sealing ring	A
16	28647	Outlet flap with magnet	
17	28839	Flap switch with plug	C
	26462	Covering	C
18	37761	Separator	
19	85481	Tension ring	
	29299	Sealing ring	B
	26451	Lock	

**10.3. SSE-2, 230 V, 50 Hz with active cleaning**

<b>Pos.</b>	<b>Order no.</b>	<b>Designation</b>	<b>Wear Code</b>
1	37755	Filter with sealing	A
2	37222	Basket	
3	82593	Solenoid valve	B
4	97745	Bush	D
5	37800	Breather tube	D

**10.4. SSE-2, 110 V, 60 Hz with active cleaning**

<b>Pos.</b>	<b>Order no.</b>	<b>Designation</b>	<b>Wear Code</b>
1	37755	Filter with sealing	A
2	37222	Basket	
3	82592	Solenoid valve	B
4	97745	Bush	D
5	37800	Breather tube	D

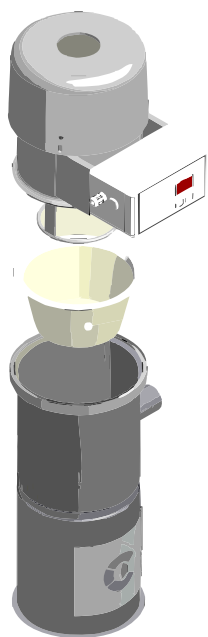

## 10.5. Accessories



Please observe the operating manuals in chapter 11.



## 11. Accessories

- 
- 
-

## 12. Electrical manual



This electrical manual is intended to be used only by Sterling service personnel and trained personnel authorized by Sterling.

Other persons are not permitted to modify or repair the equipment.

Connection diagram no.: \_\_\_\_\_

Currently not available; will be delivered at a later date !