

AIR BOSS® MODEL 75



Air Purification System



Qualified to UL Specification
YYXS-YYXS7

Hood and Duct Accessories

UL File #MH27669

New York City, Department of Buildings

MEA 288-01-E and 88-99-E

TRION®
air purification systems

ENGINEERED SOLUTIONS FOR CLEAN AIR



THERE ARE CERTAIN THINGS YOU EXPECT FROM AN AIR PURIFICATION SYSTEM.

A perfect fit for your specific application...effectiveness...availability. For even more value, add a variety of applications and simplicity of operation. Back all these features up with substantial product and application expertise, superb technical services and unconditional support anywhere, anytime, and you've got the first name in air purification systems: Trion.

Since 1947, Trion has combined the leading-edge technology you expect with the value-added services you want to provide unique, effective air purification solutions for numerous applications in industrial and commercial markets.

NUMEROUS APPLICATIONS. ONE SOLUTION.

When you need one system for cleaning numerous applications, such as kitchen grease and smoke, oil mist, and contaminants from other industrial processes, Trion has the kitchen exhaust, commercial, and large industrial solutions just for you.

Atmospheric contaminants may be either liquids or solids, in the form of oil, water, grease, smoke, fumes, dusts or similar particulate including gaseous and vaporous odors. The Model 75 readily adapts to the various air collection methods utilized

to recover contaminants for collection. Air inlet and outlet flanges on the modules include predrilled holes to connect adjoining duct work. Module support rails are optional for multiple mounting methods.

With your unique needs in mind, the Trion Model 75 utilizes five individual sections, each with specific air treatment tasks that are pre-selected, then factory assembled to form a compact, inline, drop-in unit. The modules and their basic functions include:

MODULE NAME	NORMAL FUNCTION
Prefilter/Impinger	Mist Eliminator/Grease Extraction
ESP-Electrostatic Precipitator	High-efficiency Primary or Secondary Filtering Device
Media	Primary, Secondary or Backup Filter
Adsorber	Odor Control and Removal
Blower	System Air Mover

CHARACTERISTICS OF PARTICLES AND PARTICLE DISPEROIDS

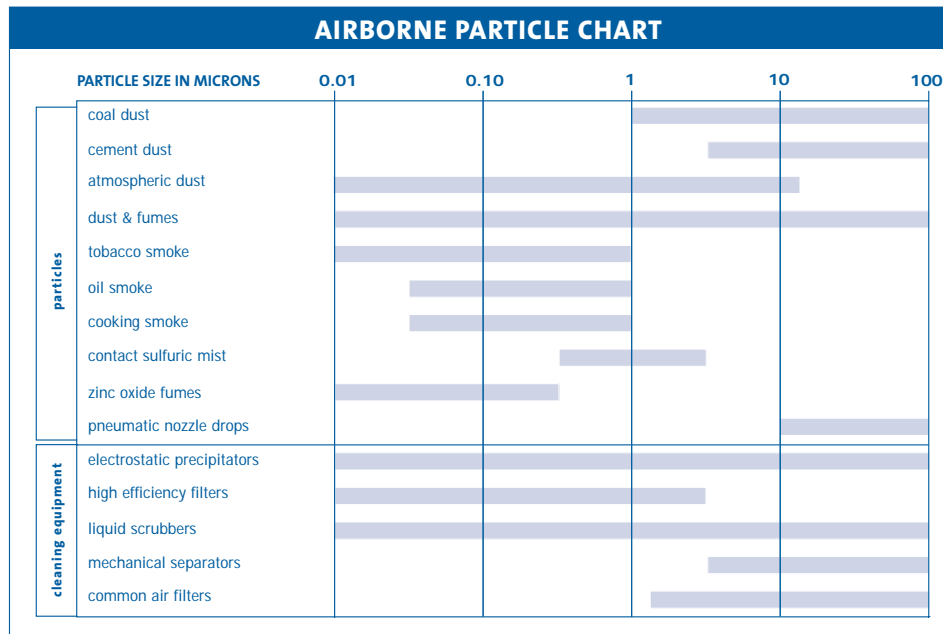

Model 75 Features

FEATURE/BENEFITS

- Customized for specific applications
- Effective on airborne solids, liquids and odors
- Available in various capacity ranges
- Factory assembled, built-up construction
- Integral automatic cleaning system
- Optional fire suppression system
- ETL and UL listed
- Designed for: simplified installation, ease in service, NFPA 96 standards

MODEL 75 APPLICATIONS

Oil Mist:

- Machine Shops
- Cold Heading
- Screw Machines
- Foundry
- Presses
- Machining Centers
- Heat Treating
- Tenter Frames

Smoke:

- Welding
- Presses/Forging
- Curing
- Rubber Manufacturing
- Plasticisers
- Heat Treating

Kitchen Exhaust:

- Grease
- Smoke
- Odors
- Wood-fired Cookers

HVAC:

- Clean Rooms
- Return Air
- Outside/Makeup Air
- Lounges
- Bars
- Smoking Rooms
- Casinos
- Indoor Gun Ranges

- **Trion Quality** The same high quality that Trion provides on ALL of the US Navy submarine fleet since 1947 as a sole supplier of air cleaning equipment to the world's navies.
- **NFPA Qualified** Designed to NFPA 96 standards for kitchen exhaust.
- **ETL Listed** ETL approved to UL standard 867.
- **Sectional Design** Built-up design allows units to be tailored to your exact requirements.
- **Smoke and Odor Control** Components effectively remove both liquid and solid particulate as well as gas and odor.
- **Complete System Design** One central system to effectively treat virtually any application for kitchen or industrial exhaust air.
- **High Efficiency Cleaning** Up to 99% efficient, per DOP or ASHRAE test methods.
- **Spiked Ionizer Design** Eliminates common wire breakage and replacement, as seen in wire and other ionizer cell designs.
- **Heavy Duty Cell Design** The most durable and efficient cell design on the market insures long term performance and reliability.
- **Automatic Cleaning** Programmable Logic Controller (PLC) automates the cleaning process which reduces maintenance costs and insures efficient air cleaning at all times.
- **Simple to Service** Designed for easy serviceability from either side of cabinet, as specified.
- **Optional Fire Suppression** Available on all systems to meet your specific requirements.
- **Ease of Installation** System design makes installation simple and requires no field assembly. Just attach your ductwork, electrical connection and plumbing, and it's done.

TYPICAL SYSTEM ARRANGEMENTS

The Model 75 readily adapts to the various air collection methods.

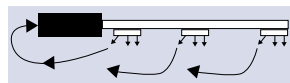

Fugitive Contaminate - Multiple Overhead Discharge through Central Trunk Line



Multiple Source Captured Contaminate Hooded to Main Trunk Line

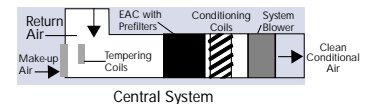

Central System

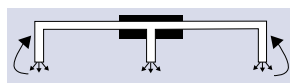

Fugitive Contaminate - Low Column Ducted Discharge

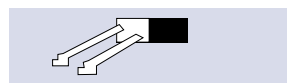

Multiple Source Captured Contaminate Hooded to Common Mixing Plenum

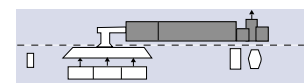

Kitchen Exhaust (Weatherproof)

DESIGN EFFICIENCIES AND OPERATIONAL RELIABILITY



REVOLUTIONARY TECHNOLOGY FOR THE NEW MILLENNIUM

During operation, the contaminated air to be cleaned passes across Trion's unique spiked ionizer blades which are supported between flat grounded electrodes. Revolutionary to the industry, the blades are made of stainless steel that will not rust or break, thus eliminating costly maintenance time and replacement costs.

The DC voltage supplied to the blades creates a high intensity field where the particulate matter in the air becomes electrically charged. The charged particles then pass into a collector plate section made up of a series of equally spaced parallel plates. Each alternate plate is charged with the same polarity as the particles, which repel, while the interleaving plates are grounded, which attract and collect.

Periodically, depending on the type and amount, the contaminate is washed into the cabinet drain basin by an automatic activated integral washing system that is located on both the upstream and downstream sides of the ionizing-collecting cell(s).

A programmable logic controller (PLC) and dual solid-state Pulse Width Modulated (PWM) high voltage DC power supply are housed in a remote-mounted NEMA 12 enclosure. The PLC controls the system functions of wash, fire suppression, and fan on/off. A 7-day clock is standard. The PWM power supply, which energizes the ionizing-collecting cells, comes standard with LED indicator lights. Optional door-mounted meters, which aid in determining cell operating status, are also available.

In applications requiring extremely high collection efficiency and low resistance to air flow, two or three electrostatic sections may be placed inline to create a double or triple pass unit.

DURABLE, COMPACT CABINETRY

When you invest in a Trion Model 75 you want it not only to fit your unique needs, but your individual space as well.

And you want it to last. Trion housings are constructed using 16-gauge zinc-coated steel. Then all welds and the finished area of welds are treated with a corrosion and rust-inhibiting

coating to assure long life. Cabinet finish is completed with a durable industrial grade semi-gloss, baked-on enamel no less than 3 mil thick. All doors are gasketed to prevent air and water leakage. Finally, the housing is furnished completely assembled for easy shipment and installation.

PREFILTER/IMPINGER

The prefilter/impinger track is a standard integral part of the Model 75 ESP cabinet. A 2" rail is positioned upstream of the ESP collector cell to accommodate a standard 40% free area perforated panel for even air distribution, a metal mesh prefilter for light oil mist, or an impinger for more heavy, fluid or semi-fluid particulate matter. The particulate matter may range in viscosities from that of water to relatively heavy greases. In heavy loading applications, the liquid particles strike the impinger, coalesce into droplets and then flow to the drain pan below. If the particles are of a high viscosity nature that do not readily flow into the drain pan, they are periodically flushed down the drain with an optional bolt on collar containing an integral wash system located upstream of the impinger. A similar track, located downstream of the unit, is designed to house a perforated panel and functions as an air distribution device as well as a safety screen like its upstream counterpart.

THE ELECTROSTATIC AIR CLEANER SECTION

Electrostatic Air Cleaner Section enables extremely small particulate matter, "The Fines," to be removed from an air stream with relatively no resistance to air flow. This is due to the open area of the collecting elements. The low resistance is maintained from the start to the completion of the collection cycle. The unit operates in the higher efficiency collection range, upward of 95% DOP Method, on particles ranging in size from 10 Microns down to 0.01 Microns in size.

STANDARD BLOWER PACKAGE

The TEFC energy efficient blower is designed for horizontal air flow and mates with the air purification system to provide a uniform distribution of air. The blower wheel is steel, backward inclined, welded construction.

OPTIONAL UPBLAST BLOWER

The NFPA 96 UpBlast fan is designed to mate with the air purification system and provide uniform air distribution. It is a centrifugal UpBlast exhaust fan, with drain, in compliance with UL 762 for kitchen exhaust applications containing grease-laden air. The blower wheel is steel, backward inclined, welded construction.

SIDE ACCESS FILTER HOUSING

The flexibility of the Media section provides an efficient means for high efficiency filtration, as a prefilter or after filter, depending on your requirement. This section is designed to house a variety of mechanical filters that may be required in your application. The housing allows for various filter combinations that are tailored to your specific needs, such as HEPA's, 95% bags, mini-pleated cartridges or other media. The heavy-gauge dual-access housings are supplied with industrial-grade hardware.

SIDE ACCESS/FINAL FILTER SECTION

Unlike particulate filters, odors in the form of undesirable gases and vapors are most commonly removed from the air stream by the process of adsorption that is enhanced by multi-faceted porous surfaces of certain materials. Filter trays of activated carbon or optional potassium permanganate pellets effectively facilitate the adsorption of these odors and gaseous contaminants.

PRINCIPLE OF OPERATION

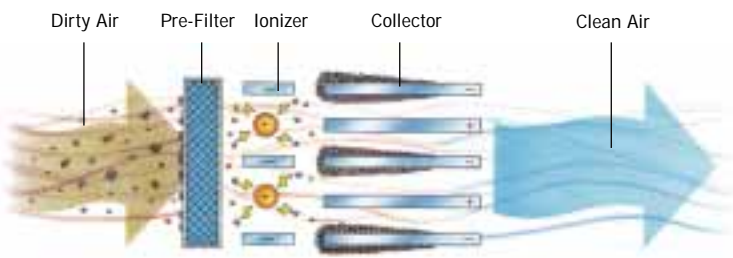

Electronic Air Cleaning

AIR VELOCITY FEET PER MINUTE

Efficiency-Curves 1, 2 and 3

1. Overall DOP (Diocetylphthalate) efficiency using 10 Stage Cascade Impactor
2. ASHRAE Standard 52 Dust Spot Test Method Atmospheric Air
3. 0.3 Micron DOP efficiency using 10 Stage Cascade Impactor

Pressure Drop Across Unit-Curves 4, 5 and 6

4. Cell with 40% open perforated plate front and rear
5. Cell with 1" metal mesh filter front and rear
6. Cell only

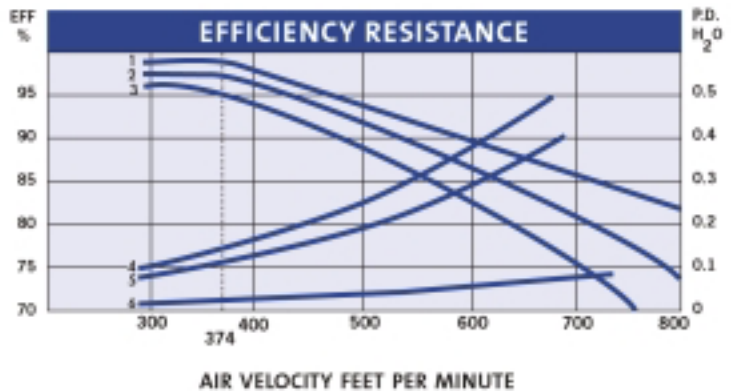

AIRBOSS®

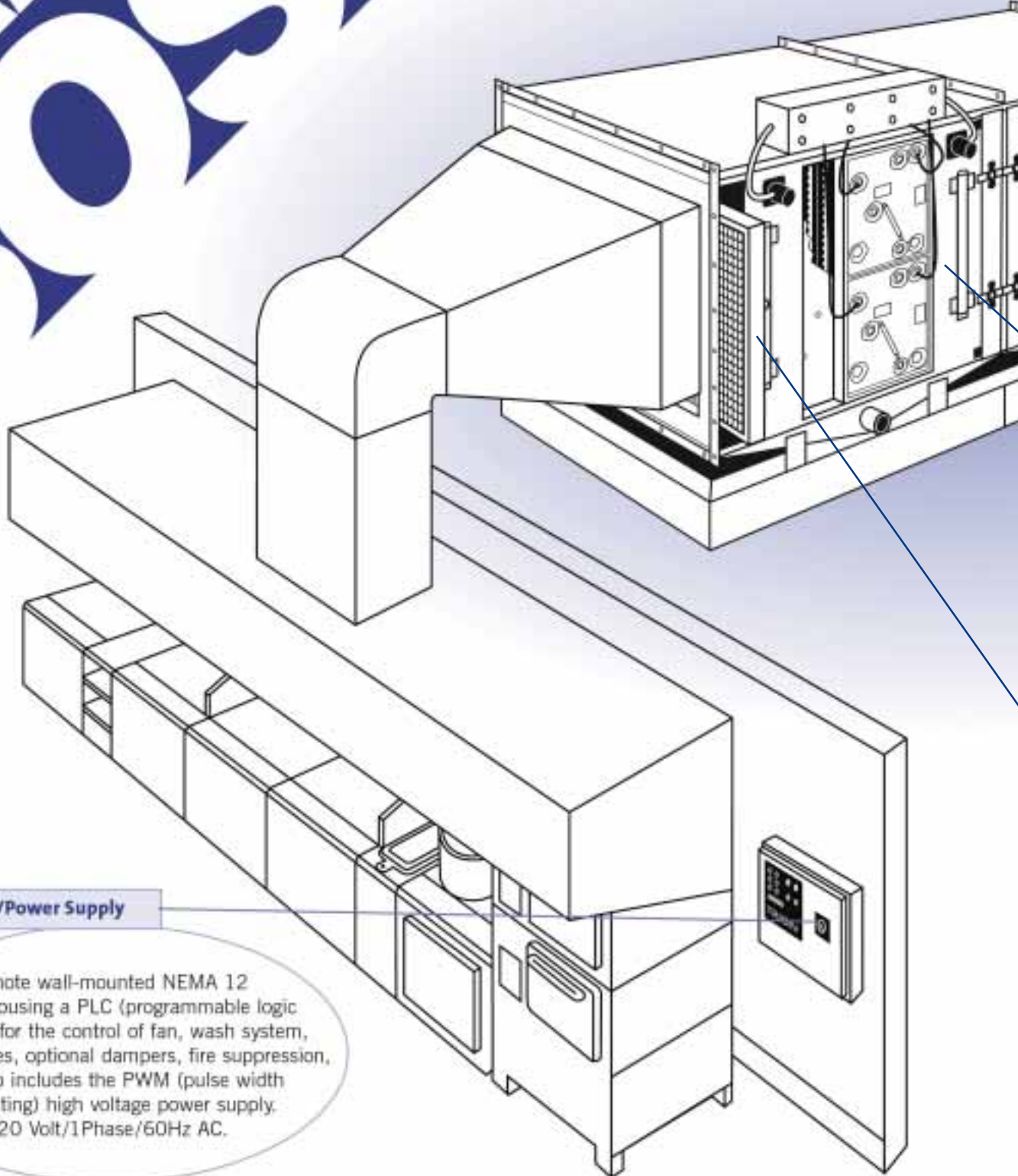

Control/Power Supply

Remote wall-mounted NEMA 12 cabinet housing a PLC (programmable logic controller) for the control of fan, wash system, power supplies, optional dampers, fire suppression, etc. Also includes the PWM (pulse width modulating) high voltage power supply. 120 Volt/1Phase/60Hz AC.

**Kitchen Hood Exhaust
(Smoke, Grease, Odors)**

DUST AIR BOSS[®]

SMOKE SPLIT

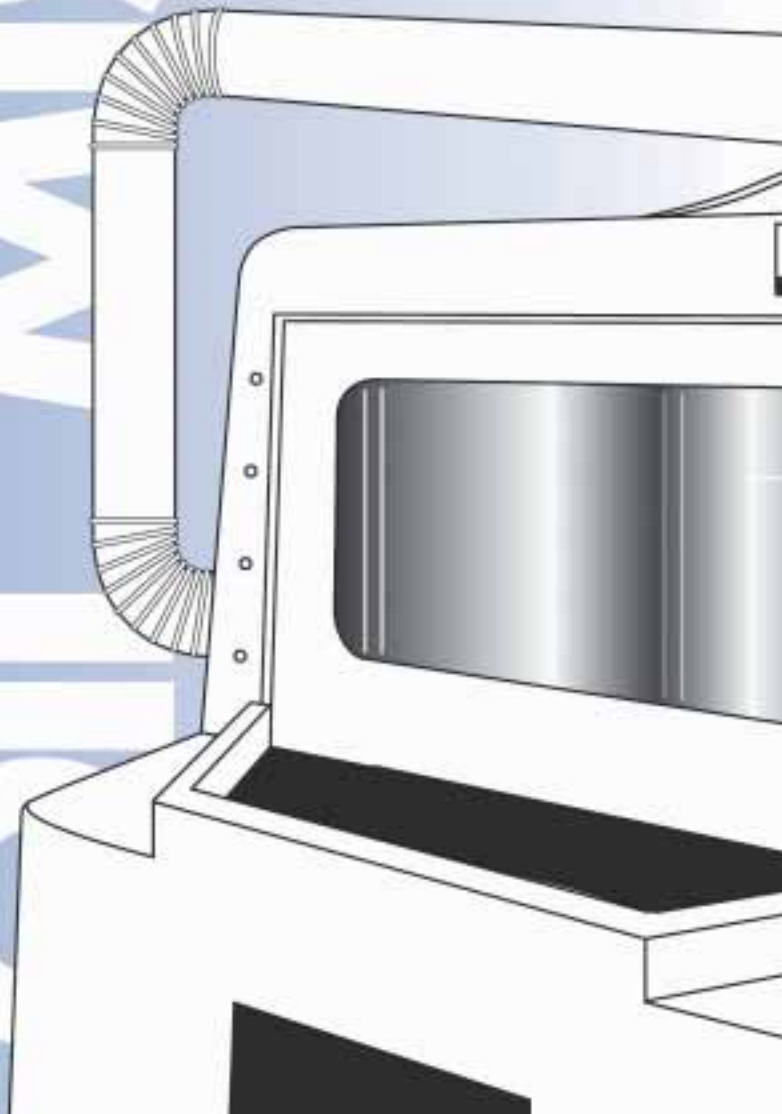

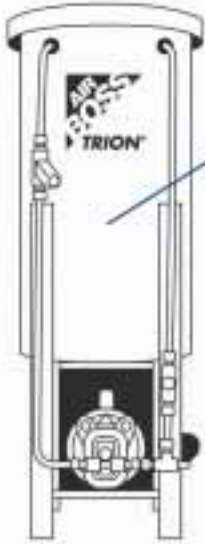

Detergent System

Trion approved concentrated detergents used to clean commercial or industrial applications. Includes: tank (16, 30, 55 gallon sizes), feeder pump, metering valve, strainers and water control valves.

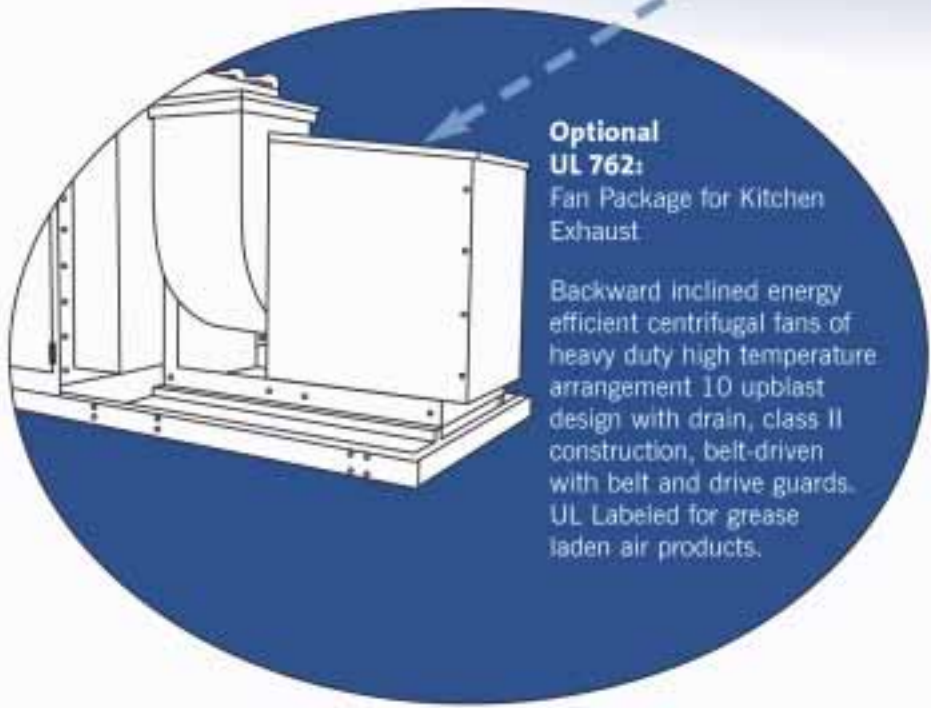
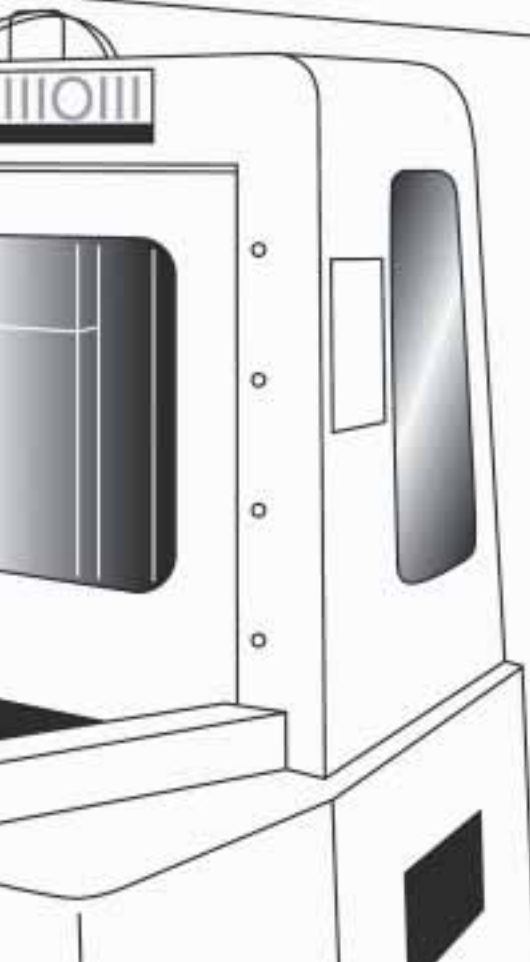
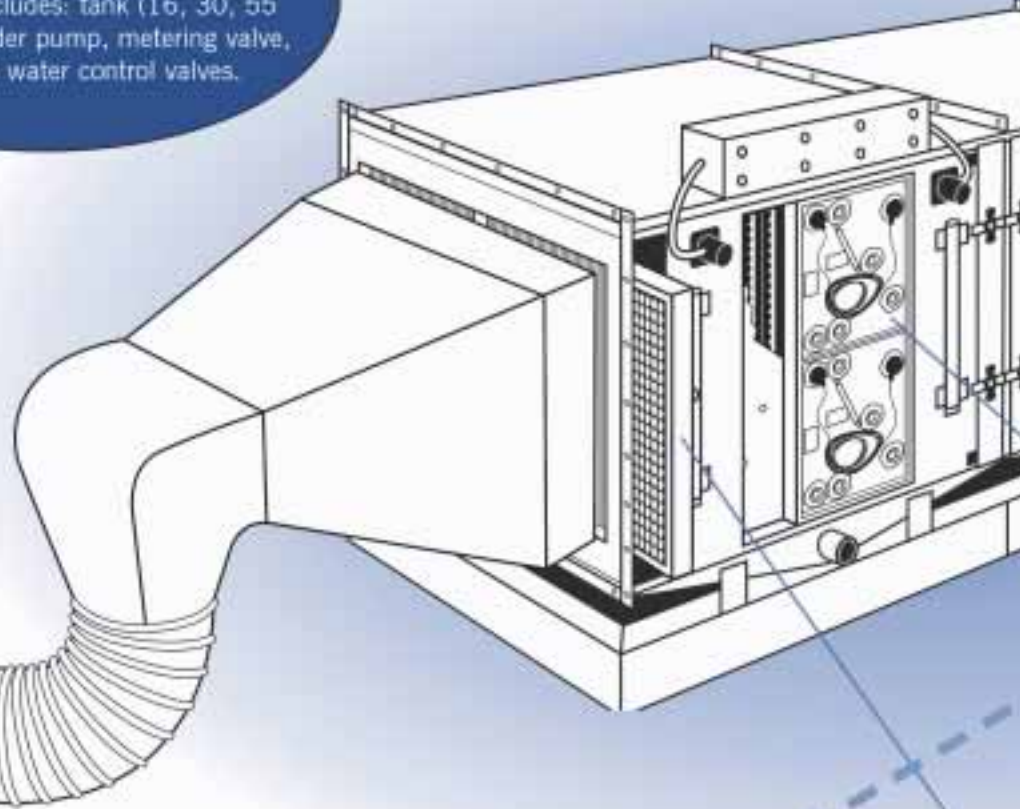

Optional UL 762: Fan Package for Kitchen Exhaust

Backward inclined energy efficient centrifugal fans of heavy duty high temperature arrangement 10 upblast design with drain, class II construction, belt-driven with belt and drive guards. UL Labeled for grease laden air products.

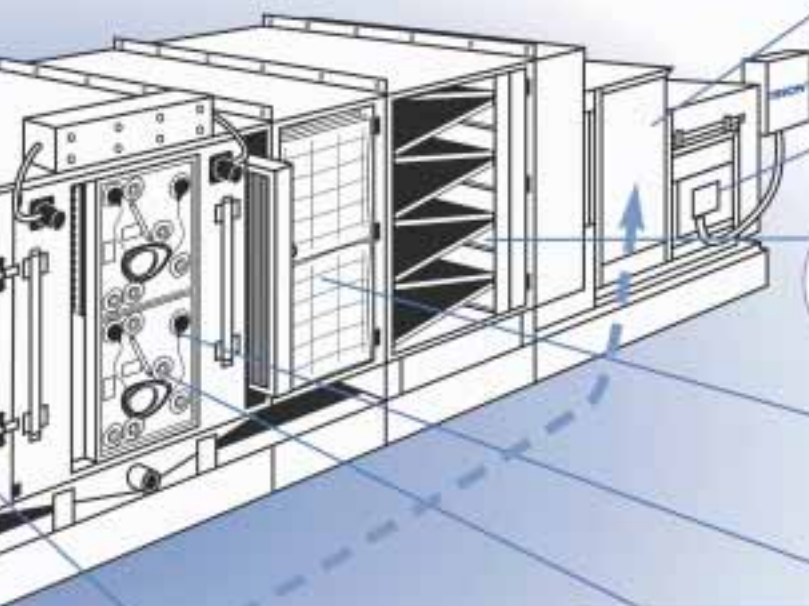

Fan Package

Backward inclined energy efficient centrifugal fans of heavy duty AMCA arrangement 9 inline or arrangement 10 upblast design, class II construction, belt-driven with belt and drive guards.

Fire Suppression Option

Weather tight enclosure includes ADP-S nozzles for the impinger section and electronic air cleaner section.

Adsorber Section

Activated carbon or optional potassium permanganate pellets for gaseous odor adsorption.

Media Section

Designed to house a variety of mechanical filters as required for a specific application, or to insure extended life of the adsorption media.

Spiked Ionizer Blade

Revolutionary technology made of stainless steel blades, not wires. Reliable, unbreakable blades eliminate costly maintenance replacement and downtime.

Ionizing-Collecting Cell

High efficiency multi-stage collection cell, rugged design, to maintain high efficiency under heavy loads.

High-Voltage Stand-Off Insulators

Made of self-glazing ceramic, insulates electrical current; helps to prevent and virtually eliminate arcing, prolong power supply, life span and aid in maintaining high efficiency. Prevents tracking, retards contaminate build-up and provides easy cleaning.

Prefilter/Impinger Section

Metal mesh or perforated plate prefilter for safety and capture of oversize objects and agglomerated mists. Impinger may be used to knock down heavy mists and kitchen grease.

Model 75

AIR PURIFICATION SYSTEMS

*Model 75 Series for Industrial Applications
and Kitchen Hood Exhaust Systems*

MODEL 75 SERIES

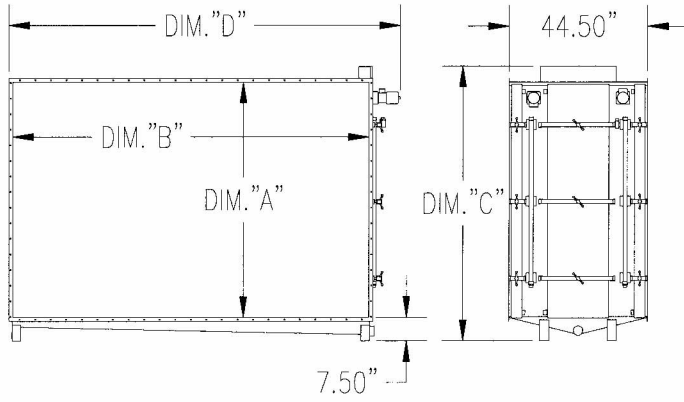

BAG HOUSING

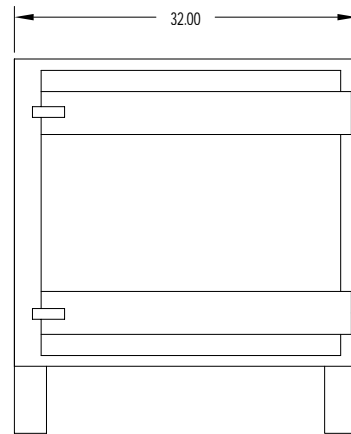
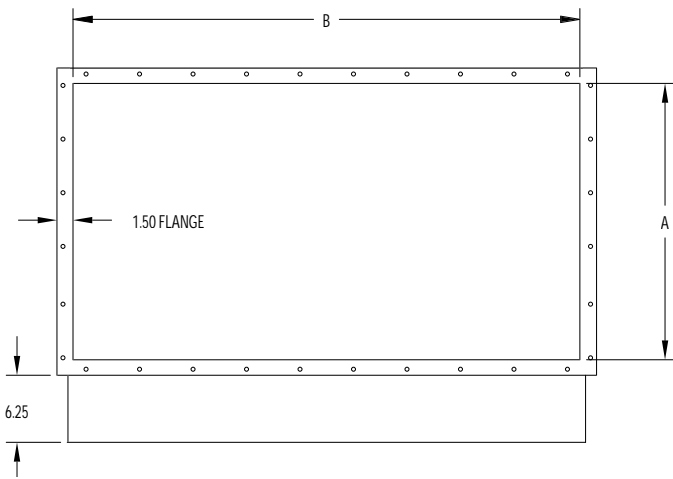

CARBON HOUSING

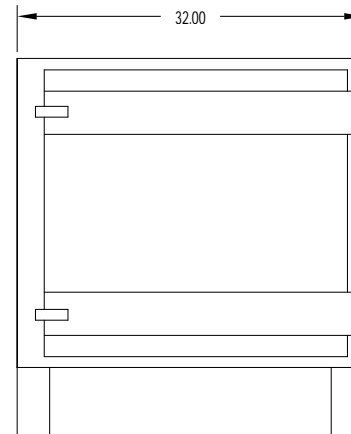
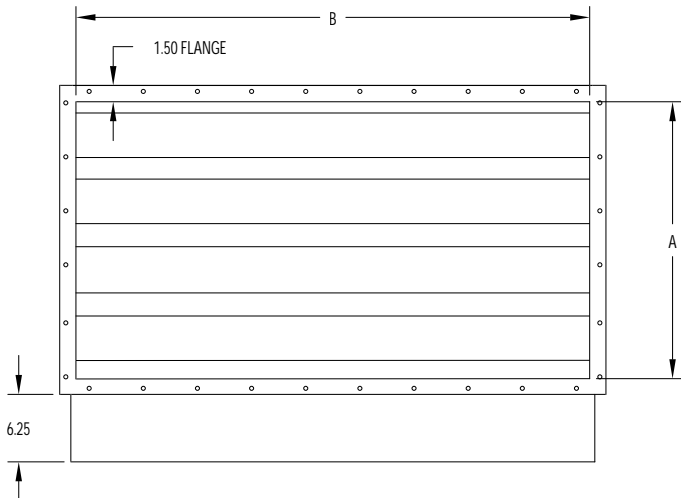

STATIC PRESSURE DROPS



TRION EQUIPMENT LOSSES INCHES H2O

ESP Section	0.14"
40% open perforated prefilter or after filter	0.15"
Metal mesh prefilter or after filter	0.10"
2" impinger	1.25"
Media Section	0.11"
	Initial Final
4" pleated prefilter, 40% efficient	0.17" - 1.00"
10 pocket bag, 65% efficient	0.40" - 1.20"
HEPA, 99.97% efficient	1.00" - 1.50"
Adsorber Section	0.28"
1" trays	0.26"
2" trays	0.28"
4" modules	0.36"
Fan Transition	0.11"

The ESP section must have both an internal prefilter and an after filter, select and add for each.

External losses for ductwork, exhaust hoods, manufacturing equipment with associated entry losses, kitchen hoods, etc., must be added with the above Trion internal equipment losses to calculate total fan static pressure required.

Trion History

PROVIDING CLEAN, COMFORTABLE & SAFE IAQ SOLUTIONS FOR MORE THAN HALF A CENTURY

Since 1947, Trion has manufactured quality products for the commercial, industrial, residential, and military markets. All Trion products are engineered specifically to provide a clean, safe and comfortable indoor air environment. Trion's success has been driven by the dependable performance and superior quality of our products, as well as by our excellent customer service.

Trion's technical expertise allows us to create innovative products and cost-effective, environmentally sound solutions that solve the air cleaning problems of our worldwide customer base. Our products can be found in homes, offices, factories, clubs, hospitals and sea vessels.

Headquartered in Sanford, North Carolina, Trion manufactures products in a dedicated 263,000 square-foot plant. Trion UK's European, Middle East and Far East operations are based in Andover, Hampshire in the United Kingdom.

Trion Deutschland GmbH, formed in 1984, is responsible for serving markets in Central and Eastern Europe.

In 1996, Trion purchased Herrmidifier, a well-known manufacturer of humidification products for use in a variety of commercial, residential and industrial settings.

Trion is part of Fedders Indoor Air Quality, which opened its first Asian manufacturing facility in Suzhou, China, in August 2002.

Today, and in the future, Trion will continue to develop innovative air cleaning solutions that meet the demands of our customers throughout the world .





Headquartered in Sanford, North Carolina

Leading Technology for Cleaner Exhaust Air Since 1947

TRION[®]
Air Purification Systems