

Simplicity®

LIGHT KIT
No. **318**

1963/64
LL.

705018 Hex Capscrew, 5/16-18 x 1 1/2 lg.
717001 Hex Nut, 5/16-18
720001 Lock Washer, 5/16"

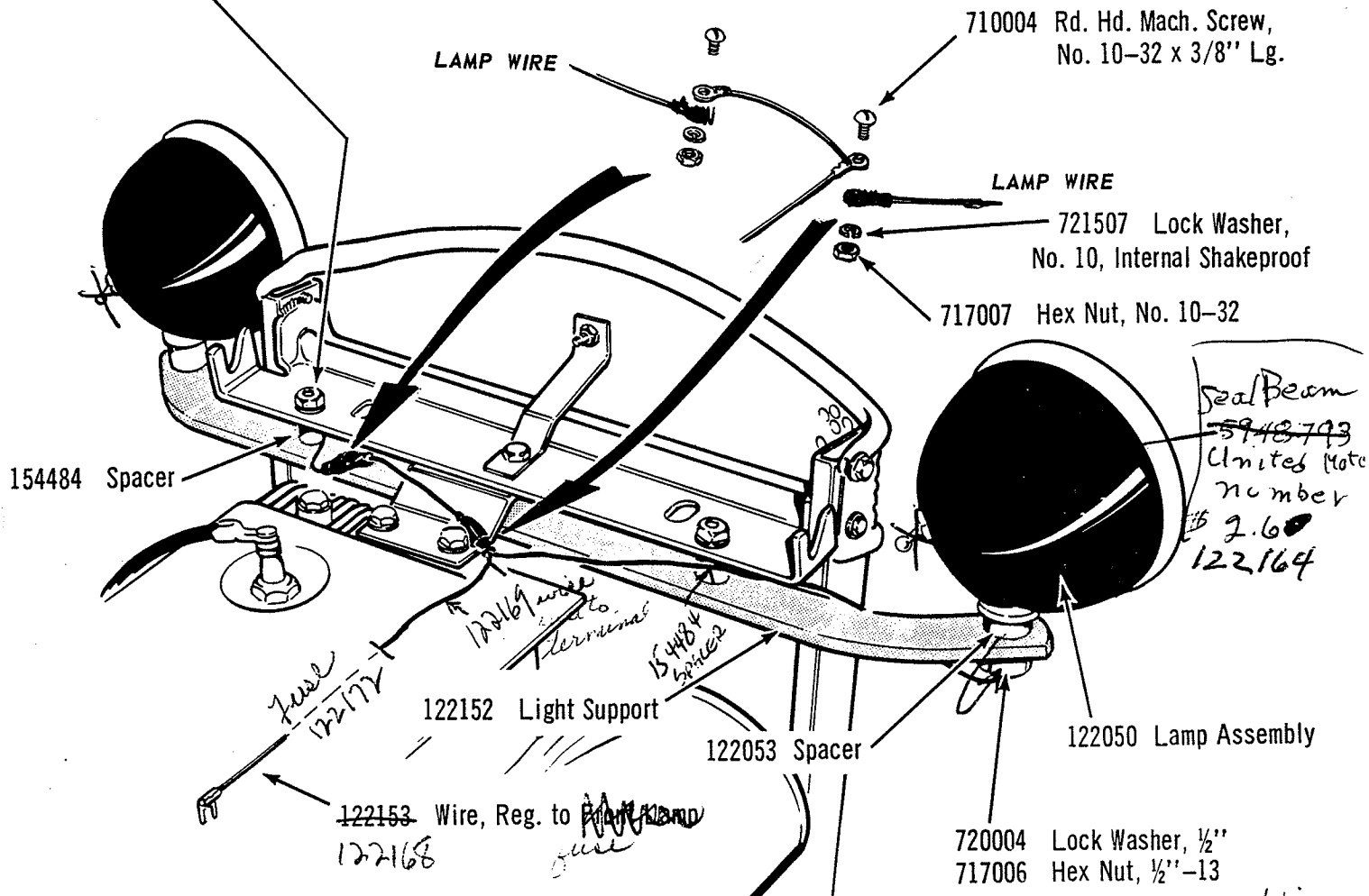

1. Before beginning to install the light kit, study the above illustration and identify all of the parts. Remove the tractor hood, and attach the light support to the tractor at the location shown above. Use two hex capscrews, 5/16"-18 x 1 1/2" Lg. with two 5/16" lock washers and two 5/16"-18 hex nuts and two spacers as shown. Tighten securely.
2. Remove all paint from the immediate area around the two lamp mounting holes on the light support, and mount the lamps to the support with a spacer between the lamp and the support. Fasten securely with a 1/2"-13 hex nut and lockwasher.
3. Attach the ~~terminals~~ ^{ends} of lamp wires to the terminals of the wire furnished with the light kit, using a #10-32 Rd. Hd. Machine Screw with lockwasher and hex nut at both lamp wire terminals. Wrap both connections securely with Electrician's Tape. Connect the spade terminal of the wire to the "BAT" terminal of the voltage regulator.

Chrome Molding
912044 - 2.50
Switch 122165
915041 - 1.60
Screw for Chrome
912048 - .10

Litho in USA

Form MF-56

