



This product is intended to be connected to analogue networks and private switching systems in the United Kingdom.

This product has not been designed for making emergency telephone calls when the power fails. Alternative arrangements should be made for access to emergency services.

PaperJet 55

Plain Paper Fax, Copier, Colour Printer and Telephone

**User
Guide**

**Please open this page for an ‘at a glance’
guide to your PaperJet 55.**

Please open this page for a ‘further at a glance’ guide to your PaperJet 55.

At a glance

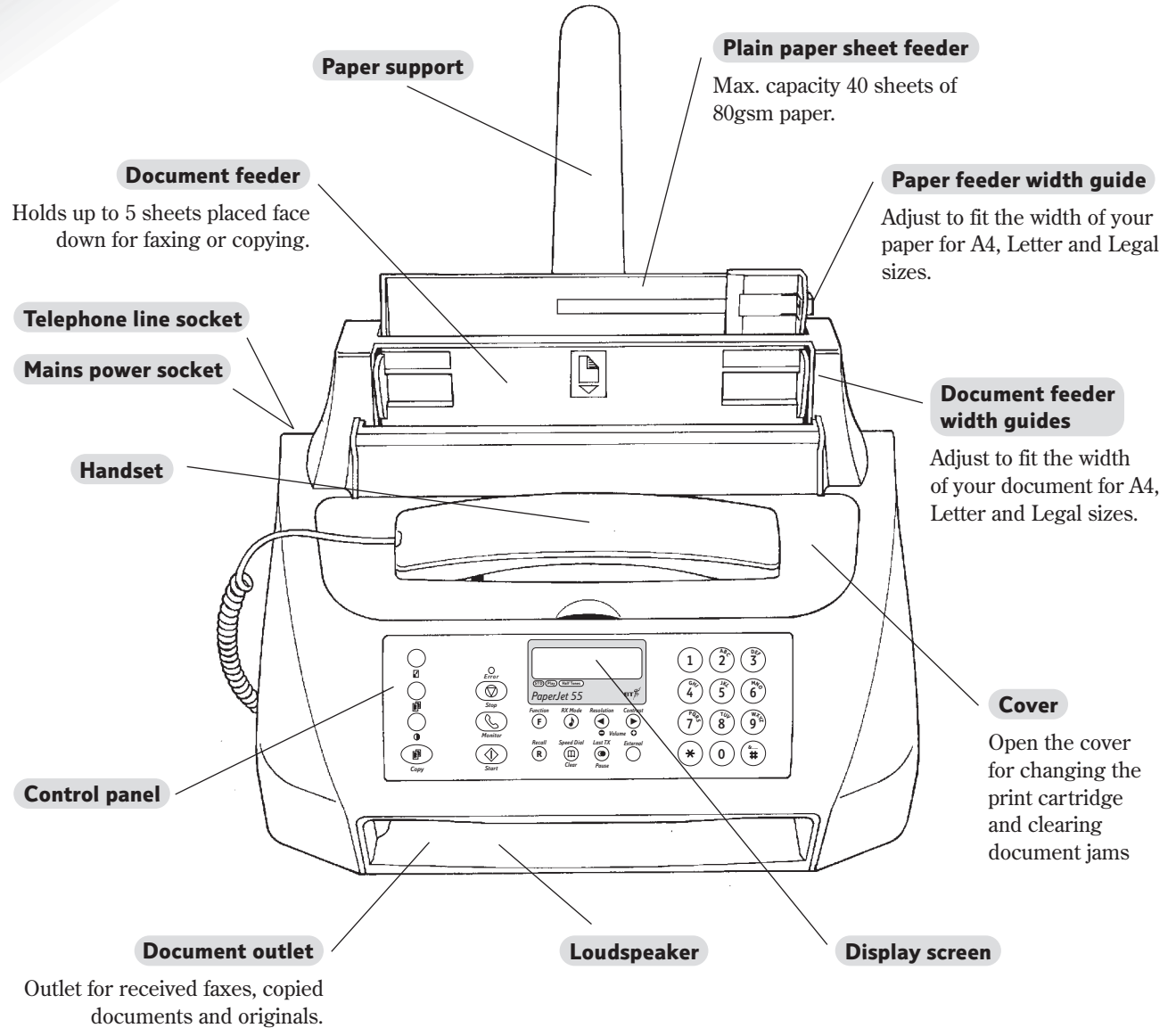

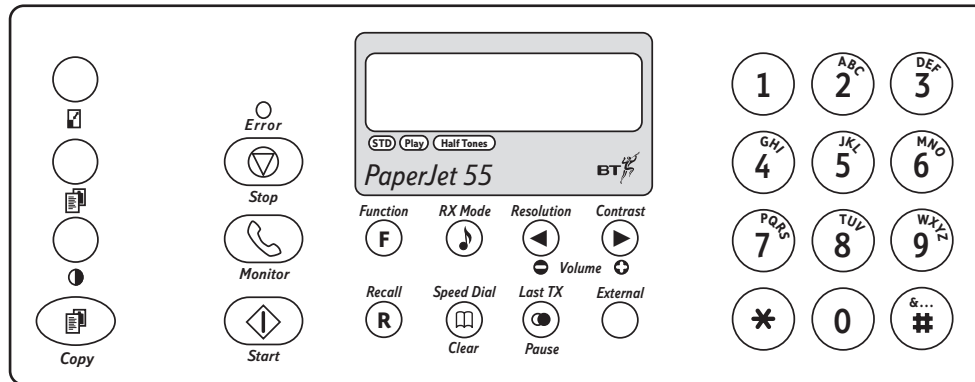

Reduction/Enlargement button. Reduces and enlarges copies to either 70% or 140%.



Resolution button. Allows you to choose text or photo resolution for copies.



Contrast button. Adjusts the contrast of documents to be copied.



Copy



Error

Error light. Indicates a problem when sending or receiving a fax.



Stop

Stop button. Stops the current operation. Returns the fax machine to standby.



Monitor

Monitor button. Press to get dialling tone.



Start

Start button. Press to send a fax. Confirms an option chosen from the menu. During a call, press to receive a fax.

Function



Function button. Function button lets you select options from the menus.



RX Mode

RX Mode/Hold button. Selects reception methods for faxes. When on a phone call, press to put a caller on hold. They hear a beep.

Resolution



Resolution/Volume – button. Adjust the resolution of documents to be faxed. Select next option from a menu.
Decrease loudspeaker volume



Contrast

Contrast/Volume + button. Adjust the contrast of documents to be faxed. Select previous option from a menu.
Increase loudspeaker volume

Recall



Recall button.

Speed Dial



Clear

Speed Dial/Clear button. Used to speed dial a stored number. Deletes incorrect settings and characters.

Last TX



Pause

Last Number/Pause button. Press once to display last number dialled. If you have a document in the ADF it shows the last fax number, if not it shows the last telephone number called. Press again to dial the number displayed. When dialling or storing a number, press to enter a pause.

External



External button. Connects you to an outside line when connected to a switchboard.

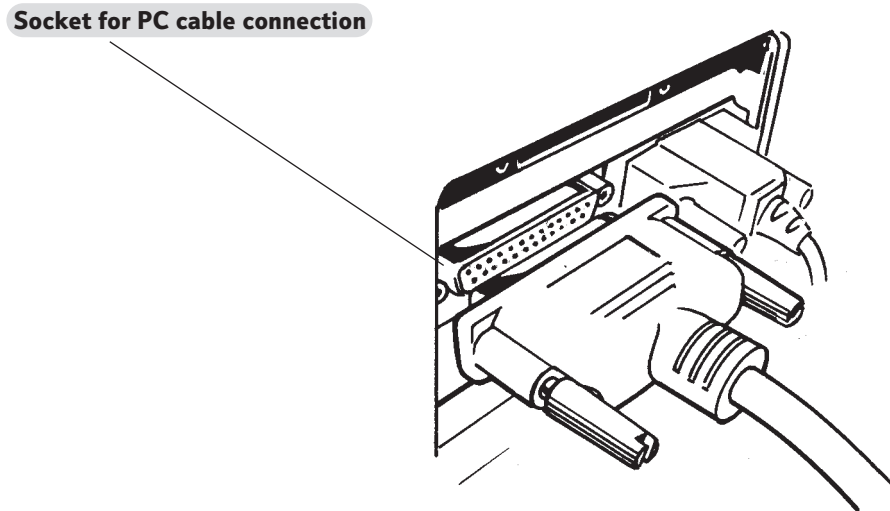
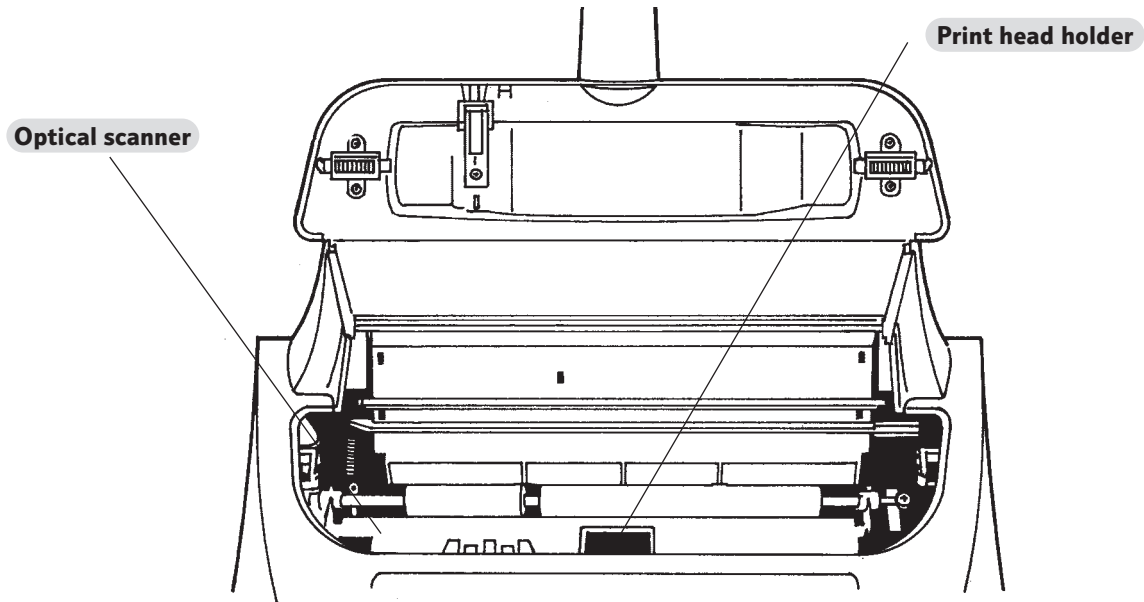

Key features

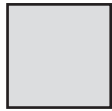

Plain paper fax

Holds up to 40 sheets of A4 paper for ink jet quality printing.



21 page memory

If you run out of ink or paper while receiving a fax the document will be stored in the memory and automatically printed out when the new paper or ink has been added.



Copier with zoom

Make single or multiple copies of documents. Enlarge copies to 140% or reduce to 70%



One touch and speed dial memories

10 one touch memories and 31 speed dial memories can each store a fax number, phone number and name. Easy to display and scroll through the memories.



Mono/colour printer for PC

Print documents from your PC. Interchangeable black and colour cartridges let you print in colour whenever required.

IMPORTANT

To print from your PC

A Bi-directional parallel printer cable is required. To print in colour, a colour ink cartridge is required. These items are not supplied with the machine and must be purchased separately.

In this guide

<i>At a glance</i>	2
<i>Introduction</i>	7
<i>Safety information</i>	8
<i>Setting up</i>	9
<i>Using your PaperJet 55</i>	15
<i>Sending faxes</i>	15
<i>To broadcast a document</i>	19
<i>Using the one-touch memories</i>	21
<i>Using the speed-dial memories</i>	22
<i>Reports and lists</i>	24
<i>Making and receiving phone calls</i>	26
<i>Copying documents</i>	28
<i>Additional features</i>	29
<i>Polling</i>	33
<i>Connecting an answering machine</i>	35
<i>Connecting to a switchboard</i>	37
<i>Help</i>	39
<i>Maintenance</i>	44
<i>Technical information</i>	49
<i>Index</i>	51

Introduction

Unpacking your PaperJet 55

When you unpack you should have:

PaperJet 55 with attached mains power cable and fitted 3-pin plug.



Telephone line cord



Starter print cartridge

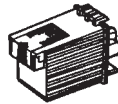

Handset with cord



Paper support



Document holders for use with torn, thin or small pages



CD with PaperJet 55/65 PC software

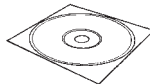

PaperJet 55/65 PC Printing Guide



Cartridge storage container



The following items are not included with your PaperJet 55 but are required for PC printing and printing of colour documents

Printer cable



Colour cartridge



NOTE

Using the PC print facility

Please refer to the separate PaperJet 55/65 PC Printing Guide.

For your records

Date of purchase:

Place of purchase:

Serial number (on base of unit):

Proof of purchase is required for warranty purposes, so please keep your receipt.

Safety information

Never put foreign bodies into the fax machine.
Their accidental contact with powered parts may
cause a fire or electric shocks.

Do not expose to direct sunlight.

Do not stand your fax machine on carpets or other
surfaces which generate fibres, or place it in
locations preventing free flow of air over its surfaces.



Do not submerge any part of your fax
machine in water and do not use it in damp
or humid conditions such as bathrooms.



Do not expose your fax machine to fire,
explosive or other hazardous conditions.



There is a slight chance that your fax
machine could be damaged by an electrical
storm. We recommend that you unplug the
power and telephone line cord for the duration of
the storm.

Setting up

1 Plan the location of your PaperJet 55

Place your PaperJet 55 on a stable, flat surface. Make sure it is close enough to the telephone and mains power sockets so that cables will reach.

Remember to leave enough room at the front of the machine for documents to come out. Allow a free flow of air around the machine for ventilation.

2 Fit the paper support

Fit the plastic support into the slot at the back of the machine. Ensure it clicks firmly into place.

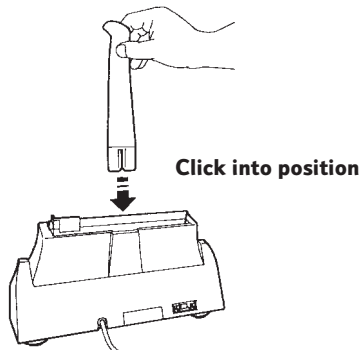

3 Connect the handset

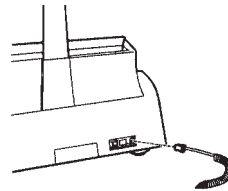

Plug the handset cord into the socket marked  at the back of the machine.

Place the handset in the cradle.

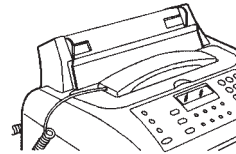

4 Connect the telephone line cord

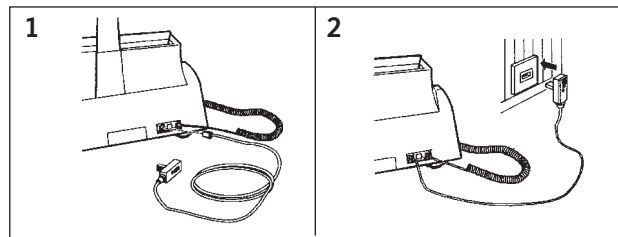

1 Plug the telephone line cord into the socket marked **LINE** at the back of the machine.

2 Connect the other end to the telephone wall socket.

NOTE

The socket in the back of the line plug is for line connection of an answering machine.

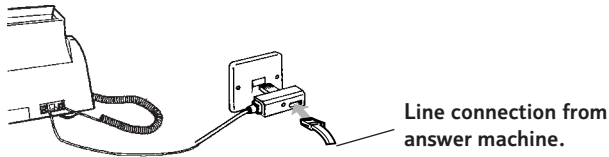

5 Connect the mains power

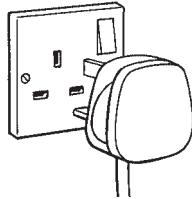

Plug into the mains power and switch on.
Your PaperJet 55 performs a quick self-test.
The display shows:

AUTOMATIC RX
CHECK PRINT HEAD

IMPORTANT

Before connecting your PaperJet 55 to your PC, complete these setting up instructions.

6 Load paper

The plain paper sheet feeder can hold up to 40 sheets of 80gsm paper.

It can accommodate A4 (210 x 297mm), US Letter (216 x 279mm), and US Legal (216 x 356mm) and weights between 70-90gsm.

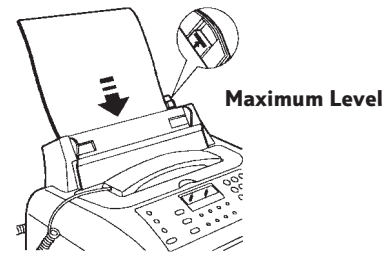

Place the paper in the sheet feeder. Do not force it in.

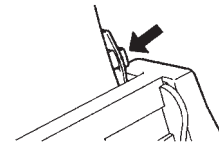

Use the paper width adjustment lever to push the paper against the left side of the feeder.

NOTE

When you need to add more paper, always slide it under the paper that's already loaded.

7 If necessary, check the paper size setting

Your PaperJet 55 is preset to use standard A4 paper. If you need to use a different size you will need to change the setting as shown below.

To ensure your PaperJet is set to print on the paper size you are using, check the print format setting.

Function
F

Press the **Function** button until the display shows FAX SET UP

Start

Display shows DATE AND TIME

Function
F

Press the **Function** button until the display shows PRINTER PARAMET

Start

Display shows SIZE: A4

Volume

Press until the display shows the paper size you want.

Start

To confirm the setting displayed.

Stop

Display shows
AUTOMATIC RX
CHECK PRINT HEAD

8 Install the starter print cartridge

Open the printer compartment cover.

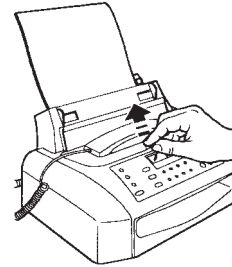

Remove the print cartridge from its packaging. Holding it by the finger grip, peel the protective film from the print nozzles.

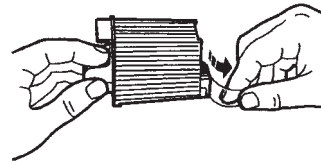

Avoid touching the nozzles and metal electrical contacts.

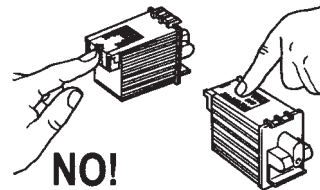

Insert the cartridge into the holder with the electrical contacts facing towards the front of the machine.

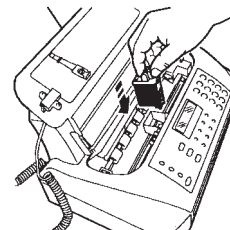

Pull the cartridge towards the front of the machine until you hear it click into position.

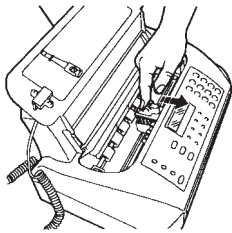

Close the cover.

If the display continues to show CHECK PRINT HEAD the cartridge may not be installed properly. Open the cover and check that the cartridge is correctly orientated and clicked into position.

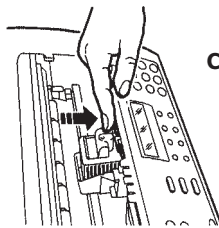

Click into position

NOTE

To replace the cartridge when it runs out of ink, follow the instructions in the Maintenance Section on page 44.

Should the message persist, you may need to clean the electrical contacts and the carriage (see 'To clean the print head', page 46).

9 Automatic print quality test page

Your PaperJet 55 automatically cleans the print nozzles and prints a test page. Once printed, the display shows

```
CHECK PRINT OUT
1 = EXIT 0 = REPEAT
```

The printed sheet contains the following:

- a **numbered scale**, to check ink flow and the electrical circuits on the print head.
- a set of **graphics and text** to assess print quality.

Check the numbered scale **for interruptions and the black areas for horizontal white lines**. If none are present, the print head is installed correctly and working normally.

- 1 Press **1** if the test print is acceptable.

Or

- 0 Press **0** to repeat the test.

If there is still a problem after printing three test pages try:

- changing the paper you are using, it may be too porous.
- removing and re-installing the print cartridge.
- cleaning the electrical contacts and print nozzles (see 'To clean the print head', page 46).
- replace the print head.

10 Set the date and time

The current date and time will be printed on every fax page you send.



Press the **Function** button until the display shows FAX SET UP



Display shows DATE AND TIME



Display shows FORMAT: DD/MM/YY

You can select a different format by pressing the < > buttons.



Display shows FORMAT: 24H



Press the < > buttons to switch between the 24 hour clock and the 12 hour clock formats.



Display shows DD/MM/YY HH:MM
21 06 00 09 22

The cursor flashes on the first digit of the date.



Enter the new date and time. Each time you enter a digit the cursor moves on automatically.



Press the < > buttons to move the cursor backwards and forwards if you need to re-enter a digit.

NOTE

If you have selected the 12 hour clock, the letter P for pm or A for am is displayed. To display the correct P or A setting, press the FUNCTION button when the cursor is flashing on the P or A.



Press to confirm the new date and time.



To return to standby.

NOTE

You can stop any procedure and return your PaperJet 55 to standby at any time by pressing STOP.

If you do not press any button on your PaperJet 55 for 2 minutes it will automatically return to standby.

11 Enter your name and fax number

Your name and number will be added to every fax page you send. You can enter a maximum of 16 characters and 20 digits.



Press the **Function** button until the display shows INSTALLATION



Display shows TEL. LINE SET-UP



Press twice. Display shows STATION NAME



Display shows TYPE YOUR NAME



Press the buttons to enter your name up to a maximum of 16 characters.



Press the < > buttons to move the cursor to the character you want or to insert a space.



Press the * and # buttons to enter different symbols such as '&'.



Press the **Clear** button to delete entries.



For example to enter the name JOHN:



Press the **5** button until the display shows J.



Press >



Press the **6** button until the display shows O.



Press >



Press the **4** button until the display shows H.



Press >



Press the **6** button until the display shows N.

When you have finished entering your name



To confirm. Display shows PHONE NUMBER



Display shows TYPE YOUR NUMBER



Enter your phone number.

If you are entering your number in an international format press the ★ button to enter a +.



Press to confirm.



To return to standby.

To set the position of your fax header

Your name, fax number, date and time can be shown at the top of the page outside the text area or slightly lower down inside the text area. The default setting is for the header to be shown inside the text area. You can switch between these two positions.

Function



Press the **Function** button until the display shows FAX SET-UP



Display shows DATE AND TIME

Function



Display shows VARIOUS SETTINGS



Press until the display shows HEADER INSIDE

Your header will be printed inside the text area.



Press to display INSIDE or OUTSIDE.



To confirm the displayed option.



To return to standby.

NOTE

Connecting to your PC

Please follow the steps shown in the separate PaperJet 55/65 PC Printing Guide.

Using your PaperJet 55

Sending faxes

What type of paper you can use

Dimensions:

- width 148mm – 216mm.
- length 216mm – 600mm.

Thickness:

- 60-90gsm max 5 sheets.
- 50-140gsm 1 sheet at a time.
- 140-160gsm when using the document holders.

Do not use

- Torn, crumpled and rolled paper.
- Paper that is too thin (unless in the document holder supplied).
- Wet or moist paper.
- Carbon paper.
- Correction fluid, paperclips and staples.

Inserting documents in the feeder

- Gently insert documents to be faxed (up to 5 pages) face down.
- Adjust the paper feeder width guides to fit.

Setting the contrast and resolution

You can choose different resolution and contrast settings to ensure the best quality when faxing or copying a document.

Setting the contrast and resolution

After inserting the document in the feeder.

Contrast



Press the **Contrast** button.

To select the setting you want.

- **NORMAL** – when the original document is clearly printed.
- **DARK** – when the original document is light.
- **LIGHT** – when the original document is dark.

After the fax has been sent, your PaperJet always resets to normal contrast.

Resolution



Press the **Resolution** button.

To select the setting you want.

- **STD** (standard) – when the original contains easy to read text.
- **FINE** – when the original contains small or hard-to-read text or line diagrams.
- **FINE** and **HALF-TONE** – when the original contains varying shades of grey or pictures.

NOTE

FINE and HALF-TONE settings take longer to send.

To select the default resolution setting

Your machine is pre-set to STD resolution for faxing and copying. You can change this setting so that the resolution is automatically set to FINE.

When the machine is in standby

Function



Press until the display shows FAX SET-UP



Start

To display DATE AND TIME

Function



To display VARIOUS SETTINGS



Start

Press until the display shows TX RESOL. STD



To switch between **FINE** and **STD**.



Start

To confirm.



Stop

To return to standby.

To send a fax

Place document face down in the document feeder.

If necessary set the Contrast and Resolution settings.



Use the keypad to dial the number you want.



Start

Press the **Start** button. The number is dialled before your fax is scanned and sent.

When the fax has been sent, the display shows TX COMPLETED to confirm a successful transmission.

NOTE

*If you make a mistake when entering a number, press the < > buttons to move the cursor over the digit and enter the correct digit. To delete the whole number press the **Clear** button.*

NOTE

*All dialling is shown using **0-9** keypad. You can also use one-touch or speed dialling if they are set.*

To dial and hear the progress of your fax call

Place document face down in the document feeder.

If necessary set the Contrast and Resolution settings.



Monitor

Press the **Monitor** button. You hear the dialling tone over the loudspeaker.



Use the keypad to dial the number you want.



Start

When you hear the far end machine respond press the **Start** button. Your fax is scanned and sent.

When the fax has been sent, the display shows TX COMPLETED to confirm a successful transmission.

To dial using the handset

Place document face down in the document feeder.

If necessary set the Contrast and Resolution settings.

Pick up the handset and listen via the earpiece.

 Use the keypad to dial the number you want.

If the other person's fax machine is set up for automatic reception, you hear the fax tones, press the **Start** button and replace the handset. Your fax is scanned and sent.



If your call is answered in person, ask them to press the start button on their fax machine. You will then hear their fax tones.



Press the **Start** button and replace the handset. Your fax is scanned and sent.

When the fax has been sent, the display shows TX COMPLETED to confirm a successful transmission.

NOTE

To stop a fax being sent at any time, press the Stop button.

To redial the last number



Press the **Last Number** button twice.

Automatic re-dialling

If a fax fails to be sent, for example, the number dialled was engaged, your PaperJet 55 will automatically retry up to 3 times at 2 minute intervals.

If after all retries, the fax has not been sent, the document will be deleted from memory (if using MEMORY TX) or remain in the sheet feeder. You have the option of retaining failed MEMORY TX faxes in memory to enable you to try sending them again without re-scanning. To do this you must enable the document retransmission feature.

To switch document retransmission on/off

The default setting is off.



Press the **Function** button until display shows FAX SETUP



Press the **Start** button. Display shows DATE AND TIME



Press the **Function** button. Display shows VARIOUS SETTINGS



Press the **Start** button until display shows RETRANS.DOC: OFF



Press the < > buttons to switch between **ON** and **OFF**.



Press the **Start** button to confirm the option displayed.



The machine returns to standby.

To send a fax at a pre-set time (delayed faxing)

You can set your PaperJet 55 to send a fax at a specific time in order to take advantage of cheaper call rates or to allow for different time zones.

Place document face down in the document feeder.

If necessary set the Contrast and Resolution settings.

Function



Press until the display shows DELAYED TX



Press the **Start** button.

Display shows TYPE TIME
HH:MM

*If using the 12 hour clock, press the **Function** button to switch between **a** for AM and **p** for PM.*

Press the < > buttons to move the cursor.

0-9

Enter the time at which you want your fax to be sent, e.g. **18.30**.



Display shows TYPE FAX NUMBER and NUM/TOUCH/SPEED.

You can enter a number using the keypad, one touch or speed dial memories. For one touch, press the appropriate keypad button until the entry appears in the display. For speed dial, press speed dial followed by Code No. Refer to pages 21 to 23.

1 2 3

Enter the number you want.



Press to confirm. Display shows the time at which the fax is due to be sent

AUTOMATIC RX
TX AT 18:30

NOTE

*To cancel your pre-set fax transmission, press the **Stop** button or remove the document from the document feeder.*

If you want to store the document in memory for delayed faxing, see “To fax from memory” on page 19.

To change the details of a pre-set fax

You can set a new time and fax number.

Function



Press until the display shows DELAYED TX



Display shows ALREADY ENTERED



Display shows CHANGE PARAM?

Either



Press to display CANCEL SETTING



To confirm. The fax is cancelled and your machine returns to standby.

Or



Display shows TYPE TIME

0-9

Enter the new time at which you want your fax to be sent, e.g. **19.00**



Display shows TYPE FAX NUMBER



Press to confirm. Display shows

AUTOMATIC RX
TX AT 19.00

To broadcast a document

You can set your machine to send a document to up to 10 different numbers (broadcasting).

See “*To fax from memory*” below.

To fax from memory

Your PaperJet 55 has a memory which lets you store one document for sending at a pre-set time.

Place document face down in the document feeder.

If necessary set the Contrast and Resolution settings.

Function



Display shows TX FROM MEMORY



Start

The document is scanned into the memory.
Display shows STORING then TYPE TIME
HH:MM

*If using the 12 hour clock, press the **Function** button to switch between **a** for AM and **p** for PM.*

Press the < > buttons to move the cursor.



Enter the time at which you want your fax to be sent, e.g. **18.30** or press the **Start** button to select the current time.



Start

Display shows TYPE FAX NUMBER



Use the keypad to dial the number you want.



Start

Display shows TYPE FAX NUMBER. If required, enter the second number to which you want to send your fax and press the **Start** button again.



Start

Display shows TYPE FAX NUMBER.

Repeat the last step until you have entered all the numbers you want up to a maximum of 10.



Start

After entering your last number press **Start** again to confirm. Display shows TX SET then AUTOMATIC RX (or current receive mode) and MEMORY TX.

To change, re-send or cancel a stored document

When you have stored a document in the memory for sending later:

Display shows AUTOMATIC RX
MEMORY TX

Function



Display shows TX FROM MEMORY



Start

Display shows ALREADY ENTERED



Start

Display shows PRINT SETTING?



Volume

Press to switch between this and the other two options CHANGE PARAM? or CANCEL SETTING?



Start

Press to select the option displayed.

PRINT – you get a print out of the fax details and then the machine returns to standby.

CANCEL – the machine cancels the memory setting and returns to standby.

CHANGE PARAM? – you can change the fax number and time settings. Display shows TYPE TIME.

0-9

Change the time if required.



Display shows TYPE NUMBER and the number already entered.

0-9

You can change the number if required.

Repeat the 2 steps above for all the numbers that have been entered.



Display shows TYPE FAX NUMBER.

0-9

Enter a new number if required.

Repeat the last step until you have entered all the numbers you want up to a maximum of 10.



After entering your last number press **Start** again to confirm. Display shows AUTOMATIC RX (or current receive mode) and MEMORY TX.

Receiving faxes

RX Mode



By pressing the **RX MODE** button you can set your PaperJet 55 to receive a document in four different ways:

Press to display the following settings.

AUTOMATIC RX – This is Automatic reception. Your fax machine automatically answers fax calls (this is the default setting).

TAD FAX – This is the receive mode to use if you want to use your machine in conjunction with a telephone answering machine to enable you to take fax and voice messages.

MANUAL RX – This is Manual reception. You answer calls in person and receive faxes by pressing the Start button if you hear the fax tones.

PHONE/FAX RX – This is Automatic reception with call recognition. After the set number of rings (default 2), your fax machine will answer the call. If it is a fax, it is received. If it is a voice call the machine beeps for up to 20 seconds and the display shows LIFT HANDSET. If you do not lift the handset the machine prepares to receive a fax.

If you pick up the phone before your machine takes the call and you hear fax tones, press the **Start** button to begin reception and hang up the handset.



Using the one-touch memories

Using the keypad to enter names and numbers

The keypad lets you type letters when you are asked to enter a name.

For example to enter the name JOHN:



Press the **5** button until the display shows J.



Press **>**



Press the **6** button until the display shows O.



Press **>**



Press the **4** button until the display shows H.



Press **>**



Press the **6** button until the display shows N.



Press **>**



Press the ***** and **#** buttons to enter different symbols such as '&'.



Press the **<** **>** buttons to move the cursor to the character you want.



To delete the number or name you have entered completely, press the **Clear** button.

To store a one touch entry

Using the codes 0-9, your PaperJet 55 has 10 one-touch memories under which you can store a name, fax number and telephone number.

You can store numbers up to 52 digits long, and names up to 16 characters long, in each one-touch memory.

Function



Press until the display shows **FAX SET-UP**



Display shows **DATE AND TIME**

Function



Press until the display shows **ONE TOUCH DIAL**



Display shows **TYPE ONE TOUCH**



Enter a single digit **0-9** to set the one touch memory location under which the name and number will be stored, e.g. **1** Display shows **FAX NO.**



Press to switch between **FAX** or **TEL NUMBER.**



Press to select the fax or phone number setting you want.

Display shows **1: FAX or TEL NUMBER.**



Enter the number you want to store. If necessary, press the **<** **>** buttons to move the cursor.



Press to confirm. Display shows **1: NAME**



Enter the name you want to store.



Press the **<** **>** buttons to move the cursor.



Press to confirm. Display shows **EDIT ANOTHER? YES**

If you stored a fax number you can now add a phone number to the memory or vice versa. You can also create a new memory entry.



Press to return to standby

Or



Press to enter another name or number.

Repeat the procedure above to enter names and numbers.



Press to confirm your last entry.



Press to return to standby. Your entries have been stored.

To edit or delete a one-touch entry

Follow the steps shown above to store a one touch entry selecting the location you want to change or delete. A new name and number will overwrite the existing entry selecting the location you want to change or delete.

To edit an entry , press the < > buttons to move the cursor over the digit or character you want to change and enter the correct one.

To delete a name or number, press the **Clear** button when the name or number is displayed during these steps.

Speed Dial



Clear

To send a one-touch fax

Place document face down in the document feeder.

If necessary set the Contrast and Resolution settings.

0-9

Press and hold the **0-9** memory location number for one second. The name is displayed and then the number is displayed and dialled.

Using the speed-dial memories

To store a speed dial entry

Using the codes 01 – 32, your PaperJet 55 has 32 speed dial memories under which you can store a name and fax number and telephone number.

You can store numbers up to 52 digits long in each speed dial memory and names up to 16 characters.

Function



Press until the display shows FAX SET-UP



Display shows DATE AND TIME

Function



Press until the display shows CODED SPEED DIAL



Display shows TYPE SPEED NO.

01-32

Enter the two digit speed dialling code under which the name and number will be stored, e.g. **01**. Display shows FAX NO.

 Press to switch between FAX or TEL NUMBER.



Press to select the fax or phone number setting you want.

Display shows 1: FAX or TEL NUMBER.



Enter the number you want to store.
If necessary, press the < > buttons to move the cursor.



Press to confirm. Display shows 1: NAME



Enter the name you want to store.



Press the < > buttons to move the cursor.



Press to confirm. Display shows EDIT
ANOTHER? YES

If you stored a fax number you can now add a phone number to the memory or vice versa. You can also create a new memory entry.



To return to standby

Or



Press to enter another name or number.

Repeat the procedure above to enter names and numbers.



Press to confirm your last entry.



Press to return to standby. Your entries have been stored.

To edit or delete a speed dial entry

Follow the steps shown above to store a speed dial entry. A new name and number will overwrite the existing entry.



To edit an entry, press the <> buttons to move the cursor over the digit or character you want to change and enter the correct one.



To delete a name or number, press the Clear button when the name or number is displayed during these steps.

To send a speed dial fax

Place document face down in the document feeder.

If necessary set the Contrast and Resolution settings.



Press the speed dial button. Display shows
FAX CALL
CODE OR < >

01-32 Enter the memory location number under which the fax number is stored. The number is dialled.

Or



Press to scroll through fax numbers until the one you want is displayed.

And



The number is dialled.

Reports and lists

Your PaperJet 55 prints the following reports

Power failure report

Always printed automatically.

- if a power failure occurs while a fax is being sent or received the report gives you details about that fax.
- if a power failure occurs before sending when a document has been stored in the memory, or after a fax has been received into memory and not printed out, the report details the number of pages lost from the memory and the date and time of power failure.

Activity report

Provides details of the last 42 faxes sent and received. The report is printed automatically and you can request an activity report at any time.

Transmission report

Provides confirmation of the results of the last fax sent. You can set your PaperJet 55 to print a last transmission report after every fax, every failed fax, or upon request. The default is every failed fax.

Broadcasting report

Contains details about the last broadcast fax sent (see page 25). It is printed automatically after each broadcast fax. You can switch this setting off. The default is ON.

Delayed transmission report

This is a report that is printed automatically when you set a delayed transmission. It gives the number dialled and the time of the transmission. The default is OFF.

What the report terms mean

Reports contain the following information:

Act. n.	Each fax sent and received is given a number.
Type	The type of operation: TX, TX ECM, TX POLL, TX POLL ECM for faxes sent. RX, RX ECM, RX POLL, RX POLL ECM for faxes received.
Doc. N.	Reference number of document stored in the memory for sending.
Dialled Number	Fax number dialled.
Received Id	Number (and name if available) of the person called providing it has been stored on their fax machine.
Date/Time	Date and time fax was sent or received.
Duration	Length of call in minutes and seconds.
Pages	Total number of pages sent or received.
Result	OK if fax was sent or received successfully. XX ERROR CODE if the fax did not go through properly. <i>See page 41</i> for the meaning of the error codes.

To switch automatic printing of transmission and error reports on and off

Function



Press until the display shows FAX SET-UP



Display shows DATE AND TIME

Function



Display shows VARIOUS SETTINGS



Press until the display shows FAILED TX REPORT



Press to display the option you want

FAILED TX REPORT – print a report only after a fax has failed to be sent.

TX REPORT ALWAYS – print a report after every sent fax.

TX REPORT OFF – no reports will be printed.



Press to confirm.



Press to return your machine to standby.

To switch automatic printing of broadcast reports on and off

Function



Press until the display shows FAX SET-UP



Display shows DATE AND TIME.

Function



Display shows VARIOUS SETTINGS.



Press until the display shows BROADCAST REP: ON



Press to switch between the ON and OFF settings.



Press to confirm the option displayed.



Press to return your machine to standby.

To switch automatic printing of delayed transmission on and off.

Function



Press until the display shows FAX SET-UP



Display shows DATE AND TIME

Function



Display shows VARIOUS SETTINGS



Press until the display shows DELAY LIST: OFF



Press to switch between the ON and OFF settings.



Press to confirm the option displayed.



Press to return your machine to standby

To request immediate print-outs

You can get print-outs of transmission, activity and broadcasting reports.

Function



Press until the display shows PRINT OUT REPORT



Display shows LAST TX REPORT



Press to select the report you want to print:

LAST TX REPORT

LAST BROADCAST REP

ACTIVITY REPORT

PRINT OUT: EXIT – to cancel without printing.



Press to confirm the option displayed.

Your PaperJet 55 prints the following lists

You can obtain at any time a print-out of:

- setup and configuration of your machine
- speed dialling entries
- one-touch entries.

To print the set-up list

Function



Press until the display shows INSTALLATION



Display shows TEL. LINE SET-UP

Function



Press until the display shows PRINT INSTALL.



Display shows PRINT OUT:



Press to start the print out.



Or



To return to standby without printing.



Or



Press < > to display PRINT OUT: EXIT.



Press to return to the INSTALLATION menu.

To print the configuration, speed dial and one-touch lists

Function



Press until the display shows FAX SET-UP



Display shows DATE AND TIME

Function



Press until the display shows PRINT OUT SET UP



Display shows PRINT SETTINGS



Press to display the option you want ONE TOUCH, SPEED DIAL or SETTINGS.



Press to start the printout.



Or



To return to standby without printing.



Or



Press < > to display PRINT OUT: EXIT.



Press to return to the FAX SET UP menu.

Making and receiving phone calls

You can use your PaperJet 55 as a normal telephone.

To make a phone call.

Lift the receiver.



Dial the phone number.

To dial a one-touch phone number

Do not put a document in the document feeder.

You can dial without lifting up the handset.

0-9

Press and hold the memory location number you want until the telephone number (if stored) is displayed. The number is automatically dialed.

When you hear your call being answered, lift the handset and talk.

NOTE

You can dial by all methods by lifting the handset first if you wish.

For one touch and speed dial numbers use the speed dial button.

To make a speed dial call

Do not put a document in the document feeder.

You can dial without lifting the handset.

Speed Dial



Clear

01-32

Press the **Speed dial** button.

Enter speed dial code you want. The telephone number (if stored) is displayed and dialed.

When you hear your call being answered, lift the handset and talk.

To search through the speed dial entries

Do not put a document in the document feeder.

You can dial without lifting the handset

Speed Dial



Clear

Press the **Speed dial** button. Display shows
TEL CALL
CODE OR < >



Press to scroll through the entries until the one you want is displayed.



Start

The number is dialed.

When you hear your call being answered, lift the handset and talk.

To put a caller on hold

You can put a caller on hold while you talk to someone else close by.

RX Mode



Press to put your caller on hold.

Your caller will hear a beep, and will not be able to hear you.

RX Mode



Press again to resume your conversation.

Copying documents

Your PaperJet 55 can act as a convenience copier and make multiple copies of a document as well as enlarging or reducing your original.

Do not use

- Torn, crumpled and rolled paper
- Paper that is too thin
- Wet or moist paper
- Carbon paper
- Correction fluid, paper clips or staples.

To copy a document

Insert the document to be copied into the document feeder.



Press the **Copy** button. Display shows the current contrast, resolution and size settings.

100% TEXT
NORMAL



Select the contrast **LIGHT, DARK, NORMAL.**



Select the resolution **TEXT, PHOTO**



Select the size **100%, 140% 70%.**



1-9

Enter the number of copies required.



Your machine scans the document one page at a time, printing the copies after each page.

To stop copying



Press the **Stop** button. Display shows copy interrupted.

Remove any remaining sheets of paper in the document feeder.



Press the **Stop** button again to confirm.

Additional features

To set the print quality

You can adjust the output quality of the printer. There are 2 settings: NORMAL and HIGH QUALITY. The default setting is HIGH QUALITY.

Function



Press until the display shows FAX SET-UP



Display shows DATE AND TIME

Function



Press until the display shows PRINTER PARAMET.



Press until the display shows COPY: HIGH QUAL



Press to switch between NORMAL and HIGH QUAL



Press to confirm the option displayed.



To return your machine to standby.

To set the print area of a document

You can set the print area of a received fax to 70% 76%, 80% or 94% of the original. The recommended reduction settings are: A4 = 94%, Letter = 80%, Legal = Off (no reduction).

The default setting is 94%.

Function



Press until the display shows FAX SET-UP



Display shows DATE AND TIME

Function



Press until the display shows PRINTER PARAMET.



Press until the display shows REDUCTION 94%



Press to switch between 94%, 80%, 76%, 70% and OFF.



Press to confirm the option displayed.



To return to standby.

To receive a document longer than the paper size

If you receive a document sent using a longer paper size than the one in your fax machine, you may find the text is cut off.

You can make the fax print the remaining text on another sheet.

Function



Press until the display shows FAX SET-UP



Display shows DATE AND TIME

Start



Display shows PRINTER PARAMET.



Press until the display shows SURPLUS: AUTO

Start



Press to select ON from the options of AUTO, ON and OFF

If you select AUTO, your machine will print remaining text on another sheet providing it fills at least 12 mm of the page. By selecting ON you ensure that any surplus text is printed on another page. If you select OFF, your machine will not print any surplus text.



Press to confirm.



To return to standby.

To set the number of rings before your fax machine takes a call

If the fax machine is set to AUTOMATIC RX or PHONE FAX RX, it is pre-set to answer incoming calls after 2 rings.

You can change the number of times it rings before taking the call

Function



Press until the display shows INSTALLATION



Display shows TEL.LINE SET-UP



Press until the display shows RING COUNT:02



Press to set the number of rings to 01, 02, 04 or 08.



Press to confirm the option displayed.



To return to standby.

To adjust the ringer volume

You can switch between High, Medium, Low and Off. The default setting is High.

Function



Press until the display shows FAX SET-UP



Display shows DATE AND TIME

Start



Display shows VARIOUS SETTINGS



Press until the display shows RING VOLUME: HIGH



Press to switch between the settings HIGH, MEDIUM, LOW and OFF.



Press to confirm the option displayed.



To return to standby.

To adjust the duration of the phone call alert beeps

When your PaperJet 55 is set to PHONE/FAX RX mode it automatically answers all calls. If it is a phone call, it is set to beep for 20 seconds to alert you to pick up the handset. You can adjust the duration of these beeps.

Function



Press until the display shows INSTALLATION



Display shows TEL.LINE SET-UP



Press until the display shows FAX/TEL
TIMER:20



Press to switch between the options of 15,
20, 30 and 40 seconds.



Press to confirm the option displayed.



To return to standby.

Receiving a fax call via an extension phone (Remote Start)

If you answer a call on an extension phone connected to the same line as your PaperJet 55 and you hear fax tones, you can switch your PaperJet 55 into fax receive mode by dialling ✱ 5. This is like pressing the **Start** button.

When you hear your PaperJet 55 respond with its own fax tones, hang up the extension phone.

You can replace the **5** of this code with any digit from **0-9**.

To change the remote start code

Function



Press until the display shows INSTALLATION



Press **Start** until the display shows TYPE
CODE ✱5



Enter the new digit you want after the ✱.
Note that the ✱ cannot be changed.



Press to confirm.



To return to standby.

To switch remote start off/on

Function



Press until the display shows INSTALLATION



Press until the display shows REMOTE
START: ON



Press to change from ON to OFF.



Press to confirm the setting. The display
shows RING COUNT XX.



Press to return to standby.

To switch the fax tones on and off

Your machine will automatically play dialling tones and fax connection tones over the loudspeaker so that you can hear the progress of the call. You can switch the tones on and off.



Press until the display shows
INSTALLATION



Display shows TEL.LINE SET-UP



Until the display shows DIAGNOSTICS



Press until the display shows LINE
MONITOR: ON



Press to switch between ON and OFF. If you
select OFF, you will not hear the dialling and
fax connection tones.



Press to confirm the option displayed.



To return to standby.

To adjust the loudspeaker volume

While the machine is in standby



Display shows TYPE NUMBER.



Press to raise or lower the volume.

To adjust the volume of the buzzer

Function



Press until the display shows FAX SET-UP



Display shows DATE AND TIME

Start



Display shows VARIOUS SETTINGS



Press until the display shows BUZZER VOL.LOW

Start



Press to switch between HIGH, MEDIUM, LOW
and OFF.



Press to confirm the option displayed.



To return to standby.

To adjust the speed a fax is sent at

Your PaperJet 55 is set to send faxes at
14400bps. If you consistently fail to send
faxes to a particular number it might help
to reduce the transmission speed to
4800bps.

Function



Press until the display shows FAX SET-UP



Display shows DATE AND TIME

Start



Display shows VARIOUS SETTINGS



Press until the display shows TXSPEED 14.4

Start



Press to switch between 14.4, 9.6 and 4.8.



Press to confirm the option displayed.



To return to standby.

To switch ECM mode on/off

ECM (Error Correction Mode) is a system for correcting errors caused by interference on the line. When switched on, the display shows E when sending or receiving to/from another machine using ECM. The default setting for your machine is to have ECM switched ON and you should not have to change it. However, you can switch it off if you wish.

Function



Press until the display shows FAX SET-UP



Display shows DATE AND TIME

Function



Display shows VARIOUS SETTINGS



Press until the display shows ECM: ON

Start



Press to switch between ON and OFF.



Press to confirm the option displayed.

Start



To return to standby.

Stop

Polling

Polling lets you call another fax machine to retrieve a document automatically.

It also enables another fax machine to call your PaperJet 55 and request a document that you have set ready to be received.

This is often also known as 'faxback'.

To poll a document from another fax machine

When you know that another fax machine has a document ready for polling, you can set your PaperJet 55 to receive the document.

Function



Press until the display shows POLLING RX



Press until the display shows TYPE TIME

Start

Either



Enter the time you want to start calling the other fax machine then press **Start**.

Or



Press the **Start** button to begin polling immediately. Display shows TYPE FAX NUMBER

Start



Dial the number of the fax machine from which you want to poll a document.



Press to confirm. Display shows POLL RX and the time at which you have set it to poll. You can still send and receive other faxes as normal.

Start

To cancel polling

Function



When you have set a polling time

Press until the display shows POLLING RX



Start

Display shows ALREADY ENTERED



Start

Display shows CHANGE PARAM?



Volume

To display CANCEL SETTING?



Start

To confirm cancellation. Your fax machine returns to standby.

To set a document for polling by another fax machine

Insert a document in the document feeder.
Display shows DOCUMENT READY

Set the resolution and contrast if necessary.

Function



Press until the display shows POLLING TX



Start

Press twice. Display shows AUTOMATIC RX
POLLING TX SET

To cancel polling remove the document from the feeder. To cancel during polling press **Stop**.

To change a polling time and number

Function



When you have set a polling time

Press until the display shows POLLING RX



Start

Display shows ALREADY ENTERED



Start

Display shows CHANGE PARAM?



Start

Display shows TYPE TIME
HH:MM



If required, use the keypad to enter the new time. This overwrites the original one.



Start

Display shows TYPE NUMBER



If required, enter the new number. This overwrites the original one.



Start

Display shows AUTOMATIC RX
POLL RX

Connecting an answering machine

Your PaperJet 55 can work with an answering machine so that you can take voice and fax messages.

To ensure the two machines work together, the fax machine must be in TAD/FAX RX mode and the answering machine line cord must be connected into the socket on the back of the PaperJet 55's line cord doubler plug.

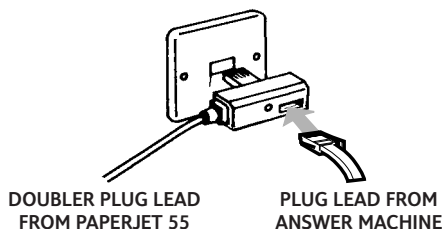

When set up like this, and a call comes in, your answer machine will always answer the call first. Your PaperJet 55 will monitor the call and take control if it detects that it is a fax call.

If the answering machine fails to answer, PaperJet 55 will answer the call after 10 rings and prepare to receive a fax.

To set the receive mode



Press to display TAD/FAX RX.

To set up your answering machine

If you can choose the number of rings before your answering machine takes the call (refer to your answering machine's guide for instructions), it is recommended that you set the number of rings on your answer machine to between 2 and 4.

For optimum performance, the outgoing message on the answer machine should be as short as possible and should not exceed the times shown below:-

No. of rings before answer	Length of outgoing message
2	14 seconds
4	8 seconds

If your fax machine fails to take fax calls off the answering machine

If your PaperJet 55 fails to take fax calls from the answer machine then first you should check that the outgoing message on the answer machine is not too long. If the outgoing message is OK, the problem may be because the calling machine is not sending fax tones (some older machines do this). Your PaperJet 55 should cope with this by switching to fax if it detects long periods of silence – it is preset to switch to fax if it detects 6 seconds of silence. You may need to shorten this detection time to suit your particular answer machine.

If your fax machine interrupts when messages are being left

If your PaperJet 55 sometimes switches to fax while callers are trying to leave a message, it may help to increase the silence detection time or to switch it off.

To change the silence detection time

Function



Press until the display shows **INSTALLATION**.



Display shows **TEL.LINE SET UP**.



Press until the display shows **SILENCE LAPSE: 6**.



Press to set the lapse time to **3, 4, 6, 8, 10 seconds** or **NO (off)**.



Press to confirm the option displayed.



Press to return to standby.

Connecting to a switchboard

You can store the access code required to get an outside line so that you only have to press the **EXTERNAL** button.

With some switchboards you may also need to switch your PaperJet 55 from TONE dialling to PULSE dialling. Check with your switchboard manager or supplier to see if this is necessary.

To set the dialling mode and access number

While your PaperJet 55 is in standby mode



Press the **Function** button until the display shows **INSTALLATION**



Display shows **TEL.LINE SET-UP**



Display shows **PUBL. LINE (PSTN)**



Press until the display shows **PRIV. LINE (PBX)**



Display shows **PBX DIAL: TONE**



Press to switch between **TONE** and **PULSE**.



Press to confirm. Display shows **EXT. LINE: PREFIX**



Press the **< >** buttons to display the options: **FLASH** or **PREFIX**. If your access code is recall choose **FLASH**. If your access code is a digit(s) choose **PREFIX**.



Press **Start** to confirm your choice.

If you select **PREFIX** you are asked for the code needed to get an outside line via your switchboard (max. three digits).



Enter your code.



To confirm.

Display shows **PSTN DIAL: TONE**



Press to switch between **TONE** and **PULSE** settings to suit your switchboard.



To confirm.



To return to standby.

Using the External button

External
○

You can use the **External** button to insert the access code before numbers stored in the one touch and speed dial memories.

External
○

Before entering the number (*pages 21-22*), press **External**, an E will appear in the display, and continue entering the number as normal.

External
○

When dialling manually, just press **External** before dialling the number.

To switch dialling mode during a call

★

If you are using your PaperJet 55 in PULSE dialling mode, you can change to TONE mode during a call using the ★ button. This might be useful when calling interactive services such as the BT Customer Services line on 150.

After pressing the ★ button all subsequent digits will be dialled in TONE mode. When you end the call, dialling will revert to PULSE mode.

Help

The error light comes on and an error message is displayed.

An error report is automatically printed. Press the **Stop** button to reset the machine and check the message against the Error Messages list, *page 42*.

If you run out of paper or ink.

Your PaperJet 55 will store incoming faxes in the memory.

If you run out of paper or ink or the paper jams during reception, or if you open the printer cover, printing will stop and the fax you are receiving will be stored in the memory. Once the problem has been resolved, your machine will start printing again.

If there is a power failure

In the case of power failure, the fax machine will keep the data for:

- date and time
- machine settings
- numbers stored in the one-touch and speed dial memories
- reports

Any documents stored in the memory will be lost.

When the power is restored your machine will print out a report which shows the total number of pages (both received and stored for sending) lost from the memory.

Your machine doesn't switch on

Check that the mains power is plugged in and switched on.

The document cannot be inserted into the document feeder

Check the size of the document. See *page 15* for correct sizes.

Fax documents are not sent

Check that the document is not jammed in the machine.

The line may be busy. Your machine will retry automatically 3 times at 2 minute intervals.

Your machine does not receive faxes automatically

- Check that it has not been set for manual reception.
- Check that you have ink and paper.
- Check for paperjams.

You cannot print faxes or copy documents

- Check for paper jams.
- Check that you have ink and paper.
- The type of paper you are using may not be correct, check paper size and weight shown on *page 15*.

Your machine prints out completely blank copies

You may have inserted the document to be copied the wrong way around. Place the side to be copied face down.

Error codes

Other problems may be accompanied by a display of **ERROR CODE** and a number. Check the number against the list below.

CODE	MESSAGE	ERROR CAUSE	ACTION
OK	No message. Operation completed successfully		No action.
03	RECEIVER DOES NOT ANSWER	The number you are calling does not answer or is not a fax or there is no dial tone.	Check for dial tone by lifting the handset and if OK try calling again.
04	ERR.WHILE TRANSMITTING RESEND FROM PAGE: nn	A problem has occurred while sending a fax. "nn" = page number on the which the error occurred.	Send again starting from the page shown in the report.
05	RESEND PAGES: nn, nn	The machine you are calling detected errors during the send. "nn" = page number on which the error occurred.	Send again starting from the page shown in the report.
07	DOCUMENT TOO LONG or SENDING STOPPED	Transmission time for a page exceeds the permitted limit.	Try sending again.
08	CHECK THE DOCUMENT	Optical scanner unable to read the document or document may be too long.	Remove and re-insert document in the feeder and try again. Check paper is not longer than 360mm (US Legal Length).
09	STOP PRESSED	You have stopped the machine.	No action.
10	No message	Fax has detected an error while receiving a fax.	Ask sender to send fax again.
11	No message	Printer problem while receiving a fax. Document stored in the memory but the memory capacity has been exceeded.	Correct the printing problem, then wait for the stored document to be printed. Ask sender to fax the rest of the document.
13	ERRORS WHILE POLLING	Polled fax machine has no document ready or was not set for polling.	Contact the sender.
16	POWER FAILURE ON PAGE	Power failure while sending or receiving a document.	Send again from the page shown on the report.
(OK)	No message.	Document has been received but printing quality is poor.	Contact sender.
OCC	LINE BUSY	The line is engaged.	Try again later.

Error messages

If you see an error message on the display, check here for its meaning and solution. Messages are listed in alphabetical order.

AUTOREDIAL nnn

Last fax call failed. Your machine will redial after nnn seconds.

CHECK DOCUMENT; PRESS

The document is not going through properly. Remove and re-insert the document in the document feeder. Press the **Stop** button to return to standby and send again.

CHECK PAPER; PRESS

You have run out of paper. Add paper and press the **Stop** button to return to standby.

Or

The paper is not going through properly. Remove and re-insert the paper. Press the **Stop** button to return to standby.

CHECK PRINT HEAD

The print head has not been installed or has been installed incorrectly. Install the print head again.

Some print nozzles may be damaged, reducing print quality. Clean the print head (*see page 46*).

COPY INTERRUPTED

The **Stop** button has been pressed.

Or

There was a problem during copying and it could not be printed. Check the type of problem on the display and clear it.

COVER OPEN

Close the printer compartment cover.

DOC IN MEMORY

A received fax is stored in the memory because it could not be printed right away. Check the problem on the display and clear it.

LAST TX ERR. XX

The last fax sent was not completed successfully. Press the **Last TX** button to send again or press the **Stop** button to return your machine to standby.

MEMORY FULL

Because of a printing problem (no paper, paper jam, no ink, cover open etc) documents have been received into the memory. Resolve the printing problem and the documents will automatically be printed and the memory cleared.

NOT PROGRAMMED

You have chosen a one-touch button or speed dial code which does not have an entry stored.

OUT OF INK

The ink in the cartridge has run out. Change the cartridge (*see Changing the print head/cartridge, page 44*).

PAPER ERROR; PRESS

Paper jam. Press the **Stop** button and, if the paper sheet is not ejected automatically, check where it is jammed and remove it. (*See Removing jammed pages, page 48.*)

POLL. RETRY nnn

The last polling call failed. Your fax is waiting to redial the number after nnn seconds.

REMOVE DOCUMENT, PRESS 

A document jam has occurred. Press the **Stop** button and if the page is not ejected automatically, remove it by hand. (See *Removing jammed pages*, page 48.)

Or

Document scanning has been interrupted by pressing the **Stop** button.

RX ERROR

An error has occurred during fax reception. Press the **Stop** button to turn off the Error light and clear the message. You may need to ask the sender to re-send the fax.

RX IN MEMORY

A problem has occurred during reception and the fax has continued to be received in the memory. The bottom line of the display tells you what the problem is. Resolve the problem and the fax will automatically be printed.

SYSTEM ERROR nn

Your machine has locked up. Note the error code. PaperJet Helpline is **0845 052 0052**.

TX ERROR

Your last fax was not sent correctly. Press the **Stop** button to turn off the Error light and clear the message. Check the number you are sending to and try sending your fax again.

Beeps

Error beeps

Short beep – wrong key pressed when following a set of instructions.

Long beep – unsuccessful procedure.

Continuous beep – handset is off-hook.

Advice beeps

Short beep – confirms fax sent or received successfully.

Beeps for 20 seconds – phone call, lift receiver to answer.

Memory capacity

Your PaperJet 55 can store up to 21 pages of this standard letter (reproduced A4 size).

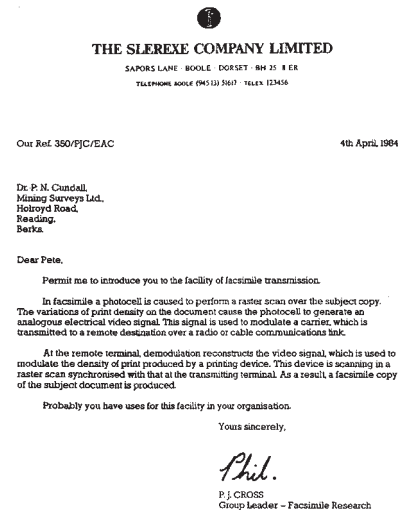

BT PaperJet Helpline

If you cannot resolve a problem by using the Help section, contact the Helpline on **0845 052 0052**.

Maintenance

Cleaning your PaperJet 55

First disconnect it from the mains power supply and the telephone line.

Clean with a cloth dampened with diluted washing-up liquid. Never use household polish as this may damage your fax machine. Never use a dry cloth as this may cause static shock.

Changing the printhead/cartridge

Your PaperJet 55 is supplied with a starter print cartridge and it is not possible to change the ink cartridge independently of the print head.

Replacements have ink cartridges which can be replaced independently of the printhead. You can use the same printhead with up to 6 cartridges. You should then change both the cartridge and printhead.

Changing the printhead/cartridge assembly

- 1 Open the printer compartment cover.

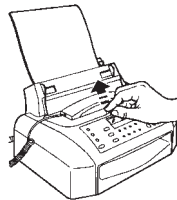

NOTE

For details on changing between black and colour cartridges, see the separate PaperJet 55/65 PC Printing Guide.

- 2 Pull the green levers towards the front of the machine to release the printhead assembly.

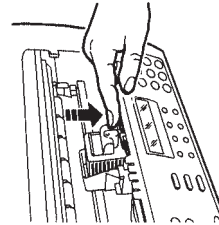

- 3 Lift out the assembly.

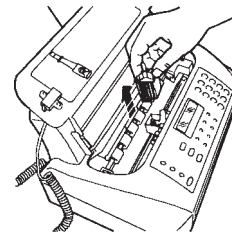

- 4 Remove the new printhead assembly from its packaging. Holding it by the finger grip, peel the protective film from the print nozzles.

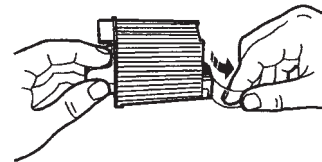

- 5 Avoid touching the nozzles and metal electrical contacts.

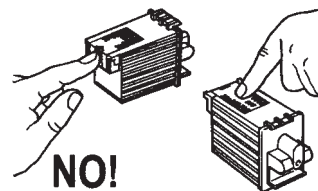

- 6 Insert the new assembly into the holder with the electrical contacts facing towards the front of the machine.

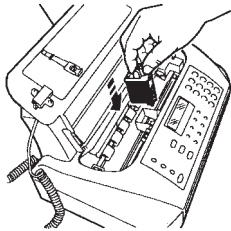

- 7 Pull the assembly towards the front of the machine until you hear it click into position.

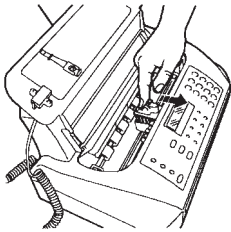

- 8 Close the cover.

Changing the ink cartridge

- 1 Open the printer compartment cover.

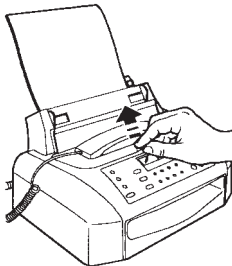

NOTE

It is recommended that the printhead is changed after every six cartridges.

- 2 Gently pull the black lever at the side of the printhead assembly to the side to release the cartridge.

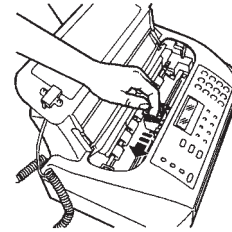

- 3 Lift out the cartridge.

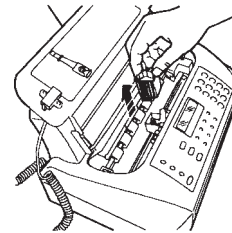

- 4 Remove the new cartridge from its packaging. Holding it by the finger grip, peel off the protective film.



- 5 Insert the new cartridge into the printhead until it clicks into place.

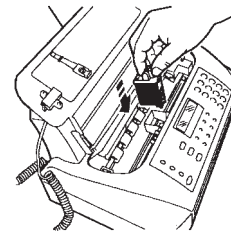

It should be orientated as shown on next page.



6 Close the cover

To clean the print head and nozzles

If the printing quality deteriorates you can quickly clear the print head and test the nozzles with a print-out showing their condition.



Press the Function button until the display shows **HEAD MAINTENANCE**



Display shows **NEW HEAD: ON**

Either



If the print head is new, press the **Start** button. Your PaperJet 55 performs a print test.

Or



If the print head is not new, press to display **NEW HEAD: OFF**



Display shows **CLEANING: ON**



Your machine performs a print test.



To cancel, press the **Stop** button.

To interpret the print test, *see page 12*.

If the printout shows **NOZZLE DAMAGED** then you should clean the printhead contacts, *see opposite*.

Manually cleaning the printhead contacts

Lift the printer compartment cover.

Remove the print cartridge and head.

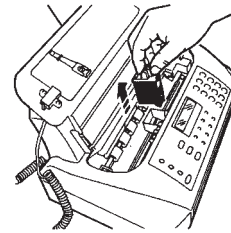

Use a slightly damp cloth to clean the electrical contacts taking care not to touch the nozzles.

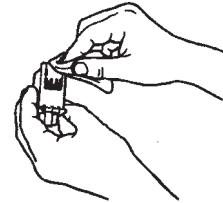

Use a slightly damp cloth to clean the electrical contacts of the carriage inside the machine.

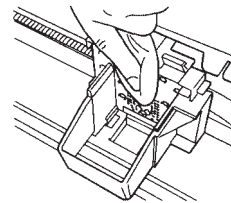

Replace the print head and cartridge.

Close the cover.

Cleaning the print head pad

Lift the printer compartment cover.

Move the print cartridge to the right hand side of the machine.

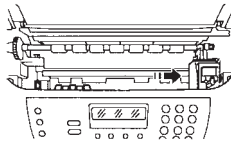

Clean excess ink off the print head pad with a dry cotton swab.

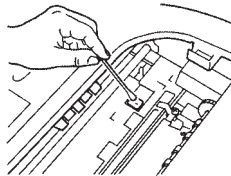

Close the cover.

Cleaning the optical scanner

Dust or dirt on the optical glass may cause scanning problems such as vertical lines on a received fax or copied document.

If after cleaning, you still get vertical streaks on printed documents, contact your service engineer.

NOTE

Switch your machine off at the mains.

Lift the printer compartment cover.

Move the print head to the left hand side of the machine.

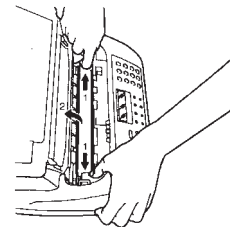

Lift the hinged metal plate using the lever located on the right hand side of the machine.

Clean the optical scanner with a cloth dampened with a product specially designed for cleaning glass. Then carefully wipe it dry. Do not pour or spray cleaning fluid directly onto the glass.

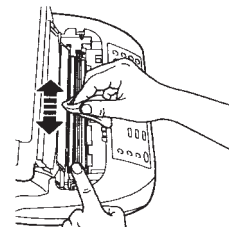

Lower the hinged plate and close the printer compartment cover.

Removing jammed pages

If a document or sheet of paper becomes jammed while sending a fax or during copying the display shows REMOVE DOCUMENT, PRESS 

If paper used to print received faxes or photocopies becomes jammed the display shows PAPER ERROR, PRESS 

First try ejecting the paper by pressing the **Stop** button.

If the paper does not come out automatically:

Remove any paper still in the feeders.

Lift the printer compartment cover.

Press down the green lever on the left hand side of the machine and remove the jammed paper.

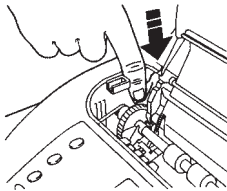

Technical information

PaperJet 55

Model	Desktop transceiver
Display	LCD 16 + 16 characters.
Memory capacity*	21 pages

Dimensions

Width	359mm
Depth	234 + 84mm (with paper support extension)
Height	180mm + 138mm (with paper support extension)
Weight.....	4.5kg

Communication features

Telephone network.....	Public/private
Compatibility	ITU
Communication speed	14400-12000-9600-7200-4800-2400bps
Compression method	MH, MR

Power features

Power supply.....	220-240 VAC, 50-60Hz
Power consumption.....	7W standby, 35v max

Optical scanner features

Scanning method.....	CIS
Reading resolution	
horizontal	8 pixel/mm
vertical STANDARD	3.85 lines/mm
vertical FINE	7.7 lines/mm

PC features

Parallel connection	36 line centronics
---------------------------	--------------------

Transmission features

Transmission time	10s (14.4kbps)
Automatic document feeder	5 sheets A4, Letter and Legal

Reception features

Printing method	Printing on plain paper with ink jet printer
Max. printing width	208mm
Printing paper	A4 (210 x 297mm), Letter and Legal US Letter (216 x 279mm) and US Legal (216 x 356mm) Weight 70-90gsm
Paper feed	Plain paper cassette 40 sheets, 80gsm)
Environmental conditions	from 5°C to +35°C (operating) from -15°C to +45°C (transport) from 0°C to +45°C (storage and parking)
Relative humidity	15%-85% (operating, storage, parking) 5%-95% (transport)

*ITU TS format, Test Sheet No.1 (Slerexe Letter) in standard resolution with MH compression.

R&TTE

This product is intended to be connected to analogue networks and private switching systems in the United Kingdom.

This product complies with the essential requirements of the Radio and Telecommunications Terminal Equipment Directive 1999/5/EC.

Index

A ctivity report	24	Extension telephone	
Alert beeps	31	change remote start code	31
Answering machine – connecting	35	receiving a fax call	31
B roadcast a document	19	ECM mode on/off	33
C alls		F ax	
dial one-touch number	27	contrast and resolution	15
make	26	delayed faxing	18
on hold	27	dial and hear progress	16
number of rings	30	dial using handset	17
speed dial	27	enter name and number	13
Change		from memory	19
cartridge	44	header	14
printhead	44	receiving	20
Cleaning	44, 46	redial	17
Contrast	15	send	15-16
Copying documents		stored	19
copy a document	28	tones on/off	32
stop copying	28	H andset	
D ate	13	connect	9
Delayed faxing	18	Help	39
Document retransmission on/off	17	I nk cartridge	44
E nter		L ists	
fax number	13	configuration	26
name	13	one-touch	26
Error codes	41	set-up	26
Error messages	42	speed dial	26
		Load paper	10

M ake a call	26	R eceiving	
Memory		document longer than paper size	30
capacity	43	faxes	20
fax from	19	Redial	
N umber of rings	30	automatic re-dialling	17
O ne-touch memories		last number	17
delete	22	Remote start	31
edit	22	Reports	
send	22	activity	24
store	21	automatic printing	25
P aper		delayed transmission	24
check size	11	broadcasting	24
jammed	48	transmission	24
load	10	power failure	24
type/size	15	request print-outs	25
PC cable socket	4	Resolution	15
PC connecting	4	Ringer volume	30
Polling		S afety	8
cancel	34	Setting up	9
change time and number	34	Send	
from another fax	33	fax	15
set by another fax machine	34	fax at pre-set time	18
Power	10	Set	
Power failure	39	contrast and resolution	15
Pre-set fax		date	13
change details	18	time	13
send	18	Speed dial call	27
Print area	29	Speed dial memories	
Print head	44	delete	23
Print quality		edit	23
set	29	send	23
test	12	store	22

Speed fax sent	32
Starter print cartridge	11
Switchboard	
set access number	37
set dial mode	37
switch dialling mode	38
T echnical information	49
Telephone line cord	9
Time	13
Tones on/off	32
V olume	
buzzer	32
loudspeaker	32
ringer	30



Offices worldwide

The telecommunications services described in this publication are subject to availability and may be modified from time to time. Services and equipment are provided subject to British Telecommunications plc's respective standard conditions of contract. Nothing in this publication forms any part of any contract.

Touchtone[™] is a registered trade mark of British Telecommunications plc in the UK.

© British Telecommunications plc 2000.
Registered Office: 81 Newgate Street, London EC1A 7AJ.
Registered in England No. 1800000.
PaperJet 55 user guide (10/01) 3
Designed by The Art & Design Partnership Limited.
Printed in Thailand.

Printed on paper which meets international environmental standards.

