

TOSHIBA
Leading Innovation >>>

SERVICE MANUAL

FACSIMILE

GD-1220/1221



© 2006 - 2008 TOSHIBA TEC CORPORATION All rights reserved

Under the copyright laws, this manual cannot be reproduced in any form without prior written permission of TOSHIBA TEC CORPORATION. No patent liability is assumed, however, with respect to the use of the information contained herein.

GENERAL PRECAUTIONS REGARDING THE SERVICE FOR e-STUDIO165/167/205/207/237 AND GD-1220/1221

The installation and service should be done by a qualified service technician.

1) Transportation/Installation

- When transporting/installing the equipment, remove the drawer, employ two persons and be sure to hold the positions as shown in the figure.
The equipment is quite heavy and weighs approximately 32.5 kg (71.65 lb), therefore pay full attention when handling it.

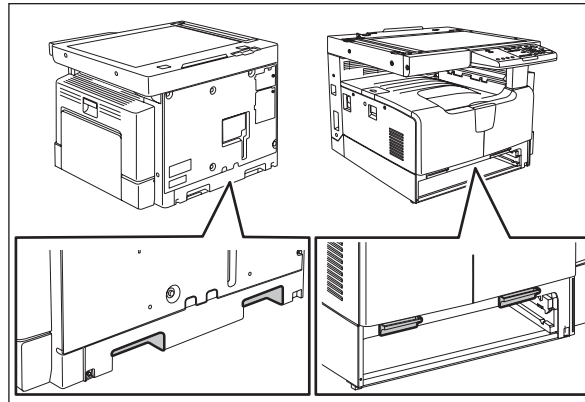

- Be sure not to hold the movable parts or units when transporting the equipment.
- Be sure to use a dedicated outlet with AC 110 V / 13.2 A, 115 V or 127 V / 12 A, 220-240 V or 240 V / 8 A for its power source.
- The equipment must be grounded for safety.
- Select a suitable place for installation. Avoid excessive heat, high humidity, dust, vibration and direct sunlight.
- Provide proper ventilation since the equipment emits a slight amount of ozone.
- To insure adequate working space for the copying operation, keep a minimum clearance of 80 cm (32") on the left, 80 cm (32") on the right and 10 cm (4") on the rear.
- The equipment shall be installed near the socket outlet and shall be easily accessible.
- Be sure to fix and plug in the power cable securely after the installation so that no one trips over it.

2) General Precautions at Service

- Be sure to turn the power OFF and unplug the power cable during service (except for the service should be done with the power turned ON).
- Unplug the power cable and clean the area around the prongs of the plug and socket outlet once a year or more. A fire may occur when dust lies on this area.
- When the parts are disassembled, reassembly is the reverse of disassembly unless otherwise noted in this manual or other related documents. Be careful not to install small parts such as screws, washers, pins, E-rings, star washers in the wrong places.
- Basically, the equipment should not be operated with any parts removed or disassembled.
- The PC board must be stored in an anti-electrostatic bag and handled carefully using a wristband since the ICs on it may be damaged due to static electricity.

Caution: Before using the wristband, unplug the power cable of the equipment and make sure that there are no charged objects which are not insulated in the vicinity.

- Avoid expose to laser beam during service. This equipment uses a laser diode. Be sure not to expose your eyes to the laser beam. Do not insert reflecting parts or tools such as a screwdriver on the laser beam path. Remove all reflecting metals such as watches, rings, etc. before starting service.
- Be sure not to touch high-temperature sections such as the exposure lamp, fuser unit, damp heater and areas around them.
- Be sure not to touch high-voltage sections such as the chargers, developer, high-voltage transformer and power supply unit. Especially, the board of these components should not be touched since the electric charge may remain in the capacitors, etc. on them even after the power is turned OFF.
- Make sure that the equipment will not operate before touching potentially dangerous places (e.g. rotating/operating sections such as gears, belts pulleys, fans and laser beam exit of the laser optical unit).
- Be careful when removing the covers since there might be the parts with very sharp edges underneath.
- When servicing the equipment with the power turned ON, be sure not to touch live sections and rotating/operating sections. Avoid exposing your eyes to laser beam.
- Use designated jigs and tools.
- Use recommended measuring instruments or equivalents.
- Return the equipment to the original state and check the operation when the service is finished.

3) Important Service Parts for Safety

- The breaker, door switch, fuse, thermostat, thermofuse, thermistor, batteries, IC-RAMs including lithium batteries, etc. are particularly important for safety. Be sure to handle/install them properly. If these parts are short-circuited and their functions become ineffective, they may result in fatal accidents such as burnout. Do not allow a short-circuit or do not use the parts not recommended by Toshiba TEC Corporation.

4) Cautionary Labels

- During servicing, be sure to check the rating plate and cautionary labels such as “Unplug the power cable during service”, “CAUTION. HOT”, “CAUTION. HIGH VOLTAGE”, “CAUTION. LASER BEAM”, etc. to see if there is any dirt on their surface and if they are properly stuck to the equipment.

5) Disposal of the Equipment, Supplies, Packing Materials, Used Batteries and IC-RAMs

- Regarding the recovery and disposal of the equipment, supplies, packing materials, used batteries and IC-RAMs including lithium batteries, follow the relevant local regulations or rules.

Caution:

Dispose of used batteries and IC-RAMs including lithium batteries according to this manual.

Attention:

Se débarrasser de batteries et IC-RAMs usés y compris les batteries en lithium selon ce manuel.

Vorsicht:

Entsorgung der gebrauchten Batterien und IC-RAMs (inclusive der Lithium-Batterie) nach diesem Handbuch.

CONTENTS

1. SPECIFICATIONS AND OUTLINE OF SYSTEM	1-1
1.1 FAX Options	1-1
1.2 Specifications.....	1-2
1.3 Features	1-5
1.4 Accessories and Parts	1-8
1.5 Options	1-9
1.6 System List.....	1-10
1.7 Units and Components	1-11
1.8 Layout of PC Boards.....	1-12
2. LSU-RELATED FUNCTIONS	2-1
2.1 Recording paper size.....	2-1
2.2 Effective recording area.....	2-2
2.3 Print mode	2-4
2.4 Recording paper selection algorithm and print algorithm	2-5
2.4.1 Recording paper selection algorithm	2-5
2.4.2 Print algorithm	2-5
2.5 Error processing	2-14
2.6 Limitations on reception print.....	2-15
3. DIALING/COMMUNICATION CONTROL.....	3-1
3.1 Circuit Connection and Procedure to Change Mode	3-1
3.1.1 Dial call-up transmission to a telephone circuit	3-1
3.1.2 Selection of the communication mode	3-2
3.1.3 Procedure to select the transmission mode	3-2
3.2 Signaling System Diagram and Signal Forms	3-3
3.2.1 Circuit control signals	3-3
3.2.2 Communication with the binary signals	3-4
3.2.3 V.8/V.34 communication sequence	3-12
3.3 FAX Automatic Switching	3-25
3.3.1 General functions	3-25
3.3.2 TEL mode.....	3-25
3.3.3 FAX mode	3-25
4. ELECTRICAL CIRCUITS	4-1
4.1 Configuration	4-1
4.2 Description of Circuits.....	4-2
4.2.1 Configuration	4-2
4.2.2 Line path switching control circuit.....	4-4
4.2.3 Dial pulse generation circuit	4-6
4.2.4 Line current detection circuit	4-8
4.2.5 CI detection circuit.....	4-10
4.2.6 Line monitor circuit	4-12
4.3 PC Boards	4-15
5. INSTALLATION	5-1
5.1 Explanation to the Users.....	5-1

1. SPECIFICATIONS AND OUTLINE OF SYSTEM

1.1 FAX Options

e-STUDIO165/167/205/207/237 can be used as a FAX by installing the FAX unit (GD-1220/1221). Some options can be added when the FAX unit is installed or to extend the FAX functions (📖 P. 1-9 "1.5 Options"). The external keyboard (GJ-1040) is necessary for the installation of the FAX unit (GD-1220/1221).

Be sure to use the FAX unit and the equipment only in the following combinations.

	GD-1220	GD-1221	Remarks
e-STUDIO165/205	Available	N/A	
e-STUDIO167/207/237	Available	Available *	* The system firmware version of the equipment is T286SY*210 or later.

1.2 Specifications

1) Main system

- Type
Desktop type transceiver

- Operation
Transmission Manual/Automatic
Reception Manual/Automatic

2) Scanner

<Scanning density> []: at rotation transmission

- Horizontal direction
16 lines/mm, 8 lines/mm
[15.4 lines/mm, 7.7 lines/mm, 3.85 lines/mm]

- Vertical direction
15.4 lines/mm, 7.7 lines/mm, 3.85 lines/mm
[16 lines/mm, 8 lines/mm]

- Combination
U-Fine: 16 x 15.4 lines/mm [15.4 x 16 lines/mm]
Fine: 8 x 7.7 lines/mm [7.7 x 8 lines/mm]
Normal: 8 x 3.85 lines/mm [3.85 x 8 lines/mm]

- Effective scanning area
Standard mode

(For NAD model)

Horizontal scanning: Max. 280 mm (Ledger width)
Vertical scanning: Max. 432 mm (Ledger length)

(For MJD, AUD, ASD, SAD, TWD, and CND models)

Horizontal scanning: Max. 297 mm (A3 width)
Vertical scanning: Max. 420 mm (A3 length)

Long original mode

(For NAD model)

Horizontal scanning: Max. 280 mm (Ledger width)
Vertical scanning: Max. 1000 mm

(For MJD, AUD, ASD, SAD, TWD, and CND models)

Horizontal scanning: Max. 297 mm (A3 width)
Vertical scanning: Max. 1000 mm

Note:

The maximum vertical scanning length is 700 mm when transmission is performed satisfying all of the following conditions. The equipment is in the long original mode. Direct transmission is performed. The original has the same width as of A3 or ledger. The receiving facsimile machine is capable of receiving originals with A4 only.

3) Transmission system

Circuits to be used: Subscriber line/FAX communication network (G3)

- Calling automatic transmission (including the sequential multi-address transmission)
- Calling automatic reception (polling reception)
- Called automatic transmission (polling transmission)
- Called automatic reception
- Calling manual transmission
- Calling manual reception
- Called manual transmission
- Called manual reception

Communication mode

High-speed mode (Toshiba original procedure mode)

G3 mode

ECM (Error Correction Mode)

Circuit carrier link equalization function

Embedded

Output level

-16 dBm to -8 dBm (The setting can be changed by "1 dB".)

Input level

-43 dBm to 0 dBm

(Level -55 dBm or lower cannot be detected)

Specifications of the communication mode

	High-speed mode (Toshiba original procedure mode)	G3 mode	ECM
Horizontal scanning density	8 dots/mm 16 dots/mm	Same as on the left	Same as on the left
Vertical scanning density	3.85 lines/mm 7.7 lines/mm 15.4 lines/mm	Same as on the left	Same as on the left
Encoding system	MH/MR/MMR/JBIG	MH/MR	MH/MR/MMR/JBIG
Transmission speed (image signal) and modulation method	14.4 k/12 k/9600 7200/4800/2400 bps Conformance to V.17/V.29/V.27 ter	Same as on the left	33.6 k/31.2 k/28.8 k/ 26.4 k/24 k/21.6 k/ 19.2 k/16.8 k/14.4 k/ 12 k/9600/7200/ 4800/2400 bps
Control signal	300 bps (V.21)	Same as on the left	1200 bps (V.34) 300 bps (V.21)
Procedure to control the transmission	Toshiba original procedure	T.30 conformance	Same as on the left

4) Recording system

- Recording method
Electrophotographic recording method by LSU (Laser Scanning Unit)
- Resolution
Horizontal density 16 dots/mm
Vertical density 15.4 lines/mm
- Recording paper size and the effective printing area

Unit: mm (inch)

Paper size	Dimension (width x length)	Printing area
A5-R	148 x 210	143 x 204.5
B5-R	182 x 257	177 x 251.5
B5	257 x 182	252 x 176.5
A4-R	210 x 297	205 x 291.5
A4	297 x 210	292 x 204.5
B4	257 x 364	252 x 358.5
A3	297 x 420	292 x 414.5
FOLIO	210 x 330	205 x 324.5
ST-R	139.7 x 216 (5.5 x 8.5)	134.7 x 210.5
LT-R	216 x 279.4 (8.5 x 11)	211 x 273.9
LT	279.4 x 216 (11 x 8.5)	274.4 x 210.5
LG	216 x 355.6 (8.5 x 14)	211 x 350.1
LD	279.4 x 431.8 (11 x 17)	274.4 x 426.3
COMP	257 x 356 (10.125 x 14)	252 x 350.5

1.3 Features

- **High-speed scanning**
The GD-1220/1221 scan one Letter (A4) size Original page in 1.4 seconds (line density 8 dots/mm x 3.85 lines/mm) and stores it into memory.
- **High-speed transmission**
The GD-1220/1221 uses a V.34 modem designed for 33,600 bps communications.
- **Multi-access**
Using the multi-access facility, multiple processes can be performed in parallel. Functions, such as transmission reservation during reception, copying during memory transmission/ reception, etc. Maximizing the GD-1220/1221's high-speed scanning and multi-access capabilities provides maximum office productivity and efficiency. Patterns of the multi-access are as follows:
 - Scan to Memory during Memory Transmission
 - Scan to Memory during Reception
 - Scan to Memory during Substitute Reception
 - Copying during Memory Transmission
 - Reception during Copying
 - Reception during Memory printing
 - Reception during List printing
 - Scan to Memory during Memory printing
 - Scan to Memory during List printing
- **Laser recording on plain paper**
Recording is performed on fixed sizes of paper - Ledger, Legal, Letter, Letter-R, Statement, Statement-R, Computer, A4, A4-R (to NAD model) or A3, A4, A4-R, A5-R, B4, FOLIO, Letter, Letter-R (to MJD/AUD/ASD/SAD/TWD/CND models) - using a laser beam printer.
- **Halftone system**
Photographic images are clearly recorded by the 256 grayscales using the error diffusion method.
- **High resolution mode**
The GD-1220/1221 can transmit in ultra-fine mode (406 x 392).
- **Image memory communication function**
Picture data can be stored in the image memory. For a delayed transmission, the picture data created by scanning Originals is stored in the image memory and to be transmitted at the designated time.
Other memory functions include multi-address transmission, substitute reception, ECM communication, etc.
The memory contents will be retained by a backup battery for up to 2 hours if a power failure occurs. The memory size is 5.7 MB.
- **75 one touch keys**
The remote party's address data can be registered to a one touch key. Communication options can be registered for each address. Some one touch keys also operate as direct function access keys.
- **300 abbreviated dial numbers**
300 abbreviated dial numbers can be assigned in the range from No. 001 to 999.

- **Alternate number dialing**
It is possible to assign two facsimile telephone numbers to one abbreviated dial number or one touch dial key (one as the primary telephone number and the other as an alternate telephone number). The facsimile first dials the primary telephone number, then redials if the line is busy until the redialing limit count is reached. It will then begin to dial the alternate number. (Except for Relay/Mailbox/Confidential/Polling)
- **Multi-address transmission function**
Transmissions of the same original to multiple addresses (up to 375 addresses) are possible using one operation sequence, in which preset abbreviated dial numbers (300), and one touch dial keys (75) can be used. When the multi-key is specified, key pad dialing of up to 100 locations, is also possible.
- **Multi-polling reception**
Polling receptions from multiple remote parties (up to 375 parties) are possible using one operation sequence, in which preset abbreviated dial numbers (300), and one touch dial keys (75) can be used. When the multi-key is specified, key pad dialing of up to 100 locations, is also possible.
- **Relay transmission request function**
The GD-1220/1221 can originate a relay transmission or serve as a relay station in relay transmission transactions.
- **Secure RX**
Secure RX allows reception to memory to secure Originals during unattended periods. The user can select a specific time period and all day (24-hour) operation on selected days. The feature can be activated and deactivated by using a 4-digit security code.
- **Memory transmission**
Allows you to dial the remote party while scanning the original in memory. The original page data is cleared as the sending of each page is completed. Therefore, the memory is utilized effectively for transmissions. A maximum of 100 jobs of memory transmission are possible.
- **Public fax box**
An original can be reserved in image memory to be polled by remote stations multiple times. One of its merits is that any remote station (even one with a non-TOSHIBA facsimile) can poll such originals without a password.
- **Program continuous polling**
By designating the starting interval, time, and day-of-week, an endless polling can be set. Once set, polling receptions are repeated at the same time on the designated day-of-week.
- **Sub-address communication**
The GD-1220/1221 support communication applications using sub-address (SUB/SEP/PWD) commands conforming to ITU-T. Sub-address communication is possible by keypad dialing, one touch key dialing, and abbreviated dialing using the sub-address settings in Comm. Options.
- **Security communication**
For transmissions, the facsimile checks if the telephone number of the remote party's facsimile CSI matches the number dialed on the unit itself. If it matches, the transmission will start. For receptions, the facsimile checks if the telephone number of the remote party's TSI matches any number assigned to an abbreviated dial number or one touch key. If it matches, the reception will start. Thus transmissions or receptions with any authorized party will be prevented at the earliest stage.

- **Substitute reception into memory**
When there is no paper remaining in the drawer(s), when a recording paper jam occurs, the toner is empty, or printing is already in progress, the received data is stored into memory instead of being output to recording paper. When the trouble is corrected, or the active printing job is completed, the received data in memory will then be printed.
- **Communication options**
If necessary, the function may be changed and options can be selected for page number, line monitoring, turnaround polling, ECM communication and security transmission, etc.
- **Automatic dialing functions**
 - **Dialing with a time designated**
Transmitting a original to a designated party at a designated time.
 - **Redialing**
When an automatic dialing has been performed and the destination party is busy, redialing will be repeated as many times as programmed with a certain time interval also programmed.
- **Cover sheet function**
This facsimile has a facsimile cover sheet preparation feature built in, allowing the operator to enter the destination name, sender name at the time of the original transmission. This cover sheet also allows image data, such as a company logo, to be included.
- **Account code**
By entering a different account code for each destination at the time of transmission, account codes will identify when, for whom, and to whom a particular facsimile message was sent.
- **Department code**
Permits assigning 99 department codes to control access and track activity. These codes are set up beforehand, and must be used to access machine functions.
- **Separator page function**
GD-1220/1221 have the feature which divide print jobs (received original) using separator page. Also the customer can program the specified paper drawer for this function.
- **List output**
This allows the operator to print data stored in the memory (reservation list, preset dial number lists, function list, communication journal, transmission report, etc.).
- **Power saver mode**
This feature turns off virtually all power to minimize power consumption. Only the sub-MPU remains operation sensing for ringing signals, original insertion, or activation of the [ENERGY SAVER] key.
- **Sleep mode**
Reduces power consumption by cutting off power for the fuser during periods when printing is not expected. The fast warm up time ensures the printer section will be ready before a full page of image data can be received.
- **Recovery transmission**
Originals that have gone through the redial count limit will not be cleared, but stored for a programmed period of time. Such originals can be recovered to be transmitted again.
- **F-code mailbox/relay box communication**
Bulletin board F-code mailbox transmissions using ITU-T standard protocol is possible. Permitting confidential communications with any other similarity equipped facsimile made by TOSHIBA or some other company.

1.4 Accessories and Parts

The following accessories and parts come with the FAX unit:

Accessory	Qty
Operator's manual (for facsimile function): except TW, EU	1 pc.
Modular cord (2 m)	1 pc.
Unpacking instruction	1 set

Parts	Qty
Fax unit	1 pc.
SG3 label	1 pc.
FCC Part 68 label (U.S.A.): NA only	1 pc.
IC label (Canada): NA only	1 pc.
DTS label (EU): EU only	1 pc.
Teleprompt label (New Zealand): AU only	1 pc.
Notice to users label (New Zealand): AU only	1 pc.
Screw	2 pcs.

* Apply the each label to the specified positions following the Unpacking/Setup Instruction.

1.5 Options

Extends the FAX functions when the FAX unit is installed.

Option	Function	Model
Platen Cover	Holds originals	KA-1640PC
Automatic Document Feeder (ADF)	Feeds originals	MR-2017
Reversing Automatic Document Feeder (RADF)	Feeds originals	MR-3019
External Keyboard	Various dialings	GJ-1040

* The external keyboard (GJ-1040) is necessary for the installation of the FAX unit (GD-1220/1221).

1.6 System List

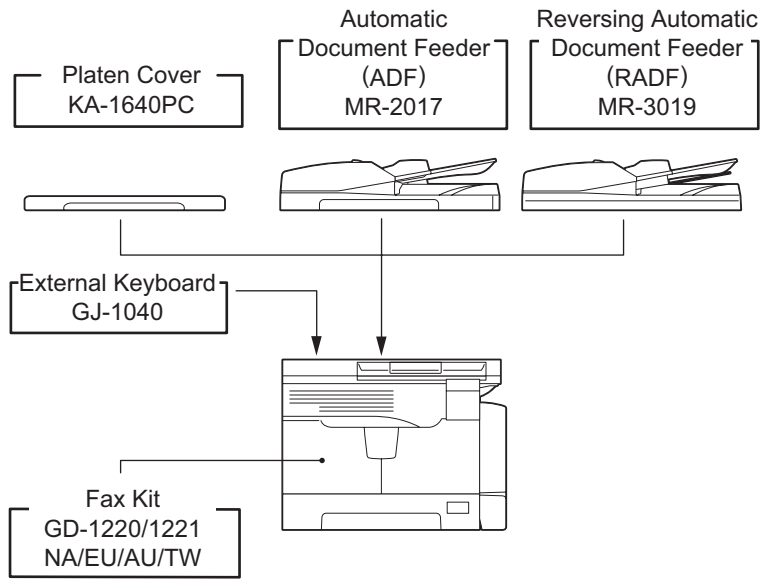

Fig. 1-1

1.7 Units and Components

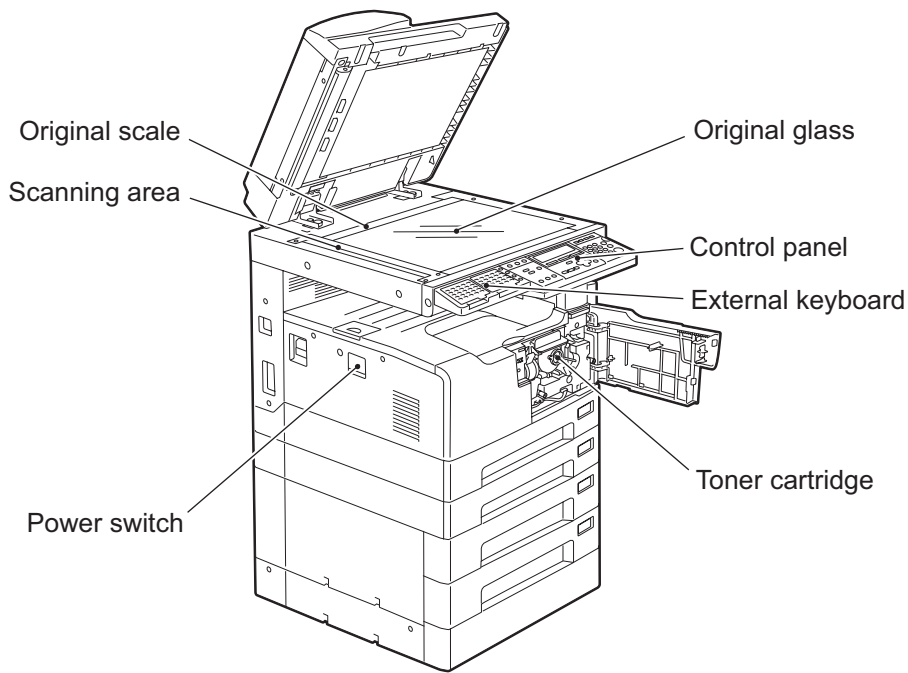

Fig. 1-2

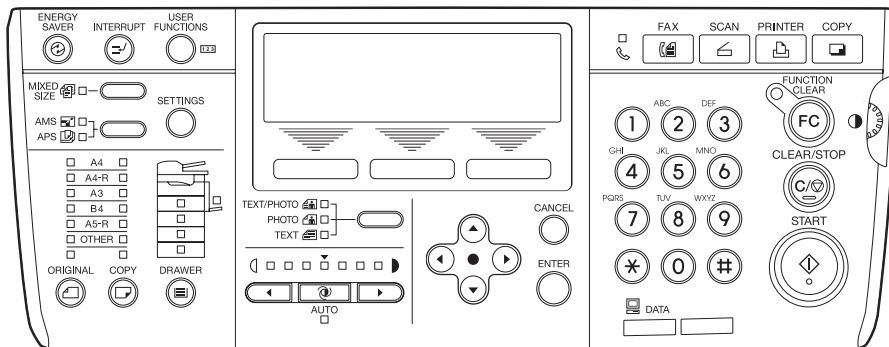

Fig. 1-3

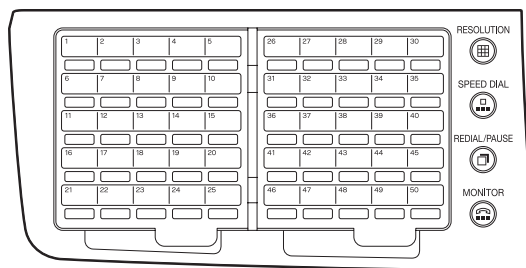

Fig. 1-4

1.8 Layout of PC Boards

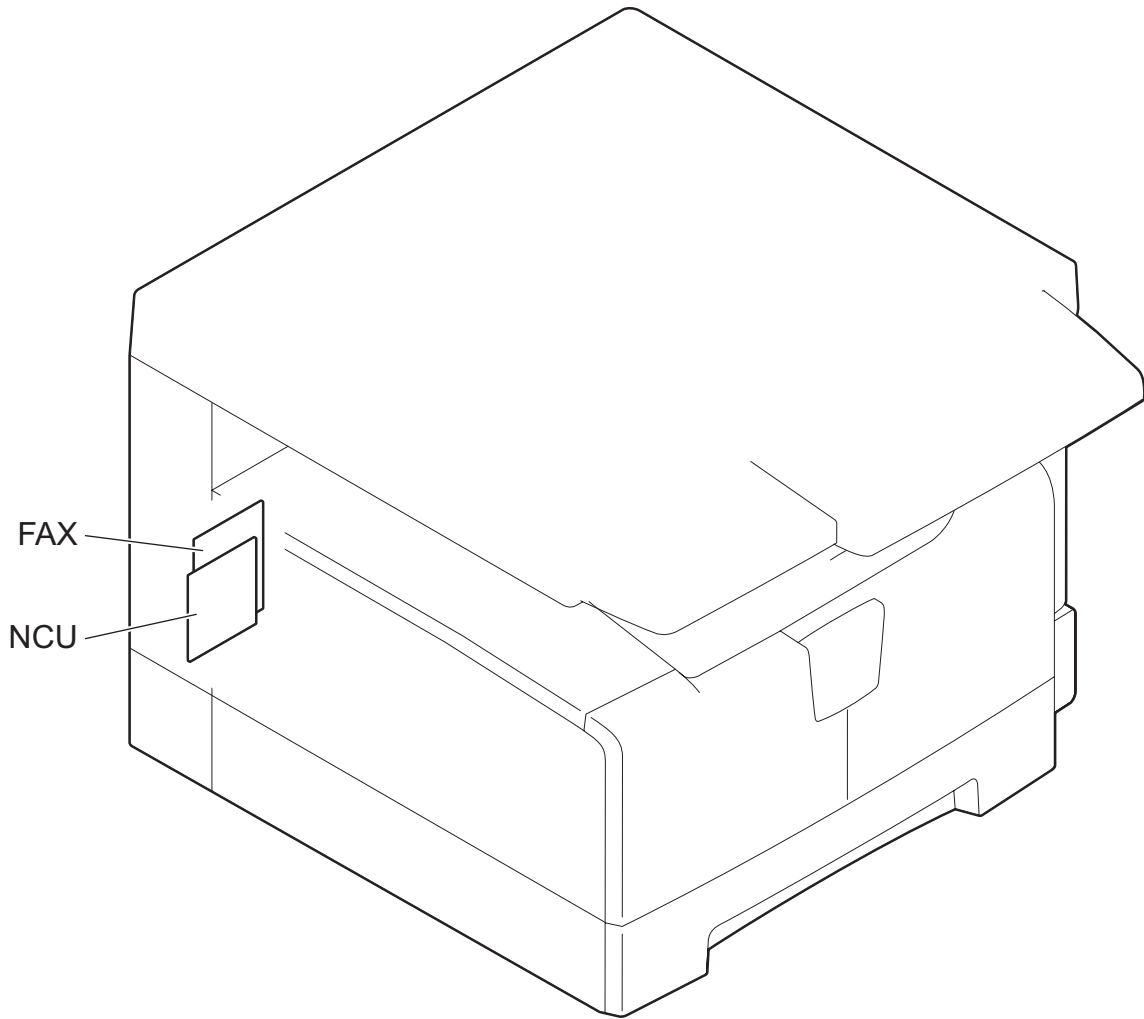

Fig. 1-5

Symbol	Name	Function
FAX	PWA-F-FAX-635 (GD-1220) PWA-F-FAX-678 (GD-1221) FAX board	Controls the FAX function
NCU	PWA-F-NCU-631 NCU board	Control the line of telephone

2. LSU-RELATED FUNCTIONS

2.1 Recording paper size

The following recording paper sizes can be used:

(For NAD model) : LD, LG, LT, LT-R, ST-R, COMP, A4, A4-R

(For MJD, AUD, ASD, SAD, TWD, CND models): A3, A4, A4-R, A5-R, B4, FOLIO, LT, LT-R

2.2 Effective recording area

1) Head : 4 mm (0.16 inch)

2) Foot : 4 mm (0.16 inch)

3) Effective Recording Limits:

For NAD model

[Unit: mm (inch)]

Paper size	Size (Horizontal x Vertical)	Effective recording area
LD	279 x 432 (11 x 17)	275 x 424 (10.8 x 16.7)
LG	216 x 356 (8.5 x 14)	212 x 348 (8.3 x 13.7)
LT	279 x 216 (11 x 8.5)	275 x 208 (10.8 x 8.2)
LT-R	216 x 279 (8.5 x 11)	212 x 271 (8.3 x 10.7)
ST-R	140 x 216 (5.5 x 8.5)	136 x 208 (5.4 x 8.2)
COMP	257 x 356 (10.125 x 14)	253.2 x 348 (9.97 x 13.7)
A4	297 x 210	293 x 202
A4-R	210 x 297	206 x 289

For MJD, AUD, ASD, SAD, TWD, and CND models

[Unit: mm (inch)]

Paper size	Size (Horizontal x Vertical)	Effective recording range
A3	297 x 420	293 x 412
A4	297 x 210	293 x 202
A4-R	210 x 297	206 x 289
A5-R	148 x 210	144 x 202
B4	257 x 364	253 x 356
FOLIO	210 x 330	206 x 322
LT	279 x 216 (11 x 8.5)	275 x 208 (10.8 x 8.2)
LT-R	216 x 279 (8.5 x 11)	212 x 271 (8.3 x 10.7)

2

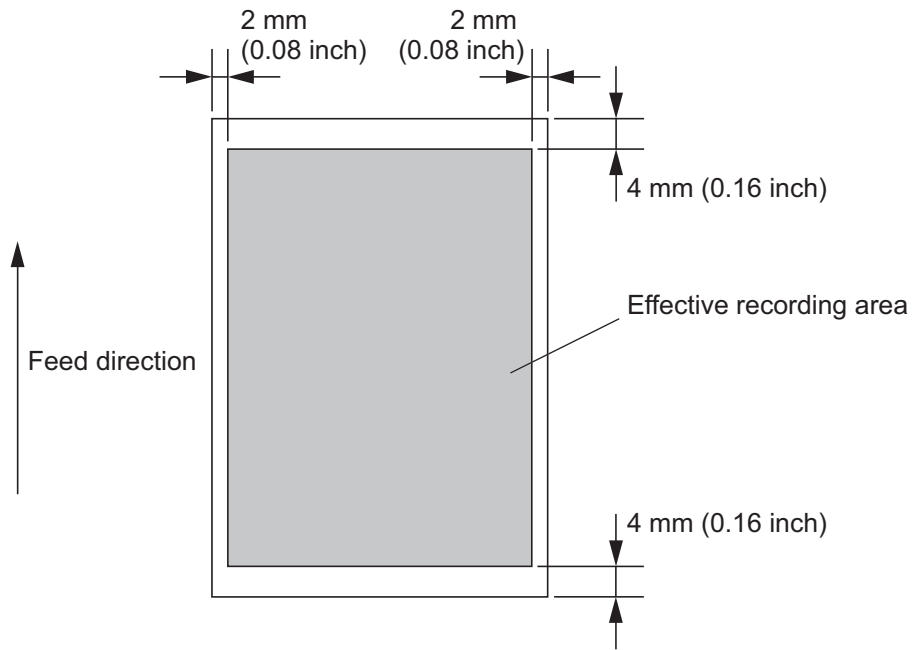

Fig. 2-1

2.3 Print mode

The machine provides various print modes to meet various requests from users, such as applicable recording paper types, recording methods, etc.

2.4 Recording paper selection algorithm and print algorithm

2.4.1 Recording paper selection algorithm

Capable of identifying the above-mentioned recording paper size of a received image, this machine prints on the recording paper of the same size as when sent, as a rule. If no recording paper of the identified size is not available, it selects recording paper for printing according to the set mode. The mode is set by using Func. 15 bit 3.

- 1) Automatic reduction mode (Func. 15 bit 3 = 0, Default)
Selects recording paper on which the received document can be printed and prints on it.
- 2) Reduction OFF mode (Func. 15 bit 3 = 1)
Selects recording paper on which the received document can be printed in a full size.

2.4.2 Print algorithm

A reception print image is basically printed on one page. Consequently, the algorithm of reception print is in the order of same size print, discard extra, vertical reduction print, and divided print. (Refer to the reception print flowchart.)

Reception print flowchart

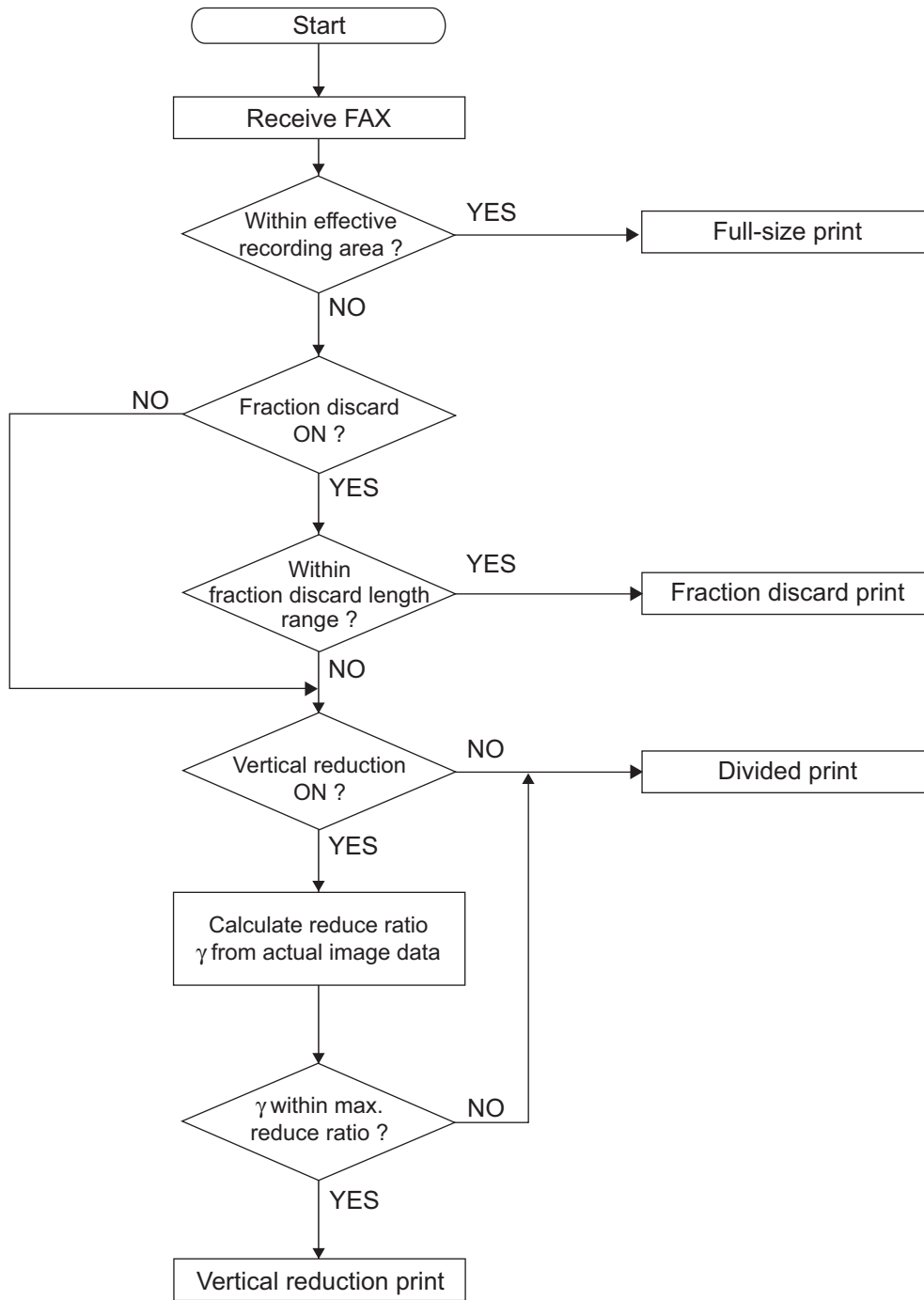

Judgment parameter	
Effective recording area	Area excluding 4 mm from the top of recording paper and 4 mm from the bottom.
Discard	Function setting by user
Vertical reduction	Function setting by user
Discard parameter	Func. 15 bit 6, 7

[1] Discard printing

Func. 15 bit 2 permits selecting between ON and OFF of the option for discard extra.

Func. 15 bit 2 = 0 : OFF

Func. 15 bit 2 = 1 : ON (Default)

Func. 15 bits 6 and 7 allow the discard parameter to be set.

Func. 15 (Default Setting bit 2 = 0, bit 6 = 1, bit 7 = 0)

bit 2	bit 6	bit 7	Discard parameter
0	X	X	Discard OFF
1	0	0	0 mm (Discard OFF)
1	1	0	10 mm
1	0	1	17 mm
1	1	1	34 mm

- When the option for discard extra is ON:
When the length of the received document in the feed direction exceeds the effective recording area and the part exceeding one page is within the discard parameter, printing takes place with the exceeding part discarded. When the length of the received document in the feed direction exceeds the discard parameter range and is within the reduction range of the maximum reduce ratio, vertical reduction print takes place. When it is not within the reduction range of the maximum reduce ratio, divided print takes place. The discard extra takes preference over the vertical reduction print.

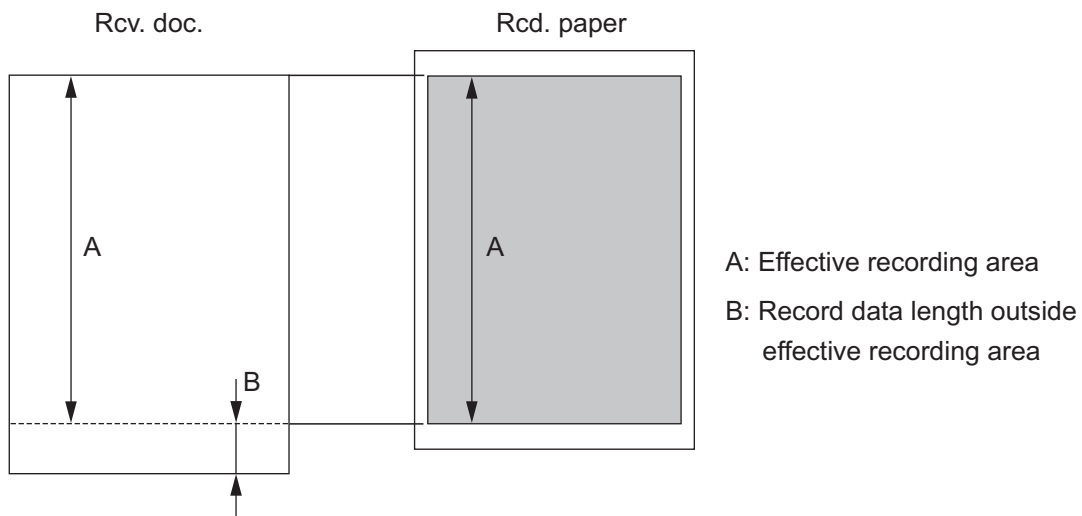

Fig. 2-2

If the length of B is less than the set discard parameter, B is discarded.

- When the option for discard extra is OFF:
The vertical reduction takes preference without performing discard extra print.

[2] Vertical reduction print

Func. 15 bit 5 permits selecting between ON and OFF of the option for Vertical reduction print.

Func. 15 bit 5 = 0 : OFF

Func. 15 bit 5 = 1 : ON (Default)

- When the option for Vertical reduction print is ON:
When the length of the received document in the feed direction exceeds the effective recording area, the feed length is reduced in an appropriate reduce ratio and then the received document is printed on one sheet of recording paper.
The following two patterns of maximum reduce ratio are available according to the setting of Func. 15 bit 1.
Func. 15 bit 1 = 0 : Max. reduce ratio 90 % → The reduce ratio settings of 95% and 90 % are valid.
Func. 15 bit 1 = 1 : Max. reduce ratio 73 % → The reduce ratio settings of 95 %, 90 %, 86 %, 80%, 83 % and 73 % are valid.
- When the option for vertical reduction print is OFF:
When the length of the received document in the feed direction exceeds the effective recording area, divided print takes place.

[3] Divided print

When received data cannot be recorded on one sheet, even if reception reduction and reception discard are carried out, the recorded data is divided in the vertical direction and printed on two or more sheets with maximum length set up in the equipment, without reduction.

If a long original with length of 216 mm which cannot be recorded on one B4 sheet with the maximum reduction is received, when A4, B4, and A5 paper is loaded in the first, second, and third drawers, respectively, for example, the maximum recording paper (B4) is selected and received data is divided and printed on two or more sheets without reduction. (Refer to  P. 2-13 " Table 3 Selection of recording paper (Long original)".)

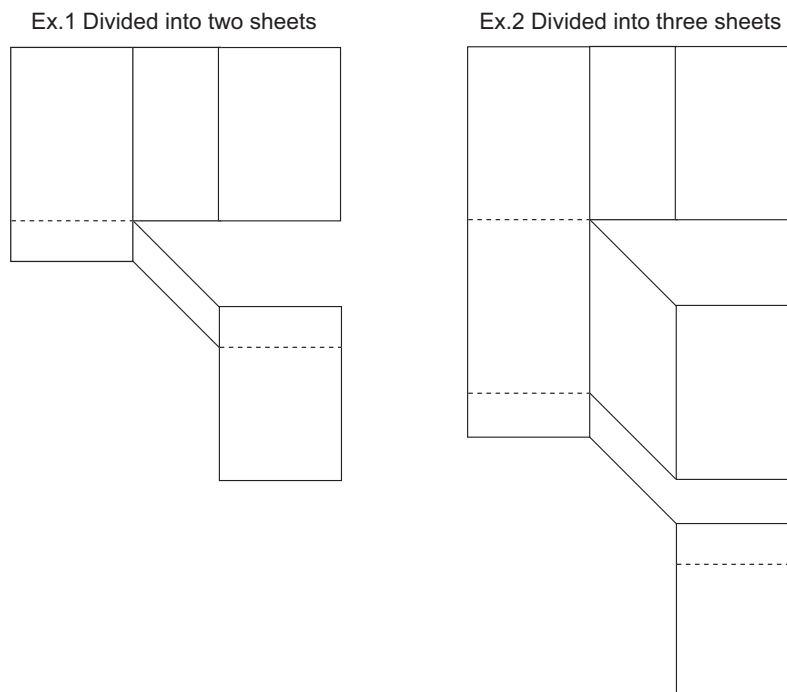

Fig. 2-3

[4] Similar reduction print

When recording paper of the same size as that of the received document is not available due to running out of paper or no paper is available to cover the received document, the received document is similarly reduced and printed on recording paper smaller than the received document.

Ex.1 To print A3-size received document on an A4-R sheet because of running out of paper.

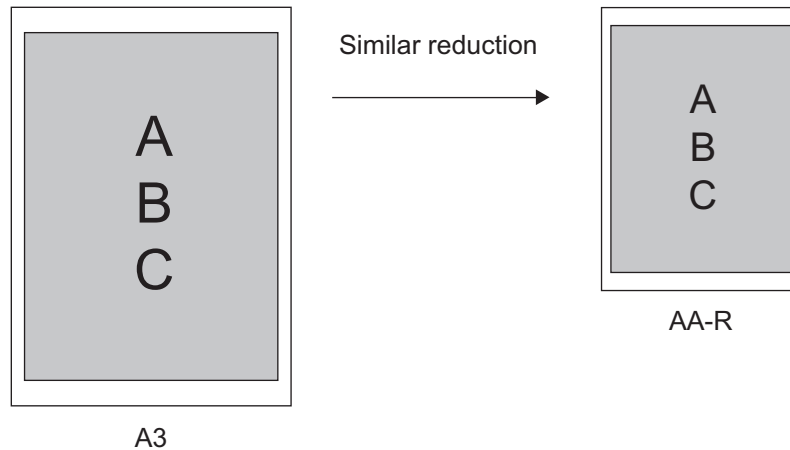

Fig. 2-4

[5] Rotation print

When recording paper of the same size as that of the received document exists but the orientations are different on those sheets, the received document is rotated by 270 degrees before being printed. The rotation function is performed after discard extra, reduction or dividing processing. The rotation function is valid for received documents of A4, LT, A5, and ST-R sizes.

[6] Printing with no recording paper

When recording paper has run out during printing, printing takes place on another printable recording paper starting from the next page, if available. However, if recording paper has run out in the middle of divided print, reprinting takes place on another recording paper starting from the first one of the divided pages. (The same operation is done when recording paper of the same size is set in a different paper drawer.)

For the selection order of recording paper, refer to  P. 2-12 " Table 2 Selection of recording paper".

[7] RTI

When printing a received document with the RTI setting ON, RTI is printed on each page but RTI is printed on the first page only in the case of divided print.

(ON or OFF of RTI is possible by means of the user setting. Default: OFF) RTI is created for the LT or A4-R width. When printing RTI on A5, B5 and ST-R smaller than those sheets, the information to be printed is reduced to a printable length.

- LT size or up

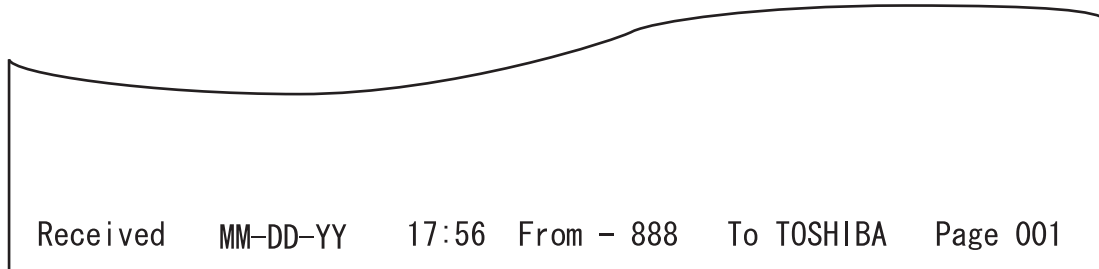

Fig. 2-5

- A5, B5, ST-R

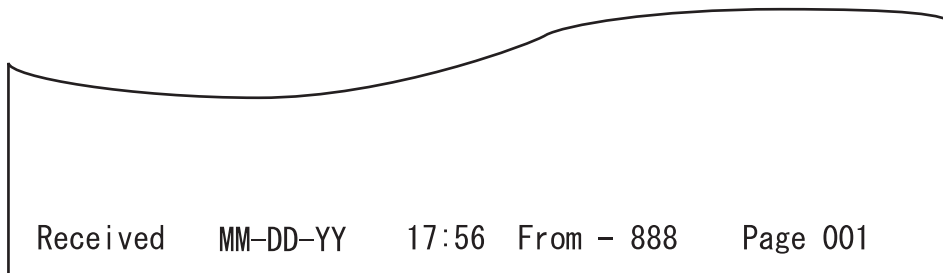

Fig. 2-6

[8] Received document and selection of recording paper

The procedure for selecting recording paper handled by this machine is briefly described below.

Recording paper for reception print is selected according to the print recording paper range and priority as listed in Table 2. A printable print recording paper range is selected according to the scanning width and feed length of the received document. A print recording paper range is selected by taking the discard length and feed reduce ratio into consideration.

Shown is an example where an EU model is used, the discard parameter is 10 mm, the feed reduce ratio is max. 75 %, the scanning width of the received image is A4, the number of lines received is STD or 2000 lines. Since the scanning width is A4, the recording paper range to be selected is one of A5-R, A4-R, FOLIO, B4 and A3.

Since 2000 lines are converted to 519 mm, a feed length to allow 390 mm to be printed on one page with a max. reduce ratio of 75 % is selected. The recording paper length of A4 is 297 mm, the recording paper length of B4 is 364 mm, and the recording paper length of A3 is 420 mm.

Therefore, an A3 paper range covering 390 mm is selected. After an A3 range is selected, recording paper is selected according to the priority in Table 2, followed by printing.

Table 1 Selection of recording paper range

For NAD model

		Scanning		
		216 mm	256 mm	303 mm
Feed length	ST (140 mm)	ST-R	COMP	LT
	LT (216 mm)	LT-R	COMP	LT
	LT-R (279 mm)	LT-R	COMP	LD
	LG/COMP (356 mm)	LG	COMP	LD
	LD (432 mm)	LD	LD	LD
	Long original (over 432 mm)	LT (long)	COMP (long)	LD (long)

For MJD, AUD, ASD, SAD, TWD, CND models

		Scanning width		
		216 mm	256 mm	303 mm
Feed length	A5 (148.5 mm)	A5-R	B5	A4
	B5 (182 mm)	A4-R	B5	A4
	A4 (210 mm)	A4-R	B4	A4
	A4-R (297 mm)	A4-R	B4	A3
	FOLIO (330 mm)	FOLIO	B4	A3
	B4 (364 mm)	B4	B4	A3
	A3 (420 mm)	A3	A3	A3
	Long original (over 421 mm)	A4 (long)	B4 (long)	A3 (long)

* When there is no recording paper which received data can be printed on one sheet of, the maximum paper loaded in the equipment is selected and data is divided and printed on two or more sheets without reduction. (Refer to  P. 2-13 " Table 3 Selection of recording paper (Long original)".)

Table 2 Selection of recording paper

For NAD model

		Recording paper range					
		LT-R	LT	LG	COMP	LD	ST
Priority of recording paper	1	LT-R	LT	LG	COMP	LD	ST-R *3
	2	LT *3	LT-R *3	COMP *2	LD *2	COMP *1	LT-R
	3	LG	LD	LD *2	LT-R *1	LT-R *1	LT *3
	4	A4-R	LG *2*3	LT-R	LT *1*3	LT *1*3	LG
	5	A4 *3	A4	LT *3	LG *1	LG *1	A4-R
	6	COMP *2	A4-R *3	A4-R	A4-R *1	A4-R *1	A4 *3
	7	LD *2	COMP*2*3	A4 *3	A4 *1*3	A4 *1*3	COMP *2
	8	ST-R *1	ST-R *1*3	ST-R *1	ST-R *1	ST-R *1	LD *2

For MJD, AUD, ASD, SAD, TWD, and CND models

		Recording paper range						
		A4-R	B4	A3	A4	A5	FOLIO	B5
Priority of recording paper	1	A4-R	B4	A3	A4	A5-R *3	FOLIO	B4
	2	A4 *3	A3 *2	B4 *1	A4-R *3	A4-R	B4 *2	A4 *2
	3	FOLIO	A4-R *1	A4-R *1	A3	A4 *3	A3 *2	A4-R *2*3
	4	LT-R	A4 *1*3	A4 *1*3	FOLIO*2*3	FOLIO	A4-R	A3 *2*3
	5	LT *3	FOLIO *1	FOLIO *1	B4 *2*3	LT-R	A4 *3	FOLIO *2*3
	6	B4 *2	LT-R *1	LT-R *1	LT	LT *3	LT-R	LT *2
	7	A3 *2	LT *1*3	LT *1*3	LT-R *3	B4 *2	LT *3	LT-R *2*3
	8	A5-R *1	A5-R *1	A5-R *1	A5-R *1*3	A3 *2	A5-R *1	A5-R *1*3

* 1 : Similar reduction possible.

* 2 : Center printing when printing out to a size larger in the scanning direction.

* 3 : Rotation processing.

Table 3 Selection of recording paper (Long original)

For NAD model

		Recording paper range		
		LT (long)	COMP (long)	LD (long)
Priority of recording paper	1	LD *2	LD *2	LD
	2	COMP *2	COMP	COMP *1
	3	LT-R	LT-R *1	LT-R *1
	4	LT *3	LT *1*3	LT *1*3
	5	LG	LG *1	LG *1
	6	A4-R	A4-R *1	A4-R *1
	7	A4 *3	A4 *1*3	A4 *1*3
	8	ST-R *1	ST-R *1	ST-R *1

For MJD, AUD, ASD, SAD, TWD, and CND models

		Recording paper range		
		A4 (long)	B4 (long)	A3 (long)
Priority of recording paper	1	A3 *2	A3 *2	A3
	2	B4 *2	B4	B4 *1
	3	A4-R	A4-R *1	A4-R *1
	4	A4 *3	A4 *1*3	A4 *1*3
	5	FOLIO	FOLIO *1	FOLIO *1
	6	LT-R	LT-R *1	LT-R *1
	7	LT *3	LT *1*3	LT *1*3
	8	A5-R *1	A5-R *1	A5-R *1

* 1 : Similar reduction possible.

* 2 : Center printing when printing out to a size larger in the scanning direction.

* 3 : Rotation processing.

2.5 Error processing

If paper has run out or a drawer has been pulled out, follow the procedure described below.

- 1) If recording paper of a larger size has run out during communication:
For DIS redeclaration in the mode change procedure, declare the first recording paper size declared, as it is.
- 2) If a document has been received with recording paper of a larger size empty:
Declare the maximum value of the remaining recording paper or the attached drawer. Conform to the setting of Func. 8 bit 4.
- 3) If the drawer has been pulled out:
Assume A4 if none of the drawers is left.
- 4) If all paper has run out:
When the recording paper width capacity is recording paper and all paper has run out, assume A4.
(Same processing is done when only the recording paper of scan width less than 216 mm is set.)

2.6 Limitations on reception print

The following limitations are imposed on reception print.

- 1) Reception print is not performed from the SFB.
- 2) Even if the ADU is installed, it cannot be used.
- 3) When illegal paper is selected and printed on due to an operator mistake, the completion of printout is assumed and no printout is performed again.
- 4) The feed length of a received document is not limited. That is, printing is performed even if the received document has several lines for printing. However, if the top lines are less than 5 lines, no printing takes place. This also applies to multiple pages in divided print.
- 5) Paper of the same size is present in multiple drawers, printing takes place according to the following drawer priority.

Order	Drawer
1	Drawer selected by code 480 in system mode
2	1st drawer
3	2nd drawer
4	3rd drawer
5	4th drawer

3. DIALING/COMMUNICATION CONTROL

3.1 Circuit Connection and Procedure to Change Mode

3.1.1 Dial call-up transmission to a telephone circuit

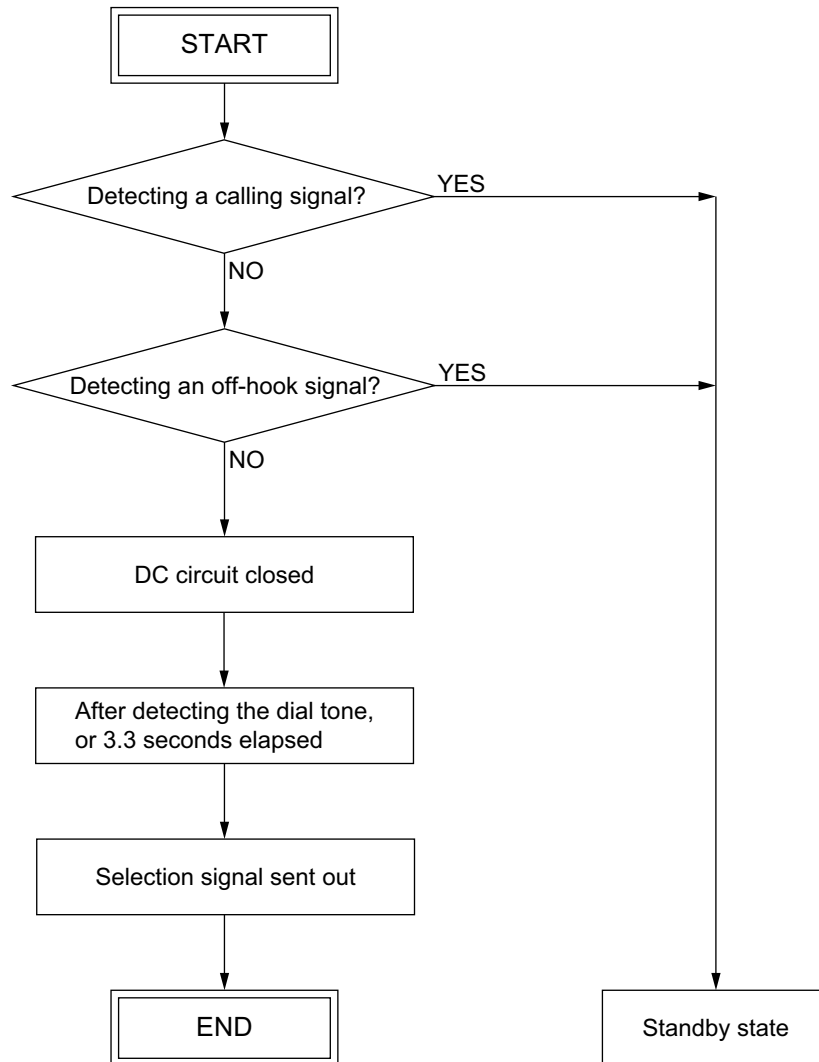

3.1.2 Selection of the communication mode

This machine has three types of communication mode. The mode to be used is determined according to the combination of the types of the circuits and communication and available function of the other side's machine.

	Communication mode		
	Toshiba original procedure	ECM	G3
Telephone circuit	○	○	○

3.1.3 Procedure to select the transmission mode

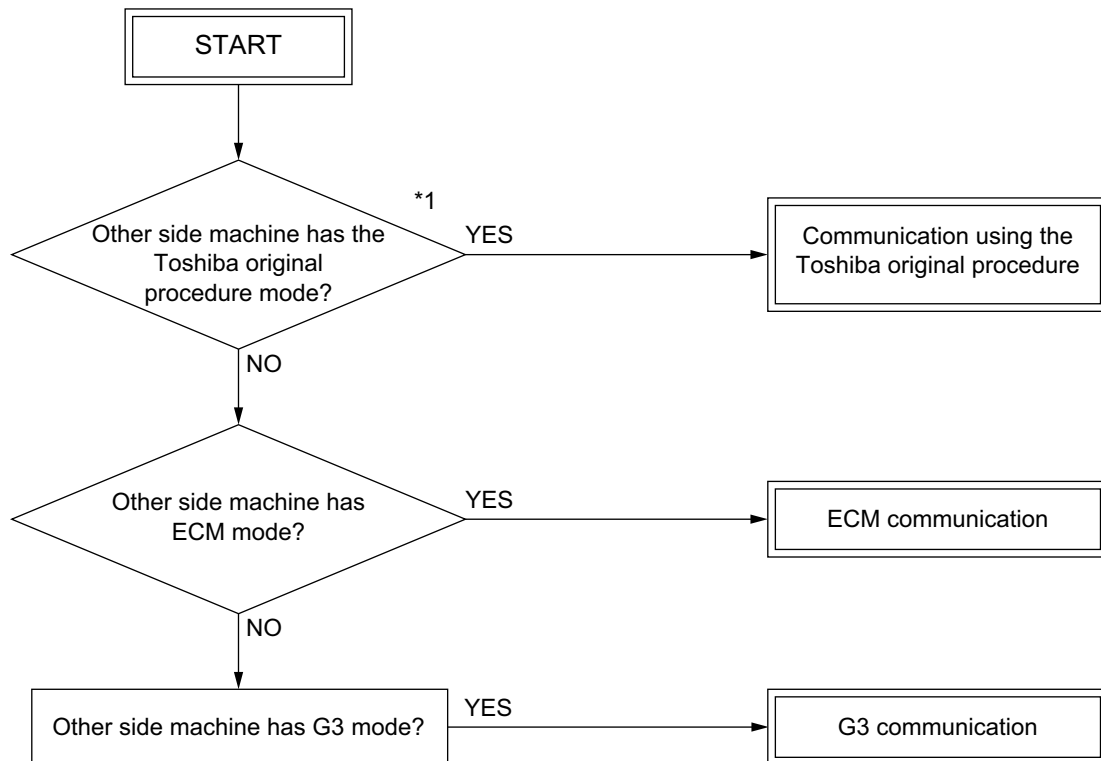

*1 This step is only checked when the other side machine has CRP2 (+ CRP1) or when the transmission is started by the CRP calling. (The first transmission to the other side with CRP1 only is performed in the ECM mode.)

3.2 Signaling System Diagram and Signal Forms

3.2.1 Circuit control signals

The following circuit control signals are used in the binary and tonal procedures.

- Circuit control signals

CED	Called station identification Indicates that the sender is a FAX machine in the automatic called mode. (*1)
CNG	Calling tone Indicates that the sender is a FAX machine in the automatic calling mode. (*1)

*1: This signal can be sent manually.

- Signal form

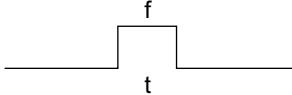
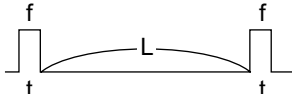
Signal name	Signal form	Signal form
CED		f: 2100 ±15 Hz t: 2.6 - 4.0 sec
CNG		f: 1100 ±38 Hz t: 0.5 sec ±15% (L: 3 sec)

3.2.2 Communication with the binary signals

In the Toshiba original procedure/G3 modes, communication is performed with the binary procedure as follows.

1) Binary procedure

- Transmission and reception in the Toshiba original procedure/G3 modes

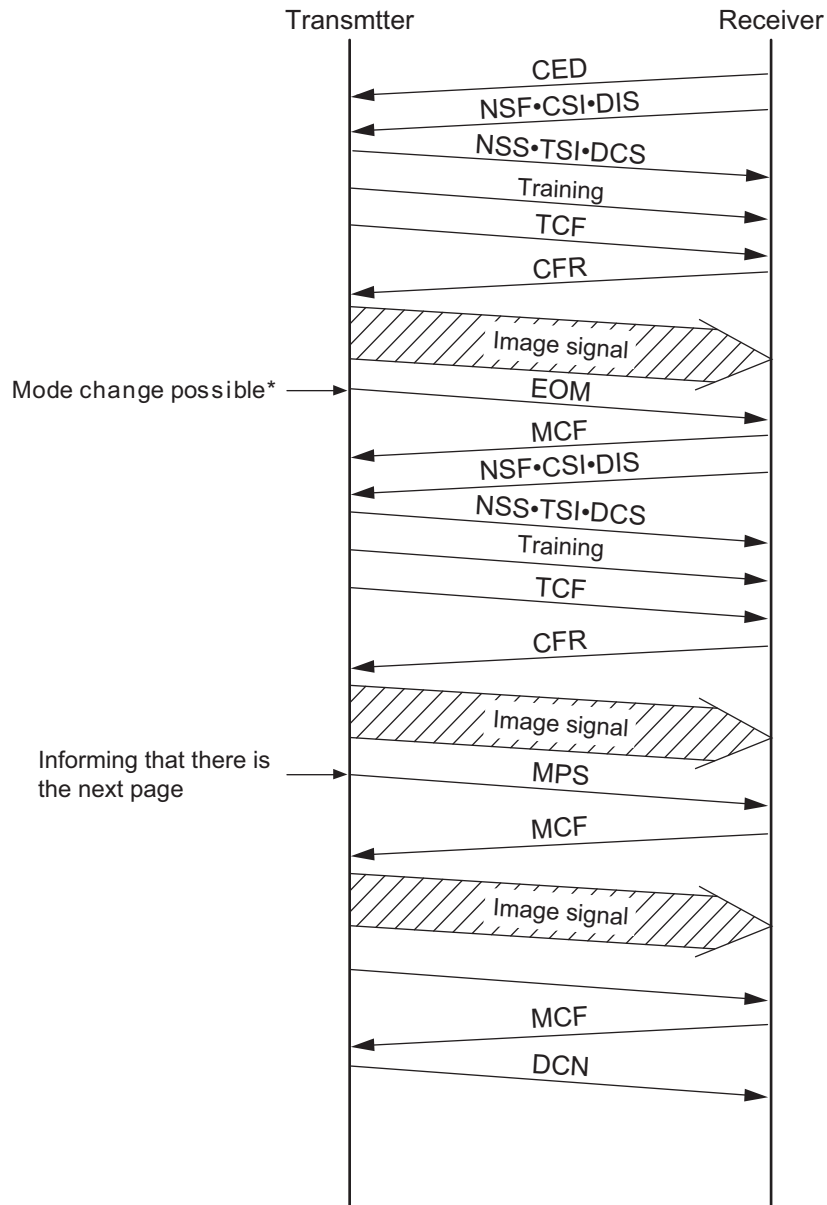

* Mode change is possible only for the original set manually.

- Transmission and reception in the ECM mode
ECM (Error Correction Mode) conforms to T.30.
When an error has occurred to the received image data, the receiving station informs the sending station of the occurrence of the error, and the sending station sends the image data again.

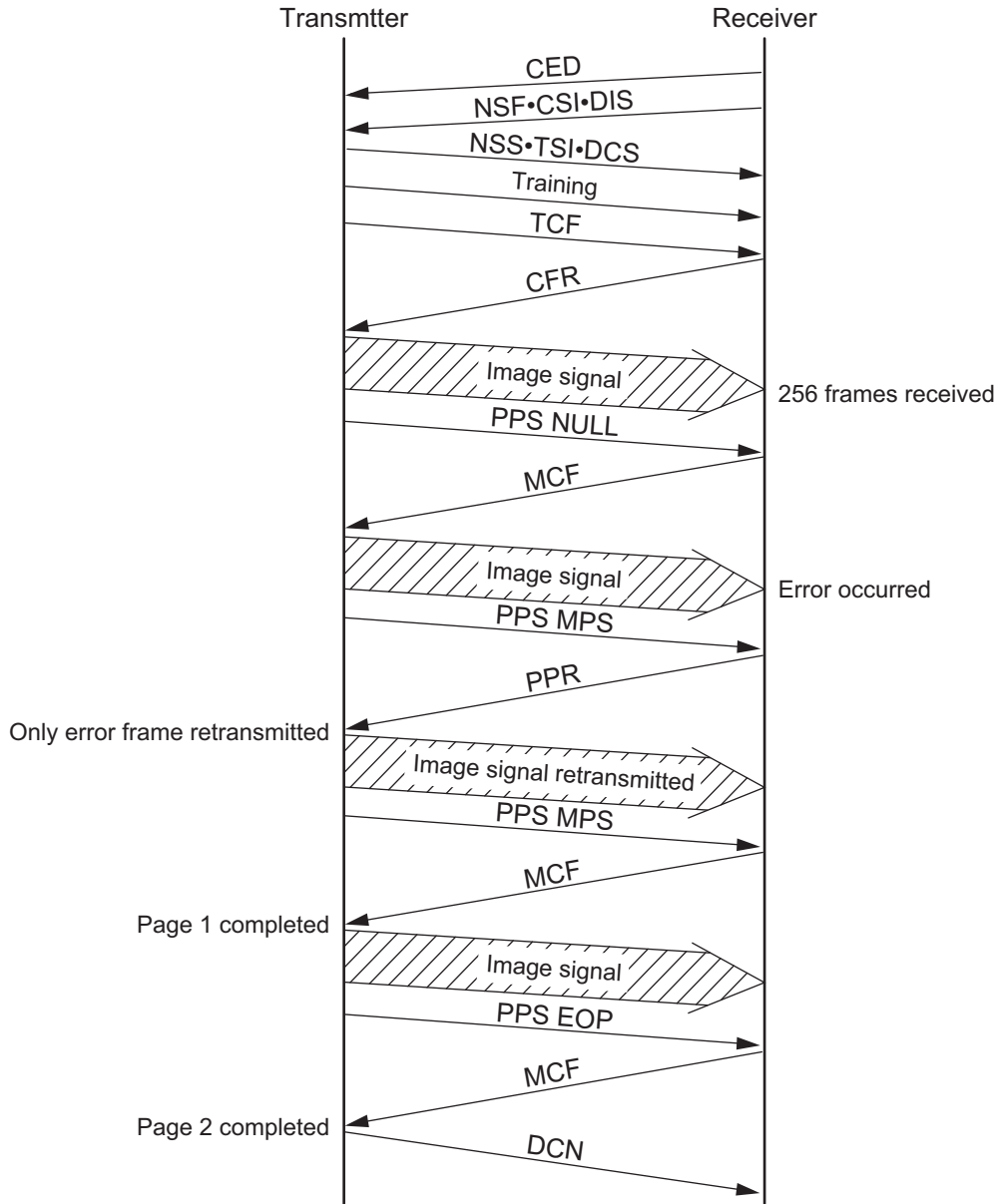

- Cancellation during the transmission

If the [CLEAR/STOP] button is pressed during the direct transmission or memory input, the display to confirm the cancellation appears. The communication is finished normally regardless of the presence/absence of the next page or mode changes by pressing the [CLEAR/STOP] button. If the [CLEAR/STOP] button is pressed anytime except during the transmission of the image data, DCN is forcibly sent to terminate the communication.

To cancel the job during the memory transmission or the polling transmission job, press the [JOB STATUS] button on the External Keyboard, select the transmission job to cancel, and then press the [◀] button on the LCD display.

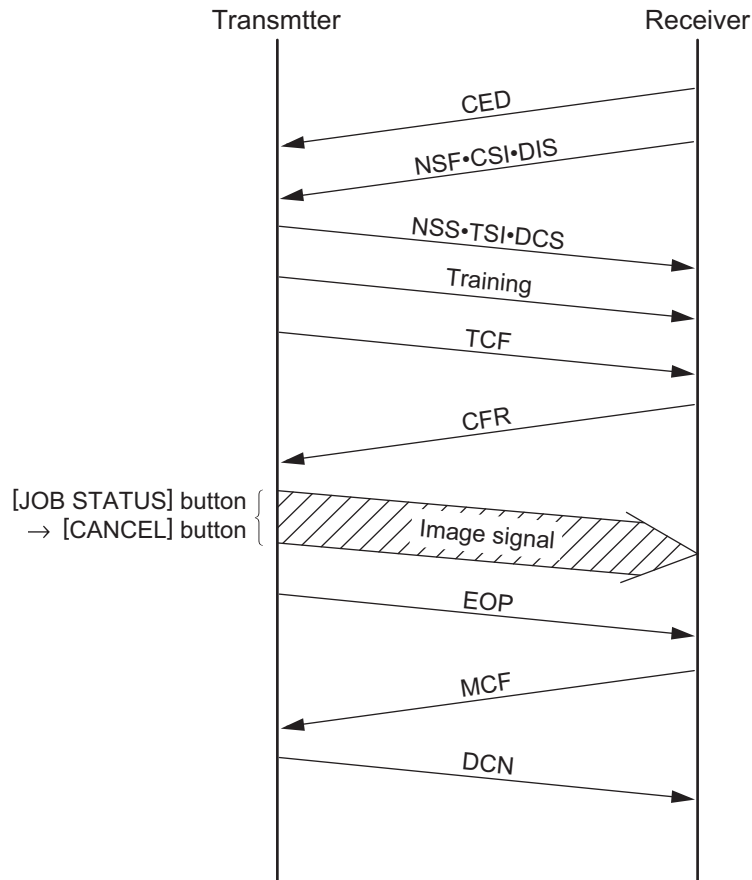

2) Binary signals

NSF	Non-Standard Facility Informs that the receiving station (machine) has a non-standard facility.
NSC	Non-Standard Facility Command Command to transmit using the non-standard facility which is selected corresponding to NSF (i.e., Polling etc.).
NSS	Non-Standard Facility Setup Command to transmit using the non-standard facility which is selected corresponding to NSF or NSC.
CSI	Called Subscriber Identification Provides the telephone number of the called station. Used to check the identity of the called station.
CIG	Calling Subscriber Identification Provides the telephone number of the calling station. Used to check the identity of the calling station (Polling, etc.).
TSI	Transmitting Station Identification Provides the telephone number of transmitting station. Used to check the identity of the transmitting station.
DIS	Digital Identification Signal Informs that the receiving station (machine) has a standard facility (G3/G2).
DTC	Digital Transmit Command Command to transmit using the standard facility which is selected corresponding to DIS (i.e., Polling, etc.).
DCS	Digital Command Signal Commands to transmit using the standard facility which is selected corresponding to DIS or DTC.
SUB	Sub-address Indicates that the FIF information is a sub-address in the domain on the call-in side.
SEP	Select Polling Indicates that the FIF information is a sub-address for the polling mode.
PWD	Password Indicates that the FIF information is a password for the polling mode in a reception. Indicates that the FIF information is a password for transmission in a transmission.
CFR	Confirmation of Reception Informs that the FAX is ready to receive data.
FTT	Failure to Train Informs that the TCF signal has not received correctly and requests the re-training.
EOM	End of Message Informs that the 1st page has been transmitted and there is the next page; command to return to the beginning of the phase B.
MPS	Multi-page Signal Informs that the 1st page has been transmitted and there is the next page; command to return to the beginning of the phase C.
EOP	End of Procedure Informs that a document has been transmitted and there is no more pages.
MCF	Message Confirmation A reply to MPS, EOM or EOP; informing that image signals have been received correctly and the FAX is ready to receive data.
RTN	Retrain Negative Informs that a document has not been received correctly; requests for the retraining or phase synchronization to receive the next page.

PIP	Procedure Interrupt Positive Informs that the image signals have been received correctly and requests the operator's reply by telephone or to return to the beginning of the phase B to continue the communication (i.e., CALL Request, etc.).
PIN	Procedure Interrupt Negative Informs that the image signals have not been received correctly and requests for operator's reply by telephone or to return to the beginning of the phase B to continue the communication.
PRI-EOM	Procedure Interrupt EOM Command similar to EOM. Operation by operator is necessary.
PRI-MPS	Procedure Interrupt MPS Command similar to MPS. Operation by operator is necessary.
PRI-EOP	Procedure Interrupt EOP Command similar to EOP. Operation by operator is necessary.
DCN	Disconnect Command to disconnect the FAX line and to connect the telephone line. Reply from the other side is not necessary.
RR	Receive Ready Informs that the FAX is ready to receive documents and requests for data to set the reception mode. (ECM mode)
RNR	Receive Not Ready Informs that the FAX is not in the receivable state. (ECM mode)
PPR	Partial Page Request Informs that a part of page (ECM block) has not been received correctly. The number of the frame needs to be corrected is informed by the FIF. (EC mode)
PPS	Partial Page Signal Informs that a part of page (ECM block) or one page has been transmitted. (EC mode)
CTC	Continue to Correct Replies to the 4th PPR which requests to correct the image signal; informs that the transmitting station will continue to correct the frame data. (ECM mode)
CTR	Response for Continue to Correct Replies to CTC and informs that the receiving station has received and accepted the CTC. (EC mode)
EOR	End of Retransmission Informs that the transmitting station has completed the correction of the error frame data (binary signal) of the previous ECM block. (ECM mode)
ERR	Response for End Retransmission Replies to EOR and requests to transmit the image signal of the next ECM block. (ECM mode)
RTP	Retrain Positive Informs that the message has been received completely and that the subsequent message can be continued after receiving the synchronization signal and CFR signal.
CRP	Command Repeat Requests to resend all the commands including optional frames because the preceding command has been received incorrectly.

3) Frame structure of binary signals

Each binary signal frame is comprised of the following sequence and fields. However, some binary signals do not have the FIF field inserted.

F	F	A	C	FCF	FIF	FCS	F
---	---	---	---	-----	-----	-----	---

Preample

F : Flag sequence
Indicates the start or end of a frame. Also establishes the frame synchronization.

A : Address field
Informs the address.

C : Control field
Informs if this frame is the last one in this procedure.

FCF: FAX control field
Informs the type of the binary signal.

FIF: FAX information field
Informs FAX information such as the functions.

FCS: Frame check sequence
Checks if there was any error in the transmission from A to FIF.

- Format of F, A and C

	Format							
	b ₁	b ₂	b ₃	b ₄	b ₅	b ₆	b ₇	b ₈
F	0	1	1	1	1	1	1	0
A	1	1	1	1	1	1	1	1
C	1	1	0	0	x	0	0	0

* When this frame is the last frame, X = 1.

- FCF format of each binary signal

Binary signal	Format							
	b ₁	b ₂	b ₃	b ₄	b ₅	b ₆	b ₇	b ₈
NSF	0	0	0	0	0	1	0	0
NSC	1	0	0	0	0	1	0	0
NSS	x	1	0	0	0	1	0	0
CSI	0	0	0	0	0	0	1	0
CIG	1	0	0	0	0	0	1	0
TSI	x	1	0	0	0	0	1	0
DIS	0	0	0	0	0	0	0	1
DTC	1	0	0	0	0	0	0	1
DCS	x	1	0	0	0	0	0	1
SUB	x	1	0	0	0	0	1	1
SEP	1	0	0	0	0	1	0	1
PWD(Rx)	1	0	0	0	0	0	1	1
PWD(Tx)	x	1	0	0	0	1	0	1
CFR	x	0	1	0	0	0	0	1
FTT	x	0	1	0	0	0	1	0
EOM	x	1	1	1	0	0	0	1
MPS	x	1	1	1	0	0	1	0
EOP	x	1	1	1	0	1	0	0
MCF	x	0	1	1	0	0	0	1
RTN	x	0	1	1	0	0	1	0
PIP	x	0	1	1	0	1	0	1
PIN	x	0	1	1	0	1	0	0
PRI-EOM	x	1	1	1	1	0	0	1
PRI-MPS	x	1	1	1	1	0	1	0
PRI-EOP	x	1	1	1	1	1	0	0
DCN	x	1	0	1	1	1	1	1
RR	x	1	1	1	0	1	1	0
RNR	x	0	1	1	0	1	1	1
PPR	x	0	1	1	1	1	0	1
PPS	x	1	1	1	1	1	0	1
CTC	x	1	0	0	1	0	0	0
CTR	x	0	1	0	0	0	1	1
EOR	x	1	1	1	0	0	1	1
ERR	x	0	1	1	1	0	0	0
RTP	x	0	1	1	0	0	1	1
CRP	x	1	0	1	1	1	0	0

- X = 1 for the station which received DIS.
- X = 0 for the station which received a response signal to DIS.

4) Training

The training is performed in the binary procedure to surely transmit the image signals.

- Training signal

The training signal is transmitted following the DCS signal at the modem speed specified by the DCS signal. Responding to this training signal, the receiving side adjusts the auto-equalizer.

- Format of the training signal

14.4 Kbps, 12 Kbps

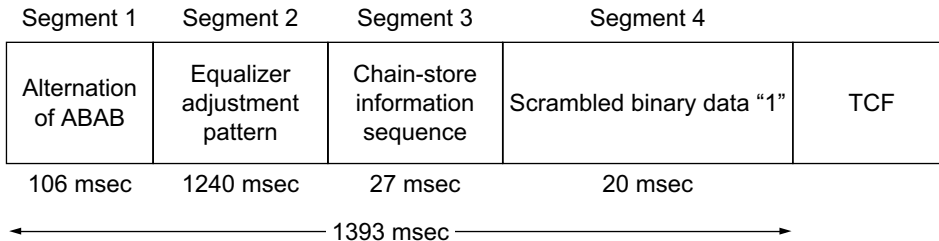

- 9600 bps, 7200 bps

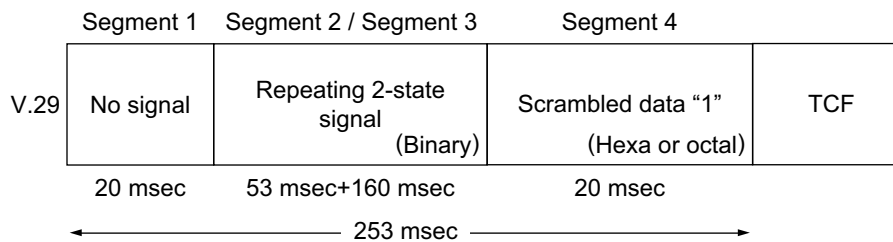

- 4800 bps, 2400 bps

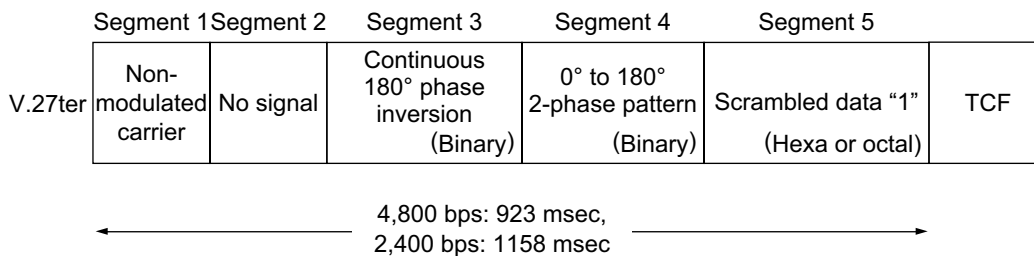

- TCF signal

An error may occur in the image data if the training is not performed correctly. The transmitting side sends a TCF signal and checks if any error occurs in image data before the image data communication to follow. When the receiving side detects an error in the TCF signal, it transmits an FTT signal to the transmitting side to request the retraining. When there is no error, the receiving side transmits a CFR signal.

The TCF signal transmits all zeros for 1.5 seconds at the same modem speed as that for the training signal.

3.2.3 V.8/V.34 communication sequence

1) Outline

- V.8 is performed as a startup procedure to switch to V.34. V.8 can connect an existing facsimile machine to the equipment using a data modem or other V-series modems. The V.34 modem has a modem circuit previously recommended, allowing it to be also connected to the existing modems while they are upper compatible.

 - New technologies such as the pre-emphasis technology *1 and the probing technology *2 are fully used. The pre-emphasis technology *1 not only speeds up the modulation, but also gains the S/N ratio. The probing technology examines the line characteristics and optimizes the modem for the line condition. Therefore, not only do these technologies speed up the transmission momentarily, but also the average speed of the process during the data transmission is increased.

 - For V.8 and the pre/post-FAX transmission for V.34, the procedure is speeded up by the full duplex communication.

 - Following 14 types of the image transmission speed are available: *3
33.6 kbps/31.2 kbps/28.8 kbps/26.4 kbps/24.0 kbps/21.6 kbps/19.2 kbps/16.8 kbps/14.4 kbps/
12.0 kbps/9.6 kbps/7.2 kbps/4.8 kbps/2.4 kbps

 - The modulating speed (baud rate) *4 can be selected from 2,400, 3,000, 3,200 symbol/sec (mandatory), or 2,743, 2,800, 3,429 symbol/sec (option). The data rate can be set more accurately than the conventional modem.
- *1 A signal is sent while raising the output level in the high-frequency band in which the noise is relatively loud.
- *2 Tone signal called "Probing Tone" is sent for the receiver to examine the line characteristics of the line.
- *3 In the ITU-T Recommendation, it is described as "data rate". "Image transmission speed" is the same as "data rate".
- *4 In the ITU-T Recommendation, it is described as "symbol speed". The "Symbol rate", "Modulating speed", and "Baud rate" are the same thing. This machine cannot realize the speed of 2,743 symbol/sec.

Notes:

1. ECM is used in the V.34 procedure. If the setting for the ECM transmission/reception of the user data is set to "Not performed", the V.8 procedure is not performed and the procedure is not switched to V.34. V.17 or lower is selected in this case.
2. When the transmission/reception speed is set to 14.4 kbps or slower, the V.8 procedure is not performed, and V.17 or lower is selected.
3. See "Late start (P3-20)" to move to the V. 8/V.34 procedure after starting with the V.21 procedure.
4. After the V.34 procedure is started, the fallback for the V.34 procedure is performed. However, the fallback for the V.17 mode or lower mode is not performed.

2) Standard procedure

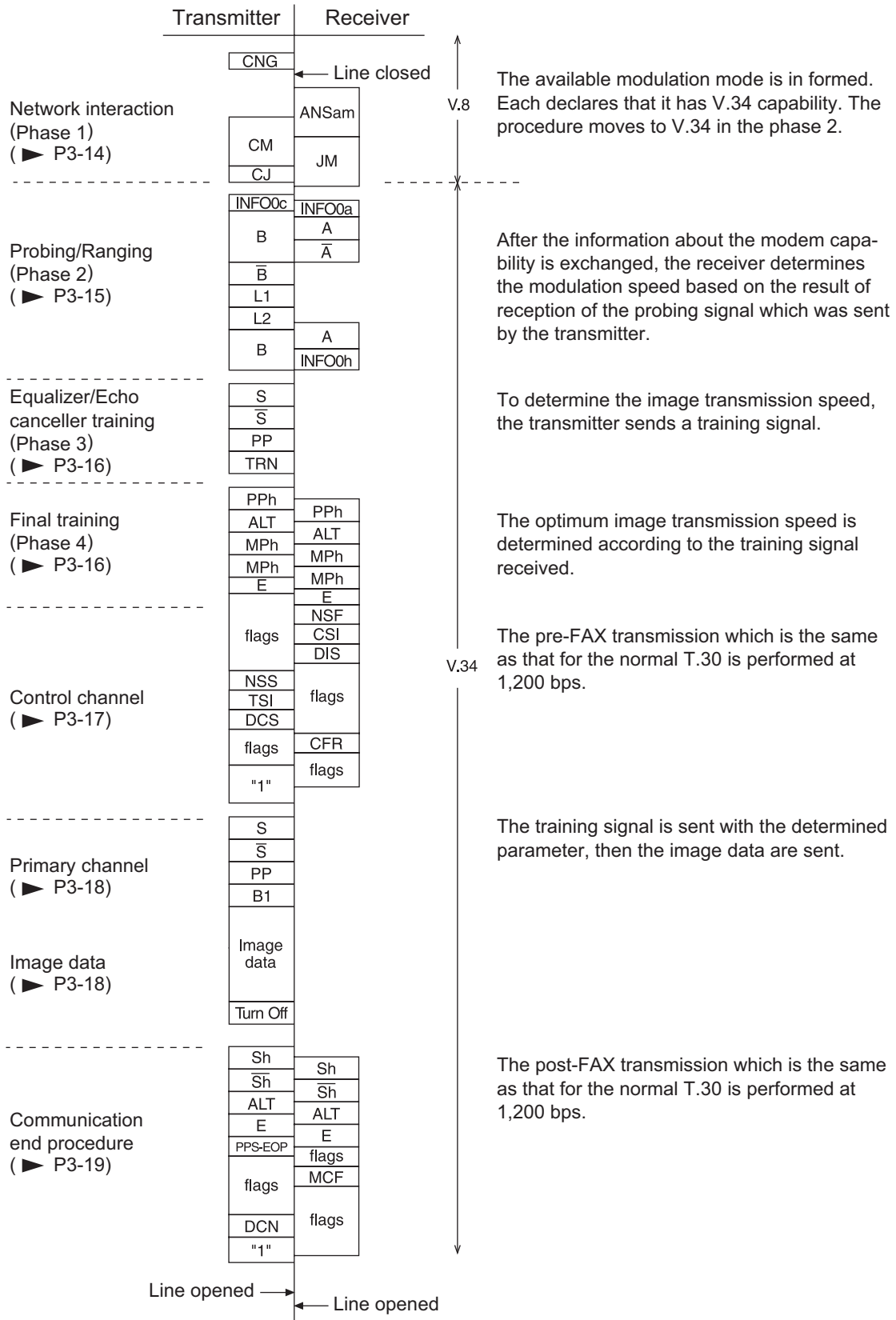

- Network interaction (Phase 1)

The V.8 procedure is performed as the startup procedure for the V.34 high-speed modem. In the V.8 procedure, mainly the optimum modulation method (V series modem mode) that can be operated between the transmitter and receiver is determined.

Transmitter

Signal name	Abbreviation	Function	Remarks
Calling tone	CNG	1100 Hz tone signal specified by T.30 indicating the sender is a FAX machine in the automatic calling mode.	-
Call Menu signal	CM	Mainly indicates an available modulation method such as V.21, V.27ter, V.29, V.17, V.34, etc.	Modulated by V.21 (L) *1. Transmission rate: 300 bps
CM terminator	CJ	Indicates the detection of the JM signal or the termination of CM signal.	Modulated by V.21 (L) *1. Transmission rate: 300 bps
Call Indicator signal	CI	Indicates the general communication functions. It is sent when the V.8 procedure is restarted.	For the late start only. (P3-20) Modulated by V.21 (L) *1. Transmission rate: 300 bps

Receiver

Signal name	Abbreviation	Function	Remarks
Answer amplitude tone	ANSam	2100 Hz tone signal amplitude-modulated to 15 Hz.	Tone equivalent to CED of the conventional machine.
Joint Menu signal	JM	Indicates the terminal type such as a FAX machine. Response to a CM sent from the transmitter and informs available modulation method.	Modulated by V.21 (H) *1. Transmission rate: 300 bps

- *1 V.21 (L)Low frequency channel defined by the V.21 recommendation 1,080±100 Hz
(980 Hz: 1, 1,180 Hz: 0)
V.21 (H)High frequency channel defined by the V.21 recommendation 1,750±100 Hz
(1,650 Hz: 1, 1,850 Hz: 0)

- Probing/Ranging (Phase 2)
Examines the line characteristics and sets the parameters for the modulation related items such as the modulating speed.

Transmitter

Signal name	Abbreviation	Function	Remarks
INFO sequence	INFO0c	Informs the modem capability such as modulating speed and frequency transmission capability (two frequency bands (high and low) used to examine the line characteristics), and requests for adjusting.	Transmission rate: 600 bps
Tone B	B	Synchronization between the modems by 1200 Hz tone signal	\bar{B} is a signal that shifts the phase B 180°.
Tone \bar{B}	\bar{B}		
Line probing signal L1	L1	Tone signal to analyze the line characteristics by probing	Probing is to examine the line characteristics. Tone signal between 150 Hz and 3,750 Hz in units of 150 Hz
Line probing signal L2	L2		

Receiver

Signal name	Abbreviation	Function	Remarks
INFO sequence	INFO0a	Informs the modem capability such as the modulating speed and frequency transmission capability.	Transmission rate: 600 bps
Tone A	A	Synchronization between the modems by 2,400 Hz tone signal	\bar{A} is a signal that shifts the phase A 180°.
Tone \bar{A}	\bar{A}		
INFO sequence	INFO0h	Based on the analysis of the line probing signal sent from the transmitter, it informs the pre-emphasis filter and modulating speed to be used for the data transmission.	Transmission rate: 600 bps

- Equalizer and echo canceller training (Phase 3)
Training (adjustment) is performed according to the parameters set in the phase 2 to optimize the filters such as an equalizer.

Transmitter

Signal name	Abbreviation	Function	Remarks
S signal	S	Short training	\bar{S} is a signal made as the result of phase transition of S.
\bar{S} signal	\bar{S}		
PP signal	PP	Used by the modem of the receiver to train the equalizer.	
TRN signal	TRN	Used by the receiver to determine the transmission rate.	

- Final training (Phase 4)
The settings such as the maximum value for the data rate, selection of the trellis encoder, and data rate which can be supported are made in this phase.

Transmitter/receiver

Signal name	Abbreviation	Function	Remarks
PPh signal	PPh	Used by the modem of the other side to train the equalizer.	
ALT signal	ALT	-	
Modulation parameter	MPh	Informs the parameters used for the image transmission such as maximum data signal rate and type of the trellis coding/pre-coding.	
E sequence	E	-	20 bit sequence of "1"s in binary

- Control channel
The conventional T.30 procedure is performed. The transmission rate is 1200 bps.

Transmitter

Signal name	Abbreviation	Function	Remarks
Flag	flags	Maintains the synchronization.	7E (H)
Non-standard facilities setting	NSS	Receives an NSF sent from the receiver. It selects the available mode from the received NSF, and specifies the mode for the reception.	
Transmitting Subscriber ID	TSI	Informs the telephone number of the transmitter.	
Digital Command Signal	DCS	Specifies the mode that can be used for the communication.	
-	1	Declares to switch to the high-speed procedure.	"1" is sent continuously.

Receiver

Signal name	Abbreviation	Function	Remarks
Non-Standard Facilities	NSF	Informs the presence of the facilities other than those recommended by ITU-T, abbreviated user names, and manufacturer codes, etc.	
Called Subscriber ID	CSI	Informs the telephone number of the receiver.	
Digital Identification Signal	DIS	Informs the standard facilities recommended by ITU-T.	
Flag	flags	Maintains the synchronization.	7E (H)
Confirmation for Reception	CFR	Informs that the training of the modem is completed, and the receiver is ready to receive the image signal.	

Reference: In the control channel, the frequency of the signals to be sent is different between the transmission and reception. The signal echoed back has never been misidentified as a signal sent from the other side. Therefore, this channel is not influenced by signals echoed back.

- Primary channel

The training is performed according to the parameters set in the phase 4. The transmission rate is 1,200 bps.

Transmitter

Signal name	Abbreviation	Function	Remarks
S signal	S	Short training	\bar{S} is a signal that makes a transition from phase S.
\bar{S} signal	\bar{S}		
PP signal	PP	Used by the modem of the receiver to train the equalizer.	
B1 sequence	B1	Scrambled data frame to be sent when the startup process is completed	

- Image data

Image data are sent.

Transmitter

Signal name	Abbreviation	Function	Remarks
Image data	Image data	Encoded image data	
-	Turn off	-	Scrambled 1 is sent for 35 ms.

- Communication end procedure
This procedure is to terminate the communication. The transmission rate is 1,200 bps.

Transmitter

Signal name	Abbreviation	Function	Remarks
Sh signal	Sh	Short training	
$\overline{\text{Sh}}$ signal	$\overline{\text{Sh}}$		
ALT signal	ALT	-	
E sequence	E	-	
End of procedure signal	PPS-EOP	The transmission of one page is completed.	
Flag	flags	Maintains the synchronization.	7E (H)
Disconnection signal	DCN	Informs to disconnect the line.	

Receiver

Signal name	Abbreviation	Function	Remarks
Sh signal	Sh	Short training	
$\overline{\text{Sh}}$ signal	$\overline{\text{Sh}}$		
ALT signal	ALT	-	
E sequence	E	-	
Flag	flags	Maintains the synchronization.	7E (H)
Message confirmation	MCF	Indicates that the image signal is received normally, and the receiver is ready to receive the next page.	

3) Example of protocol

The signals shaded in the following figure are the most important signals in the procedure.

- Late start

The receiver cannot detect CM signal while it is sending the ANSAm signal. Therefore, it sends a DIS signal to inform the availability of V.8 support. The transmitter sends a CI signal that causes the receiver to send another ANSAm signal which makes the receiver move to the V.8 procedure.

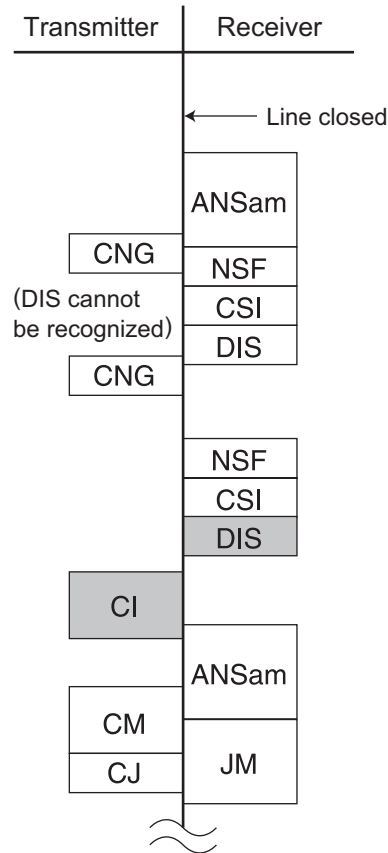

- Multi-page sequence

In the same manner as the T.30 procedure, the transmitter sends a PPS-MPS signal after sending the image data. The receiver sends an MCF signal and moves to the next page transmission.

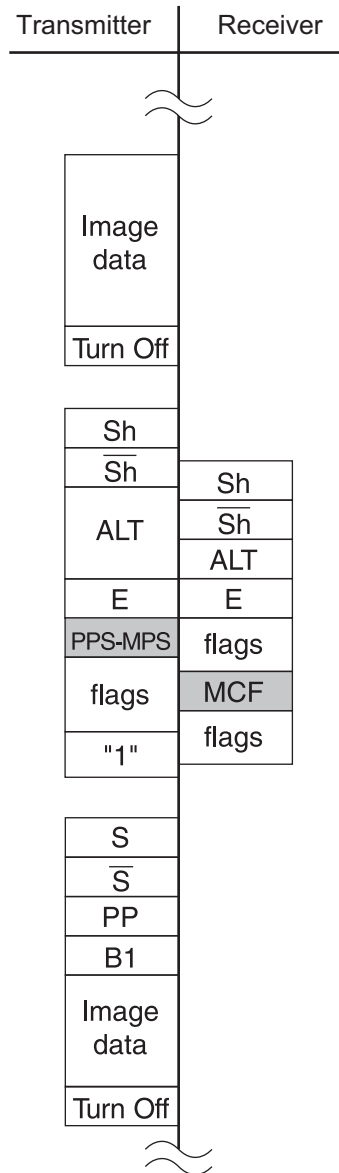

- Mode change

The transmitter and receiver send a PPS-EOM signal and an MCF signal respectively. Then the receiver and transmitter send a DIS signal and a DCS signal respectively to change the mode.

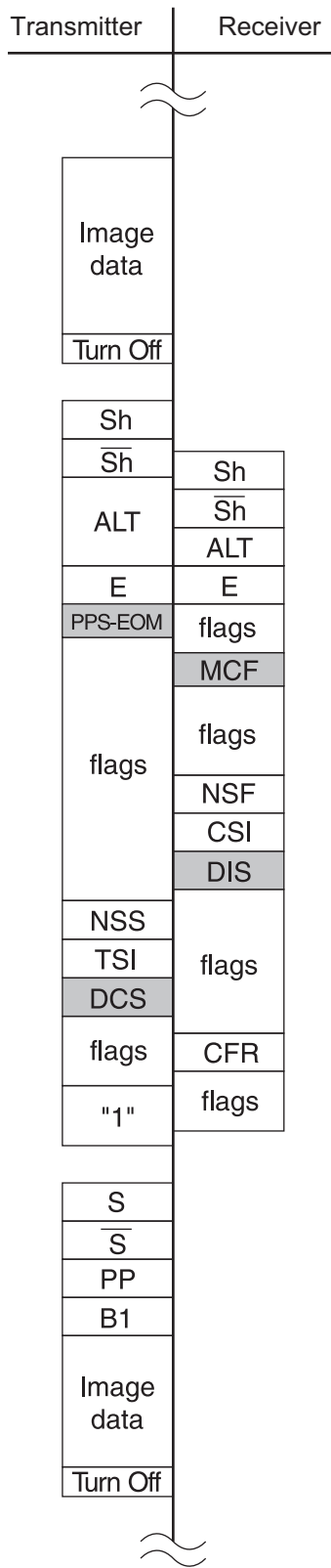

- Change of the image transmission speed by the receiver
The receiver sends a PPh signal responding to an Sh signal sent from the transmitter. Then, the image transmission speed is determined according to the MPh sequence sent from the both modems.

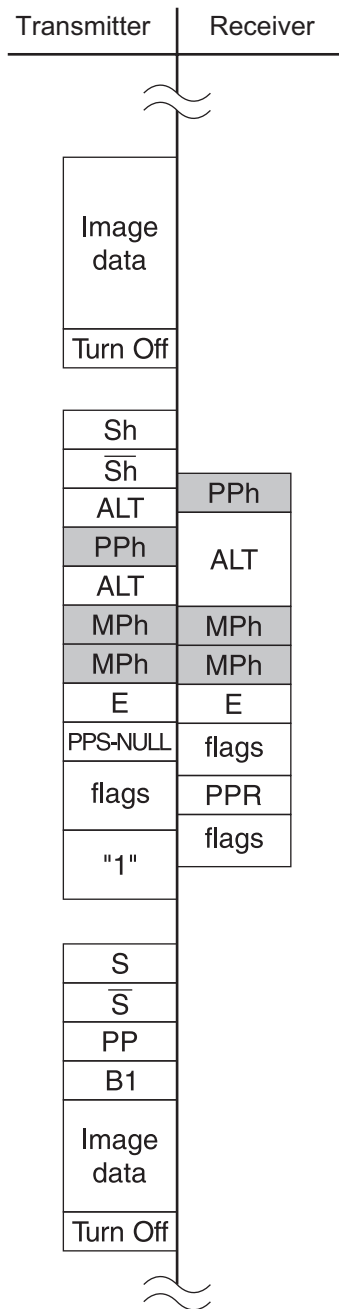

- Change of the image transmission speed by the transmitter
The transmitter sends a PPh signal after sending the image data. The receiver returns a PPh signal. Then, the image transmission speed is determined according to the MPh sequence sent from the both modems.

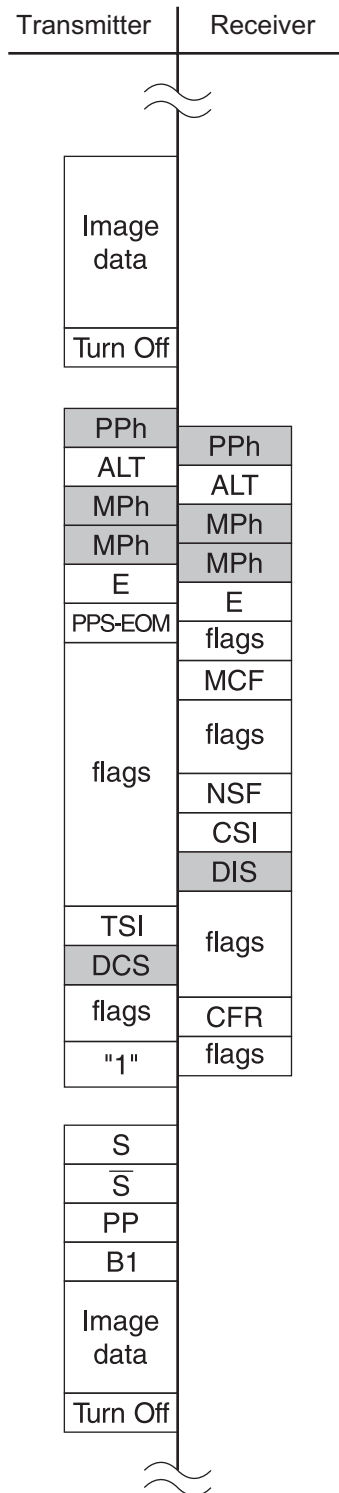

3.3 FAX Automatic Switching

3.3.1 General functions

There are two types of setting for the FAX Auto-Switching Mode Selection: TEL Mode and FAX Mode.

3.3.2 TEL mode

This mode is selected to prioritize telephone communication when the frequency of the fax reception is low. When the TEL mode is selected, the automatic FAX reception function does not work. Therefore, when a calling signal comes from the exchange, the telephone ringer continues ringing until the operator picks up the handset. When the operator has learned that the caller is sending a FAX, he has to perform the manual reception operation.

3.3.3 FAX mode

This mode is selected when the telephone circuit is used only for FAX communication. When the FAX mode is selected and a calling signal comes from the exchange, the FAX reception operation starts automatically without ringing the telephone ringer.

In the FAX mode, a calling number can be set up to 15 calls in the SET FUNCTION (FUNC 14 Bits 7 to 4).

<Method of judging CNG detection>

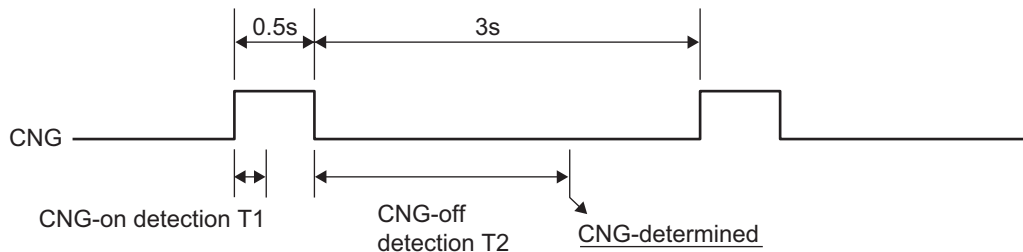

- As shown above, after CNG-on detection time T1 (175 ms) and CNG-off detection time T2 (350 ms) have elapsed, and the T1 period has been turned on and then the T2 period off, CNG is determined to have occurred once.

4. ELECTRICAL CIRCUITS

4.1 Configuration

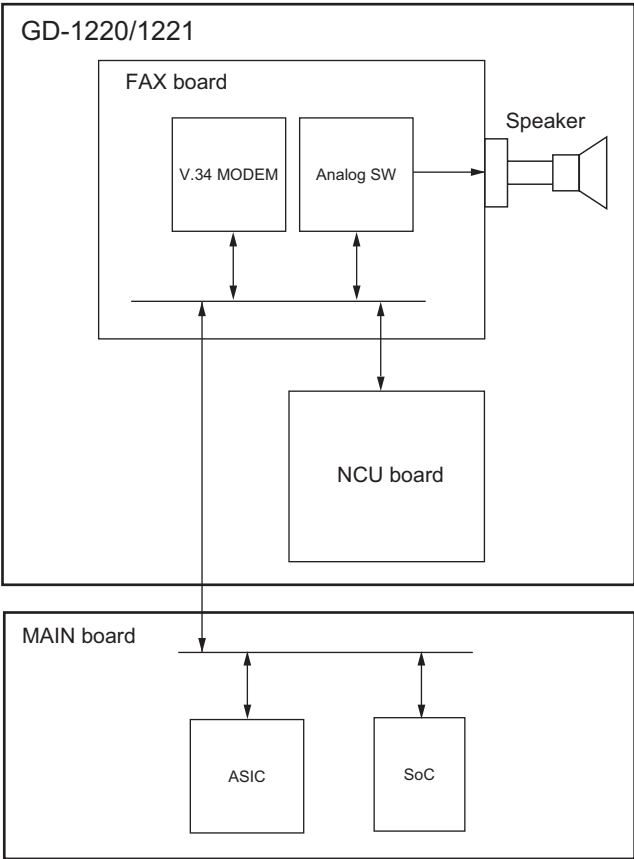

Fig. 4-1

4

4.2 Description of Circuits

4.2.1 Configuration

This section describes the function of each circuit.

The NCU board consists of the transformer, relay, analog switch and other peripheral devices. It controls switching of the line path, generates the dial pulses, detects the line current and ring signal, and monitors the line.

NA/TW models

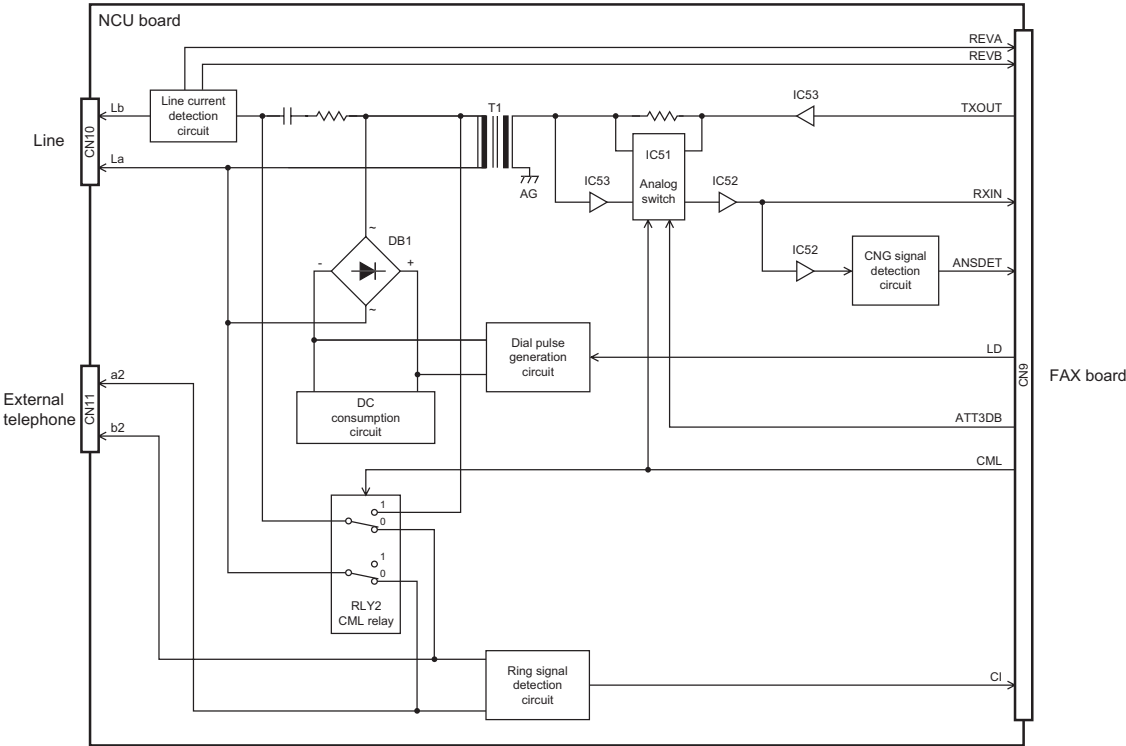

Fig. 4-2

EU/AU/AS/C models

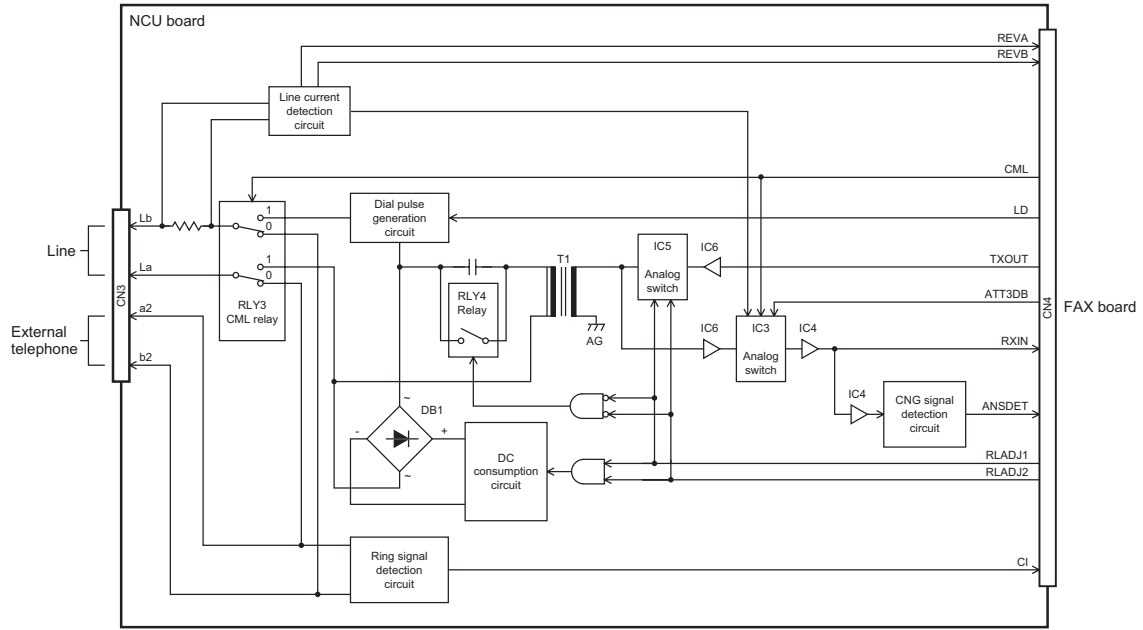

Fig. 4-3

4.2.2 Line path switching control circuit

NA/TW models

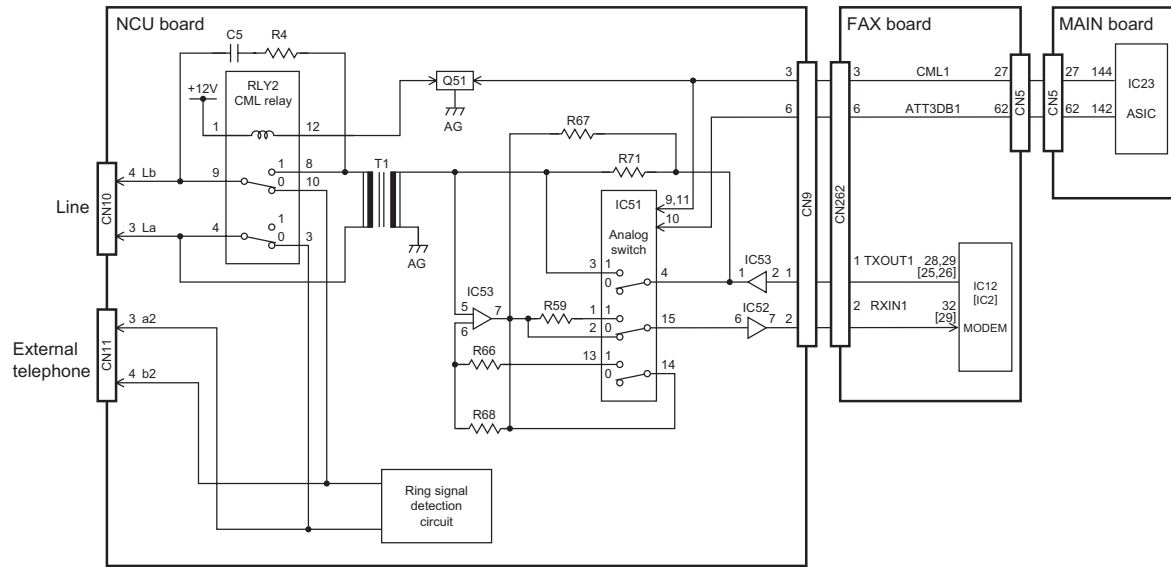

Fig. 4-4

The line path switching control circuit consists of the CML relay (RLY2) and analog switch (IC51) on the NCU board, the ASIC (IC23) on the MAIN board and the other peripheral devices.

The CML relay is switched according to the CML1 signal output from the ASIC on the MAIN board. When the CML1 signal goes HIGH, Q51 comes on to turn ON the CML relay.

The analog switch is switched according to the CML1 signal and ATT3DB1 signal. When the CML1 signal or ATT3DB1 signal goes HIGH, the analog switch is turned ON.

Turning ON the CML relay and analog switch allow the MODEM to be connected to the line.

Signal Name	Type	Active	Description	Destination
CML1	O	H	Line 1 CML Relay Control Signal	RLY2, IC51
ATT3DB1	O	H	Line 1 Attenuator Control Signal	IC51

* Values in [] are GD-1221 in case that the descriptions vary between GD-1220 and GD-1221.

EU/AU/AS/C models

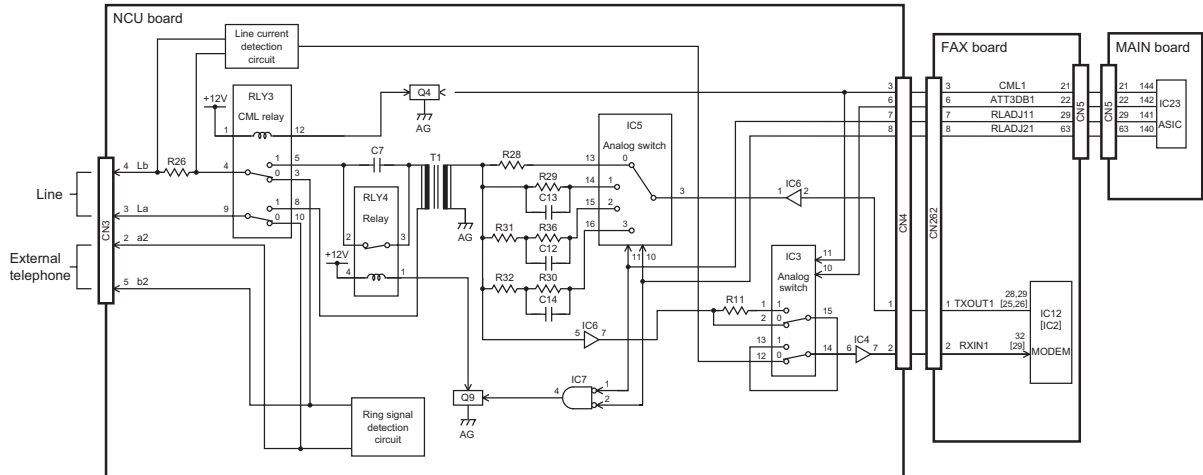

Fig. 4-5

The line path switching control circuit consists of the CML relay (RLY3) and analog switch (IC3, IC5) on the NCU board, the ASIC (IC23) on the MAIN board, and the other peripheral devices. It changes the path for the FAX send/receive signals and connects it to each control circuit.

The CML relay is switched according to the CML1 signal output from the ASIC on the MAIN board. When the CML1 signal goes HIGH, Q4 comes on to turn ON the CML relay.

The analog switch (IC3) is switched according to the CML1 signal and ATT3DB1 signal. When the CML1 signal or ATT3DB1 signal goes HIGH, the analog switch is turned ON.

The analog switch (IC5) is switched according to the RLADJ11 and RLADJ12 signals. The analog switch is switched according to the states of the RLADJ11 and RLADJ21 signals. Turning ON the CML relay and analog switch allow the MODEM to be connected to the line.

Signal Name	Type	Active	Description	Destination
CML1	O	H	Line 1 CML Relay Control Signal	RLY3, IC3
ATT3DB1	O	H	Line 1 Attenuator Control Signal	IC3
RLADJ11, 21	O	H	Line 1 Return Loss Adjustment Signal	IC5

* Values in [] are GD-1221 in case that the descriptions vary between GD-1220 and GD-1221.

4.2.3 Dial pulse generation circuit

NA/TW models

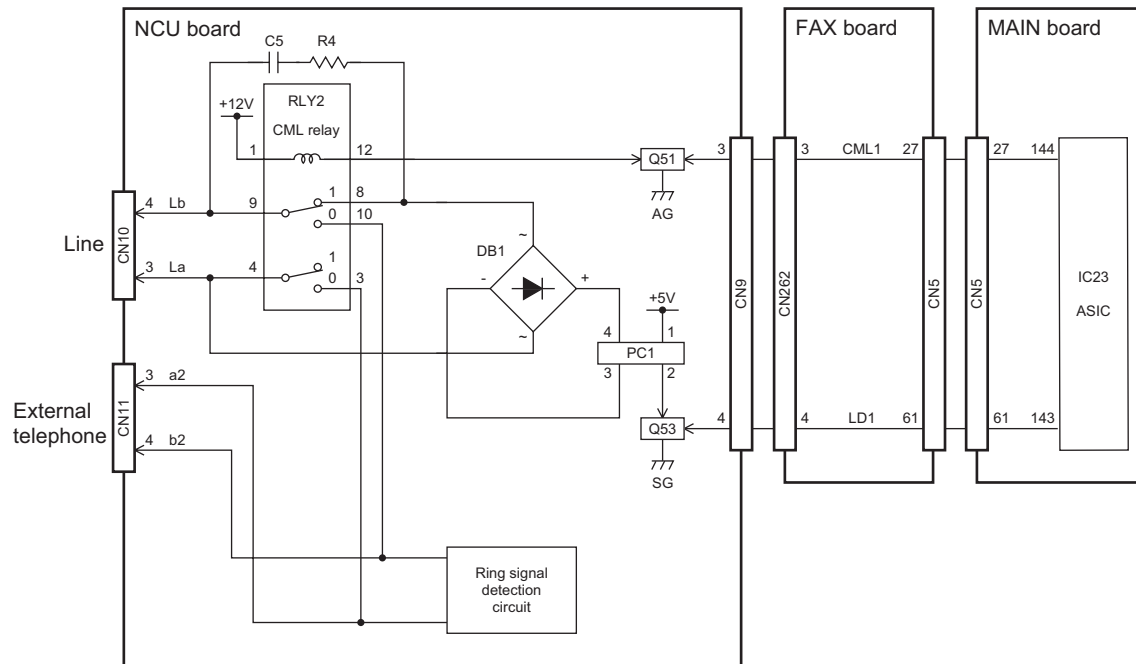

Fig. 4-6

The dial pulse generation circuit consists of the diode bridge (DB1), photocoupler (PC1), the ASIC (IC23) on the MAIN board and the other peripheral devices. It generates the dial pulses in the FAX transmission and dialing to the outside.

The ASIC makes the CML1 signal become HIGH to connect the line to the MODEM side. To generate the dial pulse, the ASIC makes the LD1 signal become HIGH to turn ON Q53. This allows the photocoupler to come on and the current flows through the DB1 to send the dial pulses to the line.

Signal Name	Type	Active	Description	Destination
LD1	O	H	Line 1 Dial Pulse Generation Signal	Q53

4.2.4 Line current detection circuit

NA/TW models

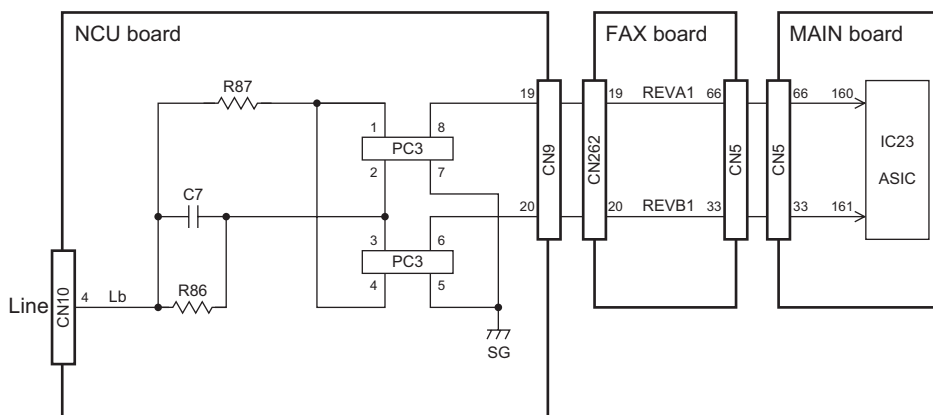

Fig. 4-8

The line current detection circuit consists of the photocoupler (PC3), ASIC (IC23) on the MAIN board and the other peripheral devices. It detects a dial tone and the hook status of the external telephone from the current flowing through the line.

When a dial tone is input from the telephone line, current flows through the line and the photocoupler is repeatedly turned ON/OFF. This allows the REVA1 and REVB1 to be the pulse signals and input to the ASIC, then the dial tone is detected.

When the handset is lifted from the external telephone, current also flows through the line and the photocoupler is turned ON/OFF, then the off-hook state is detected.

Signal Name	Type	Active	Description	Destination
REVA1	I	-	Line 1 Current Detection Signal	IC23
REVB1	I	-	Line 1 Reverse Current Detection Signal	IC23

EU/AU/AS/C models

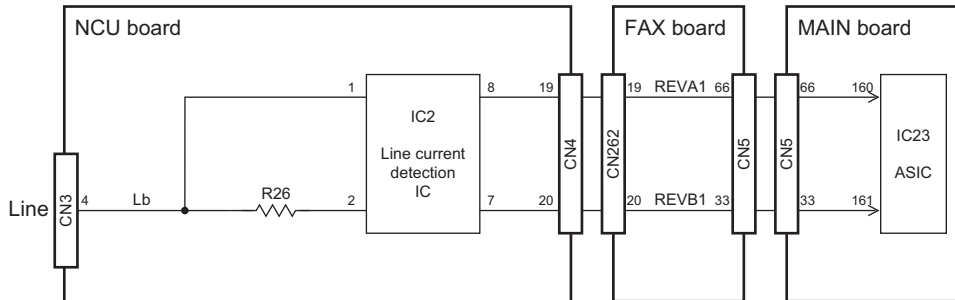

Fig. 4-9

The line current detection circuit consists of the line current detection IC (IC2), ASIC (IC23) on the MAIN board, and the other peripheral devices. It detects a dial tone and the hook status of the external telephone from the current flowing through the line.

When a dial tone is input from the telephone line, current flows through the line. The line current detection IC sends REVA1 and REVB1 to the ASIC as pulse signals. This allows a dial tone to be detected.

Signal Name	Type	Active	Description	Destination
REVA1	I	-	Line 1 Current Detection Signal	IC23
REVB1	I	-	Current Reverse Line 1 Current Detection Signal	IC23

4.2.5 CI detection circuit

NA/TW models

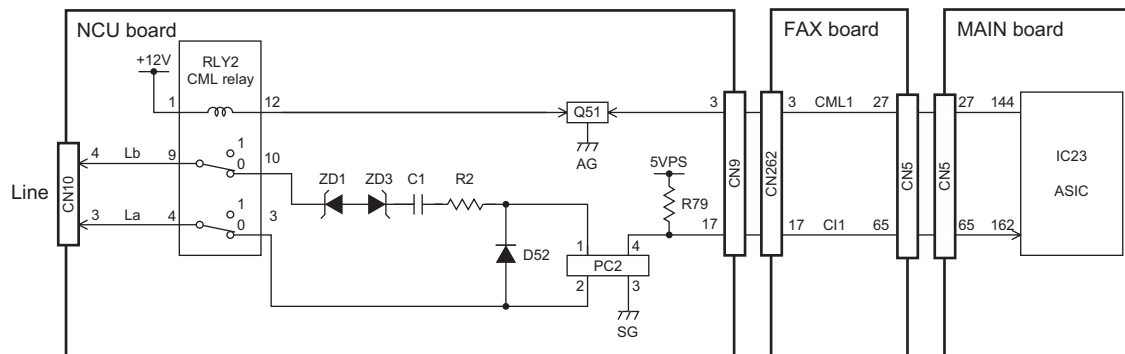

Fig. 4-10

The CI detection circuit consists of the photocopier (PC2), ASIC (IC23) on the MAIN board and the other peripheral devices to detect a ring signal input from the telephone line.

The ASIC makes the CML1 signal become LOW to connect the CI detection circuit to the telephone line.

When a ring signal is input from the telephone line, the photocopier is repeatedly turned ON/OFF. This allows the C11 signal to become a pulse signal and input to the ASIC on the MAIN board, thereby detecting the ring signal.

Signal Name	Type	Active	Description	Destination
C11	I	-	Line 1 CI Detect Signal	IC23

4.2.6 Line monitor circuit

NA/TW models

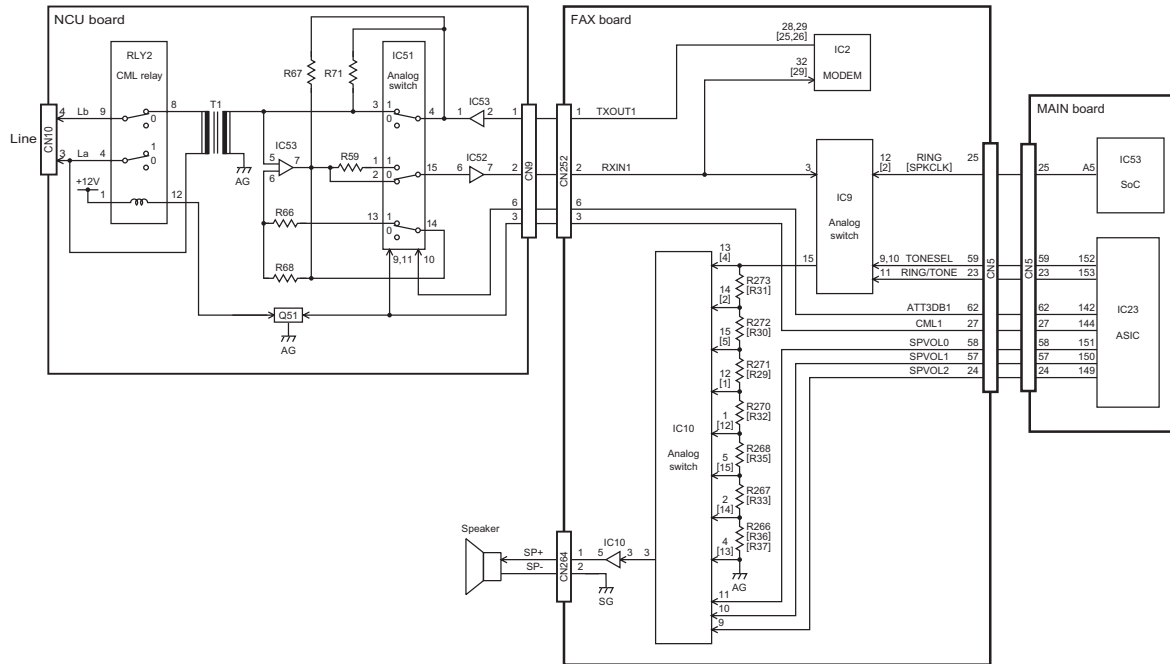

Fig. 4-12

EU/AU/AS/C models

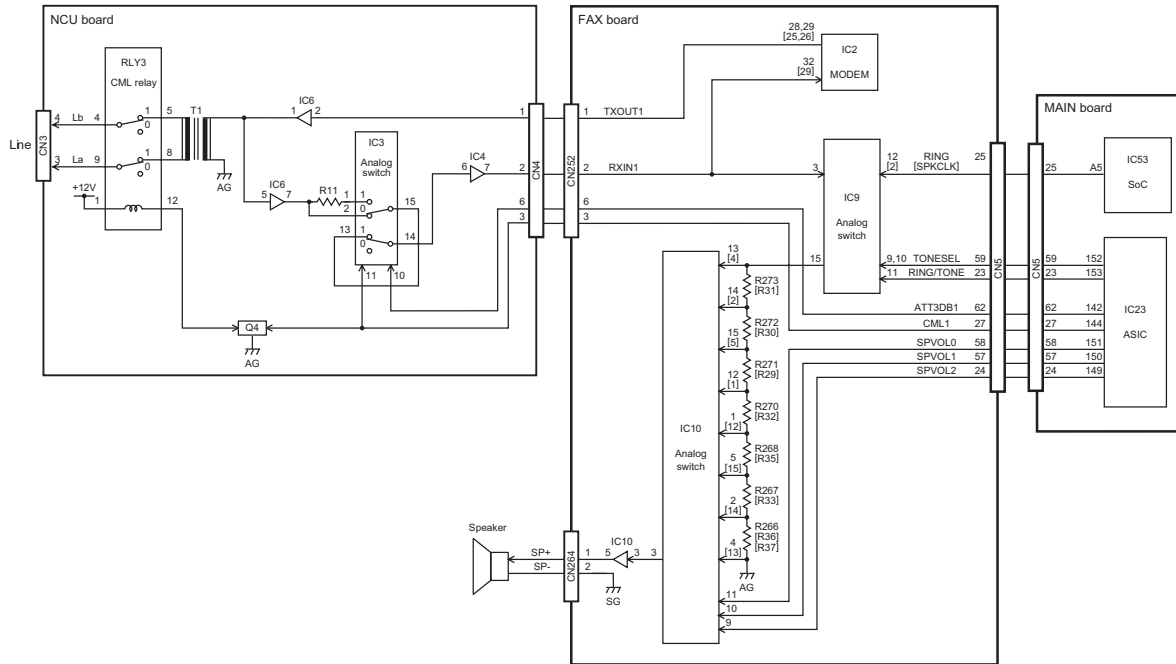

Fig. 4-13

The line monitor circuit consists of the CML relay (NA/TW: RLY2, EU/AU/AS/C: RLY3), analog switch (NA/TW: IC51, EU/AU/AS/C: IC3), analog switches (IC9, IC10) on the FAX board, ASIC (IC23) and SoC (IC53) on the MAIN board, and other peripheral devices. It switches the telephone line path using the analog switch and monitors the line status and ringer signal in the FAX transmission and reception using the speaker connected to CN503 on the FAX board. It also switches the analog switch to output a buzzer tone from the speaker.

The signal to be monitored is selected by switching the analog switch (IC9) according to TONESEL signal and RING/TONE signal which are output from the ASIC.

To monitor the line during the transmission and reception, the ASIC makes the CML1 signal become HIGH to switch the analog switch and connect the line to the MODEM side.

For the line path switching control, refer to [P. 4-4 "4.2.2 Line path switching control"](#).

The relation between the signal levels and monitoring signals is as follows.

Monitoring signal	TONESEL	RING/TONE
LINE Monitor	LOW	HIGH
Ringer/Alarm	-	LOW

The monitoring signal selected by IC9 is input to the analog switch (IC10) to select the output sound volume. The sound volume is selected by switching IC10 according to the SPVOL0-2 signals output from the ASIC and selecting an input resistance for the monitoring signal.

The relation between the signals and sound volume is as follows.

Sound volume	SPVOL2	SPVOL1	SPVOL0
Max. (7)	LOW	LOW	LOW
(6)	LOW	LOW	HIGH
(5)	LOW	HIGH	LOW
(4)	LOW	HIGH	HIGH
(3)	HIGH	LOW	LOW
(2)	HIGH	LOW	HIGH
Min. (1)	HIGH	HIGH	LOW
Silent (0)	HIGH	HIGH	HIGH

The monitoring signal whose volume is controlled by IC10 is amplified by the OP amplifier (IC17), then output to the speaker.

Signal Name	Type	Active	Description	Destination
TONESEL	O	H	Line/Tone Selection Signal	IC9
RING/TONE	O	H	Ring/Tone Selection Signal	IC9
SPVOL0-2	O	H	Speaker Volume Control Signals 0-2	IC10

* Values in [] are GD-1221 in case that the descriptions vary between GD-1220 and GD-1221.

4.3 PC Boards

1) PWA-F-FAX-635 (GD-1220)

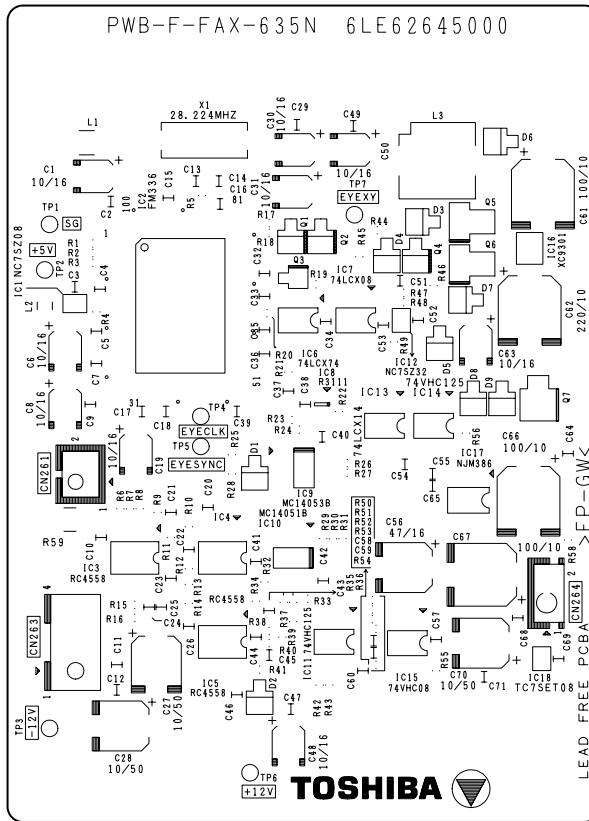

Fig. 4-14

4

2) PWA-F-FAX-678 (GD-1221)

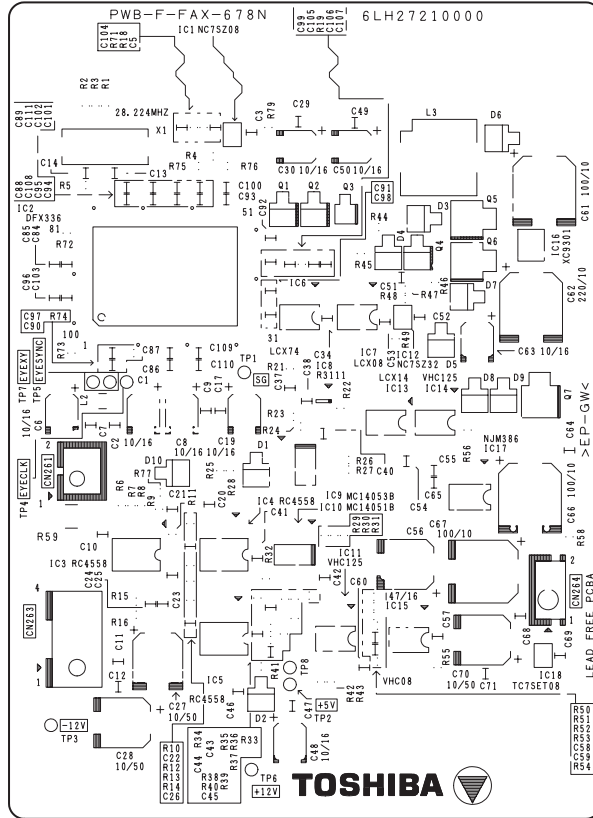

Fig. 4-15

3) PWA-F-NCU-631 (NAD, TWD, SAD)

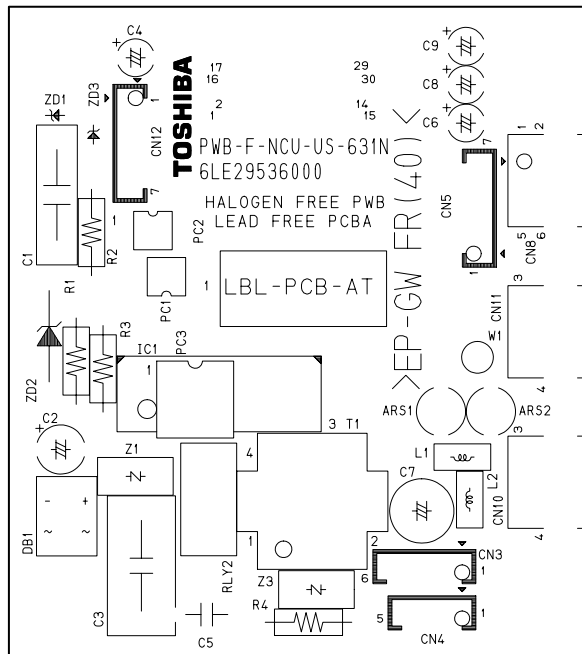

Fig. 4-16

4) PWA-F-NCU-631 (MJD, AUD, ASD, CND)

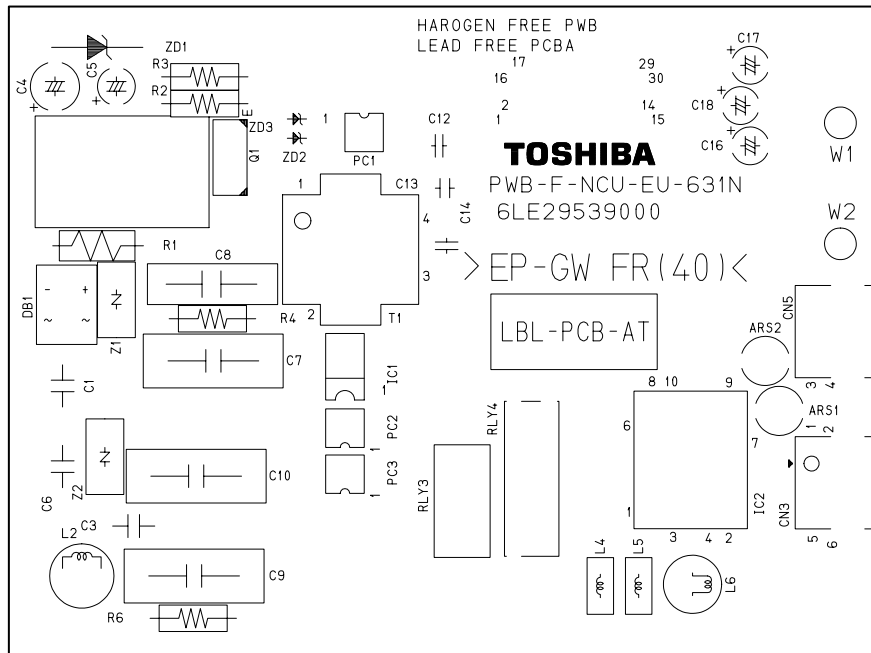

Fig. 4-17

5. INSTALLATION

5.1 Explanation to the Users

After installing the FAX unit, explain the following items to the user using the Operator's Manual. With the underlined items, actually demonstrate the operation.

Items to be explained

- Switches and control panel
 - Summary of the control panel (FAX functions)
 - After power is turned OFF, image data are kept in HDD.

- How to set originals
 - Acceptable original size and scanning width
 - How to insert originals:
Multiple originals placed on the RADF are scanned from the first page.
 - Unacceptable originals
 - How to set the mode (image quality) and density (contrast)

- Transmission method
 - Manual transmission
 - Monitor dialing
 - Direct dialing (with the digital keys)
 - Phone book dialing
 - Delayed transmission
 - Multi transmission
 - Redialing

- Recording paper size
 - Recording paper size
 - How to change the recording paper size

- Automatic/manual reception
 - How to switch the automatic and manual reception
 - How the machine works and how to operate it when a FAX is received in these modes

- Other functions
 - Memory reception (with the power kept ON)
 - How to set the power saving mode

- Polling
 - Polling operation
 - How to operate the polling reception and transmission
 - How the multi-polling reception works and how to operate it

- How to register addresses
 - How to register new addresses in the Phone Book
 - How to correct or erase the contents of the Phone Book
 - Group registration in the phone book for the multi-transmission or multi-polling

- How to output lists
 - How to output the TRANSMISSION JOURNAL and RECEPTION JOURNAL

TOSHIBA

TOSHIBA TEC CORPORATION

2-17-2, HIGASHIGOTANDA, SHINAGAWA-KU, TOKYO, 141-8664, JAPAN