

Facsimile

## Quick Reference Guide



KX-L5CL

Model No. **KX-L5CL**  
**KX-L5CW**

KX-L5CL has one portable handset.  
 KX-L5CW has two portable handsets.

Thank you for purchasing a Panasonic facsimile.

### Table of Contents

Finding the controls .....	2
Installations and connections .....	4
Setting the date and time .....	7
Setting your facsimile telephone number .....	7
Setting your logo .....	8
Character input and command key table .....	9
Automatic dialing on the main unit.....	10
Automatic dialing on the portable handset .....	12
Intercom between the main unit and portable handset .....	13
Intercom between portable handsets .....	14
Sending faxes .....	15
Receiving faxes .....	16
Operating the built-in answering device .....	20
L-mode service .....	21
Specifications.....	Back cover

- This guide explains some basic features and operations, but not all of them. For further details, see the Japanese operating instructions.
- This product is designed for use in Japan.  
Panasonic cannot provide service for this product if used outside Japan.
- Any details given in this guide are subject to change without notice.

# Finding the controls

## Main unit (control panel)

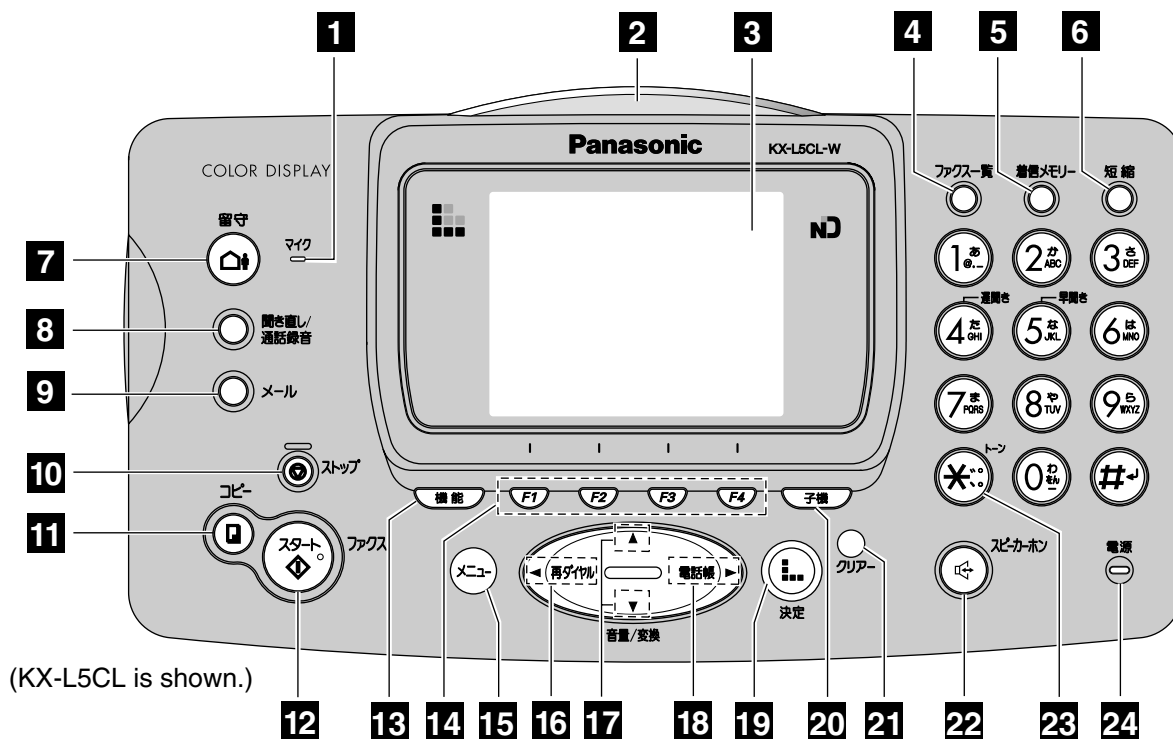

- 1 Microphone**
- 2 Call indicator**
- 3 Liquid crystal display**
- 4 Memory button & indicator** shows the list of received fax data.
- 5 Call memory button & indicator** starts a search in the Number Display log. (For caller ID display service users.)
- 6 Speed Dial button**
- 7 Auto Answer button**  
—light on: answering device activated.  
—light off: used as a regular telephone.
- 8 Replay button** plays back recorded messages. / **Record** button records telephone calls.
- 9 Mail button & indicator**
- 10 Stop button**
- 11 Copy button** starts copying.
- 12 Start/Fax button** starts faxing.
- 13 Function button** initiates programming.
- 14 Multi-operation buttons** refer to the function displayed on the display panel.
- 15 Menu button**
- 16 Redial button**
- 17 Search button** searches the directory by pressing the up and down buttons. **Volume** button adjusts ringer, speaker and handset volume by pressing the up and down buttons.
- 18 Phonebook button** uses the phonebook.
- 19 L-mode button**
- 20 Intercom button**
- 21 Clear button**
- 22 Speakerphone button**
- 23 Tone button** switches to tone dialing.
- 24 Power indicator**

# Finding the controls

## Portable handset

### How to use key



電話帳 To use the phonebook.



再ダイヤル To redial the last number dialed.



音量/変換 To adjust the volume.  
To change Hiragana into Kanji.

外線 To make/answer calls.

クリア  
内線 To page the main unit or another portable handset.  
To clear letters/numbers.

切 To end a call.  
To end or exit from editing or other operations.

着信メモリー  
保留 To put a call on hold.  
To start a search in the Number Display log.  
(For caller ID display service users.)

トク To talk to another portable handset.

キャッチ For call waiting service users.

ファクス  
めざまし To receive faxes.

スピーカーホン To use the speakerphone.

増設 Used when installing additional portable handsets.

Speaker

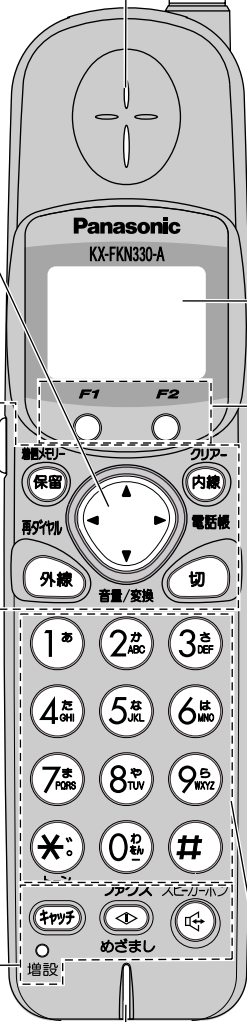

Microphone

(Do not cover the microphone while talking.)

### Call/Charge indicator

When receiving a call, the indicator will blink.

When placed on a charger  
Charging ..... On  
Full ..... Off

### LCD (with back light)

Displays battery strength, telephone numbers etc.

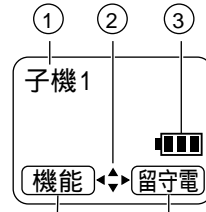

① ..... Portable handset number



② ..... Indicates which directions the

再ダイヤル  電話帳 key can be tilted.  
音量/変換



 up and down

 left

③ ..... Battery strength

④ ..... Function menu that is controlled by  or .

### How to use buttons

 and  buttons refer to the function displayed on the bottom of the display. They function differently depending on the mode.

### Dial buttons

 Tone button  
To switch to Tone dialing mode.

 Sharp button

# Installations and connections

## Installing the ink film

- 1 Open the control panel.

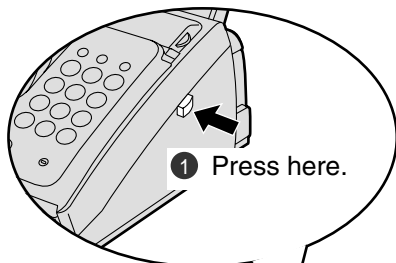

- 2 Open the control panel until it locks.

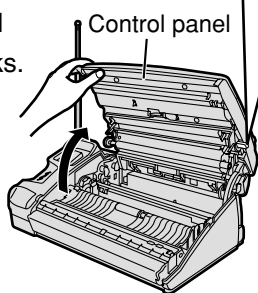

- 2 Insert the ink film.

- 1 Find the "T" shaped gear (blue).

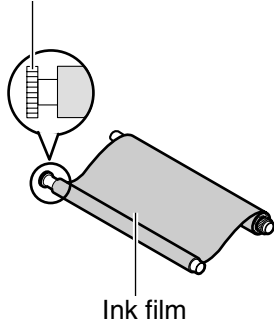

- 2 Insert the blue core into the right slot of the main unit.
- 3 Insert the "T" shaped gear (blue) into the left slot of the main unit.

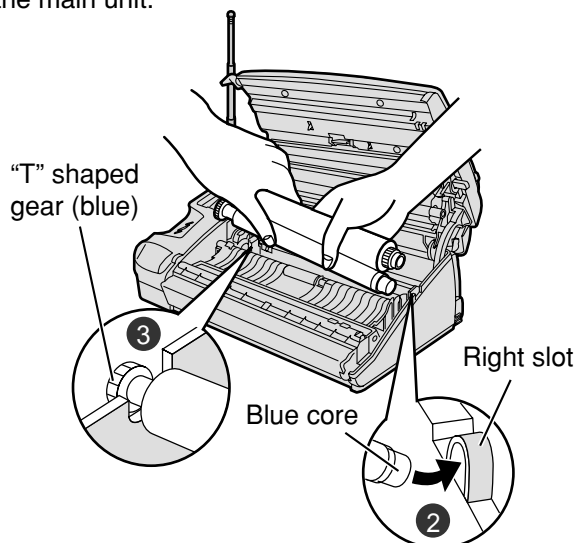

- 4 Insert the white core into the slots shown in the picture below.

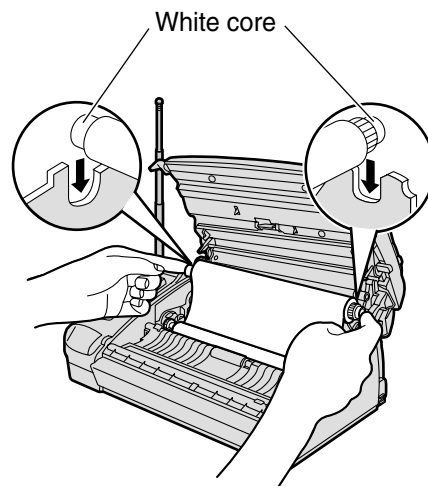

- 5 If the ink film is slack, tighten it by winding the "T" shaped gear.

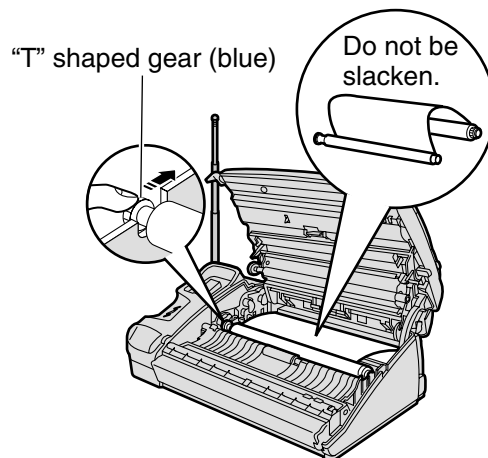

- 3 Close the control panel until it locks.

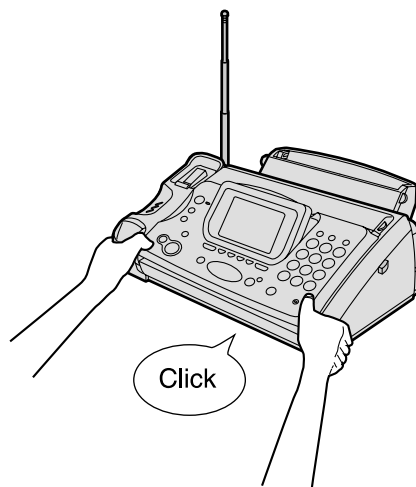

# Installations and connections

## Installing recording paper (A4 size)

**1** Install the recording paper tray.

- 1 Remove the recording paper cover.
- 2 Insert the left tab on the recording paper tray into the left slot of the main unit.
- 3 Insert the right tab into the right slot of the main unit.

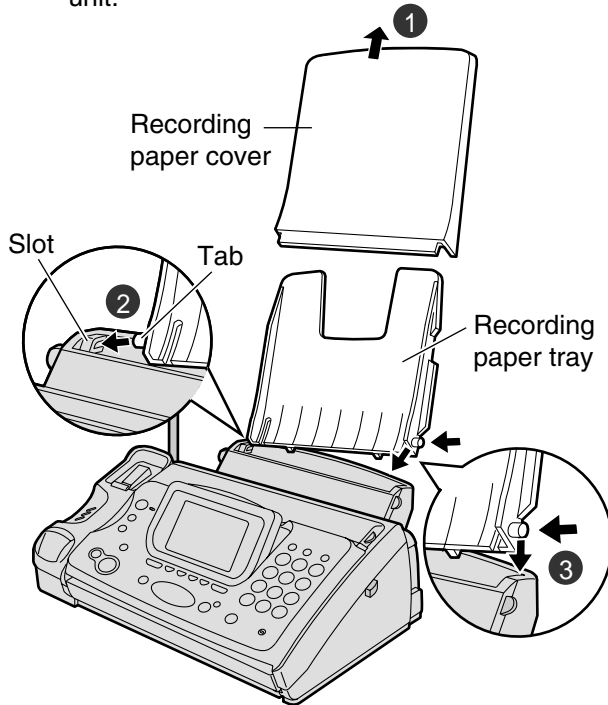

**2** Insert the recording paper into the recording paper tray.

- 1 Open the paper entrance cover until it locks.

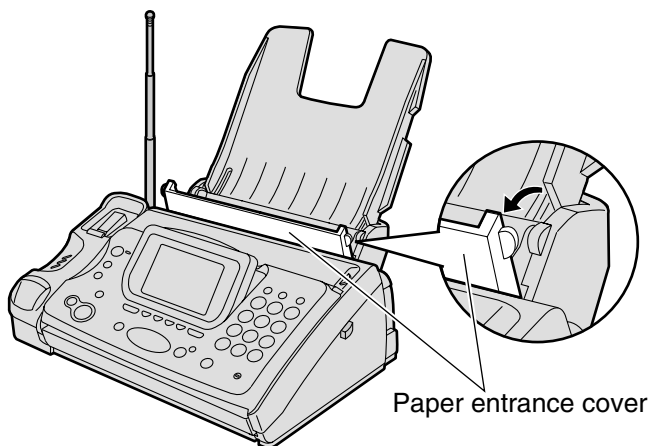

**2** Fan the stack of recording paper (A4 size).

**3** Insert the recording paper into the recording paper tray. (Up to 30 sheets)

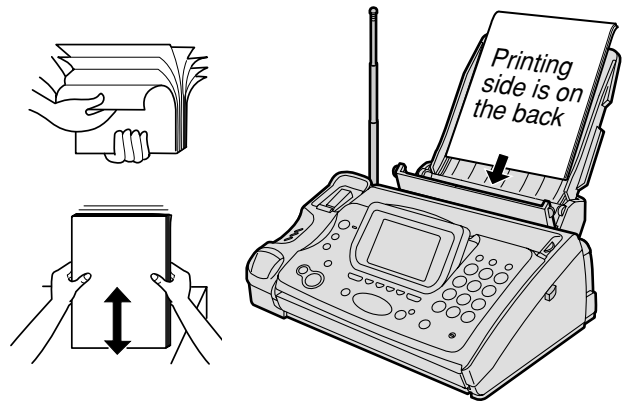

**3** Close the paper entrance cover by leaning it back.

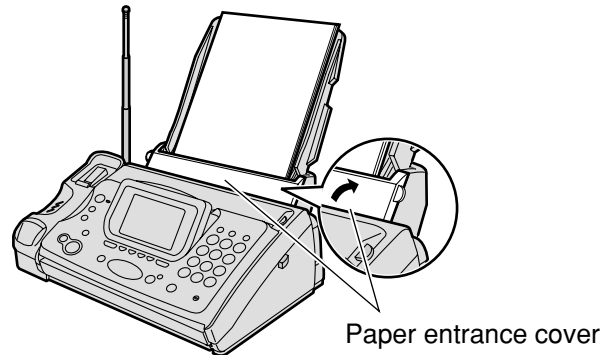

**4** Install the recording paper cover on the recording paper tray by sliding it down from the top.

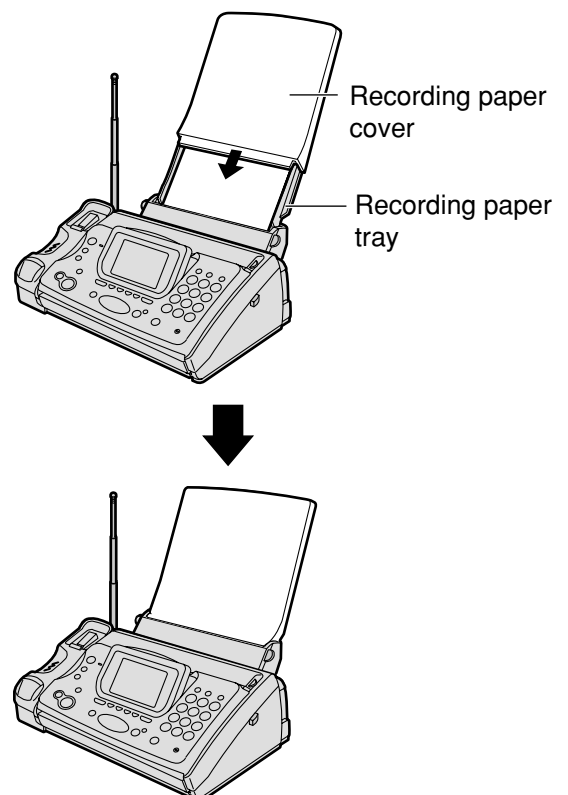

# Installations and connections

## Setting up the portable handset

1

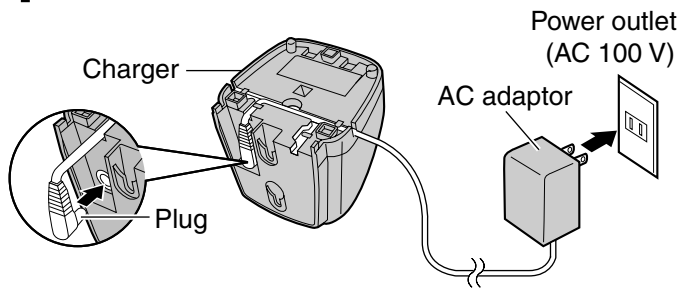

2

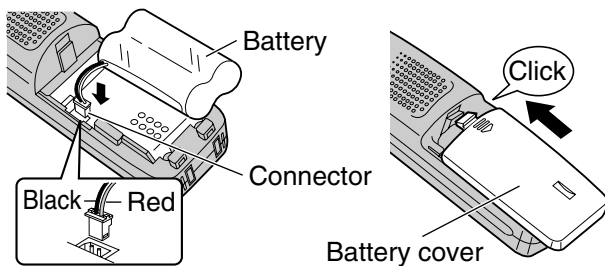

3 Charge the battery in the charger for 10 hours.

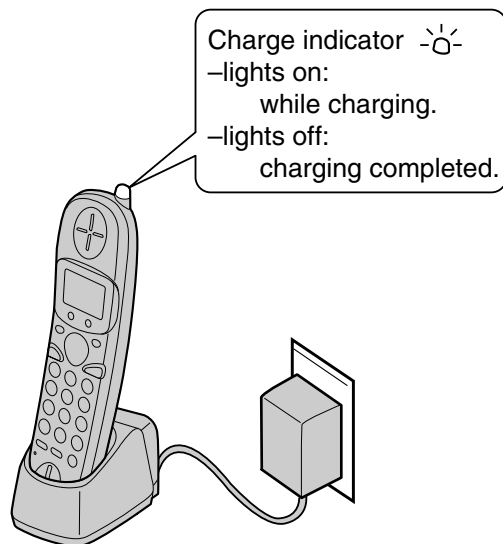

- After your Panasonic battery is fully charged, it will last up to about 7 hours of conversation.

## Connecting the main unit

1

Raise the antenna.

2

Connect the cord and place the handset on the main unit.

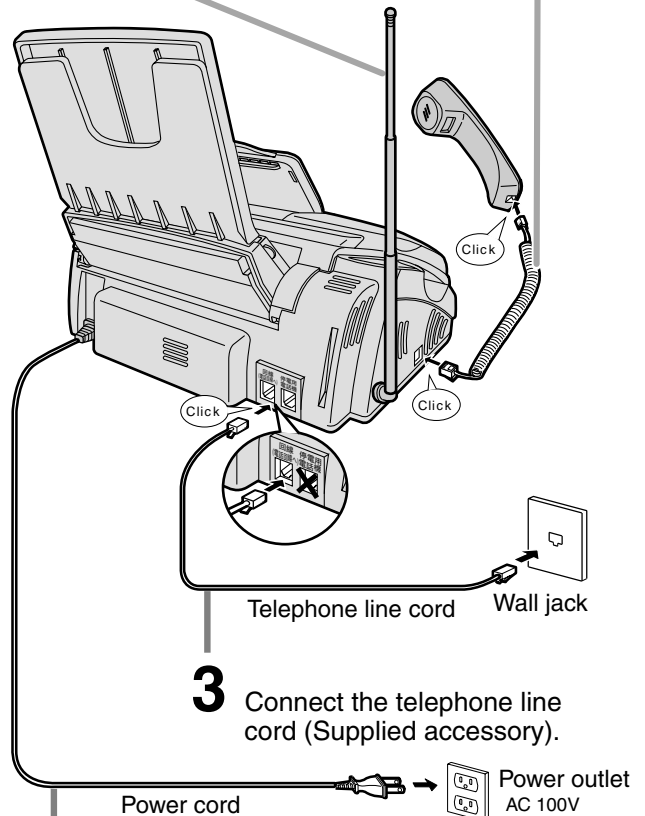

3

Connect the telephone line cord (Supplied accessory).

4

Connect the power cord.

### After the Power On...

This unit will automatically select the dialing mode (Tone/Pulse).

# Setting the date and time

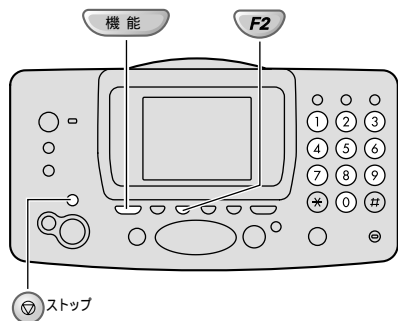

**1** Press **機能** (Function) and **1 1**.

**2** Enter the correct year/month/day.

**Example: October 1, 2002**

Press **2 0 0 2 1 0 0 1**.



**3** Enter the correct hour/minute in a 24-hour clock entry.

**Example: 15:45 (3:45 PM)**

Press **1 5 4 5**.

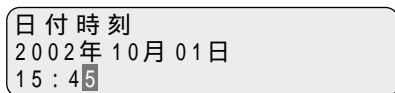

**4** Press **登録** (Register).

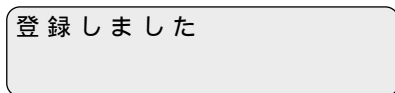

**5** Press **ストップ** (Stop).

# Setting your facsimile telephone number

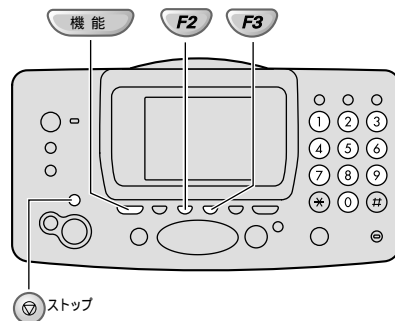

**1** Press **機能** (Function) and **1 4**.

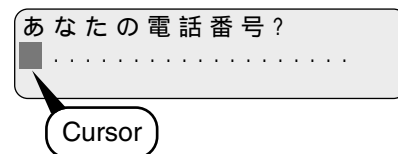

**2** Enter your facsimile telephone number, up to 20 digits.

**Example: 098 765 43..**

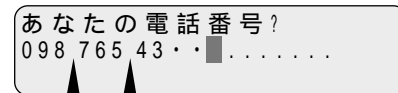

The **スペース** (Space) button replaces the digit with a space.

**3** Press **登録** (Register).

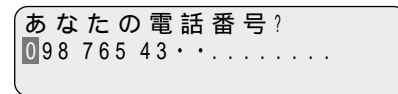
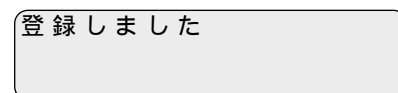

**4** Press **ストップ** (Stop).

# Setting your logo

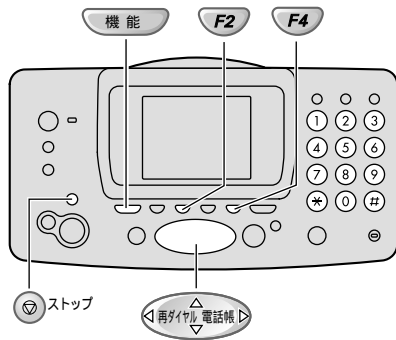

**1** Press **機能** (Function) and **1** **2** .

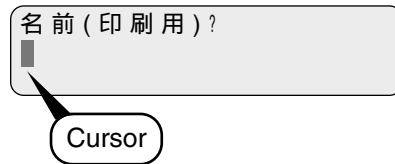

**2** Enter your logo, up to 30 characters, using the dial keypad.

- To enter English characters easily, press **F4** (Character input mode) repeatedly and select “半角英字” (English and sign input mode).
- For details, see the table on page 9 for instructions.

## Example: Micah

1. Press **6** once.

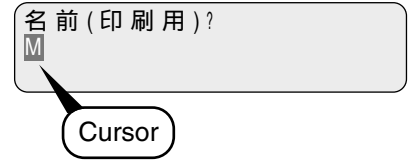

2. Press **4** six times.

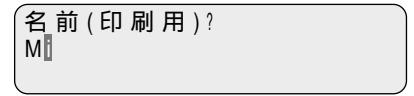

3. Press **2** six times.

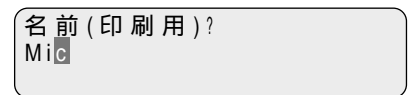

4. Press **再ダイヤル 電話帳** to move the cursor to the next space and press **2** four times.

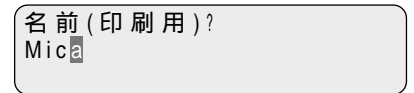

5. Press **4** five times.

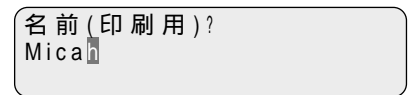

**3** Press **登録 F2** (Register).

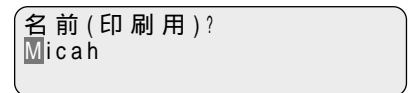
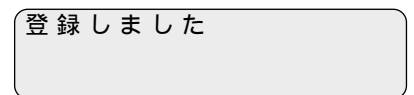

**4** Press **ストップ** (Stop).





# Automatic dialing on the main unit

## Storing names and telephone numbers in the phonebook

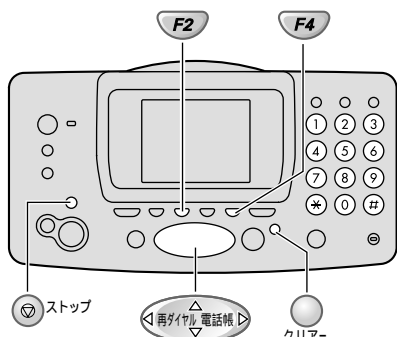

- Press (Phonebook) and (Register).
  - “XXX” shows the number of remaining stations you can store.
  - You can program up to 150 stations, including 4 pre-programmed stations.

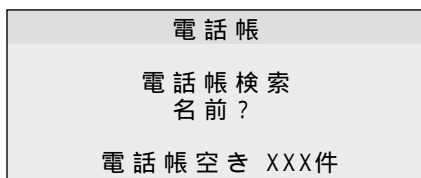

- Press (Set).

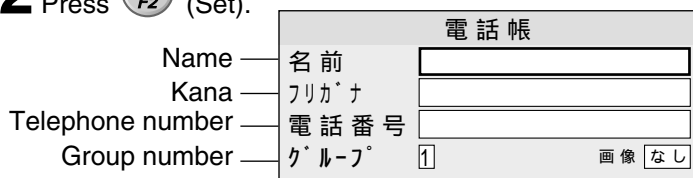

- Enter the name, up to 20 characters (see the table on page 9 for instructions), then press (Register).

- Press (Down) twice and (Set).

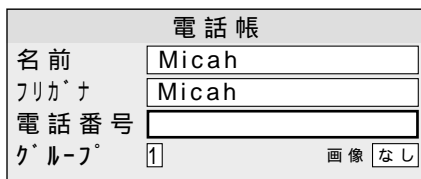

- Enter the telephone number, up to 24 digits.
  - To correct a mistake, press (Clear).

- Press (Register).

- If necessary, press (Down) and (Set), then enter the group number (1–9).

- Press (Register).

- To program other items, press (Next station) and repeat steps 2 to 9.

- Press (Stop) to exit the program.

## Making a voice call using the phonebook

- Press (Phonebook).
- Press (Search button) repeatedly until the desired name is displayed.
- Lift the handset or press (Speakerphone).

## Editing a stored name or number

- Press (Phonebook).
- Press (Search button) repeatedly until the desired name is displayed.
- Press (Edit).
- Press (Set) and edit the name (see the table on page 9 for instructions), then press (Register).
  - If you do not need to edit the name, skip to step 5.
- Press (Search button) to select the kana column.
  - If you do not need to edit the kana, skip to step 7.
- Press (Set) and enter the correct kana, then press (Register).
- Press (Search button) to select the telephone number column.
  - If you do not need to edit the telephone number, skip to step 9.
- Press (Set) and enter the correct telephone number, then press (Register).
- If necessary, press (Search button) to select the group number column.
  - If you do not need to edit the group number, skip to step 11.
- Press (Set), and enter the group number (1-9), then press (Register).
- Press (Stop) to exit the program.

# Automatic dialing on the main unit

## Storing names and telephone numbers in the speed dialer

You can store up to 9 names and telephone numbers which are stored in the phonebook. The dialing buttons (1 to 9) function as memory stations.

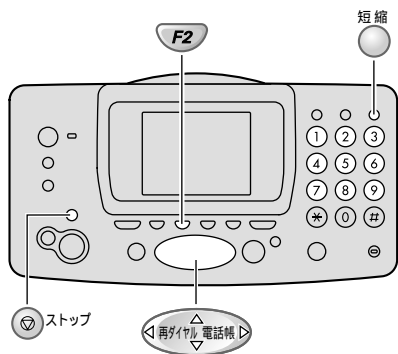

1 Press (Speed dialer).

2 Press the memory station number (1 to 9).

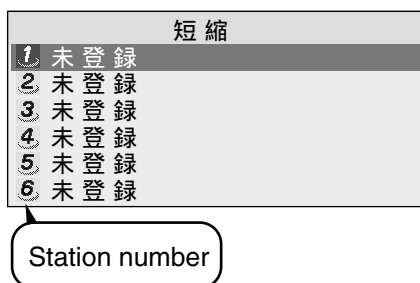

3 Press (Register).

4 Press (Search button) repeatedly until the desired name is displayed.

5 Press (Register).

- To program other items in other stations, repeat steps 2 to 5.

6 Press (Stop) to exit the program.

## Making a voice call using the speed dialer

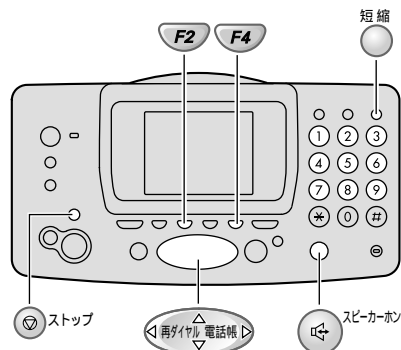

1 Press (Speed dialer).

2 Press the memory station number (1 to 9).

3 Lift the handset or press (Speakerphone).

## Erasing a name and number stored in the speed dialer

1 Press (Speed dialer).

2 Press (Search button) repeatedly to select the memory station number you want to erase.

3 Press (Erase) and (Yes).

4 Press (Stop) to exit the program.

# Automatic dialing on the portable handset

## Storing names and telephone numbers in the phonebook

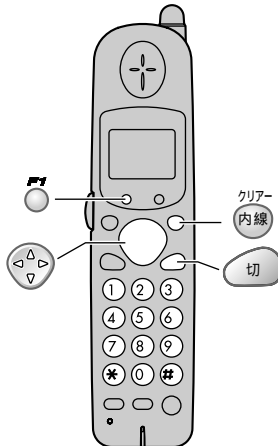

1 Press 電話帳 (Phonebook).

電話帳検索  
名前?

2 Press (Register).

- "XXX" shows the remaining station numbers you can store.
- You can program up to 150 stations, including 4 pre-programmed stations.

名前?  
空き x x x 件

3 Enter the name, up to 20 characters (see the table on page 9 for instructions).

4 Press (Register) twice.

5 Enter the telephone number, up to 24 digits.

- To correct a mistake, press (Clear).

6 Press (Register).

7 If necessary, enter the group number (1–9).

8 Press (Register).

- To program other items, repeat steps 3 to 8.

9 Press (Off) to exit the program.

## Making a voice call using the phonebook

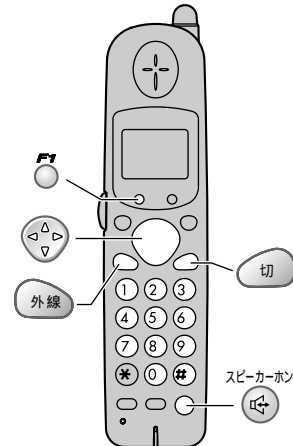

1 Press 電話帳 (Phonebook).

2 Press (Search button) repeatedly until the desired name is displayed.

3 Press (Talk) or press (Speakerphone).

## Editing a stored name or number

1 Press 電話帳 (Phonebook).

2 Press (Search button) repeatedly until the desired name is displayed.

3 Press (Edit).

4 Edit the name (see the table on page 9 for instructions), then press (Register).

- If you do not need to edit the name, press (Register) and skip to step 5.

5 Enter the correct kana, then press (Register).

- If you do not need to edit the kana, press (Register) and skip to step 6.

6 Enter the correct telephone number.

- If you do not need to edit the telephone number, skip to step 7.

7 Press (Register).

8 If necessary, enter the correct group number.

9 Press (Register).

10 Press (Off) to exit the program.

# Intercom between the main unit and portable handset

An intercom is available between the main unit and portable handset.

## Using the main unit:



### 1 ■ For single portable handset users

- ① Lift the handset.
  - When pressing **子機** (Portable handset) without lifting the handset, you can use the speakerphone. Skip step ②.
- ② Press **子機** (Portable handset).

子機 1 呼出中

### ■ For multiple portable handset users

- ① Lift the handset, then press **子機** (Portable handset).
  - When pressing **子機** (Portable handset) without lifting the handset, you can use the speakerphone.
- ② Press the portable handset number ( **1** to **4** ) which you want to call.

内線番号  
[ 12 .... ] を押す



Example : 子機 1 呼出中

### 2 Start talking.

- 3 Replace the handset or press **スピーカーホン** (Speakerphone) if using the speakerphone.

## Using the portable handset:

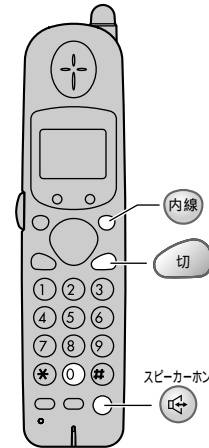

### 1 ■ For single portable handset users

Press **内線** (Intercom).

内線呼出

### ■ For multiple portable handset users

Press **内線** (Intercom), then press **0**.

### 2 Start talking.

- You can switch to the speakerphone by pressing **スピーカーホン** (Speakerphone).

### 3 Press **切** (Off) to end the intercom call.

# Intercom between portable handsets

A 2-way intercom is available between 2 portable handsets.  
 (For KX-L5CL users: An optional handset is needed when using this feature.)

## Making an intercom call

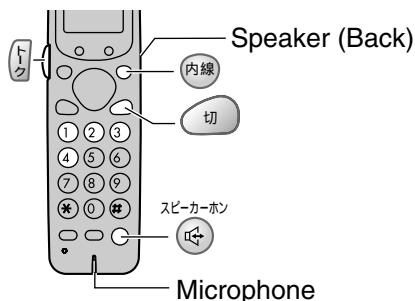

- 1** Press **内線** (Intercom) and the desired portable handset number (**1** to **4**).

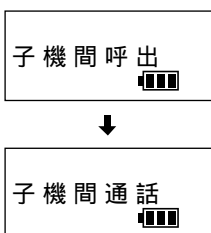

- 2** Start talking.

1. Press and hold **トク** (Talk) until a beep sounds.

- **スピーカーホン** (Speakerphone) light on

2. Start talking while holding down **トク** (Talk).

- Keep holding down **トク** (Talk) until you finish talking.

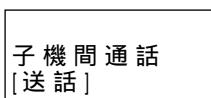

3. Release **トク** (Talk) after you finish talking.

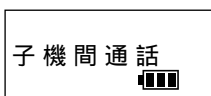

- 3** Listen to the response.

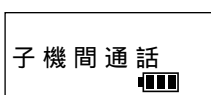
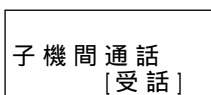

- 4** If you want to continue the conversation, repeat steps 2 and 3.

- 5** Press **切** (Off) to end the intercom call.

## Answering an intercom call

**1**

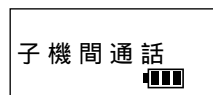
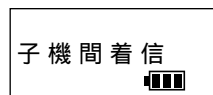

- 2** Listen to the caller.

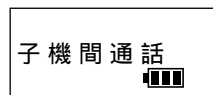
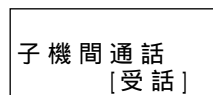

- 3** Respond to the caller.

1. Press and hold **トク** (Talk) until a beep sounds.

- **スピーカーホン** (Speakerphone) light on

2. Start talking while holding down **トク** (Talk).

- Keep holding down **トク** (Talk) until you finish talking.

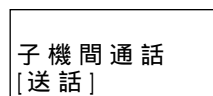

3. Release **トク** (Talk) after you finish talking.

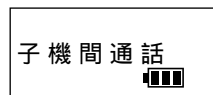

- 4** If you want to continue the conversation, repeat steps 2 and 3.

- 5** Press **切** (Off) to end the intercom call.

# Sending faxes

## Sending a fax manually

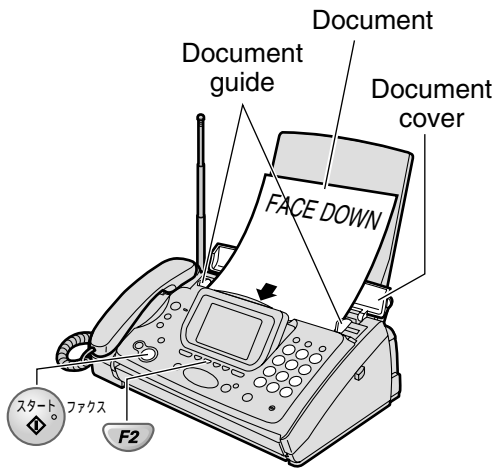

- 1 Open the document cover, and adjust the width of the document guides to the size of the document.
- 2 Insert the document (up to 5 pages) FACE DOWN until a single beep is heard.
- 3 If necessary, press (Resolution) repeatedly to select the desired setting (see below).
- 4 Dial the fax number.
- 5 Press (Fax).
  - The unit will start fax transmission.

## Sending a fax using the phonebook/speed dialer

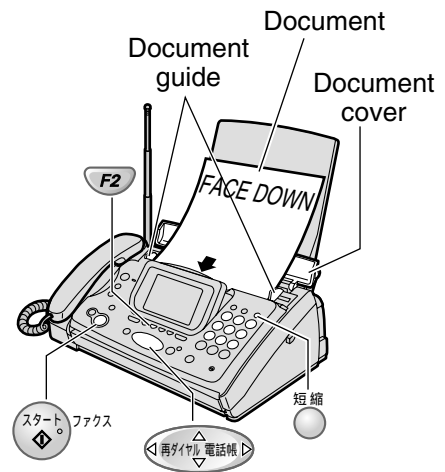

- 1 Open the document cover, and adjust the width of the document guides to the size of the document.
- 2 Insert the document (up to 5 pages) FACE DOWN until a single beep is heard.
- 3 If necessary, press (Resolution) repeatedly to select the desired setting (see below).
- 4 ■ When using the phonebook  
Press (Phonebook), then press (Search button) until the desired name is displayed.  
■ When using the speed dialer  
Press (Speed dialer), then press memory station number ( to ).
- 5 Press (Fax).
  - The unit will start fax transmission.

### To select the resolution

Select the desired resolution according to the type of document, by pressing (Resolution).

画質 = ふ つ う

(Standard) for printed or typewritten originals with normal-sized characters.

画質 = 小 さ い

(Fine) for originals with minute printing.

画質 = 写 真

(Photo) for originals containing photographs.

# Receiving faxes

You can select beforehand whether to receive faxes by “Receive in memory” or “Receive on recording paper”.

**Receive in memory:** The received fax will be stored in memory. You can check the contents on the display, (Default setting) then print them if necessary.

**Receive on recording paper:** The received fax will be printed on recording paper.

## ■ Setting/canceling “Receive in memory”

Press  (Changes each time it is pressed.)

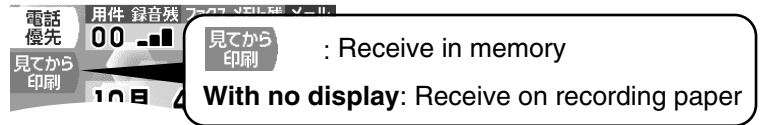

## Receiving a fax manually (AUTO ANSWER off)

Using the main unit:

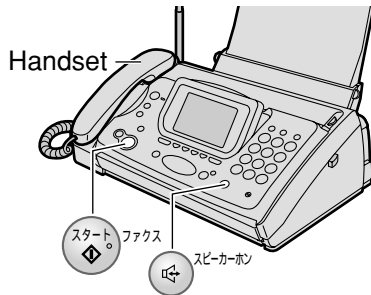

**1** When you hear a ring, lift the handset or press

 (Speakerphone) to answer the call.

**2** When: –document reception is required, –a fax calling tone (slow beep) is heard, or –no sound is heard,

press  (Fax).

**3** Replace the handset if you are using it.  
• The unit will start fax reception.

Using the portable handset:

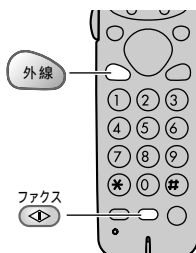

**1** When you hear a ring, lift the portable handset from the charger to answer the call.

• If the portable handset is not set on the charger, press  (Talk).

**2** When: –document reception is required, –a fax calling tone (slow beep) is heard, or –no sound is heard,

press  (Fax reception) until a single beep is heard.

• The main unit will start fax reception.

## Setting ANSWER mode

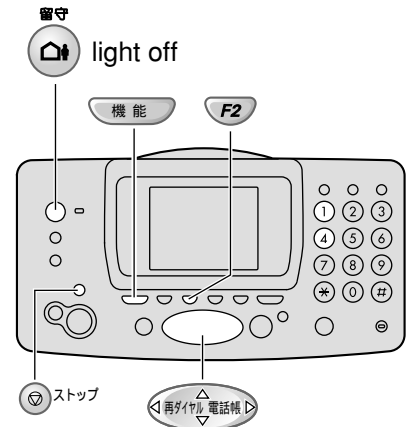

If the  (Auto answer) light is on, turn it off by

pressing .

When AUTO ANSWER mode is off, the unit provides two types of receiving modes: “電話優先” (Telephone) mode and “ファクス優先” (Fax/Telephone) mode.

**Telephone mode (電話優先)** –Pre-selected setting: Select this mode when you plan to answer the calls yourself.

When receiving calls, you have to answer all calls manually.

**Fax/Telephone mode (ファクス優先):** Select this mode when you are near the unit and want to use it to receive voice calls yourself and fax calls automatically.

Change the setting if you want to use this mode.

1. Press  (Function) and  .

2. Press  (Search button) repeatedly to select the desired mode.

在宅時の受け方  
電話優先, ファクス優先

means “Telephone mode” means “Fax/Telephone mode”

3. Press  (Register).

4. Press  (Stop).



# Receiving faxes

## Display when faxes are received in memory

When new faxes are received in memory,  (Fax list) will flash.

(Flashing will stop after all new faxes have been displayed or printed.)

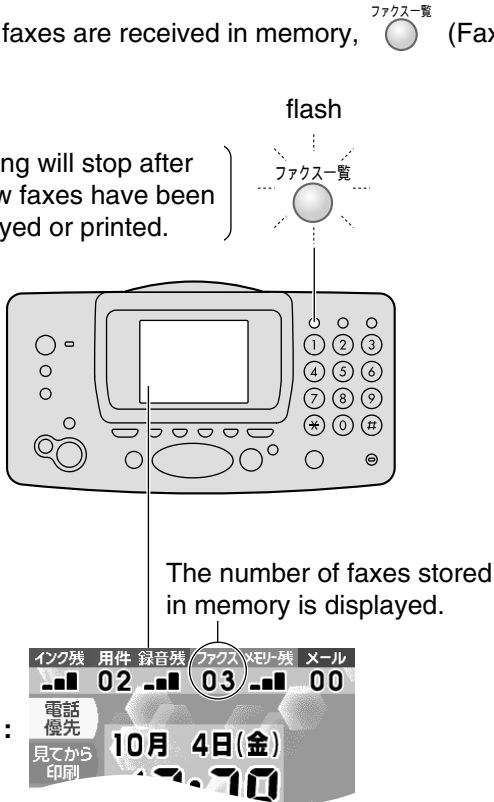

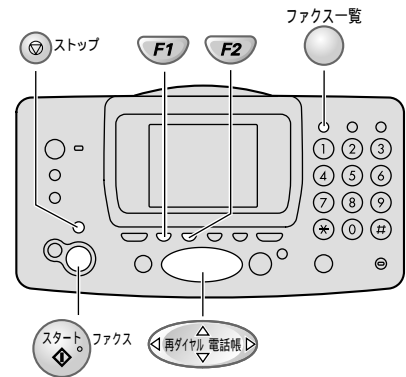

## Viewing faxes stored in memory



**1** Press  (Fax list).

**2** Press  (Search button) to select the desired fax to display.

新規(*マーク)02件 合計08件 (11ページ)				
日付	時刻	ペ-ジ	相手局名	
*01 9月10日	21:59	01	098765111	
*02 9月10日	13:40	03	098765222	
03 9月 9日	8:05	01	098765333	
04 8月25日	22:15	02	098765444	
05 7月10日	9:00	01		

**3** Press  (Display) to see the fax (see below for detail).  
 • To print the displayed page, press  (Start).

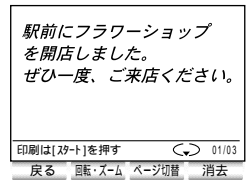

**4** To view other faxes, press  (Return) and repeat steps 2–3. To exit the program, press  (Stop).

### Information about display

#### ■ To scroll display contents

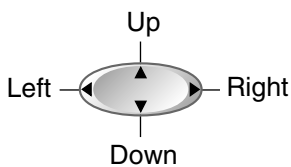

(Example)

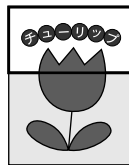



● **Normal display** (can be scrolled up and down.)



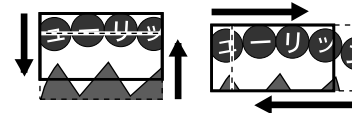

● **Enlarge display** (can be scrolled up, down, left and right.)



#### ■ To enlarge or reduce content

**Enlarge** : Press  (Turn-Zoom)  (Zoom+).

**Reduce** : Press  (Turn-Zoom)  (Zoom-).

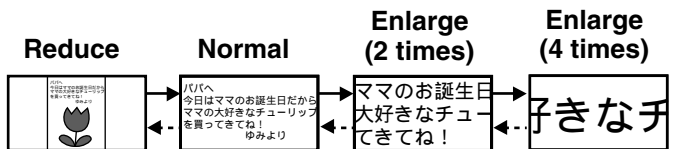

#### ■ Scroll pages

**To show the next page:** Press  (Scroll page)  (Next page).

**To show the previous page:** Press  (Scroll page)  (Previous page).

#### ■ To turn display contents

Press  (Turn-Zoom)  (Turn).

(Example)

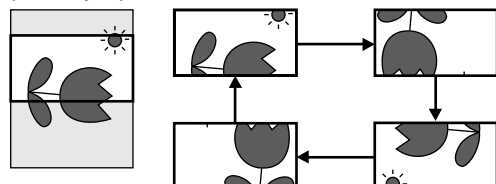

# Receiving faxes

## Printing a specific fax stored in memory

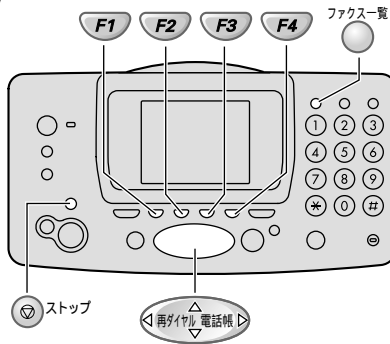

**1** Press (Fax list).

### 2 ■ To print a specific fax

Press (Search button) to select the desired fax to print, then press (Print a specific fax).

#### ■ To print new fax only

Press (Change button function) twice, then press (Print new fax).

#### ■ To print only a required page

1. Press (Change button function) twice, then press (Print a page).
2. Enter the start page and press (Set).
3. Enter the end page and press (Set).

#### ■ To print all faxes

Press (Change button function), then press (Print all).

新規(★マーク) 02件 合計08件 (11ページ)				
	日付	時刻	ページ	相手局名
*01	9月10日	21:59	01	0987651111
*02	9月10日	13:40	03	0987652222
03	9月9日	8:05	01	0987653333
04	8月25日	22:15	02	0987654444
05	7月10日	9:00	01	

ボタン切替 表示 個別印刷 個別消去

**3** After printing, the following is displayed.

Do you delete the printed contents?

- If you want to delete the fax, press (Yes).

- If you want to hold the fax, press (No).

**4** Press (Stop).

## Deleting a specific fax stored in memory

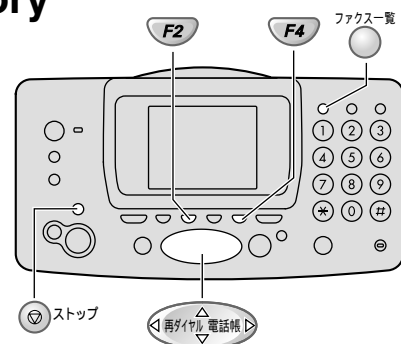

**1** Press (Fax list).

**2** Press (Search button) to select the desired fax to delete.

新規(★マーク) 02件 合計08件 (11ページ)				
	日付	時刻	ページ	相手局名
*01	9月10日	21:59	01	0987651111
*02	9月10日	13:40	03	0987652222
03	9月9日	8:05	01	0987653333
04	8月25日	22:15	02	0987654444
05	7月10日	9:00	01	

**3** Press (Delete a specific fax).

Do you delete the fax?

or

Do you delete the new fax?

**4** If you want to delete the fax, press (Yes).

- If you want to hold the fax, press (No).

**5** If you want to delete other faxes, repeat steps 2–4.

**6** Press (Stop).

# Receiving faxes

## Receiving a fax automatically (AUTO ANSWER on)

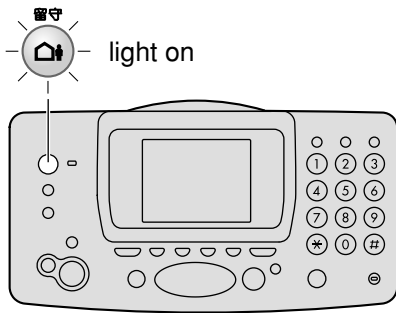

**1** If the (Auto answer) light is off, turn it on by pressing .

**2** When receiving a call, the unit will receive a fax document or record a voice message automatically depending on the caller's request.

## Recording your own greeting message

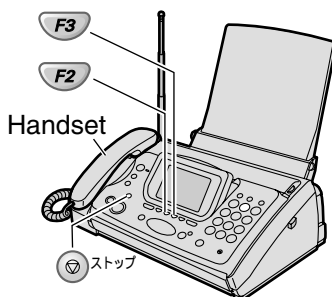

You can record your own greeting message. When receiving a call, it will be played to callers instead of the pre-recorded Japanese greeting message.

- 1** Press (Record), then press .
- 2** Lift the handset.
- 3** Press (Set) and record your greeting message, up to 16 seconds, using the handset.
- 4** Press (Stop), then replace the handset.
  - Your greeting message will be played back automatically.

## Setting AUTO ANSWER mode

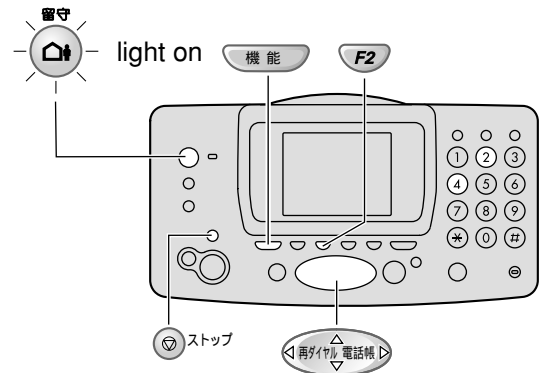

AUTO ANSWER mode will work when the (Auto answer) light is on.

AUTO ANSWER mode provides three types of receiving modes: “ファクス / 留守電” (Fax/Answering device) mode, “ファクス専用” (Fax only) mode and “留守電専用” (Answering device only) mode.

### Fax/Answering device mode (ファクス / 留守電)

–Pre-selected setting:

Select this mode when you want to receive all voice and fax calls automatically.

### Fax only mode (ファクス専用):

Select this mode when you wish to use the unit only as a fax machine.

### Answering device only mode (留守電専用):

Select this mode when you wish to use the unit only as a telephone answering device.

Change the setting if you want to use the fax only mode or answering device only mode.

- 1.** Press (Function), then press .
- 2.** Press (Search button) repeatedly to select the desired receiving mode.

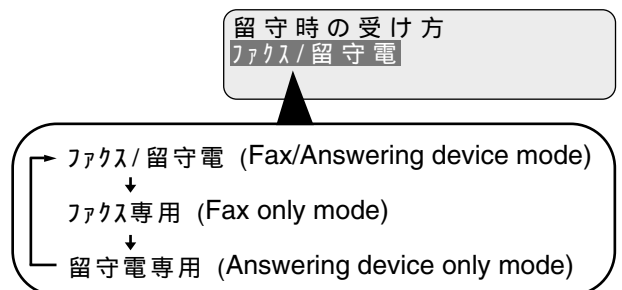



- 3.** Press (Register), then press (Stop).

# Operating the built-in answering device

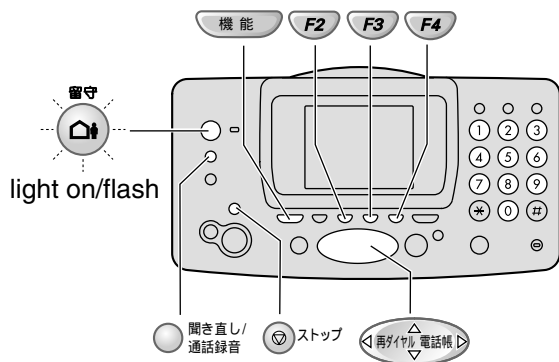
## Activating the answering device



- 1 Turn the  (Auto answer) light on by pressing .
- 2 When receiving a call, a greeting message will be played and the unit will record a voice message.
  - To record your own greeting message, see page 19.

## Listening to recorded messages



When new messages are recorded, the  (Auto answer) light will flash.

Press  to listen to recorded messages.

After the messages are played back, the following will be displayed.

Do you delete the \_\_\_\_\_ messages played back?

再生した用件を  
消去しますか？

- To erase the messages, press  (Yes).
- To save the messages, press  (No).



## Listening to all of the recorded messages

Press  (Replay/Record).

After the messages are played back, the following will be displayed.

Do you delete the \_\_\_\_\_ messages played back?



再生した用件を  
消去しますか？

- To erase the messages, press  (Yes).
- To save the messages, press  (No).



## Erasing a specific message

Press  (Erase) while listening to the message you want to erase, then press  (Yes).

## Erasing all of the recorded messages





- 1 Press  (Record), then press  (Set).
- 2 Press  (Yes).

## Erasing your own greeting message

- 1 Press  (Record), then press .
- 2 Press  (Yes).
  - The pre-recorded Japanese greeting message will be played when you receive a call.



## Operating the answering device from a remote location

**Preparation: Programming the remote operation ID**

1. Press  (Function), then press  .
2. Enter any 4-digit number (remote operation ID) except \* or #.
3. Press  (Register).
4. Press  (Stop).

**Operation: Listening to a recorded message from a remote location**

Turn the  (Auto answer) light on before you go out. Remote operations are available only from a touch tone telephone.

1. Call your unit.
2. Enter the remote operation ID during the greeting message.
3. Press  or wait 4 seconds.
  - Only the new recorded messages will be played back.
  - To listen to all the recorded messages, press  after the new messages have been played back.

# L-mode service

## Using L-mode service

“L-mode” is a convenient service of NTT offering with web browsing and e-mail.

**To use L-mode service, please contract with NTT.**

### Application fee

Subscription fee/ Installation charge	Free
L-mode usage charge	200 yen/month
Internet connection charge	100 yen/month
Transmission charges	Call charges to the access point according to usage time

- According to charged sites, charges are added separately.



## Setting up L-mode service

You should set up your unit before using L-mode service.

### Important:

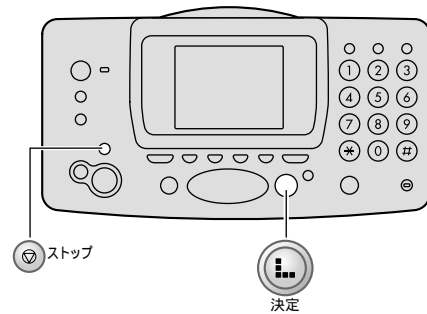
- You should set up your unit after subscription of “L-mode” service is completed.  
You cannot set up your unit until the service becomes available.
- When your unit is turned off, the required data for L-mode is deleted and L-mode service will not be available.  
The following setting is necessary to use L-mode service again after switching on the power supply.



- 1** Press  (L-mode) twice.
  - The required data for L-mode will be downloaded.
- 2** Press  (L-mode) when the following is displayed.

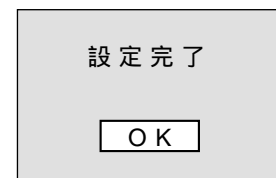

- The top menu is displayed and you can use L-mode service continuously. (The transmission charge will be added.)

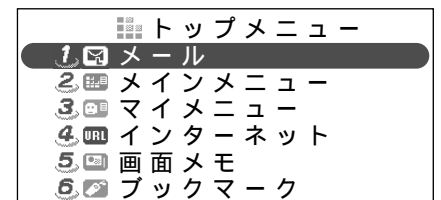

- 3** Press  (Stop).

# L-mode service

## Browsing the web using the L-mode menu

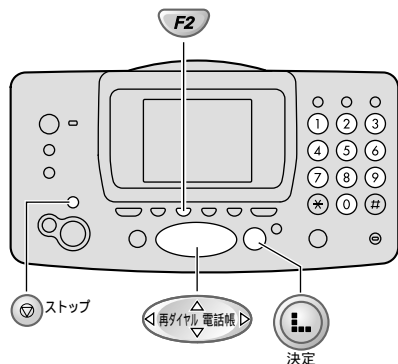

- 1 Press (L-mode), then press .  
 • The line will be connected to the L-mode center.

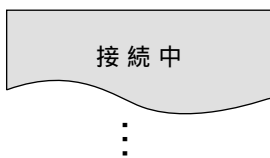

- 2 Press (Search button) to select the desired item to browse, then press (L-mode).  
 (Repeat this operation to access the desired item.)

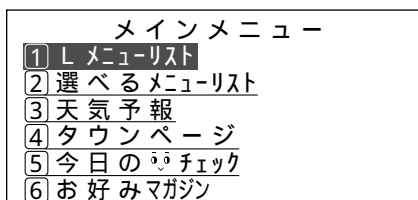

- When the password is required:

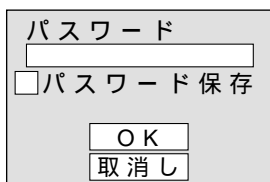

- Press (L-mode) and enter the 4-digit password (the default setting is "0000"), then press (Register).  
 (To enter the characters, see the table on page 9 for instructions.)

- 3 Press (Stop) twice to finish browsing.

## Browsing the web by entering the URL

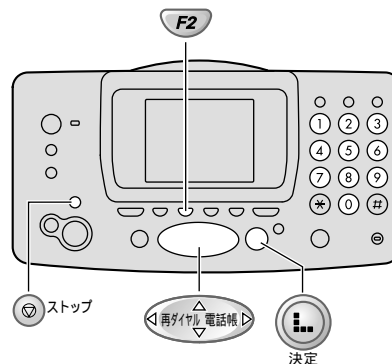

- 1 Press (L-mode), then press .
- 2 Press (L-mode) and enter the URL, up to 500 characters (see the table on page 9 for instructions), then press (Register).



- 3 Press (Down) to select "OK", then press (L-mode).



- The line will be connected to the L-mode center.



- 4 Press (Stop) twice to finish browsing.

# L-mode service

## Operation on the web

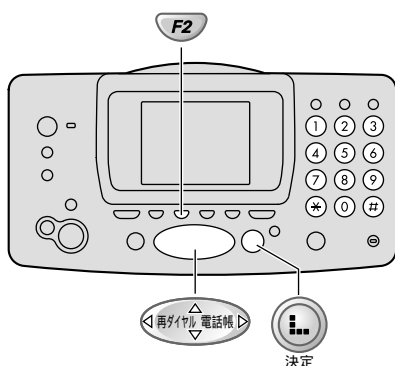

### ■ To scroll display contents

Press (Search button).

### ■ To browse the web which is linked

Press (Search button) to select the desired item (underlined), then press (L-mode).

1. 自宅周辺の天気  
2. 全国のお天気

### ■ To go back to the previous page

Press (Back).

### ■ To go to the next page

Press (Forward).

### ■ To enter the characters

1. Press (Search button) to select the desired text box to enter the characters.
2. Press (L-mode) and enter the characters (see the table on page 9 for instructions), then press (Register).

### ■ To select the item with the radio button

1. Press (Search button) to select the desired item.

性別を選ぶ

男性  
 女性

2. Press (L-mode).

性別を選ぶ

男性  
 女性

### ■ To select the item by checking the check box

1. Press (Search button) to select the desired item.

地域を選ぶ

北海道	<input checked="" type="checkbox"/>	東京	<input type="checkbox"/>
東北	<input type="checkbox"/>	大阪	<input type="checkbox"/>
関東	<input type="checkbox"/>		

2. Press (L-mode).

地域を選ぶ

北海道	<input type="checkbox"/>	東京	<input type="checkbox"/>
東北	<input checked="" type="checkbox"/>	大阪	<input type="checkbox"/>
関東	<input type="checkbox"/>		

### ■ To select the item from pull-down menu

1. Press (Search button) to select the desired item.

性別は？

2. Press (L-mode).
  - The choice (pull-down menu) is displayed.

性別は？

3. Press (Search button) to select the desired item.

4. Press (L-mode).

# L-mode service

## Sending an e-mail

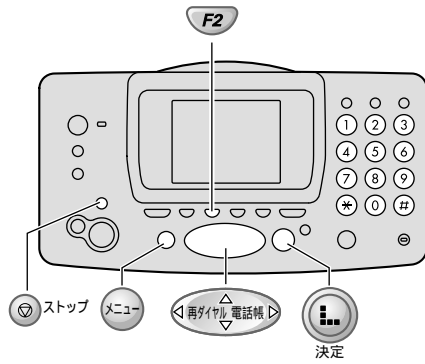

**1** Press (L-mode), then press **1 1**.

**2** Press (L-mode).

E-mail address	宛先 (アドレス帳は[メニュー])
Title	题名
Message	本文 (送信は[メニュー])

**3** Enter the desired e-mail address, up to 50 characters (see the table on page 9 for instructions), then press (Register).

• You can enter the e-mail address using the addressbook.

1. Press (Menu) and **3**.

2. Press (Search button) to select the desired party.  
(Or enter the other party's initial of the name, then press .)

3. Press (Set).

**4** Press (Search button) to select the title column, then press (L-mode).

宛先 (アドレス帳は[メニュー])	yuka@XXX.ne.jp
题名	
本文 (送信は[メニュー])	

**5** Enter the title of your e-mail, up to 60 characters (see the table on page 9 for instructions), then press (Register).

**6** Press (Search button) to select the message column, then press (L-mode).

宛先 (アドレス帳は[メニュー])	yuka@XXX.ne.jp
题名	予約の件
本文 (送信は[メニュー])	

**7** Enter your e-mail message, up to 2000 characters (see the table on page 9 for instructions), then press (Register).

### 8 ■ To send the e-mail

Press (Menu) and **1**.

• Your e-mail will be sent.

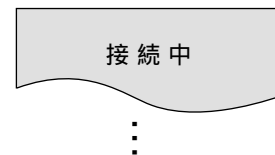

### ■ To stop writing the e-mail and save it

Press (Menu) and **2**.

**9** When the following is displayed, press (L-mode) to disconnect the line.

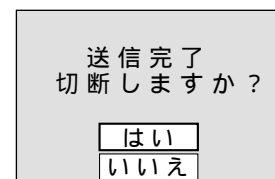

**10** Press (Stop).



# L-mode service

## Storing e-mail addresses in the addressbook

You can program up to 50 addresses.

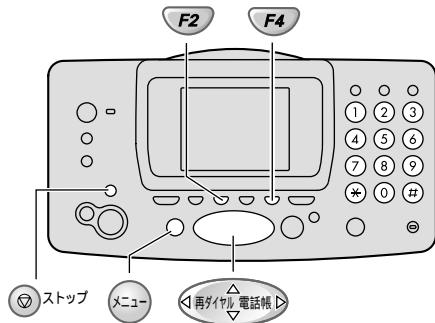

- 1 Press **メニュー** (Menu) and **2**, then press **登録** (Register).

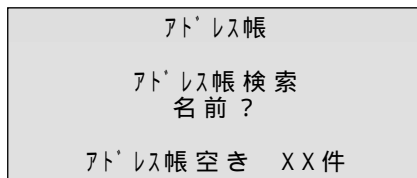

- 2 Press **決定** (Set).

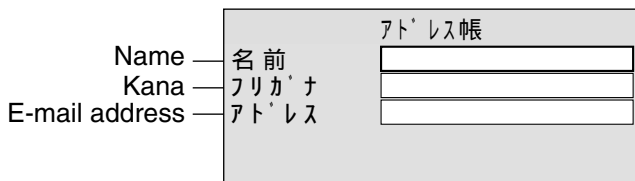

- 3 Enter the name, up to 20 characters (see the table on page 9 for instructions), then press **登録** (Register).

- 4 Press **再ダイヤル電話帳** (Search button) to select the e-mail address column, then press **決定** (Set).



- 5 Enter the e-mail address, up to 50 characters (see the table on page 9 for instructions), then press **登録** (Register).

- To program another party, press **次の登録** (Next party) and repeat steps 2 to 5.

- 6 Press **ストップ** (Stop) to exit the program.

## Editing/deleting a stored e-mail address

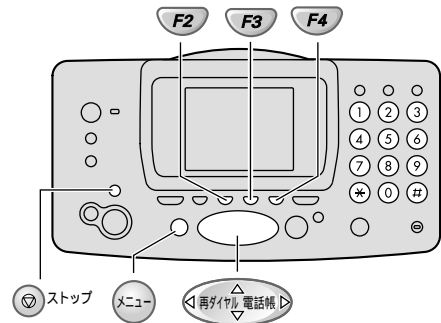

- 1 Press **メニュー** (Menu) and **2**.

- 2 Press **再ダイヤル電話帳** (Search button) repeatedly until the desired name is displayed.

### 3 ■ To edit the party

Press **修正** (Edit).

### ■ To delete the party

Press **消去** (Delete) and **はい** (Yes), then go to step 9.

- 4 Press **決定** (Set) and edit the name (see the table on page 9 for instructions), then press **登録** (Register).
  - If you do not need to edit the name, skip to step 5.

- 5 Press **再ダイヤル電話帳** (Search button) to select the kana column.
  - If you do not need to edit the kana, skip to step 7.

- 6 Press **決定** (Set) and enter the correct kana, then press **登録** (Register).

- 7 Press **再ダイヤル電話帳** (Search button) to select the e-mail address column.
  - If you do not need to edit the e-mail address, skip to step 9.

- 8 Press **決定** (Set) and enter the correct e-mail address, then press **登録** (Register).

- 9 Press **ストップ** (Stop) to exit the program.

## Receiving an e-mail

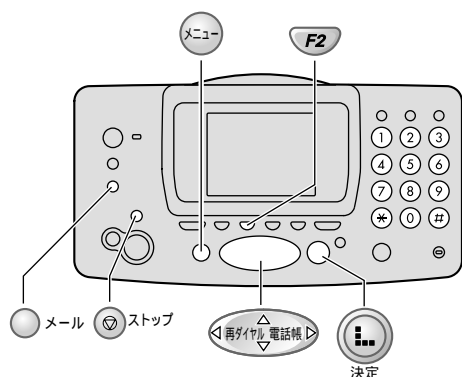

- 1** Press メール (Mail) when its indicator is flashing.
- The new e-mail will be received.

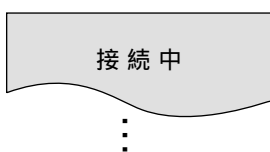

- 2** When the following is displayed, press 決定 (L-mode).
- The connection with the L-mode center will be disconnected.

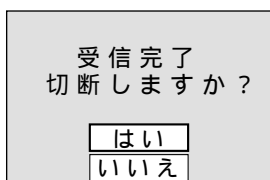

- 3** Press <再ダイヤル/電話帳> (Search button) to select the desired e-mail.

(Example)

受信メールの一覧	
17:00	予約の件
12:30	こんにちは
08/31	遊びに行こう

Selected e-mail

- 4** Press 決定 (L-mode) to read the e-mail.

- To print the e-mail, press **4** and 決定.
- To delete the e-mail, press **5** and 決定.

### ■ To reply to the e-mail

- Press メニュー (Menu) and **2**.
- Press <再ダイヤル/電話帳> (Search button) to select the message column ("本文"), then press 決定 (L-mode).
- Enter your message, up to 2000 characters (see the table on page 9 for instructions), then press 登録 F2 (Register).
- Press メニュー (Menu) and **1**, then press 決定 (L-mode).

### ■ To forward the e-mail

- Press メニュー (Menu) and **3**.
- Press 決定 (L-mode).
- Enter the desired e-mail address, up to 50 characters (see the table on page 9 for instructions), then press 登録 F2 (Register).
- If necessary, add your message.
  - Press <再ダイヤル/電話帳> (Search button) to select the message column ("本文"), then press 決定 (L-mode).
  - Enter your message (see the table on page 9 for instructions), then press 登録 F2 (Register).
- Press メニュー (Menu) and **1**, then press 決定 (L-mode).

- 5** Press ストップ (Stop).

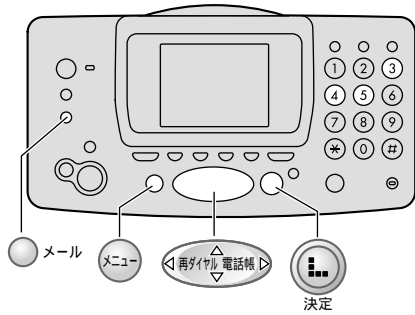

## Viewing the received e-mail

1 Press **メール** (Mail), then press **3**.

**メール**: An e-mail which has not been read yet

受信メールの一覧	
17:00	予約の件
09/01	こんにちは
08/31	遊びに行こう
08/25	連絡です

Shows when the e-mail arrived at the L-mode center.

Title of the e-mail

2 Press **再ダイヤル電話帳** (Search button) to select the desired e-mail, then press **決定** (L-mode).

09/01 12:30	mika@XXX.co.jp	こんにちは
こんにちは お元気でしょうか？		

## Viewing the sent e-mail

1 Press **メール** (Mail), then press **4**.

Shows when the e-mail was sent.

送信済メールの一覧	
12:30	こんにちは
09/07	予約の件
09/04	ビッグニュースがあ だよ 週末の予定

2 Press **再ダイヤル電話帳** (Search button) to select the desired e-mail, then press **決定** (L-mode).

09/07 17:45	yuka@XXX.co.jp	予約の件
日曜日の8時に駅前に集合し てください。 会費は、3,000円の予定		

### ■ To print the displayed e-mail

Press **メニュー** (Menu) and **3**, then press **決定** (L-mode).

### ■ To delete the displayed e-mail

Press **メニュー** (Menu) and **4**, then press **決定** (L-mode).

## Viewing the unsent e-mail

1 Press **メール** (Mail), then press **5**.

Shows when the e-mail was saved.

未送信メールの一覧	
20:30	お礼
09/01	キャンプに行かない

2 Press **再ダイヤル電話帳** (Search button) to select the desired e-mail to display, then press **決定** (L-mode).

09/01 21:30	tomoko@XXX.co.jp	キャンプに行かない
こんばんは。 いつかキャンプに行かない？ 場所は		

### ■ To edit the displayed e-mail and send it

Press **メニュー** (Menu) and **3**, then go to step 2 on page 24.

### ■ To print the displayed e-mail

Press **メニュー** (Menu) and **4**, then press **決定** (L-mode).

### ■ To delete the displayed e-mail

Press **メニュー** (Menu) and **5**, then press **決定** (L-mode).

# Specifications

KX-L5CL/L5CW	Main unit	Portable handset	Battery charger
<b>Power supply</b>	AC 100 V (50 Hz/60 Hz)	Ni-Cd battery (Part no. KX-FAN37) DC 2.4 V, 600 mAh	AC adaptor (Part no. PFAP1009) AC 100 V (50 Hz/60 Hz) DC 7.5 V, 100 mA
<b>Power consumption</b>	Transmission: Approx. 20 W Reception: Approx. 25 W Copy: Approx. 25 W Stand by: Approx. 1.2 W Maximum(*1): Approx. 130 W		<ul style="list-style-type: none"> <li>• Charging: Approx. 1.1 W</li> <li>• Stand by: Approx. 0.4 W</li> </ul>
<b>Dimensions (H x W x D)</b>	Approx. 139 X 344 X 254 mm (without projections) Approx. 378 X 344 X 301 mm (recording paper tray installed, without projections)	Approx. 181 X 44 X 40 mm (without projections) Approx. 190 X 44 X 40 mm (included call/charge indicator)	Approx. 72 X 72 X 90 mm
<b>Mass (Weight)</b>	Approx. 3.9 kg (10 m ink film installed)	Approx. 170 g (battery installed)	Approx. 77 g
<b>Operating environment</b>	5 °C – 35 °C, 45 % – 85 % RH (Relative Humidity)		

KX-L5CL/L5CW	Main unit
<b>Applicable line</b>	Public Switch Telephone Network (Tone/Pulse), F-Net, NCC Lines
<b>DC resistance</b>	320 Ω (*2)
<b>Compatibility</b>	G3 compatible
<b>Document size</b>	B4 – A5 (Max. 257 – Min. 146 mm in width, Max. 800 – Min. 128 mm in length)
<b>Effective scanning size</b>	252 mm (B4) 208 mm (A4)
<b>Effective printing size</b>	202 mm (A4 size plain paper)
<b>Transmission time</b>	Approx. 15 s/page (Original mode) (*3)
<b>Modem speed</b>	9,600 / 7,200 / 4,800 / 2,400 bps; Automatic fallback
<b>Halftone level</b>	64-level
<b>Scanning density</b>	Horizontal: 8 pels/mm Vertical: 7.7 lines/mm (Fine/Photo), 3.85 lines/mm (Standard)
<b>Scanner type</b>	Contact image sensor
<b>Printer type</b>	Thermal transfer printing on plain paper
<b>Data compression system</b>	Modified Huffman (MH), Original mode
<b>Recording paper size</b>	A4: 210 mm x 297 mm (Plain paper)
<b>Answering device</b>	Greeting message: Digital recording system (up to 16 sec) Pre-recording greeting message ICM Recording: Digital recording system (Approx. 23 min. in total) (*4)
<b>Memory capacity</b>	Max. Approx. 50 pages (Only receiving fax etc.) (*5) Max. Approx. 23 min. (Only recording message) (*4)

\*1 When copying a 100% black document.

\*2 If you cannot make a call due to DC resistance, consult your dealer.

\*3 Transmission speed is based on an A4-size document of 700 characters sent in standard resolution at 9,600 bps. The actual transmission speed depends upon the contents of the page, resolution, telephone line conditions and capability of the other party's machine.

\*4 If there is a silent pause, the total recording time will be longer.

\*5 The memory capacity is based on an A4-size document of 700 characters.