

Series 41500E

Plain-paper fax machines

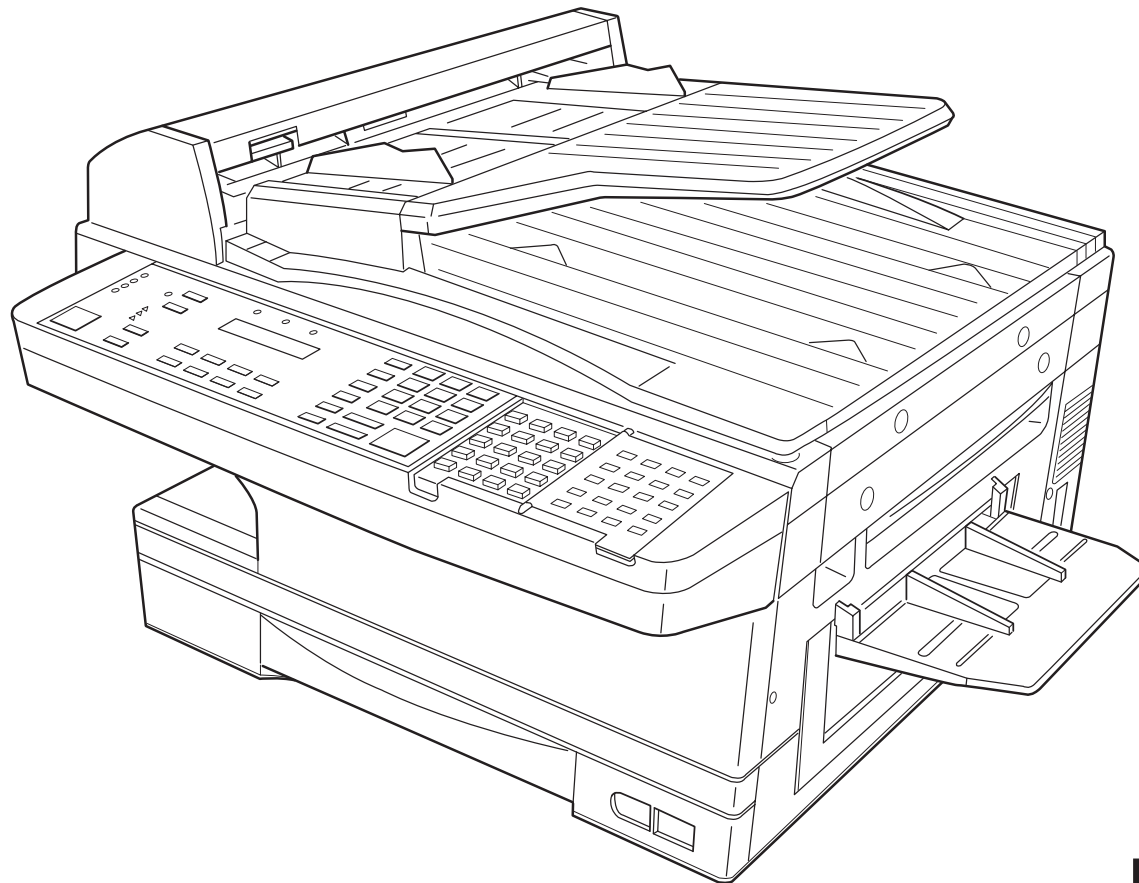

MFX-1500E Operating Instructions

Muratec[™]
The Fax Specialists.

MFX-1500E Quick Reference

One-Touch Keys

<u>Press</u>		<u>To:</u>	
Program	A	1	Enter
"	"	2	Enter
"	"	3	Enter

Speed-Dial Numbers

Program	B	1	Enter	Enter a speed dial number
"	"	2	Enter	Erase a speed dial number
"	"	3	Enter	Print a list of speed dial numbers

Programmable One-Touch Keys

Program	C	1	Enter	Enter a programmable key
"	"	2	Enter	Erase a programmable key
"	"	3	Enter	Print a list of programmable keys

Polling Documents

Program	D	1	Enter	Store a polling document
"	"	2	Enter	Erase a polling document
"	"	3	Enter	Print a polling document

Soft Key Features

Program	E		Enter	Set a Soft Key
---------	---	--	-------	----------------

Delayed Commands

Program	F	1	Enter	Print a list of delayed commands
"	"	2	Enter	Print a stored document

Activity Journal and Reports

Program	G	1	Enter	Turn the journal printout on or off
"	"	2	Enter	Print a activity journal
"	"	3	Enter	Set the type of report
"	"	4	Enter	Set the order for the reports

Print a List of Groups

Program	H		Enter	Print a list of groups
---------	---	--	-------	------------------------

EasyStart Settings

Program	I		Enter	Enter EasyStart settings
---------	---	--	-------	--------------------------

User Settings

Program	J	01	Enter	Review / change your scan settings
"	"	02	Enter	Review / change your print settings
"	"	03	Enter	Set copy protection
"	"	04	Enter	Set the dialing pause
"	"	05	Enter	Set # of rings before auto answer
"	"	06	Enter	Set the redial
"	"	07	Enter	Select ECM mode
"	"	08	Enter	Set a passcode
"	"	09	Enter	Create a closed network
"	"	10	Enter	Set security transmission
"	"	11	Enter	Block junk fax
"	"	12	Enter	Set the service mode
"	"	13	Enter	Select memory transmission
"	"	14	Enter	Set confirmation stamp
"	"	15	Enter	Set PIN mode
"	"	16	Enter	Protect passcode
"	"	17	Enter	Set Quick Transmission
"	"	18	Enter	Set Image Rotation
"	"	19	Enter	Select silent mode

MML item number: D71-90430-60

MAI order number: OMMFX1500E



Press

Program	J	20	Enter	Set DRD
"	"	21	Enter	Print machine settings

Cover Page

Program	K	1	Enter	Select the cover page option
"	"	2	Enter	Enter cover page information
"	"	3	Enter	Print cover page

Numbering Pages

Program	L		Enter	Set the number of pages
---------	---	--	-------	-------------------------

Department Codes

Program	M	1	Enter	Set the department protection
"	"	2	Enter	Set the department code
"	"	3	Enter	Turn department code setting on/off
"	"	4	Enter	Print department time list
"	"	5	Enter	Clear department time list

Batch Transmission

Program	N	1	Enter	Create or modify batch box
"	"	2	Enter	Print list of batch boxes
"	"	3	Enter	Print list of batch documents
"	"	4	Enter	Print batch document
"	"	5	Enter	Erase batch box
"	"	6	Enter	Erase batch document

Security Operations

Program	O	1	Enter	Set security reception
"	"	2	Enter	Print security reception document

F-Code Feature

Program	P	1	Enter	Set F-Code box
"	"	2	Enter	Print list of F-Code boxes
"	"	3	Enter	Print list of F-Code documents
"	"	4	Enter	Print F-Code document
"	"	5	Enter	Erase F-Code box
"	"	6	Enter	Erase F-Code document
"	"	7	Enter	Store F-Code document

Fax Forward

Program	Q	1	Enter	Set Fax forward
"	"	2	Enter	Print a list of transfer pattern

Reset Printer Option

Program	R		Enter	Reset printer option
---------	---	--	-------	----------------------

(Printer function requires optional equipment.)

PC-to-Fax Operations

Program	S	1	Enter	Begin a PC-to-Fax scan
"	"	2	Enter	Set RS-232C
"	"	3	Enter	PC-Fax Initialization

(PC-to-fax functions require optional equipment.
See your authorized Muratec dealer for details.)

Muratec America, Inc.
6400 International Parkway
Suite 1500
Plano, Texas 75093
<http://www.muratec.com>

Muratec™
The Fax Specialists.

Welcome ...

Thank you!

Thanks for selecting a Muratec fax machine for your business.

Before you begin, please note that before your fax can be used and before you can turn on power to the unit for the first time, there are important precautions to take. Please see page 1.7 for more information.

muratec™

Trademarks

Muratec, the Muratec logo and all Muratec fax product names contained herein are trademarks of Muratec America, Inc.

ENERGY STAR is a registered mark of the United States Environmental Protection Agency.

Copyright

Copyright © 1999 by Muratec America, Inc. All rights reserved.



As an Energy Star® partner, Muratec America, Inc., has determined that this product meets the Energy Star guidelines for energy efficiency.



Super G3 is an extension of Group 3 fax technology standards, allowing the use of high-speed ITU-T v.34 bis modems for 33.6 Kbps transmission and high-speed protocols for rapid handshaking.

JBIG — Joint Bi-level Image experts Group, the new ITU-T standard image data compression method. As JBIG compresses the data more efficiently than MMR, it is especially effective when transmitting halftone (grayscale) image document.

This manual and any updates to it can be found online at www.muratec.com
Go to the "Products" section of this site, then click on "*MFX-1500E*"

Before using your Muratec fax machine

Where to set up your fax machine

Follow these guidelines when setting up your fax machine:

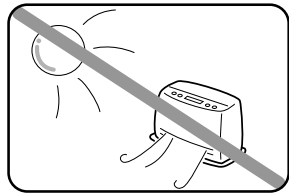

Away from direct sunlight

To avoid overheating, set up your fax machine away from direct sunlight or a heater.

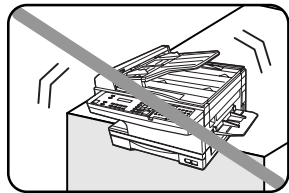

Level, and vibration-free

To avoid damage to the machine or injuries, set the fax machine up in a level, vibration-free location.

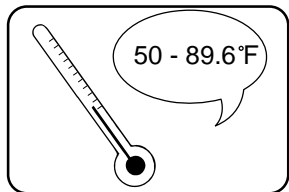

Avoid extreme high / low temperature

Use your fax machine within the temperature range of 50° F to 89.6° F (10° C to 32° C).

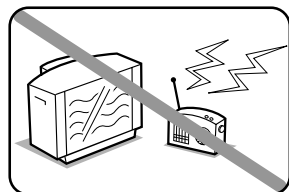

Away from a television or radio

Many appliances and office equipment, including televisions, radios, copy machines, air conditioners and computers, can generate electronic noise that can interfere with the operation of your fax machine.

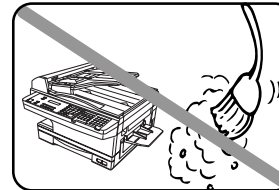

Clean

Dust buildup can damage your fax. Periodically clean your fax machine as described in the operating instructions. **Do not use a dust cover**, which can cause damaging overheating.

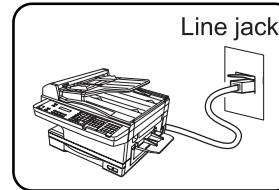

Near a phone jack

Your fax machine uses a standard (modular) telephone jack, also known as an RJ-11.

Space around the fax machine

To ensure proper ventilation and easy operation, set up the machine in an area that meets the minimum requirements for clearance as illustrated below.

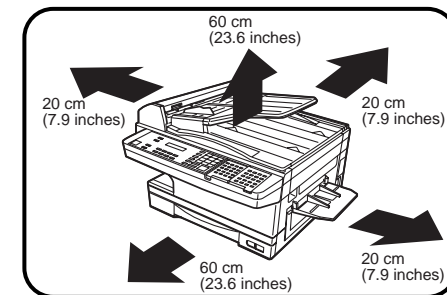

Power requirements

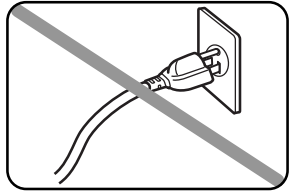

Plug in the power cord

Plug the power cord carefully and completely into a wall outlet. Do not leave any portion of the electrical cord's metal plugs exposed. Doing so could cause a fire and poses a risk of electrical shock.

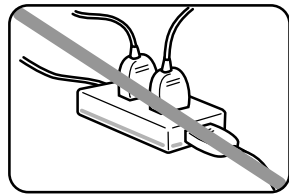

Do not share an extension cord connector with other plugs

It can cause electrical shock.

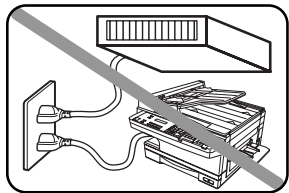

Do not share an outlet with a large appliance

High-consumption appliances such as a refrigerator or air conditioner can cause "draw-downs" which could damage your fax machine.

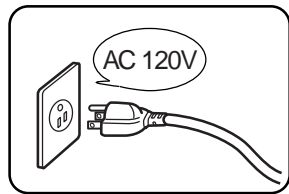

120 VAC outlet

Use a standard three-pronged 120 V electrical outlet to power your fax machine. Using any other electrical outlet will cause damage to your fax.

For domestic use only

Never use your fax machine outside the country in which you purchased it. Doing so may violate telecommunication and safety regulations of that country, and variations in electrical and telephone standards can cause poor performance and damage to your fax.

General Precautions

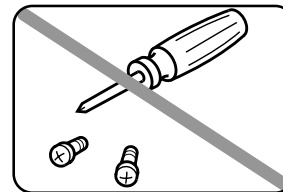

Never disassemble your fax machine!

Disassembling your fax machine can cause serious injury to you and damage to your fax. If service is required, call your authorized Muratec dealer.

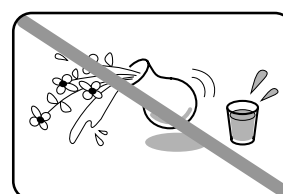

Keep away from liquids

Keep liquids and metal pins or other objects away from your fax machine. If something falls into the fax machine, remove the plug from the outlet, and call your authorized Muratec dealer.

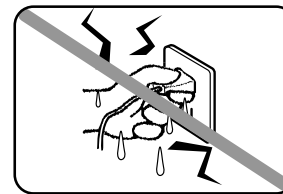

Never handle your fax machine or power cord with wet hands

Never touch your fax machine or power cord if your hands are wet.

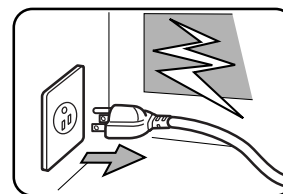

During electrical storms, disconnect the plug from the outlet

Electrical storms can cause electrical shock or damage to the fax machine.

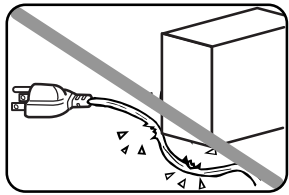

Do not put furniture or equipment on the power cord

Do not put anything on or over the electrical power cord, and do not route the power cord under rugs or carpets. Doing so can damage the power cord or fax, and can cause fire or electrical shock.

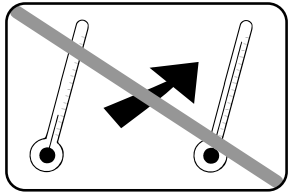

Avoid temperature fluctuations

Sudden changes in temperature can cause damaging condensation to form inside your fax machine.

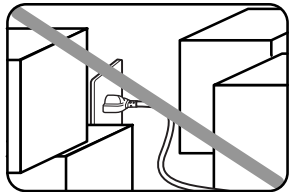

Allow clearance around the outlet

Don't stack boxes or furniture around the outlet.

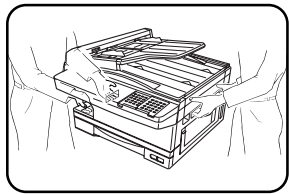

Use caution when carrying the fax

Lift and carry the fax machine as described in your operating instructions. Some fax machines require two people to safely and properly carry.

Use supplies manufactured specifically for Muratec fax machines

Using toner cartridges and other supplies that are not manufactured specifically for Muratec machines may affect the operation of your unit.

Storing and handling toner cartridges

To avoid damage to your fax machine and to assure the best performance possible, follow these guidelines when storing and handling toner cartridges:

Store the cartridge

Store toner cartridge at a constant temperature within a range of 50° F to 89.6° F (10° C to 32° C). Do not store cartridges in locations subject to extreme fluctuation of temperature and humidity.

Do not stand the cartridge on its end and do not store it upside down.

Do not open the protective bag of the cartridge until you are ready to install the cartridge.

Do not store cartridges in areas of:

- Direct sunlight
- Dusty conditions
- Near floppy disks or other computer media, computer screens, or any other materials sensitive to magnetic fields.

Do not burn toner cartridges!

The toner powder is extremely flammable. Exposure to flame can cause toner cartridges to burn or explode, causing serious injury.

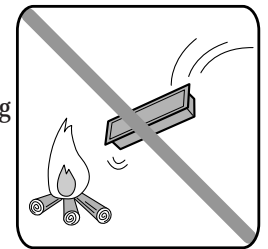

Be careful not to get the toner powder in your eyes.

If the toner powder gets in your eyes, wash your eyes well and see a doctor.

Keep cartridges away from water or oil.

Do not expose cartridges to direct sunlight.

Do not expose toner cartridges to static or other electrical shock.

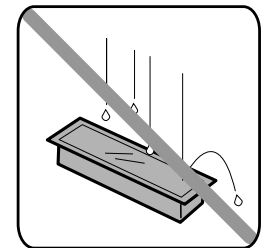

This page intentionally blank.

Welcome to your Muratec fax machine!

These instructions are divided into three sections.

- **“Getting started”** (page 1.1) covers only what you *must* know to use your machine immediately.
- **“Beyond the basics”** (page 2.1) provides more details. When you have time, look through it to learn more about your machine’s many features.
- Finally, **“Just in case ... ”** (page 3.1) helps you if you ever have a problem with your machine. It also tells you how to give your machine the kind of easy, sensible care that should keep troubles to a minimum.

Thanks for choosing Muratec.

Find your serial number and write it down

Please note that your machine’s *serial number* is located on the *bar code label* as shown on the drawing at right. Use the blank at the bottom of this column to copy this down *before* you set up your machine.

Note: The *IC label* and *ID label* label *do not* contain serial number information.

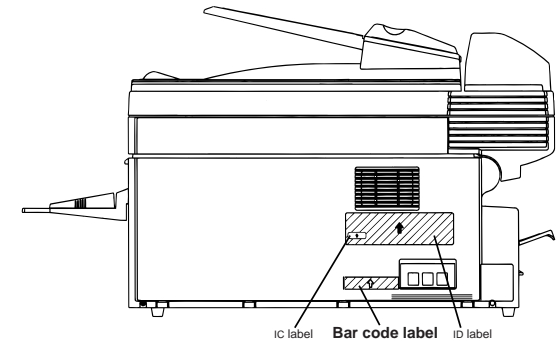

Close up, the bar code label looks something like this, but with a different set of numbers:



Please copy down your machine’s serial number below for future reference, and note the machine’s model number:

My machine’s serial number: _____

My machine’s model number: Muratec MFX-1500E

Table of Contents

Getting started	
A quick introduction to fax	1.1
Packaging contents	1.2
Parts of the Fax	1.2
The keys and their functions	1.4
Operating tips	1.6
Setting up	1.7
Pick an installation spot	1.7
Power tips	1.7
Removing the transport screws	1.7
Installing the printing supplies	1.8
Attach the paper-handling parts	1.9
Loading paper	1.10
Plug in and power up	1.12
Turn off the transport mode	1.12
Adjust the monitor speaker's volume	1.13
Attaching an optional handset	1.13
Attaching a second phone	1.14
EasyStart	1.15
Getting started	1.15
Clearing stored settings	1.15
Entering initial settings	1.15
Sending faxes	1.17
Guidelines	1.17
Sending a fax using the ADF	1.19
Sending a fax using the FBS	1.20
Sending a fax using monitor/call or a handset	1.21
Redialing	1.22
Review Commands, an introduction	1.23
Receiving faxes	1.24
Reception modes	1.24
Tel Ready mode	1.24
Fax Ready mode	1.25
Fax/Tel Ready mode	1.25
Tel/Fax Ready mode	1.26
Ans/Fax Ready mode	1.26
If the paper runs out	1.27
Making copies	1.28
Making copy settings	1.28
How to copy	1.29
Setting of enlargement or reduction for copying	1.31
Copy protection	1.31
Using your fax machine as a phone	1.32
Redial	1.32
Dialing with the monitor speaker	1.32
EasyDial directory dialing	1.32
Checking the fax reception mode	1.32
Dialing in the event of a power failure	1.32
Beyond the basics	
Entering settings for your fax machine	2.1
Scan settings	2.1
Using code to enter characters	2.2
Print settings	2.2
Image Rotation	2.3
Setting the number of rings	2.4
Setting ecm	2.4
Setting silent mode	2.4
Setting the confirmation stamp	2.5
Language settings	2.6
Printing your settings	2.6
Printing a program list	2.6
Autodialer	2.7
Autodialer basics	2.7
Call groups	2.8
Using one-touch numbers	2.8
Using speed-dial numbers	2.11
Printing a call group directory	2.14
EasyDial directory dialing	2.15
Broadcasting	2.16
Broadcasting basics	2.16
Delayed broadcasting	2.16
Making changes to broadcasts	2.16
Delayed transmission	2.17
Setting up a delayed transmission	2.17
Reviewing or canceling delayed commands	2.18
Printing a delayed command list	2.19
Printing a stored document	2.19

Batch transmission	2.20	Masking the PIN	2.57
Creating or modifying a batch box	2.20	Setting security transmission	2.59
Printing a list of batch boxes	2.21	Setting for use with a closed network	2.60
Storing a document for batch transmission	2.21	Setting Block Junk Fax	2.60
Printing a list of stored batch documents	2.21	Using department codes	2.62
Printing a document stored in a batch box	2.22		
Erasing a document stored in a batch box	2.22	Just in case ...	
Erasing an empty batch box	2.23	Clearing paper jams	3.1
Special features	2.24	If an original document jams	3.1
Soft Keys	2.24	Print quality problems	3.4
Macros	2.25	Troubleshooting	3.6
Cover page	2.28	Alarm	3.6
Setting the activity journal	2.29	LCD error messages	3.6
Setting the reports: TCRS and RCRS	2.30	Errors	3.9
Quick Memory transmission	2.31	Caring for your fax machine	3.12
Polling	2.31	Cleaning tips	3.12
OneLine + distinctive ring detection	2.33	Corrective cleaning	3.12
Call request	2.34	Cleaning the FBS	3.13
Numbering pages	2.35	If you have unsatisfactory printout quality	3.13
Transferring documents (Fax Forward)	2.35	Cleaning the LED print head	3.13
The power of QuadAccess®	2.37	Storing the toner and drum cartridge(s)	3.13
F-Code communication	2.38	Common questions	3.14
F-Code: an introduction	2.38	General questions	3.14
Creating or modifying an F-Code box	2.38	Sending faxes	3.14
Printing a list of F-Code boxes	2.42	We're here to help you!	3.14
Printing a list of documents stored in your F-Code boxes	2.42	Reports	3.15
Using a bulletin box	2.42	Receiving faxes	3.16
Using a security box	2.44	Working with your answering machine	3.16
Using a relay box	2.45	Polling	3.16
Erasing an empty F-Code box	2.45	How your fax machine works	3.16
F-Code transmission and polling	2.46	Glossary	3.17
Programmable one-touch keys	2.48	Specifications	AI.1
Using the power of programmable one-touch keys	2.48	Regulatory information	AI.3
Programming a delayed transmission	2.48	Limited warranty	AI.4
Programming a broadcast / group	2.49	Index	AI.5
Programming regular polling	2.50		
Programming a batch transmission	2.51		
Programming an F-Code transmission	2.52		
Programming F-Code polling	2.53		
Fax dialing with programmable one-touch	2.54		
Erasing a programmable one-touch key	2.54		
Printing a list of your programmable one-touch keys	2.55		
Security features	2.56		
The passcode	2.56		
Security reception	2.56		

Getting started

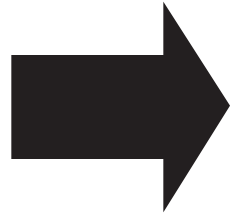

*A quick trip
through the basics
of your Muratec fax machine*

A quick introduction to fax	1.1
Packaging contents	1.2
Parts of the Fax	1.2
The keys and their functions	1.4
Setting up	1.7
EasyStart	1.15
Sending faxes	1.17
Receiving faxes	1.24
Making copies	1.28
Using your fax machine as a phone	1.32

A quick introduction to fax

What's a fax document?

A *fax document* is anything a fax user wants to fax to someone else. It can be one or more pages, and it can be text, a drawing or even a copy of a photograph.

What's a fax number?

Because your fax operates on standard phone lines, a *fax number* is just a regular phone number. And because your fax is also a high-quality, full-featured telephone, your fax number can be your regular phone number.

What are resolution and grayscale?

Just as cars are measured by engine size, fax machines are measured by *resolution* and *grayscale*.

Resolution refers to the sharpness of a fax transmission. It's expressed in *lines per inch (lpi)*. There are at least three levels of resolution for most fax machines:

- *Normal* (203 horizontal × 98 vertical lpi)
- *Fine* (203 × 196 lpi)
- *Superfine* (406 × 392 lpi).

Grayscale levels, or shades of gray — refers to the many shades of gray your fax machine sees on a document it's sending. It's likely most of your fax documents will be dark text on white paper. However, when you want to send photographs and other shaded items, you can send your fax documents with 256-level grayscale.

Why not always set your fax machine for superfine, or for grayscale?

Setting your fax machine for superfine resolution and grayscale mode makes your machine send more information, making transmissions last longer and potentially driving up your phone bills on long-distance calls. You'll find that we've made it easy for you to set your fax machine for the most efficient and truest transmission for the types of documents you send.

Packaging contents

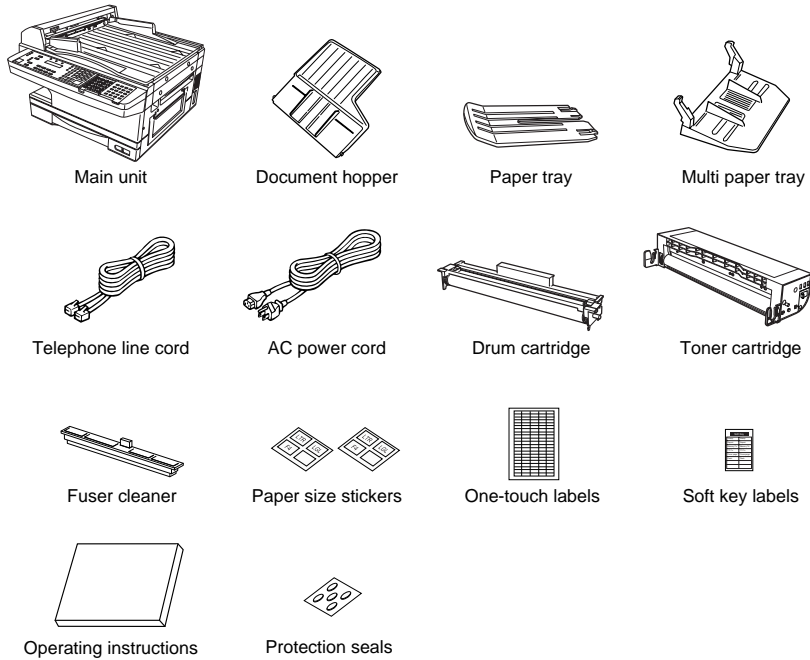

Included in your machine's packaging:

- Main unit with 400-sheet paper cassette installed
- Document hopper
- Paper tray
- Multi paper tray
- Telephone line cord
- AC power cord
- Drum cartridge
- Toner cartridge
- Fuser cleaner
- Paper size stickers
- One-touch labels
- Soft Key labels
- Operating instructions
- Protection seals (This seal may actually be used when your authorized dealer installs your fax machine.)

Note: Be sure to save the box (or boxes) and packing materials for reshipment.

Parts of the Fax

Note: Any terms used here that are unclear to you right now will be explained in detail in the coming pages.

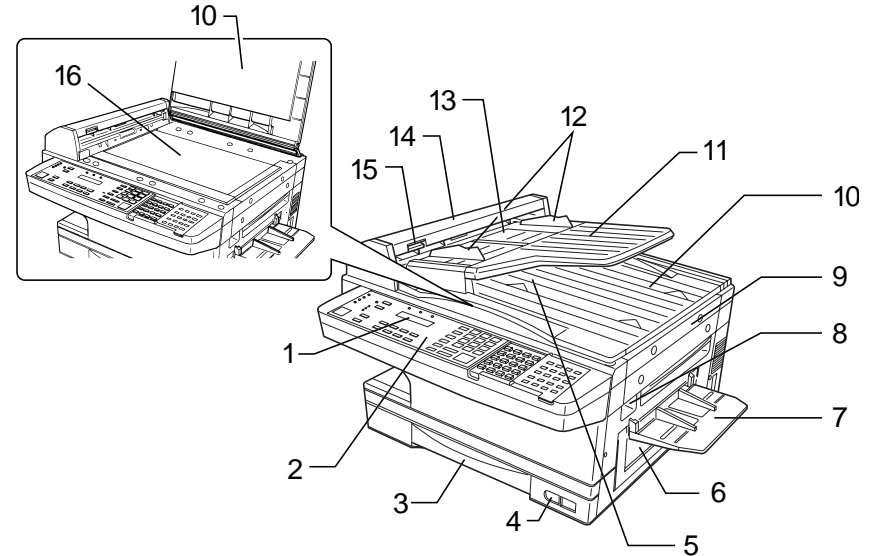

- 1 Liquid crystal display (LCD)** — Shows the machine's status and lets you see what you're programming into the machine. The display shows 2 lines, 20 characters per line. If the LCD is blank, the machine is off.
- 2 Control Panel** — The keys you use to operate your fax machine. (See pages 1.4–1.6 for more details.)
- 3 Paper cassette** — One of two locations where you put the recording paper (the Multi paper tray is the other). Holds up to 400 sheets, either letter or legal-sized paper.
- 4 Recording paper level indicator** — Shows the level of the current paper supply without requiring you to open the paper cassette.
- 5 Original document exit** — Where your original document comes out after being scanned.

- 6 Side cover** — Open to fix a printout jam.
- 7 Multi paper tray** — One of two locations where you put the recording paper (the paper cassette is the other). Holds only one sheet, either letter, legal or half-letter size paper.
- 8 Top cover release** — Pull up on this to open the top cover.
- 9 Top cover** — Opens to provide access for changing the toner and drum cartridge (or, occasionally, fixing printout jams).
- 10 Book-cover** — Opens to scan an original document using the flatbed scanner (FBS).
- 11 Document tray** — Holds original documents placed for scanning into the machine for faxing/copying.
- 12 Document guides** — Adjust these to fit the width of the original document so it will feed properly into the machine.
- 13 Automatic document feeder (ADF)** — The slot into which you place your original document for faxing or copying. It holds up to 50 sheets of letter-sized paper, 25 pages of legal-sized paper or 15 pages of 11" × 17" (ledger or tabloid)-sized paper.
- 14 Scanner cover** — Opens this by using the scanner cover release to remove original document paper jams.
- 15 Scanner cover release** — Pull up on this to open the scanner cover.
- 16 Flatbed scanner (FBS)** — Makes it possible for you to fax or copy objects and even irregularly shaped sheets, just as on a conventional copier.

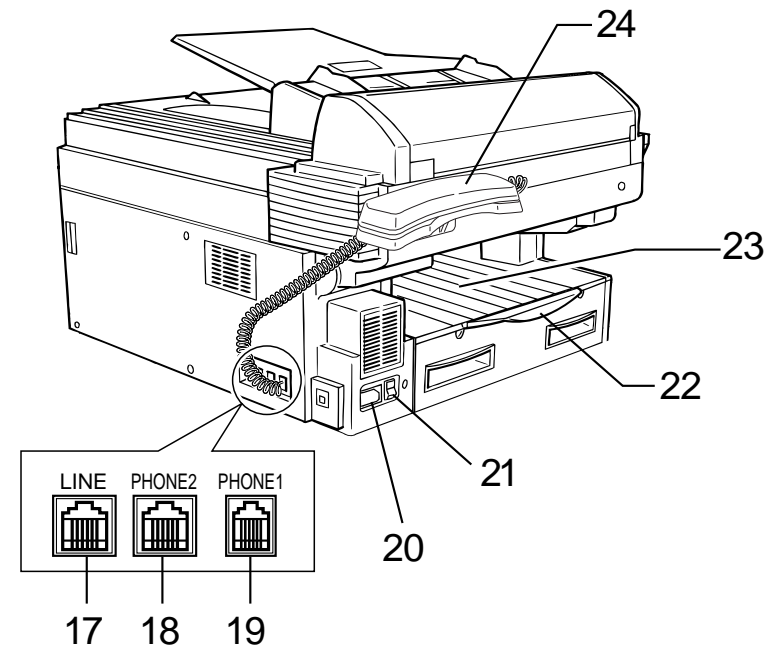

- 17 LINE jack** — Where you plug in the telephone line cord. The other end of the cord plugs into a wall telephone jack.
- 18 PHONE2 jack** — If you connect a second telephone to your machine, this is where you plug in the cord.
- 19 PHONE1 jack** — Where you plug in the optional handset.
- 20 AC power jack** — Where you plug in the ac power cord.
- 21 AC power switch** — Turns your fax machine on and off.
- 22 Paper tray** — Holds up the printout after it emerges.
- 23 Printed document exit** — Where the printout emerges.
- 24 Optional handset** — Used for voice communication. This handset is available from your authorized Muratec dealer, and can be added when you purchase the MFX-1500E or as an upgrade afterward.

The keys and their functions

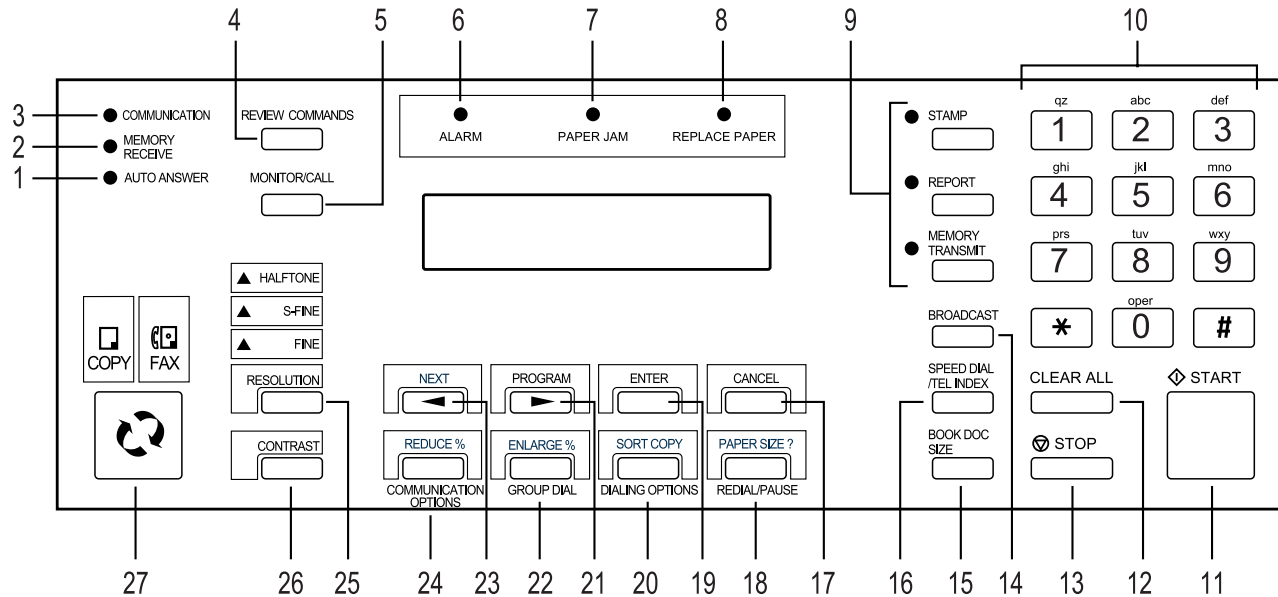

Important: Some of the functions mentioned here are covered in the “Beyond the basics” section.

- 1 AUTO ANSWER light** — Glows when auto-answer mode is active. In this mode, the machine answers automatically as a fax machine.
- 2 MEMORY RECEIVE light** — Glows when the machine is receiving an incoming fax document into its electronic *memory*.
- 3 COMMUNICATION light** — Glows when the fax machine is communicating with another machine.
- 4 REVIEW COMMANDS** — Press to review pending fax commands or to view a brief description of delayed commands.
- 5 MONITOR/CALL** — Turns the *monitor speaker* off or on. When it's on, it allows you to hear the call you're making. When using this feature, you can only hear the communication taking place. You cannot be heard unless you use a handset (optional). When sending a fax, this key also activates the *call request* feature.
- 6 ALARM light** — Glows when a problem occurs during fax communication, printing or scanning. The light stays on until the machine prints a *Check Message* report.

7 PAPER JAM light — Glows when a printed page jams in your fax machine.

8 REPLACE PAPER light — Glows when the paper cassette is empty. See pages 1.10–1.11 for details on replacing paper.

9 Soft Keys — Shortcut keys. Any function that can be turned on or off can be programmed into these three keys. If the light above one of these keys glows, this indicates the setting that's been programmed into it (see page 2.24) is turned on. These keys are programmed at the factory to turn the following functions on or off:

Soft key 1: **STAMP** — Press this key to set the machine to *stamp* each original document or page automatically when the machine scans it successfully.

Soft key 2: **REPORT** — Press to turn the confirmation report feature on or off for the next fax transmission.

Soft key 3: **MEMORY TRANSMISSION** — Selects which transmission mode your fax machine uses, whether from memory or from the document feeder.

10 Numeric keypad — Just like the numeric keys on a regular tone-dialing phone. Use these to dial phone and fax numbers and to enter numbers when you're setting up the machine.

- 11** **START** — Press to begin a fax transmission or reception.
- 12** **CLEAR ALL** — Resets copying settings to their defaults.
- 13** **STOP** — An all-purpose “Whoa!” key. Stops the current operation and ejects a document from the document feeder.
- 14** **BROADCAST** — Press to send a broadcast fax (sending the same document to more than one location).
- 15** **BOOK DOC SIZE** — Instructs the fax to scan either letter- or legal-sized documents when you use the flatbed scanner.
- 16** **SPEED DIAL/TEL INDEX** — Starts a *speed-dialing* operation, which you finish by pushing three of the keys on the *numeric keypad*. Also displays *one-touch* and *speed-dial* entries sorted alphanumerically, as in a telephone directory.
- 17** **CANCEL** — Press to delete characters on the LCD and cancel commands you have entered into the machine.
- 18** *In Fax mode:*
REDIAL/PAUSE — Redials the last number you dialed. In certain operations, it also produces a special *pause* character which can be useful when dialing long-distance numbers.
Or, in Copy mode:
PAPER SIZE? — Selects the printout paper you want to use.
- 19** **ENTER** — Much as **STOP** is a “Whoa!” key, **ENTER** is a “Go!” key. It confirms user settings, begins operations and moves through command levels.
- 20** *In Fax mode:*
DIALING OPTIONS — Press this to insert special symbols into telephone numbers (see page 2.7).
Or, in Copy mode:
SORT COPY — Press this key to toggle the sorting of printed copies.
- 21** *In Fax mode:*
►/PROGRAM — Scrolls (moves) through features and command options as displayed on the LCD.
Or, in Copy mode:
 Press ► to increase the reduction or enlargement rate at 1% intervals.
- 22** *In Fax mode:*
GROUP DIAL — Press this to set up a fax transmission to a *call group*, a set of fax numbers which will receive the same document in one fax operation.
Or, in Copy mode:
ENLARGE% — Press this key to choose one of several fixed copy enlargement rates. (See page 1.31 for more information.)
- 23** *In Fax mode:*
◀ — Scrolls (moves) through features and command options as displayed on the LCD.
Or, in Copy mode:
 Press ◀ to decrease the reduction or enlargement rate at 1% interval.
While scanning a document:
NEXT — Press to tell your machine to scan one or more additional documents after the current scanning ends.
- 24** *In Fax mode:*
COMMUNICATION OPTIONS — Chooses from among several fax options: delayed transmission, SecureMail transmission, relay broadcast, polling, batch transmission or F-Code communication.
Or, in Copy mode:
REDUCE% — Press this key to choose one of several preset copy reduction rates. (See page 1.31 for more information.)
- 25** **RESOLUTION** — Press to toggle among the three resolution modes and grayscale.
- 26** **CONTRAST** — Press to enter the contrast setting mode. To change the contrast level, press ◀ or ► keys.
- 27** **COPY/FAX** — Press this key to toggle between Fax mode or Copy mode.

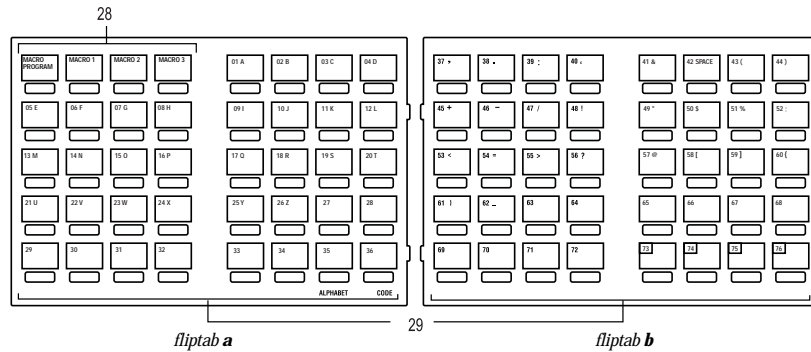

28 Macro Keys — Programming the Macro keys (MACRO 1 – MACRO 3) can reduce many steps of the operation to a simple press of a key. You can “teach” the Macro keys to carry out one of the several operations (see pages 2.25–2.27).

29 One-Touch Keys — The keys labeled **01-36** (or **37-72**, if you’re using fliptab B) offer one-touch dialing convenience. You also can use the keys labeled **73-76**, if you’re using fliptab B, for programmable functions: this lets you teach your machine an advanced multi-step function just once, then recall the function at any time by pressing one of these keys.

Operating tips

To press: 0 (zero), 1, 2, 3, 4, 5, 6, 7, 8, 9, # or *

Use: The numeric keypad.

Tip: *At no other time within this manual will we refer to the letters printed below the numeric keys and their uses (such as accessing abc by pressing the 2 key.) These letters are there only for your convenience in using your fax machine as a telephone.*

To press: A, B, C, D or any other letter key

Use: The one-touch key labeled with that letter.

Tip: Please don’t confuse the zero (0) with the letter o.

Here’s an example. If we say “press ►/PROGRAM, 7, ENTER, 0, 8, ENTER” ...

```

... you’d press ►/PROGRAM
... then 7
... then ENTER
... then 0 (the numeric key zero)
... then 8
... and then ENTER
    
```

Important: Even though our example above includes commas, do not enter them into the fax machine. Those characters appear in our instructions to separate one number from the other. They do *not* need to be entered into your fax machine.

There is a function (broadcasting) which requires commas to be entered, but there is a special way to enter them. We’ll explain this process later.

Setting up

Pick an installation spot

Where should you install your fax machine? The location should be:

- **Clean** — Dust buildup can damage your machine. (However, do not use a cover!)
- **In the open** — Allow at least 12 inches of clearance around your machine. Be sure that you never cover the machine. Its vents must be able to “breathe.”
- **Away from direct sunlight** — This helps avoid overheating.
- **Dry** — Avoid any location where splatters or sprays (such as from a water fountain) could reach your fax machine.
- **Level, and vibration-free.**
- **Near a phone jack** — Your fax machine uses a standard (modular) telephone jack, also known as an RJ-11.
- **Near an ac power outlet** — The ac power cord is about 5 feet long when stretched to its limit, and the power cord should never be stretched to its limit.

Power tips

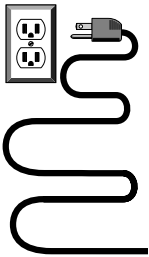

- **Use a standard three-pronged 120 VAC outlet.**
- **Make sure the outlet isn't controlled by a wall switch.** If it is, you'll risk occasional shutoffs to the machine, causing you to lose fax messages.
- **Don't use an outlet which also is supplying power to a large appliance,** such as a refrigerator or air conditioner. Such high-consumption appliances can cause “draw-downs” (temporary drops in the power available for other equipment on the circuit) which could damage your fax machine.
- **Use an electrical surge suppressor,** preferably one which guards both telephone and electrical lines. This device helps to shield your fax machine from damaging high-voltage electrical surges.

Voltage requirements: 120 VAC ± 10%, 50–60% Hz.

Power consumption:

	Standby	Transmission	Reception	Copying	Maximum*
	19 w	51 w	830 w	840 w	1180 w

* ; simultaneous copying, communicating and scanning

Removing the transport screws

Your fax machine is shipped with transport screws for protecting your fax machine's mirror carriage during shipping.

Important: Be sure that you do not turn the power on until after you have removed the transport screws. Otherwise, damage could result.

- 1 Remove the four transport screws, as shown.

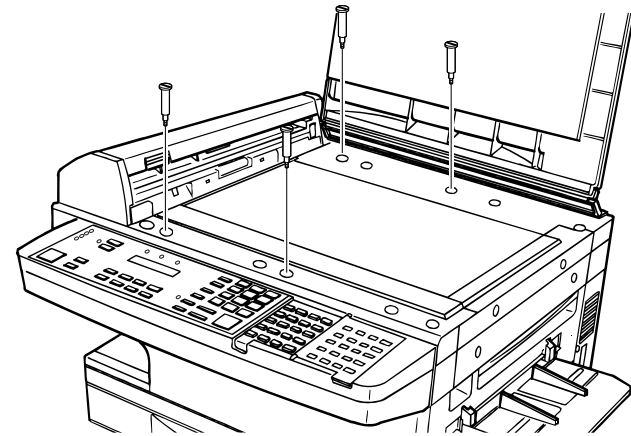

- 2 Get the protection seals from your manual kit, and attach one protection seal on each transport screw's now-open hole. This shields the hole while you are using the machine.

IMPORTANT: BEFORE YOU USE THE MACHINE, YOU MUST TURN OFF THE TRANSPORT MODE (see page 1.12).

Note: Be sure to save the screws for reshipment. If you must ship your machine for some reason, turn on the transport mode, turn the power off and then undo the above procedure as follows:

- Remove the seals (reversing step 2);
- Reinstall the screws (reversing step 1).

Installing the printing supplies

Your fax prints incoming faxes and copies with a reliable 400 dpi print engine. Your fax requires two types of printing supplies (sometimes also called consumables):

- The *drum cartridge* — It yields 20,000 normal letter-sized printouts (see “Specifications,” page AI.1). By “normal,” we’re referring to the amount of text and/or graphics on each page. This is based on an industry-standard test document.
- The *toner cartridge* — It yields 10,000 “normal”, letter-sized printouts (see “Specifications,” page AI.1).

To install these supplies:

- 1** Pull up the *top cover release* and open the top cover.

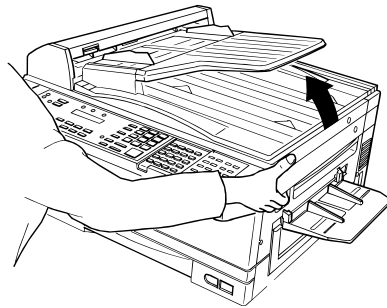

- 2** Pull up the *printer cover release* and open the printer cover.

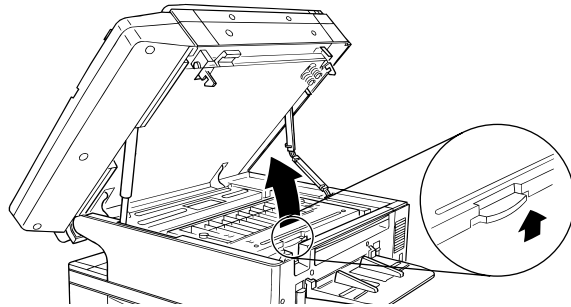

- 3** Unpack a new toner cartridge from its carton. Then, holding the toner cartridge with both hands, slowly shake it as shown (note the arrows).

Note: Do not throw the toner cartridge into the fire; this will avoid any possibility of ignition and/or injury.

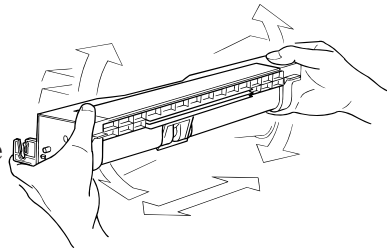

- 4** Place the new toner cartridge on a flat, clean surface.

- 5** Unpack the drum cartridge from its carton.

Note: Shield the drum cartridge from light, especially strong light. Later, if you have to remove the cartridge from the fax, immediately wrap it in a thick cloth to protect it from light.

- 6** Set the drum cartridge on the toner cartridge, making sure that the drum cartridge's two pins fit in the slits inside the toner cartridge frame.

Note: Do not touch the developing roller.

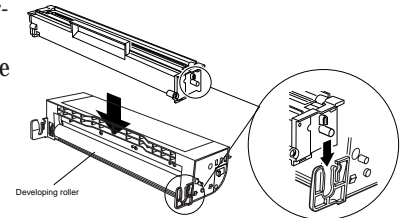

- 7** Grip toner cartridge as shown, to avoid pinching your fingers between the toner cartridge and the printer frame. Keep the drum slot free of dust and other foreign materials.

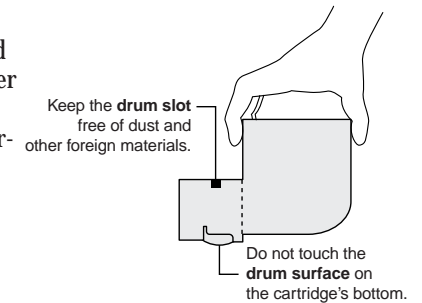

- 8** Gently install the toner cartridge in the printer, making sure the toner cartridge's four pins fit in the slits inside the printer frame.

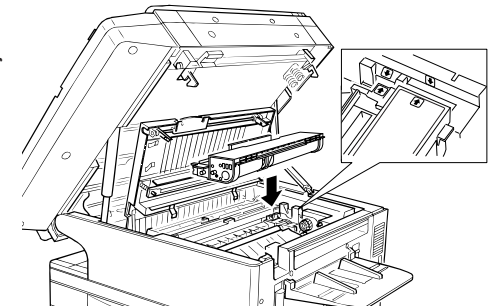

- 9** Insert the fuser cleaner into the slot in the fuser unit. The fuser cleaner cleans the fuser unit roller.

You should replace the fuser cleaner every time you change the new toner cartridge.

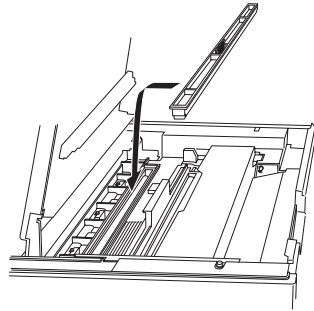

- 10** Gently clean the LED print head using the cleaning paper.

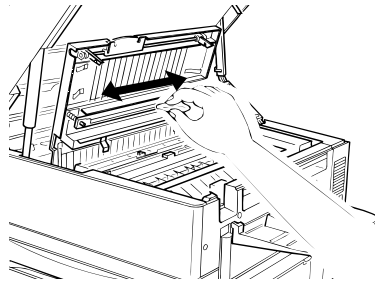

- 11** Close the printer cover.

- 12** Close the top cover. Be sure to push on a portion of the cover to lock it into its original (closed) position.

Note: The fax machine will not work if the cover isn't closed properly.

Attach the paper-handling parts

- 1** Attach the document tray by inserting it into the appropriate holes, as shown.

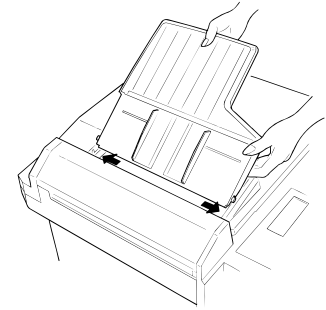

- 2** Attach the Multi paper tray by inserting its two pegs at a slightly upward angle into the appropriate holes, as shown.

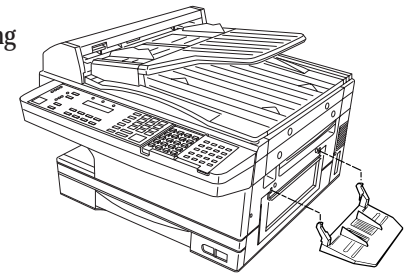

- 3** Attach the paper tray by inserting its two pegs at a slightly upward angle into the appropriate holes, as shown.

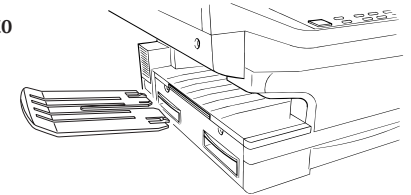

Loading paper

Your machine's standard paper cassette can hold up to 400 sheets at a time. Each optional cassette, available from your Muratec dealer at the time of purchase or as an upgrade, can hold an extra 200 sheets. In addition to boosting your total paper supply, adding an extra paper cassette allows your fax machine to use two types of paper, letter and legal, for example, at the same time.

Loading the paper cassette

Before you load paper, note the following:

- The paper cassette can be adjusted to accept letter- or legal-sized paper.
- Before you load the cassette, you will need to "tell" your fax machine which size of paper, letter- or legal-sized, you will be loading. You can do this by setting a pin located on the rear side of the paper cassette.

Note: If you will be using letter-sized paper, there's no need to adjust the cassette; your fax is initially set for this paper size. Simply attach the LTR sticker to the outside of the paper cassette.

- 1 Pull the paper cassette completely out of your fax.

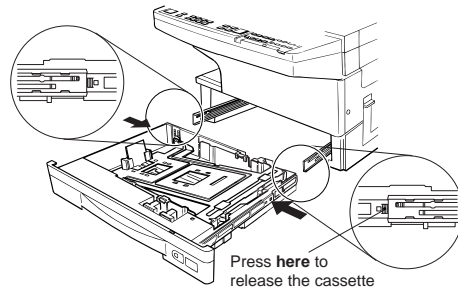

- 2 On the rear side of the cassette, you will see the pin and three sets of holes. Note the drawing below. If the pin is in the upper and lower set of holes, your fax "thinks" the cassette holds letter-sized paper. If the pin is in the middle and lower holes, your fax thinks the cassette has legal-sized paper.

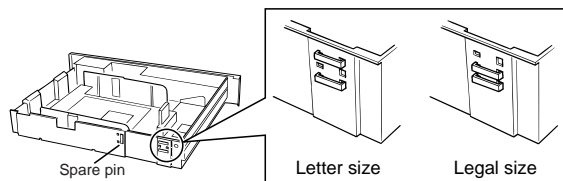

Setting for legal-sized paper

Your fax comes set for letter-sized paper. To set it to use legal-sized paper:

- 1 Unlock the pin from the upper set of holes by reaching inside of the paper cassette and pressing the nib, as shown.

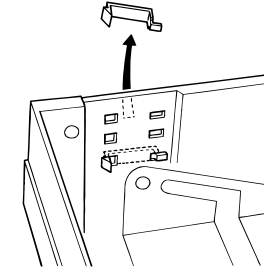

- 2 Remove the pin.

- 3 Insert the pin into the middle set of holes. You will hear a click when it is locked into place.

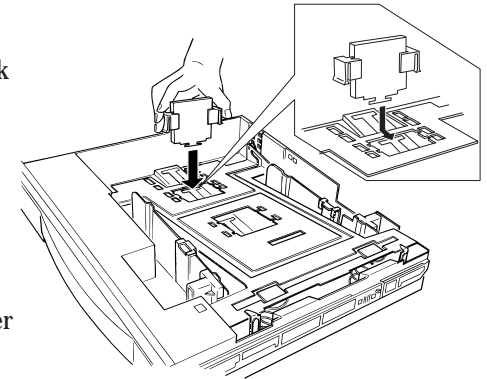

- 4 Install the paper guide into the holes corresponding to the paper size you are installing.

Important: Remember, you've now told your fax that the paper cassette holds legal-sized paper. If you now try to use letter-sized paper without returning the pin to the upper holes (the setting for letter-sized), your fax will sound an alarm tone and display the following message when you try to print:

**Check Rx Paper Size
Open&Close Top Cover**

- 5 Be sure to attach the LGL sticker to the outside of the cassette to remind you which paper size it contains.

Installing paper

- 1 Open the paper cassette from the front of your fax by gently pulling it toward you.

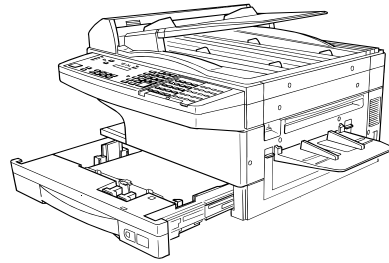

- 2 Insert the paper into the cassette.

Note: Before you insert paper in the cassette, stack it so the leading edge and sides of the paper are even.

- Make sure the stack of paper isn't higher than the limit mark on the side of the cassette.
- Place the edges of the top sheet under the metal tabs on the cassette's left and right side (as viewed from its front, as shown).
- The paper cassette can hold about 400 sheets of paper.

Note: Each of the two optional additional cassettes can hold about 200 sheets of paper. Thus, you can have as many as 800 sheets of paper "on-line." For more details on these and other options for your fax machine, please contact your authorized Muratec dealer.

- 3 Check the front corners of the paper stack and make sure they are below the tabs.

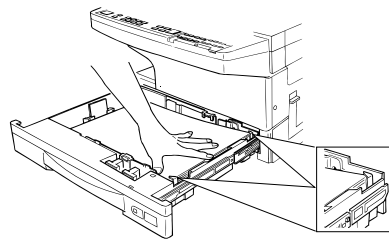

- 4 Push the paper cassette back into its original (closed) position. You'll feel a click when it's properly in place.

- 5 Attach the paper size sticker on the cassette's front.

Paper level indicator

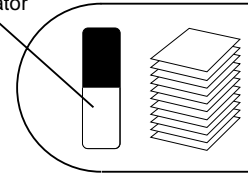

The paper level indicator on the front paper cassette lets you see how much paper is in the cassette without your having to open the cassette. When you see the paper level indicator drop (i. e., show more dark area), make sure you have a supply of paper nearby. Then, when you see the "Please Supply Paper" message on the display, you'll be ready to refill the cassette.

Important: To avoid paper jams, do not refill this tray without first removing all of any paper which may remain in it. In other words, do not just add sheets to an already-loaded stack.

Loading the multi paper tray for copying

You may use letter-, legal- and half-letter sized paper in the multi paper tray, which the machine uses for copying only, not for faxing.

Important: If loading transparency (OHP) film into the multi paper tray, be sure that the sheet is designed for laser printers and not for copiers. Also, be sure that the film does not have a paper backing and/or a leading strip. If it does, remove the paper backing and/or strip before inserting. Only film should go in, not film with any backing or strip.

- 1 Adjust the multi paper tray for the width of paper you plan to load, by sliding the guide to the slot for the paper size you'll be loading.
- 2 Insert a sheet into the multi paper tray until it won't go in any farther.

Note: The multi-purpose tray can hold only one sheet of paper at a time.

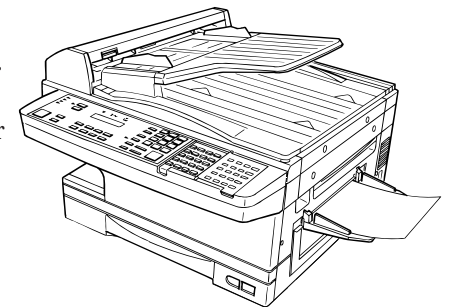

Plug in and power up

Important: Be sure you do not turn the power on until after you remove the transport screws. (See “Removing the transport screws,” page 1.7.)

- 1 Plug one end of the telephone line cord into the **LINE** jack on the machine's rear side. Plug the other end of the cord into a standard telephone wall jack, just as you would plug in a phone.

Note: If you have purchased an optional handset, do not confuse its curled handset cord with the uncurled telephone line cord.

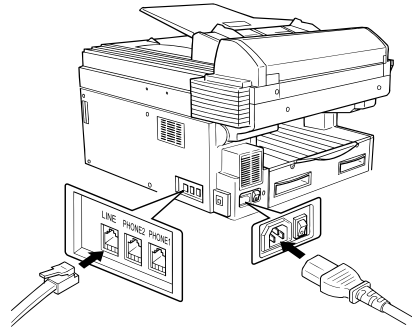

- 2 Plug the non-pronged end of the AC power cord into the AC power cord jack on the left side of the machine.
- 3 Plug the pronged end of the AC power cord into a 120 V electrical outlet (preferably on a surge suppressor, as mentioned on page 1.7).

Important: Be sure that you do not turn the power on (next step) until after you have removed the transport screws (see page 1.7).

- 4 Use the AC power switch to turn on your machine. The markings are international standards: I means on, O means off.

It will take a few seconds for the machine to warm up. The display will show:

** Please Wait **

When the machine is ready to use (standby mode), you will see either . . .

Fax Ready Jan 1 2000 0:00	or	Copy Ready Num: 1 < ▶ C1:Ltr 100%
-------------------------------------	----	--

Fax mode

Copy mode

If the machine beeps, its **ALARM** light glows and the display shows an error message, this means there is a problem of some sort. Please consult “Just in case...,” beginning on page 3.1.

Turn off the transport mode

Important: Be sure you do not turn the power on until after you remove the transport screws. (See “Removing the transport screws,” page 1.7.)

To turn off the transport mode:

- 1 Power up the machine.
If the machine is already in Fax mode, skip to step 3.
If the machine is in Copy mode, proceed to step 2.
- 2 Press **COPY/FAX** to switch the machine to Fax mode.
- 3 Press **PROGRAM, *, E**.
- 4 Select Off by pressing **PROGRAM**. Then press **ENTER** to turn off the transport mode. The mirror carriage will move to the home position.

Mirror Locked :On Program/Enter

Mirror Locked :Off Program/Enter
--

Important: If you must reshipe the machine to any other location, turn on this mode to move the mirror carriage to the transport position (in step 4, above, press program to set the transport mode to On), then power off and mount the mirror carriage using the four transport screws.

Adjust the monitor speaker's volume

You can set the volume of the monitor speaker, assuring that on-hook dialing will be as loud (or as soft) as you require.

- 1 Press **MONITOR/CALL** on the control panel. You now should hear a dial tone, and the display will show:

** Tel Mode **

Important: If you don't hear a dial tone, make sure your fax machine is plugged into a working phone line.

- 2 If the volume you hear is satisfactory, skip to step 4. Otherwise, proceed to step 3.
- 3 Adjust the volume as you wish:
To turn the volume up, press **▶**.
To turn the volume down, press **◀**.
The LCD indicates the volume. Here are the possible settings:

** Tel Mode **
Volume: ■■■■■■

= Loudest setting.

** Tel Mode **
Volume: ■■■■

= Medium setting.

** Tel Mode **
Volume: ■■

= Low setting.

** Tel Mode **
Volume:

= Volume off.

- 4 Press **MONITOR/CALL** again to hang up.

Attaching an optional handset

You may purchase an optional handset for your fax machine. Here is how to attach the handset.

Important: Do not connect the handset directly to a telephone wall jack. Instead, connect it only to your fax, as these instructions describe.

- 1 Remove the two screw caps and screws.

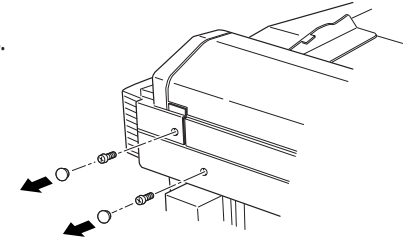

- 2 Using a Phillips-head screwdriver, attach the handset cradle to the rear side of your machine, using the screws included with the cradle.

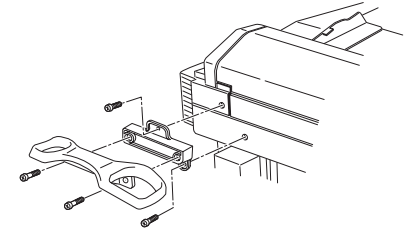

- 3 Plug one end of the handset cord (it's curled) into the **PHONE1** jack on the left of your machine.

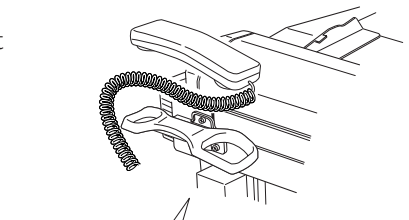

- 4 Plug the other end of the handset cord into the jack on the handset. If connected to a phone line, your fax machine is now "off-hook."

Note: The handset has a small "flash" button which you can press while holding the handset, putting the fax machine back "on-hook" until you can hang up the handset properly in step 5.

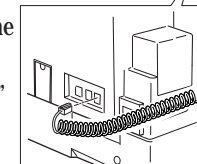

- 5 Place the telephone handset onto the handset cradle. The cradle will press the handset's "flash" button, hanging up the handset.

Attaching a second phone

Want to attach a second phone (even a cordless model!) to your fax machine, so they can share the same phone jack? No problem.

Before we go further, let's explain the idea. You're plugging the second phone's phone line into your fax machine's PHONE2 jack, not the wall phone jack. In such a setup, only your fax machine connects to the wall. The second phone receives phone signals through your fax machine.

Now, let's proceed...

- 1 If your second phone is already plugged into a wall phone jack, disconnect it from that jack, at the jack. Hold onto the phone plug; you'll need it in step 2.

Note: Of course, if your second phone is a model which also requires AC power, as is true for the base of a cordless phone, don't unplug it from its AC power jack!

- 2 Using the plug mentioned in step 1, plug the phone cable from your second phone into the **PHONE2** jack on the left side of your fax machine.

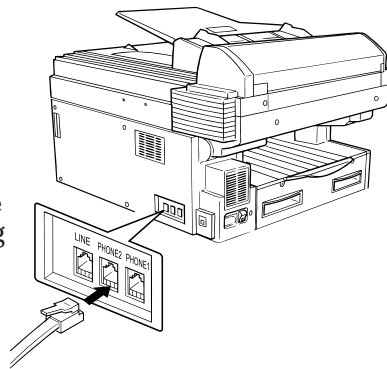

For information on how to use a connected second telephone with your fax machine, see "Receiving faxes," beginning on page 1.24.

Installation complete!

Now, see how our EasyStart feature will have you up and running within minutes.

EasyStart

EasyStart software is already installed on your Muratec fax machine. It guides you through the process of entering your machine's settings. Remember that the settings you make here can always be changed later. We'll explain more in "Beyond the basics," beginning on page 2.1.

Getting started

Determine the following before you go any further:

- 1 The type of dialing** your telephone system requires — Choose either *tone* or *pulse* (rotary) dialing.
- 2 The name and fax number you want to appear on your faxes** — Every fax page you send arrives at the receiving machine with a single line of text at the very top of the page. This text lists a *name*, called the *Transmit Terminal Identifier (TTI)*, and a *fax number*. The TTI cannot be longer than 22 characters.

Clearing stored settings

Before using EasyStart, clear your machine's built-in *user data memory*. This ensures the memory will hold only *your* settings.

Important: After you use EasyStart, *do not* clear the memory again unless an authorized technician asks you to do so.

To clear the machine's memory:

- 1** Press ►/PROGRAM, *, **2**. The LCD now asks if you want to clear the memory:

```
Clear User Settings
Check Program/Enter
```

Note: If you *don't* want to clear the memory, just press ►/PROGRAM.

- 2** If you *do* want to clear the memory, press ENTER.

Entering initial settings

Important: If you press STOP during EasyStart, your fax machine returns to *standby mode* (its normal condition). But it will keep the settings you saved by pressing ENTER as described in these instructions.

- 1** Press ►/PROGRAM, I, ENTER.
The LCD shows the current calendar/clock setting, with a *cursor* appearing under the first digit.

```
Enter Time
'01 01/01 00:00
```

- 2** Use the numeric keypad to enter the *correct date and time*, using a *YYMMDD* format for the *date* and *24-hour* ("military") format for the *time*. For instance, to set 8:30 PM on January 11, 2000, press **0001112030**, which results in:

```
Enter Time
'00 01/11 20:30
```

Note: Your fax machine automatically inserts the spaces and date-slash. All you have to do is enter the digits.

To change a digit, press ◀ to move the cursor left, or ►/PROGRAM to move it right. Then enter the correct digit.

- 3** Press ENTER to save the clock setting and continue EasyStart.
- 4** The LCD now asks if you want to set the calendar/clock to automatically recognize daylight saving time (DST).

```
Daylight Saving:Off
Program/Enter
```

When the setting is *On*, your machine automatically recognizes DST at 2 AM on the appropriate switchover Sundays each year.

When the setting is *Off*, no automatic change will occur.

Getting started

- 5** Press ◀ or ▶/PROGRAM until the mode you want appears. Here, we've changed the setting to *On*:

Daylight Saving:On
Program/Enter

- 6** Press ENTER to save the setting and continue.

- 7** The LCD now asks you to enter your fax number as you want it to appear on other fax machines' displays or printouts. The fax industry term for this number is *Subscriber ID*.

Your Fax Number
—

- 8** Use the numeric keypad to enter the fax number. To insert a dash, as shown here, press **DIALING OPTIONS** once. The number may contain up to 20 characters (numbers and dashes).

Your Fax Number
972-555-5525

Note: If you make a mistake, press **CANCEL** to erase to the left. To change just one number, press ◀ to move left, or ▶/PROGRAM to move right. Press **CANCEL** to erase the number. Then re-enter the fax number correctly.

- 9** Press ENTER to save the number.

- 10** The LCD now asks you to enter the name you want to appear at the top of faxes you send. The name may be up to 22 characters in length.

Use the one-touch keys to enter letters and other non-numeric characters.

Your Name ;Upper
—

The word "Upper" means the machine will enter only upper-case letters. If you press **R**, the machine will see it as an *R* (not an *r*).

To type a lower-case letter, press **ALPHABET**. The display changes to:

Your Name ;Lower
—

This means pressing one-touch keys will enter lower-case letters: pressing **R** will produce an *r* (not an *R*) on the display.

To switch back for upper-case entries, press **ALPHABET**.

To enter spaces, punctuation and symbols, use the one-touch keys.

In "Beyond the Basics," we'll show you how to use the **CODE** function to enter even more characters (see page 2.2).

Note: If you make a mistake, press **CANCEL** to erase to the left. To change just one character in the name, press ◀ to move left, or ▶/PROGRAM, to move right. Press **CANCEL** to erase the character. Then re-enter the character correctly.

- 11** Press ENTER to save the setting and continue.

- 12** The LCD now asks you to enter the type of dialing needed for the fax machine, either *tone* or *pulse*:

Phone Type :Tone
Program/Enter

- 13** Press ◀ or ▶/PROGRAM until the mode you want appears. Here, we've changed the setting to *Pulse* mode:

Phone Type :Pulse
Program/Enter

- 14** Press ENTER to save the setting and continue.

- 15** The LCD now shows the machine's current reception mode.

Fax Ready
Program/Enter

- 16** For now, press ◀ or ▶/PROGRAM until the setting *Fax Ready* appears. (This setting can always be changed. We'll discuss reception modes further on pages 1.24–1.27.)

- 17** Press ENTER to save the setting. Your machine will return to standby mode.

EasyStart is complete!

Sending faxes

Guidelines

Page sizes

While you'll probably send letter- and legal-sized documents most of the time, it's possible to fax a piece of paper as small as a notepad sheet or one nearly three feet long.

The acceptable dimensions (width × length) are:

Automatic document feeder (ADF)

SINGLE-SHEET	MULTIPLE-SHEET
Maximum: 12.0" × 35.4"	Maximum: 11.7" × 16.5"
Minimum: 4.7" × 3.9"	Minimum: 5.8" × 4.1"

Flatbed scanner (FBS)

Maximum: 10.1" × 14.3"

Things *not* to put in your fax

To avoid paper jams and damage to your machine, **don't insert:**

- Folded, curled, torn, wrinkled or very thin pages
- Documents with staples, glue, tape, paper clips or still-wet correction fluid
- "Sticky notes" (or documents with "sticky notes" attached)
- Cardboard, newspaper or fabric
- Pages with duplicating carbon on either side
- Credit cards or any small, thick items

Resolution, grayscale and contrast

Reviewing resolution and grayscale:

- **Normal resolution** ("NORM" on the control panel) is suitable for most typed documents and simple drawings.
- **Fine resolution** ("FINE" on the control panel) is ideal for maps, moderately complicated drawings, floorplans or handwritten documents.
- **Superfine resolution** ("S-FINE" on the control panel, "S Fine" on the LCD) reproduces the detail of extremely complicated drawings or line art.
- **Grayscale mode** ("HALFTONE" on the control panel; "Gray" on the LCD) captures shades in photos and drawings.

Note: If you send a fax in superfine, certain fax models (especially older, non-Muratec models) receive it only in fine mode. However, you can send a fax in grayscale mode to virtually *any* fax machine currently in use.

▶ HALFTONE To change the resolution setting, press **RESOLUTION** repeatedly. As noted above, if neither the FINE, S-FINE nor HALFTONE LED (light-emitting diode; in this case, a small green light) is glowing, your fax is set for normal resolution. Otherwise, a glowing LED indicates the fax is using the setting named by that LED. For example, in the drawing (left), the machine is set for FINE resolution.

▶ S-FINE
 -▶ FINE
 RESOLUTION

Contrast

Setting the contrast allows you to compensate for any excessive lightness or darkness, as the case may be, of document pages you are sending or copying.

To change the contrast setting:

- 1 Press **CONTRAST** on the control panel. The display, or LCD (liquid crystal display), indicates the current contrast setting.

Set Contrast
Light ◀ · · ■ · · ▶ Dark

- 2 To adjust the contrast setting, press ◀, ▶ or **CONTRAST**.
 To light up an overly dark document, press ▶.
 To darken an overly weak document, press ◀.

Getting started

Note: To avoid confusing the Light and Dark settings, just remember — “Light lightens” and “Dark darkens” — to keep it straight.

Entering a pause character when dialing

Some long-distance systems require dialing pauses, and pauses can also be useful when you’re dialing through special telephone exchanges.

To insert a *pause* character, just press **REDIAL/PAUSE** after you’ve dialed at least one other character. -/ (the pause character) will appear on the display.

Each pause entered lasts for a factory-set two seconds (see “Changing the pause length,” below, for instructions to change this setting).

For example, if the pause is at the factory setting, pressing **9, REDIAL/PAUSE, 19725552009** dials *9 [2-second pause] 1 9 7 2 5 5 5 2 0 0 9*.

Important: Each pause uses *two* of the characters you’re allowed in a number.

Changing the pause length

The pause is set by the factory to last two seconds, but you can set it to last as long as ten seconds if necessary. To change the pause length:

- 1 Press **PROGRAM, J, 0, 4, ENTER**.

```
Set Dialing Pause
Time      (02-10):02
```

- 2 Use the numeric keypad to enter the length you want for the dialing pause. Here, we’ve chosen nine seconds.

```
Set Dialing Pause
Time      (02-10):09
```

Note: The length setting requires two digits. Always enter a leading zero for lengths less than 10 seconds.

- 3 Press **ENTER** to save the setting.

Potential problems with call-waiting and voice mail

Telephone call-waiting signals can stop fax transmission and reception. And any service — such as voice mail — which may intercept your calls can keep your fax machine from receiving fax calls.

If you use only one line for both phone and fax, consult your telephone company to see how you can temporarily disable call-waiting or voice mail while using the fax machine.

Using memory transmission

Your fax machine has a great memory! Take advantage of it, and you could:

Save Time. By using your fax machine’s memory, you won’t have to wait for your machine while it completes the transmission. Simply scan your document into your fax machine’s memory, and you can walk away with your original in hand.

Save Money. If you’re transmitting to another memory-equipped fax machine, your machine will send the document directly into the other machine’s memory and hang up. (The receiving machine then prints out your message from *its* memory after the call has ended.) This cuts your actual on-line time to a minimum.

Save Even More Money. Set up a *delayed command* (see pages 2.17–2.19) to send your document after hours, and you can save more money, because the line charges will be cheaper.

You can set your fax to transmit from memory as the *default*.

Note: Whether you decide to send your documents from memory or manually, you can override that choice one transmission at a time by pressing **MEMORY TRANSMIT** before you send your document. After completing the communication, your fax will return to the *default* setting.

Note: Some documents use up memory more quickly than others. They include documents with many pages and those with many dark areas. *When the machine’s memory is full, it can transmit only through the document feeder.*

Note: When you use the flatbed scanner, the machine always uses memory transmission.

To make memory transmission the default:

- 1 Press **►/PROGRAM, J, 1, 3, ENTER**.

```
Memory Tx      :On
Program/Enter
```

- 2 Press **◀** or **►/PROGRAM** until the mode you want appears. In this example, we’ve chosen *Off*.

```
Memory Tx      :Off
Program/Enter
```

- 3 Press **ENTER** to save the setting.

If the **MEMORY TRANSMIT** light glows, memory transmission is *on*.

If the **MEMORY TRANSMIT** light doesn’t glow, memory transmission is *off*.

Sending a fax using the ADF

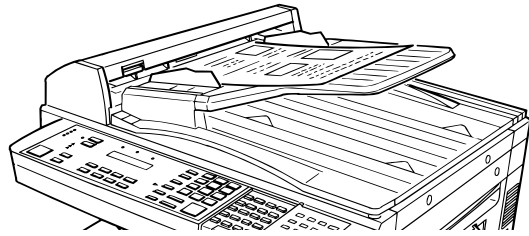

- 1 If the machine is already in Fax mode, skip to step 2.
If the machine is in Copy mode, press **COPY/FAX** to change to Fax mode.
- 2 Adjust the document guides — by sliding either of them to the left or right — to fit the page(s) you'll be faxing. Your fax machine's automatic document feeder will hold up to 50 pages of letter-sized paper, 25 pages of legal-sized paper or 15 pages of 11" × 17" (ledger)-sized paper.
- 3 Insert the document **face up**. When a document is in the feeder, the LCD shows the current scanning width (see "A4, B4, A3" in the Glossary beginning on page 3.17) and the amount of memory available:

```
Document Ready
A4           Mem100%
```

- 4 *Adjust resolution and contrast if necessary.*
Press **RESOLUTION** to change the resolution.
Press **CONTRAST** to change the contrast.
- 5 *Adjust memory transmission if necessary.*
Press **MEMORY TRANSMIT** to toggle memory transmission on and off.
- 6 *Enter the fax number.*
Also, enter any access codes necessary, just as you would for a regular phone call. (Example: Enter 9 to "dial out" from an office telephone system, or 1 for long-distance.)

```
Press Start
919725552009_
```

7 Press **START**.

By pressing **START**, you've just given your machine a command. In turn, your machine gives this action a command number as it scans the fax document.

This command number appears on the first line of the LCD for a few seconds:

```
== Command:01 ==
```

You'll need to know this command number if you later wish to cancel the transmission or to print a stored document (see pages 1.23).

- 8 Now, everything is up to the machines — yours and the one you're dialing.
 - If the fax has been set for *Quick Memory transmit*, your machine scans the first page of your document into memory, then dials the other fax. When it makes contact, your machine transmits the stored document from memory while at the same time scanning the remaining pages of your document into memory. (To set *Quick Memory transmission*, see pages 2.31.)
 - If the fax has been set for the *normal memory transmit*, your fax scans the entire document into memory, then dials the other fax. When it makes contact, your machine transmits the entire stored document from memory.
 - If the fax is set for *non-memory transmission*, your machine simply dials the other fax. When it makes contact, your machine feeds the document through, scanning and transmitting it as it goes.

Note: The more "stuff" (called *black coverage*) your machine "sees" on a page, the more slowly the page feeds through as the fax scans it. And even if the page is relatively clean, sending it in grayscale mode or at certain resolutions makes your machine "see" more "stuff." The same is true if you set the contrast to Dark.

Important: If you want to *cancel* a transmission while *scanning* the document, press the **STOP** key.
If you want to *cancel* a transmission in progress, use the *Review Commands* function. See "Review Commands, an introduction" page 1.23.

9 At the end of the operation, your fax machine beeps and displays:

```
972-555-2009
** Complete **
```

Important: Whenever you transmit a document, what actually appears on the top line of the display depends on information stored in the remote fax. The line may even be blank.

Note: If the call fails, see "Redialing," page 1.22.

Sending a fax using the FBS

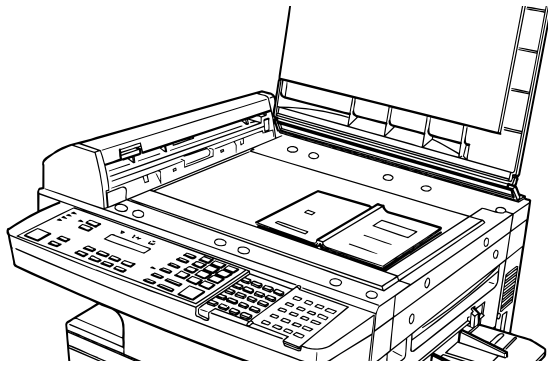

1 If the machine is already in Fax mode, skip to step 2.
If the machine is in Copy mode, press **COPY/FAX** to change to Fax mode.

2 If there isn't a document in the feeder, skip to step 3.
If there's a document in the feeder, remove it.

3 Open the book-cover.

4 Place the document **face down** on the FBS and align it with the document scale on the right, then gently close the book-cover.
Make sure the document is set beyond the right front corner.

Important: Gently close the book-cover so that you don't catch your hands, possibly injuring them.
When a thick document, such as a book, is on the FBS, **do not press strongly** from the top of the book-cover. This may break the contact glass and cause an injury.

5 Press **BOOK DOC SIZE** to select the document size, letter (displayed as Ltr), legal (Legl), half-letter (HLtr) or B4. (Half-letter is 8.5" wide × 5.5" tall; B4, widely used internationally, is 10.1" × 14.3".)

Enter Scan Size
Ltr

Legl

HLtr 

B4

6 *Adjust resolution and contrast if necessary.*
Press **RESOLUTION** to change the resolution.
Press **CONTRAST**, then press ◀ or ▶ to change the contrast.

7 *Enter the fax number.*
Also, enter any access codes necessary, just as you would for a regular phone call. (Example: Enter 9 to "dial out" from an office telephone system, or 1 for long-distance.)

Press Start
919725552009_

8 Press **START**.

By pressing **START**, you've just given your machine a command. In turn, your machine gives this action a *command number* as it scans the fax document.

This command number appears on the first line of the LCD for a few seconds:

== Command:01 ==

You'll need this command number to cancel the transmission or to print a stored document (see pages 1.23).

Then your machine will scan the document into the memory.
While your machine scans the document, the LCD will show:

919725552009
Ltr NextDoc Mem100%

9 When the scanning is done, the LCD will show:

Start Scan → Next
Tx Start → Start

If you want to send more pages, proceed to step 10.
Otherwise, press **START** to start the transmission, and skip to step 11.

10 Place the next page, then press **NEXT** to start scanning.

Note: If necessary, select the document size (see step 5).

To send any more pages, repeat steps 9-10.
Otherwise, press **START** to start the transmission, and skip to step 11.

- 11** Now, everything is up to the machines — yours and the one you're dialing. When it makes contact, your machine transmits the stored document from memory.

Important: If you want to *cancel* a transmission while *scanning* the document, press the **STOP** key.
If you want to *cancel* a transmission in progress, use the *Review Commands* function. See “Review Commands, an introduction” page 1.23.

- 12** At the end of the operation, your fax machine beeps and displays:

```
972-555-2009
** Complete **
```

Important: Whenever you transmit a document, what actually appears on the top line of the display depends on information stored in the remote fax. The line may even be blank.

Note: If the call fails, see “Redialing,” page 1.22.

Sending a fax using monitor/call or a handset

You also can fax a document using either the monitor speaker or the optional handset to dial the call.

Note: Faxing this way disables “V.34” mode and sends the fax in normal ITU-T Group 3 fashion. This may slow transmission for this document. See page 3.20 for more information.

- 1** *Insert the document to the ADF.*
- 2** *Adjust resolution and contrast if necessary.*
Press **RESOLUTION** to change the resolution.
Press **CONTRAST** to change the contrast.
- 3** *Obtain a dial tone, either by:*
 - Pressing **MONITOR/CALL**
 - ... or ...
 - Lifting the optional handset.

In either case, the LCD shows:

```
** Tel Mode **
_
```

- 4** *Enter the fax number by using the numeric keypad.*
Also, enter access codes with the number, just as for a regular phone call.

Note: For information on one-touch and speed-dial numbers, see 2.8–2.14.

```
** Tel Mode **
919725552009_
```

- 5** *When you hear fax tones from the remote unit, press **START**.*
Note: If a person answers the phone, use the optional handset to tell that person that you're trying to send a fax. When you hear fax tones, press **START**.
- 6** If you're using an optional handset, hang up after pressing **START**.
- 7** At the end of the operation, your fax machine beeps and displays:

```
972-555-2009
** Complete **
```

Note: If the call fails and you used **MONITOR/CALL** to dial, press **MONITOR/CALL** to hang up. Or if you've pressed **START** to begin the fax transmission, press **STOP** to end it.

Also see “Redialing manually,” next page, if the call fails.

Redialing

If your fax call fails, your machine automatically redials it. In this *Auto Redial mode*, your fax *automatically redials* the number every few minutes (see “Changing redial settings,” right column) until one of the following happens:

- It reaches the remote fax machine.
- It has attempted the number of redials programmed and has still not connected (see “Changing redial settings,” right column).

While in the *Auto Redial mode*, the machine can continue to receive faxes and can make as many as 99 fax transmissions.

Note: If you used either the speaker or a handset to dial the call, you must redial manually (see below).

Note: If the last redial attempt fails, your machine may print (and/or display) error messages. For more information, see pages 3.11.

Redialing manually

You can always redial calls manually. And you *must* redial manually if you used either the monitor speaker or an optional handset to dial the failed call.

To redial a fax call manually *without* using the monitor speaker or an optional handset:

- 1** Make sure the document is in the feeder and that the resolution and contrast are set.
- 2** Press **REDIAL/PAUSE, START**.

To redial a fax call manually *with* the monitor speaker or an optional handset:

- 1** Make sure the document is in the feeder and that the resolution and contrast are set.
- 2** Press **MONITOR/CALL** or lift the optional handset to get a dial tone.
- 3** Press **REDIAL/PAUSE**.
- 4** *When you hear fax tones from the remote unit, press START.*
Note: If a person answers the phone, use the optional handset to tell that person you’re sending a fax. When you hear fax tones, press **START**.

To redial a voice call manually using the optional handset:

- 1** Lift the optional handset to get a dial tone.
- 2** Press **REDIAL/PAUSE**. When the other person answers, use the optional handset to speak to that person.

Changing redial settings

It’s up to you how many times the fax redials a number and how long it waits between redials (that length of time between calls is the *redial interval*). To program the redial settings:

- 1** Press **►/PROGRAM, J, 0, 6, ENTER**.

Set # Of Redials # (02-15):02

- 2** Use the numeric keypad to enter the number of redials you want. Choose from 2 to 15 redials. In this example, we’ve entered 03.

Set # Of Redials # (02-15):03

Important: Enter a leading zero when entering a quantity less than 10.

- 3** Press **ENTER** to save the setting.

- 4** The LCD now shows:

Set Redial Interval Inter. (1-5):1

- 5** Use the numeric keypad to enter the length you want between redial attempts. Choose from 1 to 5 minutes. In this example, we’ve chosen 4.

Set Redial Interval Inter. (1-5):4

- 6** Press **ENTER** to save the setting.

Review Commands, an introduction

Your fax machine can store many “jobs” in its memory. And it keeps track of each one by assigning it a *command number*, like “C01.”

Delayed commands, redial attempts and current fax transmissions are all stored in your fax machine’s memory and given a command number.

The Review Commands function gives you the power to check on each job (or *command*) in your machine’s memory. It also lets you *cancel* a command if you decide not to send the document.

To cancel a command:

- 1** Press **REVIEW COMMANDS**.
The LCD shows the *first* command, indicated by its command number and the phone number it will dial. If a command is in progress, that will be the first command the LCD shows:

C01:5552009
Program/Cancel

- 2** Press **◀** or **▶**/**PROGRAM** until the command you want to cancel appears.
- 3** Press **CANCEL**. The LCD shows:

C01:5552009
Check Program/Cancel

- 4** If you want to cancel this command, press **CANCEL** again.
- 5** The LCD now shows the next command.
If you want to cancel it, too, go back to step 4.
If you *don't* want to cancel this command but *do* want to review *other* commands, press **▶**/**PROGRAM** until the command you want appears. Then go back to step 4.
If you want to stop reviewing the stored commands, press **STOP** to return the machine to standby mode.

For more information on the Review Commands function, see page 2.18.

Receiving faxes

Answering calls manually

In any reception mode, you can always answer calls manually *if you have an optional handset installed*. Just pick it up, as you would if using a normal phone.

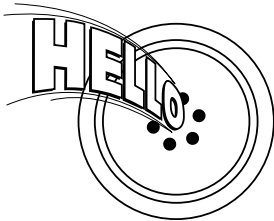

If you hear someone speaking to you, use your optional handset to speak back.

If you hear *fax tones* (“beep — beep — beep”), press **START** and hang up the optional handset. The fax machine will begin receiving a fax.

Note: Receiving this way disables “V.34” mode so that the machine receives the fax in normal ITU-T Group 3 fashion. (See page 3.20.)

Note: Don’t try to answer a call by pressing **MONITOR/CALL**. The monitor function is for dialing only.

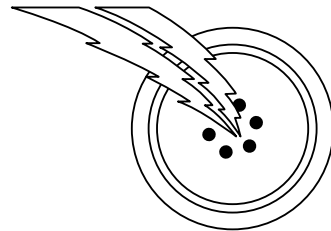

Answering fax calls using another phone, not the fax machine

If you have one phone line ringing to several phones in your office and *you have an optional handset attached to your fax*, there’s no need to run to the fax machine to answer every call. If you happen to answer a fax call while you’re at another extension, put the handset down, but don’t hang up. Walk to the fax machine and pick up the optional handset. Then press **START**.

After you press **START**, hang up both the fax machine’s handset and the second telephone’s handset. Because remote fax machines will wait several seconds to hear reception tones from your unit, you have about 30 seconds to walk to your fax, pick up the handset, and press **START**.

Reception modes

Your fax machine has five different reception modes — *Tel Ready*, *Fax Ready*, *Fax/Tel Ready*, *Tel/Fax Ready* and *Ans/Fax Ready*. We’ll explain each of these in this section.

Tel Ready mode

- Use it if:**
- You want to use the same line for both fax and phone calls *and*
 - On that line, you’re using at least one other phone which is *not* connected to your fax machine *or*
 - You have an optional handset installed on your fax machine

In this mode: Your fax machine never answers calls automatically. You must answer each call as described in “Answering calls manually” (this page, left column).

To select Tel Ready:

1 Press **COPY/FAX** to change to the fax mode, if the machine isn’t the fax mode.

2 Press **▶/PROGRAM, I**, and then press **ENTER** *six times*. The LCD shows your current default reception mode:

Fax Ready
Program/Enter

3 Press **◀** or **▶/PROGRAM** until the LCD shows:

Tel Ready
Program/Enter

4 Press **ENTER** to save the setting.

In the Tel ready mode, the **AUTO ANSWER** light is not lit.

Fax Ready mode

Use it if: Your fax machine uses its own phone line and doesn't share it with a phone or an answering machine.

In this mode: Your fax machine answers each call and attempts to receive a fax.

To select Fax Ready:

1 Press **COPY/FAX** to change to the fax mode, if the machine isn't the fax mode.

2 Press **▶/PROGRAM, I**, and then press **ENTER** *six times*. The LCD shows your current default reception mode:

```
Fax Ready
Program/Enter
```

3 Press **◀** or **▶/PROGRAM** until the LCD shows:

```
Fax Ready
Program/Enter
```

4 Press **ENTER** to save the setting.

5 Press **STOP** to return the machine to standby mode.

In the Fax ready mode, the **AUTO ANSWER** light is lit.

Fax/Tel Ready mode

The Fax/Tel Ready mode is a combination of the Fax Ready and Tel Ready modes.

Use it if: An optional handset is installed on your fax machine
and
You're using the machine as both a fax machine and a telephone

In this mode: Your fax machine answers each call without ringing. If you receive a voice call, it alerts you with a special ring.

To select Fax/Tel Ready:

1 Press **COPY/FAX** to change to the fax mode, if the machine isn't the fax mode.

2 Press **▶/PROGRAM, I**, and then press **ENTER** *six times*. The LCD shows your current default reception mode:

```
Fax Ready
Program/Enter
```

3 Press **◀** or **▶/PROGRAM** until the LCD shows:

```
Fax/Tel Ready
Program/Enter
```

4 Press **ENTER** to save the setting.

5 Press **STOP** to return the machine to standby mode.

Now your fax machine receives faxes silently *but also* alerts you when a regular voice call comes in. (Your fax machine also beeps once at the end of each reception.)

If a voice call comes in, your fax machine detects it and sounds a special ring. If you hear it, answer using your optional handset.

Note: This Fax/Tel Ready mode won't turn off ringers on other telephones in your house or office. Other phones won't distinguish between fax and voice calls.

In the Fax/Tel ready mode, the **AUTO ANSWER** light is lit.

Tel/Fax Ready mode

The Tel/Fax Ready mode is a combination of the Tel Ready and Fax Ready modes.

Use it if: An optional handset is installed on your fax machine
and
You're using the machine as both a telephone and a fax machine

In this mode: Your fax machine rings the number of times you've identified in the user settings. If you don't use the optional handset to answer the call, your fax machine answers the call. If a caller sends a fax, your machine begins receiving it. If a voice call comes in, your machine detects it and sounds a special ring, telling you to answer using the optional handset.

To select Tel/Fax Ready:

- 1 Press **COPY/FAX** to change to the fax mode, if the machine isn't the fax mode.
- 2 Press **▶/PROGRAM, I**, and then press **ENTER** *six times*. The LCD shows your current default reception mode:

Fax Ready
Program/Enter
- 3 Press **◀** or **▶/PROGRAM** until the LCD shows:

Tel/Fax Ready
Program/Enter
- 4 Press **ENTER** to save the setting.
- 5 Press **STOP** to return the machine to standby mode.

In the Tel/Fax ready mode, the **AUTO ANSWER** light is lit.

Ans/Fax Ready mode

Use it if: You're using an answering machine that's connected directly to your fax machine.

In this mode: An answering machine connected to your fax machine answers each call. If a voice call comes in, the answering machine begins to record the incoming message. If your fax machine hears a fax tone, it begins receiving the fax message.

To select Ans/Fax Ready:

- 1 Press **COPY/FAX** to change to the fax mode, if the machine isn't the fax mode.
- 2 Press **▶/PROGRAM, I**, and then press **ENTER** *six times*. The LCD shows your current default reception mode:

Fax Ready
Program/Enter
- 3 Press **◀** or **▶/PROGRAM** until the LCD shows:

Ans/Fax Ready
Program/Enter
- 4 Press **ENTER** to save the setting.
- 5 Press **STOP** to return the machine to standby mode.

In the Ans/Fax ready mode, the **AUTO ANSWER** light is lit.

Using an answering machine with your fax machine

To connect your answering machine to your fax machine:

- 1 Set the fax machine for Ans/Fax Ready, as described on page 1.26.
- 2 Set your answering machine to answer calls after *no more than* two rings. (See the answering machine's instructions if necessary.)
- 3 Create a new outgoing message on your answering machine. Here's a suggested message:

*Hello! You've reached [your name or telephone number]. To leave a **voice** message, please wait for the beep. To send a **fax**, press **START** on your fax machine. Thanks for calling!*

Important: Your answering machine's outgoing message must be *no longer than* 10 seconds.

Detection of "silent" fax machines

Some older fax machines don't send fax tones when transmitting, which can cause problems when using an answering machine with your fax.

But your fax machine can accommodate these "silent" machines *without* disrupting your answering machine operation. For more information, call your authorized Muratec dealer.

If the paper runs out

Getting the word from your machine

When your fax machine runs out of paper, the machine beeps, the **REPLACE PAPER** light glows and the LCD indicates which source has run out of paper, either the cassette or the multipurpose tray.

In this example, the cassette is empty:

Fax Ready
Check Rx Paper

Your fax machine cannot *print* fax messages or copies without paper. But it can still receive documents into its memory, as described in the section below.

Receiving when out of paper

If your machine runs out of paper, it stores up to 100 fax *receptions* in its memory. This is called *out-of-paper reception*. Once you refill the paper supply, the fax machine prints the stored messages automatically.

Note: The number of *pages* (not *receptions*) your fax machine can store for out-of-paper reception will vary. It depends on:

- Your machine's memory capacity
- Types of documents being sent to your machine
- Resolution of documents being sent to your machine

(See Specifications, page AL.1.)

Making copies

Your fax machine also doubles as a convenience *copier*.

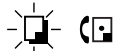

COPY FAX

To make copies with your fax machine, press **COPY/FAX** to change to the Copy mode.



When the machine is in the Copy ready mode, the LCD will show:

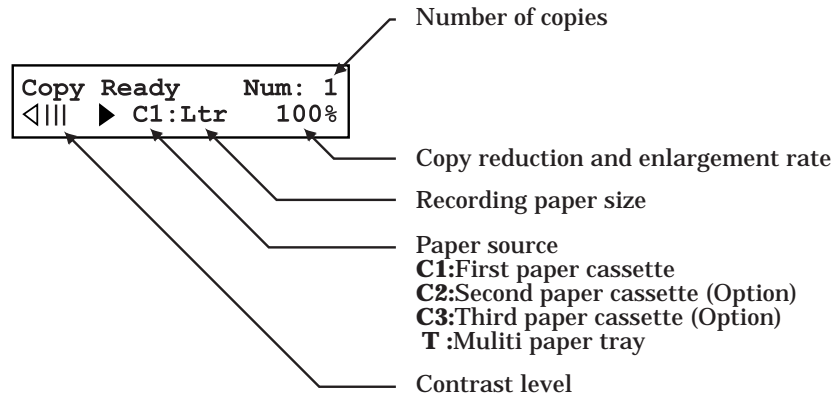

Making copy settings

Number of pages

Use the numeric keypad to enter the desired number of copies for the document.

Copy reduction or enlargement rate

Your fax machine can make enlarged and reduced copies. For more information, see “Setting of enlargement or reduction for copying,” page 1.31.

Note: The copy enlargement and reduction rate setting affects only copying. It doesn't affect the fax reception reduction rate (see pages 2.3–2.3).

Paper source and paper size

If you wish to select the paper supply source manually, press **PAPER SIZE?** repeatedly until your desired paper source appears:

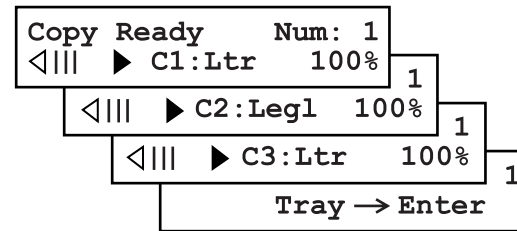

You may also choose from either the standard paper cassette (C1) or the Multi paper tray (T). If your machine also has either or both of the two optional cassettes, you may also choose (C2) or (C3). To use the Multi paper tray, press **ENTER** while the display shows:

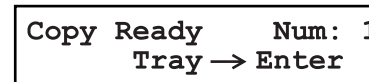

Then, press **PAPER SIZE?** to set paper size. This is the size of the paper in either the paper cassette (or cassettes, if you have one or both of the optional cassettes) or Multi paper tray. You can set letter- or legal-sized paper in the paper cassette(s), and letter-, legal- or half-letter-sized paper in the Multi paper tray. When you set transparency film on the multi paper tray, please select “OHP” mode.

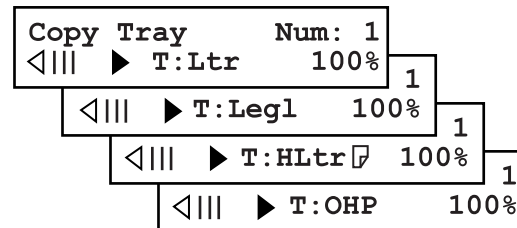

Contrast level

See “Contrast” (pages 1.17–1.18) for more information.

Sort copy

Press **Sort COPY** to toggle (switch on or off) sorting copy if necessary. The initial setting is Off.

How to copy

Copying using the ADF

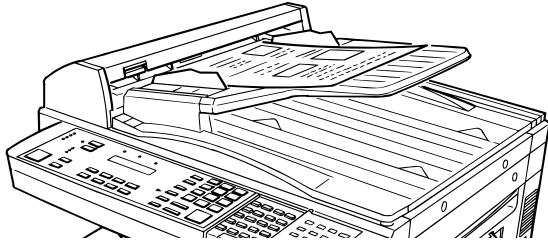

- 1** If necessary, press **COPY/FAX** to change to Copy mode. Otherwise, proceed to step 2.
- 2** Prepare the document just as you would to send a fax.
Note: There are certain types of documents you never should insert into your fax machine. (You might wish to review “Things NOT to put in your fax,” page 1.17.)
- 3** Insert your document **face up**. Adjust the document guides for a correct fit. When the document is correctly inserted, you’ll hear a short beep.
Note: Make sure that all the pages are the same size and thickness. **Do not** attempt to feed documents of different size and thickness in the same stack.
- 4** Adjust resolution and contrast if necessary. Press **RESOLUTION** to change the resolution. Press **CONTRAST**, then press ◀ or ▶ to change the contrast.
- 5** Set the reduction rate, if you want. (See “Setting of enlargement or reduction for copying,” page 1.31.)
- 6** If you want to make only one copy of each page of the document, skip to step 9. Otherwise, proceed to step 7.

- 7** Use the numeric keypad to enter the desired number of copies for each page in the document. You may choose one to 99 copies. Here, we’ve entered “3” to choose a setting of three copies.

Copy Ready	Num: 3
< ▶ C1:Ltr	100%

- 8** Press **Sort COPY** once or twice to “toggle” (switch on or off) the sorting of copies, as desired.
- 9** Press **START** to begin the copying process.

Note: To stop the copying before it is through, press **STOP**.

Note: Thanks to your machine’s GuardAccess® feature (see page 2.37 for more), copying doesn’t keep you incommunicado while in progress: you can start a fax or voice call and even receive a voice call during copying.

When using the FBS

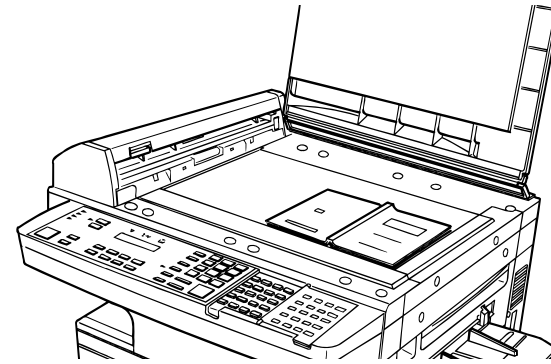

- 1** If necessary, press **COPY/FAX** to change to Copy mode. Otherwise, proceed to step 2.
- 2** Open the book-cover, place your document face down on the FBS and align it with the scale on the right.
Note: Be sure that you place the original document on the FBS in the same orientation as the paper in the paper source (which you’ll select in step 4).
- 3** Gently close the book-cover.
- 4** Press **PAPER SIZE?** to select recording paper (see page 1.28).

Getting started

- Adjust resolution and contrast if necessary. Press **RESOLUTION** to change the resolution. Press **CONTRAST**, then press ◀ or ▶ to change the contrast.
- Set the reduction or enlargement rate, if you want. (See “Setting of enlargement or reduction for copying,” page 1.31.)
- If you want to make only one copy of each page of the document, skip to step 10. Otherwise, proceed to step 8.
- Use the numeric keypad to enter the desired number of copies for each page in the document. You may choose one to 99 copies. Here, we’ve entered “3” to choose a setting of three copies.

```
Copy Ready    Num: 3
<||| ▶ C1:Ltr  100%
```

- Press **SORT COPY** once or twice to “Toggle” (switch on or off) the sorting of copies, as desired.
- Press **START** to begin the copying process.

Note: To stop the copying before it is through, press **STOP**.

Note: Thanks to your machine’s QuadAccess® feature (see page 2.37 for more), copying doesn’t keep you incommunicado while in progress: you can start a fax or voice call and even receive a voice call during copying.

Using the Multi paper tray

When you need to use a size of paper not currently loaded in your machine’s paper cassette(s), or when you want to use a special type of paper (such as transparency film), use the Multi paper tray.

Important: If loading transparency (OHP) film into the multi paper tray, be sure that the sheet is designed for laser printers and not for copiers. Also, be sure that the film does not have a paper backing and/or a leading strip. If it does, remove the paper backing and/or strip before inserting. Only film should go in, not film with any backing or strip.

- Either insert the document in the **ADF** or place it on the **FBS**.

- Place a sheet of printout paper on the Multi paper tray. Then align the paper guides to the sheet’s edges and insert the sheet until it comes to a stop.

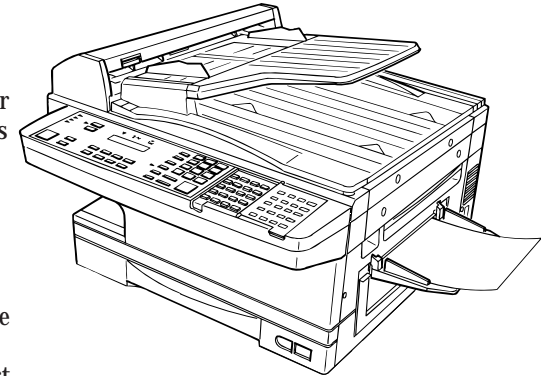

Note: Place the original document in the same orientation as the paper in the paper source (which you’ll select in step 5, below).

- If you are going to make more than one copy, you should insert the printout paper only one page at a time.
- You may use letter-, legal- or half-letter sized paper. (Half-letter is 8.5” wide × 5.5” tall.)

- Press **PAPER SIZE?** repeatedly until the following display appears:

```
Copy Ready    Num: 1
                Tray → Enter
```

- Press **ENTER**.
- Then, if necessary, press **PAPER SIZE?** again to select a same size of recording paper you placed document on the **ADF** or **FBS**. You can select either letter-, legal- or half-letter-sized paper.

```
Copy Tray     Num: 1
<||| ▶ T:Ltr   100%  1
<||| ▶ T:Legl  100%  1
<||| ▶ T:HLtr  100%  1
<||| ▶ T:OHP   100%  1
```

Note: When you use transparency film, please select “OHP” mode. You can use letter-sized transparency film.

- If necessary, select desired resolution, contrast, reduction/enlargement rate. (See “Setting of enlargement or reduction for copying,” next page.)
- Press **START** to begin the copying process.

Setting of enlargement or reduction for copying

Your fax machine is capable of enlargement and reduction when copying.

Note: The copy enlargement and reduction rate setting is available only for copying, not for faxing.

Important: Copy enlargement is available only for copying using the FBS; it is not available for copying using the ADF.

To change the reduction or enlargement rate for copying, either select a preset rate or directly enter a rate.

Selecting a preset rate

Either . . .

- Press **ENLARGE** to select one of the following fixed enlargement rates.

200%

129% : Half-letter (5.5" × 8.5") → Letter (8.5" × 11")

100%

. . . or . . .

- Press **REDUCE** to select one of the following fixed reduction rates.

78%: Legal → Letter

64%: Ledger (11" × 17") → Letter (8.5" × 11")

Directly entering a rate

Using the numeric keypad, directly enter the reduction or enlargement rate by doing one of the following.

Either . . .

1 Press #.

2 Enter your desired rate using the numeric keypad. You can set any rate from 50% reduction through 200% enlargement.

3 Press # again.

. . . or . . .

Press ◀ or ▶ to adjust the rate, at 1% intervals, from/including 50% reduction through 200% enlargement.

Copy protection

With such a versatile copier built right into your fax machine, you might want to make sure it doesn't become too tempting to some people whose unauthorized copying could deplete your machine's supplies more rapidly. So, to limit the use of your fax machine to only sending and receiving faxes — in other words, to activate *copy protection*:

1 If the machine is in Fax mode, skip to step 2. Otherwise, press **COPY/FAX** to change to Fax mode.

2 Press **PROGRAM, J, 0, 3, ENTER**.

```
Copy Protect :Off
Program/Enter
```

3 Press **PROGRAM** to turn on copy protection.

```
Copy Protect :On
Program/Enter
```

4 Press **ENTER**

```
Copy Protect
** Complete **
```

While this setting is active, whenever someone tries to change the machine to Copy mode, the machine will sound a brief alarm tone and display:

```
Fax Ready
Copy Off
```

Important: To turn off copy protection off so that you can again use the machine's copying function, repeat steps 2-4, above (step 1 is unnecessary since the machine will be in Fax mode) except that, in step 3, you press **PROGRAM** so that the display shows:

```
Copy Protect :Off
Program/Enter
```

Using your fax machine as a phone

Your fax machine can also be used as a phone, if you have an optional handset installed. The following is a brief look at the machine's telephone features.

Redial

Press **REDIAL/PAUSE** to redial the last number dialed on your machine.

Dialing with the monitor speaker

Because your machine has a monitor speaker, you can dial without picking up the handset. For hands-free dialing:

- 1 Press **MONITOR/CALL**. You'll hear a dial tone (unless you have set your speaker volume to *Off*; see page 1.13), and the LCD shows:

** Tel Mode **

- 2 Dial the number you want. Use either the numeric keypad, a one-touch key or a speed-dial number to dial.

Note: Remember, your fax machine's monitor speaker is *not* a speakerphone. If a person answers the call, pick up the handset to speak.

Note: If the call fails, press **MONITOR/CALL** to hang up.

EasyDial directory dialing

The EasyDial directory feature is available for regular phone calls as well as fax calls. Review the EasyDial instructions on page 2.15 for more information.

Checking the fax reception mode

While using an optional handset for your call, if you press **CLEAR ALL**, the LCD shows the current fax reception mode. Press **CLEAR ALL** again to return to the TEL mode.

Dialing in the event of a power failure

Your fax machine can receive telephone calls even in the event of a power failure if an optional handset is attached. *But it cannot* send or receive a fax document.

This page intentionally blank.

Beyond the basics

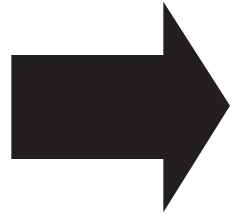

*We've covered
the "musts."
Now, let's explore
the goodies.*

Entering settings for your fax machine	2.1
Autodialer	2.7
Broadcasting	2.16
Delayed transmission	2.17
Batch transmission	2.20
Special features	2.24
F-Code communication	2.38
Programmable one-touch keys	2.48
Security features	2.56

Entering settings for your fax machine

The EasyStart feature guided you through the “just-gotta” settings on your machine. In the next few pages, we’ll cover additional settings.

Scan settings

Four different settings tell your machine how to scan documents. The initial factory settings are probably right for most applications, so try using them before changing any of these settings:

- **Primary resolution mode** — Sets the resolution for your documents. Choose either normal, fine, superfine (“S Fine” on the LCD) or grayscale mode (“Gray”).
- **Primary contrast mode** — Sets how light or dark you want faxed documents to be when they arrive at their destinations.
- **Scanning width** — Sets how wide an area your machine scans for each page.

Note: The primary settings you choose effect your fax activity only.

To set these modes:

- 1 Press **▶/PROGRAM, J, 0, 1, ENTER**. The LCD asks you to select a *resolution*:

```
Primary      :Normal
Program/Enter
```

- 2 Press **◀ or ▶/PROGRAM** until the mode you want appears. In this example, we’ve chosen fine resolution.

```
Primary      :Fine
Program/Enter
```

- 3 Press **ENTER** to save the setting. The LCD asks you to select a *contrast setting*:

```
Contrast     :Normal
Program/Enter
```

- 4 Press **◀ or ▶/PROGRAM** until the mode you want appears. In this example, we’ve chosen light contrast.

```
Contrast     :Light
Program/Enter
```

- 5 Press **ENTER** to save the setting. The LCD asks you to select a *scanning width*:

```
Scan Width   :A3
Program/Enter
```

For most uses, “A4” is the proper setting. It scans the central 8.2” of each page. But for documents with an unusual width, you may want to use the “B4” and “A3” settings, which scans the central 9.9” and 11.6” of each page. (See “A4, B4, A3” in the Glossary on page 3.17.)

- 6 Press **◀ or ▶/PROGRAM** until the mode you want appears. In this example, we’ve chosen “A4”.

```
Scan Width   :A4
Program/Enter
```

- 7 Press **ENTER** to save the setting.

By following the steps above, you’ve set your *defaults* for scanning. Before sending documents, you can “override” these default scan settings *for that transmission*.

To *override* the default resolution and contrast settings before sending a document:

- Press **RESOLUTION** to change the resolution.
- Press **CONTRAST** to change the contrast.

Once your document is transmitted, your machine returns to its default settings.

Using CODE to enter characters

Some settings give you a chance to enter an identifying name (see EasyStart, page 1.15–1.16). You can do this with the one-touch key, and you can also use the CODE key.

To use the CODE key to enter characters:

- 1 When the machine prompts you to enter a name, press CODE. The display changes to:

Your Name ;Code
_

- 2 Find the character you want to enter in the chart below.

First keypress

		2	3	4	5	6	7	A	B	C	D	E	F
Second keypress	0		0	@	P	`	p	Ç	É		↑	α	p
	1	!	1	A	Q	a	q	ü	æ	°	↓	ä	q
	2	"	2	B	R	b	r	é	Æ	Γ	á	β	θ
	3	#	3	C	S	c	s	â	ô	∟	í	ε	∞
	4	\$	4	D	T	d	t	ä	ö	·	ó	μ	Ω
	5	%	5	E	U	e	u	à	ò	·	ú	σ	ù
	6	&	6	F	V	f	v	á	û	∫	ñ	ρ	Σ
	7	'	7	G	W	g	w	ç	û	∫	Ñ	9	π
	8	(8	H	X	h	x	ê	ÿ	\	á	∫	∞
	9)	9	I	Y	i	y	ë	Ö	"	ø	→	∞
	A	*	:	J	Z	j	z	è	Ü	ø	¿	j	∞
	B	+	:	K		k	{	í	¢	ø	∟	x	∞
	C	,	<	L	¥	l		í	£	<	∟	¢	∞
	D	-	=	M	j	m	}	i	¥	∫	∫	∫	∞
	E	.	>	N	^	n	→	Ä	Pt	"	«	ñ	∞
	F	/	?	O	_	o	←	À	f	*	»	∞	∞

The legends in the black border indicate which key you press, and in which order, to get a given character. For example, to get a back-slash (\) character, you'd press C, 8. (The blank areas for 2, 0 and C, 0 indicate spaces.)

- 3 To enter each character, press the key combination listed on the chart.

Important: Remember, there are three ways to enter characters:

Enter	Using
Numbers	Numeric keypad
Letters/characters	One-touch keys
Letters/characters/numbers	CODE chart for key combinations

Note: If you want to erase characters, press CANCEL to erase to the left. If you want to change just one character in the name, press ◀ to move the cursor left, or ▶/PROGRAM to move it right. Press CANCEL to erase the character. Then re-enter the character correctly.

- 4 Press ENTER to save the name.

Print settings

You can set three parameters for printing received fax messages:

- Print reduction rate
- Reduction margin
- Half-page reception

You set all three in the same procedure, discussed on page 2.3. Following is a short explanation for each:

Print reduction rate

Print reduction lets you set the machine to reduce large incoming documents to a size which fits on the paper in your machine. This setting doesn't affect copies you may make with your machine. Fortunately, however, it also has copy reduction (see "Setting of enlargement and reduction for copying" on page 1.31).

Below are the options for both the print reduction and copy reduction settings:

Setting	What it does
Auto	Automatically reduces printouts at variable rates down to a minimum of 50%. Tries to reduce printout to fit on one sheet of your selected paper size. If it can't, prints the image at 100% size on two or more pages.
100%	Does not reduce document. (Due to the sender's TTI, this may print <i>two</i> pages when receiving a one-page fax document. See 97%, below.)
97%	Reduces an original so that the final printout of a one-page-document (<i>if the original isn't larger than the paper in your machine</i>) will only be one page long, even with the TTI.
91%	Reduces documents slightly more.
81%	Reduces documents even more. Helpful for some international stationery sizes, as well as special applications.
75%	Turns <i>legal-sized</i> originals into <i>letter-sized</i> printed copies.

For best results ...

Whenever possible, **load the correct size of paper before receiving a fax (or making a copy) of that size.** Although it's convenient, the reduction feature can't be used for *every* situation.

Reduction margin

Your fax machine's *reduction margin* is measured in millimeters (mm). We'll define *reduction margin* by explaining how it's used:

When a fax message enters your machine's electronic brain, the machine measures the message's length and compares it to **(a)** the length of your selected paper **plus** **(b)** the reduction margin you set. If the length of the incoming message is shorter than **(a)** and **(b)** put together, your machine prints the message on just one sheet. If it's longer, your machine prints the message on more than one sheet.

Note: An *Auto* reduction setting and a reduction margin setting of *40mm* will print most incoming faxes as single pages. Try this combination first and then, only if you have problems with it, select different settings.

Half-page reception

Half-page reception can conserve paper if some of the faxes you receive are half-page, "memo-sized" messages. When activated, this feature tells the machine to combine two of these half-page receptions onto a single sheet. Half-page reception only combines half-page messages sent back-to-back *during the same transmission*. It won't combine two half-page faxes from separate transmissions.

Adjusting the print settings

- 1 Press **▶/PROGRAM, J, 0, 2, ENTER**. The LCD shows the current print reduction rate:

```
Prnt Reduc Rate:Auto
Program/Enter
```

- 2 Press **◀** or **▶/PROGRAM** until the reduction setting you want appears. In this example, we've chosen *91%*.

```
Prnt Reduc Rate: 91%
Program/Enter
```

- 3 Press **ENTER** to save the setting. The LCD shows the current reduction margin:

```
Prnt Reduc Rate: 91%
Margin (00-85mm): 40
```

- 4 Use the numeric keypad to enter the reduction margin you want. If necessary, press **◀** or **▶/PROGRAM** to move the cursor. In this example, we've chosen *38mm*.

```
Prnt Reduc Rate: 91%
Margin (00-85mm): 38
```

- 5 Press **ENTER** to save the setting. The LCD shows the current setting for half-page reception:

```
Half Page Recpt:Off
Program/Enter
```

- 6 Press **◀** or **▶/PROGRAM** until the setting you want appears. In this example, we've chosen *On*.

```
Half Page Recpt:On
Program/Enter
```

- 7 Press **ENTER** to save the setting.

Image Rotation

When this feature is activated, incoming fax messages will be rotated automatically to fit on the paper.

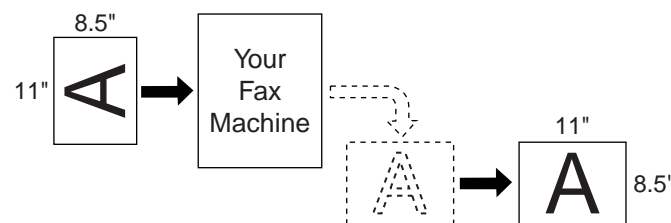

- 1 Press **▶/PROGRAM, J, 1, 8, ENTER**. The LCD shows:

```
Rotate Rx :Off
Program/Enter
```

- 2 Press **◀** or **▶/PROGRAM** until the setting you want appears. In this example, we've chosen *On*.

```
Rotate Rx :On
Program/Enter
```

- 3 Press **ENTER** to save the setting.

Setting the number of rings

You can set how many times your fax machine will ring before answering a call. Choose from 1 to 10 rings.

- 1 Press **▶/PROGRAM, J, 0, 5, ENTER**. The LCD shows:

```
Set # Of Rings
#      (01-10):02
```

- 2 Use the numeric keypad to enter the number of rings you want, from 1 to 10. Here, we've chosen 4 rings.

```
Set # Of Rings
#      (01-10):04
```

Note: If you enter 00 (zero), the machine will beep briefly to warn you that it can't accept that setting.

- 3 Press **ENTER** to save the setting.

Setting ECM

"Line noise," or static on the line during a call, can easily disrupt the flow of data from one fax machine to another.

That's why your fax machine gives you the option of using *Error Correction Mode (ECM)*. When two fax machines communicate while running in ECM, the sending machine automatically *checks* the data as it sends. If the receiving fax machine can't verify the transmission, the first machine will re-send it as necessary.

Note: ECM gives you a better chance of transmitting a fax document over a bad phone line, but it could also slow down the transmission time. And the worse the line is, the slower the transmission. That's why the machine lets you turn ECM on or off as needed.

Note: Not all fax machines have ECM. If you've activated ECM and then transmit to a fax machine not currently using ECM, there will be no change in the fax transmission from a usual, non-ECM transmission.

- 1 Press **▶/PROGRAM, J, 0, 7, ENTER**. The LCD shows the current ECM setting:

```
ECM Mode      :On
Program/Enter
```

- 2 Press **◀** or **▶/PROGRAM** until the mode you want appears. In this example, we've chosen *Off*

```
ECM Mode      :Off
Program/Enter
```

- 3 Press **ENTER** to save the setting.

Setting silent mode

Silent mode allows you to mute the ringer, the alarm and the key tones.

- **Ringer** — If you turn the ringer off in silent mode, a ring alerts you when you receive fax or voice call and a call request.
- **Alarm** — If you disable the alarm in silent mode, the sound your machine makes when an error occurs and the beep your machine makes after sending or receiving a fax or making a copy cannot be heard.
- **Key tone** — If you mute the key tone, your machine will not make a sound when you press the buttons on the control panel.

- 1 Press **▶/PROGRAM, J, 1, 9, ENTER**. The LCD shows your fax's current setting:

```
Silent Mode   :Off
Program/Enter
```

- 2 Press **◀** or **▶/PROGRAM** until the mode you want appears. In this example, we've chosen *On*.

```
Silent Mode   :On
Program/Enter
```

Note: If you chose *On*, the silent mode of *Ringer*, *Alarm* or *Key tone* can be set to be available. If you chose *Off*, the machine will ring and beep as usual.

If you chose *Off*, skip to step 10.

- 3 Press **ENTER** to save the setting. The LCD now asks if you want the ringer to be on or off:

```
Ringer Silent :Off
Program/Enter
```

- 4 Press **◀** or **▶/PROGRAM** until the mode you want appears.

If you want to turn off the ringer, select "On" and the machine will be quiet. Otherwise, the machine will ring.

- 5** Press **ENTER** to save the setting. The LCD now asks if you want the alarm turned on or off:

```
Alarm Silent :Off
Program/Enter
```

- 6** Press **◀** or **▶**/PROGRAM until the mode you want appears.
If you want to turn off the alarm, select “On” and the machine will be quiet. Otherwise, the machine will beep.

- 7** Press **ENTER** to save the setting. The LCD now asks if you want the key tones on or off:

```
Key Buz.Silent :Off
Program/Enter
```

- 8** Press **◀** or **▶**/PROGRAM until the mode you want appears.
If you want to turn off the tones, select “On” and the machine will be quiet. Otherwise, the machine will beep when the keys are pressed.

- 9** Press **ENTER** to save the setting.
If you turned off the alarm or the key tones in the steps above, your machine gives you the option of setting the volume for the alarm and key tones. If this option appears, skip to step 10.
If you didn't turn any of these off, your fax machine returns to standby mode.

- 10** The LCD shows your fax's current setting:

```
Alarm&Key Vol. :Mid
Program/Enter
```

- 11** Press **◀** or **▶**/PROGRAM until the mode you want appears.
Below are the possible settings:

```
Alarm&Key Vol. :Max
Program/Enter
```

 = Loudest setting.

```
Alarm&Key Vol. :Mid
Program/Enter
```

 = Medium setting.

```
Alarm&Key Vol. :Min
Program/Enter
```

 = Low setting.

- 12** Press **ENTER** to save the setting.

Setting the confirmation stamp

You can set your fax machine so that it will automatically place a small blue ink *stamp* mark on the front of each *original* document that it successfully scans.

Important: Turn off this feature if you're sending documents you don't want the fax to stamp.

- 1** Press **▶**/PROGRAM, **J**, **1**, **4**, **ENTER**. The LCD shows your fax's current setting:

```
Stamp :Off
Program/Enter
```

- 2** Press **◀** or **▶**/PROGRAM until the mode you want appears.
In this example, we've chosen *On*.

```
Stamp :On
Program/Enter
```

- 3** Press **ENTER** to save the setting.

Language settings

English is the language your machine initially displays on the LCD and uses to print reports. But you can set it to “speak” French, Spanish or German, too.

As you give the order for the machine to change languages, it “rolls” from English to French to Spanish to German, and then back to English.

To make the change from one language to the next, press ►/PROGRAM, #.

Checking the language

If, after making a language change, you’re not sure *which* language is showing, press ►/PROGRAM once and decide based on what you see on the LCD:

```
A Num. Une-Touche
Program./Val.
```

is French.

```
A Núm. Una-Tecla
Program./Sel.
```

is Spanish.

```
A Zielwahl
Programm/Eing.
```

is German.

If the language you see is the one you want, press STOP to return to standby mode.

If you want to change languages, press STOP to return to standby mode.

Then press ►/PROGRAM, # again to go to the next language in the cycle.

Printing your settings

After you’ve programmed settings into your machine, print a *settings list*. We recommend this, particularly if you’re sharing the machine with other users, who might change the settings.

With this list, you can quickly confirm that all of your settings are correct, without having to go back and check them on the machine. Or, if you *do* need to undo someone else’s changes, this list guides you in returning the machine to your preferred settings.

Note: Please refer to the index at the end of these instructions to locate any settings you don’t recognize or understand.

To print the settings list:

- 1 If the machine is in Fax mode, proceed to step 2. If it is in Copy mode, press COPY/FAX to change to Fax mode.
- 2 Press PROGRAM, J, 2, 1, ENTER. The display will show the following as the list prints:

```
Print Settings
** Printing **
```

Printing a program list

Your machine can also print a *program list*. This lists the functions available on your fax machine and the keystrokes needed to complete them.

Note: Please refer to the index at the end of these instructions to locate any settings you don’t recognize or understand.

To print a program list, press ►/PROGRAM, *, 8.

Autodialer

Your fax machine's *autodialer* stores your most frequently called phone and fax numbers for instant recall so you don't have to remember them. It's something like an electronic phone book.

Autodialer basics

How do you autodial?

There are two kinds of autodialer numbers. The difference between the two is how you dial them:

Type	How to dial	Amount stored
<i>One-touch</i>	Press one of the keys, marked 01-72 on the right side of the control panel	72
<i>Speed-dial</i>	Press SPEED DIAL/TEL INDEX followed by a three-digit identifier, from <i>001</i> to <i>128</i>	128
Total amount of numbers stored		200

Autodialing fax and phone numbers

Your fax machine's autodialer will hold more than just fax numbers. You can store phone numbers, too.

This is because when you use the autodialer to dial a number, the fax checks to see if there's a document in its feeder. If there is, the machine dials as a fax machine. If there isn't, it dials as a phone.

Location IDs and the EasyDial directory

When you store numbers in your autodialer, you can give these numbers descriptive names, such as "Chicago office" or "Billing department". Your machine calls this name a *Location ID*.

Your machine's autodialer sorts these location IDs alphabetically. Using your *EasyDial directory*, you can look up these numbers by their descriptive names, just as if you were using a phone book.

We'll explain how to store the numbers and location IDs in the next few pages. The EasyDial directory is discussed in detail on page 2.15.

Special Dialing Characters

Your fax machine allows you to enter special dialing characters when programming the autodialer. These characters include hyphens and dashes, which make phone numbers easier to read, and special characters needed for international calls.

The chart below briefly describes each of these characters. It also tells you what keys to press on your fax machine to store those characters in your autodialer:

Char.	What it does	Keystroke(s)
-	Makes long numbers easier to read. Doesn't change fax machine operation.	DIALING OPTIONS (<i>once</i>)
/	(<i>Has no effect in the United States.</i>)	DIALING OPTIONS (<i>twice</i>)
!	Tells your fax machine to pause until it "hears" a dial tone.	DIALING OPTIONS (<i>3 times</i>)
- /	Enters a pause. Each pause lasts two seconds (or whatever length you set; see page 1.18). Each pause uses <i>two</i> of the characters you can store in one phone number.	REDIAL/PAUSE [<i>after you enter at least one other character</i>]
- !	If your fax machine is on a pulse (<i>not</i> tone-dialing) line, switches from pulse-dialing to tone ("DTMF")-dialing. Use after the actual phone number but before any characters (such as a long-distance carrier's access code) which must be in DTMF tone. <i>Do not</i> use on a tone line.	DIALING OPTIONS (<i>4 times</i>)

Call groups

As you set up your autodialer, you may also want to set up *call groups*. These are sets of phone numbers that make it easy to send the same fax to many different locations. For example, one call group may include all of your clients in one city, another group may include all of your employees and another may include all your vendors.

Your fax machine can:

- Store as many as 200 numbers in up to 32 call groups
- Store one number in as many as 32 different groups
- Print a directory of your call groups (see page 2.14)

Using one-touch numbers

Your fax machine stores up to 72 one-touch numbers using the keys marked **01–72**.

Entering or changing a one-touch number

- 1 Press **▶/PROGRAM, A, 1, ENTER**. The LCD shows the empty one-touch number.

Select One-Touch
01:No Number Stored

Note: If a one-touch number other than **01** appears on the LCD, it means that you have already entered a number for **01**.

- 2 Press the one-touch key in which you want to store a number or change a previously stored number. Here, we've selected **02** and the LCD shows either:

Select One-Touch
02:No Number Stored

or

Select One-Touch
02:9-1-555-987-6543

- 3 If you want to select a different one-touch key, press that key now.

- 4 Press **ENTER**. Depending on whether you already have a number entered for this one-touch number, the LCD now shows either:

02:Fax Number
_

or

02:Fax Number
9-1-555-987-6543_

- 5 Use the numeric keypad to enter the number *exactly* as your machine should dial it, including whatever access codes your phone system requires. (You may want to review "Special dialing characters," page 2.7.) The number can be up to 40 characters in length:

02:Fax Number
9-1-5559292039_

Your display can show only 20 characters at a time. To view characters beyond those 20, press **◀** to scroll to the left or **▶/PROGRAM** to scroll to the right.

Note: If want to erase characters, press **CANCEL** to erase to the left. If you want to change just one character in the number, press **◀** to move the cursor left, or **▶/PROGRAM** to move it right. Press **CANCEL** to erase the character. Then re-enter the character correctly.

- 6 When the number is as you want it, press **ENTER** to store it.

- 7 The LCD now displays either:

02:Alt. No.
_

or

02:Alt. No.
9-1-555-987-6553_

You now have the option to enter (or change) an *alternative* number. Your fax machine will dial this alternative number during a transmission or *polling* operation (see pages 2.31–2.33) after all redial attempts to the regular number fail (see page 1.22). If the alternative number also fails, the fax alarm beeps to alert you to a problem.

Note: You can enter one alternative number for one speed-dial or one-touch number you entered. Your fax holds a maximum of 10 alternative numbers in all, that is, only 10 speed-dials or one-touch numbers can have the alternative number. After you have entered the alternative numbers for 10 speed-dials or one-touch numbers, the fax will no longer show this display.

If you want to enter (or change) an alternative number, enter it now.

The number can be up to 40 characters long.

If you *do not* want to enter or change an alternative number, go on to step 8.

- 8 Press **ENTER**.

9 The LCD now displays:

02:Name ;Upper _	or	02:Name ;Upper S. W. Region Office_
---------------------	----	--

The machine is now prompting you for a name — a Location ID — so you'll be able to find it in the EasyDial directory (see page 2.15).

If you *do not* want to enter or change this Location ID, skip to step 11.

If you *do* want to enter or change this Location ID, go on to step 10.

10 Enter the Location ID the same way you entered your fax name during EasyStart. A number's Location ID may be up to 24 characters in length.

Important: As in EasyStart, enter letters and other non-numeric characters by using the one-touch keys.

02:Name ;Upper _

The word "Upper" means the machine is currently set for entering only upper-case letters. If you press **R**, the machine will see it as an *R* (not an *r*).

To enter a lower-case letter, press **ALPHABET**. The display changes to:

02:Name ;Lower _

This means pressing one-touch keys will enter lower-case letters: pressing **R** will produce an *r* (not an *R*) on the display.

To switch back for upper-case entries, press **ALPHABET**.

To enter spaces, punctuation and symbols, use the one-touch keys.

You can also use the **CODE** function to enter characters. Please review the explanation on page 2.2.

Note: To erase characters, press **CANCEL** to erase to the left. To change just one character in the name, press **◀** to move the cursor left, or **▶/PROGRAM** to move it right. Press **CANCEL** to erase the character. Then re-enter it correctly.

11 Press **ENTER** to save the setting and continue.

12 The LCD now displays:

02:Group No. _	or	02:Group No. 2,6_
-------------------	----	----------------------

You may now assign this number to up to 32 call groups. (If necessary, review "Call groups," page 2.8.)

If you *do not* want to change this number's call group, go to step 14.

If you *do* want to change this number's call group, go on to step 13.

13 Use the numeric keypad to enter the call groups for this number. There are 32 possible call groups, numbered 1–32.

Here, we've entered **3** to assign this one-touch number to *Call Group 3*:

02:Group No. 3_

If you want to assign the number to more than one call group, insert a *comma* after each number (except the last one) by pressing **GROUP DIAL**. For example, if you enter **3, GROUP DIAL, 1, 6, GROUP DIAL, 2, 7** to assign this one-touch number to *Call Groups 3, 16 and 27*, the LCD shows:

02:Group No. 3,16,27_

Note: To assign this number to all 32 call groups, enter *0* (zero).

Note: To erase characters, press **CANCEL** to erase to the left. To change just one character in the setting, press **◀** to move the cursor left, or **▶/PROGRAM** to move it right. Press **CANCEL** to erase the character. Then re-enter it correctly.

14 Press **ENTER**.
The LCD will display the next empty one-touch number.
If you *do* want to enter this one-touch number, go back to step 4.
If you *do not* want to enter any more one-touch numbers, press **STOP** to finish.
If you *do not* want to enter the *currently displayed* one-touch number but *do* want to enter *another* one-touch number, go back to step 2.

Use the autodialer labels in your fax's packaging to write down the stored numbers for easy reference. You can also print out a directory of your call groups. See page 2.14.

One-touch *fax* dialing

To dial a *fax* call using a one-touch number:

- 1 Insert the document.
- 2 Adjust resolution and contrast if necessary.
- 3 Toggle between transmission from the feeder or from memory if necessary, by pressing **MEMORY TRANSMIT**.
- 4 Press the one-touch key in which you've stored the number.

What happens next depends on whether you specified transmission from memory or transmission from the feeder:

If you specified Quick Memory transmission:

- Your fax machine scans the first page of your document into memory, then dials the other fax machine.
- While dialing, your machine scans the other documents into memory.
- The LCD shows the Location ID and the document's width and resolution settings:

```
Katz's Cat Care
A4 Normal
```

Note: If the entry doesn't have a Location ID, the number appears.

- When the other machine answers, your fax transmits the scanned document directly from memory. (To review Quick Memory transmission, see page 2.31.)

If you specified normal transmission from memory:

- Your fax machine scans your entire document into memory first, then dials the other fax machine.
- The LCD shows the Location ID and the document's width and resolution settings:

```
Katz's Cat Care
A4 Normal
```

Note: If the entry doesn't have a Location ID, the number appears.

- When the other machine answers, your fax transmits the document directly from memory. (To review memory transmission, see page 1.18.)

If you specified transmission from the feeder:

- Your fax machine dials the other fax machine.
- When the other machine answers, your fax feeds the document through its scanner, transmitting as it goes.
- The LCD shows the Location ID and the document's width and resolution settings:

```
Katz's Cat Care
A4 Normal
```

Note: If the entry doesn't have a Location ID, the number appears.

One-touch *phone* dialing

To dial a *phone* call using a one-touch number, you *must* have an optional handset attached to your machine. (Contact your authorized Muratec dealer to order an optional handset.)

To make the call:

- 1 Obtain a dial tone by doing one of the following:
 - Lift the handset
 - Press **MONITOR/CALL** to use the monitor speaker
- 2 Press the one-touch key in which you've stored the number. As the machine dials, it shows the number on the LCD:

```
** Tel Mode **
9-555-2842_
```

Note: Remember that your fax machine's monitor speaker is *not* a speaker *phone*. If you dialed by using the monitor speaker, pick up the handset to speak to the person that answers.

Note: If the call fails, and you used **MONITOR/CALL** to dial, press **MONITOR/CALL** to hang up.

Erasing a one-touch number

- 1 Press **►/PROGRAM, A, 2, ENTER**. The LCD shows the one-touch number you have already entered:

```
Select One-Touch
01:9-1-555-345-6789
```

Note: If the one-touch number that appears is other than **01**, it means that **01** is empty.

- 2** Press the key for the one-touch number you want to erase. Here, we've selected **02**:

```
Select One-Touch
02:9-1-555-987-6543
```

- 3** If you want to erase a number stored in a different one-touch key than what appears on the LCD, press that key now.

- 4** Press **ENTER**. The LCD shows:

```
Erase One-Touch
Check Program/Enter
```

Important: If you want to quit without erasing the one-touch number you've selected, press **►/PROGRAM**. The fax will return to step 2.

- 5** Press **ENTER** to erase the number.

```
Erase One-Touch
** Complete **
```

To erase another one-touch number, repeat steps 2–5. Or press **STOP** to return to standby mode.

Printing a list of one-touch numbers

Forgot which number is stored in which one-touch key? Just print a list of your one-touch numbers. The list includes each key's number, the Location ID (if any), fax/telephone number and group number(s) you've stored in the key.

To print a list of one-touch numbers, press **►/PROGRAM, A, 3, ENTER**.

Using speed-dial numbers

Your fax machine will store up to 128 speed-dial numbers, designated by three-digit identifier codes from *001* through *128*.

Entering or changing a speed-dial number

- 1** Press **►/PROGRAM, B, 1, ENTER**. The LCD shows an empty speed-dial number:

```
Enter Speed-Dial No.
001:No Number Stored
```

Note: If a speed-dial number other than **001** appears on the LCD, it means you have already entered a number for **001**.

- 2** Use the numeric keypad to enter the desired speed-dial number's three-digit identifier code. Here, we've entered *005* and the LCD shows either:

```
Enter Speed-Dial No. 005:No Number Stored or Enter Speed-Dial No. 005:9-555-397-0123
```

- 3** If you want to select a different speed-dial number, press that number's three-digit identifier code now. That number appears on the LCD.

Important: When entering the identifier code for speed-dial numbers less than 100, you must enter leading zeros to make three digits. For example, *001-099*.

- 4** Press **ENTER**. Depending on whether you already have a number entered for this speed-dial number, the LCD now shows either:

```
005:Fax Number _ or 005:Fax Number 9-555-397-0123_
```

- 5** Use the numeric keypad to enter the speed-dial number *exactly* as your machine should dial it, including whatever access codes your phone system requires. (You may want to review "Special dialing characters," page 2.7.) The number can be up to 40 characters in length:

```
005:Fax Number
9-1-555-567-1234_
```

Your display can show only 20 characters at a time. To view characters beyond those 20, press **◀** to scroll to the left or **►/PROGRAM** to scroll to the right.

Note: To erase characters, press **CANCEL** to erase to the left. To change one character in the number, press **◀** to move the cursor left, or **►/PROGRAM** to move it right. Press **CANCEL** to erase the character. Then re-enter the number correctly.

- 6** When the number appears as you want it, press **ENTER** to store it.

7 The LCD now displays either:

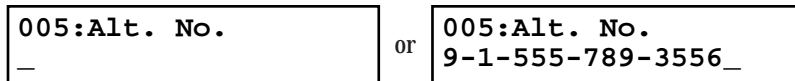

You now have the option to enter (or change) an *alternative* number. Your fax machine will dial this alternative number during a transmission or polling operation (see pages 2.31–2.33) only after redials to the regular number have failed. If the alternative number also fails, the fax alarm beeps to alert you to a problem.

Note: You can enter one alternative number for one speed-dial or one-touch number you entered. Your fax holds a maximum of 10 alternative numbers in all, that is, only 10 speed-dials or one-touch numbers can have the alternative number. After you have entered the alternative numbers for 10 speed-dials or one-touch numbers, the fax will no longer show this display.

If you *do not* want to enter or change an alternative number, skip to step 8. If you *do* want to enter or change an alternative number, use the numeric keypad to do so the same way you did in step 5. This number can be up to 40 characters long

8 Press ENTER.

9 The LCD now displays:

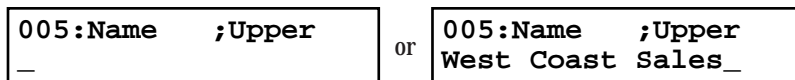

The machine is now prompting you for a name — a Location ID — so you'll be able to find it in the EasyDial directory (see page 2.15).

If you *don't* want to enter or change this number's Location ID, skip to step 11. If you *do* want to enter or change this number's Location ID, go on to step 10.

10 Enter the Location ID the same way you entered your fax name during EasyStart. A number's Location ID may be up to 24 characters in length.

Important: As in EasyStart, enter letters and other non-numeric characters by using the one-touch keys.

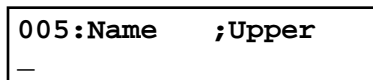

The word "Upper" means the machine is currently set for entering only upper-case letters. If you press **R**, the machine will see it as an *R* (not an *r*).

To enter a lower-case letter, press **ALPHABET**. The display changes to:

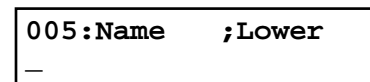

This means pressing one-touch keys will enter lower-case letters: pressing **R** will produce an *r* (not an *R*) on the display.

To switch back for upper-case entries, press **ALPHABET**.

Use the one-touch keypad to enter spaces, punctuation and symbols.

You can also use the **CODE** function to enter characters. Please review the explanation on page 2.2.

Note: To erase characters, press **CANCEL** to erase to the left. To change one character in the name, press **◀** to move the cursor left, or **▶/PROGRAM** to move it right. Press **CANCEL** to erase the character. Then re-enter the name correctly.

11 Press **ENTER** to save the setting and continue.

12 The LCD now displays:

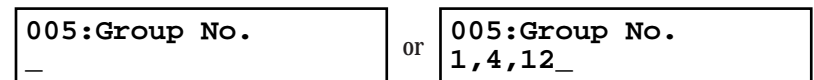

You may now assign this number to up to 32 call groups. (If necessary, review "Call groups," page 2.8.)

If you *do not* want to change this number's call group, skip to step 14. If you *do* want to change this number's call group, go on to step 13.

13 Use the numeric keypad to enter the call groups for this number. There are 32 possible call groups, numbered 1–32.

Here, we've entered **6** to assign this speed-dial number to *Call Group 6*:

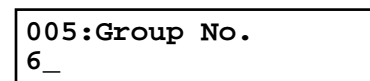

Note: You **do not** have to insert a leading zero for the call group number.

If you want to assign the number to more than one call group, insert a *comma* after each number (except the last one) by pressing **GROUP DIAL**.

Here, we've entered **6**, **GROUP DIAL**, **1,7**, **GROUP DIAL**, **3, 0** to assign this speed-dial number to *Call Groups 6, 17 and 30*:

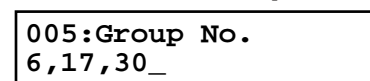

Note: To assign this number to all 32 call groups, enter *0* (zero).

Note: To erase characters, press **CANCEL** to erase to the left. To change just one character, press **◀** to move the cursor to the left, or **▶/PROGRAM** to move it to the right. Press **CANCEL** to erase the character. Then re-enter the setting correctly.

- 14** Press **ENTER**.
The LCD will display the next empty speed-dial number.
If you want to enter this speed-dial number, go back to step 4.
If you *do not* want to enter any more speed-dial numbers, press **STOP** to finish.
If you *do not* want to enter the *currently displayed* speed-dial number but *do* want to enter *another* speed-dial number, go back to step 2.

Fax dialing via speed-dial

To dial a *fax* call using a speed-dial number:

- 1** Insert the document.
- 2** Adjust resolution and contrast if necessary.
- 3** Toggle between transmission from the feeder or from memory if necessary, by pressing **MEMORY TRANSMIT**.
- 4** Press **SPEED DIAL/TEL INDEX**. The LCD shows:

```
Enter Speed-Dial No.
S_
```

- 5** Use the numeric keypad to enter the three-digit identifier (such as *018*, in this example) for the speed-dial number you want to dial. The LCD shows:

```
Shipping & Receiving
S018_
```

- 6** Press **START**.

What happens next depends on whether you specified transmission from memory or transmission from the feeder:

If you specified quick memory transmission:

- Your fax machine scans the first page of your document into memory, then dials the other fax machine.
- While dialing, your machine scans the other documents into memory.
- The LCD shows the Location ID and the document's width and resolution settings:

```
Shipping & Receiving
A4 Normal
```

Note: If the entry doesn't have a Location ID, the number appears.

- When the other machine answers, your fax transmits the scanned document directly from memory. (To review quick memory transmission, see page 2.31.)

If you specified normal transmission from memory:

- Your fax machine scans your entire document into memory, then dials the other fax machine.
- The LCD shows the Location ID and the document's width and resolution settings:

```
Shipping & Receiving
A4 Normal
```

Note: If the speed-dial entry doesn't have a Location ID, the number appears.

- When the other machine answers, your fax will transmit the document directly from memory. (To review memory transmission, see page 1.18.)

If you specified transmission from the feeder:

- Your fax machine dials the other fax machine.
- When the other machine answers, your fax feeds the document through its scanner, transmitting as it goes.
- The LCD shows the Location ID and the document's width and resolution settings:

```
Shipping & Receiving
A4 Normal
```

Note: If the speed-dial number doesn't have a Location ID, the number appears.

Phoning via speed-dial

To dial a *phone* call using a speed-dial number, you *must* have an optional handset attached to your machine. To make the call:

- 1** Obtain a dial tone by doing one of the following:
 - Lift the handset
 - Press **MONITOR/CALL** to use the monitor speaker

- 2** Press **SPEED DIAL/TEL INDEX**. The LCD shows:

```
** Tel Mode **
S_
```

- 3** Use the numeric keypad to enter the three-digit identifier (such as *018*, in this example) for the speed-dial number you want to dial. The LCD shows:

```
** Tel Mode **
9-555-5783_
```

Note: Remember that your fax machine's monitor speaker is *not* a speakerphone. If you dialed using the monitor speaker, pick up the handset to speak to the person that answers!

Note: If the call fails, and you used MONITOR/CALL to dial, press MONITOR/CALL to hang up.

Erasing a speed-dial number

- 1 Press ►/PROGRAM, B, 2, ENTER. The LCD shows the speed-dial number you have already entered:

```
Enter Speed-Dial No.
001:9-555-584-6950
```

Note: If the speed-dial number that appears is other than 001, it means that 001 is empty.

- 2 Use the numeric keypad to enter the three-digit identifier for the speed-dial number you want to erase. Here, we've selected 005:

```
Enter Speed-Dial No.
005:9-1-555-987-6543
```

- 3 If you want to erase a different speed-dial number than the one that appears on the LCD, enter that number now.

- 4 Press ENTER. The LCD shows:

```
Erase Speed-Dial
Check Program/Enter
```

Important: If you want to quit without erasing the speed-dial number you've selected, press ►/PROGRAM. The fax will return to step 2.

- 5 Press ENTER to erase the number.

```
Erase Speed-Dial
** Complete **
```

To erase another speed-dial number, repeat steps 2–5. Or press STOP to return to standby mode.

Printing a list of speed-dial numbers

You can easily print a list of your speed-dial numbers. The list includes each number's three-digit identifier, the Location ID (if any), number and any group numbers you've stored for that speed-dial number.

To print a list of speed-dial numbers, press ►/PROGRAM, B, 3, ENTER.

Printing a call group directory

Your machine can also print a *call group directory*. (If necessary, review “Call groups,” page 2.8.) This lists all your stored autodialer numbers by Location ID and lists the groups to which these numbers belong.

The directory divides the call groups into four banks, 01–09 (the list shows 00), 10–19 (the list shows 10), 20–29 (the list shows 20) and 30–32 (the list shows 30). If you specify call group 0 (which puts the number in all call groups), the directory shows all numbers (see below).

For example, the directory might show:

No.	Location	00	10	20	30
S001	And Sew I	2 4			
S002	KC Enterp	7	0	1	
S003	Katz Cat			0	2
[01]	Carson Co	4	0 4		
[02]	Tex. Ofc.	1			
[03]	e.e.gummi	1 2 3 4 5 6 7 8 9	0 1 2 3 4 5 6 7 8 9	0 1 2 3 4 5 6 7 8 9	0 1 2

In this list, speed-dial number 001 (S001) is in call groups 2 and 4; speed-dial number 002 (S002) is in groups 7, 10 and 21; speed-dial number 003 (S003) is in groups 20 and 32; one-touch number 01 ([01]) is in groups 4, 10 and 14; one-touch number 02 ([02]) is in group 1; and one-touch number 03 ([03]) is in all groups, 1 to 32.

To print a call group directory, press ►/PROGRAM, H, ENTER.

EasyDial directory dialing

EasyDial directory dialing makes your autodialer even more like an electronic phone book. EasyDial sorts and displays numbers alphabetically according to their Location IDs, so you can find them and dial them easily.

To dial using EasyDial:

- 1** For a regular phone call: *Make sure there's no document in the feeder*, then skip to step 4.
For a fax call: Insert the document.
- 2** Adjust resolution and contrast if necessary.
- 3** If you want to toggle between transmission from memory and transmission from the feeder, press **MEMORY TRANSMIT**.
- 4** Press **SPEED DIAL/TEL INDEX** *twice*. The LCD shows the *first* listing in your fax machine's EasyDial directory:

Telephone Index [A] ABC Company : [01]

The EasyDial directory sorts entries alphabetically in the following order: (1) by alphabet, (2) by number and (3) by symbol.

If the listing that appears is the one you want to dial, skip to step 6.

- 5** Scroll through the listings to find the one you want. You do this by pressing the following keys on the numeric keypad:
 - **2** or **8** to select the character set — alphabet, number or symbol — for the *first* character of the Location ID.
 - **4** or **6** to check different listings within that character set.

Note: The scrolling is “open-ended.” For example, when you run out of listings beginning with alphabet “A”, pressing **4** or **6** automatically moves you into listings beginning with other characters.

- 6** When the LCD displays the name you want to dial, press **START**.
 - If there *is* a document in the feeder, your machine will dial a *fax call*.
 - If there *isn't* a document in the feeder, your machine will activate the monitor speaker and dial a regular phone call. At this point, you may either:
 - Lift the handset now
 - or*
 - Listen to the monitor speaker until you hear the other person answer, and then lift the handset.

To make a regular phone call from your machine, you must have an optional handset attached.

If an EasyDial call fails

If an EasyDial call fails, what happens next depends upon the kind of call it was.

If it was a fax call ...

... Your fax machine automatically redials the number according to the redial interval you've set (see page 1.22). It keeps trying until either of the following occurs:

- It successfully reaches the other number
- It has attempted the number of redials programmed and has still not connected (see “Changing redial settings,” page 1.22).

If it was a regular phone call ...

... You'll have to redial manually:

- 1** Obtain a dial tone by **either** lifting the handset or pressing **MONITOR/CALL**.
- 2** Press **REDIAL/PAUSE**.

Note: If the call fails and you used **MONITOR/CALL** to dial, press **MONITOR/CALL** to hang up. Or if you've pressed **START** to begin the transmission, press **STOP** to end it.

Broadcasting

Broadcasting basics

The fastest way to fax *one* document to *many* recipients is to *broadcast* it.

In an ordinary broadcast, you send the fax as you normally would, except you just add more fax numbers. You can enter up to 230 numbers:

- 30 manually-dialed numbers **AND**
- 200 autodialer numbers **OR** 1 call group with all 200 autodialer numbers

You can broadcast using any function that requires a fax number to be entered. That means you can send a *delayed* broadcast, program a *polling* broadcast and even broadcast to “hub” units for F-Code *relay broadcast initiation*. All of these are explained in this chapter.

To send a broadcast fax:

- 1** Insert the document and make any necessary adjustments as you would for a regular fax transmission.
- 2** Press **BROADCAST**.
- 3** Enter the *first* fax number, as usual. Use either a one-touch number, a speed-dial number, a call group or a regular number dialed from the numeric keypad.
- 4** To add more fax numbers, press **BROADCAST** between each one to insert a *comma*. Then enter the number as described in step 3 (**GROUP DIAL** inserts its own comma). You can send to up to 230 numbers for a broadcast.

```
Press Start
[03],S098,[10],9-555
```

Important: Do **not** insert a comma after the *last* fax number.

Note: If you enter characters by mistake, press **CANCEL** to erase them.

- 5** Press **START**. Your fax machine scans the document into memory and then sends it to each number or call group you've entered.

Delayed broadcasting

What if you want the broadcast to take place later? That's the purpose of setting up a *delayed broadcast*.

Note: Delayed commands are discussed in detail later. You may want to read “Delayed transmission” on page 2.17 before proceeding.

- 1** Follow steps 1–4 of “Broadcasting basics” (left column).
- 2** Press **COM-OPTIONS**, **ENTER**.
- 3** Use the numeric keypad to enter the day of the month and time (in 24-hour format) when you want the broadcast to occur. Here, we've scheduled it for 10:15 PM on the 30th.

```
Delayed
Enter Time: 30/22:15
```

When finished, press **ENTER** to save the setting.

- 4** Press **START**. Your machine will return to standby mode, while showing this on the LCD:

```
** Reserved **
Jan 29 2000 17:17
```

This means your fax machine is “reserved” for the delayed broadcast you just programmed, but it can still be used to send and receive faxes if your broadcast document is stored in memory.

Making changes to broadcasts

If you need to make changes in a broadcast after setting it up, use the **REVIEW COMMANDS** function. See “Reviewing or cancelling parts of a broadcast,” page 2.18.

Delayed transmission

Take advantage of lower evening and weekend long-distance rates with *delayed transmission*. Your fax machine can store up to 99 delayed commands, each of which you can program up to 31 days in advance.

Important: If you program all 99 delayed transmission commands, no further *memory* transmission is possible until one or more of the commands is completed. (To review memory transmission, see page 1.18.) However, if all 99 delayed commands are programmed, you can always transmit manually using monitor/speaker dialing or an optional handset (see page 1.21).

Setting up a delayed transmission

Important: Your machine only remembers the *day* of the month that it's supposed to send a delayed transmission. It does not remember the month itself. So if you want to send a transmission at 5:05 PM on **June** 26, don't program the transmission sooner than 5:06 PM on **May** 26.

To set up a delayed transmission:

- 1 Insert the document and make any necessary adjustments.
- 2 Press **COM-OPTIONS**. The LCD shows:

1.Delayed
Program/Enter
- 3 Press **ENTER**. The LCD shows the current day of the month, followed by the current time (in 24-hour format):

Delayed
Enter Time: 06/17:16
- 4 Use the numeric keypad to enter the day of the month and the time when you want the fax to send the delayed transmission.

Note: Press **◀** to move the cursor left, or **▶/PROGRAM** to move it right.

Here, we've set the transmission to occur on the 11th at 11:05 PM:

Delayed
Enter Time: 11/23:05

- 5 When the date and time are entered, press **ENTER** to save the delayed transmission. The LCD shows:

Enter Fax Number
—

- 6 Enter the fax number for the delayed transmission document. You can either press a one-touch key, enter a speed-dial number or use the numeric keypad to enter the fax number.

Note: If you want to erase characters, press **CANCEL** to erase to the left. If you want to change just one character in the number, press **◀** to move the cursor left, or **▶/PROGRAM** to move it right. Press **CANCEL** to erase it. Then re-enter the number correctly.

- 7 Press **START**. Your machine returns to standby mode, while showing this on the LCD:

**** Reserved ****
Jan 29 2000 17:17

This means your fax machine is “reserved” for the delayed transmission you just programmed.

- If you set the machine for *memory transmission*, it will scan the document into memory, after which you can use the machine normally.
- If you set the machine for *manual transmission*, the machine can *receive* faxes but can't *transmit* until your delayed command has been performed.

Important: If you've stored too much information in your machine's memory, a “Memory Overflow” message may appear on the LCD. This appears because (1) too many pages have been stored in the memory, or (2) the pages that are stored have too much information on them for your fax machine to remember.

If this message appears, press **START** to tell your fax to keep as many pages in memory as possible, or press **CANCEL** to delete from memory all pages stored during the current operation (but not previous operations).

Reviewing or canceling delayed commands

If you've stored a delayed command in your fax machine, it will hold it in memory until it either completes the command successfully or reaches its maximum number of redial attempts (see page 1.22). Your machine can store up to 99 delayed commands. It identifies each by a two-digit *command number* ranging from 01 to 99.

To see your machine's stored commands or to cancel them:

- 1 Press REVIEW COMMANDS.
 - **If there are no stored commands in your machine** — It beeps briefly and displays "No Command" on the LCD. It then returns to standby mode.
 - If there *are* commands in your machine's memory, the LCD shows:

```
C01:9-5552311
  Program/Cancel
```

Here, you see *command 01*, followed by the number it's set to dial. If the command is to send a *broadcast*, "Broadcast" appears instead of the phone number. (See "Broadcasting," page 2.16.)

If the command is to send a *batch transmission*, the LCD shows its *batch box number* (such as "B01") rather than the command number. (See "Batch transmission," pages 2.20–2.23.)

If the command is for a *continuous polling operation*, the LCD shows its *continuous polling operation number* (such as "P01") rather than the command number. (See "Polling," on pages 2.31–2.33.)

Note: If your machine is attempting to perform a command *now*, it appears on the display.

- 2 Press ►/PROGRAM or ◀ to scroll through currently stored commands.
- 3 If you want to cancel the command shown, press CANCEL. The LCD shows:

```
C01:9-5552311
  Check Program/Cancel
```

- 4 To *keep* this command but to continue reviewing stored commands, press ►/PROGRAM. Go back to step 2. To keep this command *and* stop reviewing commands, press STOP to return your machine to standby mode. To go ahead with cancelling the command, press CANCEL again. Go back to step 2 to view other delayed commands.

Note: See also "Reviewing or cancelling parts of a broadcast," next column.

Reviewing or cancelling parts of a broadcast

You also can review or cancel certain numbers within a broadcast:

- 1 Press REVIEW COMMANDS.
- 2 Press ►/PROGRAM or ◀ to scroll through currently stored commands.

Note: Stop this operation at any time by pressing STOP.
- 3 If you want to cancel the command shown, press CANCEL, CANCEL. If you want to review *individual* numbers within this broadcast, go on to step 4 *without* pressing CANCEL.
- 4 To review *individual* numbers within this broadcast, press BROADCAST to see the first number. The LCD shows:

```
9-5550388
  Program/Cancel
```
- 5 Press ►/PROGRAM or ◀ until you find the number you want to cancel.
- 6 Press CANCEL, CANCEL. The next number will appear. If you want to cancel this number, also, repeat this step. If you want to cancel a different number, go back to step 5. If you don't want to cancel any more numbers, press STOP. The machine returns to standby mode.

Printing a delayed command list

Your machine can print a *command list* which tells you:

- The command's identification number
- The phone number, or "remote location"
- The start time (this appears in a *DD,HH:MM* format)
- A "note" telling if the command is a *polling* or *F-Code* operation (see pages 2.31–2.33 for more on *polling* and 2.38–2.47 for more on *F-Code communication*).

To print a delayed command list, press ►/PROGRAM, F, 1, ENTER.

Printing a stored document

Your fax machine can print out each document stored for delayed transmission. To print a stored document, you'll need to know the document's command number, which you can get by either reviewing the commands (see page 2.18) or printing a delayed command list (see above).

- 1 Press ►/PROGRAM, F, 2, ENTER. The LCD shows:

```
Print Stored Doc.
Command No.   :_
```

- 2 Use the numeric keypad to enter the command's identification number, *01–99*. For example, we could enter the following for the very first command, *01*:

```
Print Stored Doc.
Command No.   :01_
```

- 3 Press ENTER. Your fax machine will print a copy of the stored document.

Batch transmission

Batch transmission allows you to store multiple documents in an electronic “basket” throughout the day and then fax that entire basket to *one* location.

To do this, just tell the machine when and where the transmission should go. When that date and time arrives, your machine will transmit each document in the batch box to the remote fax machine. You can store up to 40 documents (each document can include one page or many pages) into your machine’s five electronic *batch boxes*.

Creating or modifying a batch box

Before sending a batch transmission, you have to create batch boxes in your fax machine. The steps below also let you modify existing batch boxes.

To create or modify a batch box:

- 1** Press **►/PROGRAM, N, 1, ENTER**. Depending on whether you already have a number entered for batch box *1*, the LCD shows:

Select Batch Box
1:No Number Stored

or

Select Batch Box
1:9-1-555-345-6789

- 2** Use the numeric keypad to enter the number (*1-5*) of the batch box you want to create or modify. Here, we’ve pressed **3** and see either:

Select Batch Box
3:No Number Stored

or

Select Batch Box
3:9-555-2110

- 3** If you want to select a different batch box than the one displayed on the LCD, use the numeric keypad to enter the batch box number now.

- 4** Press **ENTER**. The LCD now shows either:

3:Fax Number
_

or

3:Fax Number
9-555-2110_

- 5** Use the numeric keypad to enter the fax number *exactly* as your machine should dial it, including whatever access codes your phone system requires. (You may want to review “Special dialing characters,” page 2.7.) The number can be up to 40 characters in length:

3:Fax Number
9-1-555-871-9052_

Your display can show only 20 characters at a time. To view characters beyond those 20, press **◀** to scroll to the left or **►/PROGRAM** to scroll to the right.

Note: To erase characters, press **CANCEL** to erase to the left.

To change just one number, press **◀** to move the cursor left, or **►/PROGRAM** to move it right. Press **CANCEL** to erase it. Then re-enter the number correctly.

- 6** When the number appears as you want it, press **ENTER**. The LCD now displays:

3:Transmit Time
Enter Time: 26/14:00

- 7** Instruct your fax to send from this batch box in *one* of the following ways:

Option 1: *Once* at a certain time on a certain day of the month (*For example:* “Do this at 5:05 PM on the 30th.”) — Use the numeric keypad to enter the date and time (*24-hour format*) the machine should send the documents from the batch box:

3:Transmit Time
Enter Time: 30/17:05

Option 2: At a certain time *each day you press the key* (*For example:* “Do this at 5:05 PM today.”) — Use the numeric keypad to enter **0, 0** (*00*), and then the time when the fax should send the documents from the batch box:

3:Transmit Time
Enter Time: 00/17:05

Note: To change a digit in the date or the time, press **◀** to move the cursor left or **►/PROGRAM** to move it right. Then enter the correct number.

- 8** When the date and time are set, press **ENTER**.

- 9** The LCD now displays:

3:Name ;Upper
_

or

3:Name ;Upper
Bookkeeping_

The machine now asks you to name this batch box.

If you *do not* want to enter or change this batch box’s name, skip to step 11.

- 10** Enter the name the same way you entered your fax name during EasyStart. A batch box's name may be up to 24 characters in length.

Important: As in EasyStart, enter letters and other non-numeric characters by using the one-touch keys.

3 : Name ; Upper
_

The word "Upper" means the machine is currently set for entering only upper-case letters. If you press **R**, the machine will see it as an *R* (not an *r*).

To enter a lower-case letter, press **ALPHABET**. The display will change to:

3 : Name ; Lower
_

This means pressing one-touch keys will enter lower-case letters: pressing **R** will produce an *r* (not an *R*) on the display.

To switch back for upper-case entries, press **ALPHABET**.

Use the one-touch keypad to enter spaces, punctuation and symbols.

You can also use the **CODE** function to enter characters. Please review the explanation on page 2.2, if necessary.

Note: To erase characters, press **CANCEL** to erase to the left. To change just one character in the name, press **◀** to move the cursor left, or **▶/PROGRAM** to move it right. Press **CANCEL** to erase it. Then re-enter the name correctly.

- 11** Press **ENTER** to save the batch box information.

To create or modify another batch box, repeat steps 2–11. To finish, press **STOP**.

Printing a list of batch boxes

You can easily print a list of your batch boxes. The list includes each box's identifier number, the Location ID, fax number and date/time the transmission should start.

To print the list, press **▶/PROGRAM, N, 2, ENTER**.

Storing a document for batch transmission

Your fax machine can store up to 40 *documents* (each document can include one page or many pages) in each batch box until the date and time you designate the batch transmission to take place. Once the batch documents are transmitted, they are automatically erased from the machine's memory.

Note: For this operation to work, two things must be true:

- The batch box must exist on your fax machine.
- You must know the batch box's one-digit number (1–5).

To store a document in a batch box for batch transmission:

- 1** Insert the document and make any necessary adjustments.
- 2** Press **COM-OPTIONS** *three* times and then press **ENTER**. The LCD shows:

Batch Tx
Enter Box No. _

- 3** Use the numeric keypad to enter the one-digit number for the batch box you want to use. Here, we've entered **5** to indicate batch box 5.

Batch Tx
Enter Box No. 5_

Note: *Tx* is a common abbreviation for *transmission*.

- 4** Press **ENTER**. The LCD shows:

Press Start
Box: 5 File: 01

Important: Your machine gives each document in a batch box a *file number*, shown as *01* above. You will need to know this file number should you later wish to erase or print the stored document. Each batch box holds up to 40 files (01–40).

- 5** Press **START**. The machine displays "Reserved" on the top line of the LCD. This means the document is stored in memory.

Printing a list of stored batch documents

You can print a list of the documents stored in your machine's batch boxes. This list provides you with the documents' file numbers so you can erase or print them as needed.

To print the list, press **▶/PROGRAM, N, 3, ENTER**.

Printing a document stored in a batch box

To print a document stored in a batch box:

- 1 Press **▶/PROGRAM, N, 4, ENTER**. The LCD shows:

```
Print Batch Doc.
Enter Box No.   _
```

- 2 Use the numeric keypad to enter the number (1-5) of the batch box storing the document you want to print.

- 3 Press **ENTER**. The LCD shows:

```
Print Batch Doc.
Enter File No.  _
```

- 4 Use the numeric keypad to enter the document's *two-digit* file number (01-40). If the file number is 01-09, be sure to enter the leading zero.

- 5 Press **ENTER**.

Your fax machine prints the document, then returns to standby mode.

Erasing a document stored in a batch box

To erase a document stored in a batch box on your fax machine:

- 1 Press **▶/PROGRAM, N, 6, ENTER**. The LCD shows:

```
Erase Batch Doc.
Enter Box No.   _
```

- 2 Use the numeric keypad to enter the number (1-5) of the batch box storing the document you want to erase.

- 3 Press **ENTER**. The LCD shows:

```
Erase Batch Doc.
Enter File No.  _
```

- 4 Use the numeric keypad to enter the document's *two-digit* file number (01-40). If the file number is 01-09, be sure to enter the leading zero.

- 5 Press **ENTER**. The fax machine now gives you one last chance to change your mind before erasing the document.

```
Erase Batch Doc.
Check   Enter/Stop
```

Important: To quit the operation without erasing this or any document, press **STOP**. The machine returns to standby mode.

- 6 Press **ENTER**. The fax machine erases the document you've chosen, then returns to standby mode.

Erasing an empty batch box

Batch boxes must be empty to be erased. If a box has documents stored in it, then you first have to erase those documents. See page 2.22.

To erase an empty batch box:

- 1** Press ►/PROGRAM, N, 5, ENTER. The LCD shows:

Select Batch Box 1:No Number Stored	or	Select Batch Box 1:9-5551023
--	----	---------------------------------

- 2** Use the numeric keypad to enter the number (1-5) of the batch box you want to erase. Here, we've pressed 2 and see:

Select Batch Box 2:9-1-972-5559900

- 3** If you want to erase a different batch box than what appears on the LCD, enter that batch box's number now.

- 4** Press ENTER. If the batch box is empty, the LCD shows:

Erase Batch Box Check Program/Enter
--

Important: If you select a batch box which is *not* empty, the machine beeps and briefly displays:

Select Batch Box Document Stored

Erase any documents stored in the batch box (see page 2.22), then go back to step 3.

Important: If you want to quit without erasing the batch box you've selected, press ►/PROGRAM. The fax will return to step 2.

Important: If you want to quit without erasing *any* batch box, press STOP. The machine returns to standby mode.

- 5** Press ENTER to erase the batch box.

Erase Batch Box ** Complete **

To erase another batch box, repeat steps 2-5. To finish, press STOP.

Special features

Your fax machine has numerous special features to make your communication easier. We'll cover them here.

Soft Keys

Soft Keys are shortcut keys. You can program the soft keys on the control panel to turn on or off any function with just the touch of a button. Your machine has three Soft Keys. If the light above any one of these keys glows, that means the setting programmed into that key is active.

These keys are programmed at the factory to turn the following functions on or off:

- Confirmation stamp (see page 2.5)
- Confirmation report (see page 2.30)
- Memory transmission (see pages 1.18)

Note: The keys that are programmed at the factory turn the functions above them on and off, but only for the next transmission that you send from your fax machine. Once that transmission is complete, your machine returns to its default setting.

But instead of using the Soft Keys to control the functions above, you can program them to turn other functions on or off. These functions are:

- Send TTI (see "Getting Started," page 1.15)
- Cover page (see page 2.28)
- Flash — Lets you quickly disconnect a call and go right to the next one without having to hang up the handset.

Note: And instead of just turning the function on or off for the next transmission, as the factory-set keys do, changing the Soft Key settings actually sets the default for your fax machine. (These default settings can be changed, if necessary. They are not permanent.)

Setting the Soft Key

- 1** Press **▶**/PROGRAM, E, ENTER. The LCD shows:

```
Select Soft Key No.  
1:Stamp
```

... or indicates another function you've stored into this key.

- 2** Press **◀** or **▶**/PROGRAM until the Soft Key (1-3) you want to change appears. In this example, we've chosen **3**.

- 3** Press ENTER. The LCD shows:

```
3:Memory Tx  
Program/Enter
```

- 4** Press **◀** or **▶**/PROGRAM until the function appears that you want to program into the key. In this example, we've chosen *Cover page*.

```
3:Cover page  
Program/Enter
```

- 5** Press ENTER to save the setting. The LCD will display the next Soft Key. If you *do* want to set this Soft Key, go back step 3. If you *do not* want to set the currently displayed Soft Key but do want to set another Soft Key, go back to step 2. If you *do not* want to set any more Soft Keys, press **STOP** to finish.

Now you can use the labels included in your machine's original packaging to label the Soft Key function you just set.

Macros

In order to complete some operations on your machine, you may have to follow several steps and press several different buttons. But programming your machine's *Macro keys (MACRO 1 – MACRO 3)* can reduce those many steps to a simple press of a key. You can “teach” the Macro keys to carry out any of the following jobs:

Note: One Macro key can hold only one job. It cannot combine two or more jobs.

Copy:

- Copy settings (Number of copies, Paper size, Sort on/off, Resolution, Contrast and Enlargement/Reduction) (pages 1.28–1.29)

Printouts:

- One-touch numbers list (pages 2.11)
- Speed-dial numbers list (pages 2.14)
- Programmable one-touch numbers list (pages 2.55)
- Delayed commands list (pages 2.19)
- Activity journal (pages 2.29)
- Call group directory (pages 2.14)
- Machine settings list (pages 2.6)
- Sample cover page (pages 2.28)
- Department time list (pages 2.63)
- Batch box list (pages 2.21)
- List of stored batch documents (pages 2.21)
- List of transfer pattern (pages 2.37)
- List of F-Code boxes (pages 2.42)
- List of documents stored in F-Code boxes (pages 2.42)
- Stored polling documents (pages 2.33)
- Delayed commands documents (pages 2.19)
- Security receive documents (pages 2.57)
- Batch transmission documents (pages 2.21)
- F-Code Box (bulletin box) documents (pages 2.43)

Document storage:

- Regular polling documents (pages 2.31)
- F-Code polling documents (pages 2.42)

Communications functions:

- Delayed transmission (explained on pages 2.17–2.19)
- Regular polling (page 2.31)
- Continuous polling (pages 2.32)
- Batch transmission (pages 2.20–2.23)
- F-Code transmission (pages 2.46–2.47)
- F-Code polling (page 2.47)

Programming the Macro key

1 Press **MACRO PROGRAM, ENTER**. The LCD shows:

```
Select Macro Key
M1:No Number Stored
```

2 Press the Macro key (**MACRO 1 – MACRO 3**) you want to program or change. In this example, we've chosen **MACRO 2**.

```
Select Macro Key
M2:No Number Stored
```

3 Press **ENTER**. If you chose the key already programmed, proceed to step 4. Otherwise, skip to step 5.

4 The LCD shows:

```
Overwrite?
Check Program/Enter
```

If you want to overwrite the operation already programmed, press **ENTER**. If you want to overwrite only the job's name, press **PROGRAM** and go to step 9. If you *do not* want to overwrite the key you have choiced, press **STOP**.

5 The LCD of stand-by mode appears, which means the machine is ready to register the steps into the Macro key.

```
Fax Ready
Jan 11 2000 13:30
```

Note: It keeps beeping during the job registration in order to make notice of the registration mode.

6 Press the keys exactly as you operate the job you want to program into the Macro key.

Note: You can program up to 60 steps. When it comes over 60 steps, your fax machine asks if you register the operations you have entered. If you want to register them, press **ENTER**. If not, press **STOP**.

Note: If you want to cancel the operations you have set, press **MACRO PROGRAM**, **STOP** and then go back to step 1.

Example 1: To program some operations for copy: Press **COPY/FAX**, and set number of the copies, paper size, contrast, resolution, reduction/enlargement rate and sort setting as you want.

Note: See “Making copies” (pages 1.28–1.31) for detail operations.

Example 2: To program the operations for printing the one-touch numbers list: Press **►/PROGRAM**, **A**, **3**, **ENTER**.

7 If you programmed **ENTER** or **START** into the operation, proceed to step 8. Otherwise, press **MACRO PROGRAM** and skip to step 9.

8 If you want to start immediately after pressing the Macro key when you use it, press **ENTER**. If not, press **►/PROGRAM**.

Note: If you want to confirm the settings or operations in the Macro key before you start it, press **►/PROGRAM** here.

Include Start/Enter
Check Program/Enter

9 The LCD now displays:

M2:Macro Name ;Upper
—

or

M2:Macro Name ;Upper
Delayed_

The machine now asks you to name this job.

If you *do not* want to enter or change this job's name, skip to step 11.

10 Enter the name the same way you entered your fax name during EasyStart. A job's name may be up to 130 characters in length.

Important: As in EasyStart, enter letters and other non-numeric characters by using the one-touch keys.

M2:Macro Name ;Upper
—

The word “Upper” means the machine is currently set for entering only upper-case letters. If you press **R**, the machine will see it as an *R* (not an *r*).

To enter a lower-case letter, press **ALPHABET**. The display will change to:

M2:Macro Name ;Lower
—

This means pressing one-touch keys will enter lower-case letters: pressing **R** will produce an *r* (not an *R*) on the display.

To switch back for upper-case entries, press **ALPHABET**.

Use the one-touch keypad to enter spaces, punctuation and symbols.

You can also use the **CODE** function to enter characters. Please review the explanation on page 2.2, if necessary.

Note: To erase characters, press **CANCEL** to erase to the left. To change just one character in the name, press **◀** to move the cursor left, or **►/PROGRAM** to move it right. Press **CANCEL** to erase it. Then re-enter the name correctly.

11 Press **ENTER** to save the setting. To program or modify another job, repeat steps 2–11. To finish, press **STOP**.

Copying with the Macro key

To copy using a Macro key:

- 1** Insert the document.
- 2** Press the Macro key in which you've stored the copy command.
- 3** Press **START**, if you have not registered **START** in the Macro key.

Printing lists using the Macro key

To print a list using a Macro key:

Press the Macro key in which you've stored the list operation you want to print.

Storing fax documents with the Macro key

To store a fax document for either polling or F-Code polling using a Macro key:

- 1** Insert the document.
- 2** Press the Macro key which is programmed for the storing operation you want to use.
- 3** Press **ENTER**, if you have not registered **ENTER** in the Macro key.

Fax dialing with the Macro key

To dial a fax call using a Macro key:

- 1 Insert the document.
- 2 Press the Macro key in which you've stored the fax communication command.
- 3 Press **START**, if you have not registered **START** in the Macro key.

Your fax will perform the operation now, or at whatever time you programmed.

If you programmed this key to delay its operation, the LCD shows:

```

** Reserved **
Jan 29 2000 17:17
  
```

If you programmed this key to perform the operation immediately after you press it, the LCD shows the number:

```

9-1-972-555-4335
A4 Normal
  
```

Erasing a Macro key

- 1 Press **MACRO PROGRAM** twice, **ENTER**. The LCD shows:

```

Select Macro Key
M1:Activity journal
  
```

- 2 Press the Macro key (**MACRO 1** – **MACRO 3**) you want to erase. Here, we've chosen **MACRO 2**.

```

Select Macro Key
M2:Batch box list
  
```

- 3 Press **ENTER**. The LCD shows:

```

Erase Macro
Check Program/Enter
  
```

Important: If you want to quit without erasing the Macro key you've selected, press **▶/PROGRAM**. The fax will return to step 2.

- 4 Press **ENTER** to erase the job.

```

Erase Macro
** Complete **
  
```

To erase another Macro key, repeat steps 2–4. Or press **STOP** to return to standby mode.

Printing a list of your Macro keys

Your fax machine can print a list of the Macro keys.

The list includes:

- (1) each key's Macro key number
- (2) the name of the job stored in the Macro key

To print a list of Macro keys, press **MACRO PROGRAM** three times, **ENTER**.

Setting the speed for Macros

You can adjust the speed of one step in the Macro key.

- 1 Press **MACRO KEY** four times, **ENTER**. The LCD shows:

```

Macro Speed :Norm
Program/Enter
  
```

- 2 Press **◀** or **▶/PROGRAM** until the mode you want appears. The possible settings are:

```

Macro Speed :Norm
Program/Enter
  
```

```

Macro Speed :Slow
Program/Enter
  
```

```

Macro Speed :Fast
Program/Enter
  
```

- 3 Press **ENTER** to save the setting.

Cover page

Your fax machine can store a *cover page* to send at the beginning of each outgoing fax. This page includes the current date and time, your Location ID and your fax number (as stored in the TTI) and a message of up to 40 characters in length. The information appears in a box similar to this:

Fax Message From:	
Jan 11 2000 14:00	
Name:	And Sew It Goes Co.
Fax Number:	972-555-2009
[We appreciate your business. Thank you!]	

Turning the cover page on

- 1 Press **▶/PROGRAM, K, 1, ENTER**. The LCD shows:

Cover Page	:Off
Program/Enter	

- 2 To tell the fax machine it *should* send a cover page before each document you transmit, press **◀** or **▶/PROGRAM** until "On" appears on the LCD.

Cover Page	:On
Program/Enter	

Note: To tell the machine not to send a cover page, press **◀** or **▶/PROGRAM** until "Off" appears on the LCD and press **STOP**.

- 3 Press **ENTER** to save the setting.

Now the cover page feature is working but your message line (shown in the example as "We appreciate your business. Thank you!") is blank. To enter that message, see "Entering the cover page message," next column.

Entering the cover page message

- 1 Press **▶/PROGRAM, K, 2, ENTER**.
- 2 Use the one-touch keypad to enter a message for the cover page. Enter the message the same way you entered your fax name during EasyStart. The message can be up to 40 characters in length.
Important: As in EasyStart, enter letters and other non-numeric characters by using the one-touch keys.

Cover Page ;Upper
—

The word "Upper" means the machine is currently set for entering only upper-case letters. If you press **R**, the machine will see it as an *R* (not an *r*).

To enter a lower-case letter, press **ALPHABET**. The display will change to:

Cover Page ;Lower
—

This means pressing one-touch keys will enter lower-case letters: pressing **R** will produce an *r* (not an *R*) on the display.

To switch back for upper-case entries, press **ALPHABET**.

Use the one-touch keypad to enter spaces, punctuation and symbols.

You can also use the **CODE** function to enter characters. Please review the explanation on page 2.2.

Note: To erase characters, press **CANCEL** to erase to the left. To change just one character in the message, press **◀** to move the cursor left, or **▶/PROGRAM** to move it right. Press **CANCEL** to erase it. Then re-enter the message correctly.

- 3 When the message appears as you want it, press **ENTER** to save it.

Printing the cover page

To confirm that the cover page is set correctly, print a sample cover page from your fax machine. Press **▶/PROGRAM, K, 3, ENTER**.

Setting the activity journal

Just as a checkbook records your daily financial transactions, your fax machine keeps an *activity journal* which records its 100 most recent fax transactions. The activity journal lists the following information for each transaction:

- *Assigned number*, starting each day at 001
- *Remote location* called
- *Resolution mode*
- *Starting date and time*
- *Duration*, in minutes and seconds
- *Length*, in number of pages
- *Department code* (see pages 2.62–2.63)
- *Result of the call* — If preceded by an asterisk (*), this signifies an ECM communication (see page 2.4)
- *Any special operations* — For example, a fax call made using an optional handset will appear as “Manual”

Your fax machine will print the activity journal automatically after 100 transactions. To toggle this automatic printing on or off:

- 1 Press ►/PROGRAM, G, 1, ENTER. The LCD shows:

```
Auto Print      :Off
Program/Enter
```

- 2 Press ◀ or ►/PROGRAM until the mode you want appears. Here, we've chosen *On*.

```
Auto Print      :On
Program/Enter
```

- 3 Press ENTER to save the setting.

Printing an activity journal manually

To print an activity journal *immediately* without waiting for 100 transmissions to be completed, press ►/PROGRAM, G, 2, ENTER.

Setting the printing order of the activity journal

Your fax machine prints the activity journal for every fax transaction. For example, if your machine has to redial a call, it will list those redials on the journal.

If you want to list those activities in the order of their assigned numbers, you can change the printing order of the activity journal. To change the printing order:

- 1 Press ►/PROGRAM, G, 4, ENTER. The LCD shows:

```
Line Up        :Off
Program/Enter
```

- 2 Press ◀ or ►/PROGRAM until the mode you want appears.

If you want the activity journal to print in the order of assigned number, choose “On”.

Otherwise, the machine will list every fax transaction of the same command and same location.

Here, we've chosen *On*.

```
Line Up        :On
Program/Enter
```

- 3 Press ENTER to save the setting.

Setting the reports: TCRs and RCRs

Your fax machine can print *reports* of transmissions and receptions.

There are two different reports: a *transmit confirmation report (TCR)* and a *receive confirmation report (RCR)*. You can receive a TCR after sending a fax to *any* Group 3 fax machine, but the RCR function works only when you send a fax to a compatible Muratec machine. (Consult your authorized Muratec dealer with any questions about such compatibility.) Choose the type of report you want, based on the fax machines to which you're transmitting.

What the reports tell you

TCR

The TCR lists the following information for each communication:

- *Date and time* of the TCR's printout
- *Remote location* called
- *Resolution mode*
- *Starting date and time*
- *Duration*, in minutes and seconds
- *Length*, in number of pages
- *Result* of the call
- *Any special operations* — For example, a fax call made using an optional handset will appear as "Manual"
- *Sample of the document* — An image of the first page of the document

If an error occurs, the TCR tells you the remote location which was called, the *error code* and *error message* (see pages 3.9–3.11).

RCR

The RCR lists the following information for each communication:

- *Date and time*
- *Remote location* called
- *Assigned number*, starting each day at 001
- *Resolution mode*
- *Duration*, in minutes and seconds
- *Length*, in number of pages
- *Result* of the call — Either "ok" or an *error code* (see pages 3.9–3.11)

To set the printing one of these reports:

- 1** Press **▶/PROGRAM, G, 3, ENTER**. The LCD shows:

```
TCR Selected
Program/Enter
```

- 2** Press **◀** or **▶/PROGRAM** until the setting you want appears. Here, we've chosen *RCR*.

```
RCR Selected
Program/Enter
```

- 3** Press **ENTER** to save the setting. The LCD shows:

```
Auto Print      :Off
Program/Enter
```

Your machine is asking if it should print the selected report automatically after every fax you send.

- 4** Press **◀** or **▶/PROGRAM** until the setting you want appears. Here, we've chosen *On*.

```
Auto Print      :On
Program/Enter
```

- 5** Press **ENTER** to save the setting.

To turn the confirmation report feature on or off for *only* the next fax transmission, press **REPORT**.

What happens next depends on the setting you chose:

- If the light next to the **REPORT** key glows, the fax machine will print the confirmation report automatically.
- If the light next to the **REPORT** key doesn't glow, the fax machine will not print a confirmation report.

After you send this transmission, your machine returns to the setting you chose in step 2, above.

Quick Memory transmission

Using Quick Memory transmission can save you time over standard memory transmissions.

For a *normal memory transmission*, your fax: **(1)** scans your entire document into memory, **(2)** dials the other fax machine, then **(3)** transmits the document.

But with *Quick Memory transmission*, your machine doesn't wait to scan all pages into memory before dialing. After it scans the first page of your document, your machine dials the call. While dialing, connecting and transmitting, your fax machine continues to scan in the remaining pages of the document.

You can set your fax to always use Quick Memory transmission as the default.

Important: Your fax machine's memory transmission feature must be turned on to use Quick Memory transmission (see page 1.18).

To make Quick Memory transmission the default:

- 1 Press **▶/PROGRAM, J, 1, 7, ENTER**. The LCD shows:

```
Quick Tx      :On
Program/Enter
```

- 2 Press **◀** or **▶/PROGRAM** until the mode you want appears. Here, we've chosen *Off*.

```
Quick Tx      :Off
Program/Enter
```

- 3 Press **ENTER** to save the setting.

Polling

Polling allows someone to fax a document to you *without* having to make the call or pay for it. There are several kinds of polling:

- Regular polling — Your fax retrieves a document from a remote fax machine.
- F-Code polling — Your fax retrieves a document stored as a file in the remote fax machine. To do this, you must be communicating with another F-code-compatible fax machine. For more information on F-Code polling, see "F-Code communication," pages 2.46–2.47.
- Continuous polling — Your fax continuously retrieves a document from any remote fax machine at a designated time. For example, a hospital pharmacy can use this to check on orders waiting in fax machines throughout the hospital.

For polling to work, the remote machine must also be set up to *be polled*. See the remote machine's operating instructions, if necessary.

Regular polling

To set up your machine for regular polling:

- 1 Make sure the document is inserted in the *remote* fax machine.
- 2 Press **COM-OPTIONS** *twice* and then press **ENTER**. The LCD shows:

```
Enter Fax Number
—
```

- 3 Enter the remote fax machine's number by either pressing a one-touch key, entering a speed-dial number or using the numeric keypad.
- 4 To perform the regular polling *now*, skip to step 8. To perform *delayed* regular polling, go on to step 5.

- 5 Press **COM-OPTIONS, ENTER**. The LCD shows:

```
Delayed
Enter Time: 15/17:05
```

- 6 Use the numeric keypad to enter the date and time (use the *24-hour format*) when your machine should perform the delayed regular polling.
- 7 Press **ENTER**.
- 8 Press **START**.

When your machine polls for documents, it dials the number and, upon making contact with the other machine, begins receiving the document as if the other machine had placed the call.

Continuous polling

To set up your machine for continuous polling:

- 1 Press **COM-OPTIONS** six times and then press **ENTER**. The LCD shows the current time:

```
Cont Polling
Start Time : 18:30
```

- 2 Use the numeric keypad to enter the time your machine should *begin* the continuous polling. (Use the *24-hour format*.) Here, we've set it for 7:00 AM.

```
Cont Polling
Start Time : 07:00
```

Note: Press **◀** to move the cursor left, or **▶/PROGRAM** to move it right.

- 3 When the start time is set, press **ENTER** to save it. The LCD shows:

```
Cont Polling
End Time : 07:00
```

- 4 Use the numeric keypad to enter the time when your machine should *finish* the continuous polling. (Use the *24-hour format*.) Here, we've set it for 3:00 PM.

```
Cont Polling
End Time : 15:00
```

Note: If you set the end time *earlier* than the start time, the polling operation will continue until the selected end time *tomorrow*.

Note: Press **◀** to move the cursor left, or **▶/PROGRAM** to move it right.

- 5 When the end time is set, press **ENTER** to save it. The LCD shows:

```
Enter Fax Number
—
```

- 6 Enter the remote fax machine's number by either pressing a one-touch key, entering a speed-dial number or using the numeric keypad.

If you are entering only one number for continuous polling, skip to step 8. To add additional fax numbers for this operation, go on to step 7.

- 7 To add additional fax numbers, press **BROADCAST** between each one to insert a *comma* then enter the number as in step 6. You can specify up to 30 numbers (and/or call groups) for continuous polling.

```
Press Start
[03],9-5551204,S118,
```

Important: Do **not** insert a comma after the last fax number.

Note: If you enter characters by mistake, press **CANCEL** to clear them.

- 8 Press **START**.

When your machine polls for documents, it dials each number and, upon making contact with the other machine, begins receiving the document as if the other machine had placed the call. It will continue the process throughout the time period you selected in steps 2–5.

Note: When you want to end a continuous polling operation, you must delete it using the Review Commands feature (see page 2.18).

Being polled

Not only can you poll, but you can also *be* polled. To set up a document for regular polling:

- 1 If your fax machine is set for Tel Ready reception, press **AUTO ANSWER** to change it to the Auto Answer mode. The Auto Answer light will glow.

Important: Your machine **can't** be polled if it's in Tel Ready mode.

- 2 Insert the document.

- 3 Adjust resolution and contrast if necessary. (Your fax machine will be transmitting to the machine doing the polling.)

- 4 Press **▶/PROGRAM, D, 1, ENTER**. Your fax will scan the document into memory and return to standby mode.

Note: If you want to return to the "Tel Ready" mode after the remote machine has polled your document, press **AUTO ANSWER**. The Auto Answer light on the control panel will turn off. **But do this only after you're sure the remote machine has polled your document.**

Once the remote fax machine polls the document you stored, your fax machine automatically erases the document from memory.

Printing a stored polling document

To print a document you've stored for regular polling *without erasing* it, press ►/PROGRAM, D, 3, ENTER.

Erasing a stored polling document

To erase a document you've stored for regular polling from your machine's memory, press ►/PROGRAM, D, 2, ENTER.

Limiting polling access to your fax machine

Your machine's *closed network* setting (see page 2.60) works for polling, also. If a calling fax doesn't "present" the proper passcode, it cannot poll from your fax.

Note: If you're using the Block Junk Fax feature (see pages 2.60–2.61), even incoming calls which meet the passcode test must come from phone numbers you've approved.

OneLine + distinctive ring detection

Many phone companies now offer their customers a special service which makes it possible for one phone line to do the work of two.

With this service, you physically still have one phone line, but, electronically, you have two phone *numbers*. Your phone recognizes these different numbers and rings differently for each one.

For example, this makes it easy for you to have both a business number and a home number on one phone line, so you can answer one with "Jane Doe Consulting," and the other with "Hello." This works because you can tell the difference between the distinctive *patterns* of the two rings.

Your fax machine is also smart enough to tell the difference between two different numbers that are ringing it. All you have to do is set up your machine for the *OneLine + distinctive ring detection (DRD)* feature.

In order to use OneLine + DRD, your phone company must set up your distinctive ring service. When it does, it will assign a *ring pattern*. For example, the standard telephone ring is 2 seconds "on" (ringing) and 4 seconds "off" (silent), after which it repeats itself.

Your fax has eight possible distinctive ring patterns for use with OneLine + DRD. One of them should work with your phone company's DRD service. This chart lists the patterns:

Pattern	One complete ring pattern (seconds)
A	0.8 on, 0.4 off, 0.8 on, 4.0 off
B	0.4 on, 0.2 off, 0.4 on, 0.2 off, 0.8 on, 4.0 off
C	0.3 on, 0.2 off, 1.0 on, 0.2 off, 0.3 on, 4.0 off
D	1.0 on, 0.5 off, 1.0 on, 3.5 off
E	0.5 on, 0.5 off, 0.5 on, 0.5 off, 1.0 on, 3.0 off
F	0.5 on, 0.5 off, 1.0 on, 0.5 off, 0.5 on, 3.0 off
G	0.4 on, 0.6 off, 0.4 on, 4.6 off
H	1.5 on, 0.5 off, 0.5 on, 3.5 off

For example: pattern c is 0.3 seconds ringing, 0.2 seconds silent, 1 second ringing, 0.2 seconds silent, 0.3 seconds ringing and 4 seconds silent. Then it goes back to the first 0.3-second ring and starts over.

To use DRD on your fax machine:

1 Contact your phone company to make sure it has set up DRD service for you. If possible, also find out which distinctive ring pattern the phone company has assigned you.

2 Press **▶/PROGRAM, J, 2, 0, ENTER**. The LCD shows:

```
DRD                :Off
  Program/Enter
```

3 Press **◀** or **▶/PROGRAM** until the mode you want appears. Here, we've chosen *On*.

```
DRD                :On
  Program/Enter
```

4 Press **ENTER**.

```
Ring Pattern      :A
  Program/Enter
```

5 Press **◀** or **▶/PROGRAM** until the pattern you want appears. Here, we've chosen "C".

```
Ring Pattern      :C
  Program/Enter
```

6 Press **ENTER** to set your machine to the displayed ring pattern.

Important: If your telephone company gives you only very general ring pattern specifications, *or* if you encounter a problem while using your machine's DRD feature, **please try ALL of the listed ring patterns**. If you still have a problem after trying **all** of the patterns, please call the Muratec Customer Support Center. (From the United States, call 972-364-3350. For the number to call from Canada, check the documentation found inside your fax machine's box).

Important: With your machine set for using DRD, it won't respond to any ring pattern other than the one you selected above. To reset the fax so it will respond once again to normal rings, repeat steps 2–4, above — *except*, in step 3, toggle it to "Off." Your fax will now respond normally.

Call request

You can send or receive a fax message *and* have a regular phone conversation *on the same call* (although, not at the same time). This is called a *call request*. It doesn't matter whether you're sending the fax or receiving it. You may fax first and then talk, or talk first and then fax.

Important: For this feature to work, the remote fax machine must have a similar call-request capability. Your machine must also have an optional handset attached.

Note: Communicating this way disables "V.34" mode, causing the fax machine to handle the call in normal ITU-T Group 3 fashion. See page 3.20 for more information.

Faxing/receiving first, then talking

To send or receive a fax first and then talk:

- 1** While your fax machine is sending or receiving the fax, press **MONITOR/CALL**.
- 2** At the remote fax machine, the ringer will sound after that machine receives each page.
- 3** If someone answers at the remote fax machine, your fax machine will ring several times. If so, pick up the optional handset. In a few seconds, the line will open and you can begin your conversation.

Talking first, then *sending* a fax

To talk first and then send a fax:

- 1** When you've finished your phone conversation, *don't hang up*.
- 2** Insert the document you want to fax.
- 3** Adjust the resolution and contrast if necessary.
- 4** Tell the person at the other fax machine to press **START** and to hang up his/her handset. *Don't hang up **your** handset yet!*
- 5** When you hear fax tones, press **START** and hang up your fax machine's optional handset. Your fax machine will send the document.

Talking first, then *receiving* a fax

To talk first and then receive a fax:

- 1 When you've finished your phone conversation, *don't hang up*.
- 2 Tell the person at the other fax machine to press **START** and to hang up his/her handset. *Don't hang up your handset yet!*
- 3 When you hear fax tones, press **START** and hang up your machine's optional handset. Your machine will receive the document and print it out.

Responding to a call request

If someone requests a call *from* you during a fax communication, you'll hear a long ring after the receiving machine has received each page. To answer the call request:

- 1 Lift your machine's optional handset, and listen for a few seconds. You may hear a brief series of fax tones.
- 2 Shortly, the line will open and the person at the other end of the line will answer. You and the other person now can have a normal phone conversation.

Numbering pages

Just before sending a fax, you can set your fax machine to number each page. This will help the person receiving the fax to keep track of all the pages.

To set up page numbering:

- 1 Count the number of pages in your document.
- 2 Insert the document.
- 3 Adjust the resolution and contrast, if necessary.
- 4 If you want to toggle between a manual transmission or memory transmission, press **MEMORY TRANSMIT**.
- 5 Press **▶/PROGRAM, L, ENTER**. The LCD shows:

```
Enter # Of Pages
      ( 01-50 ): 01
```

- 6 Use the numeric keypad to enter the number of pages in your document. If there are fewer than 10 pages, enter a leading zero and then the number (*For example: 04 for four pages*).

- 7 Press **ENTER**.

```
Enter Fax Number
_
```

From here, continue sending the document using whatever type of transmission you need (broadcast, group dial, etc.). When the remote fax machine prints the document, a note on the right side of your TTI will indicate the number of the page — such as “P.02” for page two.

Transferring documents (Fax Forward)

This feature tells your fax machine to receive documents and then transfer them automatically to another fax machine. You can set the time period for which the fax machine will continue this process.

Note: Fax Forward will not transfer these types of received documents:

- SecureMail reception
- Polling reception
- Relay broadcast reception
- F-Code reception

Create the transfer pattern

Note: You can create up to *five* transfer patterns.

To set up transfer pattern:

- 1 Press **▶/PROGRAM, Q, ENTER**.

```
Q1 Enter Fax Forward
   Program/Enter
```

- 2 If you set up a transfer pattern at your first time, skip to step 4. If you have already set up any transfer pattern, proceed to step 3.
- 3 Press **ENTER**. The LCD shows:

```
Select Fax Forward #
1:1234
```

Press **◀** or **▶/PROGRAM** until the number you want to set up or change appears.

4 Press ENTER. The LCD shows:

```
1:Forwarding Number
_
```

5 Enter the fax number for the remote fax to which you want documents to be transferred. Use either a one-touch number, a speed-dial number, a call group or regular number dialed from the numeric keypad.

If you are entering only one number for transferring, skip to step 7.
To add any additional fax numbers for this operation, proceed to step 6.

6 To add more fax numbers, press BROADCAST between each one to insert a comma, then enter the number as described in step 3.
You can specify up to 201 numbers for transferring.

Note: You can enter only 1 location by using numeric keypad.

```
1:Forwarding Number
14567,[01],S002,G3_
```

Important: Do **not** insert a comma after the *last* fax number.

Note: If you enter characters by mistake, press CANCEL to clear them.

7 Press ENTER to save the setting. The LCD will show:

```
1:Fax Forward :On
Program/Enter
```

If you want to set to off, press ◀ or ▶/program until the mode you want appears.

8 Press ENTER. The LCD will show:

```
1:Enter Time
* **:**- * **:*
```

Start transferring End transferring
day and time day and time

9 Use the numeric keypad to enter the day and time. The machine asks time period that the machine will transfer documents.

How to enter the day and time:

- To enter the day, press following numeric keypad.

Numeric keypad 0:	Sunday
Numeric keypad 1:	Monday
Numeric keypad 2:	Tuesday
Numeric keypad 3:	Wednesday
Numeric keypad 4:	Thursday
Numeric keypad 5:	Friday
Numeric keypad 6:	Saturday

- To enter the time, using numeric keypad.
- If you do not wish to set up the day and time, enter *.

Note: To change only one digit, press ◀ to move the cursor leftward, or ▶/PROGRAM to move it rightward, to that digit. Then, enter the correct digit.

Example 1: When you set the start transferring time for 7:00 at Tuesday, and set the end transferring time for 19:00 at Friday, press **2 0 7 0 0 5 1 9 0 0**, which results in:

```
1:Enter Time
Tue 07:00--Fri 19:00
```

Example 2: When you set the start transferring time for 7:00 and set the end transferring time for 19:00 everyday, press *** 0 7 0 0 * 1 9 0 0**, which results in:

```
1:Enter Time
* 07:00-- * 19:00
```

Example 3: When you set the start day for Tuesday, and set the end day for Friday, press **2 * * * * 5 * * * ***, which results in:

```
1:Enter Time
Tue **:**-Fri **:*
```

10 Press ENTER to save the setting. The LCD will show:

```
1:Auto Print :Off
Program/Enter
```

Automatic printing determines whether the machine will print a document automatically upon receiving it:

On: A copy of every document received and transferred is printed at your machine.

Off: Received and transferred documents are not printed at your machine.

Note: If the security reception (pages 2.56–2.57) is activating, the machine does not print received document regardless of this setting.

11 Press **ENTER** to save the setting.

To setup or modify another transfer pattern, repeat steps 2-7. To finish, press **STOP**.

Printing a list of your transfer patterns

You can easily print a list of your transfer patterns. The list includes each pattern's identifier number, remote fax's number where you want documents to be transferred, On/Off setting, time period and Auto print setting.

To print the list, press **►/PROGRAM, Q, 2, ENTER**.

The power of QuadAccess®

Your fax machine's *QuadAccess* feature sharply reduces the time you might spend waiting for the machine to finish its work. QuadAccess is a more powerful version of what already is a pretty powerful feature, called *dual access*. While a fax with normal dual access allows you to do two things at once, QuadAccess allows you to do *four* operations at once. *For example*, even if the machine is (1) printing a copy, (2) transmitting from memory and (3) scanning documents for a different memory transmission, you can still (4) program the machine.

F-Code communication

F-Code: an introduction

The ITU-T, the United Nations agency that standardizes international telecommunications, has created a fax industry standard for using sub-addressing and password-based communication. One name for this standard is F-Code, and that's what we'll call it in these instructions and on your machine's display.

How sub-addressing works

To help understand sub-addressing, think about how someone in a large company receives mail. For example, mail for the Accounting department is first delivered to the company's main mailroom. Then the mailroom routes the mail to Accounting.

That's the idea behind sub-addressing. Your fax and another F-Code-compatible fax exchange special signals to indicate just where the fax really should go. It's as if the sending fax is saying, "Deliver this to room 48," and the receiving fax does just that.

Your machine has up to 50 mailboxes for these special deliveries. When someone sends an F-Code fax to you, your machine receives it into one of those 50 mailboxes — whichever box the sender chooses.

Sending F-Code securely

For greater security, you can set up a password with each F-Code sub-address, which lets you use secure transmission, polling and relay broadcasting when communicating with any other F-Code compatible fax machine.

Guidelines for using F-Code

- (1) To use ITU-T sub-addressing, you must create F-Code boxes in your machine
- (2) Your machine holds up to 50 of these boxes
- (3) Your machine stores up to 30 documents into each F-Code box (each document can include one or more pages)

Creating or modifying an F-Code box

Choosing the F-Code box type

Before you set up an F-Code box, first decide how your callers will use it — as a bulletin box, a security box or a relay box.

- **Bulletin box** — Stores documents that people in remote locations retrieve by *polling* the box. For example, your sales branches could call in at any time to get a printout of your latest prices that you've stored in a bulletin box.
A bulletin box stores both scanned and retrieved documents, and it holds its contents indefinitely (as long as the unit has AC power).
- **Security box** — Receives and stores F-Code secure communications.
- **Relay box** — Receives documents, then relays them to other machines. The machine that relays the document is called a "hub". Your fax machine can either *send* to a hub or it can *be* a hub.

4 elements of an F-Code box

Each F-Code box has the following four elements:

- (1) F-Code box number (*01-50*)
- (2) F-Code box name (up to 16 characters)
- (3) F-Code sub-address (up to 20 characters - can include numbers and the * and # characters only)
- (4) I.D. Code (4 digits)

You will choose the information for each of these elements, and enter it into your machine. The following steps will walk you through entering and changing that information.

To create or modify an F-Code box:

1 Keep pen and paper with you as you follow these steps. As you decide on a sub-address and enter it into your machine, write it down. Remember to: **(1)** write down which box goes with which sub-address, **(2)** write down any passwords or I.D. codes you enter, **(3)** keep these printed records in a safe place.

2 Press **▶/PROGRAM, P, 1, ENTER**. Depending on whether you already have a name entered for F-Code box *01*, the LCD shows:

Select F-Code Box
01:No Number Stored

or

Select F-Code Box
01:NY Branch Office

3 Use the numeric keypad to enter the two-digit number (*01-50*) of the F-Code box you want to create or modify. Here, we've entered **0, 3** and see either:

Select F-Code Box
03:No Number Stored

or

Select F-Code Box
03:Muratec America

4 If want to select a different F-Code box than the one that appears on the LCD, use the numeric keypad to enter the two-digit F-Code box number now.

5 Press **ENTER**. What you do next depends on whether you're creating or modifying the F-Code box:
If creating — skip to step 7.
If modifying — the LCD asks you to enter the proper I.D. code. The LCD shows:

03:Set F-Code Box
Enter I.D. Code:****

6 Use the numeric keypad to enter the 4-digit I.D. code (not the ITU-T sub-address and not the ITU-T password) and then press **ENTER**.

Note: If you enter an invalid I.D. code, the fax machine rejects the attempt and aborts this operation.

7 The machine is now asking you to name this F-Code box. The LCD shows:

03:Box Name;Upper
_

or

03:Box Name;Upper
Muratec America_

If you do not want to enter or change this F-Code box's name, skip to step 9.
If you do want to enter or change this F-Code box's name, go on to step 8.

8 Enter the name the same way you entered your fax name during EasyStart. An F-Code box's name can be up to 16 characters in length.

Important: As in EasyStart, enter letters and other non-numeric characters through the one-touch keys.

03:Box Name;Upper
_

The word "Upper" means the machine is currently set for entering only upper-case letters. If you press **R**, the machine will see it as an *R* (not an *r*).

To enter a lower-case letter, press **ALPHABET**. The display changes to:

03:Box Name;Lower
_

This means pressing one-touch keys will enter lower-case letters. For example, pressing **R**, will produce an *r* (not an *R*) on the display.

To switch back for upper-case entries, press **ALPHABET**.

Use the one-touch keypad to enter spaces, punctuation and symbols.

You can also use the **CODE** function to enter characters. Please review the explanation on page 2.2.

Note: To erase characters, press **CANCEL** to erase to the left.

To change just one character in the name, press **◀** to move the cursor left, or **▶/PROGRAM** to move it right. Press **CANCEL** to erase the character. Then re-enter the name correctly.

9 Press **ENTER** to save the box's name and continue. The LCD shows:

03:Sub-Address No.
_

or

03:Sub-Address No.
123456_

The fax machine now asks for this F-Code box's sub-address. This is the numerical identifier you must enter in order to communicate with any remote F-Code compatible fax.

If you do not want to change an existing sub-address, skip to step 11.

10 Use the numeric keypad to enter the sub-address to identify this F-Code box. The sub-address can be up to 20 characters in length and include any combination of numbers and the * and # characters (but no other non-numeric characters).

03:Sub-Address No.
654321_

Note: No other F-Code box in this machine can have the same sub-address as the one you enter here.

Note: To erase characters, press CANCEL to erase to the left. To change just one number, press ◀ to move the cursor left, or ▶/PROGRAM to move it right. Press CANCEL to erase the character. Then re-enter the number correctly.

11 Press ENTER to save the sub-address.

Note: If you entered a sub-address already being used by another F-Code box, the machine beeps and briefly displays:

```
03:Enter Sub-Address
Sub-Address In Use
```

The machine now returns you to step 10. Please enter a different number for your F-Code box's sub-address.

12 Next, the machine asks for your F-Code box's password. This is the password for ITU-T-compatible F-Code fax transactions. The LCD shows:

```
03:Password      or      03:Password
_                123456789*#_
```

Note: You don't need to have a password for the F-Code box. However, using a password will make your F-Code communication much more secure.

If you *do not* want to enter or change this box's password, skip to step 14.

13 Use the numeric keypad to enter this box's ITU-T-compatible password. This password can be up to 20 characters in length and include any combination of numbers and the * and # characters (but no other non-numerical characters). Here, we've entered 135*7#9.

```
03:Password
135*7#9_
```

Note: To erase characters, press CANCEL to erase to the left. To change just one character in the password, press ◀ to move the cursor left, or ▶/PROGRAM to move it right. Press CANCEL to erase the character. Then re-enter the password correctly.

Note: You cannot change the *type* of an existing F-Code box. If you're modifying an existing F-Code box and want to change the box *type*, you first must erase the old box, then create a new one.

14 Press ENTER to save the password. The LCD now shows:

```
Box Type :Bulletin
          Program/Enter
```

The fax machine is asking which box type you want to assign to this box — *bulletin*, *security* or *relay*.

Press ◀ or ▶/PROGRAM until the type of box you want appears.

15 Press ENTER.
If you chose *Bulletin*, go on to step 16.
If you chose *Security*, skip to step 17.
If you chose *Relay*, skip to step 20.

If you chose Bulletin:

16 The bulletin box has four additional settings:

- Reception protection ("Rx Protect" on the LCD)
- Automatic printing of received documents ("Auto Print")
- Overwriting documents ("Overwrite Doc.")
- Erasure of transmitted documents ("Erase Tx Doc.")

Rx Protect — *Reception protection* tells this box if it's okay to receive documents from remote locations. Callers can then poll these documents.

```
Rx Protect      :Off
                Program/Enter
```

On: *Open* this box to receive documents from callers.
Off: *Do not* open this box to receive documents from callers.

Press ◀ or ▶/PROGRAM until the mode you want appears. Then press ENTER to save the setting and go on to the next one.

Auto Print — *Automatic printing of received documents* tells the fax machine if it should print a document automatically upon receiving it into this box.

Note: This setting is available only when the reception protection (*Rx protect*) setting is set to *off* (see above).

```
Auto Print      :Off
                Program/Enter
```

On: Print the document automatically when the box receives it.
Off: Print the document manually, when you want to print it.

Press ◀ or ▶/PROGRAM until the mode you want appears. Then press ENTER to save the setting and go on to the next one.

Overwrite Doc — *Overwriting documents* tells your machine if it should overwrite (erase) existing documents when it receives a new one.

Note: This setting is available only when the reception protection setting is set to off (see *Rx Protect* on page 2.40).

```
Overwrite Doc. :Off
Program/Enter
```

On: When your machine receives a new document into this box, it will erase any documents currently stored in it.

Off: When your machine receives a new document into this box, it *will not* erase the documents stored in it. Your machine can store up to 30 documents (each document can include one or more pages) in each box.

Press ◀ or ▶/PROGRAM until the mode you want appears.
Then press ENTER to save the setting and go on to the next one.

Erase Tx Doc — *Erasure of transmitted documents* tells your machine if it should erase a document from the box after a caller retrieves (polls) the document.

```
Erase Tx Doc. :Off
Program/Enter
```

On: Your machine erases the document from the box as soon as it sends it. If you choose "On", this box can be polled only once per document.

Off: Your machine does not erase a document from the box when it's polled. As long as your machine holds AC power and you do not erase the document from the box, the document is available indefinitely for polling.

Press ◀ or ▶/PROGRAM until the mode you want appears.
Press ENTER to save the setting. Then skip to step 24.

If you chose Security:

17 The machine asks how long you want to keep a document stored in your machine's F-Code box. The LCD shows:

```
F-Code Doc Hold Time
Hold Time (00-31):00
```

18 Use the numeric keypad to enter a two-digit number indicating how many days (00-31), you want your fax machine to keep received documents in this F-Code box. Here, we've entered *09*, for nine days:

```
F-Code Doc Hold Time
Hold Time (00-31):09
```

Note: Your fax machine can store incoming documents in F-Code boxes (up to 30 documents) as long as 31 days, after which it automatically erases the documents. But if your machine has plenty of memory, you may want to override the 31-day limit in order to keep the documents indefinitely. If so, enter *00*. If you choose this, you will have to delete documents manually. (You may want to contact your authorized Muratec dealer regarding optional memory expansion.)

19 Press ENTER to save the settings. Skip to step 24.

If you chose Relay:

20 The machine asks for the fax number for the remote unit.
The LCD shows:

```
Enter Relay Number
_
```

21 Enter the fax number using a one-touch key, a speed-dial number or a call group number. You cannot use the numeric keypad to enter these numbers.

To add each fax number, press **BROADCAST** between each one to insert a *comma*, then enter the number. You can specify up to 200 numbers for a remote unit.

```
Enter Relay Number
S001,G12_
```

22 Press ENTER to save the settings. The LCD shows:

```
Select TTI :Sender
Program/Enter
```

The machine asks for the type of TTI you want to appear on the faxes that are relayed to other callers.

- **Sender** — Relay the document with sender unit's TTI (*don't* send your TTI).
- **Both** — Relay the document with both the sender unit's TTI and your TTI.
- **Yours** — Relay the document with your TTI instead of the sender unit's.

Press ◀ or ▶/PROGRAM until the mode you want appears.

23 Press **ENTER** to save the settings. The LCD shows:

```
Auto Print      :Off
Program/Enter
```

On: Print the document automatically when it's received.
 Off: The machine does not print it, but only relays it to the other machine.

Press **◀** or **▶**/**PROGRAM** until the mode you want appears.
 Then press **ENTER** to save the settings and go on to step 24.

24 The machine asks for your F-Code box's four-digit security I.D. code. This is the I.D. code for the box's security, which you use to **(1)** print a document any remote F-Code-compatible fax sends to this F-Code box or **(2)** you enter before you can make any changes to this F-Code box.

```
03:Set F-Code Box
Enter I.D. Code:0000
```

If you do not want to change the I.D. code, skip to step 27.

25 Decide on a four-digit I.D. code (0001-9999) for this F-Code box. **Write it down**, and put it in a safe place.

Important: Do not use 0000 as an I.D. code.

26 Use the numeric keypad to enter the four-digit I.D. code for this F-Code box.

Important: After completing this step, you must know this code to print documents sent to this F-Code box. Be sure to write it down.

27 Press **ENTER** to save the F-Code box information.

To create or modify another F-Code box, repeat steps 3-27.
 To finish, press **STOP**.

Printing a list of F-Code boxes

The list of F-Code boxes includes:

- (1) Each box's identifier number
- (2) Box name (if any)
- (3) Sub-address
- (4) Password
- (5) Box type
- (6) Each box's settings

To print a list of your F-Code boxes, press **▶**/**PROGRAM**, **P**, **2**, **ENTER**.

Printing a list of documents stored in your F-Code boxes

The list of documents stored in your machine's F-Code boxes includes:

- (1) Each box's identifier number
- (2) Box name (if any)
- (3) Box type
- (4) Each file number (or document number) that is stored

To print a list of documents stored in F-Code boxes, press **▶**/**PROGRAM**, **P**, **3**, **ENTER**.

Using a bulletin box

Storing a document

Your fax machine can store up to 30 *documents* in each bulletin box.

Note: For this operation to work, two things must be true:

- The bulletin box must exist on your fax machine.
- You must know the bulletin box's two-digit number (01-50) and four-digit I.D. code. (See "Creating or Modifying an F-Code box," pages 2.38-2.42, if necessary.)

To store a document in a bulletin box for polling.

1 Insert the document and make any necessary adjustments.

2 Press **▶**/**PROGRAM**, **P**, **7**, **ENTER** The LCD shows:

```
Select F-Code Box
01:No Number Stored
```

OR

```
Select F-Code Box
01:Murata Machinery
```

3 Use the numeric keypad to enter the two-digit identifier number (01-50) of the F-Code box where you want to store the document.

Here, we've entered **0, 3**:

```
Select F-Code Box
03:Muratec America
```

4 If you want to use a different F-Code box than the one that appears on the LCD, enter the box number now.

5 Press **ENTER**. The LCD shows:

```
03:Set F-Code Doc.
Enter I.D. Code:****
```

- 6** Use the numeric keypad to enter the four-digit I.D. code. Here, we've entered *2345*:

```
03:Set F-Code Doc.
Enter I.D. Code:2345
```

- 7** Press **ENTER**.
If you've entered an incorrect I.D. code, your fax machine rejects the attempt and returns to standby mode.
If you've entered the correct I.D. code, the display shows:

```
Overwrite Doc. :Off
Program/Enter
```

If you choose:

On: Your bulletin box erases the currently stored document when a new document is stored in it

Off: Your bulletin box keeps both the currently stored document and the new document, up to 30 documents in each box.

- 8** Press **◀** or **▶**/PROGRAM until the mode you want appears.
- 9** Press **ENTER** to save the setting. Your machine starts scanning the document into the selected bulletin box:

```
F-Code Doc. File: 1
A4 Mem 100%
```

Important: The file number (shown above as *1*) tells you how many documents are in this bulletin box. Your machine numbers files *1-30*. You need to know the file's number to erase or print it.

Printing a document stored in a bulletin box

You can print a document stored in your machine's F-Code bulletin boxes without erasing the document from memory.

To print a stored document:

- 1** Press **▶**/PROGRAM, **P**, **4**, **ENTER** The LCD shows:

```
Select F-Code Box
01:Murata Machinery
```

- 2** Use the numeric keypad to enter the two-digit number (*01-50*) of the F-Code bulletin box that stores the document you want to print. We've entered *03*:

```
Select F-Code Box
03:Muratec America
```

- 3** Press **ENTER**. The LCD shows:

```
03:Print F-Code Doc.
Enter I.D. Code:****
```

- 4** Use the numeric keypad to enter your F-Code box's four-digit I.D. code. Here we've entered *2345*:

```
03:Print F-Code Doc.
Enter I.D. Code:2345
```

- 5** Press **ENTER**.
If you've entered an incorrect I.D. code, your fax machine rejects the attempt and aborts this operation.
If you've entered the correct I.D. code, the display shows:

```
03:Print F-Code Doc.
File No. _
```

- 6** Use the numeric keypad to enter the file number (*1-30*) of the document you want to print. Here we've entered *3*.

```
03:Print F-Code Doc.
File No. 3_
```

Note: If you want to print *all* documents stored in the bulletin box, simply enter *0* (zero).

- 7** Press **ENTER**.
Your fax machine prints the chosen document(s), then returns to standby mode.

Note: If the F-Code box is not storing any documents, the machine briefly displays the following before returning to standby mode:

```
03:Print F-Code Doc.
No Document Stored
```

Erasing a document stored in a bulletin box

To erase a stored document:

- 1** Press **▶/PROGRAM, P, 6, ENTER** The LCD shows:

```
Select F-Code Box
01:Murata Machinery
```

- 2** Use the numeric keypad to enter the two-digit number (01-50) of the F-Code bulletin box that stores the document you want to erase. We've entered 03:

```
Select F-Code Box
03:Muratec America
```

- 3** Press **ENTER**. The LCD shows:

```
03:Erase F-Code Doc.
Enter I.D. Code:****
```

Note: If the F-Code box is not storing any documents, the machine briefly displays the following before returning to step 2:

```
Select F-Code Box
No Document Stored
```

- 4** Use the numeric keypad to enter your F-Code box's four-digit I.D. code. Here we've entered 2345:

```
03:Erase F-Code Doc.
Enter I.D. Code:2345
```

- 5** Press **ENTER**.
If you've entered an incorrect I.D. code, your fax machine rejects the attempt and aborts this operation.
If you've entered the correct I.D. code, the display shows:

```
03:Erase F-Code Doc.
File No.          _
```

- 6** Use the numeric keypad to enter the file number (1-30) of the document you want to erase. Here we've entered 3.

```
03:Erase F-Code Doc.
File No.          3_
```

Note: If you want to erase *all* documents stored in the bulletin box, enter 0 (zero).

- 7** Press **ENTER**. The LCD shows:

```
03:Erase F-Code Doc.
Check      Enter/Stop
```

Note: If you want to quit without erasing *any* document in the bulletin box, press **STOP**. The machine will return to standby mode.

Note: If the F-Code box is not storing any documents, the machine briefly displays the following and then returns to standby mode:

```
03:Erase F-Code Doc.
No Document Stored
```

- 8** Press **ENTER** to erase the document(s) and to return to standby mode.

```
Erase F-Code Doc.
**      Complete      **
```

Using a security box

Printing a document you receive

When your fax machine receives a document via ITU-T sub-addressing to an F-Code security box, your machine prints a message to let you know. The message lists: **(1)** the F-Code box number that received the document, **(2)** the Box name, **(3)** the remote machine's TTI (if any), and **(4)** the file numbers stored in the F-Code box.

You then have a certain number of days (see step 17 and 18 on page 2.41) in which to print out the document before your machine automatically erases it.

Note: For this operation to work, two things must be true:

- You must know the F-Code security box's two-digit number.
- You must know the F-Code security box's four-digit I.D. code.

To print a received message:

- 1** Press **▶/PROGRAM, P, 4, ENTER** The LCD shows:

```
Select F-Code Box
01:Murata Machinery
```

- 2** Use the numeric keypad to enter the two-digit number (*01-50*) of the F-Code security box that holds the documents you want to print. We've entered *03*:

```
Select F-Code Box
03:Muratec America
```

- 3** Press **ENTER**. The LCD shows:

```
03:Print F-Code Doc.
Enter I.D. Code:****
```

Note: If the F-Code security box is not storing any documents, the machine briefly displays the following before returning to step 2:

```
03:Print F-Code Doc.
No Document Stored
```

- 4** Use the numeric keypad to enter your F-Code box's four-digit I.D. code. Here we've entered *2345*:

```
03:Print F-Code Doc.
Enter I.D. Code:2345
```

- 5** Press **ENTER**.

- If you've entered the correct I.D. code, your fax machine prints all documents in the F-Code security box and then erases them.
- If you've entered an incorrect I.D. code, your fax machine aborts the operation and returns to standby mode.

Using a relay box

Once your fax machine receives a document via ITU-T sub-addressing to one of its F-Code relay boxes, it sends it to the other fax machines that you've set up on your relay box. (See "Creating or Modifying an F-Code box", page 2.38–2.42)

If you set the Auto print mode to *on* when you created the relay box, your machine will *print* the received document, then relay it to the other machine. Otherwise, your machine will *only relay* it to the other machines, not print it. See "If you chose Relay," pages 2.41–2.42 for more details on this setting.

Also, you can send (*relay broadcast initiation*) the document to another hub machine's F-Code box and get that machine to relay it to others. See "F-Code transmission" on page 2.46 for more detail.

The hub performs a *relay broadcast*, and the machine which sends the original document to the hub has performed a *relay broadcast initiation*.

Erasing an empty F-Code box

An F-Code box must be empty in order to erase it. (If you select an F-Code box in these steps which is not empty, the machine beeps. If this happens, print all documents in that box before erasing it.)

To erase an empty F-Code box:

- 1** Press **▶/PROGRAM, P, 5, ENTER**. The LCD shows:

```
Select F-Code Box
01:No Number Stored
```

or

```
Select F-Code Box
01:Murata Machinery
```

- 2** Use the numeric keypad to enter the two-digit identifier number (*01-50*) of the F-Code box you want to erase. Here, we've entered *0, 3* and see:

```
Select F-Code Box
03:Muratec America
```

- 3** If you want to erase a different F-Code box than the one that appears on the LCD, enter the box number now.

- 4** Press **ENTER**. If the F-Code box is empty, the LCD shows:

```
03:Erase F-Code Box
Enter I.D. Code:****
```

Important: If you select an F-Code box which is *not* empty, the machine beeps and, before returning to step 3, briefly displays:

```
Select F-Code Box
Box In Use
```

Print any documents received in the F-Code box, then repeat this procedure from the beginning to erase the box. Otherwise, select another F-Code box.

- 5** Use the numeric keypad to enter the four-digit I.D. code. Here, we've entered *2345*:

```
03:Erase F-Code Box
Enter I.D. Code:2345
```

- 6** Press **ENTER**.
 If you've entered an incorrect I.D. code, your fax machine rejects the attempt and returns to standby mode.
 If you've entered the correct I.D. code, the display shows:

```
03: Erase F-Code Box
Check Program/Enter
```

Note: If you want to quit without erasing the F-Code box you've selected, press **▶/PROGRAM**. The fax will return to step 2.

Note: If you want to quit without erasing *any* F-Code box, press **STOP**. The machine returns to standby mode.

- 7** Press **ENTER** to erase the F-Code box.

```
Erase F-Code Box
** Complete **
```

To erase another F-Code box, repeat steps 2-7.
 To finish, press **STOP**.

F-Code transmission and polling

With F-Code, your machine can send secure transmissions, perform relay broadcast initiations and even poll from other ITU-T-equipped machines, regardless of manufacturer.

You can do this two ways:

- Using the programmable one-touch key (see pages 2.52-2.54)
- Entering the ITU-T sub-address and password directly, which is what we'll describe here.

Note: For F-Code communication to work, three things must be true:

- The remote fax machine must support ITU-T sub-addressing
- The remote fax must have a mailbox with an ITU-T sub-address created on it
- You must know the ITU-T sub-address and password (if any) for the remote machine's mailbox

F-Code transmission

- 1** Insert the document.
- 2** Adjust the resolution and contrast if necessary.

- 3** If you want to toggle between manual transmission and memory transmission, press **MEMORY TRANSMIT**.

- 4** Press **COM-OPTIONS** four times and then press **ENTER**.

```
Enter Sub-Address
_
```

- 5** Use the numeric keypad to enter the appropriate sub-address in the remote machine. In this example, we've entered *123456*.

```
Enter Sub-Address
123456_
```

Note: If you make a mistake, press **CANCEL** to erase the character, then enter the correct number.

- 6** Press **ENTER**. The LCD shows:

```
Enter Password
_
```

Note: If this sub-address does not have a password, skip to step 8.

- 7** Use the numeric keypad to enter the password. In this example, we've entered *654321*.

```
Enter Password
654321_
```

- 8** Press **ENTER**. The LCD shows:

```
Enter Fax Number
_
```

- 9** Enter the fax number either by pressing a one-touch key, entering a speed-dial number or dialing from the numeric keypad. Do *not* press **START**.

- 10** What you do now depends on when you want the transmission to begin.

- To have it begin *now*, skip to step 13.
- To delay it, go on to step 11.

- 11** Press **COM-OPTIONS**, **ENTER**. The LCD shows:

```
Delayed
Enter Time: 15/17:05
```

- 12** Use the numeric keypad to enter the day and time when the transmission should begin, then press **ENTER**.

13 Press **START**.

If in step 10 you chose an immediate transmission, your fax machine begins dialing. If you chose a delayed command, the machine shows “Reserved” on the LCD, indicating that it has stored the command in memory and will complete it later.

F-Code polling

- 1** Press **COM-OPTIONS** five times and then press **ENTER**.

Enter Sub-Address
_

- 2** Use the numeric keypad to enter the appropriate sub-address. In this example, we’ve entered *123456*.

Enter Sub-Address
123456_

Note: If you make a mistake, press **CANCEL** to erase the character, then enter the correct number.

- 3** Press **ENTER**. The LCD shows:

Enter Password
_

Note: If this sub-address does not have a password, skip to step 5.

- 4** Use the numeric keypad to enter the password. In this example, we’ve entered *654321*.

Enter Password
654321_

- 5** Press **ENTER**. The LCD shows:

Enter Fax Number
_

- 6** Enter the fax number either by pressing a one-touch key, entering a speed-dial number or dialing from the numeric keypad. Do **not** press **START**.

- 7** What you do now depends upon when you want the polling to begin.
- To have it begin *now*, skip to step 10.
 - To delay it, go on to step 8.

- 8** Press **COM-OPTIONS**, **ENTER**. The LCD shows:

Delayed
Enter Time: 15/17:05

- 9** Use the numeric keypad to enter the day and time when the polling should begin, then press **ENTER**.

- 10** Press **START**.

If in step 7 you chose an immediate polling, your fax machine begins dialing. If you chose a delayed command, the machine shows “Reserved” on the LCD, indicating that it has stored the command in memory and will complete it later.

Programmable one-touch keys

Using the power of programmable one-touch keys

In order to complete some operations on your machine, you may have to follow several steps and press several different buttons. But programming your machine's *one-touch keys* (73–76) can reduce those many steps to a simple press of a key. You can “teach” the one-touch keys to carry out any of the following operations:

Communications functions:

- Delayed transmission (explained on pages 2.17–2.19)
- Broadcasting (pages 2.16)
- Regular polling (*not* continuous) (pages 2.31–2.32)
- Batch transmission (pages 2.20–2.23)
- F-Code transmission (pages 2.46–2.47)
- F-Code polling (page 2.47)

Programming a delayed transmission

To program a delayed transmission into a programmable one-touch key:

- 1 Press **►/PROGRAM, C, 1, ENTER**. The LCD shows the first empty programmable one-touch number available:

```
Select Program No.
73:No Number Stored
```

Note: If a programmable one-touch number other than 73 appears on the LCD, it means that you have already entered a number for 73.

Note: To *erase* a programmable one-touch key, see pages 2.54–2.55.

- 2 Press the key that you want to program or change. Here, we've selected 75.

```
Select Program No.
75:No Number Stored
```

Note: If you're changing a previously stored command: If your previous command for this key was a for a delayed operation, and you want to keep this key programmed for a delayed operation, use these instructions to make changes. But if you want to assign this key to a completely different operation (to Broadcast, for example), then you must first erase the stored command before programming the new one.

- 3 If you want to select a different programmable one-touch key than what appears on the LCD, press that key now.

- 4 Press **ENTER**. The LCD now shows either:

```
75:Fax#/Com-Options
_                               or                               75:Fax#/Com-Options
_                               9-5558743_
```

- 5 Use the numeric keypad to enter the number *exactly* as your machine should dial it, including whatever codes your phone system requires. The number can be up to 40 characters in length:

```
75:Fax#/Com-Options
9-5550629_
```

Your display can show only 20 characters at a time. To view characters beyond those 20, press **◀** to scroll to the left or **►/PROGRAM** to scroll to the right.

Important: Do **not** press **ENTER**.

Note: To erase characters, press **CANCEL** to erase to the left.

If you want to change just one character in the number, press **◀** to move the cursor left, or **►/PROGRAM** to move it right. Press **CANCEL** to erase it. Then re-enter the number correctly.

- 6 Now, *while you can still see the fax number on the LCD*, press **COM-OPTIONS, ENTER**. The LCD shows:

```
Delayed
Enter Time: 11/20:30
```

7 Next, tell your fax to carry out this delayed command one of these ways:

Option 1: Perform the command *once* at a certain time on a certain day of the month. (For example, “Do this at 5:05 PM on the 30th.”) To select this option, use the numeric keypad to enter the date and time when the fax should perform the command:

```
Delayed
Enter Time: 30/17:05
```

Option 2: Perform the command at a certain time *each day you press the key*. (For example, “Do this at 5:05 PM today.”) To select this option, use the numeric keypad to enter **0, 0** and then the time the fax should perform the command:

```
Delayed
Enter Time: 00/17:05
```

8 Press ENTER, ENTER.

9 The LCD now displays the next programmable one-touch key. If you *do not* want to enter or change *any other* key's programming, press STOP. Your machine returns to standby mode. If you *do* want to enter or change this key's programming, go back to step 4. If you want to enter or change *another* key's programming, go back to step 2.

Programming a broadcast / group

Programming a broadcast is very similar to programming a delayed transmission. But instead of sending to just one phone number, you set up multiple numbers for the transmission.

To program a broadcast / group into a programmable one-touch key:

1 Press ►/PROGRAM, C, 1, ENTER. The LCD shows the first empty programmable one-touch number available:

```
Select Program No.
73:No Number Stored
```

Note: If a programmable one-touch number other than **73** appears on the LCD, it means that you have already entered a number for **73**.

Note: To *erase* a programmable one-touch key, see pages 2.54–2.55.

2 Press the key you want to program or change. Here, we've selected **75**.

```
Select Program No.
75:No Number Stored
```

Note: If your previous command for this key was for a broadcast / group transmission and you want to keep this key programmed for a broadcast / group transmission, use these instructions to make changes. But if you want to assign this key to a completely different operation (for a delayed transmission, for example), then you first must erase the stored command before programming the new one.

3 If you want to select a different programmable one-touch key than the one that appears on the LCD, press that key now.

4 Press ENTER. The LCD now shows either

```
75:Fax#/Com-Options
_
```

or

```
75:Fax#/Com-Options
9-5558743_
```

5 Use the numeric keypad to enter up to 230 fax numbers — you can use any combination of call groups, one-touch keys, speed-dial numbers and manually-dialed numbers.

Important: Do not press ENTER.

Press BROADCAST to enter a comma between each number or call group.

Important: Do not insert a comma after the **last** number.

To enter a *speed-dial number*, press SPEED DIAL/TEL INDEX and the number's three-digit identifier.

To enter a *call group*, press GROUP DIAL and the group's identifier number.

```
75:Fax#/Com-Options
G5,G7,[01],S006,9-55
```

Your display can show only 20 characters at a time. To view characters beyond those 20, press ◀ to scroll to the left or ►/PROGRAM to scroll to the right.

Note: To erase characters, press CANCEL to erase to the left.

To change just one character in the number, press ◀ to move the cursor left, or ►/PROGRAM to move it right. Press CANCEL to erase it.

Then re-enter until the number correctly.

6 If you want the broadcast to begin *immediately* every time you press the key, press ENTER and skip to step 9.

If you want to *delay* the broadcast, press COM-OPTIONS, ENTER.

7 Next, tell your fax to carry out this delayed command one of these ways:

Option 1: Perform the command *once* at a certain time on a certain day of the month. (For example, “Do this at 5:05 PM on the 30th.”)
To select this option, use the numeric keypad to enter the date and time when the fax should perform the command:

```
Delayed
Enter Time: 30/17:05
```

Option 2: Perform the command at a certain time *each day you press the key*. (For example, “Do this at 5:05 PM today.”)
To select this option, use the numeric keypad to enter **0, 0** and then the time the fax should perform the command:

```
Delayed
Enter Time: 00/17:05
```

8 Press ENTER, ENTER.

9 The LCD now displays the next programmable one-touch key.
If you *do not* want to enter or change *any other* key’s programming, press STOP. Your machine returns to standby mode.
If you *do* want to enter or change this key’s programming, go back to step 4.
If you want to enter or change *another* key’s programming, go back to step 2.

Programming regular polling

Note: You cannot program *continuous* polling into a programmable one-touch key. For more information on continuous polling, see page 2.32.

To program a regular polling operation into a programmable one-touch key:

1 Press ►/PROGRAM, C, 1, ENTER. The LCD shows an empty programmable one-touch number:

```
Select Program No.
73:No Number Stored
```

Note: If a programmable one-touch number other than **73** appears on the LCD, it means that you have already entered a number for **73**.

Note: To *erase* a programmable one-touch key, see pages 2.54–2.55.

2 Press the key that you want to program or change. Here, we’ve selected **75**.

```
Select Program No.
75:No Number Stored
```

Note: If your previous command for this key was for a polling transmission and you want to keep this key programmed for a polling transmission, use these instructions to make changes. But if you want to assign this key to a completely different operation (for a delayed transmission, for example), then you first must erase the stored command before programming the new one.

3 If you want to select a different programmable one-touch key than the one that appears on the LCD, press that key now.

4 Press ENTER. The LCD now shows either:

```
75:Fax#/Com-Options
_
```

or

```
75:Fax#/Com-Options
9-5558743_
```

5 Use the numeric keypad to enter the number *exactly* as your machine should dial it, including whatever codes your phone system requires. The number can be up to 40 characters in length:

```
75:Fax#/Com-Options
9-5550696_
```

Your display shows only 20 characters at a time. To view characters beyond those 20, press ◀ to scroll to the left or ▶/PROGRAM to scroll to the right.

Important: Do **not** press ENTER.

Note: To erase characters, press CANCEL to erase to the left. To change just one character in the number, press ◀ to move the cursor left, or ▶/PROGRAM to move it right. Press CANCEL to erase it. Then re-enter the number correctly.

6 Next, *while you can still see the fax number on the LCD*, press COM-OPTIONS *twice* and then press ENTER.

7 If you want the polling to begin *immediately* every time you press the key, press ENTER and skip to step 10.
If you want to *delay* the polling, press COM-OPTIONS, ENTER.

8 Next, tell your fax to carry out this delayed command one of these ways:

Option 1: Perform the command *once* at a certain time on a certain day of the month. (For example, “Do this at 5:05 PM on the 30th.”) To select this option, use the numeric keypad to enter the date and time when the fax should perform the command:

```
Delayed
Enter Time: 30/17:05
```

Option 2: Perform the command at a certain time *each day you press the key*. (For example, “Do this at 5:05 PM today.”) To select this option, use the numeric keypad to enter **0, 0** and then the time the fax should perform the command:

```
Delayed
Enter Time: 00/17:05
```

9 Press ENTER, ENTER.

10 The LCD now displays the next programmable one-touch key. If you *do not* want to enter or change *any other* key’s programming, press STOP. Your machine returns to standby mode. If you *do* want to enter or change this key’s programming, go back to step 4. If you want to enter or change *another* key’s programming, go back to step 2.

Programming a batch transmission

For this operation to work, two things must be true:

- The batch box you’re using must exist on your fax machine.
- You must know the batch box’s identifier number (1–5).

To program a batch transmission into a programmable one-touch key:

1 Press ►/PROGRAM, C, 1, ENTER. The LCD shows the first empty programmable one-touch number available:

```
Select Program No.
73:No Number Stored
```

Note: If a programmable one-touch number other than **73** appears on the LCD, it means that you have already entered a number for **73**.

Note: To *erase* a programmable one-touch key, refer to pages 2.54–2.55

2 Press the key that you want to program or change. Here, we’ve selected **75**.

```
Select Program No.
75:No Number Stored
```

If your previous command for this key was for a different operation (for a delayed transmission, for example), you must **erase** the stored command before you go to step 4 (refer to pages 2.54–2.55).

If this key was for a batch transmission, press ENTER, then skip to step 5.

3 If you want to select a different programmable one-touch key than the one that appears on the LCD, press that key now.

4 Press ENTER, COM-OPTIONS *three times* and then press ENTER. The LCD shows:

```
Batch Tx
Enter Box No.    _
```

5 Use the numeric keypad to enter the one-digit identifier for the batch box you want to assign to this one-touch key. Here, we’ve entered **5**:

```
Batch Tx
Enter Box No.    5_
```

Note: To change an identifier already entered, press CANCEL to erase it. Then re-enter the correct identifier.

6 Press ENTER.

7 The LCD now displays the next programmable one-touch key. If you *do not* want to enter or change *any other* key’s programming, press STOP to return your machine to standby mode. If you *do* want to enter or change this key’s programming, go back to step 4. If you want to enter or change *another* key’s programming, go back to step 2.

Programming an F-Code transmission

For this operation to work, two things must be true:

- You must know how the remote fax is using each F-Code box to which you're transmitting — for example, as a security box or a relay box. Different fax manufacturers may use slightly different terms, but the concepts are the same.
- You must know the remote fax's ITU-T sub-address and password for each box to which you want to transmit.

To program an F-Code transmission into a programmable one-touch key:

- 1 Press **►/PROGRAM, C, 1, ENTER**. The LCD shows the first empty programmable one-touch number available:

```
Select Program No.
73:No Number Stored
```

Note: If a programmable one-touch number other than **73** appears on the LCD, it means that you have already entered a number for **73**.

Note: To *erase* a programmable one-touch key, see pages 2.54–2.55.

- 2 Press the key you want to program or change. Here, we've selected **75**.

```
Select Program No.
75:No Number Stored
```

Note: If your previous command for this key was for an F-Code transmission and you want to keep this key programmed for an F-Code transmission, use these instructions to make changes. But if you want to assign this key to a completely different operation (for a delayed transmission, for example), then you first must erase the stored command before programming the new one.

- 3 If you want to select a different programmable one-touch key than the one that appears on the LCD, press that key now.

- 4 Press **ENTER**. The LCD now shows either:

```
75:Fax#/Com-Options
_
```

or

```
75:Fax#/Com-Options
9-5558743_
```

- 5 Use the numeric keypad to enter the number *exactly* as your machine should dial it, including whatever codes your phone system requires. The number can be up to 40 characters in length:

```
75:Fax#/Com-Options
9-5558422_
```

Your display shows only 20 characters at a time. To view characters beyond those 20, press **◀** to scroll to the left or **►/PROGRAM** to scroll to the right.

Important: Do **not** press **ENTER**.

Note: To erase characters, press **CANCEL** to erase to the left. To change just one number, press **◀** to move the cursor left, or **►/PROGRAM** to move it right. Press **CANCEL** to erase it. Then re-enter the number correctly.

- 6 Now, *while you still can see the fax number on the LCD*, press **COM-OPTIONS** three times and then press **ENTER**. The LCD shows:

```
Enter Sub-Address
_
```

- 7 Use the numeric keypad to enter the ITU-T sub-address for the box to which you want to send the document. Here, we've entered *123456*:

```
Enter Sub-Address
123456_
```

- 8 Press **ENTER**. The LCD shows:

```
Enter Password
_
```

Note: If there isn't a password for this box, press **ENTER**, then skip to step 12.

- 9 Use the numeric keypad to enter the appropriate ITU-T password for the box. Here, we've entered *654321*:

```
Enter Password
654321_
```

When finished, press **ENTER**.

- 10 If you want the transmission to begin *immediately* every time you press the key, press **ENTER** and skip to step 13. If you want to *delay* the transmission, press **COM-OPTIONS, ENTER**.

11 Next, tell your fax to carry out this delayed command one of these ways:

Option 1: Perform the command *once* at a certain time on a certain day of the month. (For example, “Do this at 5:05 PM on the 30th.”) To select this option, use the numeric keypad to enter the date and time when the fax should perform the command:

```
Delayed
Enter Time: 30/17:05
```

Option 2: Perform the command at a certain time *each day you press the key*. (For example, “Do this at 5:05 PM today.”) To select this option, use the numeric keypad to enter **0, 0** and then the time when the fax should perform the command:

```
Delayed
Enter Time: 00/17:05
```

12 Press ENTER, ENTER.

13 The LCD now displays the next programmable one-touch key. If you *do not* want to enter or change *any other* key’s programming, press STOP to return your machine to standby mode. If you *do* want to enter or change this key’s programming, go back to step 4. If you want to enter or change *another* key’s programming, go back to step 2.

Programming F-Code polling

For this operation to work, three things must be true:

- The document which you’re polling must exist in the remote fax’s F-Code box (ITU-T standard sub-addressing/password box).
- You must know the remote fax’s ITU-T sub-address and password (if any) for each box you want to poll.

To program an F-Code polling operating into a programmable one-touch key:

1 Press ►/PROGRAM, C, 1, ENTER. The LCD shows the first empty programmable one-touch number available:

```
Select Program No.
73:No Number Stored
```

Note: If a programmable one-touch number other than **73** appears on the LCD, it means that you have already entered a number for **73**.

Note: To *erase* a programmable one-touch key, refer to pages 2.54–2.55.

2 Press the key you want to program or change. Here, we’ve selected **75**.

```
Select Program No.
75:No Number Stored
```

Note: If your previous command for this key was for an F-Code polling operation and you want to keep this key programmed for an F-Code polling operation, use these instructions to make changes. But if you want to assign this key to a completely different operation (for a delayed transmission, for example), then you first must erase the stored command before programming the new one.

3 To select a different programmable one-touch key than the one that appears on the LCD, press that key now.

4 Press ENTER. The LCD now shows either:

```
75:Fax#/Com-Options
_
```

or

```
75:Fax#/Com-Options
9-5558743_
```

5 Use the numeric keypad to enter the number *exactly* as your machine should dial it, including whatever codes your phone system requires. The number can be up to 40 characters in length:

```
75:Fax#/Com-Options
9-5558422_
```

Your display shows only 20 characters at a time. To view characters beyond those 20, press ◀ to scroll to the left or ►/PROGRAM to scroll to the right.

Important: Do **not** press ENTER.

Note: To erase characters, press CANCEL to erase to the left. To change just one character in the number, press ◀ to move the cursor left, or ►/PROGRAM to move it right. Press CANCEL to erase it. Then re-enter the number correctly.

6 Now, *while you can still see the fax number on the LCD*, press COM-OPTIONS *four times* and then press ENTER. The LCD shows:

```
Enter Sub-Address
_
```

7 Use the numeric keypad to enter the ITU-T sub-address for the box you want to poll. Here, we’ve entered *123456*:

```
Enter Sub-Address
123456_
```

8 Press **ENTER**. The LCD shows:

```
Enter Password
_
```

Note: If this box doesn't have a password, press **ENTER**. Then skip to step 12.

9 Use the numeric keypad to enter the ITU-T password for the box. Here, we've entered *654321*:

```
Enter Password
654321_
```

When finished, press **ENTER**.

10 If you want the transmission to begin *immediately* every time you press the key, press **ENTER** and skip to step 13.

If you want to *delay* the transmission (perhaps to take advantage of lower phone rates), press **COM-OPTIONS**, **ENTER**.

11 Next, tell your fax to carry out this delayed command one of these ways:

Option 1: Perform the command *once* at a certain time on a certain day of the month. (For example, "Do this at 5:05 PM on the 30th.") To select this option, use the numeric keypad to enter the date and time when the fax should perform the command:

```
Delayed
Enter Time: 30/17:05
```

Option 2: Perform the command at a certain time *each day you press the key*. (For example, "Do this at 5:05 PM today.") To select this option, use the numeric keypad to enter **0, 0** and then the time when the fax could perform the command:

```
Delayed
Enter Time: 00/17:05
```

12 Press **ENTER**, **ENTER**.

13 The LCD now displays the next programmable one-touch key. If you *do not* want to enter or change *any other* key's programming, press **STOP** to return your machine to its usual standby mode. If you *do* want to enter or change this key's programming, go back to step 4. If you want to enter or change *another* key's programming, go back to step 2.

Fax dialing with programmable one-touch

To dial a fax call using a programmable one-touch number:

- 1** Insert the document.
- 2** Make any necessary adjustments as usual.
- 3** Press the programmable one-touch key in which you've stored the fax communication command.

Your fax will perform the operation now, or at whatever time you programmed.

Note: To review the details of each operation, review the instructions for that operation. See page 2.48 for a list of each operation and where to find it.

If you programmed this key to delay its operation, the LCD shows:

```
** Reserved **
Jan 29 2000 17:17
```

If you programmed this key to perform the operation immediately after you press it, the LCD shows the number:

```
9-1-972-555-4335
A4 Normal
```

Erasing a programmable one-touch key

- 1** Press **▶/PROGRAM**, **C**, **2**, **ENTER**. The LCD shows the first programmable one-touch number that has been programmed:

```
Select Program No.
73:Delayed
```

Note: If a one-touch number other than **73** appears, it means **73** is empty.

- 2** Press the programmable one-touch key you want to erase. Here, we've selected **75**:

```
Select Program No.
75:Polling
```

- 3** To erase a different programmable one-touch key than the one that appears on the LCD, press that key now.

4 Press **ENTER**. The LCD shows:

```
Erase P One-Touch
Check Program/Enter
```

Important: If you want to quit without erasing the programmable one-touch key you've selected, press **►/PROGRAM**. The fax will return to step 2.

5 Press **ENTER** to erase the number.

```
Erase P One-Touch
** Complete **
```

To erase another programmable one-touch key, repeat steps 2–5. Or press **STOP** to return to standby mode.

Printing a list of your programmable one-touch keys

You fax machine can print a list of the commands you've stored in your programmable one-touch keys.

The list includes:

- (1) each key's one-touch number
- (2) the fax/telephone number
- (3) when the command should start
- (4) which command you've selected
- (5) if applicable, the selected call group(s) or F-Code box(es) you've stored in the key
- (6) the individual settings for each key

To print a list of programmable one-touch keys, press **►/PROGRAM, C, 3, ENTER**.

Security features

Your machine has a number of security features to keep your private fax documents private, avoid unwanted outside communication and even protect against unauthorized use of your machine.

These security features include: (1) security reception, (2) PIN mask, (3) security transmission, (4) closed network, (5) block junk fax, and (6) department codes.

The passcode

Your machine has a *passcode protection* system which must be turned on in order to use the security features listed above.

To set your machine's passcode:

- 1 Decide on the four-digit passcode (0001-9999) you want to use. Write it down, and put it in a safe place.

Important: Do *not* use 0000. This turns off passcode protection.

- 2 Press ►/PROGRAM, J, 1, 6, ENTER. The LCD shows:

```
Protect Passcode
Old Passcode   :****
```

- 3 If you are *creating* a passcode, use the numeric keypad to enter 0000. If you are *changing* an *existing* passcode, enter the existing passcode.

- 4 Press ENTER.

- 5 Enter the new four-digit passcode. Here, we've entered 6296:

```
Protect Passcode
New Passcode   :6296
```

- 6 Press ENTER to save the passcode.

Note: Any time you want to turn off the passcode, change the passcode back to 0000 by repeating steps 2-6 and entering 0000 in step 5.

Security reception

Security reception tells your machine to keep *all* received faxes in memory (but not print them). Then you can print them out later, at your convenience. For example, you could use this if you're concerned about workers reading documents intended for your eyes only.

Important: For this feature to work, you must have activated the *passcode protection* as described on left column. You must also *know* the passcode.

Note: In the following instructions, your machine's LCD shortens the word *Transmission* to *Tx* and the word *Receive* to *Rx*.

Activating security reception

- 1 Press ►/PROGRAM, 0 [the letter *O*, not a zero], 1, ENTER. The LCD shows:

```
Set Security Rx
Enter Passcode :****
```

- 2 Use the numeric keypad to enter the protection passcode. Here, we've entered 6296:

```
Set Security Rx
Enter Passcode :6296
```

- 3 Press ENTER. The LCD shows:

```
Security Rx   :Off
Program/Enter
```

- 4 Press ◀ or ►/PROGRAM until the setting you want appears. Here, we've chosen "On."

```
Security Rx   :On
Program/Enter
```

- 5 Press ENTER. The LCD shows the machine's current clock setting:

```
Set Security Rx
Enter Time:   15:42
```

6 If you want security reception to begin *now* (and at this same time every day), skip to step 9. Otherwise, go on to step 7.

7 Use the numeric keypad to enter the time (use a 24-hour format) when security reception should begin every day. “Type over” the numbers displayed. Here, we’ve entered 17:35:

```
Set Security Rx
Enter Time:   17:35
```

To change a digit, press ◀ to move to the left, or ▶/PROGRAM to move right. Then enter the correct digit.

9 Press ENTER to save the setting.

Printing from security reception / Turning off security reception

When security reception is on, an incoming fax goes directly into your machine’s memory and the MEMORY RECEIVE light comes on. But the fax is not printed.

To retrieve the faxes received during this security reception (and to return your machine to normal reception until the next time):

1 Press ▶/PROGRAM, 0 [the letter *O*, not a zero], 2, ENTER. The LCD shows:

```
Print Mem Rx Doc.
Enter Passcode: ****
```

2 Use the numeric keypad to enter the passcode. Here, we’ve entered 6296:

```
Print Mem Rx Doc.
Enter Passcode: 6296
```

3 Press ENTER.

- If you’ve entered the correct passcode, your fax machine will print all documents in its memory and then erase them. Then it will turn security reception off until the next time you’ve scheduled security reception.
- If you’ve entered an incorrect code, your fax machine will refuse to print, and security reception remains on.

Masking the PIN

To prevent unauthorized long-distance calls, some office telephone systems require you to enter a *personal identification number (PIN)* whenever you dial long distance.

Your fax’s *PIN mask feature* helps you keep that PIN number private. With the PIN mask activated, you can dial a fax number plus a PIN, but the PIN will not appear in a journal, error message printout, delayed command list or a TCR. The PIN may be up to eight characters in length. It also can include the * or # symbols, and it can be entered from the numeric keypad.

There are three possible settings for the PIN mask:

- *Off* — Turns off the PIN mask feature. Any PIN you enter will appear on any display or printout which shows the number you dial.
- *Mode 1* — Each *remote fax unit* has a departmental PIN access code.
- *Mode 2* — Each *fax user* has a departmental PIN access code.

Note: If you select Mode 1 and you will use a one-touch or speed-dial number, you must store the remote unit’s PIN access code within that number. However, if you select Mode 2, this isn’t necessary. (See “Autodialing while using the PIN mask,” next page for further details.)

Note: If you select either Mode 1 or Mode 2 and will be using batch transmission (see pages 2.20 – 2.23), you must store the PIN access code for the remote unit within the appropriate batch box.

Activating the PIN mask

Important: For this feature to work, you must have activated the *passcode protection* as described on page 2.56. You must also *know* the passcode.

1 Press ▶/PROGRAM, J, 1, 5, ENTER. The LCD shows:

```
Set PIN Mode
Enter Passcode :****
```

2 Use the numeric keypad to enter the four-digit passcode. Here, we’ve entered 6296.

```
Set PIN Mode
Enter Passcode :6296
```

Note: If you enter an invalid passcode, the machine’s security feature rejects the attempt and returns to standby mode.

3 Press ENTER.

```
PIN Mode      :Off
Program/Enter
```

- Press ◀ or ▶/PROGRAM until the mode you want appears. In this example, we've chosen "Mode1."

```
PIN Mode      :Model
Program/Enter
```

- Press ENTER.

Autodialing while using the PIN mask

Note: The following instructions presume you understand how to set and use your machine's autodialer. If you need to review, see pages 2.7–2.15.

If you chose "Mode 1" — the PIN goes in

In Mode 1, before autodialing a number for the first time, you must add the PIN to the stored one-touch key or speed-dial number. Here's how:

- Begin by creating or changing an entry in the autodialer. See pages 2.7–2.15 if necessary. While you're setting this up, the machine asks you to enter the PIN. The LCD shows:

```
Set PIN Number
Enter Passcode :****
```

- Use the numeric keypad to enter the four-digit passcode. Here, we'll use our sample passcode again.

```
Set PIN Number
Enter Passcode :6296
```

- Press ENTER. In our example, we're setting speed-dial number 001:

```
001:PIN Number
_
```

- Use the numeric keypad to enter the desired PIN, up to eight characters in length.

```
001:PIN Number
1057_
```

- Press ENTER to save the PIN.

Note: If you press ENTER without entering the PIN, the fax machine beeps, indicates "Invalid Number" on the LCD and then returns to step 4.

Now you may autodial the number as usual.

Important: While in PIN Mode 1, *any* autodialer numbers you use must include the PIN. This also applies to autodialer numbers used with batch transmission (see pages 2.20–2.23) or programmable one-touch keys (see pages 2.48–2.55).

Note: If you select either Mode 1 or Mode 2 and will be using batch transmission, you must store the PIN access code for the remote unit within the appropriate batch box.

If you chose "Mode 2" — as you autodial, load the code

In this mode, you *don't* have to add the PIN to the autodialer setting. Instead, you enter the PIN manually each time you autodial:

- Dial the number as you normally would, using the autodialer. Here, we've pushed one-touch key A. The machine now asks for the PIN:

```
Enter PIN Number
_
```

- Use the numeric keypad to enter the PIN.

```
Enter PIN Number
1057_
```

- Press START. Your machine dials the number.

Note: If you select either Mode 1 or Mode 2 and will be using batch transmission (see pages 2.20–2.23), you must store the PIN access code for the remote unit within the appropriate batch box.

Dialing from the numeric keypad while using the PIN mask

If you've specified Mode 1 — use "star" power

- Enter the phone number, then press the * ("star") key and enter the PIN. *The PIN always goes last.* For example, to dial 19725550911 with a PIN of "123456", enter 19725550911*123456:

```
Press Start
19725550911*123456
```

- Press START. The PIN disappears from the display, and your machine dials the desired phone number.

If you've specified Mode 2 — the machine guides you

- 1 Enter the phone number as usual.

```
Press Start
19725550911_
```

- 2 Press **START**. The LCD shows:

```
Enter PIN Number
_
```

- 3 Use the numeric keypad to enter the PIN.

```
Enter PIN Number
123456_
```

- 4 Press **START**. Your machine dials the number.

Performing batch transmission while using the PIN mask

Note: The following instructions presume you are familiar with how to set and use both your machine's autodialer and its batch transmission feature. If you need to review, see pages 2.7–2.15 for more on the autodialer and/or pages 2.20–2.23 for more on batch transmission.

If you've specified Mode 1 or Mode 2

Important: Any autodialer number you use with batch transmission *must* include the PIN. (To review how to include this information in an autodialer number, review the Mode 1 instructions under "Autodialing while using the PIN mask," page 2.58.)

Before sending a batch transmission the first time, you must store the PIN within its batch box. Here's how:

- 1 Follow the steps for creating or modifying a batch box (pages 2.20–2.21). The LCD asks for the fax number (here, we're working with batch box 1):

```
1:Fax Number
_
```

- 2 Enter an autodialer number, or use the numeric keypad to enter the fax number, to which the batch transmission should go.

Important: If you're entering a number from the numeric keypad, enter the fax number, followed by the * ("star") key and then the PIN.

- 3 Press **ENTER** to save the setting.

Note: If you press **ENTER** without entering the PIN, the fax machine beeps, indicates "No PIN Number" on the LCD and then returns you to step 2.

- 4 Continue with the steps for creating or modifying a batch box (pages 2.20–2.21).

Now you can perform batch transmission to this box while the PIN mask is activated.

Setting security transmission

Your fax's *security transmission* feature provides extra assurance that your documents go where you're sending them. When this feature is activated and your machine sends a fax, the machine compares the last four digits of the dialed number to the other unit's Subscriber ID (the phone number at the top of that unit's transmissions; see page 1.16). If these digits match, your call goes through. If they don't, your machine disconnects the call and prints an error message telling you to check the condition of the remote unit.

Before you activate this feature, consider:

- *Not all fax machine owners enter their phone numbers in their Subscriber IDs.* — Indeed, some machines don't even *have* a Subscriber ID. So, with security transmission activated, your machine would disconnect its calls to such machines.
- *Access codes can cause confusion.* — If an autodialer entry ends with a long-distance or other access codes, activating this feature prevents calls to that fax.

Note: In the following instructions, your fax's LCD abbreviates *Transmission* as *Tx*.

- 1 Press **▶/PROGRAM, J, 1, 0, ENTER**. The LCD shows the current setting:

```
Security Tx      :Off
Program/Enter
```

- 2 Press **◀** or **▶/PROGRAM** until the mode you want appears. In this example, we've chosen *On*.

```
Security Tx      :On
Program/Enter
```

- 3 Press **ENTER** to save the setting.

Setting for use with a closed network

For maximum communications security, use a *closed network*. This limits your machine to only communicating with other Muratec fax machines which can “present” the proper passcode.

Important: The passcode you use for closed network operation is **not** the same as the protection passcode.

Once your machine is set up for a closed network, your machine will disconnect calls coming in from fax machines other than Muratec fax machines.

To set your fax machine's closed network password:

1 Decide on the four-digit closed network passcode (0001–9999) you want to use. **Write it down**, and *put it in a safe place*.

2 Press **▶/PROGRAM, J, 0, 8, ENTER**. The LCD shows the current code:

```
Set Passcode
Passcode      : 0000
```

3 Use the numeric keypad to enter the desired four-digit *closed network passcode*.

```
Set Passcode
Passcode      : 5627
```

4 Press **ENTER** to save the setting.

Note: To turn off the closed network passcode and return to normal fax reception, change the code to 0000 by repeating steps 1–4 and entering 0000 in step 3.

To set your fax machine to operate in a closed network:

1 Press **▶/PROGRAM, J, 0, 9, ENTER**. The LCD shows your fax's current setting:

```
Closed Net.   : Off
Program/Enter
```

2 Press **◀** or **▶/PROGRAM** until the mode you want appears. Here, we've chosen *On*.

```
Closed Net.   : On
Program/Enter
```

3 Press **ENTER** to save the setting.

Setting Block Junk Fax

Your fax machine's *Block Junk Fax* feature lets you bar the gates against unauthorized incoming faxes (“junk fax”). But before you block junk fax, first understand *how* this feature works, to determine if it's right for you. There are four possible settings for Block Junk Fax:

- *Off*— The feature isn't activated.
- *Mode1*— Your fax machine checks whether the last four digits of any phone number in your autodialer matches the last four digits of the remote fax's subscriber ID (the phone number part of the TTI). If it doesn't find a match, your machine disconnects the call.
- *Mode2*— This mode rejects any call from a number whose last eight digits match any number in the *blocked numbers list* (explained later). Your machine can hold up to 30 blocked numbers.
- *Mode3*— This rejects numbers that are *not* in the autodialer and also rejects numbers that *are* in the blocked numbers list. This lets you keep a number on your autodialer for transmission to it, while still blocking its incoming calls by putting it in the blocked numbers list.

But before you activate the Block Junk Fax feature, please consider:

- *Not all fax machine owners enter their phone numbers in their Subscriber IDs.*— With Block Junk Fax activated, your machine would reject faxes from these machines.
- *Access codes can cause confusion.*— If an autodialer entry ends with extra codes, such as long-distance codes, Block Junk Fax will block out calls from those faxes.

To set Block Junk Fax:

1 Press **▶/PROGRAM, J, 1, 1, ENTER**. The LCD shows your fax's current setting:

```
Block Junk Fax: Off
Program/Enter
```

2 Press **◀** or **▶/PROGRAM** until the mode you want appears. Here, we've chosen *Mode2*.

```
Block Junk Fax: Mode2
Program/Enter
```

3 Press **ENTER** to save the setting. What you do next depends on what you selected in step 1:

- If you selected *Off* or *Mode1*, your machine returns to standby mode.
- If you selected either *Mode2* or *Mode3*, go on to step 4.

- 4** The LCD now asks if you want to enter a number:

```
Set BlockJunk Dial
Program/Enter
```

If you want to enter or modify a number, press **ENTER** and go on to step 5. Otherwise, press **►/PROGRAM** and skip to step 10.

- 5** Depending on if you have already entered at least one number into the blocked numbers list, the display shows one of the following:

```
Enter Fax Number
01: _
```

or

```
Select BlockJunk No.
01:555-2971
```

- 6** If you want to modify an existing entry in the blocked numbers list, press **◀** or **►/PROGRAM** until you see the number you want to modify.

... or ...

If you want to enter a new number in an already-started blocked numbers list, press **◀** or **►/PROGRAM** until you find an empty position in the list.

Then press **ENTER** to enter or modify the blocked number.

Note: To *clear* a number from the list, see “Clearing a number from the blocked numbers list,” right column.

- 7** Use the numeric keypad to enter *the last eight characters* of a fax number you want to block. For example, if you want to block a fax from someone with a Subscriber ID of 972-555-3038, you should enter **5, 5, 5, DIALING OPTIONS, 3, 0, 3, 8**:

```
Enter Fax Number
01:555-3038
```

To change a specific digit, press **◀** to move left or **►/PROGRAM** to move right until the cursor is under the digit, then use the numeric keypad to enter the correct number.

- 8** Press **ENTER** to save the setting. The display shows the next “slot” in the blocked numbers list.
If you *do not* want to enter or change a number for this slot, go on to step 9.
If you *do* want to enter or change a number for this slot, repeat steps 5–8.

- 9** Press **STOP**. The display now asks if you want to print the list.

```
Print BlockJunk Dial
Enter/Stop
```

- 10** If you *do* want to print the list, press **ENTER** and your machine will print it. If you *don't* want to print it, press **STOP** and your machine will return to standby mode.

Clearing a number from the blocked numbers list

To *clear* a number from the list:

- 1** Press **►/PROGRAM, J, 1, 1, ENTER**.
If your Block Junk Fax setting is either *Mode2* or *Mode3*, skip to step 3.

```
Block Junk Fax:Off
Program/Enter
```

- 2** Press **◀** or **►/PROGRAM** until you see your preference, *Mode2* or *Mode3*.

```
Block Junk Fax:Mode2
Program/Enter
```

- 3** Press **ENTER, ENTER**. The display shows:

```
Select BlockJunk No.
01:555-2971
```

- 4** Press **◀** or **►/PROGRAM** until you see the number you want to clear.

- 5** Press **CANCEL** to clear the number.
To clear another number from the blocked numbers list, repeat steps 4–5. Otherwise, go on to step 6.

- 6** Press **STOP**. The display now asks if you want to print the blocked numbers list.

```
Print BlockJunk Dial
Enter/Stop
```

If you *do* want to print the list, press **ENTER** and your machine will print it. Otherwise, press **STOP** to return your machine to standby mode.

Using department codes

You can keep track of how your machine is used through its *department code* feature. When the department code setting is activated, the machine reminds each user to enter the department code before sending or polling a document. The Activity Journal then keeps track of fax transactions by department.

After you turn on this setting, assign specific code numbers to your office's fax users and tell them to enter these department codes before sending faxes.

Note: Please note that using this setting may block access to the fax machine.

Entering a department code

Your machine can hold up to 100 separate department codes.

To enter a department code:

- 1 Press **▶/PROGRAM, M, 2, ENTER**. Depending upon whether you've already entered a department code, the LCD shows:

Enter Dept. Code
001: _

or

Select Department No
001:1555

Note: If department code operation is *protected* (see page 2.63), the fax beeps briefly and then returns to standby mode. You will have to turn off the protection first, then repeat this step.

- 2 If you have not entered any codes in your fax, skip to step 4. Otherwise, go on to step 3.
- 3 To enter a new code in a department code list that's already been started, press **ENTER**. The fax will skip to the next empty position in the list.
Note: If you want to *modify* an existing entry in the department code, you first *clear* a department code you want to modify and then enter a new code (see "Clearing a department code," right column).
- 4 Use the numeric keypad to enter the four-digit department code, *0000-9999*. Here, we've entered *1555*:

Enter Dept. Code
001:1555

To change one digit, press **◀** to move left or **▶/PROGRAM** to move right until the cursor is under the digit, then use the numeric keypad to enter the correct number.

- 5 Press **ENTER** to save the setting.
To enter another department code, repeat steps 4-5.
To stop entering department codes, press **STOP** to return to standby mode.

Clearing a department code

- 1 Press **▶/PROGRAM, M, 2, ENTER**. The LCD shows:

Select Department No
001:1555

Note: If department code operation is *protected* (see next page), the fax beeps briefly and then returns to standby mode. You will have to turn off the protection first, then repeat this step.

- 2 Press **◀** or **▶/PROGRAM** until you see the code you want to clear. Here, we've selected "3111".
- 3 Press **CANCEL**.

3111:Erase Dpt. Code
Check Program/Enter

Important: If you want to quit without clearing the department code you've selected, press **▶/PROGRAM**. The fax returns to step 2.

- 4 Press **ENTER** to clear the department code.

To clear another department code, repeat steps 2-4.

If you *don't* want to clear another department code, press **STOP** to return to standby mode.

Turning the department code setting on and off

- 1 Press **▶/PROGRAM, M, 3, ENTER**. The LCD shows:

Dept. On/Off :Off
Program/Enter

Note: If department code operation is *protected* (see next page), the fax beeps briefly and then returns to standby mode. You will have to turn off the protection first, then repeat this step.

- 2 Press **◀** or **▶/PROGRAM** until you see the setting you want.

Dept. On/Off :On
Program/Enter

- 3 Press **ENTER**.

Turning department code protection on and off

Important: This feature will work only if you've activated the *passcode protection* (see page 2.56).

- 1** Press **▶/PROGRAM, M, 1, ENTER**. The LCD shows:

```
Set Dept. Protect
Enter Passcode: _****
```

- 2** Use the numeric keypad to enter the four-digit passcode:

```
Set. Dept. Protect
Enter Passcode: 6596
```

To change one digit, press **◀** to move left or **▶/PROGRAM** to move right until the cursor is under the digit, then use the numeric keypad to enter the correct number.

- 3** Press **ENTER**.

```
Dept. Protect: Off
Program/Enter
```

- 4** Press **◀** or **▶/PROGRAM** until the setting you want appears.

```
Dept. Protect: On
Program/Enter
```

- 5** Press **ENTER** to save the setting.

Sending a fax using a department code

For this operation to work, two things must be true:

- The four-digit department code must exist on your fax machine.
- You must know the department code.

- 1** Insert the document.
- 2** Adjust resolution and contrast if necessary.
- 3** Enter the fax number by either pressing a one-touch key, entering a speed-dial number or dialing from the numeric keypad.

If you enter the fax number using a one-touch key, skip to step 6. Otherwise, go on to step 4.

- 4** Press **START**.

```
Enter Dept. Code
_
```

- 5** Use the numeric keypad to enter the appropriate four-digit department code. In this example, we've entered *1234*:

```
Enter Dept. Code
1234_
```

- 6** Press **START** again.

Printing the department time list

The department time list includes the following information for each department code:

- *Time period* covered by the department time list
- Each *department code*
- *Total communication time* (in hours, minutes and seconds; *HH:MM:SS*) — Counts the communication time up to 999:59:59 (999 hours:59 minutes:59 seconds). If the fax exceeds the maximum time, it does not count further.
- *Total printed pages* — Counts the pages up to 65535 pages. If the fax exceeds the maximum number of pages, it counts the total pages from 0 (zero).

Note: If you want to clear the total counts of each department code, see "Clearing the current department time list", below.

To print the list, press **▶/PROGRAM, M, 4, ENTER**.

Note: If department code operation is *protected* (see left column), the fax beeps briefly and then returns to standby mode. You will have to turn off the protection first, then repeat the above.

Clearing the department time list

To clear the current total counts of each department code:

Press **▶/PROGRAM, M, 5, ENTER, ENTER**.

The total communication time and total printed pages for each department code are cleared. The department code will not be erased.

Just in case ...

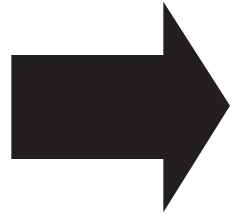

Tips on caring for your machine
What to do if problems occur
Glossary

Clearing paper jams	3.1
Print quality problems	3.4
Troubleshooting	3.6
Caring for your fax machine	3.12
Common questions	3.14
Glossary	3.17

Clearing paper jams

If an original document jams

- 1** If an original document jams, the LCD will show:

Document Jam
ContStor Enter/Cancel

If you do wish to continue the operation, press **ENTER** and proceed to step 2.

To abort the operation, press **CANCEL**. This will delete from memory all pages stored during this operation, and the machine will return to standby mode.

Important: If you wait more than 60 seconds without pressing any key, the machine will delete from memory all pages stored during this operation and the machine will return to the standby mode.

Note: If this document is a non-sorting ADF job (either copying or faxing), the machine will abort the operation anyway; instead, you'll have to perform the job again from scratch.

- 2** The LCD will show which page (i. e., which page number) is jammed. To continue scanning from the jammed page forward (keeping in mind the Note at the end of step 1, above), press **START** after clearing the jam.

p 2. Reset Document
Press Start Key

Note: If you wait more than 60 seconds without pressing any key, the machine will begin to send or copy the document(s) it has.

If you wish to cancel this operation, press **STOP**. The machine will delete all pages from memory and then return to its standby mode.

To remove the document:

- 1** Open the scanner cover by holding the scanner cover release.

Important: Hold the cover open. It won't stay open by itself.

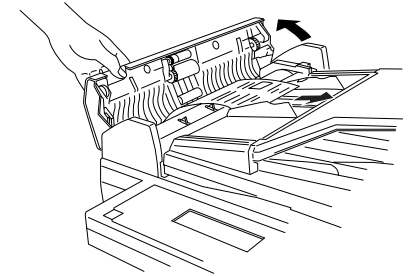

- 2** Lift the original document from the machine.

Note: If you cannot remove the original document, open the inner cover as shown at right, then remove the document.

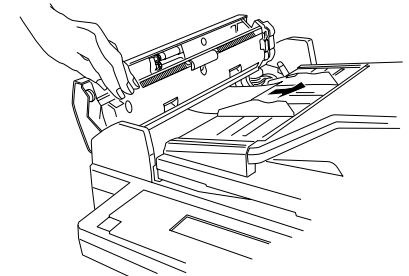

- 3** Gently close the scanner cover, making sure both sides are snapped down securely.

Note: If the original document has become wrinkled or torn, do not re-send it.

If a printout jams inside your machine

To clear a printout jammed inside your machine:

- 1 Open the top cover.

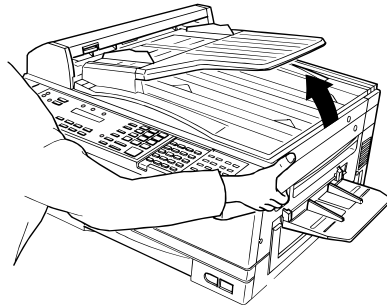

- 2 Open the printer cover.

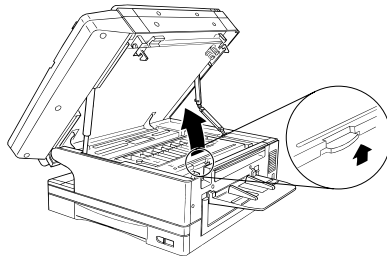

- 3 Remove the toner and drum cartridge.

Important: Shield the drum cartridge from light, especially strong light. Later, if you have to remove the cartridge from the fax, immediately wrap it in a thick cloth to protect it from light.

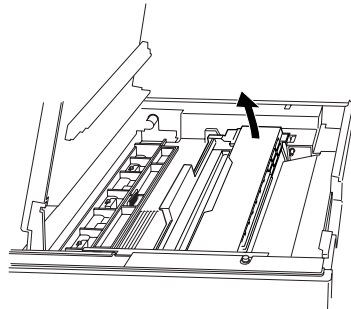

- 4 Remove the jammed paper.

Important: The fuser unit of orange color becomes very hot. **Do not touch** the fuser unit when you are removing a paper jam.

Note: Avoid getting "unfixed" toner on your hands and clothes.

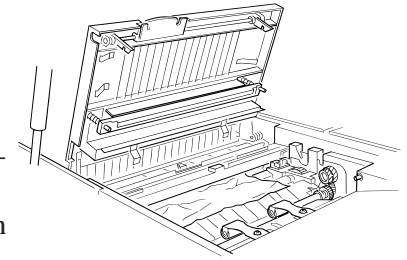

- 5 Re-set the toner and drum cartridge.

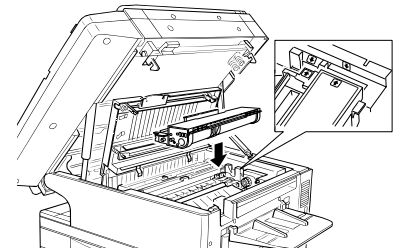

- 6 Gently close the printer cover.

- 7 Gently close the top cover, pressing firmly on the both sides of the top cover until you hear it click.

If a printout jams inside at a paper cassette's side cover

- 1** Remove the multi paper tray.

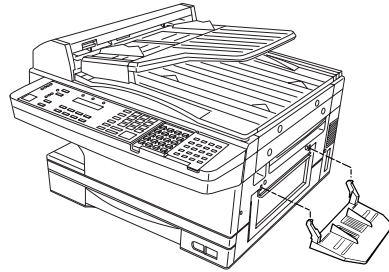

- 2** Open the side cover.
- 3** Carefully remove the jammed sheet(s) from the machine.

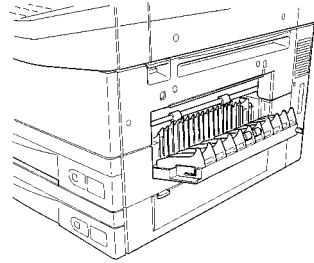

- 4** Close the side cover back into its normal position.

Print quality problems

If your machine's printouts develop quality problems, try to find the example below that matches your printout problem. When you find one which is like yours, try the suggested solutions. If they don't work, contact your authorized Muratec dealer.

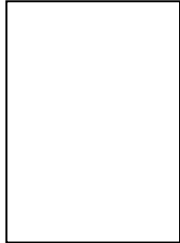

Pages are blank

- The drum cartridge or toner cartridge may not be installed correctly.
Install each cartridge correctly.
- The toner cartridge may be out of toner, or the toner may be very low.
Remove the toner cartridge and shake it a few times to redistribute the toner inside.
If the problem persists, replace the toner cartridge.
- The toner cartridge may be defective.
Remove the toner cartridge and check it for damage.
If the problem persists, replace the toner cartridge.



Pages are black

- The toner cartridge may be defective.
Remove the toner cartridge and check it for damage.
If the problem persists, replace the toner cartridge.
- Your fax machine's printer may be due for a service check.
Call your dealer.

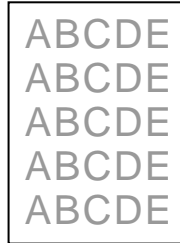

Printouts are too light

- The toner cartridge may be out of toner, or the toner may be very low.
Remove the toner cartridge and shake it a few times to redistribute the toner inside.
If the problem persists, replace the toner cartridge.
- The toner cartridge may be defective.
Remove the toner cartridge and check it for damage.
If the problem persists, replace the toner cartridge.



Printouts are too dark

- The toner cartridge may be defective.
Remove the toner cartridge and check it for damage.
If the problem persists, replace the toner cartridge.

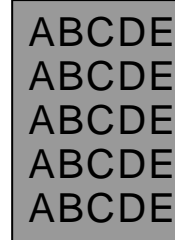

Printouts have a blurred background

- The toner cartridge may be defective.
Remove the toner cartridge and check it for damage.
If the problem persists, replace the toner cartridge.

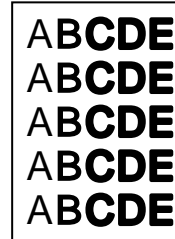

Printouts are of uneven density

- The toner may be unevenly distributed inside the toner cartridge.
Remove the toner cartridge and shake it a few times to redistribute the toner inside.
- The drum cartridge may be defective.
Remove the drum cartridge and check it for damage.
If the problem persists, replace the drum cartridge.

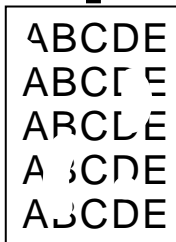

Printouts have irregularities

- The paper you're using may have absorbed moisture, perhaps due either to high humidity or water having been spilled on the paper supply. Toner will not adhere well to wet paper.
Replace the paper with dry paper and try printing again.

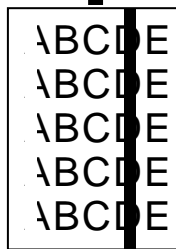

Printouts have white and/or black lines

- The toner cartridge or drum cartridge may be defective.
Remove the cartridges and check them for damage. If the problem persists, replace either or both of the cartridges as indicated.
- The LED print head may be dirty.
Using the cleaning paper, gently clean the LED print head.
- The charger may be dirty.
Your machine normally cleans the charger automatically. If other solutions fail, please contact your authorized Muratec dealer.

Printouts have black lines or multiple streaks

- The toner cartridge may have been stored improperly.
Try following procedure to clear up the problem:
 - 1** Press **COPY/FAX** to change to the copy mode.
 - 2** If there is a document in the ADF or FBS, remove it.
 - 3** Open the book-cover fully.
 - 4** Press **START** to make a black copy.

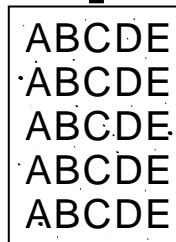

Printouts have toner smudges

- The toner may be unevenly distributed inside the toner cartridge.
Remove the toner cartridge and shake it a few times to redistribute the toner inside. If the problem persists, replace the cartridge.
- The toner cartridge or drum cartridge may be defective.
Remove the cartridges and check them for damage. If the problem persists, replace either or both of the cartridges as indicated.
- If you find smudges on the *back* of the printouts, the transport roller may be dirty.
Your machine normally cleans the transport roller automatically. If other solutions fail, please contact your authorized Muratec dealer.

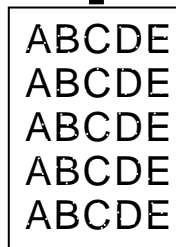

Printouts have white spots

- The charger may be dirty.
Your machine normally cleans the charger automatically. If other solutions fail, please contact your authorized Muratec dealer.

Troubleshooting

Occasionally, your fax machine encounters some trouble transmitting or receiving documents. When it does, it alerts you with an alarm. You can identify the problem with LCD messages and printed *check messages* and *error reports*, explained in the following pages.

Alarm

Your fax machine sounds an alarm tone — a series of short beeps — if either of these two problems occur:

- Trouble transmitting or receiving
- The machine is out of paper

LCD error messages

What you see on the LCD

All Commands In Use

What it means/What to do

Your fax machine has all of its 99 possible delayed commands (automatic redialing counts as one) stored in memory and cannot accept another. *Delete an existing command by using REVIEW COMMANDS, or wait until your fax has completed one of the delayed commands.*

Already Stored

You tried to enter a blocked number or department code which is already entered in the blocked numbers list for your fax machine. *Enter a different blocked number or department code.*

Box In Use

You tried to erase a F-Code box which contains at least one document. *Erase the document(s), then try again.*

Call For Service

The scanner lamp is dim or inoperable. Make repeated copies to help evaporate any internal moisture. *If that doesn't resolve the problem, call your authorized Muratec dealer or Muratec Customer Support.*

What you see on the LCD

Check Rx Paper

What it means/What to do

The paper cassette is out of paper. *Add paper to the cassette.*

Check Rx Paper Size Open&Close Top Cover

You've told your fax that the paper cassette holds legal-sized paper. If you try to use letter-sized paper without returning the pin to the upper holes (see page 1.10), your fax will sound an alarm and display the this message when you try to print. *Put the pin in the proper holes.*

Check # Of Pages

You placed fewer pages into your fax machine than you indicated in your page-numbering setting (see page 2.35). *Carefully recount the pages in your document, then re-try the transmission, being sure to enter the correct number of pages if you use the page-numbering function.*

Close Scanner Cover

The scanner cover is open. *Close it.*

Close Top Cover

The top cover is open. *Close it.*

Close 1st Cassette

The first paper cassette is open or has not been closed securely. *Close it.*

Close 2nd Cassette

The optional second paper cassette is open or has not been closed securely. *Close it.*

Close 3rd Cassette

The optional third paper cassette is open or has not been closed securely. *Close it.*

Close 1st Side Cover

The first paper cassette's side cover is open or has not been closed securely. *Close it.*

Close 2nd Side Cover

The second paper cassette's side cover is open or has not been closed securely. *Close it.*

Close 3rd Side Cover

The third paper cassette's side cover is open or has not been closed securely. *Close it.*

<i>What you see on the LCD</i>	<i>What it means/What to do</i>	<i>What you see on the LCD</i>	<i>What it means/What to do</i>
Communication Error	A communication error disrupted the reception or transmission. <i>If you were transmitting, press STOP to clear the error message and then re-try the transmission. If you were receiving a fax, try to contact the other person and have him/her re-try the transmission. (The problem may be entirely with his/her machine, phone line, etc.)</i>	Enter No. (1-99)	You tried to request greater than 99 copies from your fax, which can create 1-99 copies of a document. <i>Select the correct quantity and enter it.</i>
Copy Off	You tried to use your fax machine to make a copy, but the unit's copy protection feature (page 1.31) is on, preventing such use. <i>Turn off copy protection.</i>	Enter Scan Size	When you using the flatbed scanner (FBS), you must manually enter the scan size of your document. <i>Press BOOK DOC SIZE to choose the size.</i>
Copying Not Completed	You tried to switch to the fax mode by pressing COPY/FAX during copying from the multi paper tray. <i>Complete the copying first, then try again.</i>	Feeder In Use	The command you're trying to enter requires the use of the ADF, which is already in use. <i>Wait for the machine to stop using the ADF, then try again.</i>
Dept. Code Full	You tried to enter department code more than 100. Your machine can store up to 100 department codes.	Hang Up Phone	The optional handset is off-hook. <i>Hang it up, making sure the upper part of the handset presses down on the "hook" button.</i>
Document Full	You tried to enter an document into an F-Code box, but the machine has reached its capacity. <i>Delete documents stored in F-Code boxes until the machine will let you proceed.</i>	In Relay Box	You tried to store a document for polling in an F-Code box which is set to be a relay box. <i>Select an F-Code box which is set to be a bulletin box, then try again.</i>
Document Jam ContStor Enter/Cancl	An original document jam while you are using the ADF for either faxing or copying. <i>See page 3.1 for instructions on clearing the jam.</i>	In Secure Box	You tried to store a document for polling in an F-Code box which is set to be a security box. <i>Select an F-Code box which is set to be a bulletin box, then try again.</i>
Document Stored	You tried to erase a batch box which contains at least one document. <i>Erase the document(s), then try again.</i>	Insert Document	There was no document in the document feeder when you tried to send a fax or make a copy. <i>Place a document and try again.</i>
Drum Near End	Your drum will need to be replaced soon. <i>Press STOP to clear the message, then contact your authorized Muratec dealer to purchase a new drum cartridge if you don't already have one.</i>	Invalid I.D. Code	The F-Code box I.D. code you entered isn't valid. <i>Try re-entering your F-Code box I.D. code.</i>
Enter No. (0-32)	You tried to enter a call group number greater than 32. Your machine can maintain 32 call groups, numbered 1-32 (call group 0 covers all the groups). <i>Determine the correct call group identifier number and enter it, instead.</i>	Invalid Number	You pressed a key which has no function during the current operation.
		Invalid Passcode	The protection passcode you entered isn't valid. <i>Repeat the operation, entering the correct protection passcode.</i>
		Line Busy	You tried to erase a document which someone is polling from your machine. <i>Wait for the fax to complete the polling operation, then try again.</i>

Just in case ...

What you see on the LCD

**Memory Overflow
Enter Or Cancel**

What it means/What to do

During transmission (or copying), you tried to enter more pages into memory than your fax could store. Press **ENTER** to tell your fax to keep as many pages in memory as possible, or press **CANCEL** to delete from memory all pages stored during this operation (but not previous operations).

Mirror Carriage Error

The mirror carriage of your machine has become inoperable. Call your authorized Muratec dealer or Muratec Customer Support.

Mirror Locked

The transport mode is not turned off. Turn off the transport mode (see page 1.7, 1.12).

No Command

You pressed **REVIEW COMMANDS** to review upcoming commands, but your fax machine had none stored.

No Dept. Code

You tried to turn on the department code setting but there are no department codes stored in your fax machine. Store at least one department code, then try again.

... **or** ...

You entered incorrect department code at fax sending while the department feature is on. Enter correct department code.

No Document Stored

You tried to print a document from memory, but your fax machine had none stored.

No Drum

The drum cartridge is missing or has not been properly installed in your fax machine. Please properly install the drum cartridge.

No Number Stored

You selected an autodialer, batch box or F-Code box number for which there is no phone number programmed. Either choose another number or dial a phone number directly from the numeric keypad.

No Passcode

You tried to protect an operation or department code but there's no protection passcode stored in your fax machine. Store a protection passcode in your machine, then retry protecting the operation or department code.

What you see on the LCD

No PIN Number

What it means/What to do

You selected "Mode1" in the PIN mask feature and tried to call an autodialer number in which no PIN has been entered, or to call using numeric keypad without PIN. Enter a PIN, then try again.

No Report

You requested an activity journal or confirmation report, but your fax machine has no record of any fax jobs having occurred.

No Toner Cartridge

The toner cartridge is missing or has not been properly installed in your fax machine. Please properly install the toner cartridge.

**Open Top Cover
Please Remove Paper**

Your fax machine has detected a paper jam in its interior. See page 3.2 for instructions on clearing the jam.

**Open 1st Side Cover
Please Remove Paper**

Your fax machine has detected a paper jam inside the first cassette's side cover. Open the cassette's side cover and remove the jammed paper carefully.

**Open 2nd Side Cover
Please Remove Paper**

Your fax machine has detected a paper jam inside the second cassette's side cover. Open the cassette's side cover and remove the jammed paper carefully.

**Open 3rd Side Cover
Please Remove Paper**

Your fax machine has detects paper jam inside the third cassette's side cover. Open the cassette's side-cover and remove the jammed paper carefully.

**Open & Close ScanCover
Reset Document**

Either your document wasn't inserted correctly, or the fax to which you're sending can't handle the document's page length. Reset the page and try again.

Please Call Service

The printer unit of your fax machine has become inoperable. Call your authorized Muratec dealer or Muratec Customer Support.

Please Replace Drum

Your drum cartridge has reached the limit of its design life. Please replace the drum cartridge.

Please Replace Toner

Your toner cartridge is empty. Replace the toner cartridge.

<i>What you see on the LCD</i>	<i>What it means/What to do</i>
Please Supply Paper	The paper cassette or multiple paper feeder tray is out of paper. <i>Add paper to the cassette and/or the tray.</i>
Please Wait	Your fax machine's printer is either warming up or busy. <i>Please wait until the fax is finished printing and then re-try your command or operation.</i>
Polling In Use	You tried to store the polling document in your fax machine, where one already had been stored. <i>Wait for the fax to complete the regular polling operation, then try again.</i>
Printer In Use	The command you're trying to enter requires the use of the printer, which is already in use. <i>Wait for the fax to finish printing, then try again.</i>
Protect Doc. Stored	A received document was in your fax's memory when you tried to turn off the security reception passcode. <i>Print the received document from your fax's memory, then retry the desired operation.</i>
Remove Tray Paper Open & Close Top Cover	Your fax machine has detected a paper jam in the multi paper tray. <i>See page 3.3 for instructions on clearing the jam.</i>
Scanner In Use	The command you're trying to enter requires the use of the scanner, which is already in use. <i>Wait for the fax to complete the scan, then re-try the desired command.</i>
Stop Scanning ContStor Enter/Cancel	You opened the top cover while the machine was scanning the document (for either faxing or copying) using the FBS. <i>To continue the scan, press ENTER. To abort the scan, press CANCEL.</i>
Sub-address In Use	You tried to enter a sub-address identical to one already being used in another F-Code box. <i>Enter a different sub-address.</i>
Toner Low	Your fax machine is almost out of toner. <i>Contact your authorized Muratec dealer to purchase a new toner cartridge if you don't already have one.</i>

<i>What you see on the LCD</i>	<i>What it means/What to do</i>
Too Many Characters	You attempted to enter too many numbers or other characters in the current operation. <i>Press CANCEL to delete the extra characters, then try again. You may wish to review the operation's appropriate instructions.</i>
Too Many Locations	You tried to enter too many numbers for a broadcast. You can enter up to 10 one-touch or speed-dial numbers and numbers entered through the numeric keypad. <i>Press CANCEL to delete the extra numbers and then try again.</i>
Too Many Steps	You tried to enter too many steps for a macro. You can enter up to 60 steps into a macro key.
1 Location or Less	You tried to enter too many forwarding numbers for fax forwarding through the numeric keypad. You can enter up to 201 forwarding numbers by using one-touch key, speed dial number, group number and numeric keypad, but you can enter only 1 location by using numeric keypad (see page 2.36).

Errors

When sending faxes, your machine occasionally runs into *communications errors*. These can be caused by anything from lightning to telephone line interference. (These same factors cause the static, or *line noise*, you sometimes hear on phone calls.) They also can be caused by problems with the fax machine at the other end of the line.

Often, simply trying your call again is all that's necessary. However, *if the problem persists regularly*, call your local telephone company for help. If that doesn't help *and the problem persists regularly*, call your authorized Muratec dealer.

Error reports

When an error occurs, your fax machine prints an *error report*. Each fax error report lists an *error message* which includes:

- A possible *solution* to the problem
- The *sending location* (if the remote fax stores a Location ID of its own)
- The *result* — which is a special *error code*.
- A *sample* of the document's first page.

Kinds of error codes

The error code listed in the “Result” column of the error report indicates the specific problem encountered:

- “**D**” codes — Occur while *dialing*
- “**R**” codes — Occur during *reception*
- “**T**” codes — Occur during *transmission*

Specific errors

Following are some error codes you may see on an error report:

Dialing errors

- D.0.3, D.0.8 The remote unit didn't respond, the call couldn't be completed or **STOP** was pressed during dialing. *Re-try the call. If your machine repeats the message, call the remote fax unit's operator and verify that unit is operating properly.*
- D.0.2 The remote unit is busy. *Try the call again.*
- D.0.6, D.0.7 Either the remote unit didn't respond, the call somehow didn't go through or **STOP** was pressed during dialing. *Try the call again.*

Reception errors

- R.1.1 The calling fax machine didn't respond to your fax machine. This can happen if someone dials a wrong number or if the remote machine restricts access through use of a passcode.
- R.1.2 The two fax machines were incompatible. Your fax machine sends and receives only ITU-T Group 3 (see Glossary, page 3.18) fax communication, the industry standard since the early 1980s.
- R.1.4 Someone pressed **STOP** at the receiving fax machine.
- R.1.5 The fax machine didn't detect the silence at the end of the call for receiving an RCR.
- R.2.3 Poor phone line conditions made fax communication impossible. *Call someone at the remote machine's location.*
- R.3.1 The sending fax machine detected too many errors from the receiving fax machine.
- R.3.3 The sending fax machine is incompatible or had a document feeder problem during transmission.
- R.3.4 Poor phone line conditions may have prevented your fax machine from properly printing some or all of the pages it received.
- R.4.2 Either the line disconnected before transmission or the transmitting fax machine needs maintenance.

- R.4.4 The fax machine has reached its memory capacity.
- R.5.1, R.5.2 ECM reception failed (perhaps due to line noise).
- R.8.1 A compatibility error occurred.
- R.8.10 Line noise or other problems prevented line probing.
- R.8.11 The fax machine timed out while waiting for the retrain signal.

Transmission errors

- T.1.1 The remote fax machine didn't respond to your machine. *Call someone at the remote machine's location.*
- T.1.2 Your fax machine's page counter detected a possible document feeder error. *Carefully put the document back into the feeder and try the call again.*
- T.2.1 Either the phone line disconnected during transmission or fax communication became impossible due to bad phone line conditions. *Try the call again.*
- T.2.2 The two fax machines were incompatible. Your fax machine sends and receives only ITU-T Group 3 (see “Glossary,” page 3.18) fax communication, the industry standard since the early 1980s.
- T.2.3 Bad phone line conditions made fax communication impossible. *Conditions can change rapidly, so try the call again later.*
- T.3.1 The page counter in your fax machine detected a document feeder error during transmission. *Carefully re-insert the document into the feeder and re-try the call.*
- T.3.2 The fax machine didn't detect the silence indicating the call had ended.
- T.4.1 The telephone line disconnected during transmission because of excessive modem errors or because remote unit ran out of paper. *Try the call again.*
- T.4.2 After transmission began, poor line conditions developed. *Try the call again.*
- T.4.4 Poor line conditions prevented transmission. *Try the call again.*
- T.5.1, T.5.2, T.5.3 ECM transmission failed (perhaps due to line noise). *Conditions can change rapidly, so try the call again later.*
- T.8.1 A compatibility error occurred.
- T.8.10 Line noise or other problems prevented line probing.
- T.8.11 The remote fax machine didn't complete the equalizer training phase.

“Check Message” printouts

When there's a problem with a fax call and your machine detects an error, it produces an error printout headed by the words “Check Message.” This printout lists the following information about the transmission:

- The resulting error code
- A communications error message (see “What error messages can mean,” below)
- The phone number (or TTL, if programmed) of the fax machine with which your machine had attempted to communicate.

What error messages can mean

The error messages on Check Message printouts can mean a variety of things. Here's a brief summary:

Error message	Possible meanings
Check condition of remote fax.	<ul style="list-style-type: none"> • Remote machine malfunctioned • No “handshake” signals from remote fax • Wrong phone number reached
Repeat transmission.	<ul style="list-style-type: none"> • Poor phone line conditions • No “handshake” signals from remote fax • Document misfeed or miscount • Unable to reach remote machine after attempting specified number of redial tries
Line is busy.	<ul style="list-style-type: none"> • Remote machine's line was busy • Remote machine's line didn't answer
Check received documents.	<ul style="list-style-type: none"> • Remote confirmation signal not received from remote fax • Poor line conditions caused a poor image
Memory full.	<ul style="list-style-type: none"> • Remote fax's memory is full
Dialing number is not set.	<ul style="list-style-type: none"> • Stored phone number failed to dial properly
Stopped.	<ul style="list-style-type: none"> • Someone pressed STOP at the remote fax in the middle of the “handshake”

Caring for your fax machine

With proper installation and a little maintenance, your fax machine should give you dependable service for years to come.

Although it requires little day-to-day care, you can take these simple precautions to keep it in top form:

- **Always** make sure your fax machine is installed according to our specifications, including using an electrical surge suppressor. (If necessary, review “Pick an installation spot,” page 1.7.)
- **Always** use good, copier-quality paper.
- **Always** clean your fax machine as needed (see “Cleaning tips,” below).
- **Never** install your fax machine where it can overheat, gather dust or get splashed by any liquids (even water).

Cleaning tips

Some things to keep in mind about cleaning your fax machine:

- **Do** clean it! Dust and dirt, especially around the fax machine’s air vents can shorten your machine’s life.
- **Always** unplug the fax machine *before* you clean it.
- **Never spray any cleaner DIRECTLY onto your fax machine.** The drifting spray could damage components inside.
- **Never try to clean SEALED areas inside your fax machine.** They’re sealed to protect your safety and the machine.
- For cleaning *external* surfaces, such as the cover and handset: use a mild cleaning solution sprayed onto a lint-free towel or cloth.
- **Always** use a lint-free cloth (or swabs) moistened with alcohol to *gently* wipe components inside your machine.
- In areas you can’t reach with swabs, **always** use dry, dust-free compressed air to *gently* blow away dust and other material.

Corrective cleaning

Here are some simple cleaning procedures for keeping your fax machine operating smoothly. Use each as the need arises.

Curing frequent jams in the ADF

If you’re having trouble with getting your original documents to feed properly, try this procedure:

- 1** Turn off your fax machine.
- 2** Get two soft, lint-free cloths and moisten them as follows:
 - One with a cleaner suitable for use on platen/rubber rollers. In steps 4 and 6, we’ll call this the rollers cleaner.
 - The other with isopropyl alcohol
- 3** Open the scanner cover by holding the scanner cover release.
Important: You must hold the cover open. It won’t stay open by itself.
- 4** Use the cloth with the rollers cleaner to clean the face of the rollers. Rotate the rollers by hand to allow cleaning of the entire roller surface.

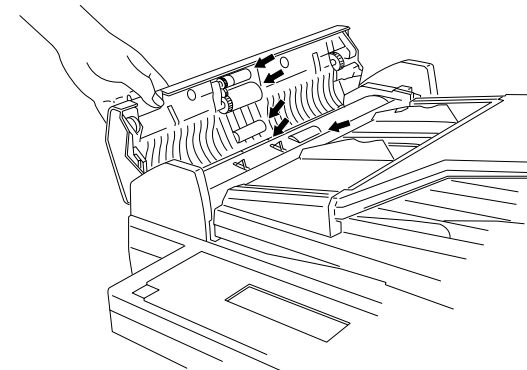

- 5** Open the inner cover.

Important: You must hold the cover open. It won't stay open by itself.

- 6** Use the cloth with the rollers cleaner to clean the face of the rollers. Rotate the rollers by hand to allow cleaning of the entire roller surface.

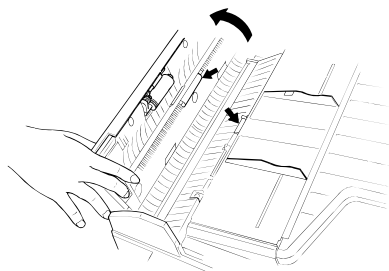

- 7** Use the cloth with isopropyl alcohol to clean the contact glass.

Important: You must hold the cover open. It won't stay open by itself.

- 8** Gently close the scanner cover, making sure both sides are snapped down securely.

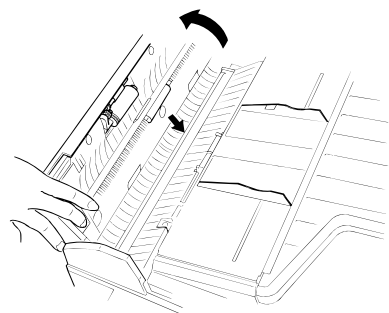

Cleaning the FBS

- 1** Open the book cover.
2 Get a soft, lint-free cloth and moisten it with isopropyl alcohol.

Important: Make sure the cloth doesn't have any rough areas. Otherwise, it could scratch the glass surface of the FBS.

- 3** Using the cloth, gently clean the glass surface of the FBS and the white background area on the underside of the book cover.

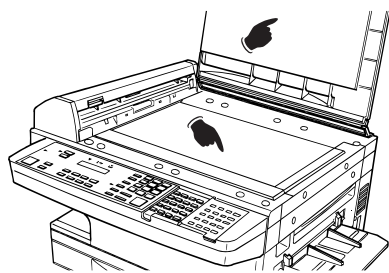

If you have unsatisfactory printout quality

Your machine automatically cleans its charger and transport roller, two items which are very important to printout quality. So, if you notice poor printout quality (whether on received faxes or on copies), it may mean that your machine requires service. Review "Print quality problems" (pages 3.4-3.5), and see whether any of the proposed solutions helps your machine. If none do, please call your authorized Muratec dealer or call the Muratec Customer Support Center at (972) 364-3350.

Cleaning the LED print head

If you find your fax recipients complaining that the faxes you receive or copy image quality are streaked, the LED print head may be dirty.

- 1** Turn off your fax machine.
2 Get a soft, lint-free cloth and moisten it with isopropyl alcohol.
3 Open the top cover and then open the printer cover.

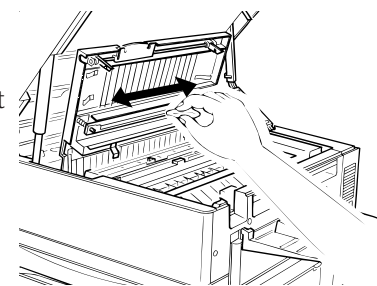

Important: The fuser unit of orange color becomes very hot.
Do not touch the fuser unit when you are cleaning the LED print head.

- 4** Using the cloth, gently clean the LED print head.
Note: **Do not** use abrasive materials on the LED print head.

Storing the toner and drum cartridge(s)

Follow these guidelines when you store the machine's toner and drum cartridges.

- Do not unpack a cartridge until you are ready to install it.
- Store cartridges at a constant temperature within a range of 23°F to 95°F (-5° to 35° C.), as well as a humidity range of 10% to 80%.

Common questions

We're here to help you!

The *Muratec Information System* is available to you 24 hours a day, 7 days a week. You can use your fax machine to call this “fax-on-demand” system and receive printouts of information, such as the most common questions asked about your machine. Often, *this* is the fastest way to find out the answer to any question you may have. And it's a free call!

To use the Muratec Information System:

- 1** On your fax machine, press **MONITOR/CALL** to get a dial tone, or lift your optional handset.
- 2** Call **1-800-215-1698**.
- 3** Follow the voice instructions you'll receive from the system.

General questions

- Q:** Where do I add ink or toner to make my fax machine's printouts darker?
- A:** *You can't adjust the darkness of an incoming fax printout, but you can adjust the darkness of a copy or of a transmission. Insert a document and press **CONTRAST** to adjust the contrast setting. “Dark” prints at the darkest setting. The machine will reset automatically to normal contrast after you finish copying or sending the fax.*
- Q:** When I unplug my machine or if the power goes off, will I lose the information I've stored — such as my TTI, autodialer entries, the time and date, etc. — and have to re-enter them?
- A:** No. There's a special battery built into your fax machine which protects user settings for several days if power fails or if you decide to move your machine. However, we do advise you to restore power to the machine as soon as possible.
- Q:** Can I use a dust cover on my fax machine?
- A:** No! A dust cover blocks air circulation, which could cause your machine to over-heat.

Sending faxes

- Q:** Sometimes, I try to send a fax while using either the optional handset or the **MONITOR/CALL** feature. But, when the other side answers, I hear a horrible screeching sound, so I hang up. What's happening?
- A:** That was the other fax machine trying to say “Hello” to your machine! You'll hear sounds like that any time you call a fax machine which is set to answer automatically (as when you set your machine to Auto Answer mode). It's by using these tones that fax machines are able to send faxes over ordinary phone lines. So, next time you hear the tones, press **START** (and, if you're using an optional handset, hang up) to send a fax.
- Q:** I just sent a fax. However, the number that appeared in my machine's display during the transmission wasn't the number I dialed. Why?
- A:** That number you saw is programmed into the remote fax machine by the user. Some users prefer different numbers to appear than the ones they're really using. And some people don't know how to change the number once it's set.
- Q:** Can I transmit and receive at the same time?
- A:** No. Use the call request feature (see pages 2.34–2.35) to ask the person at the remote fax machine if he or she wants to transmit or receive after your fax communication is complete.
- Q:** Do I have to dial a *1* for a long-distance call?
- A:** Yes. Dialing a fax number is just like dialing any other phone number, so be sure to include any special long-distance codes or dialing pauses when dialing. Also, remember to include them when you set your autodialer numbers.
- Q:** How do I send a fax to an overseas telephone number?
- A:** Dialing requirements for international calls may vary depending on your local telephone company's requirements. For most international calls, call *011*, then dial the appropriate country code, city code and phone number. (You may find country and city codes in the front section of your telephone directory.)
- Q:** Can I transmit if my fax machine runs out of paper?
- A:** Yes, but confirmation reports (see page 2.30) aren't available when you transmit without recording paper in your fax machine.

- Q:** Can I transmit a document that's extra long?
- A:** Yes, *if* the receiving fax machine is equipped to handle long documents. Many machines have a special setting which allows them to receive documents that exceed the normal length.
- Q:** Can I transmit a page from a newspaper?
- A:** No. A newspaper page can jam in your document feeder. First, use a copy machine to make an appropriately sized copy of the newspaper page, then transmit the copy.
- Q:** Can I transmit a page with correction fluid on it?
- A:** Yes, but only if the fluid is *completely dry* before you begin transmission.
- Q:** How can I be sure my fax was received?
- A:** Set your machine to print a confirmation report after each transmission (see pages 2.30).
- Q:** I don't want to install a dedicated phone line for my fax machine, so I've connected the machine to a PBX phone system. When I get a fax call, *all* the phones ring. How do I prevent this?
- A:** Call your PBX manufacturer or telephone company for assistance. They may be able to convert one of the PBX lines for use only by your fax machine.
- Q:** Sometimes when I dial a fax call by using either the optional handset or **MONITOR/CALL**, I don't hear the fax receiving tones from the other machine. Am I doing something wrong?
- A:** When this happens, try pressing **START** (and then hanging up the optional handset if you're using it), as usual. It's possible you're calling an older, non-standard fax machine that *doesn't* emit answering tones. Even a few Group 3 faxes (see "Glossary," page 3.18) on the market sound a *sending* tone but don't sound a *receiving* tone. After you transmit, call the person at the other fax machine's location to see if that person got your document.
- Q:** I inserted a document in the feeder and dialed a fax number, but my machine didn't transmit the document. Instead, "**** Auto Redial ****" now appears on my LCD. What does this mean?
- A:** The remote fax machine was busy, so your machine will try the call again, automatically. As long as it hasn't stored more than 99 delayed commands (counting automatic redials), your machine should still accept commands from you. If it has exceeded this quantity and will accept no more commands, try cancelling one of the delayed commands (see pages 2.18). If the machine *still* won't cooperate, keep cancelling commands until it does.

- Q:** The specifications (page A1.1) list an average per-page transmission time, but when I transmit a page it can take much longer. Why?
- A:** We base this specification on transmission of an industry-standard test document called *ITU-T Test Document 1* (sometimes also called the "Slerexe letter"). Fax manufacturers use this method to test transmission speeds. However:
- The pages you send may be darker, or otherwise contain more information, than ITU-T Test Document 1.
 - The transmission time measured for test documents doesn't include *handshake time* — the time during which two fax machines "introduce" themselves to each other and "agree on" the parameters of the call.
 - The specification time is based on the use of normal resolution mode. You may be using fine, superfine or grayscale transmission, each of which takes longer than normal mode.
- Q:** What's a *default*?
- A:** A default is a setting that your machine will always refer to if nothing else is programmed. For example, you can set the default for this machine to send a fax by using its memory. If you set this action as the default, that's how your machine will always send a fax, until you tell it to do differently.

Reports

- Q:** I called the number *011-555-555-1212*, but not all of the digits appear on my transmit confirmation report (TCR). Why didn't the whole number appear? How can I be sure my document went to the right location?
- A:** The numbers you enter using the fax keypad are temporarily stored in a memory "buffer", and it's only the last part of the phone number that the buffer "remembers." An easy way to avoid getting incomplete telephone numbers on your printouts is to store your most frequently used numbers as one-touch keys or speed-dial numbers. These autodialer numbers will appear in their entirety on your TCR.

Receiving faxes

- Q:** My fax never answers. What's wrong?
- A:** Check to make sure your fax machine is properly connected to a working AC power outlet and phone jack (see page 1.12). If you're using a second phone with your machine, make sure *it's* connected properly (page 1.14).
- Q:** Sometimes when I answer my machine with the optional handset, I hear a beeping sound that repeats every few seconds. Is this a fax?
- A:** Yes. When you hear these *fax tones*, someone is trying to send you a fax. Next time, press **START** and hang up the handset. Your fax will receive the message.
- Q:** Does my fax machine have to be plugged in to the AC power jack to receive a message?
- A:** Yes. Your phone will ring if the phone line is connected, but you can't receive a fax unless your fax machine is plugged into both the phone jack and the AC power jack. Make sure your fax machine is always plugged in so you never miss an important fax message.
- Q:** Can I receive a fax if I'm using the phone on my machine?
- A:** You can receive a fax from the person to whom you're talking. When that person has a document ready in his/her machine's feeder, press **START**.

Working with your answering machine

- Q:** People have complained that they call my fax machine and hear my answering machine's message, but are cut off before they can send a fax. What happened?
- A:** Any remote fax machine attempting to send a fax must "hear" responding fax tones within 40 seconds after the person at that machine presses the start key. That 40 seconds includes getting the dial tone, dialing the number, "listening" to the pause before the ringing starts and the remote fax machine answering the ring. Only after that time does your message play. That's why we urge you to create a short outgoing message. The shorter the waiting period, the more likely it is that the remote fax machine will proceed with the transmission. Please create an outgoing message on your answering machine that's no longer than 10 seconds (see page 1.27 for a suggestion).

Polling

- Q:** What's the purpose of polling?
- A:** Polling lets you automatically "pull" a document which is set in another fax machine. You can poll whenever you need to retrieve information and don't want the source to pay for the phone call. With polling, you pay for the call and get the information you need.

How your fax machine works

How a fax machine works is simple:

You put a page into your fax machine's feeder and call a fax number. Your machine makes a satisfactory connection with the other machine, and then ...

- *Your machine takes the document.*
An image scanner in your fax machine examines the information on the page.
- *Your machine wraps the document.*
Your fax machine translates the scanned information into a numeric code and compresses the code for the fastest possible transmission speed.
- *Your machine sends the document.*
Finally, your fax machine sends the compressed code.

On the other end of the line ...

- The remote fax machine *receives* the code.
- Your machine *unwraps* the document.
The remote fax machine uncompresses and deciphers the code, turning it into a representation of the scan your machine made.
- The remote fax machine prints the representation.

The only difference between a regular telephone call and a fax call is the *content* of the transmission:

- On a regular call, your telephone sends your voice.
- On a fax call, your fax machine sends a coded image.

The way fax machines work is regulated closely by the International Telecommunications Union (ITU), an agency of the United Nations. The standards the ITU applies ensure the compatibility of your fax machine with millions of other machines worldwide. However, they also limit the way you can use your machine with other devices, such as telephones and answering machines.

Glossary

This glossary contains terms you may encounter when discussing or reading about fax machines. Please use these definitions for reference only. A list of definitions can also be found on the Muratec website at www.muratec.com.

24-hour format — Also called *military format*. A format for keeping time that does not use a.m. or p.m. to distinguish between morning and afternoon. In the 24-hour format, one o'clock in the morning marks 1:00, noon marks 12:00 and midnight marks 24:00. To calculate the 24-hour format, add 12 hours to all times after noon.

For example, 1:30 p.m. would be 13:30 in the 24-hour format; 10:45 p.m. would be 22:45 in the 24-hour format. And 11:15 a.m. would be 11:15 in the 24-hour format.

A3, A4, B4 — Standard stationery sizes defined by the International Standards Organization, an agency of the United Nations. See also *Paper sizes*.

ADF — Automatic document feeder. See *document feeder*.

Alternate number — The number your machine dials after all attempts to the regular number fail. The user programs this alternate number, if so desired.

Answering machine — See *TAD*.

Autodialing — Enables user to store preprogrammed telephone numbers in the unit's memory. Storage capability varies from unit to unit.

Automatic fallback — The ability of a fax machine to slow down ("fall back"), when communicating with another fax which is communicating at a slower rate.

Automatic reduction — Many Muratec fax machines will automatically reduce the size of documents being transmitted to accommodate the effective printing width of the receiving unit. For example, this allows a fax machine with a 10" scanning width to send an image 10" wide to a unit with an 8.5" print width. The receiving fax machine will receive a reduced-size printout of the complete image.

Bit — The smallest unit of information in a computer. Some Muratec fax machines, which are actually computers "dedicated" to telecommunications, allow users to change bits of information to provide or cancel features through software settings.

Bits per second — See *bps*.

Black density — Also called *black coverage*. The amount of non-white area on a page. For example, most regular office correspondence has a black density well under 10%, due to the presence of margins, spaces between words, spaces between lines and paragraphs and even spaces within letters. However, drawings and photographs have a much higher black density, sometimes approaching 100%. The higher a page's black density, the more slowly a fax machine sends it.

Broadcast — A fax transmission in which a single document is sent to more than one location.

bps — Bits per second. Used to express the speed of transmission of data. Because fax transmission treats a document as a graphic image rather than as a series of alphabetic and numeric characters, bps does not correspond to the number of characters transmitted per second.

Byte — A group of digital elements, usually sent as eight bits to the byte.

Call reserve — Also called *call request*. An ITU-T standard fax feature which allows a user to request voice communication prior to, during or after transmission.

Call-waiting service — An optional telephone company service that alerts you to another incoming call when the phone is already in use. Call-waiting signals often cause interruption of fax transmission or reception.

Caller ID — Optional service provided by your local telephone company that allows you to see a display of the number (phone or fax) that is calling.

CCITT — See *ITU-T*.

CCD, CIS — Charged coupled device, contact image sensor. Two types of scanning mechanisms used in some Muratec fax machines. The CCD "reads" fluorescent light bouncing off a document. The CIS uses a flat bar of light-emitting diodes (LEDs).

Command queue — The "list" your machine keeps of all its pending commands.

Command number — The number your machine gives to each "job" it is programmed to complete. You must know the command number in order to cancel or change any of the machine's jobs that it stores.

Compatibility — The term "compatible" describes the ability of separate things to function together. Your Muratec fax machine features ITU-T Group 3 compatibility, the modern standard for worldwide communication.

Confidential transmission — See *SecureMail*.

Confirmation report — See *RCR* and *TCR*.

Continuous polling — See *Polling*.

Copy mode — Allows your fax machine to be used as a convenience copier.

Cover page (automatic) — A small, user-created message; can be the first page of every transmission.

Database polling — See *Polling*.

Data compression — Used in digital fax machines to speed transmission. See also *Digital fax, MH* and *MSE, SMSE*.

Default — The setting your machine will always refer to if no other action has been programmed. For example, you can set the default for this machine to send a fax by using its memory. If you set this action as the default, that's how your machine will always send a fax, until you tell it to do differently.

Delayed command — Transmission or polling operation set by the user to occur later, automatically, at a predetermined time. Great for reducing costs by making fax calls during times when telephone costs are lowest, such as late at night or on weekends.

Digital — Using the binary system (which uses a combination of *0s* or *1s*) to describe everything, so that *0* means *off* and *1* means *on*; digital fax machines convert the graphic image of your document into a series of zeros and ones by using the binary system of transmission to encode black and white occurrences. This increases transmission speed by passing over white spaces. See also *White-line skip*.

Digital fax — Unlike analog systems that scan every portion of a document, digital fax machines survey a document's overall picture content. Digital fax machines scan a line and convert the information into a binary code of zeros and ones. The fax machine takes this information and compresses it, providing high transmission speeds. Many Muratec units offer proprietary methods for faster transmissions between Muratec-manufactured units (see also *MSE, SMSE*).

DIP switches — Dual in-line package switch; a two-position on/off switch. Many Muratec fax machines include DIP switches to control optional settings or features.

Document feeder — The adjustable slot into which users place documents for faxing or copying.

Effective printing width — The widest image that can be printed on a fax.

Effective scan width — The maximum width the scanner in a fax can scan during transmission.

F-Code — A fax-industry standard created by the ITU-T for sub-addressing/password-based communications. Because F-Code is an industry standard, Muratec fax machines as well as all ITU-T equipped fax machines from other manufacturers can communicate with each other using sub-addressing.

Facsimile (or fax) — A form of communication involving the scanning and decoding of a document into electrical signals and transmitting of the document, over telephone lines to another device. This device then reconstructs the signals to produce an exact duplicate of the document. Also, a machine that performs such communication.

Fallback — Group 3 fax machines operate at the highest transmission speed possible on a given telephone line. Muratec systems offer automatic fallback; if line quality drops during transmission, the fax machine will reduce speed to the fastest possible level.

File number — A number the machine gives to each document it stores for a batch, F-Code or polling operation.

Fine resolution — 203H × 196V lpi. Also shown as *G3F* ("Group 3 fine") on some fax units.

Grayscale — Not a level of resolution, but a method of scanning and transmitting halftone images. Fax machines with grayscale abilities interpret photographs in levels of gray between white and black. The transmitting fax machine must have grayscale ability to send a photographic image accurately, but the receiving machine does not need it to print the image.

Group 3 — Refers to fax machines that use digital encoding. These units transmit one page in less than one minute and produce resolution of 203 × 98, 203 × 196, or 406 × 392 lpi.

Halftone — See *Grayscale*.

Handshaking — An exchange of data between telecommunications and/or computer equipment that "introduces" two systems to each other. For example, faxes use a handshaking protocol to identify the ITU-T group of each unit and to begin fax communication.

Hub — See *Relay broadcasting*.

Hz (or Hertz) — A measure of frequency equal to one cycle per second. Used in the specifications for a fax machine, it identifies the AC power the unit requires.

ITU-T — International Telecommunications Union – Telecommunications Sector. (Formerly known as *CCITT*, for *Consultative Committee for International Telegraph and Telephone*.) A telecommunications forum for member countries of the United Nations whose Study Group XIV established the primary groups for fax equipment, covering communication protocol and transmission. Muratec Group 3 fax machines offer the fastest transmissions allowed by the ITU-T when communicating with other Group 3 units.

ITU-T Test Document 1 — Also called the *Slerexe* ("*slehr-rehks*") letter; An ITU-T standard document with a known black density which fax makers often use to test transmission speeds of their fax machines. Published transmission speeds are also based on this document.

ITU-T v.29 and v.27 ter. — A standard set of communication procedures allowing fax machines to talk to all other units adhering to those standards.

JBIG — Joint Bi-level Image experts Group, the new ITU-T standard image data compression method. As JBIG compresses the data more efficiently than MMR, it is especially effective when transmitting halftone (grayscale) image document. (Of course, the compression ratio may vary with the image data.)

Laser printing — A plain-paper printing system. Toner is attached to a charged drum and an image is transferred onto plain paper through electrical currents, then fused with heat and pressure to produce a dry, permanent printout.

LCD — Liquid crystal display. Used on some Muratec units for status displays.

Leased line — See *Private line*.

Load number — A number assigned to telecommunications equipment used in Canada; designed to help prevent overloading on a telephone circuit. See also *Ringer equivalence number*.

Location ID — See *Station ID*.

lpi — Lines per inch. The way fax image resolution is measured. (For example, see *Normal resolution*.)

Memory — Internal document storage. In Muratec fax machines, random access memory in the form of computer chips is used to store and hold documents for transmission and to hold some documents that have been received.

Memory overflow — A message that appears on the machine's LCD when the current operation requires more of the machine's electronic memory than what is available.

MH — Modified Huffman, the standard ITU-T Group 3 data compression method. A one-dimensional coding scheme that compresses data in a horizontal direction only. A feature of all Muratec fax machines, MH assures transmissions faster than one page per minute when communicating with other Group 3 units, regardless of manufacturer. See also *MR, MMR, MSE, SMSE*.

Military format — See *24-hour format*.

Modem — Modulator-demodulator. A device that converts digital data, like information from a fax machine, into an analog signal for transmission over ordinary telephone lines. A modem is included in a fax machine and allows it to be connected directly to a PSTN telephone line.

MR — Modified Read, an ITU-T Group 3 standard data compression method. A two-dimensional coding scheme that compresses data in both horizontal and vertical directions and allows for faster transmission when communicating with other Group 3 units, regardless of manufacturer. See also *MH, MMR, MSE, SMSE*.

MMR — Modified Modified Read, an ITU-T Group 3 standard data compression method. A two-dimensional coding scheme that compresses data in both horizontal and vertical directions and allows for faster transmission when communicating with other Group 3 units, regardless of manufacturer. See also *MH, MR, MSE, SMSE*.

Monitor — A speaker in most Muratec fax machines which allows the user to hear the dialing process. This is not a speakerphone, because it has no microphone for speaking to the person being called. For regular two-way voice communication, users must use the optional handset. See also *On-hook dialing*.

MSE, SMSE — Muratec's proprietary data compression methods, allowing a Muratec-manufactured fax machine to transmit more quickly when communicating with another Muratec-manufactured unit. MSE and SMSE are features on many Muratec fax machines. See also *MH, MR, MMR*.

Normal resolution — Shown as "norm"; 203H × 98V lpi. The default resolution mode for all Muratec fax machines.

One-touch dialing — Allows the fax user to store frequently used fax numbers for dialing with the touch of one key. See also *Autodialing* and *Speed-dialing*.

On-hook dialing — Dialing numbers by using the keypad on the fax unit without lifting a handset. On most Muratec fax models, the user can do this either silently or by using the monitor. See also *Monitor*.

Original document size — The largest (or smallest) document that can be fed safely through a fax machine.

Override — To change existing settings.

Paper sizes — All are width × length:

Letter-sized = 8.5" × 11.0" (216 × 279 mm)	Legal-sized = 8.5" × 14.0" (216 × 356 mm)
A5 = 5.8" × 8.3" (148 × 210 mm)	B5 = 7.2" × 10.1" (182 × 257 mm)
A4 = 8.3" × 11.7" (210 × 297 mm)	B4 = 10.1" × 14.3" (257 × 364 mm)
A3 = 11.7" × 16.5" (297 × 420 mm)	

Passcode — A four-digit code-number. On your fax machine, the protection passcode lets the user limit access to fax operations, as well as certain settings and even documents readied for polling (in the case of polling, only calling machines whose users enter the proper passcode will be able to poll the document.)

PBX (or PABX) — Private branch exchange; privately-owned telephone equipment serving a particular building, business or area. Many PBX systems use digital transmission lines which, unlike more common PSTN lines, are not compatible with fax machine use. The user should not connect a fax unit to a PBX without first checking with the system manufacturer or service representative.

PCL — Page Control Language. An industry standard for printer control. Some Muratec fax machines include or offer PCL-compatible printing for Windows-based personal computers.

Platen — A traditional copier-style top to a fax machine or digital copier. Some Muratec fax machines and multifunctional products include a platen top, allowing you to fax from books and other awkward sources.

Polling — Automatic transmission to a calling remote fax, or reception of a document from a remote fax set for this operation. Polling is convenient whenever a central unit must receive information from one or several remote faxes. The caller bears all telephone charges and prevents several remote units from calling at the same time. See also *Secure polling*.

Private line — (Or *leased line*.) A service offered by many telephone systems; provides an exclusive phone circuit between two geographic points. A Muratec fax does not require a private line. See also *PSTN*.

Proprietary — Non-standard. In fax, refers to a fax feature which works only in communications between fax machines that are the same brand.

PSTN — Public switched telephone network; the most common type of telephone lines and service in use, in contrast to private or leased lines. A Muratec fax provides fast, reliable data transmission over a PSTN line, and does not need a special or dedicated telephone line. See also *Private line*.

QuadAccess[®] — Muratec's QuadAccess allows your Muratec fax machine to perform four or more tasks simultaneously without slowing.

RCR — Receive confirmation report. An RCR is your assurance that the document you transmitted was received. The RCR prints after your transmission, identifying the receiving unit and recording the date, time, transmission mode, number of pages sent and the result. The RCR is an exclusive feature of Muratec fax machines and is available only when transmitting to other, compatible Muratec fax machines. See also *TCR*.

Receiver ID — See *Station ID*.

Redialing — The dialing again, either manually or automatically controlled, of the most recently dialed fax or phone number. Automatic redialing follows an unsuccessful dialing attempt and can be done manually or automatically.

Relay broadcasting — Lets some Muratec fax machines store a document in internal memory, transmit the document to the memory of a remote “hub” fax and then instruct that unit to relay (re-transmit) the document to each fax in a call group in the “hub” unit. This feature speeds extremely high-volume fax communication and allows a single command to initiate document transmission to hundreds of preprogrammed fax locations. It also saves phone charges for the originating machine. Your machine can initiate a relay broadcast.

Remote fax machine — The machine on the other “end” of a fax communication.

REN — See *Ringer equivalence number*.

Resolution — The resolution of documents transmitted or copied by fax machines is measured by the number of horizontal (H) and vertical (V) lines per inch (LPI) the unit can print. A Muratec unit may offer one or more of these resolution levels:

Normal	203H × 98V lpi
Fine	203H × 196V lpi
Superfine	203H × 392V lpi

Some Muratec units also offer grayscale transmission (see also *Grayscale*) for accurate reproduction of photographs and other shaded originals.

Ringer equivalence number — Also called *REN*. A number assigned to telecommunications equipment used in the United States; designed to prevent overloading on a telephone circuit. See also *Load number*.

Scanning width — See *Effective scanning width*.

SecureMail — Allows a Muratec fax user to send a document to or receive one into (usually something confidential) an “electronic mail box.” The transmission is protected at the receiving Muratec fax by an access code; the receiving fax prints the document only when an authorized user enters the code.

Secure polling — Polling in which preset passcodes are checked between two machines before polling is allowed to take place.

Speed-dialing — Allows the fax user to store frequently used fax numbers for dialing with the touch of three keys — an identifier key (either * or #) and then a three-digit code — for each number. See also *Autodialing* and *One-touch dialing*.

Station ID — (Also called *Location ID* or *Receiver ID*.) An autodialer feature which lets the fax user enter a descriptive name to correspond with the number in an autodialer entry. For example, rather than entering only *1-972-555-3465*, the user can enter that number and a name, such as *Dallas Branch Office*. (Many Muratec models with this feature allow entry of both upper-case and lower-case letters, for greater ease of reading.)

Subaddressing — An ITU-T standard allowing fax machines to specify special delivery characteristics of a transmission. For example, subaddressing allows fax machines from different manufacturers to send and receive messages into confidential memory mailboxes, or to retrieve specific files from polling memory.

Subscriber ID — A fax machine’s telephone number, as identified by a user setting. See *TTI*.

Super Group 3 — An extension of Group 3 fax technology standards, allowing the use of high-speed v.34 bis modems for 33.6 Kbps transmission and high-speed protocols for rapid handshaking.

Superfine resolution — 203H × 392V lpi. Your Muratec fax machine’s superfine transmission mode is Group-3-compatible, not the more limited proprietary version.

TAD — Telephone answering device, or answering machine. Records incoming voice messages for playback. You can connect a TAD to a Muratec fax machine and use the two on one phone line.

TCR — Transmit confirmation report; this provides proof that your Muratec fax did send the document you set for transmission. Printed after transmission, the TCR also identifies the telephone number to which the fax sent the document, plus the actual time of transmission and how many pages the unit transmitted. See also *RCR*.

Thermal (paper) printing — A thermal head heats chemically treated, thermally sensitive paper in patterns conforming to the image the machine has scanned, creating a printed image. Thermal paper’s tendency to discolor and fade, in addition to its curliness and the usual difficulty in writing on it, have made this method considerably less popular than plain-paper fax printing — particularly as plain-paper fax machines have dropped sharply in price.

TriAccess — Muratec’s TriAccess allows a Muratec fax machine to perform three or more tasks simultaneously without slowing.

TTI — Transmit terminal identifier. A user-programmable line of information sent automatically with every page a fax machine sends; it appears at the top of each page printed by the receiving unit.

Transmission speed — How fast a fax machine is sending a fax document. This speed depends upon the modem speed of each unit, the resolution setting, the content of the document, the encoding technique and the condition of the phone line (clean, noisy, etc.) Any change in any one of these five conditions will affect the speed, sometimes significantly.

v.29 and v.27 ter — A standard set of communication procedures allowing fax machines to talk to other units using those standards. Specifically, these standards cover fax transmission at 9600 bps or slower.

v.34 — An international standard for fax modems — and other modems — with transmission speeds of up to 28.8 Kbps. The v.34 protocol is sometimes referred to as “v.Fast”, because it represented a significant increase in possible transmission speed compared to the transmission protocol it replaced.

v.34 bis — A faster version of the v.34 standard, and sometimes referred to as “v.34 Plus” or “v.34 +”. The v.34 bis protocol allows transmission at up to 33.6 Kbps, and represents the current maximum standard transmission speed possible under ITU-T Group 3. (The term “bis” is French, and designates the “second” version of the protocol.)

White-line skip — A technique used to speed up fax transmission by bypassing redundant areas, such as white space.

This page intentionally blank.

Appendix and index

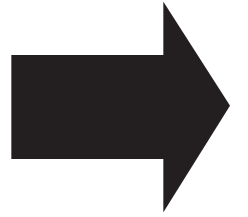

Specifications

General

Type:	Desktop plain paper facsimile
Compatibility:	ITU-T Super Group 3, Group 3
Phone System:	Public Switched Telephone Network (PSTN) or equivalent
Dual access:	Multitasking
One-Touch Dial:	72 locations
Speed Dial:	128 locations

Operating Environment

Environmental Temperature:	50° F to 89.6° F (10° C to 32° C)
Relative Humidity:	20 to 80% RH

Power requirement: Power: 120v ± 10%, 50–60 Hz.

Power consumption:	Standby	: 19 W
	Maximum	: 1180 W
	Memory Transmit	: 51 W
	Receive	: 830 W
	Copy	: 840 W

Communication

Coding Method:	ITU-T-standard JBIG, MMR and MR, Murata-proprietary MSE.
Modem speed:	33,600, 31,200, 28,800, 26,400, 24,000, 21,600, 19,200, 16,800, 14,400, 12,000, 9,600, 7,200, 4,800, 2,400 bps
Error Correction Mode:	Yes
Memory Capacity:	8MB, Option 8MB (Maximum 16MB)
Memory Backup Time:	(Total memory capacity: Backup time) 8MB : 120 hours 16MB: 60 hours (Must be charged for at least 48 hours to reach full charge)

Polling/Broadcasting:	230 locations / 230 locations
Transmission speed:	2.85 seconds per page.*

Document input

Document Set:	ADF :Face Up FBS :Face down
Original reference position:	ADF :Center FBS :Front right corner
Scanning Resolution:	(horizontal × vertical): Transmission: Normal 203 × 98 dpi Fine 203 × 196 dpi Superfine 406 × 392 dpi** Grayscale 203 × 196 dpi (Memory Tx) 406 × 392 dpi** (Feeder Tx)
	Copy: Normal 203 × 98 dpi Fine 203 × 196 dpi Superfine 406 × 392 dpi Grayscale 406 × 392 dpi
Reading Method:	Flatbed CCD
Scanning width:	11.6 inches***, 9.9 inches or 8.2 inches; user-selectable
Document size :	(width × height) ADF; single sheet: Maximum 12.0 inches × 35.4inches, Minimum 4.7 inches × 3.9 inches ADF; two or more sheets : Maximum 11.7 inches × 16.5 inches, Minimum 5.8 inches × 4.1 inches FBS Maximum 10.1 inches × 14.3inches
ADF capacity:	50 letter-sized sheet, 25 legal-sized sheet or 15 ledger-sized sheet (20lb bond paper)
Document thickness:	35–104.7 g/m ² (13–24 lb.)

Appendix and index

Scanning speed:****	Normal: 1.9 sec/page (Tx) Fine: 1.9 sec/page (Tx), 1.9 sec/page (Copy) Super Fine: 3.8 sec/page (Tx), 3.8 sec/page (Copy) Grayscale: 1.9 sec/page (Tx), 3.8 sec/page (Copy)
Grayscale:	256-level in feeder Tx or copy, 64-level in memory Tx

Document output

Print destiny:	406 dpi (horizon) × 392 dpi (Vertical)
Warm-up time:	Within 20 sec.
Paper exit system:	Face up exit system
Printing method:	LED scanning, Electrophotographic Dry Powered Image Transfer to plain paper
Effective print width:	210 mm (8.3 inches)
Effective print length:	Letter 10.7 inches, Legal 13.7 inches
Print speed:	12 ppm (Based on letter-sized paper)
Reduction Print:	Auto (Variable from 100% to 50% by 1% ratio) Fixed (100%, 97%, 91%, 81% or 75%)
Reduce and enlarge:*****	Variable from 50% to 200% by 1% ratio Fixed (200%, 129%, 78%, 64% or 50%)
Smoothing Print:	Yes
Paper type:	Ordinary plain paper 60–90 g/m ² (20–24 lb)
Printing paper size:	Paper cassette; Letter or Legal Multi paper tray; Letter, Legal or Half-letter
Paper capacity:	Paper cassette; 400 sheets Multi paper tray; 1 sheet
Receiving paper tray capacity:	150 sheets

Miscellaneous

Weight:	75.2 pounds (34.2 Kg)
Dimensions :	Width 20.9 × Depth 24.2 × Height 15.2. (inches)
Drum cartridge life:	20,000 pages
Toner cartridge life:	10,000 pages (4% coverage) Based on 4% document coverage and continuous printing.

* Based on transmission of ITU-T Test Document 1 to a Muratec fax machine. Your transmission times will vary, but your Minolta fax machine always will provide the fastest transmission speeds possible under ITU-T guidelines and phone-line conditions.

** In the case that the remote fax has the ability of "406 × 392".
If not, the superfine resolution is "203 × 392", and the grayscale resolution in feeder transmission is "203 × 196".

*** Using ADF only.

**** Based on letter-sized sheets (width × length, 8.5" × 11" (216 mm × 279 mm)).

***** Only for Copy mode

Regulatory information

United States of America

Federal Communications Commission (FCC) information

Ringer Equivalence Number (RENS): AC REN, 0.5B; DC REN, 0.3.

This facsimile machine has been tested and found to comply with the limits for a Class A digital device, pursuant to Part 15 of the FCC rules. These limits are designed to provide reasonable protection against such interference in a residential installation.

This equipment generates, uses and can radiate radio frequency energy and, if not installed and used in accordance with the instructions, may cause harmful interference to radio communications. However, there is no guarantee that interference will not occur in a particular installation.

If this equipment causes interference in radio or television reception (which can be determined by turning the equipment off and on), the user is encouraged to try to correct the interference by one or more of the following measures:

- Reorient or relocate the receiving antenna.
- Increase the separation between the equipment and receiver.
- Connect the equipment into an outlet on a circuit different from that to which the receiver is connected.
- Consult the dealer or an experienced radio/TV technician for help.

This equipment complies with Part 68 of the FCC rules. On the bottom of this equipment is a label that contains, among other information, the FCC registration number and REN for this equipment. If so requested, you must provide this information to the telephone company.

An FCC-compliant telephone cord and modular plug are provided with this equipment. This equipment is designed to be connected to the telephone network or premises wiring using a compatible modular jack which is Part-68-compliant.

Telephone company procedures

The goal of the telephone company is to provide you with the best service it can. In order to do this, it may occasionally have to make changes in its equipment, operations or procedures. If these changes might affect your service or the operation of your equipment, the telephone company will give you notice, in writing, to allow you to make any changes necessary to maintain uninterrupted service.

If you have any questions about your telephone line, such as how many pieces of equipment you can connect to it, the telephone company will provide this information upon request.

In certain circumstances, it may be necessary for the telephone company to request information from you about the equipment which you have connected to your telephone line. Upon request of the telephone company, provide the FCC registration number and the Ringer Equivalence Number (REN) of the equipment which is connected to your line. Both of these numbers are listed on the equipment label attached to your fax machine.

The sum of all RENS on your telephone line should be fewer than five (5) in order to assure proper service from the telephone company. Sometimes, a sum of five (5) may not be usable on a given telephone line.

Note: This equipment is hearing-aid-compatible (HAC).

Notice: The Telephone Consumer Protection Act of 1991 makes it unlawful for any person to use a computer or other electronic device to send any message via a telephone fax machine unless such message clearly contains, either in a margin at the top or bottom of each transmitted page or on the first page of the transmission, the date and time it was sent and an identification of the business or other identity, or other individual sending the message and the telephone number of the sending machine or such business, entity or individual. For instructions on programming this information (the "TTI") into your fax machine, see pages 1.15–1.16.

Type of service

Your fax is designed for use on standard-device telephone lines. The fax connects to the telephone line with a standard line called the USOC RJ-11. Connection to telephone-company-provided coin service (central-office-implemented systems). Connection to party line service is subject to State tariffs.

If problems arise

If any of your telephone equipment is not operating properly, you should immediately remote it from your telephone line, as it may cause harm to the telephone network. If the telephone company notes a problem, they may temporarily stop service. When practical, they will notify you before this disconnection. If advance notice is not feasible, you will be notified as soon as possible. When you are notified, you will be given the opportunity to correct the problem and will be informed of your right to file a complaint with the FCC.

In the event repairs are ever needed on your fax machine, they should be done by Muratec America, Inc., or an authorized representative of Muratec America, Inc. For information, contact the Muratec Customer Support Center at 972-364-3350 (from the U. S. only).

Canada

Industry Canada (IC) regulations

IC Ringer Equivalence Number (REN): 0.4.

This digital apparatus does not exceed the Class A limits for radio noise emissions from digital apparatus as set out in the interference-causing equipment standard entitled "Digital Apparatus," ICES-003 of the Department of Communications.

Cet appareil numérique respecte les limites de bruits radioélectriques applicables aux appareils numériques de Classe A prescrites dans la norme sur le matériel brouilleur: "Appareils Numériques," NMB-003 édictée par le Ministre des Communications.

Notice: The Canadian Department of Communications label identifies certified equipment. This certification means the equipment meets certain telecommunications network protective, operational and safety requirements. The Department does not guarantee the equipment will operate to the user's satisfaction.

Before installing this equipment, users should ensure that it is permissible to be connected to the facilities of the local telecommunications company. The equipment must also be installed using an acceptable method of connection. Sometimes, the company's inside wiring associated with a single-line individual service may be extended with a certified connector assembly (telephone extension cord). The customer should be aware that compliance with these conditions may not prevent degradation of service in some situations.

Repairs to certified equipment should be made by an authorized Canadian maintenance facility designated by the supplier. Any equipment malfunction, or repairs or alterations made by the user to this equipment, may give the telecommunications company cause to request the user to disconnect the equipment.

Users should ensure for their own protection that the electrical ground connections of the power utility, telephone lines and internal metallic water pipe system, if present, are connected. This precaution may be particularly important in rural areas.

Caution: Users should not attempt to make such connections themselves, but should contact the appropriate electric inspection authority or electrician.

The Ringer Equivalence Number (REN) assigned to each terminal device provides an indication of the maximum number of terminals allowed to be connected to a telephone interface. The termination on an interface may consist of any combination of devices subject only to the requirement that the sum of the RENS of all the devices does not exceed 5. The IC REN for your equipment is 0.4.

Limited warranty

This warranty is made by Muratec America, Inc. (hereafter referred to as "Muratec"). This warranty is valid only on Muratec products purchased and used in the United States of America. This warranty applies to the product only while owned and used by the original purchaser ("Customer"). If ownership of the product is transferred, this warranty terminates. This warranty does not apply to any product in use for rental purposes.

This Muratec product is warranted against defects in material and workmanship for ninety (90) days commencing the date of original Customer purchase. If the product is defective in material and/or workmanship (normal wear and tear excepted) during the warranty period, Muratec or its authorized representative will, during Muratec's established service availability hours, make necessary adjustments and repairs, including, at Muratec's option, installation of replacement parts. Muratec's service availability hours are 8:30 AM to 5:00 PM (Central time) Monday through Friday, excluding Muratec-recognized holidays. Muratec will complete the necessary adjustments and repairs within a reasonable time period, as dictated by the nature of the problem and by Muratec's service schedule. Replacement parts may have been used and/or reconditioned. Parts that have been replaced will remain the property of Muratec. This warranty is subject to the OBLIGATIONS and EXCLUSIONS set forth.

Obligations

1. This warranty will be honored only on presentation of the original dated authorized Muratec bill of sale or Muratec dealer bill of sale or sales slip to an authorized Muratec service representative or service center. For the name of your authorized service center, contact Muratec (from the United States, call 1-972-364-3350; from Canada, check your in-box materials for the number to call).
2. During the warranty period, the Customer must notify Muratec by telephone of any defective product material and/or workmanship.
3. Transportation (including prepayment of freight and insurance charges) of the product to and from an authorized service center, designated by Muratec, is the responsibility of the Customer.
4. If Muratec provides maintenance or responds to a call which is outside the scope of this warranty, such maintenance shall be billed to the Customer at Muratec's then-current rates for maintenance and parts and shall be due and payable in full upon receipt of invoice.

Exclusions

1. This warranty shall not cover a product with missing or altered original identification marks.
2. This warranty applies only to products that the purchaser has properly installed, adjusted and operated in accordance with the instructions set forth in or provided with product literature. This warranty does not apply to any product which has been subjected to tampering, alteration, misuse, abuse, neglect, improper installation or transportation damage. Nor does it apply to costs for any service requested for demonstration or to confirm proper operation of this product.
3. The warranty shall not apply to adjustments, repairs or replacements necessitated by any cause beyond the control of Muratec (whether foreseeable or not) including, but not limited to, any malfunction, defects or failure caused by or resulting from any of the following: improper unpacking or installation, unauthorized service or parts, or improper maintenance or cleaning, modification or repair by the Customer, accident (including, without limitation, unavoidable accidents), fire, flood or other Acts of God, improper telephone or electrical power or surges thereof, interconnection with or use of non-compatible equipment or supplies (including paper), or placement of the product in an area which does not conform to Muratec space, electrical and/or environmental requirements.
4. Muratec will not be required to make adjustments, repairs or replacements if the product is installed or used at a location deemed by Muratec to be hazardous to health or safety, or if Muratec is not provided with free and reasonable access to the product and a telephone during service availability hours, or if the product location is not accessible by an authorized Muratec service vehicle.

EXCEPT AS EXPRESSLY SET FORTH ABOVE, AND EXCEPT TO THE EXTENT PROHIBITED BY APPLICABLE LAW, MURATEC MAKES NO OTHER WARRANTIES, EXPRESS OR IMPLIED (INCLUDING, BUT NOT LIMITED TO, ANY IMPLIED WARRANTIES OF MERCHANTABILITY OR FITNESS FOR A PARTICULAR PURPOSE, AND ANY WARRANTY ARISING FROM COURSE OF DEALING OR USAGE OF TRADE), AND MURATEC EXPRESSLY DISCLAIMS ALL WARRANTIES NOT STATED HEREIN. IN THE EVENT THE PRODUCT IS NOT FREE FROM DEFECTS AS WARRANTED ABOVE, THE CUSTOMER'S SOLE REMEDY SHALL BE REPAIR OR REPLACEMENT AS PROVIDED ABOVE. UNDER NO CIRCUMSTANCES SHALL MURATEC BE LIABLE TO THE CUSTOMER, OR TO ANY USER, FOR ANY DAMAGES, INCLUDING ANY INCIDENTAL OR CONSEQUENTIAL DAMAGES, EXPENSES, LOST PROFITS, LOST SAVINGS OR ANY OTHER DAMAGES ARISING OUT OF THE USE OR INABILITY TO USE THE MURATEC PRODUCT, EVEN IF MURATEC OR ITS REPRESENTATIVES HAVE BEEN ADVISED OF THE POSSIBILITY OF SUCH DAMAGES.

Some States do not allow the exclusion or limitation of incidental or consequential damages, and some States do not allow limitations on how long an implied warranty lasts, so the above limitations or exclusions may not apply to you. This warranty gives you specific legal rights, and you may also have other rights which vary from State to State.

Index

- A**
- Automatic document feeder (ADF) 1.3
 - Auto answer light 1.4
 - Alarm light 1.4
 - Activity journal 2.29
 - Autodialer 2.7-2.15
 - One-touch numbers 2.8-2.11
 - Speed-dial numbers 2.11-2.14
- B**
- Book-cover 1.3
 - Batch transmission 2.20
 - Block Junk Fax 2.60-2.61
 - Broadcasting 2.16
- C**
- Communication light 1.4
 - Call groups 2.8-2.15
 - Printing a call group directory 2.14
 - Call request 2.34
 - Canceling commands 2.18
 - Caring for your fax machine 3.12-3.13
 - Clearing paper jams 3.1-3.3
 - Closed network 2.60
 - CODE key, setting 2.2
 - Confirmation stamp 2.5
 - Contrast 1.17, 2.1
 - Copy 1.28
 - Copy protection 1.31
 - Enlargement or reduction 1.31
 - Making copy settings 1.28
 - Using the ADF 1.29
 - Using the FBS 1.29
 - Using the Multi paper tray 1.30
 - Cover page 2.28-2.37
- D**
- Date and time, setting 1.15
 - Delayed transmission 2.17
 - Printing a delayed command list 2.19
 - Printing a stored document 2.19
 - Reviewing or canceling delayed commands 2.18
 - Department codes 2.62-2.63
 - Distinctive ring detection (DRD) 2.33
 - Document, guidelines 1.17
 - Drum cartridge, installing 1.8-1.9
- E**
- EasyDial 1.32, 2.15
 - EasyStart 1.15-1.16
 - ECM 2.4
 - Error messages 3.6-3.9
- F**
- Flatbed scanner (FBS) 1.3
 - Fax Forward 2.35-2.37
 - F-Code communication 2.38
 - an introduction 2.38
 - Bulletin box 2.42-2.45
 - Creating or modifying 2.38-2.42
 - Erasing an empty F-Code box 2.45-2.46
 - F-Code transmission and polling 2.46-2.47
 - Printing a list of F-Code boxes 2.42
 - Relay box 2.45
 - Security box 2.44-2.45
- G**
- Glossary 3.17-3.20
 - Grayscale 1.1, 1.17
- H**
- Half-page reception 2.3
- I**
- Image Rotation 2.3
- J**
- Jammed paper, removing 3.1-3.3
 - Journal 2.29
- L**
- Liquid crystal display (LCD) 1.2

Appendix and index

Language settings	2.6
Location ID	2.7

M

Memory receive light	1.4
Machine setting list	2.6
Macros	2.25-2.37
Multi paper tray	1.3

N

Number of rings	2.4
Numbering pages	2.35

O

One-touch numbers	2.8-2.11
Out-of-paper reception	1.27

P

Paper jam light	1.4
Passcode	2.56
Phone	1.32
Attaching a second phone	1.14
Attaching an optional handset	1.13
Using your fax machine as a phone	1.32
PIN mask	2.57-2.59
Polling	2.31
Being polled	2.32
Continuous polling	2.32
Regular polling	2.31
Print quality problems	3.4-3.5
Print settings	2.2
Print reduction rate	2.2
Reduction margin	2.3
Printing machine setting	2.6
Programmable one-touch keys	2.48-2.55
Erasing a programmable one-touch key	2.54-2.55
Fax dialing with programmable one-touch	2.54
Printing a list of your programmable one-touch keys	2.55
Programming a batch transmission	2.51
Programming a broadcast / group	2.49-2.50
Programming a delayed transmission	2.48-2.49
Programming an F-Code transmission	2.52-2.53
Programming F-Code polling	2.53-2.54
Programming regular polling	2.50-2.51

Q

QuadAccess®	2.37
Quick Memory transmission	2.31

R

Replace paper light	1.4
Receiving faxes	1.24
Review Commands	1.23
an introduction	1.23
Redialing	1.22, 1.32
Reception modes	
Ans/Fax Ready mode	1.26-1.27
Fax Ready mode	1.25
Fax/Tel Ready mode	1.25
Tel Ready mode	1.24
Tel/Fax Ready mode	1.26
Regulatory information	A1.3
Reports	2.30
Receive confirmation report (RCR)	2.30
Transmit confirmation report (TCR)	2.30
Resolution	1.1, 1.17, 2.1
Rings, setting number on which to answer	2.4

S

Setting up	1.7-1.14
Adjust the monitor speaker's volume	1.13
Attach the paper-handling parts	1.9
Attaching a second phone	1.14
Attaching an optional handset	1.13
Installing the printing supplies	1.8
Loading paper	1.10
Setting for legal-sized paper	1.10
Plug in and power up	1.12
Removing the transport screws	1.7
Turn off the transport mode	1.12
Scan settings	2.1
Primary contrast	2.1
Primary resolution	2.1
Scanning width	2.1
Scanner cover	1.3
Scanning width	2.1
Security features	2.56-2.63
Security reception	2.56-2.59
Sending faxes	1.17-1.23
Guidelines	1.17
Using memory transmission	1.18
Using monitor/call or a handset	1.21
Using the ADF	1.19
Using the FBS	1.20
Setting security transmission	2.59
Silent mode	2.4
Soft Keys	2.24-2.37
Special Dialing Characters	2.7

Special features 2.24-2.37
Specifications AI.1-AI.2
Speed-dial numbers 2.11-2.14
Storing the toner and drum cartridge(s) 3.13
Subscriber ID 1.16, 2.59, 2.60

T

Toner cartridge, installing 1.8-1.9
Transferring documents 2.35
Transmission 1.17-1.23
Transmit Terminal Identifier (TTI) 1.15
Transport mode 1.12
Troubleshooting 3.6-3.11
 Error messages 3.6-3.9
 Errors 3.9-3.11

V

Volume setting for monitor speaker 1.13

W

Warranty, limited AI.4

This page intentionally blank.

This page intentionally blank.

This page intentionally blank.