

Konica

FAX 9930



User's Manual

Every effort has been made to ensure that the information in this handbook is complete, accurate, and up-to-date. Konica Business Technologies, Inc. assumes no responsibility for the results of errors beyond its control. Konica Business Technologies, Inc. also cannot guarantee that changes in software and equipment made by other manufacturers and referred to in this handbook will not affect the applicability of the information in it. Mention of software products manufactured by other companies does not necessarily constitute endorsement by Konica Business Technologies, Inc.

Copyright 2000 by Konica Business Technologies, Inc. All Rights Reserved

First Edition: February, 2000

Written and produced by the Konica Business Technologies Inc. Training and Publications Department.

Please address any comments on this publication by mail to:

Konica Business Technologies, Inc.
Marketing Department
500 Day Hill Road
Windsor, CT 06095

Manual Part Number OP-9930-01

Please visit Konica Business Technologies Inc's. multilingual web site at:

<http://www.Konicabt.com>

ENERGY STAR is a registered trademark of the United States Environmental Protection Agency.

Windows is either a registered trademark or a trademark of Microsoft Corporation in the United States and/or other countries



As an ENERGY STAR® partner, Konica Business Technologies, Inc. has determined that this product meets the ENERGY STAR guidelines for energy efficiency.

Contents

Help and Helpful Hints	1	Introduction	11
Where is the Help Key?	2	Konica Web Site	11
What Does Help Do?	2	Features	12
Help List	3	Getting to Know Your Machine	14
Function List	3	Components	14
Saving Money	4	Control Panel Keys and Indicators	19
Saving Time	6	One-Touch Keypad	24
Help Button	6	Accessing Second Panel of One-Touch Keys	26
Speed Dial Numbers	6	Signal Tones	26
DualAccess	6		
www.konicabt.com	6		
Helpful Hints	7		
Send a Fax and Save the Number	7		
Checking Information During Transmissions	8		
References	9		
Recording Addresses and Passwords	10		

Installation	27	Selecting Functions and Settings	40
Safety	28	Navigating the Function Menu	41
Installation Hints	28	Primary Menu Functions	41
Operation and Maintenance	29	Using the Help Key	42
Toner Cartridge and Image Drum Handling	29	Setting Features	42
Toner Emergency First Aid	30	Using Step Access	43
Getting Started	30	Using Speed Access	44
Where to Install Your Fax Machine	30	Speed Access Numbers	44
Unpacking	31		
Setting Up Your Fax Machine	32		
Installing the Toner Cartridge	34		
Attaching the Document Stacker	36		
Connecting to the Telephone Line	36		
Connecting Optional External Devices	37		
Handset	37		
Telephone	37		
Answering Machine	38		
Answering Machine and Telephone	38		
Connecting Power	38		
Loading Paper	39		

Setting Basic Features	48	Dial and Incoming Call Parameter Settings	53
Setting the Date and Time	48	Setting Dial and Incoming Call Parameters	53
Setting the Language	48	Dial Parameter Settings	54
Setting Your Fax Machine's ID	49	Redial Tries	54
TSI/CSI	49	Redial Interval	54
Sender ID	49	Auto Start	54
Setting the TSI/CSI and Sender ID	49	Dial Tone Detect	54
Setting the Answering Mode	50	Busy Tone Detect	55
Procedure	50	Tone/Pulse (MF/DP)	55
List of Modes	50	Tone (MF) Duration	55
Auto Receive Mode [FAX]	50	PBX LINE	55
Manual Receive Mode [TEL]	51	FLASH/EARTH/NORMAL	56
Telephone/Fax Mode [T/F]	51	DIAL PREFIX	56
Telephone Answering Device Mode [TAD]	51	Incoming Call Parameters	57
Memory Reception Mode [MEM]	52	Incoming Ring	57
Forwarding Mode [FWD]	52	Remote Receive	57
PC Fax Mode [PC]	52	Continuous Tone	58
		PC/FAX Switch	58

Other Basic Parameters	59
Monitor Volume	59
Buzzer Volume	59
User Language	59
Paper-Size Setting	60
Connecting to a PBX.....	60
Entering a PBX Dial Prefix	61
Clearing the PBX Dial Prefix	61

Programming Speed Dial Numbers	62
Types of Speed Dial Numbers	63
One-Touch Speed Dials	64
2 or 3 Digit Speed Dials	65
Group Faxing	65
Programming One-Touch and 2 or 3 Digit Speed Dial Numbers	66
Collect Information	66
Program the Information	68
Programming a Speed Dial	71
Clearing a Speed Dial	73
Chain Dialing	74
Creating a Chain Dial Number	74
Dialing the Chain Dial Number	74
Programming a Group	75

Basic Faxing	76		
Document Guidelines	76	No Paper Reception	87
General	76	No Toner Reception	87
Single Page Specifications	77	Receiving Faxes to Memory	88
Multiple Page Specifications	77	When Are Faxes Received to Memory?	88
Loading Documents	78	When Are Memory Messages Printed?	88
Resolution	79	Memory Message Limitations	89
Contrast	79	Active Memory Files Report	89
Sending a Fax	80	Printing the Active Memory Files Report	89
Using a One Touch Speed Dial Key	80	Printing Messages Stored in Memory	90
Using 2 or 3-digit Speed Dial	80	Canceling Messages Stored in Memory	90
Using the Search Function	81	Erasing Messages Received in Memory Without Printing Them	90
Using the Numeric Keypad	81	Messages in Memory and Power Losses	91
Using An External Telephone	81	Power Outage Report	91
Rejecting Unsolicited Fax Messages	82	Dual Access	92
Closed Network	82	What You Can Do While Making Copies	92
Setting a Closed Network	82	What You Can Do While Sending a Fax	93
Power Failures	83	What You Can Do While Receiving a Fax	94
Power Outage Report	83	Making Copies	95
Display Messages	84	To Make Copies	95
Basic Faxing Situations	85	Manual Paper Feeder	96
Real-Time Dialing	85	Face Up Stacking/Face Down Stacking	97
Redialing	85		
Confirming Results	85		
Stopping a Transmission	86		
Receiving Faxes Manually	86		

Sending a Fax to Multiple Locations 98

Group vs. Broadcast 98

Group Faxing 100

 What is a Group Fax? 100

 Programming a Group 101

 Deleting and Groups 102

 Sending a Fax to a Group 103

 Finding a Group Name 103

 Group Directory Report 103

 Using Speed Dial/Search 104

Broadcasting 105

 What is a Broadcast Fax? 105

 Sending a Broadcast Fax 105

Advanced Operations	106		
Delayed Faxing	107	Confidential Faxes	115
What is Delayed Faxing?	107	Programming Personal (Confidential) Mailboxes	116
Delayed Fax vs. Delayed Batch	107	Creating a Personal (Confidential) Mailbox	117
Sending a Delayed Fax	108	Changing a Password	118
Canceling Delayed Transmissions	109	Closing a Mailbox	119
Delayed Batch Transmission	110	Sending Confidential Faxes	120
Program the Delayed Batch Destination Number	110	Receiving Confidential Faxes	121
Setting the Batch TX Time Function	111	Knowing You've Received a Confidential Fax	122
Send a Fax as Part of a Delayed Batch	112	Confidential Reception Report	122
Canceling Delayed Batch Transmissions	113	Printing Confidential Faxes	122
Priority Transmission	114	Deleting Confidential Faxes	123
Sending a Priority TX	114	Call Forwarding	124
		Set a Forwarding Number	124
		Set the Auto Answer Mode to FWD	125
		Clear Forwarding Mode	125
		Forward on Paper/Toner Error	126
		Setting a Paper/Toner Error Forwarding Number	126

Relay Faxing	127	Sending Documents Requested by Another Fax Machine	
Using Your Machine as a Relay Initiating Station	128	(Polling Transmission)	137
Relay Password	129	Explanation of Polling Transmission Types	138
Relay Group Numbers	129	Feeder (Document Tray) Polling	140
Relay Key Station (Hub)	129	Memory Polling	141
Contact Number for Relay Broadcast Report.....	130	Setting Memory Polling	141
Relay Broadcast Report.....	131	Memory Polling (Bulletin)	142
Initiating a Relay Broadcast	132	Create a Polling Mailbox	143
Using Your Machine as a Relay Key Station (Hub)	133	Set Bulletin Polling	143
Program the Destination Numbers	134	Printing Polling Documents in Memory	144
Create the Destination Group(s)	134	Dialing Another Fax Machine to Request Documents	
Create the Relay Password	134	(Polling Reception)	145
Status of Relay Broadcast Report	135	Printing Faxes Polled into Memory	146
Printing the Relay Fax at the Hub	136	Cancelling Polled Faxes in Memory	146

Customizing Features and Operations 147

Identifying Current Settings	148
Printing a Configuration Report	148
Changing Operation Functions	149
List of Operation Functions	150
Remote Diagnosis	150
Transmission (TX) Mode Default	150
Memory Full Save	151
Instant Dial	151
Restrict Access	152
ECM Function	152
Sender ID Switch	152
Pulse Dial Rate	153
Pulse Make Ratio	153
Pulse Dial Type	153
T/F Timer Prg.	154
CNG Count	154
Ring Response	154
Distinctive Ring	155
Memory Password	156
Restricted Access ID	157

Service Function Settings	159
Long Document Scanning/Transmission	159
MYD/DMY	159
Time/Date Print	159
TSI Print	159

Reports 160

Understanding Reports	160
Printing Reports	160
Printing a Message Confirmation Report	160
Printing Other Reports	160
List of Reports	161
Printed from the Menu	161
Automatically Generated	161
Activity Report	162
Printing the Activity Report	162
Active Memory Files Report	163
Printing the Active Memory Files Report	163
Broadcast Confirmation Report	164
Printing the Broadcast Confirmation Report	164
Telephone Directory	164
Printing the Telephone Directory	164
Group Directory Report	165
Printing the Group Directory	165
Configuration Report	165
Printing the Configuration Report	165

Function List	166
Printing the Function List	166
Message Confirmation Report	167
Printing the Message Confirmation Report	167
Message Confirmation Report Options	168
MCF (Single-Loc)	168
MCF (Multi-Loc)	168
Image in MCF	168
Err. Report (MCF)	168
Power Outage Report	169
Broadcast Entry Report	169
Confidential Reception Report	169
Codes Used in Reports	170
Result Codes	170
Communication Codes	171

Maintenance	172	Options and Accessories	186
Cleaning the Scanner Path	172	Obtaining	186
Replacing the Toner Cartridge	173	Part Numbers	187
Toner Yield	173	Consumables	187
Replacing the Image Drum	177	Options	187
Image Drum Yield	177	Descriptions	188
Resetting the Drum Counter	179	Second Paper Tray	188
Dual Line	180	Handset	188
What is Dual Line?	180	Multifunction Printer (MFP) PC Interface Kit	188
Benefits of Dual Line	180	600 dpi TX Kit	188
Basic Operations	181	Memory Expansion	189
Unpacking	183		
Connecting to the Second Telephone Line	184		
Displays, Reports, and Beeps	184		
Setting the Option Line Type for the Second Line	185		
Setting Memory Transmissions to Use the Second Line ..	185		

Problem Solving	190	Specifications	209
Printing a Cleaning Page	190	Dialing	209
Clearing a Document Jam	191	General	210
Clearing a Printing Paper Jam	192	Memory	211
Display Panel Messages	196	Scanning	212
Normal Display in Standby Mode	196	Consumables	212
Error Messages	196	Paper Handling	213
Counters	200	Physical	213
Accessing the Print/Scan Counters	200	Electrical	214
Resetting the Image Drum Counter	200	Environmental	214
Problem Checklist	201	Index	215
Shipping Your Machine	208		
United States and Canada	208		
Latin America	208		



Help and Helpful Hints

Your fax machine has many features and capabilities that will help you

- operate the machine
- save money
- save time

The Help button provides valuable information to help you operate the machine.

This section summarizes the features and capabilities directly connected to saving money and time.

Details for these features and capabilities are provided in other sections of this document.

You may want to use some of our Helpful Hints when working with your machine.

Where is the Help Key?

The Help key (1) is a control panel key.

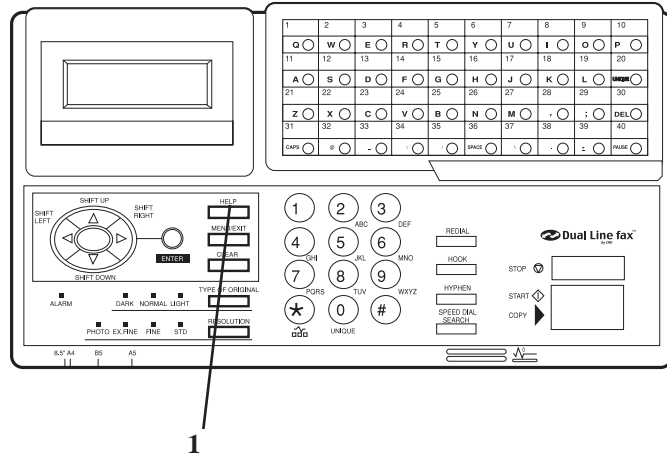

What Does Help Do?

When you press the Help key, a Help List and Function List print.

The Help List is a guide for using key features of the machine. It provides step-by-step instructions for using the control panel to access or program various machine settings and features.

The Function List is a printout of the menu structure. The menu is set up in a multilevel structure of functions, options, and settings. For more information, refer to “Selecting Functions and Settings.”

Help List

The Help List covers the items listed below.

- 1 Program Speed Dial Numbers
- 2 Program Groups
- 3 Sending a Fax to Multiple Locations (Broadcast)
- 4 Sending a Fax to a Single Location
- 5 Copying
- 6 Delayed Faxing
- 7 Function Settings
- 8 Report Printing
- 9 Message Confirmation Report

Function List

The Function List is a report of the product's menu programming structure.

Use it as a reference while moving through the levels of the menu.

It is **NOT** a report of the current menu settings.

The Configuration Report provides a list of the current menu settings.

See "Reports, Configuration Report."

Saving Money

Most phone services offer lower phone rates during off-peak times and for local phone connections.

Your fax machine allows you to take advantage of lower phone rates. Some savings depend on the options you have purchased and the type of fax machines you communicate with.

You can specify the time your outgoing faxes will be sent.

Delayed Transmission

This feature allows you to send documents at a specified time and date.

You do not have to manually start the transmission.

For more information, refer to “Advanced Operations, Delayed Fax Transmissions.”

Relay Faxing

This feature allows you to send documents to one distant fax machine, which then forwards the documents to other fax machines. This reduces the total number of long distance calls.

Here is a typical relay fax situation.

The head office of a company will send a fax to the regional head offices. The regional office will forward the fax to the local branch offices.

For more information, refer to “Advanced Operations, Relay Faxing.”

Control Access to Your Machine

You can control access to your machine. The method you use determines the amount of access control.

- A password must be entered or the machine cannot be used

The machine can only be used by people who have the password. Up to 24 passwords can be programmed.

How could you use this?

If different departments share the machine, each department could have its own password.

For more information, see “Customizing Features and Operations, Changing Operation Functions, Restrict Access.”

- ! ***Be sure to record all passwords. Keep the record in a safe place. If you forget a password, you will need to contact your Authorized Konica Dealer for assistance.***

- The machine will only receive or send transmissions to specified locations.

The fax numbers you program as Speed Dials will be the only numbers your machine communicates with.

For more information, see “Basic Faxing, Rejecting Unsolicited Fax Messages.”

Saving Time

Help Button

Press the Help Button to print a Help List and Function Lists.

These are great references to use while working with your machine.

See “Help and Helpful Hints.”

Speed Dial Numbers

Speed Dial Numbers (One Touch, 2-Digit, 3-Digit) can be programmed with frequently dialed numbers.

This greatly reduces the number of keystrokes and time required when using these numbers.

For more information, refer to “Programming Speed Dial Numbers.”

Dual Access

Your machine can multi-task.

You can load and prepare a document for sending while the machine is receiving or sending another fax.

You do not have to wait for one operation to finish before beginning another.

For more information, refer to “Basic Faxing, Dual Access.”

www.konicabt.com

Konica’s web site, www.konicabt.com, provides the most current information available for your fax machine.

You can find information at your convenience, at any time.

Konica Customer Support

Konica’s Customer Support tel. number is 1-800-825-5664. Our Customer Service Representatives can answer questions regarding basic operating procedures, sales and service referrals and product information. Our representatives are not trained to provide assistance with the use of commercial software packages. Please consult your applications manual for availability of their support.

Helpful Hints

Send a Fax and Save the Number

If you enter a number to send a fax, and want to save it as a Speed Dial number, you can

- 1 Enter the number.
- 2 Place the document on the feeder.
- 3 Press **Speed Dial/Search**.
The machine goes to the next available (not yet programmed) Speed Dial number.
LOC # displays.
- 4 Press **Enter**.
- 5 You are prompted to enter the information for this Speed Dial (Name, Alternate Telephone Number, Communications Speed, and Echo Protection State.
- 6 You may enter all of the requested information or press **Menu/Exit** to return to sending your fax.
- 7 Either wait or press **Start**.
Wait, and the transmission begins in a few seconds.
Press **Start** and the transmission immediately begins.

- ! *Be sure to write the name for any Speed Dial numbers you program on the One Touch Sheet(s).*

The One Touch Sheet(s) provide space for Speed Dial numbers 1 through 80. For Speed Dials 81 and above, program the number(s) and print the Telephone Directory. For more information, see “Reports, Telephone Directory.”

Quick Message Confirmation Report

To quickly print the Message Confirmation Report for the most recent transmission performed by the machine, press ENTER twice.

Checking Information During Transmissions

Your fax machine allows you to check the progress of a fax being sent by your machine.

Press the # key twice while a fax is being sent from your machine.

The display will show

- the page number currently being sent
- the current modem speed
- the current compression method

References

There are four very useful reference documents that you should print and keep near your fax.

These documents are very helpful when programming your machine.

1 Help and Function Lists

Press Help and these lists print.

The Help List provides instructions for using the control panel to access or program various machine settings and functions.

The Function List is a printout of the menu structure. It **IS NOT** a report of current menu settings.

See “Help and Helpful Hints.”

2 Configuration Report

The Configuration Report is a list of the current operational settings of your machine.

See “Reports, Configuration Report.”

3 Telephone Directory

This report provides a complete listing of all of the telephone numbers programmed into your machine’s Speed Dial numbers.

See “Reports, Telephone Directory.”

4 Group Directory

This report provides a complete listing of all of the numbers programmed into a specific group. Each group has an individual report.

See “Reports, Group Directory Report.”

Recording Addresses and Passwords

- ! *Be sure to record any addresses and passwords you program. Keep the record in a safe place. If you forget a password, you will need to contact your Authorized Konica Dealer for assistance.*

Some of the features that use addresses and passwords are:

- Confidential Faxes
See “Advanced Operations, Confidential Faxes.”
- Relay Faxes
See “Advanced Operations, Relay Faxing.”
- Restrict Access
See “Customizing Features and Operations, Changing Operation Functions, Restrict Access.”

Introduction

Thank you for purchasing this fax machine. This desktop, plain-paper facsimile machine utilizes advanced light-emitting diode (LED) technology for quick and trouble-free transmission/reception of data and images. In addition to the many standard features, options can expand the machine's capabilities.

For information on the options, see "Options and Accessories."

Konica Web Site

The Konica Web Site provides the most current information available on your product.

An on-line version of this document is available for viewing via Konica's Web Site.

You may reach the Konica Web Site at: www.konicabt.com

Features

The machine includes the following features:

- **Help Button.** Pressing this button causes the unit to print a Help List and the Function List.
- **Control panel.** Special programming keys, a 40-key plate for pre-programmed telephone numbers, and a 10-key pad for standard dialing and programming.
- **80-character display (4 rows of 20 characters).** Easy to read display for operation guidance, clock display, function information, etc.
- **Automatic Document Feeder (ADF).** Capacity of up to 50 sheets of recommended letter/A4 paper.
- **Speed Dial.** Set up to 80 pre-programmed telephone numbers for automatic one-touch faxing, as well as an additional 150 numbers for 2 or 3-digit entry faxing.
- **Group Faxing.** Create as many as 20 groups of telephone numbers and send documents to multiple locations with a single selection.
- **Automatic alternate call.** Dials a second (alternative) telephone number if the number originally dialed is busy.
- **Alphanumeric telephone directory.** Search for programmed telephone numbers by name.
- **72-hour battery backup.** If power is lost, messages will in memory will be saved for 72 hours.
- **33.6K bps transmission rate.** Fast, efficient communications.
- **Large-capacity memory.** 4.5 Mbyte. This provides storage capacity of up to 360 pages.
- **Half-tone.** Documents with half-tone areas (shades of gray, usually graphics) are processed with 64-scale gradation (64 levels of gray).
- **Advanced transmission and reception functions.** Includes delayed transmission, broadcasting (multi-location transmission), confidential message transmission/reception, relay broadcasting, polling, etc.

- **Automatic redial and page retransmission.** Ensures document transmission when a telephone number is busy or a problem occurs in the communications process.
- **Advanced memory transmission/reception features.** A number of convenient features including automatic reception into memory without printing—ideal for reception of confidential communications).
- **Dual Access operations.** Allows two tasks to be conducted at once (e.g., scan and prepare a document for transmission while another document is being received).
- **Automatic answering mode detection.** Distinguishes between incoming fax and voice communications. Allows the use of an answering machine on the same telephone line.
- **Closed network.** Prevents the reception of unsolicited communications.
- **Large Paper Capacity.** 250 sheet paper cassette (universal size: legal, letter, A4). A 500 sheet optional second paper tray is available. With the second tray installed, the total capacity of the machine is 750 sheets.
- **Fax forwarding.** Document can be forwarded to a designated location after being stored in memory (setting can also be used to forward a document when the local machine is out of toner or paper).
- **No paper reception.** Allows continued reception of documents when toner or paper run out by storing data not yet printed in the built-in memory.
- **Polling.** Allows the transmission/reception of documents from remote facsimile machines with polling capabilities.
- **Copier function.** Make up to 99 copies of a document at one time.
- **Progress reports.** Enable tracking of transmission status, and machine operations, settings and maintenance requirements.
- **Security Features.** Enables you to control access to your machine and faxes.
 - Confidential Mailboxes (16)
 - Personal Mailboxes
 - Confidential Reception
 - Rejecting Unsolicited (Junk) Fax Messages

Getting to Know Your Machine

Components

Refer to the illustrations for the location of the item(s).

- 1 Display Panel
Displays status of machine and operation in progress
- 2 One-Touch Keypad
Use for one-touch dialing of preprogrammed telephone numbers and for entering alphabetic, numeric and special characters for programming and ID entries.
- 3 Numeric Keypad
Use to enter telephone numbers, program information, and manual dialing.

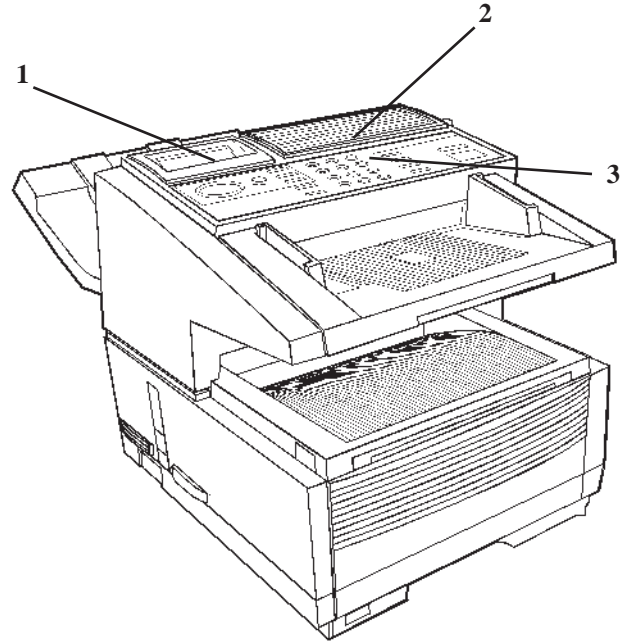

- 4 Manual Paper Feeder Tray
Fold out for manual paper feed (bypass paper tray).
Use this to feed different types of paper directly into the machine.
- 5 Copy Stacker Release Buttons
Press these two buttons (one on each side), to gain entry to the toner/image drum area.
- 6 Power Switch
Press 1 to turn on and 0 to turn off.
- 7 Control Panel (Programming) Keys
These are the main keys used for programming machine settings and operations and navigating through the function menu.
- 8 Document Stacker
Holds original documents after being faxed or copied.
- 9 Document Guides
Adjust guides to the width of documents being faxed or copied.

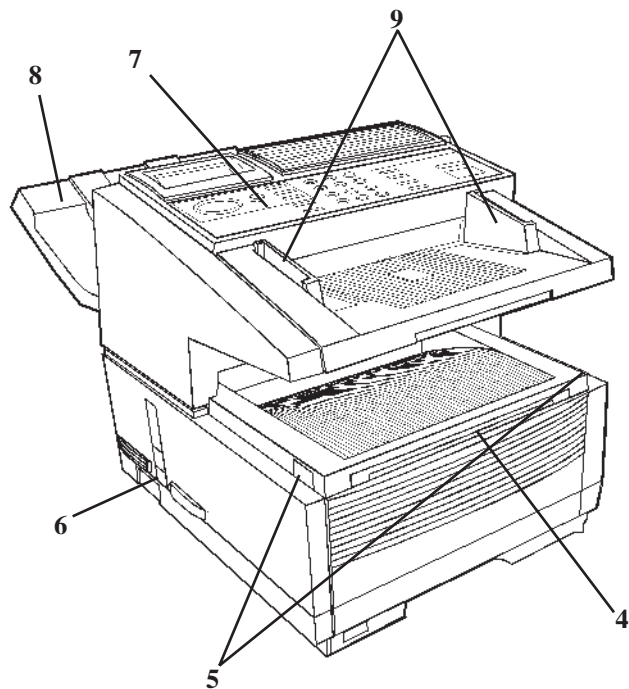

- 10 Document Tray
Holds documents being faxed or copied.
- 11 Document Tray Extension
Pullout extension supports long (length) documents.
- 12 Copy Stacker
Holds document copies after copying process.
- 13 Copy Stacker Extension
Pullout extension for supporting long documents.
- 14 Paper Tray
Holds 250 sheets of paper (universal type: legal, letter, A4)
- 15 Paper Indicator
Shows level of paper remaining in paper tray.
- 16 Copy Output Lever
Up position: copies exit the machine face down.
Down position: copies exit the machine face up.
Use this lever when copying or when using the optional Network Print or PC Print.

! *Options vary according to the the model of your machine. See “Options and Accessories”*

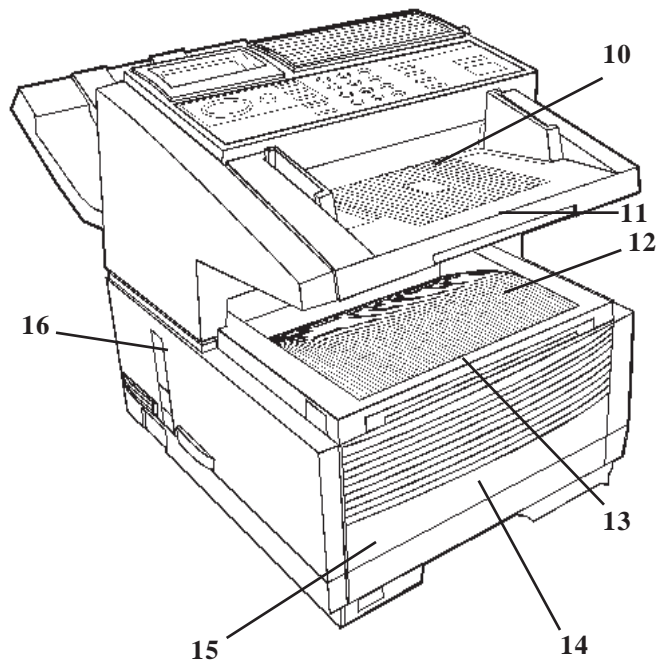

17 AC Power Cord Socket

Plug the AC power cord (supplied with the unit) into this socket.

18 Line Jack

Jack for connection to main outside telephone line.

19 Back Cover

Remove this cover to expose the expansion (installation) slots for certain options.

! *Options vary according to the the model of your machine. See “Options and Accessories”*

20 IEEE-1284 Parallel Port

The optional Multi-Function Printer (MFP) Kit uses this port. The MFP software allows your fax machine to interface with a computer. With the MFP Kit, your fax can function as a printer, scanner, copier and PC-based fax machine. A parallel cable is included in the kit.

! *Options vary according to the the model of your machine. See “Options and Accessories”*

21 and 22

TEL Jack 1 (21) and TEL Jack 2 (22)

Jacks for connecting optional telephone handset, external telephone, or answering machine.

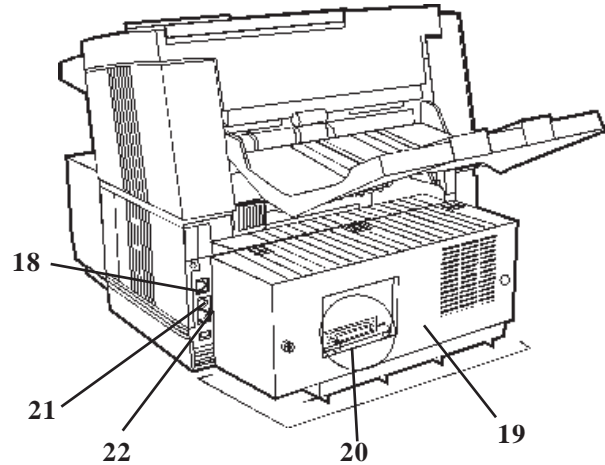
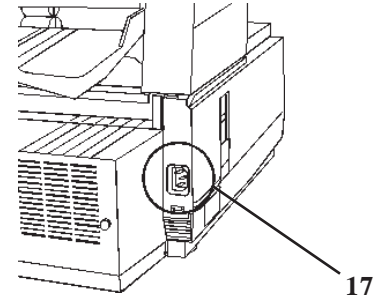

23 LED Printhead

This black bar is the transfer mechanism that writes received/copied information to the image drum.

Clean the LED when you change the toner cartridge.

See “Maintenance.”

24 Image Drum Unit

The image drum contains a green photosensitive drum which receives information from the LED print head and transfers it to the printing paper.

Install a new image drum unit* when **Replace Drum** appears on the display panel.

* Only install image drum units specified by Konica for use in this machine!

See “Maintenance.”

25 Toner Cartridge

This black cylinder, installed inside the image drum unit, contains the black power used as the machine’s ink for printing data.

Install a new toner cartridge* when **Replace Toner Cartridge** appears on the display panel.

* Only install toner cartridges specified by Konica for use in this machine!

See “Maintenance.”

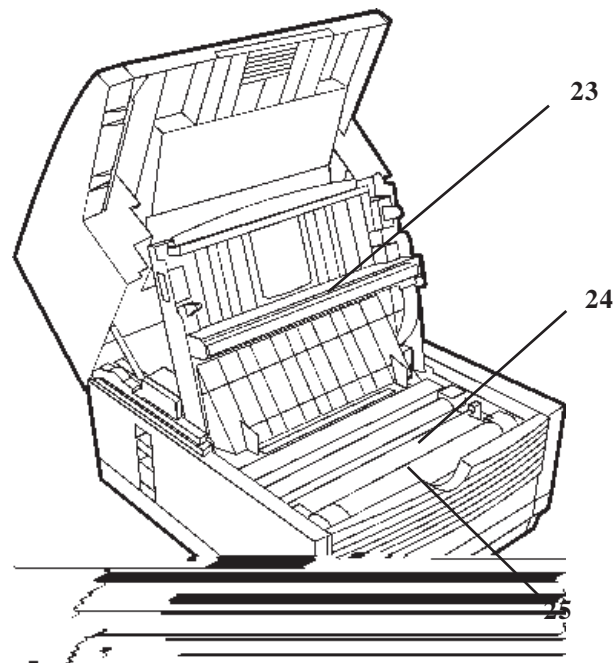

Control Panel Keys and Indicators

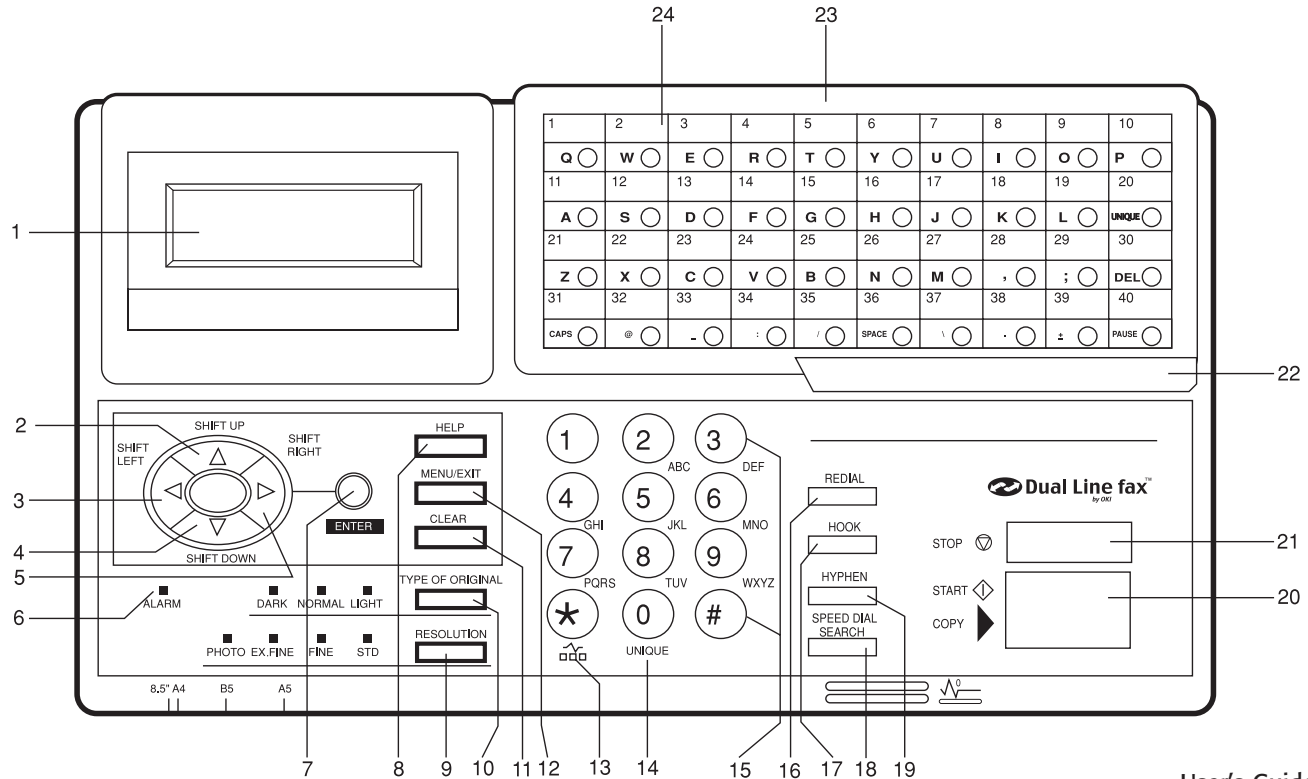

1 Display Panel: Refer to this display for instructions and information while the machine is performing operations, or when entering information or changing settings.

2 Shift Up ▲ Key: Use this key to:

- Move to the previously selected option in the same operational layer when programming the machine.
- Move to the upper row from the lower row when data such as telephone numbers is listed in two rows.

3 Shift Left ◀ Key: Use this key to:

- Return to the previous operational layers in the programming of the machine.
- Move the cursor to the left during normal operation

4 Shift Down ▼ Key:

Use this key to:

- Move to the next option in the same operational layer when programming the machine.
- Move to the lower row from the upper row when data such as telephone numbers is listed in two rows.

5 Shift Right ▶ Key:

Use this key to:

- Move to the next operational layer in the programming of the machine.
- Determine/register a menu option or setting.
- Move the cursor to the right during normal operation.

6 Alarm Indicator: This indicator light flashes and an alarm sounds as an alert for problems that occur. To turn off the alarm indicator, press the **Stop** key and correct the problem.

7 **Enter Key:**

Use this key to:

- Determine/register a menu option or setting.
- Determine the location of a broadcast operation.
- Display the results of a transmission or printout a Message Confirmation Report when the machine is in the standby mode with no document set in the document tray.

8 **Help Key:** Press this key to print out Help and Function lists.

9 **Resolution Key (Photo, Ex.fine, Fine, STD indicator lights):** Use this key to set the desired resolution of the fax/copy after loading the document. Use the Photo setting when the original document includes half-tone images.

10 **Type of Original Key (Dark, Normal, Light indicator lights):** Use this key to set the contrast after loading the document. Use Light for originals that are too light, Normal for originals with good contrast, and Dark for originals that are too dark.

11 **Clear Key:** Use this key to cancel ID, telephone number and programming entries.

12 **Menu/Exit:** Use this key to:

- activate the Menu mode when the machine is in standby state.
- exit the mode and return to standby state.

13 ***/Tone Key:** If the machine is set for pulse dialing, pressing this key will switch from pulse to tone dialing during the current call. This key can also be used during programming to create numbers with mixed pulse-tone operation.

14 **0/Unique Key:** Use this key as “0” when dialing telephone numbers. When programming the Sender ID, Location ID, etc., use this key to enter unique characters:

Symbols: ! # & ‘ () * + , - . / : ; = ? ·

Internet characters: @ “ (space) % ^

The ^ functions as a tilde symbol.

Umlaut characters: Ä ß Ñ Õ Ü

Norwegian characters: Æ Å Ø æ å ø

- 15 Numeric Keypad:** These 12 keys work like the keypad on a standard telephone when dialing a telephone number. They are also used to move to another operation mode, enter numbers, letters and other characters when programming the machine, and input speed dial numbers after pressing the Speed Dial key. The “#” key is used for the creation of groups of telephone numbers for batch transmission. After a document is loaded, this key can also be used to select previously programmed groups of telephone numbers for faxing.
- 16 Redial Key:** Press this key to automatically redial the last telephone number dialed on the machine.
- 17 Hook Key:** Use this key to open the telephone line for manual dialing with the numeric keypad or external telephone handset. After pressing the key, you can hear the dial tone and dialing code through the machine’s speaker.
- 18 Speed Dial/Search Key:** After loading a document for faxing, press this key and then enter the programmed Speed Dial (One-Touch or 2 or 3-digit) number for the location. The speed dialing function automatically dials the telephone number and transmits the fax. After pressing the Search key, you can search corresponding location IDs when alphanumeric characters are entered.
- 19 Hyphen Key:** Use this key as the “-” character when programming ID and PBX, public line, international telephone or Earthing/Flashing switches. It is also used to type the “+” when entering TSI/CSI numbers.
- 20 Start/Copy Key:**
Use this key to:
- Start transmission of a document after loading the document and selecting the location.
 - Start manual fax transmission or reception.
 - Return the machine to normal operation from the Power Save mode.
 - Start the copying function.

21 Stop Key:

Use this key to:

- Cancel the operation shown on the display.
- Cancel the transmission of a fax (press twice within 3 seconds).
- Cancel an alarm (Alarm indicator light illuminates).
- Return to higher operational layers when programming the machine.

22 One-Touch Keypad Latch to Second Panel: Lifting this latch rotates the primary label plate for the One-Touch keypad, revealing a second panel.

! *The One Touch Sheet(s) provide space for Speed Dial numbers 1 through 80. For Speed Dials 81 and above, program the number(s) and print the Telephone Directory.*

See “Reports, Telephone Directory.”

23 One-Touch Keypad: Detailed descriptions of the One-Touch Keypad functions are provided in a different section of this document.

See “Getting to Know Your Machine, One-Touch Keypad.”

24 One-Touch Labels: After programming a telephone number into a One-Touch key, write the name of the location on the label for the One-Touch key. Remove the plastic covering the label, use a pencil to write the name, and then replace the cover.

You may need replacement (blank) labels.

See “Options and Accessories, Obtaining.”

One-Touch Keypad

Use these keys for quick, one-touch dialing and the programming of other machine operations. In addition to the ability to assign telephone numbers (up to 40 digits each) to a One-Touch key, alphanumeric names of up to 15 characters in length can be registered (Telephone Directory).

Using One-Touch Keys for Dialing

To use One-Touch keys for dialing, after the telephone number(s) for the key have been programmed, simply load the document to be faxed and press the key of the location where the fax is to be sent. Two telephone numbers can be programmed for each One-Touch key, a primary number that is always dialed first, and an alternate number that is automatically dialed if the first number is busy or the call is not answered.

Using One-Touch Keys for Search

After pressing the Search key, use these keys to make an alphabetical search for names of telephone numbers previously programmed.

Using One-Touch Keys for Programming

The One-Touch keys are also useful in the programming of names in the machine memory. In addition to the alphanumeric keys, a number of special keys are provided for programming convenience:

Alphabet Keys (One-Touch keys #1-27, except #20): When programming the Sender ID and Location ID, use these keys to enter alphabet characters.

Unique Key (One-Touch key #20): Use the same as the “0” of a 10-key pad. Also used to enter

Symbols: ! # & ‘ () * + , - . / : ; = ? ·

Internet characters: @ “ (space) % ^

The ^ functions as a tilde symbol.

Umlaut characters: Ä ß Ñ Ö Ü

Norwegian characters: Æ Å Ø æ å ø

Del Key (One-Touch key #30): Use this key to delete characters at the position of the cursor in the display panel when entering ID, telephone numbers or programming functions.

Caps Key (One-Touch key #31): Use this key to switch between uppercase and lowercase when entering alphanumeric characters.

Space Key (One-Touch key #36): Use this key to enter spaces when programming the machine. Unlike the Pause key, spaces provide easier reading only and have no effect on dialing characteristics.

Plus Key (One-Touch key #39): Each fax number entered or programmed into the machine can be up to 40 digits long. If you need to dial a number longer than 40 digits, you can dial the number using any combination of Speed Dial numbers or the numeric keypad.

To enter a chain dial number into a Speed Dial number, press the Plus key at the 40th position of the first part of the number to indicate it is a chain dial number, then complete the process by entering the second part of the number following the procedures required for inputting another Speed Dial number.

Pause Key (One-Touch key #40): Use this key to enter automatic 3-second pauses in dialing when programming telephone numbers. For example, use this key to tell the machine to wait for an outside or international line to open. Pauses in a telephone number dialing sequence are indicated by a “P”.

Other: Special character keys (, ; @ _ : / \ . +).

Accessing Second Panel of One-Touch Keys

To access the second panel of One-Touch keys (41-80), grasp the latch at the bottom of the keypad and lift up on the main panel, swinging it up and to the right. After pressing the desired key(s), close the main panel.

- ! *The One Touch Sheet(s) provide space for Speed Dial numbers 1 through 80. For Speed Dials 81 and above, program the number(s) and print the Telephone Directory.*

See “Reports, Telephone Directory.”

Signal Tones

The machine emits sounds to identify specific conditions.

Key Select Tone: This is a short beep that is emitted each time a key is pressed.

Error Tone: If an inappropriate key is pressed, the machine emits three short beeps. If there is a problem with operations during communications, the machine emits five long beeps. Press the **Stop** key to stop the beeping (turn the error tone off), and then print a Message Confirmation Report to check the source of the problem. To print the report, press the **Enter** key twice (with no documents loaded).

End of Session Tone: At the end of each successful faxing session, the machine emits a long beep to confirm that there were no errors or problems in the communication.

Off-Hook Alarm Tone: If the machine is equipped with a telephone handset, and if the receiver of the handset is left out of the cradle when not in use, the machine emits an intermittent warbling sound. To turn off the sound, return the receiver to its cradle or press the **Stop** key.

Installation

To install your fax machine, follow the steps in this section.

- Safety
 - Installation Hints
 - Operation and Maintenance
 - Toner Cartridge and Image Drum Handling
 - Toner Emergency First Aid
- Getting Started
 - Where to Install Your Fax Machine
 - Unpacking
- Setting Up Your Fax Machine
 - Installing the Toner Cartridge
 - Attaching the Document Stacker
 - Connecting to the Telephone Line
 - Connecting Optional External Devices
 - Handset
 - Telephone
 - Answering Machine
 - Answering Machine and a Telephone
 - Connecting Power
 - Loading Paper

Safety

Installation Hints

- Install your fax machine in a dust-free location away from direct sunlight
- Do not plug your fax machine into a power source shared by equipment that produces electrical noise (e.g., air conditioners).
- Leave electronic adjustments to authorized service personnel
- The LINE terminal connects your fax machine to a standard telephone line. To avoid damage to your telephone system or to the fax machine, do not plug your fax machine into anything other than a standard RJ-11C jack.
- Your fax machine is intended to be grounded electrically and is equipped with a three-wire grounded power cord. For your safety, do not attempt to defeat your power cord's grounding plug.
- The electrical outlet and phone jack should be installed near the equipment and should be easily accessible.
- The two TEL terminals on the back of the fax machine are only suitable for 2-wire devices. Not all standard telephones will respond to incoming calls when connected to an extension jack.
- This equipment may not necessarily provide for the effective hand-over of a call from a telephone connected to the same line.
- The operation of this equipment on the same line as telephone or other equipment with audible warning devices (such as call waiting) or automatic ring detectors may cause false tripping of the ring detector.

Operation and Maintenance

- Use a dry cloth to clean the control panel and the main body of the unit.
- Aside from the instructions specifically mentioned in this document, your fax machine is not user serviceable. Do not attempt to service the machine or lubricate moving parts by yourself.
- Pull out the AC plug before trying to remove any objects that may have fallen into the machine.
- Immediately disconnect the fax machine if it becomes physically damaged and arrange for its repair or disposal.
- When relocating your fax machine, always disconnect the telephone line before disconnecting the power cord, then reconnect the power cord first.
- This fax machine is not intended to be used in parallel with any other telephone devices.

Toner Cartridge and Image Drum Handling

- Leave unused toner cartridges and image drums in their packages until needed. When replacing a toner cartridge or image drum, re-use the packaging to dispose of the old toner cartridge or image drum.
- Do not expose these components to light for more than five minutes. Never expose the green drum (inside the image drum unit) to direct sunlight.
- Always hold the image drum by the ends—never by the middle. Never touch the green drum inside the image drum unit.
- Exercise care when removing the toner cartridge. Do not let it touch your clothing or porous materials. The toner powder causes permanent stains.
- Small amounts of toner spilled on skin or clothing can be readily removed with soap and cold water. Using warm water will make removing the stain much more difficult.

- “See next page for Toner Emergency First Aid”

Toner Emergency First Aid

- **Eye:** Flush eyes with plenty of water. If symptoms occur, get medical attention.
- **Skin:** Wash with water and mild soap
- **Ingestion:** Wash out mouth with water. Drink one or two glasses of water, if symptoms occur, get medical attention.
- **Inhalation:** Remove victim to fresh air. If symptoms occur, get medical attention.

Getting Started

Where to Install Your Fax Machine

Place your fax machine in a dust-free location away from direct sunlight.

- Allow several inches on each side of the fax machine to ensure adequate ventilation.
- Make sure that both power and telephone outlets are available nearby.
- Choose a location where the relative humidity is between 20% and 80%, and where the temperature is between 50°F (10°C) and 92°F (32°C).

Unpacking

Remove contents from the carton. Be sure that all the items listed below are included.

- ! *If any items are missing, contact Konica immediately.*
- *Keep your packing materials and carton in case you need to ship or transport the unit.*

- 1 Fax Machine
- 2 Toner cartridge
- 3 Image drum (inside machine)
- 4 Power cord
- 5 Telephone line cord
- 6 Document Stacker
- 7 Documentation
 - User's Manual
 - Warranty Information

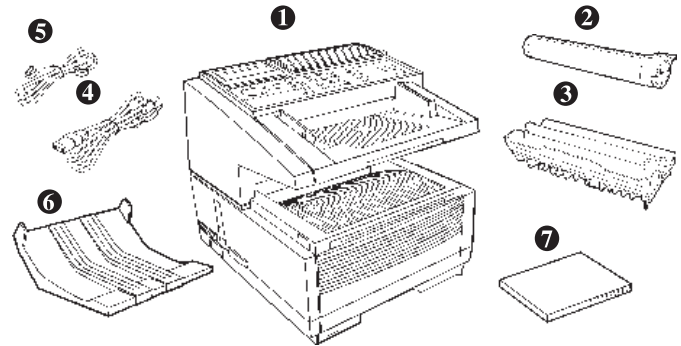

Setting Up Your Fax Machine

1 Lift up on the document tray and swing it up and out of the way.

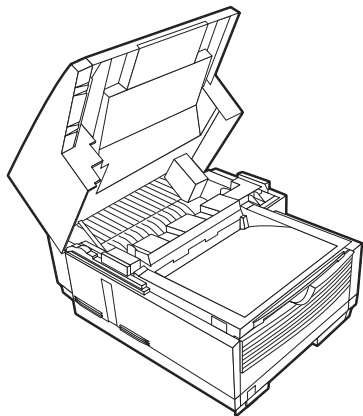

2 Press the release buttons located on both sides of the copy stacker. Lift up the stacker.

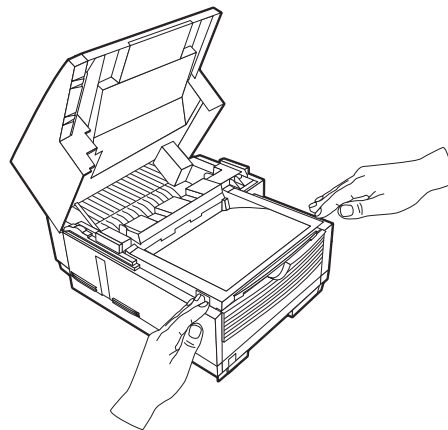

- 3 Move aside the protective sheet and grasp the image drum cartridge, then lift it out.

! **Caution: Do not touch the green drum surface!**

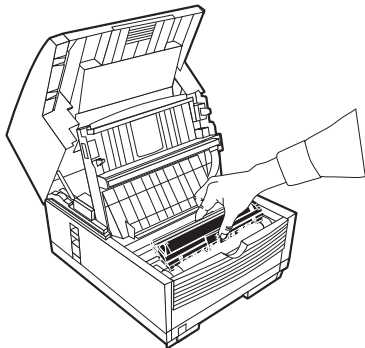

- 5 Put the image drum cartridge back into place.
- 6 Press down at each end of the image drum cartridge to make sure it is installed correctly.

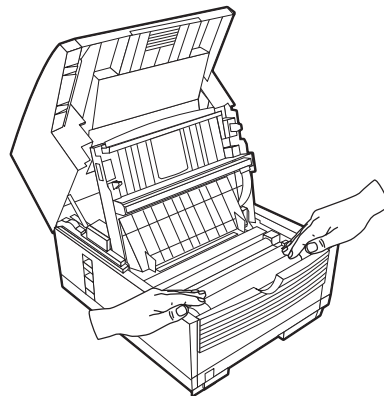

- 4 Grasp the protective sheet and pull it out.

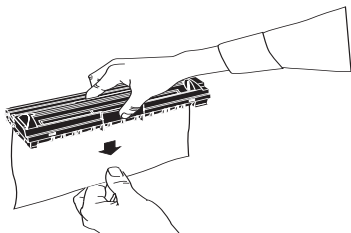

Installing the Toner Cartridge

- 1 Lift out the toner well cover and discard.

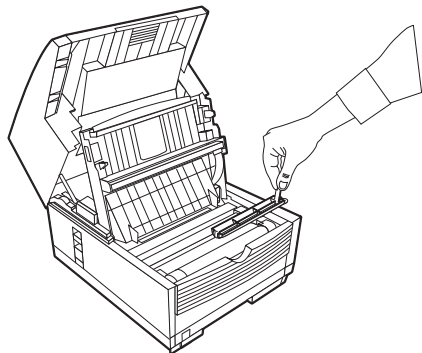

- ! **Warning:** *Be careful when handling the toner cartridge. Do not let toner spill onto your clothing or other porous materials. If you experience any problems with toner, see the Safety guides at the beginning of this section.*
- ! **Important:** *This machine will only operate using toner cartridges specified by Konica for this facsimile machine. The use of any other toner will result in the display of an operation error and in machine malfunction.*

- 2 Unwrap the toner cartridge and gently shake it to distribute the toner. Then carefully peel the tape from the bottom of the toner cartridge.

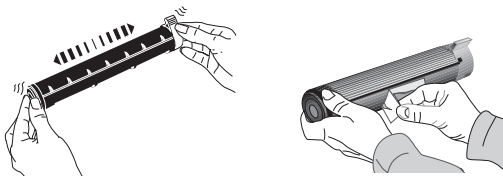

- 3 Holding the toner cartridge with the bottom down, insert the left side into the toner well, placing it under the tab (a).

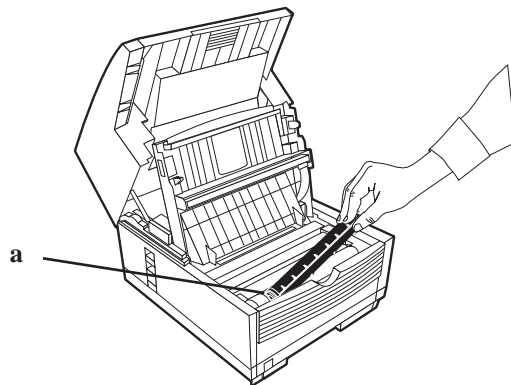

4 Lower the right side down into the toner well.

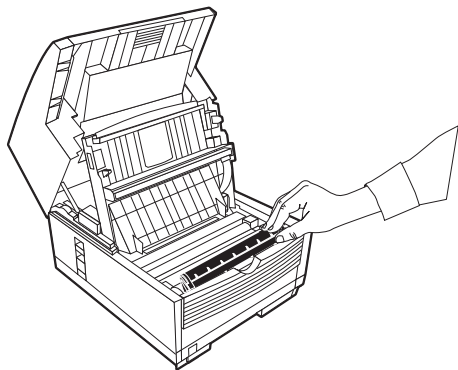

6 Close the copy stacker and document tray. Make sure the cover is firmly closed.

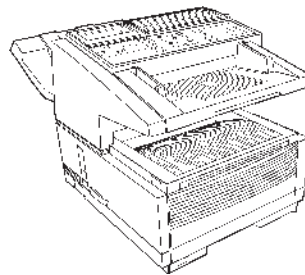

5 Push the lock lever (in the direction of the arrow) until it stops.

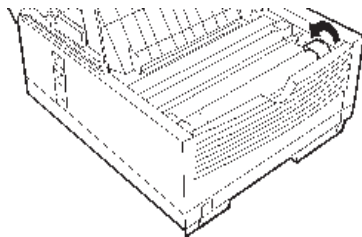

Attaching the Document Stacker

Attach the document exit stacker on the back of the machine using the latching mechanism provided.

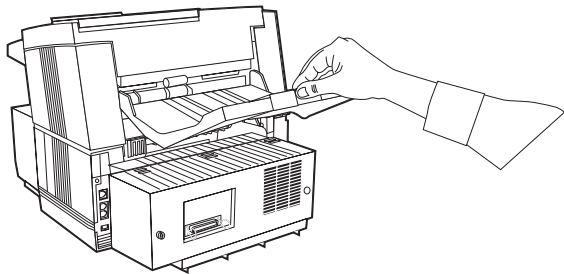

Connecting to the Telephone Line

1 Insert one end of the telephone cord into the LINE jack in the back of the machine.

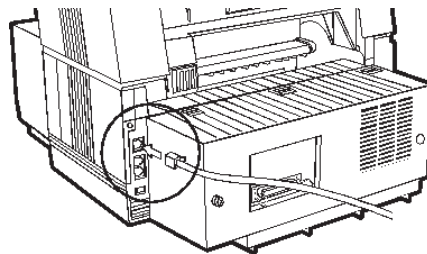

2 Insert the other end into your wall telephone jack.

Connecting Optional External Devices

Handset

If you purchased an external handset option with your fax machine, follow these instructions to install it.

- 1 Plug in one end of the handset cord into the handset and the other end into the jack on the front of the cradle. Place the handset in the cradle.
- 2 Insert the supplied telephone cord into the jack located on the back of the cradle.
- 3 Insert the end of the cord into the TEL jack on the back of the fax machine.

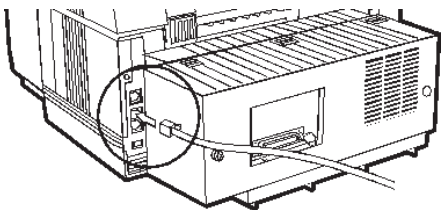

! *The two TEL jacks are provided to allow you to connect both an external handset and an answering machine.*

Telephone

! *Important: Any external telephone or answering machine connected to your fax machine must be FCC (US) or CSA (Canada) approved.*

- 1 Insert one end of the telephone cord into the TEL jack on the back of the fax machine.
- 2 Insert the other end into the jack in your external device.

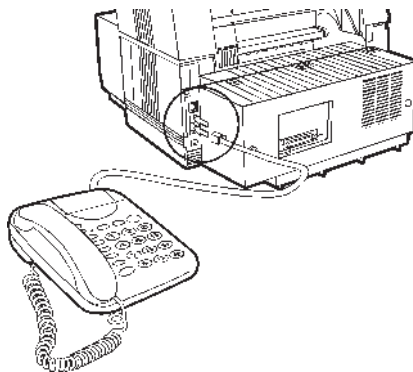

Answering Machine

Refer to “Connecting an External Telephone.”

- ! *You must have the TAD mode feature turned on for an answering machine to work with your fax machine. See “Setting Basic Features, Setting the Answering Mode.”*

Answering Machine and Telephone

- 1 Connect your answering machine to your fax machine.
- 2 Plug your external telephone’s cord into the telephone jack on your answering machine.

- ! *You must have the TAD mode feature turned on for an answering machine to work with your fax machine. See “Setting Basic Features, Setting the Answering Mode.”*

Connecting Power

- 1 Plug the power cord into the back of the unit.

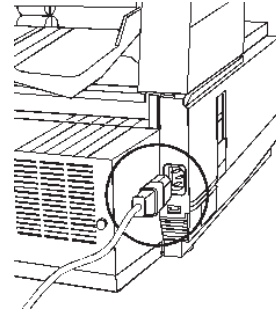

- 2 Plug the other end into a grounded AC power outlet.
- 3 Turn on the power switch.

Loading Paper

Your fax machine can hold up to 250 sheets of standard-weight (20 lb. [75 g/m²]) paper in letter, legal, and A4 sizes. For best results, use paper specially made for laser printers or photocopiers.

- ! **Load paper into the tray print side DOWN.**
- **If you are loading letterhead, place the paper print side down, with the letterhead near the handle part of the tray.**
- ! **If you are receiving a document created on legal-size paper, the document will be reduced to fit on letter size paper. The vertical length of the received page image is automatically reduced to fit on the paper loaded, down to 75% of the original length.**
- ! **Your fax machine is set at the factory to use letter size paper. To use a different paper size, change the 1ST PAPER SIZE user function setting to match your new paper size.**
See “Setting Basic Features, Other Basic Parameters, Paper-Size Setting.”

- 1 Pull out the paper tray.

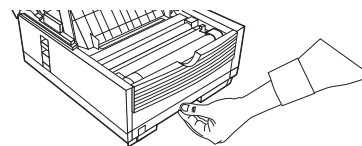

- 2 Adjust the paper guides (a) to the width of your paper. Set the left guide all the way to the left. Set the right guide to the marker for the size you're using.
- 3 Lift up the paper length adjustment guide (b) and set it to the length of your paper. If using legal size paper, rotate the extension (c) at the back of the tray.

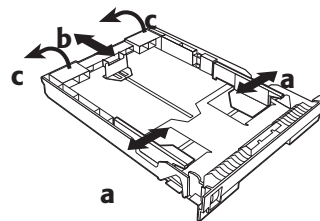

- 4 Remove the paper from its wrapper. *Note the “print side” notice printed on the label.* Fan the paper.
- 5 Load the paper into the paper tray, print side down.

Selecting Functions and Settings

The display (a) and navigating keys (b) on the control panel simplify setting your machine's functions.

Press **Menu/Exit** (c) to access the menu.

The machine functions are organized in a menu structure. Functions are shown in the display as you navigate through the menu, using the navigation keys. If a document is loaded, menu functions for sending documents are displayed first. If no document is loaded, other menu functions are displayed.

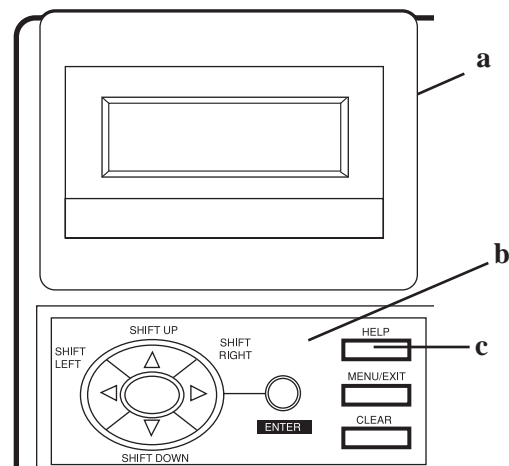

Navigating the Function Menu

The menu is set up in a multilevel structure of functions, options, and settings. A function can include a number of options and settings.

For example, **Polling TX/RX** includes 2 options—Polling TX and Polling RX. Each of these options includes a number of possible settings.

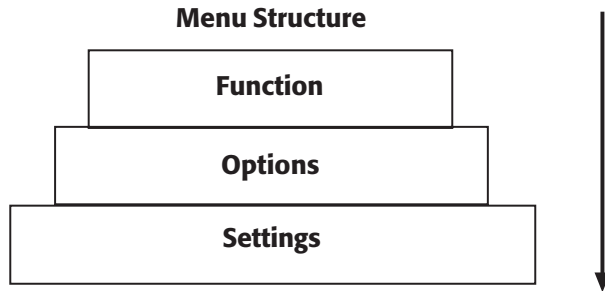

Primary Menu Functions

- Delayed TX
- Delayed Batch TX
- Priority TX
- Confidential TX
- Relay Initiate TX
- Polling TX/RX
- Print From Memory
- Report Print
- Location Program
- Setup
- Counter
- Printer Cleaning

Using the Help Key

To see how the menu is organized, press **HELP (1)**. Your machine prints Help and Function Lists, which provide instructions for accessing menu items. These are helpful when you are setting your machine's features.

See "Help and Helpful Hints."

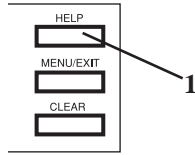

Setting Features

There are two ways to navigate through the functions:

Step Access

The step access method moves through the function menu step by step. It lets you see your choices at each level.

Speed Access

If you know exactly what settings you want to change, the speed access method takes you directly to most points on the menu. Speed access numbers are only assigned to Set Up menu functions.

Using Step Access

To navigate through the various functions step by step, use the navigation keys:

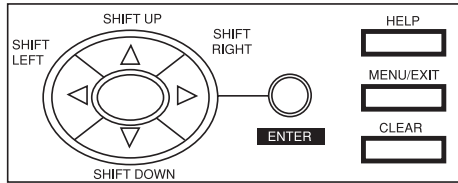

Press the **MENU/EXIT** key to activate the function menu mode and to exit the function menu mode and return to standby state.

Press **SHIFT UP** ▲ to move to the previous function or option

Press **SHIFT DOWN** ▼ to move to the next function or to move from the upper row to the lower row when data is entered in two rows.

Press **SHIFT LEFT** ◀ to move to the previous function or to move the cursor to the left.

Press **SHIFT RIGHT** ▶ to move the cursor to the right.

Press **ENTER** to set an option.

Press **CLEAR** to clear entered data.

Using Speed Access

If a function has a speed access number, type in the number at the menu display prompt to access the function.

Speed access numbers must be entered in two-digit format (for example, 00 or 99).

A list of speed access numbers follows this section.

Here is an example of using speed access.

To access the **Redial Tries** function, you only need to press three keys.

From the standby mode with no document loaded:

- 1 Press **Menu/Exit**.
- 2 Press **4** key.
- 3 Press **0** key.
- 4 **Redial Tries** function appears.
- 5 Enter the setting you want.

Speed Access Numbers

There are seven types of speed access numbers.

Clock Adjustment

ID/Password Programming

Machine Settings

Dial Options

Incoming Options

Report Options

LAN Options

The speed access numbers and their assigned functions are listed in the following sections.

Speed Access Numbers (by Type)

Clock Adjustment

00 Clock Adjustment

ID/Password Programming

01 TSI/CSI

02 Sender ID

03 Personal Box

04 Memory Password

Machine Settings

10 Auto Answer Mode

11 Monitor Volume

12 Buzzer Volume

13 User Language

14 Remote Diagnosis

15 TX Mode Default

16 No Toner Memory Receive

17 Memory Full Save

18 Instant Dial

19 Restrict Access

20 ECM Function

21 Closed Network

22 Toner Save

23 Sender ID Switch

24 1st Paper Size

25 2nd Paper Size

This is active only when the second paper tray is installed.

SpeedAccess Numbers (by Type)

Dial Options

- 40 Redial Tries
- 41 Redial Interval
- 42 Auto Start
- 43 Dial Tone Detect
- 44 Busy Tone Detect
- 45 MF/DP
- 46 Pulse Dial Rate *
- 47 Pulse Make Ratio *
- 48 Pulse Dial Type *
- 49 MF Tone Duration *
- 50 PBX Line
- 51 Flash/Earth/Normal *
- 52 Dial Prefix

** Settings for 46, 47, 48, 49, and 51 should only be changed by Authorized Service Technicians.*

Incoming Options

- 60 Incoming Ring
- 61 Remote Receive
- 62 T/F Timer Program
- 63 Continuous Tone
- 64 PC/FAX Switch
- 65 CNG Count
- 66 Ring Response
- 67 Distinctive Ring

Report Options

- 70 MCF (Single Loc.)
- 71 MCF (Multiple Loc.)
- 72 Message in MCF
- 73 Error Report (MCF)

SpeedAccess Numbers (by Type)

LAN Options

! *Functions 80 to 85 are reserved for future options.*

Setting Basic Features

Setting the Date and Time

Follow these instructions to set the date and time:

- 1 Press **Menu/Exit** to enter the menu.
- 2 Using the numeric keys (0-9), enter speed access number 00. The display shows:

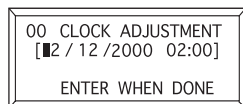

- 3 Enter the current date (xx/xx/xxxx) and time (hh:mm) using the numeric keys (0-9), press **Enter**.

! *If invalid data is entered, the Enter key will not operate.*

- 4 Press **Menu/Exit** to return to standby mode.

Setting the Language

- 1 Press **Menu/Exit** to enter the menu.
- 2 Using the numeric keys (0-9), enter speed access number 13.
- 3 Select the language you want to appear on the display panel.
- 4 Press **Menu/Exit** to return to standby mode.

Setting Your Fax Machine's ID

Fax machines must identify the sender (Sender ID) and the sender's telephone number (TSI/CSI) on each page of every fax sent.

- ! *Important: Programming this information into your fax machine is required by law in the United States.*

TSI/CSI

This is the telephone number of your fax machine. This number is printed at the top of the faxes you send, and appears on the displays and reports of other fax machines you are communicating with. A TSI/CSI can be up to 20 characters long.

Sender ID

This is a descriptive title that identifies the sender—usually the location of your fax machine or the name of your company or office. It is printed at the top of every fax you send. You can enter up to 32 characters. The first 16 characters will also be used as your Personal ID, which may appear on the displays or reports of other fax machines you are communicating with.

Setting the TSI/CSI and Sender ID

- 1 Press **Menu/Exit** to enter the menu.
- 2 Input speed access number 02.
- 3 Input up to 20 numbers and characters (0-9/Hyphen/Space/+), press **Enter**.
- 4 Press **Menu/Exit**.

Setting the Answering Mode

Procedure

- 1 Press **Menu/Exit** to enter the menu.
- 2 Input speed access no. 10 (Auto Answer)
- 3 Press ▼ or ▲ to select the desired mode, press **Enter**.
- 4 Press **Menu/Exit** to return to standby mode.

Set the answering mode based on how you want your machine to answer calls and what telephone equipment is connected to it.

Choose the mode that best fits your needs.

List of Modes

- Auto Receive Mode [FAX]
- Manual Receive Mode [TEL]
- Telephone/Fax Mode [T/F]
- Telephone Answering Device Mode [TAD]
- Memory Reception Mode [MEM]
- Forwarding Mode [FWD]
- PC Fax Mode [PC]

Auto Receive Mode [FAX]

Your machine is connected to a telephone line reserved only for fax communication.

This is the factory setting.

Your machine assumes all incoming calls are fax messages and automatically receives all incoming fax messages.

Manual Receive Mode [TEL]

You use the same line for both fax and telephone calls and the majority of your incoming calls are telephone calls.

To use this feature, you must have an external, optional handset or telephone connected to your fax machine.

When someone calls, your machine rings like a telephone. You can answer from an external telephone connected to your machine. If you pick up the hand set and hear fax machine tones, press the **Start** key to receive the fax. If you do not answer the phone and someone tries to send you a fax message, your machine will not accept it.

Telephone/Fax Mode [T/F]

Incoming calls are a mix of fax and telephone calls.

To use this feature, you must have an external, optional handset or telephone connected to your fax machine.

The display will show **Lift Handset**.

In this mode, your machine detects whether the incoming call is a fax or a voice call. When the call is from another fax machine, your machine switches to fax mode and receives the message. When the call is a voice call, your machine rings like a telephone. If you do not answer, it switches back to fax mode to allow the calling party to manually send a fax.

Telephone Answering Device Mode [TAD]

You have an external, optional answering machine connected to your fax machine.

In this mode, your machine detects whether an incoming call is a fax or voice call. If it is a fax call, your machine receives the fax. If it is a voice call, your machine rings, then your answering machine activates. If you set the Remote Receive user function, the caller can send a fax at any time during or after the recorded message by using their keypad to enter the remote receive number you have programmed. This number activates fax reception. Add something like this to your answering machine message: “To send a fax now, press XX [the programmed number.]”

See “Setting Basic Features, Dial and Incoming Call Parameter Settings, Incoming Call Parameters.”

Memory Reception Mode [MEM]

Received data is not printed but is stored into memory, even if there is fax paper on which to print.

Use the Print Operation function to print out data stored in memory during Memory Reception mode. You can set a password (USER PROGRAMMING under MEM. PASSWORD PRG) to disable the Memory Reception mode.

Forwarding Mode [FWD]

All fax communications are received into memory, then forwarded to another telephone number.

When set to this mode, the machine receives all fax communications into memory, and then automatically sends the messages to the telephone number programmed into the Call Forwarding function. This function displays only when a forwarding number has been programmed.

PC Fax Mode [PC]

! *This mode is available only if an optional MFP Kit is installed.*

Options vary according to the model of your machine. See “Options and Accessories.”

Incoming faxes are stored on you computer’s hard disk instead of printing immediately.

This mode is only available when the machine is connected to a personal computer via optional multifunction printer (MFP) software. When activated, the machine forwards the call directly to the computer. This lets you work with faxes on your computer using the software included with the MFP option.

Dial and Incoming Call Parameter Settings

These settings allow you to control the way your machine dials telephone numbers and receives incoming calls. Setting these functions before beginning use of your machine will make your fax communications more efficient.

Setting Dial and Incoming Call Parameters

- 1 Press **Menu/Exit** to enter the menu.
- 2 Input the speed access number for the dial or incoming call parameter you want to change.
- 3 Use **▼** or **▲** to select the desired setting. Press **Enter**.
- 4 Press **Menu/Exit** to return to standby mode.

Dial Parameter Settings

Redial Tries

Speed access no. 40.

This function controls how many times your machine automatically redials a number that is busy or does not answer.

Available settings are from 0 to 10 tries.

3 tries is the default setting.

Redial Interval

Speed access no. 41.

The function controls how long your machine waits between each automatic redial attempt.

Available settings are from 1 to 6 minutes.

The default setting is **3 minutes** between dialing attempts.

Auto Start

Speed Access no. 42.

With this function set to **ON**, the machine automatically begins dialing as soon as a location is selected by pressing a One-Touch key or by entering another Speed Dial number.

There is no need to press the Start key.

Available settings are **ON** and OFF.

ON is the default setting.

Dial Tone Detect

Speed access no. 43

This function allows your machine to wait for and detect a dial tone before dialing. Set to **ON**, a dial tone must be detected.

Available settings are **ON** and OFF.

ON is the default setting.

Busy Tone Detect

Speed access no. 44

This function allows your machine to detect a busy tone when sending a fax.

Available settings are *ON* and OFF.

ON is the default setting.

Tone/Pulse (MF/DP)

Speed access no. 45

This function controls which method your machine uses for dialing.

DP: dial pulse dialing, which uses monotone pulses to dial a number like a rotary telephone,

MF: multi-frequency dialing (touch tone), which uses different tones to dial a number.

MF is the default setting.

Tone (MF) Duration

Speed access no.49

If the machine is set to the MF dialing method, this function controls the duration of the tones used for dialing.

Tone duration varies by country.

Available settings are 75, 85, and *100* ms.

100 ms is the default setting.

PBX LINE

Speed access no. 50

This function must be ON if your machine is connected to a PBX. Once this function has been turned on and the access digit function has been programmed, your machine recognizes the access digit you use in your PBX to get an outside line.

Available settings are on and *OFF*.

OFF is the default setting.

To change this setting, see “Setting Basic Features, Connecting to a PBX.”

FLASH/EARTH/NORMAL

Speed access no. 51

This function sets the type of PBX line your machine is connected to (if your machine is connected to a PBX).

Available settings are **NORMAL** (N), flash (F) and earth (E).

NORMAL (N) is the default setting.

DIAL PREFIX

Speed access no. 52

If your machine is connected to a PBX, use this function to tell your machine what access number is used to obtain an outside line from your PBX. You can enter up to 4 digits.

Available settings are ON and **OFF**.

OFF is the default setting.

To change this setting, see “Setting Basic Features, Connecting to a PBX.”

Incoming Call Parameters

Incoming Ring

Speed access no. 60

This function offers a soft ringing sound through the machine's built-in speaker when a call is received.

If the function is set to **OFF**, the machine does not emit a ringing sound during incoming calls.

If the function is set to **ON**, the machine emits a ringing sound when the machine is set to **TEL** (manual receive mode) or **Ring Response** is set to 20 sec (except 1 ring). When set to **DRC**, the machine emits a ringing sound for each incoming call with the same tone even if the **Distinctive Ring** parameter is set to **ON**.

Available settings are **ON**, **OFF** and **DRC**.

ON is the default setting.

Remote Receive

Speed access no. 61

This function allows switching from telephone to fax mode to receive an incoming fax. Use the keypad on the optional handset or external telephone to enter the remote receive number programmed into the machine.

Available settings are: **OFF**, 00, 11, 22, 33, 44, 55, 66, 77, 88, 99, ** or ##.

OFF is the default setting.

Continuous Tone

Speed Access no. 63

When this function is set to ON, a completion tone is emitted at the end of receiving a fax. Pressing the **Stop** key turns off the tone.

Available settings are ON and **OFF**.

OFF is the default setting.

PC/FAX Switch

Speed Access no. 64

When set to ON, the machine automatically switches to FAX when fax reception by a connected personal computer is not possible. Fax reception is disabled when the PC/FAX switch is set to OFF.

Available settings are **ON** and OFF.

ON is the default setting.

- ! *This parameter is available only if an optional MFP Kit is installed.*
- *Options vary according to the model of your machine. See “Options and Accessories.”*

Other Basic Parameters

Monitor Volume

Speed Access no. 11

The machine is equipped with a speaker for monitoring operations. This function provides a 5-level audio adjustment of the speaker.

Available settings are OFF, Low, *Mid*, High-Mid, High.

Mid is the default setting.

Buzzer Volume

Speed Access no. 12

The machine is equipped with a buzzer that sounds when a fax communication ends or, if an external telephone is connected, when the receiver is not properly returned to its cradle after use.

Available settings are Low, *Middle* and High.

Middle is the default setting.

User Language

Speed Access no. 13

Your machine has two languages installed—*English* and Spanish or French, depending on where you purchased it. The language programmed is used to display messages on the control panel as well as to print reports.

Available settings are *English*, Spanish, or French.

English is the default setting.

Paper-Size Setting

The machine can support two different paper settings (when the 2nd-Tray option is installed).

1'ST Paper Size

Speed Access no. 24

Sets the size of the paper loaded in the standard (built-in) paper tray. Default setting is **Letter**.

2'ND Paper Size*

Speed Access no. 25

Sets the size of the paper loaded in the second (optional) paper tray. Default setting is **Letter**.

** This setting is only available when the second tray is installed.*

Connecting to a PBX

Private Branch Exchanges (PBXs) are private telephone systems used to route calls internally (for example, in a company). When dialing a telephone number, if a prefix (access) number is required to open an outside line, the line is connected to a PBX. If your machine is connected to a PBX, please make the following changes to enable the machine to recognize the prefix digits in the telephone numbers used to obtain access to the outside line. After dialing the prefix digits, the machine waits until the outside line is available before dialing the rest of the number.

- ! *Service assistance may be required to make changes in some countries.*
- Some PBX systems may require additional adjustments to the machine.*
- If there are any problems with fax communications after changing parameters, please contact the nearest dealership for assistance.*

Entering a PBX Dial Prefix

- 1 Press **Menu/Exit** to enter Menu.
- 2 Input speed access no. 50 (PBX Line), wait.
- 3 Press **▲** or **▼** to select ON or OFF setting, press **Enter**.
- 4 Press **▼** until you reach Dial Prefix, press **Enter***.
- 5 Input the digit(s) normally dialed to obtain an outside line from the PBX, press **Enter**.
- 6 Press **Menu/Exit** to return to standby mode.

* Dial Prefix can also be accessed from the main menu by entering its speed access code 52.

- ! *Remember that all outside telephone numbers programmed into the machine must begin with the dial prefix of the PBX.*

Clearing the PBX Dial Prefix

- 1 Press **Menu/Exit** to enter Menu.
- 2 Input speed access no. 50 (PBX Line), wait.
- 3 Press **▲** or **▼** to select OFF setting, press **Enter**.
- 4 Press **Menu/Exit** to return to standby mode.

Programming Speed Dial Numbers

You can program (save) frequently dialed numbers into your machine. This way, you enter the full number once, and access the number with one or a few keystrokes thereafter.

230 spaces are available for programming numbers.

These spaces have four different types.

- One-Touch Speed Dial
- 2 Digit Speed Dial
- 3 Digit Speed Dial
- Group Dial

! *Each fax number that you enter or program into your machine can be up to 40 digits long. If you need to dial a number with more digits, use the chain dial feature. For more information on chain dialing, refer to “Programming Speed Dial Numbers, Chain Dialing.”*

Types of Speed Dial Numbers

One-Touch Speed Dial Numbers are spaces 01 to 80.

They are called one-touch because you access them with one touch of a button.

2 Digit Speed Dial Numbers are spaces 81 to 99.

They are called two-digit because you access them by entering their two-digit space designation (81 to 99).

3 Digit Speed Dial Numbers are spaces 100 to 230.

They are called three-digit because you access them by entering their three-digit space designation (100 to 230).

Group Dial Number

Speed dial numbers can be grouped together so you can quickly fax a document to multiple locations with one key touch.

For more information on group faxing, refer to “Sending a Fax to Multiple Locations, Group Faxing.”

One-Touch Speed Dials

For quick and easy faxing operations, you can store up to 80 telephone numbers in the machine's memory and send documents to a fax number by pressing a single key.

1	2	3	4	5	6	7	8	9	10
Q	W	E	R	T	Y	U	I	O	P
11	12	13	14	15	16	17	18	19	20 UNIQUE
A	S	D	F	G	H	J	K	L	
21	22	23	24	25	26	27	28	29	30
Z	X	C	V	B	N	M	.	:	DEL
31	32	33	34	35	36	37	38	39	40
CALL	@	-	/	SPACE	'	-	+	PAUSE	

Your fax machine is equipped with 80 one-touch keys.

The first 40 are accessed directly from the “top” of the control panel. The second 40 are accessed by lifting the panel to reach the “bottom” of the control panel. Two 40-digit numbers can be programmed to each one-touch key, a primary number and an alternative number that is used if the primary number is busy or goes unanswered. You can also enter a 15 character location ID (name) for each key.

- ! *The One Touch Sheet(s) provide space for Speed Dial numbers 1 through 80. For Speed Dials 81 and above, program the number(s) and print the Telephone Directory. See “Reports, Telephone Directory.”*

2 or 3 Digit Speed Dials

In addition to one-touch speed faxing, you can program an additional 150 numbers for 2 or 3 digit entry faxing.

2 Digit Speed Dial Numbers are spaces 81 to 99.

They are called two-digit because you access them by entering their two-digit space designation (81 to 99).

3 Digit Speed Dial Numbers are spaces 100 to 230.

They are called three-digit because you access them by entering their three-digit space designation (100 to 230).

Group Faxing

Speed dial numbers can be grouped together so you can quickly fax a document to multiple locations with one key touch.

For more information on group faxing, refer to “Sending a Fax to Multiple Locations, Group Faxing.”

Programming One-Touch and 2 or 3 Digit Speed Dial Numbers

To program your speed dial numbers, follow these instructions.

Programming speed dial numbers has two steps.

- collecting the information
- programming the information

Collect Information

Gather the following information for each Speed Dial number you want to store:

- Name
- Primary Telephone Number (LOC#)
- Alternate Telephone Number (ALT#)
- Communications Speed
- Echo Protection State

Name

Use letters, numbers, and symbols, in any combination, for the name.

The name can be up to 15 characters long.

Primary Telephone Number (LOC#)

This is the main number.

The main number can be up to 40 characters long.

Alternate Telephone Number (ALT#)

If the main number is busy or does not answer, the machine automatically dials this alternate number.

The alternate number can be up to 40 characters long.

Communications Speed

The available settings are **33.6 K**, 28.8 K, 14.4 K, 9.6 K, and 4.8 K.

The default setting is **33.6 K**.

If the machine you are communicating with is an older fax machine, and you are having problems communicating with it, try adjusting the speed to a lower setting.

Echo Protection State

The available settings are ON or **OFF**.

The default setting is **OFF**.

If you are experiencing problems communicating with a remote location in a very noisy telephone area, or with an overseas location, set Echo Protection to ON for the one-touch key assigned to that location.

Program the Information

To enter the information for each speed dial number, use one of the following input methods.

- Other Keys
- Numeric Keypad
- One-Touch Keypad

Other Keys

These keys are used in the programming process.

They include Menu/Exit, Shift keys, Enter, and Capital (CAPS).

Numeric Keypad

0-9/*/#: Use these keys to enter alphabetic characters (uppercase, lowercase).

Unique Key: Use this key to enter a variety of unique characters.

Symbols: ! # & ' () * + , - . / : ; = ? ·

Internet characters: @ “ (space) % ^

The ^ functions as a tilde symbol.

Symbols: ! # & ' () * + , - . / : ; = ? ·

Umlaut characters: Ä ß Ñ Ö Ü

Norwegian characters: Æ Å Ø æ å ø

Hyphen Key: Use this key as the “-” character when programming ID, PBX, public line, or international numbers

Clear Key: use this key to cancel ID, telephone number and programming entries.

One-Touch Keypad

The One-Touch keypad is arranged like a standard keyboard for quick touch typing of names, Sender and Location ID.

Alphabet Keys: (#1-27, except #20) Use these keys for easy entering of alphabetic characters.

Caps Key (One-Touch key #31): Use this key to switch between uppercase and lowercase when entering alphanumeric characters.

Unique Key (One Touch key #20): Use the same as the “0” of the numeric keypad. Also used to enter:

Symbols: ! # & ‘ () * + , - . / : ; = ? ·

Internet characters: @ “ (space) % ^

The ^ functions as a tilde symbol.

Symbols: ! # & ‘ () * + , - . / : ; = ? ·

Umlaut characters: Ä ß Ñ Ö Ü

Norwegian characters: Æ Å Ø æ å ø

Pause Key (One-Touch key #40): Use this key to enter automatic 3 second pauses in dialing. For example, use this key to tell the machine to wait for an outside or international line to open. Pauses in a telephone number dialing sequence are indicated by a “P.”

Space Key (One Touch key #36): Use this key to enter spaces when programming. Unlike the Pause key, spaces provide easier reading only and have no effect on dialing.

Del Key: (One-Touch key #30): Use this key to delete characters at the position of the cursor in the display panel when entering, ID, telephone numbers or programming functions.

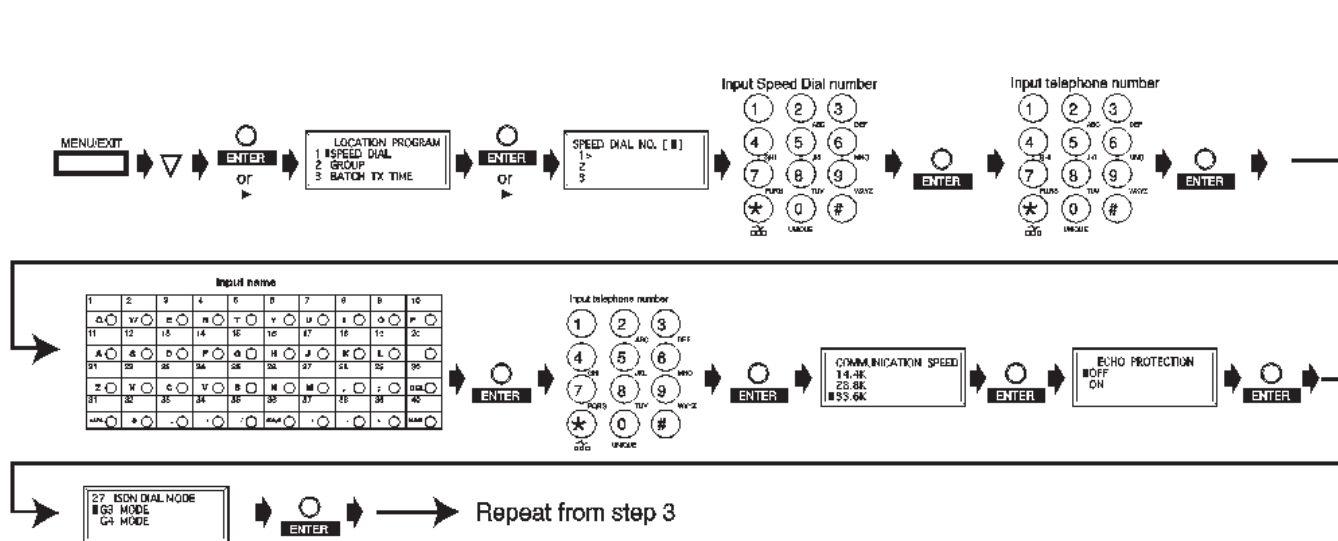

Programming a Speed Dial

- ! *Print the Telephone Directory before you begin programming. This provides a reference of the speed dial numbers already programmed.*

See “Reports, Telephone Directory.”

Be sure to write the name for any Speed Dial numbers you program on the One Touch Sheet(s).

The One Touch Sheet(s) provide space for Speed Dial numbers 1 through 80. For Speed Dials 81 and above, program the number(s) and print the Telephone Directory. See “Reports, Telephone Directory.”

- 1 Press **Menu/Exit** to enter the menu.
- 2 Press **▼** to select **Location Program**, press **Enter**.
- 3 The cursor will be at **Speed Dial**. Press **Enter**.
- 4 Input the speed dial number you want to program, then press **Enter**.

One-Touch Speed Dial Numbers are spaces 01 to 80.

They are called one-touch because you access them with one touch of a button.

2 Digit Speed Dial Numbers are spaces 81 to 99.

They are called two-digit because you access them by entering their two-digit space designation (81 to 99).

3 Digit Speed Dial Numbers are spaces 100 to 230.

They are called three-digit because you access them by entering their three-digit space designation (100 to 230).

- 5 Input the telephone number (LOC #), press **Enter**.
- 6 Input a name if desired (up to 15 characters), press **Enter**.
- 7 Input alternate telephone number (ALT#) if desired, press **Enter**.
- 8 Select **Communication Speed**, press **Enter**.
- 9 Select On or Off for **Echo Protection**, press **Enter**.
- 10 Repeat the above process from Step 3 until you have finished programming.
- 11 Press **Menu/Exit** to return the machine to standby mode.
- 12 When finished with the programming of One Touch keys, lift off the plastic cover. Use a pencil to write the name of the One Touch key you have programmed.

! • *Print the Telephone Directory when you finish programming. This provides a reference of the speed dial numbers already programmed.*

See “Reports, Telephone Directory.”

Be sure to write the name for any Speed Dial numbers you program on the One Touch Sheet(s).

The One Touch Sheet(s) provide space for Speed Dial numbers 1 through 80. For Speed Dials 81 and above, program the number(s) and print the Telephone Directory. See “Reports, Telephone Directory.”

Clearing a Speed Dial

- ! *Print the Telephone Directory before you begin clearing. See “Reports, Telephone Directory.” This provides a reference of the speed dial numbers already programmed.*

There are three ways to clear a speed dial number.

- Programming new information as a replacement to the existing speed dial information.
- Using DEL to erase the existing speed dial information.
- Using Clear

To program new information, refer to “Programming Speed Dial Numbers.”

To use DEL, refer to “Programming Speed Dial Numbers.”
When the existing number is displayed, use DEL key to erase the information.

Using Clear

- 1 Press **Menu/Exit** to enter the menu.
- 2 Press ▼ to select **Location Program**, press **Enter**.
- 3 The cursor will be at **Speed Dial**. Press **Enter**.
- 4 Select the speed dial number to be deleted (One Touch, 2-digit, 3-digit).
- 5 Press **Clear**.
- 6 Press **Enter**.
- 7 Press **Menu/Exit** to return the machine to standby mode.

Chain Dialing

Each fax number that you enter or program into your machine can be up to 40 digits long. If you need to dial a number with more digits, use the chain dial feature.

Creating a Chain Dial Number

- ! *Print the Phone Directory before you begin programming. See “Reports, Telephone Directory.” This provides a reference of the speed dial numbers already programmed.*

- 1 Program the first 39 digits into a Speed Dial number.
See “Programming Speed Dial Numbers, Programming a Speed Dial.”
- 2 Press the Plus (+) key (One-Touch key #39).
- 3 Program the rest of the number into a different Speed Dial number.

Dialing the Chain Dial Number

- 1 Load the document to be faxed.
SELECT LOCATION displays.
- 2 Select the first Speed Dial Number programmed.
- 3 Wait until **SELECT LOCATION** displays.
- 4 When prompted, enter the second Speed Dial number.
- 5 Press the Start key to begin sending the fax.

- ! *The remaining part of the number not programmed in the first Speed Dial number can also be input manually when prompted, using the numeric keypad (step 2).*

Programming a Group

If you often send a fax to many fixed locations, setting up these locations as a group will save time.

See “Sending a Fax to Multiple Locations.”

Basic Faxing

Document Guidelines

General

- Try to use good quality documents for your fax transmission. Documents that work best are typed or written with a black felt-tip pen on white (or light) paper.
- Do not send documents that are not rectangular.
- Never use documents that have wet or sticky surfaces, wrinkles, staples, or paper clips.
- Your machine can transmit documents with normal wear (staple holes, letter folds and minor corner folds).
- If you are not sure how a document will fax, first make a copy on your machine. Load the document (face down) and press the Copy.
- If your documents are heavily bent, creased or torn, make a copy on a photocopier and send the copy instead.

Single Page Specifications

Also see “Basic Faxing, Document Guidelines, General.”

Width

Minimum 5.8 inches (148 millimeters)

Maximum 8.5 inches (216 millimeters)

Length

Minimum: 5 inches (128 millimeters)

Maximum: 14 inches (356 millimeters)

Paper Weight

Minimum 13 pounds (50 g/m²)

Maximum 28 pounds (105 g/m²)

Paper Thickness

Minimum 0.002 inches (0.06 millimeters)

Maximum 0.006 inches (0.15 millimeters)

Multiple Page Specifications

Also see “Basic Faxing, Document Guidelines, General.”

For very heavy paper, load and send pages individually.

Width

Minimum 5.8 inches (148 millimeters)

Maximum 8.5 inches (216 millimeters)

Length

Minimum: 5 inches (128 millimeters)

Maximum: 14 inches (356 millimeters)

Paper Weight

Minimum 13 pounds (50 g/m²)

Maximum 28 pounds (105 g/m²)

Paper Thickness

Minimum 0.003 inches (0.08 millimeters)

Maximum 0.005 inches (0.13 millimeters)

Capacity

50 sheets of standard paper, 20 pound (80 g/m²)

Loading Documents

To prevent paper jams and problems during operation:

- Stack your documents neatly
- Align document edges before loading
- Don't load different size documents at the same time

! *You can load and prepare to transmit a document while your machine is still sending or receiving another message (as long as the document feeder is clear).*

This is called Dual Access.

To do this, load the document, select your location and press the Start key. Your document will be sent when the current communication ends.

- 1 Adjust the document guides (1) to the width of the paper you are using.

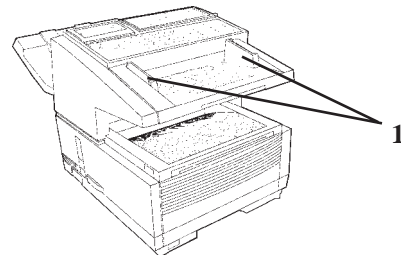

- 2 Neatly stack your documents, then insert them face down into the document feeder. Adjust the document guides for a snug fit.

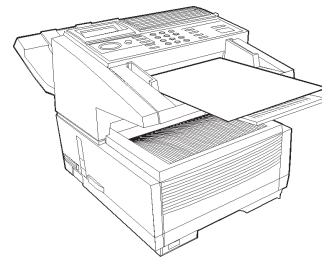

- 3 The machine grips the documents, and pulls in the bottom page.
- 4 If necessary, use the Resolution and Type of Original keys for the best possible quality.

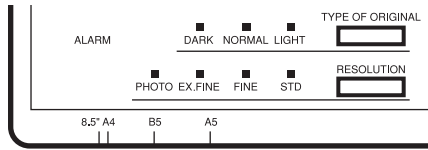

- 5 Your documents are now ready for faxing or copying.

Resolution

- For normal office documents, use STD (standard) resolution (default)
- For documents with small type or other fine details, use FINE or EX.FINE resolution.
- For documents with photos or many shades of gray, use PHOTO resolution.

Contrast

- For documents with normal contrast (default setting), use NORMAL contrast.
- For documents that are too light, use LIGHT contrast.
- For documents that are too dark, use DARK contrast.

Sending a Fax

You may send a fax to a single location or to multiple locations.

This section describes faxing to a single location.

There are two ways to send one fax to multiple locations using one fax session: group fax or broadcast fax. See “Sending a Fax to Multiple Locations.”

Procedure

- 1 Load your documents.
- 2 Select the entry method, referring to the instructions in the following sections.

Entry methods are:

- One Touch
- 2 or 3 Digit Speed Dial
- Search
- Numeric Keypad
- External Telephone

Using a One Touch Speed Dial Key

Press the One-Touch key you have programmed.

1	2	3	4	5	6	7	8	9	10
Q	W	R	P	T	Y	U	I	O	P
11	12	13	14	15	16	17	18	19	20
A	B	D	F	G	H	J	K	L	
21	22	23	24	25	26	27	28	29	30
Z	X	C	V	B	N	M	,	.	DEL
31	32	33	34	35	36	37	38	39	40
NAME	*	-	:	/	NAME	\	-	-	NAME

Using 2 or 3-digit Speed Dial

- 1 Press the **Speed Dial/Search** key.
- 2 Enter the Speed Dial number (2 or 3-digit) using the numeric keypad.
- 3 Press the **Enter** Key. Wait.
- 4 The document will begin faxing.

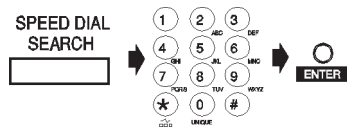

Using the Search Function

- 1 Press the **Speed Dial/Search** key. The display will show ENTER 1'ST CHAR.
- 2 Using the One-Touch key, enter the first letter of the name of the location you want to transmit to.
- 3 Repeatedly press ▼ to scroll through the list of location IDs beginning with the selected letter.
- 4 When the correct location is found, press the **Start** key to begin faxing.

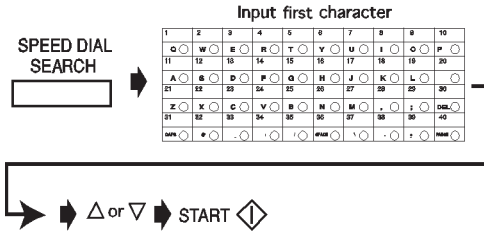

Using the Numeric Keypad

- 1 Dial as you would on a normal telephone.
- 2 If you make a mistake, press the DEL key to back up one space, then enter the correct number.
- 3 Press the **Start** key.



Using An External Telephone

To use this feature, you must have an external, optional handset or telephone connected to your fax machine.

- 1 Pick up the receiver and dial the number. If the receiving machine is in automatic reception mode, a high-pitched tone will be heard.
- 2 If someone answers, request that they press the **Start** key on their machine.
- 3 You (the sender) will also need to press the **Start** key on your machine.

Rejecting Unsolicited Fax Messages

Closed Network

Speed Access 21

If closed network is on, your machine will **ONLY** accept faxes from numbers programmed as Speed Dial Numbers.

This keeps out unwanted faxes (such as advertising).

You can also set your machine to send faxes to **ONLY** the numbers programmed as Speed Dial Numbers.

The Closed Network settings are:

- Limited reception (RX)
- Limited transmission and reception (TX/RX)
- No limitations (**OFF**). This is the default setting.

- ! *If Closed Network is set to TX/RX or RX, your machine will **ONLY** accept faxes from numbers programmed as Speed Dial Numbers.*

*Any numbers **NOT** programmed as Speed Dials will be rejected by the fax machine.*

Setting a Closed Network

- 1 Press **Menu/Exit** to enter the menu.
- 2 Input speed access number 21 (Closed Network); wait.
- 3 When **Closed Network** displays, press ▼ or ▲ to select a setting, press **Enter**.
- 4 Press **Menu/Exit** to return to standby mode.

Power Failures

A battery in your fax machine prevents the loss of data stored in memory at the time of a power outage.

Typical memory-backup time with a fully charged battery is 72 hours.

If data is in memory when power is restored, the machine continues operations from the point when power was lost.

If the data in memory is lost when power is restored, the Power Outage Report prints.

Power Outage Report

Use this report to determine which received messages you may have lost, and which transmissions you may have to resend.

For more information, refer to “Basic Faxing, Receiving Messages to Memory.”

Display Messages

Here are some of the messages you may see during a typical fax transmission.

(location)

The remote location's Personal ID, TSI/CSI, Location ID or the telephone number you entered will identify the location during transmission.

CALLING

The line is ringing.

SENDING

The machine is transmitting a fax.

RESULT – OK

The fax was sent successfully.

COMMUN. ERROR

If you see this or another error message, a problem occurred during the communication. Try resending the fax. For more information, see "Problem Solving."

Basic Faxing Situations

Real-Time Dialing

Occasionally you may want to dial numbers in real time, one digit at a time. Press the **Hook** key on your control panel to open a telephone line, you will hear a dial tone. Enter the number. If an external telephone is connected to your machine, you can dial in real time by picking up the handset.

Redialing

If a line is busy, or there is no answer, the machine waits and then automatically redials the number. Also, if the machine is transmitting from memory and a communication error occurs, it automatically redials the number and sends the fax again. You can redial a number at any time by pressing the **Redial** key.

Confirming Results

After transmission, press the **Enter** key once (with no documents loaded). A message displays on the control panel, confirming your transmission.

To print the Message Confirmation Report (MCF), press the **Enter** key a second time.

See “Reports, Message Confirmation Report.”

Stopping a Transmission

To stop a transmission while it is in progress:

- 1 Press the **Stop** key twice.

The display shows **STOPPED**.

- 2 If documents are stuck partway through the document feeder, you may see a **RELOAD DOCUMENT** message on the display. Press the **Stop** key again. The machine feeds the document the rest of the way through the document feeder.

Receiving Faxes Manually

If your machine is set to the manual receive (TEL) mode, follow the instructions below to receive faxes. You need to have an optional handset installed, or an external handset connected.

- 1 When your telephone or fax machine rings, pick up the handset. If a person is on the line, carry on your conversation.
- 2 If a signal from a remote fax machine is heard, or if a person wishes to fax you a document after a conversation, press the **Start** key.
- 3 When the **RECEIVING** message appears on the display, hang up the handset. The machine will emit a tone following disconnection, telling you that the transmission was successful.

No Paper Reception

If your machine runs out of paper:

- A **NO PAPER, REPLACE PAPER** message appears on the display.
- The machine continues to receive faxes in memory.
- Any messages received in memory are printed when the paper is replaced.

For more information, see “Basic Faxing, Receiving Messages to Memory.”

No Toner Reception

When your machine is running low on toner it displays **TONER LOW, REPLACE TONER CART.**

- If user function 16:NO TONER MEM.RX is set to OFF (default setting), and the print quality is still legible, you can continue to use the toner cartridge without replacing it. When until the print quality is not legible, replace the toner.
- If User Function 16:NO TONER MEM RX is set to ON, your machine automatically receives and stores messages in its memory when toner is low. The message **MSG. IN MEMORY** appears on the display.

For more information, see “Basic Faxing, Receiving Messages to Memory.”

Receiving Faxes to Memory

When your machine is set to Memory Reception Mode (MEM), it receives data into memory without printing and displays **MSG. IN MEMORY**.

See “Setting Basic Features, Setting the Answering Mode, Memory Reception Mode.”

You may want to set your machine for memory reception if you receive faxes containing confidential information.

When Are Faxes Received to Memory?

Your machine receives messages into memory if:

- you set (program) the machine to receive messages to memory
- the machine runs out of paper
- the machine runs out of toner

When Are Memory Messages Printed?

When messages are received into memory, they will print when

- paper is replaced, if the machine ran out of paper
- you request them, if the machine is set to receive messages to memory
- when the machine is switched from Memory Reception Mode to Auto Receive Mode

Memory Message Limitations

The amount of memory installed in your machine will determine how many messages may be stored.

You always know how much memory is available to you.

The amount of available memory is shown on the display panel. This amount will vary, depending on what has already been entered into memory.

A battery in your fax machine prevents the loss of data stored in memory at the time of a power outage.

Typical memory-backup time with a fully charged battery is 72 hours.

If data is in memory when power is restored, the machine continues operations from the point when power was lost.

If the data in memory is lost when power is restored, the Power Outage Report prints.

Active Memory Files Report

This report provides a list of all messages stored in your machine's memory, including documents waiting for transmission and documents which have been received and not yet printed. Information provided on this report includes:

- The date and time at which the message was scanned into memory for transmission.
- The name or telephone number of the machine you were communicating with
- The communication mode used for each transmission or reception.
- The number of pages.
- The result.

Printing the Active Memory Files Report

- 1 Press **Menu/Exit** to enter the menu.
- 2 Press **▲** to select **Report Print**, press **Enter**.
- 3 Press **▼** or **▲** until the report you want appears on the display. Press **Enter**.
- 4 Print all the reports you want, then press **Menu/Exit** to return to standby mode.

Printing Messages Stored in Memory

- 1 Press **Menu/Exit** to enter Menu.
- 2 Press ▼ to select **Print from Memory**, press **Enter**.
- 3 Press ▼ to select **Print Memory Msg.**, press **Enter**.

! *If a memory reception password has been set, enter the*
● *4-digit password. Press Enter.*

- 4 All data in memory is printed.

! *If you switch to Auto Receive Mode, disabling Memory*
● *Reception Mode, all messages stored in memory are*
printed out.

Canceling Messages Stored in Memory

Erasing Messages Received in Memory Without Printing Them

- 1 Press **Menu/Exit** to enter Menu.
- 2 Press ▼ to select **Print from Memory**, press **Enter**.
- 3 Press ▼ to select **Print Memory Msg.**, press **Enter**.
- 4 **MSG. IN MEMORY, PRINTING** displays.
- 5 To erase the message instead of printing it, press the **Stop** key.
- 6 The display shows **PRINT MEMORY MSG. MEMORY CANCEL?**
- 7 Press the ◀ to erase the message from your machine's memory.
- 8 Press **Enter** when done.

Messages in Memory and Power Losses

A battery in your fax machine prevents the loss of data stored in memory at the time of a power outage.

Typical memory-backup time with a fully charged battery is 72 hours.

If data is in memory when power is restored, the machine continues operations from the point when power was lost.

If the data in memory is lost when power is restored, the Power Outage Report prints.

Power Outage Report

Use this report to determine which received messages you may have lost, and which transmissions you may have to resend.

Dual Access

Your fax machine's dual access feature allows you to load and prepare to transmit a document while it is receiving or sending another fax from memory. This feature increases your productivity and reduces the time you spend waiting for other operations to finish.

Dual Access applies

- while making a copy
- while sending a fax
- while receiving a fax

What You Can Do While Making Copies

While your fax machine is making copies, you can:

- 1 Continue to receive faxes while copies are printing, if your machine is set to receive faxes into memory.

What You Can Do While Sending a Fax

After your fax machine has finished scanning a document into memory and while it is transmitting from memory, you can:

- 1 Make copies.
- 2 Load another document and prepare it for transmission. You can continue to load documents as long as memory is available in your machine. When the first transmission is complete, the next fax is automatically sent.
- 3 Enter the fax number before loading a document.

Why is this important?

Documents are placed **FACE DOWN** on the feeder of your machine.

If the only record of the fax number you are dialing is printed on the document being sent, it can be difficult to remember the number. Entering the number *before* loading the document allows you to see the number when keying. Once the number is entered, place the document (face down) on the feeder.

! For situations 2 and 3, TX Prep Activated *displays for 2-3 seconds. Do not attempt to load documents during this short time!*

What You Can Do While Receiving a Fax

While your machine is receiving a fax, you can:

- 1 Load another document and prepare it for transmission. You can continue to load documents as long as memory is available. When the first transmission is complete, the next fax you have loaded is automatically sent.
- 2 Continue to receive faxes while earlier received messages are printing, if your machine is set to receive faxes into memory.
- 3 Enter the fax number before loading a document.

Why is this important?

Documents are placed **FACE DOWN** on the feeder of your machine.

If the only record of the fax number you are dialing is printed on the document being sent, it can be difficult to remember the number. Entering the number *before* loading the document allows you to see the number when keying. Once the number is entered, place the document (face down) on the feeder.

- ! *For situations 1 and 3, TX Prep Activated displays for 2-3 seconds. Do not attempt to load documents during this short time!*

Making Copies

Your machine can be used as a convenience copy machine.

It can product up to 99 copies at one time.

There are two copy stacker capacities.

- 250 sheets for face-down copies
- 10 sheets for face-up copies

Documents fed through the automatic document feeder print at 600 dpi.

Paper used for copying has two possible paper sources.

- paper tray
- manual paper feeder

To Make Copies

- 1 Load the document(s) in the document tray.

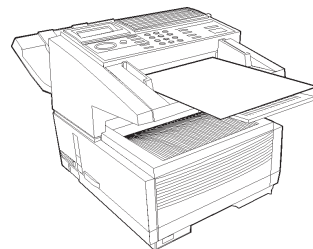

- 2 Press **Copy**. The display shows **Number of Copies**.
- 3 If only one copy is required, wait. The machine begins copying.
- 4 To make multiple copies, enter the number of copies you want. Use the numeric keypad.
- 5 Press **Copy** again. The machine begins making copies.

Manual Paper Feeder

Use the manual paper feeder to make a copy on paper different from the paper loaded in the paper tray.

- 1 Load the document in the document tray.
- 2 Fold down the manual paper feeder tray.

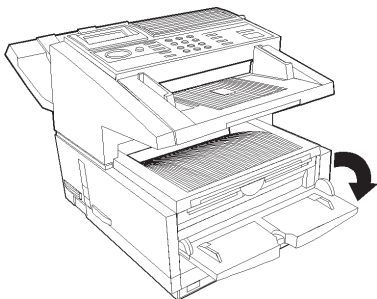

- 3 Insert a sheet of paper (face up) on the tray and push into the slot until the machine grabs hold of the paper.

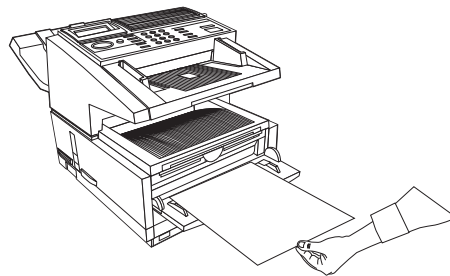

- 4 Press Copy.

- ! *If you are making more than one copy, feed paper continuously one sheet at a time.*

Face Up Stacking/Face Down Stacking

! *If the lever is set for face up, faxing is disabled.*

The machine can process copies in two ways: stacked with printed side up or with print side down. The position of the lever located on the side of the machine, above the power switch, determines how the copies are stacked.

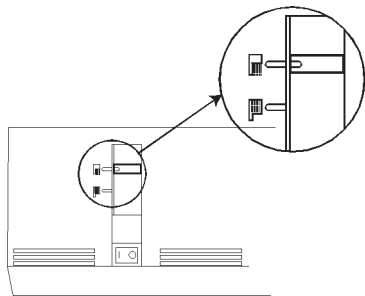

- 1 In the upper position, copies exit the machine face down.
- 2 In the lower position, copies exit face up.

You can use the “face up” position only when

- copying
- using PC Print (MFP option)

Sending a Fax to Multiple Locations

Group vs. Broadcast

There are two ways to send one fax to multiple locations using one fax session.

- Group
- Broadcast

- ! *Individual destination numbers included as part of either method may be saved (programmed) into your fax machine as One Touch or 2 or 3-digit Speed Dial numbers. These saved (programmed) numbers must exist before sending a fax.*

See “Programming Speed Dial Numbers.”

Group Fax

A group fax is a fax sent to several locations.

A group fax is meant to be repeated.

The group (a collection of destination numbers [where the fax is going] **IS** saved (programmed) into the machine.

The group is a collection of fax numbers to which you regularly or repeatedly send communications. This set of numbers is saved (programmed) into the machine.

- ! *Individual destination numbers included as part of the group fax may be saved (programmed) into your fax machine as One Touch or 2 or 3-digit Speed Dial numbers. The Group (a collection of individual destination numbers) can be saved.*

Broadcast Fax

A broadcast fax is a fax sent to several locations.

A broadcast fax is a one-time event (not meant to be repeated).

The broadcast (a collection of destination numbers [where the fax is going] **IS NOT** saved (programmed) into the machine.

- ! *Individual destination numbers included as part of the broadcast fax may be saved (programmed) into your fax machine as One Touch or 2 or 3-digit Speed Dial numbers. The Broadcast (a collection of individual destination numbers) cannot be saved.*

Group Faxing

What is a Group Fax?

If you often send a fax to many fixed locations, setting up these locations as a group will save time.

A group fax is a fax sent to several locations.

A group fax is meant to be repeated.

The group (a collection of destination numbers [where the fax is going to] **IS** saved (programmed) into the machine.

You can create up to 20 different groups of telephone numbers.

Each group may have a maximum of 230 locations.

Each group is listed by a group dial number.

Each group can be assigned a name (Group ID) for alphabetic searches.

! *The locations you use to create a group **MUST BE** programmed as One Touch, 2-digit, or 3-digit Speed Dials before you create a group. Refer to “Programming Speed Dial Numbers.”*

Programming a Group

! *The locations you use to create a group **MUST BE** programmed as One Touch, 2-digit, or 3-digit Speed Dials before you create a group. Refer to “Programming Speed Dial Numbers.”*

Print the Group Directory Report before programming a Group. This report is a reference of group numbers already programmed. See “Reports, Group Directories.”

- 1 Press **Menu/Exit** to enter the Menu.
- 2 Press **▼** to select **Location Program**, press **Enter**.
- 3 The cursor will be at Speed Dial, Press **▼** to select **Group**, press **Enter**.
- 4 Input a group dial number (from 1-20), press **Enter**.
- 5 Enter locations by pressing either a One Touch key or the Speed Dial number. Press **Enter**. Continue until all locations are entered. Press **Start**.
- 6 Enter a Group ID (name), then press **Enter**.
- 7 Press **Menu/Exit** to return to standby mode.

Deleting and Groups

- ! *Print the Group Directory Report before deleting a Group. This report is a reference of group numbers already programmed. See “Reports.”*

You can delete an entry in a group, several entries, or the entire group.

To delete an entry, perform the delete procedure for only that entry.

To delete several entries, perform the delete procedure for each entry you want to delete.

To delete a group, you must first delete all of the numbers assigned to the group. Repeat the delete procedure as many times as there are entries. When all entries are deleted, the group name is automatically deleted.

You DO NOT delete the assigned numbers from their Speed Dial locations. You DO DELETE the entries assigned to the group.

- 1 Press **Menu/Exit** to enter the Menu.
- 2 Press **▼** to select **Location Program**, press **Enter**.
- 3 The cursor will be at **Speed Dial**, Press **▼** to select **Group**, press **Enter**.
- 4 Input a group dial number (from 1-20), press **Enter**.
- 5 At **Select Locations(s)**, press **Enter**.
- 6 Press **▼** or **▲** to select the entry you want to delete, press **Clear** or **Enter**. The entry information displays.
- 7 Press **Clear**. The entry is now deleted from group.
- 8 To delete the group, repeat steps 6 and 7 for all entries in the group you want to delete.
- 9 Press **Menu/Exit** to return to standby mode.

Sending a Fax to a Group

1 Load your documents.

2 Enter the group.

There are two ways to enter the group.

By Name

By Number

By Name

Press the **Speed Dial Search** key.

Input the first character of the Group ID.

The group name will appear on the display.

By Number

Press the **Speed Dial Search** key.

Press the # key, and enter xx (xx is the number for the group).

Press the **Enter** key twice.

The group name will appear on the display.

3 Press the **Start** key.

Finding a Group Name

You can find a group name by using the

- Group Directory Report
- Speed Dial/Search

If you do not know the name of the group, use the Group Directory Report or use the Speed Dial/Search, enter the letter a, and scroll through the list.

If you know the name of the group, use the Speed Dial/Search, enter the first letter of the name of the group, and scroll through the list.

Group Directory Report

This report is a reference of group numbers already programmed. See “Reports.”

Using Speed Dial/Search

The Speed Dial/Search key allows you to access an alphabetical list of the Speed Dial and Group names programmed into your machine.

If you know the name of the group, use the first letter of the name of the group to search.

If you do not know the name of the group, use the letter “A” and scroll through the list.

! *All searches are done by the first character entered for the location name.*

Remember this when programming the name.

- 1 Press the **Speed Dial/Search** key. The display will show **ENTER 1-ST CHAR.**
- 2 Using the One-Touch key, enter the first letter of the name of the location you want to transmit to.
- 3 Repeatedly press ▼ to scroll through the list of location IDs beginning with that letter.

This list is an alphabetical list of ALL Speed Dials and Groups programmed into the machine.

Groups are indicated by a # before the name.

- 4 When the correct location is found, press the **Start** key to begin faxing.

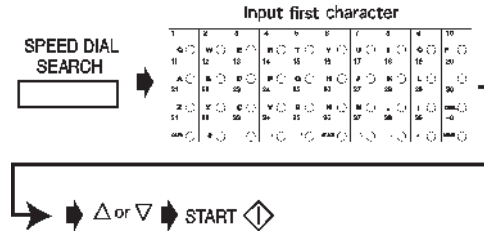

Broadcasting

What is a Broadcast Fax?

A broadcast fax is a fax sent to several locations.

A broadcast fax is a one-time event (not meant to be repeated).

The broadcast (a collection of destination numbers [where the fax is going] **IS NOT** saved (programmed) into the machine.

- ! *The locations you use during a broadcast CAN BE programmed as One Touch, 2-digit, or 3-digit Speed Dials before you create a broadcast. Refer to “Programming Speed Dial Numbers.”*

Sending a Broadcast Fax

- 1 Load the document.
- 2 Enter the programmed location. Use a One-Touch key, 2 or 3– Digit Speed Dial, Group Directory, or enter a number on the numeric keypad.
- 3 Press **Enter**.
- 4 Repeat Steps 2 and 3 until all locations for the broadcast are input.
 - ! *If Auto Start is set to ON (default setting) you will have 2 seconds between steps 2 and 3 (if using a Speed Dial and only after the first entry) to input the next location before machine begins dialing. To change this, set Auto Start (User Function #42) to OFF.*
 - To delete an entry, press ◀ to back up.
- 5 At this point, you have three options.
 - Press **Enter** to display the locations for the broadcast.
 - Press **Enter** twice to print the locations for the broadcast.
 - Press **Start** to begin faxing.

Advanced Operations

The advanced operations are:

- Delayed Faxing
 - Delayed Fax Transmission
 - Delayed Batch Transmission
- Priority Transmissions
- Confidential Faxes
- Call Forwarding
- Relay Faxing
- Polling Transmission (sending documents requested by another fax machine)

Delayed Faxing

What is Delayed Faxing?

Delayed Faxing allows you to send documents at a specified time and date. It frees you from having to manually start the transmission. You can scan the document and store the data in memory. The fax machine can send documents at different specified times (sessions). You can program a delayed transmission to occur at any time over the next three days.

The number of delayed transmission sessions varies according to the model of your fax machine.

The Konica FAX 9930 can be programmed for 30 sessions.

- ! *Use the 24-hour format to enter times.*
- *For example, 0800 is 8:00 AM, 2000 is 8:00 PM.*

Delayed Fax vs. Delayed Batch

A delayed fax transmission is one fax sent to one location, group, or broadcast, at a time and date specified by you.

A delayed batch transmission is a little more complicated.

In a delayed batch transmission, faxes to a single location are not sent until a specified time. The faxes are sent at the same time every day.

Imagine that your fax machine is located in the main office, and you send faxes to your sales force. Your machine can be programmed to hold all documents being sent to a fax number (salesperson) until a time you specify. When it is the specified time, all held documents are sent to the number.

The numbers programmed into One Touch Keys 31 through 40 are used for delayed batch transmissions.

- ! *Delayed Batch Transmissions can ONLY use One*
- *Touch Keys 31 through 40.*

Sending a Delayed Fax

- 1** Load the document(s).
- 2** Press **Menu/Exit** to enter Menu.
- 3** Press ▼ or ▲ to access **Delayed TX**. Then press **Enter**.
- 4** Press ▼ or ▲ to move between date and time settings, and ► or ◀ to move between columns.
- 5** Input the desired date and time using the numeric keypad, press **Enter** key.
Enter times following the 24-hour format. For example, 0800 is 8:00AM, 2000 is 8:00PM.
- 6** **Delayed TX** shows **Select Location(s)** on the display.
- 7** Enter the desired location using either Speed Dial numbers or the numeric keypad.
- 8** Press **Start**. The machine scans the document(s) into memory, and waits until the programmed time to begin transmission.
- 9** Above process can be repeated for up to x times (sessions) when memory is available.
x = the number of sessions available to your model fax machine
Konica FAX 9930, up to 30 sessions.
- 10** When the memory is full, you can still do one more transmission. Place the documents in the document tray and set the machine as instructed in steps 2-7.

Canceling Delayed Transmissions

To cancel a delayed transmission before it is sent:

- 1 Press **Stop**.
- 2 The display shows **Communication Cancel**.
- 3 The display shows Location ID or Tel. No. of the delayed transmissions currently programmed in the machine.
- 4 Press ▼ or ▲ to select transmission to cancel. Press **Enter**.
- 5 The Location ID and Tel. No. of the selected transmission will display. After confirmation, press **Clear**.
- 6 Selected transmission will be canceled.
- 7 For a delayed transmission from the document tray, press **Stop** again to remove the document.
- 8 Press **Menu/Exit** to return to standby mode.

Delayed Batch Transmission

In a delayed batch transmission, all faxes to a single location are held until a specified time. The specified time is a daily event (the faxes are sent at the same time every day).

Imagine that your fax machine is located in the main office, and you send faxes to your sales force. Your machine can be programmed to hold all documents being sent to a fax number (salesperson) until a time and date you specify.

When it is the specified time, all held documents are sent to the number.

Locations must be programmed into Speed Dial (One Touch) numbers 31-40.

To perform a delayed batch transmission, you must

- program the delayed batch destination number (One Touch numbers 31-40).
- set the batch TX time function
- send a fax as part of a delayed batch transmission

Program the Delayed Batch Destination Number

The destination number of the location receiving the Delayed Batch Transmission (where you are sending to) must be assigned to a One Touch Speed Dial.

You must use one of the One Touch Keys 31 through 40.

Refer to “Programming Speed Dial Numbers.”

Setting the Batch TX Time Function

- ! *Locations used for Delayed Batch Transmission must be programmed into Speed Dial numbers 31 through 40 before the Batch TX Time may be set.*

- 1 Press **Menu/Exit** to enter the menu.
 - 2 Press **▼** to select **Location Program**. Press **Enter**.
 - 3 Press **▼** to select **Batch TX Time**. Press **Enter**.
 - 4 Enter the Speed Dial number of the desired location.
Use the numeric keypad to enter the number.
Press **Enter**.
 - 5 When prompted, enter the desired time.
Press **Enter**.
- ! *Use the 24-hour format to enter times.*
 - *For example, 0800 is 8:00 AM, 2000 is 8:00 PM.*
Remember that delayed batch transmissions are sent at the same time every day!
- 6 Press **Menu/Exit** to exit.

Send a Fax as Part of a Delayed Batch

- 1 Load the document(s).
- 2 Press **Menu/Exit** key to enter the menu.
- 3 Press ▼ to select **Delayed Batch TX**, press **Enter**.
- 4 Enter the Speed Dial number of the desired location using the assigned One Touch key or the numeric keypad. Press **Enter**.

! *Locations used for Delayed Batch Transmission must be programmed into Speed Dial numbers 31 through 40.*

- 5 Location and transmission time set displays. Press **Start**.
- 6 The machine scans the document(s) into memory, and waits until the programmed time to begin transmission.
- 7 Repeat above steps 1-7 to prepare multiple sessions.

- ! *Use the 24-hour format to enter times.*
 - *For example, 0800 is 8:00 AM, 2000 is 8:00 PM.*
- The amount of available memory determines how many batch transmissions you may set. Once memory is filled, no more sessions will be accepted.*

Canceling Delayed Batch Transmissions

To cancel a delayed transmission before it is sent:

- 1 Press **Stop**.
- 2 The display shows **Cancel Communication**.
- 3 The display shows Location ID or Tel. No. of the delayed transmissions currently programmed in the machine.
- 4 Press ▼ or ▲ to select transmission to cancel. Press **Enter**.
- 5 The Location ID and Tel. No. of the selected transmission will display. After confirmation, press **Clear**.
- 6 The selected transmission will be canceled.
- 7 Press **Menu/Exit** to return to standby mode.

Priority Transmission

When you need to send a document immediately, use priority transmission.

With priority transmission, your urgent fax is processed before anything else.

A priority transmission document will be sent before

- any previously scanned documents
- any received (incoming) documents

Sending a Priority TX

- 1 Load the document(s).
- 2 Press **Menu/Exit** to enter the menu.
- 3 Press **▼** to select Priority TX, press **Enter**.
- 4 Input the desired location using a Speed Dial number or the numeric keypad.
- 5 Press the **Start** key.
- 6 The machine scans the document(s) into memory and assigns first priority for transmission.
- 7 If all memory is used, the display shows **Memory Overflow, Send Scanned Pages?**
- 8 To send scanned pages, press **Enter**.

Confidential Faxes

Facsimile machines are often located in open areas where anyone can look through the messages received. The confidential fax feature controls access to faxes.

A confidential fax is a fax sent or received to the secured memory of a machine. This secured memory is called a personal mailbox (or sub-address number).

Your machine can send and receive confidential faxes.

Confidential faxes require that:

- 1 Both communicating machines (the machine being sent from [sender] and the machine being sent to [receiver]) support compatible confidential fax standards.
 - both machines are Konica FAX (or compatible) products
 - or
 - both machines are equipped with a sub-address function
- 2 Confidential mailbox addresses be shared

On your machine, the address is the number (1 to 16) of the confidential mailbox.

Confidential Faxes may be

- Sent
- Received
- Programmed (Mailboxes)
- Printed

 ***Be sure to record both the address and password of each confidential mailbox. Keep the record in a safe place. If you forget a password, you will need to contact your Authorized Konica Dealer for assistance.***

Programming Personal (Confidential) Mailboxes

Speed access no. 04.

A personal (confidential) mailbox (or sub-address number) is the secured memory of a machine.

An address and password are used to access the personal mailbox. For your machine, the address is the number (1 to 16) of the mailbox.

Your machine can be programmed to manage 16 personal mailboxes.

When set up, each mailbox is opened as a Confidential Mailbox or Bulletin Polling Mailbox.

- Confidential
- Bulletin Polling (See Bulletin Polling)

Messages stored in a mailbox will not printed until the correct password is entered.

! *Be sure to record both the address and password of each confidential mailbox. Keep the record in a safe place. If you forget a password, you will need to contact an Authorized Konica Dealer*

! *The Mailboxes (numbers 1 to 16) are used for both Personal (Confidential) Mailboxes and Memory Polling (Bulletin). If you are using both features, remember that the number of available mailboxes is shared by the two functions.*

Creating a Personal (Confidential) Mailbox

- 1 Press **Menu/Exit** to enter the Menu.
- 2 Input speed access number 04, wait.
- 3 Enter the personal box number (1-16), press **Enter**.
This is the address.
- 4 Press ▼ or ▲ to select **Confidential**, press **Enter**.
- 5 Input a 4-digit numeric password (0000-9999), press **Enter**.
- 6 Repeat steps 3-5 until the desired number of confidential mailboxes is created (up to 16).
- 7 Press **Menu/Exit** to return to standby mode.

! Be sure to record both the address (number 1 to 16) and password of each confidential mailbox. Keep the record in a safe place. If you forget a password, you will need to contact an Authorized Konica Dealer for assistance.

! The Mailboxes (numbers 1 to 16) are used for both Personal (Confidential) Mailboxes and Memory Polling (Bulletin). If you are using both features, remember that the number of available mailboxes is shared by the two functions.

Changing a Password

Speed access no. 04.

- ! *A mailbox must be empty before it can be modified or closed.*

To change a password:

- 1 Press **Menu/Exit** to enter Menu.
- 2 Input speed access no. 04, wait.
- 3 Enter the number of the personal mailbox to be modified, press **Enter**.
- 4 Press **Enter** to select **Password Change**.
- 5 Input the existing (old) 4-digit numeric password, press **Enter**.
- 6 Input the new 4-digit numeric password, press **Enter**.
- 7 Press **Menu/Exit** to return to standby mode.

- ! *If the message **Illegal Operation** is displayed, the mailbox selected contains one or more messages. The mailbox must be empty before a change can be made.*

- ! *Be sure to record both the address and password of each confidential mailbox. Keep the record in a safe place. If you forget a password, you will need to contact an Authorized Konica Dealer for assistance.*

Closing a Mailbox

Speed access no. 04.

- ! *A mailbox must be empty before it can be closed.*

To close a mailbox:

- 1 Press **Menu/Exit** to enter Menu.
- 2 Input speed access no. 04, wait.
- 3 Enter the number of the personal mailbox to be modified/deleted, press **Enter**.
- 4 Press **▼** or **▲** to select **Close**, press **Enter**.
- 5 At **Close Box?**, press **Enter**.
- 6 At **Password**, enter the 4-digit numeric password. Press **Enter**.
- 7 Press **Menu/Exit** to return to standby mode.

- ! *If the message **Illegal Operation** is displayed, the mailbox selected contains one or more messages. The mailbox must be empty before a change can be made.*

Sending Confidential Faxes

When a confidential fax is sent, it is received to a personal mailbox (or sub-address number).

The personal mailbox (or sub-address number) is the secured memory of a machine. An address and password are used to access the personal mailbox.

Your machine can send messages to up to 64 designated mailboxes in remote machines.

- ! *You cannot access a mailbox without the address and password.*

To send a fax to a mailbox, you must know the address of the mailbox. For your machine, the address is the number (1 to 16) of the mailbox.

Be sure to record both the address and password of each confidential mailbox. Keep the record in a safe place. If you forget a password, you will need to contact your Authorized Konica Dealer for assistance.

To send a confidential fax:

- ! *You must know the address of the confidential mailbox you are sending to.*

- 1 Load the document(s).
- 2 Press **Menu/Exit** to enter the menu.
- 3 Press ▼ to select **Confidential TX**, press **Enter**.
- 4 Use the numeric keypad to enter the address of the confidential mailbox (up to 20 characters). Press **Enter**.
- 5 Use a Speed Dial number or the numeric keypad to enter the desired location.
- 6 Press **Start**.

Receiving Confidential Faxes

A confidential fax is received to a personal mailbox (or sub-address number).

The personal mailbox (or sub-address number) is the secured memory of a machine. An address and password are used to access the personal mailbox.

Your machine can receive confidential faxes from

Konica FAX (or compatible) machines
or
machines with a sub-address function

When you receive a confidential fax, it is stored in memory. It will not print until the proper password is entered.

- ! *If you wish to receive confidential faxes, you must provide your confidential mailbox address to the people sending you faxes. For your machine, the address is the number (1 to 16) of the mailbox.*

You cannot access a mailbox without the address and password.

A confidential fax is stored in memory and will not print until the proper password is entered.

Be sure to record both the address and password of each confidential mailbox. Keep the record in a safe place. If you forget a password, you will need to contact your Authorized Konica Dealer for assistance.

Knowing You've Received a Confidential Fax

Confidential Reception Report

Every time your machine receives a confidential fax, the Confidential Reception Report prints. This report lists the mailbox number(s) that received faxes.

Printing Confidential Faxes

! You must know the address and password of the confidential mailbox you wish to print from. The Confidential Reception Report has the mailbox address.

- 1 Press **Menu/Exit** to enter Menu.
- 2 Press to ▼ select **Print from Memory**, press **Enter**.
- 3 Press ▼ to select **Print Personal Box**, press **Enter**.
- 4 Enter the personal mailbox number (1-16) that is holding the message, press **Enter**.
- 5 Enter a 4-digit password for the mailbox, press **Enter**.
- 6 The message prints, and the machine returns to standby.

Tips:

- 1) *If no message is stored in the personal mailbox, No Data in Memory displays.*

Deleting Confidential Faxes

- ! *You must know the address and password of the confidential mailbox you wish to delete from. The Confidential Reception Report has the mailbox address.*

- 1 Press **Menu/Exit** to enter Menu.
- 2 Press to ▼ select **Print from Memory**, press **Enter**.
- 3 Press ▼ to select **Print Personal BOX**, press **Enter**.
- 4 Enter the personal mailbox number (1-16) that is holding the message, press **Enter**.
- 5 Enter a 4-digit password for the mailbox, press **Enter**.
- 6 When **Box No. =XX (Conf) Printing** displays, press **Stop**.
- 7 **Print Personal Box Memory Cancel?** displays.
Press **Enter**.
The fax is deleted and the machine returns to standby mode.

Call Forwarding

Your fax machine can automatically forward incoming faxes to a predetermined number. This number may be up to 40 characters (0-9, *, #, +, Pause, Hyphen, Space) long.

To use forwarding, you must

- 1 set the forwarding number.
- 2 set the Auto Answer mode to FWD.

Set a Forwarding Number

- 1 Press **Menu/Exit** to enter the menu.
- 2 Press ▼ to select **Location Program**, press **Enter**.
- 3 Press ▼ to select **Forwarding No.**, press **Enter**.
- 4 Enter the telephone number, press **Enter**.
- 5 Press **Menu/Exit** to return to standby mode.

Set the Auto Answer Mode to FWD

- 1 Press **Menu/Exit** to enter the menu.
- 2 Press ▼ to select **Setup**, press **Enter**.
- 3 Press ▼ to select **Machine Settings**, press **Enter**.
- 4 Press ▼ to select **Auto Answer mode**, press **Enter**.
- 5 Press ▼ to select **FWD**, press **Enter**.
- 6 Press **Menu/Exit** to return to standby mode.

Clear Forwarding Mode

- 1 Press **Menu/Exit** to enter the menu.
- 2 Press ▼ to select **Setup**, press **Enter**.
- 3 Press ▼ to select **Machine Settings**, press **Enter**.
- 4 Press ▼ to select **Auto Answer mode**, press **Enter**.
- 5 Press ▼ to select **Fax: Auto Receive Mode**.
Press **Enter**.
- 6 Press **Menu/Exit** to return to standby mode.

- ! *Messages received while the machine was set to forward*
- *will still forward.*

Forward on Paper/Toner Error

Your machine can provide a backup in case it runs out of toner or paper.

When a Paper/Toner Error forwarding number is programmed, and your machine runs out of paper or toner, any faxes received are forwarded to the programmed number.

Forward on Paper/Toner will not work if the machine is set for

- Forwarding Mode (FWD)
- Manual Receive Mode (TEL)
- Memory Reception Mode (MEM)

Setting a Paper/Toner Error Forwarding Number

- 1 Press **Menu/Exit** to enter the menu.
- 2 Press ▼ or ▲ to select **Location Program**, press **Enter**.
- 3 Press ▼ to select **Forward on P-ERR**, press **Enter**.
- 4 Enter the telephone number (up to 40 characters (0-9, *, #, +, Pause, Hyphen, Space)), press **Enter**.
- 5 Press **Menu/Exit** to return to standby mode.



Polled or confidential faxes cannot be forwarded.

Relay Faxing

What is an example of Relay Faxing? Imagine that you need to send a fax to a number of locations in another area code. With Relay Faxing, you (the relay initiating station) send one fax (transmission) long distance to another machine (the relay key station [hub]). The relay key station (hub) then sends the fax to all of the other machines/locations in the area code, at local rates.

Relay faxing allows one machine to send a document to another machine, which then forwards the document to a number of other locations. Two different machines are involved in transmitting a relay fax: the relay initiating station and the relay key station (hub).

Your machine can function as an initiating station and a relay key station (hub).

The relay key station (hub) can send a confirmation report to the relay initiating station when the relay fax session is complete. This confirmation report is called the Relay Broadcast Report.

- ! *The relay initiating station and the relay key station (hub) must coordinate efforts before a relay fax can be sent.*
- ! *Relay Faxing is different from group faxing. In Group Faxing, a fax is sent to a preprogrammed group of locations directly from the fax machine.*
- ! *At this writing, the Konica FAX 9930 is the only Konica machine that can function as a relay key station (hub).*
- ! *If you cannot access Relay Fax features, contact your service dealer. A Service Function setting (Technical Function 36) may require adjustment.*
- ! *All machines involved in a Relay Fax should be set to Auto Receive mode. See “Setting Basic Features, Setting the Answering Mode.”*

Using Your Machine as a Relay Initiating Station

Your machine can act as the relay initiating station, which starts the relay broadcast by sending the original documents.

Before you program your machine to initiate a relay broadcast, you must have the information listed below.

- Relay Password
- Relay Group Numbers
- Relay Key Station (Hub) number
- Contact number for Relay Broadcast Report

Get the relay password, the relay group numbers, and the relay key station (hub) number from the relay key station (hub) operator.

The contact number for the relay broadcast report is the number of the relay initiating station, programmed to a special location and in the format used by the relay key station (hub).

Relay Password

This is the 4-digit relay password that is programmed into the relay key station (hub).

Relay Group Numbers

These 2-digit numbers are the numbers of groups of locations programmed into the relay key station (hub).

Relay Key Station (Hub)

The relay key station (hub) is the fax unit that receives the original fax message and then automatically relays or broadcasts the message to other remote fax machines.

For this feature to be available, the relay key station (hub) must be a Konica FAX 9930.

Contact Number for Relay Broadcast Report

The relay key station (hub) can send a confirmation report to the relay initiating station when the relay fax session is complete. This confirmation report is called the Relay Broadcast Report.

To receive the report, the telephone number of the relay initiating station must be programmed into the specified Auto Dial location. The telephone number of the relay initiating station is called the Relay Report Number.

For your machine, that location is Auto Dial 99 (Relay Report Number).

- ! *Be sure to program the number in the format the relay*
- *key station uses for dialing. For example, be sure to include the access digit, if required.*

Programming the Relay Report Number

- 1 Press **Menu/Exit** to enter the menu.
- 2 Press ▼ to select **Location Program**, press **Enter**.
- 3 Press ▼ to select **Relay Report No.**, press **Enter**.
- 4 Enter the telephone number of the desired location using the numeric keypad (40 characters max.), press **Enter**.
- 5 Press **Menu/Exit** to return to standby mode.

Relay Broadcast Report

The relay key station (hub) can send a confirmation report to the relay initiating station when the relay fax session is complete.

This confirmation report is called the Relay Broadcast Report.

To receive the report, the telephone number of the relay initiating station must be programmed into the specified Auto Dial location. For your machine, that location is Auto Dial 99 (Relay Report Number).

- ! ***Be sure to program the number in the format the relay key station uses for dialing. For example, be sure to include the access digit, if required.***

The Relay Broadcast Report shows:

- the page count of the original fax
- the location identification of each destination machine the relay key station (hub) communicated with during the relay fax session
- the page count of each fax sent to each destination machine
- the results of each destination fax session

Initiating a Relay Broadcast

- 1 Load the document(s).
- 2 Press **Menu/Exit** to enter Menu.
- 3 Press ▼ to select **Relay Initiate TX**, press **Enter**.
- 4 Enter the password (4-digit number) of key relay station, press **Enter**.
- 5 Enter two-digit numbers of remote stations, press **Enter**.
- 6 Enter the desired location using the Speed Dial number or numeric keypad, press **Start**.
- 7 The machine will scan the document(s) into memory and begin faxing to the key relay station.
- 8 If all memory is used, the display will show **Memory Overflow, Send Scanned Pages?**
- 9 To send scanned pages, press **Enter**.

Using Your Machine as a Relay Key Station (Hub)

Your machine can act as the relay key station (hub), which receives the original document from the relay initiating station and then forwards the document to the destination machines.

Your machine can send a confirmation report to the relay initiating station when the relay fax session is complete. This confirmation report is called the Relay Broadcast Report.

Before you use your machine as a relay key station (hub), you must.

- program the number(s) of the destination machine(s) into your machine
- create a group or groups of the destination machine numbers
- create a relay password for your machine
- determine how the relay initiating station wants to handle the Relay Broadcast Confirmation Report
- determine if you want to print the relay fax when it arrives at your machine

- ! *Be sure to record your relay password. Keep the record in a safe place. If you forget the password, you will need to contact your Authorized Konica Dealer for assistance.*

Program the Destination Numbers

Collect the contact numbers for the destination machines to which you will forward the relay fax.

Each number must be programmed into your machine as a Speed Dial.

See “Programming Speed Dial Numbers.”

Create the Destination Group(s)

The Speed Dial numbers of the contact numbers (of the destination machines) must be programmed as a group or groups in your machine.

See “Sending a Fax to Multiple Locations, Group Faxing.”

You must provide the two-digit group number(s) to the relay initiating station.

Create the Relay Password

To program the Relay Password

- 1 Press **Menu/Exit** to enter the menu.
- 2 Press ▼ to select **Setup**, press **Enter**.
- 3 Press ▼ to select **ID Password**, press **Enter**.
- 4 Enter the the 4-digit relay password, press **Enter**.
- 5 Press **Menu/Exit** to return to standby mode.

You must provide this password to the relay initiating station.

Status of Relay Broadcast Report

Your machine [relay key station (hub)] can send a confirmation report to the relay initiating station when the relay fax session is complete.

This confirmation report is called the Relay Broadcast Report.

For your machine to send the report, the telephone number of the relay initiating station must be programmed into Auto Dial location 99 of the initiating station. The number must be programmed the way your machine (the hub) dials numbers.

- ! ***Be sure to program the number in the format the relay key station uses for dialing. For example, be sure to include the access digit, if required.***

The Relay Broadcast Report shows:

- the page count of the original fax
- the location identification of each destination machine the relay key station (hub) communicated with during the relay fax session
- the page count of each fax sent to each destination machine
- the results of each destination fax session

Printing the Relay Fax at the Hub

If you set Speed Access 27, Relay Print to ON, your machine will print any relay fax it receives from a relay initiating station.

To program the Relay Password:

- 1 Press **Menu/Exit** to enter the menu.
- 2 Input speed access number 27.
- 3 Press ▼ or ▲ to select **ON**, press **Enter**.
- 4 Press ▼ to select **Relay Report No.**, press **Enter**.
- 5 Press **Menu/Exit** to return to standby mode.

Sending Documents Requested by Another Fax Machine (Polling Transmission)

Sometimes it is useful to simply load your documents into your fax machine and set it to wait for the receiving fax machine to call and collect them. This is called setting your fax machine to be polled, or polling transmission. Your machine holds data in memory until transmission occurs.

An example of polling transmission is a hospital pharmacy facsimile contacting each unit's facsimile (Pediatrics, Cardiology, Critical Care, etc.) for prescription orders. Staff can load the prescription orders into the unit facsimile machine. The pharmacy facsimile contacts the each unit facsimile and requests the orders.

There are three types of polling transmission.

- Feeder (Document Tray) Polling
- Memory Polling
- Fax on Demand (Memory Polling [Bulletin])

Explanation of Polling Transmission Types

Feeder (Document Tray) Polling

In Feeder (Document Tray) Polling, you place the document to be polled in the document tray. A remote machine will then call and collect (poll) the document.

- ! *If you use feeder (document tray) polling, remember that the document remains in the machine until the unit is polled.*

Only one remote fax can poll your machine if feeder (document tray) polling is used.

Only the document placed in the feeder (document tray) can be polled.

Feeder (Document Tray) Polling is a one-time occurrence. It can only be repeated by re-loading the document.

Memory Polling

Memory Polling is very similar to Feeder (Document Tray) Polling. The difference is that the document is saved to memory, instead of occupying the feeder (document tray).

In Memory Polling, the document is saved to general memory, not a specific mailbox. When a document to be polled is saved to a mailbox, you are performing Memory Polling (Bulletin), not Memory Polling.

- ! *Only one remote fax can poll your machine if memory polling is used.*

Only the document saved in memory can be polled.

Memory Polling is a one-time occurrence. It can only be repeated by re-loading the document and saving it to memory.

Memory Polling (Bulletin)

In Memory Polling (Bulletin), the document to be polled is saved to a Confidential Mailbox.

Several remote machines can contact your machine and request the document.

You may also load several documents.

Memory Polling (Bulletin) allows for repeat polls. The remote machines can contact your machine and have the document(s) sent again and again.

Memory Polling (Bulletin) allows you to use your machine as a fax back system.

- ! ***The Mailboxes (numbers 1 to 16) are used for both Personal (Confidential) Mailboxes and Memory Polling (Bulletin). If you are using both features, remember that the number of available mailboxes is shared by the two functions.***

Memory Polling (Bulletin) allows any number of remote machines to contact your machine. The remote machines can retrieve the document as many times as needed.

Memory Polling (Bulletin) is designed to be repeated, by multiple remote machines.

Feeder (Document Tray) Polling

During Feeder (Document Tray) Polling, remote machines request (poll) documents placed in the feeder (document tray).

To set document tray polling:

- 1 Press **Menu/Exit** to enter the menu.
- 2 Press **▲** to select **Polling TX/RX**.
- 3 Press **Enter** to select **Polling TX**.
- 4 Press **▼** to select **Feeder Poll**, press **Enter**.
- 5 Load the document(s).
- 6 Display shows **Waiting to be Polled**.

- ! *If you use feeder (document tray) polling, remember that the document remains in the machine until the unit is polled.*

Only one remote fax can poll your machine if feeder (document tray) polling is used.

Only the document placed in the feeder (document tray) can be polled.

Feeder (Document Tray) Polling is a one-time occurrence. It can only be repeated by re-loading the document.

Memory Polling

During Memory Polling, remote machines contact your machine and request (poll) data directly from memory.

Setting Memory Polling

- 1 Press **Menu/Exit** to enter the menu.
- 2 Press ▼ to select Polling TX/RX.
- 3 Press **Enter** to select Polling TX.
- 4 Press ▼ to select **Memory Poll**, press **Enter**.
- 5 Load the document(s).
- 6 Document(s) are scanned and stored in memory, and display shows **Waiting to be Polled**.

! *Only one remote fax can poll your machine if memory polling is used.*

Only the document saved in memory can be polled.

Memory Polling is a one-time occurrence. It can only be repeated by re-loading the document and saving it to memory.

Memory Polling (Bulletin)

During Memory Polling (Bulletin), remote machine(s) contact your fax machine and request (poll) documents. The documents are stored in specified personal mailboxes. The remote machine(s) continue the request(s) until all stored documents in the specified mailboxes have been retrieved.

- 1 To use bulletin polling, you must
- 2 Create Personal (Bulletin Polling) Mailboxes
- 3 Provide the Personal (Bulletin Polling) Mailbox address (number) to the machine requesting documents. For your machine, the address is the number (1 to 16) of the mailbox.

- ! *Memory Polling (Bulletin) and Confidential Faxing share the same 16 mailboxes.*

Memory Polling (Bulletin) allows any number of remote machines to contact your machine. The remote machines can retrieve the document as many times as needed.

Memory Polling (Bulletin) is designed to be repeated, by multiple remote machines.

Create a Polling Mailbox

- 1 Press **Menu/Exit** key to enter **Menu**.
- 2 Input speed access no. 03, wait.
- 3 Enter the personal box number (1-16), press **Enter**.
- 4 Press **▼** or **▲** to select **Bulletin Polling**, press **Enter**.
- 5 Repeat steps 3 and 4 until the desired number of bulletin polling mailboxes has been created (up to 16).
- 6 Press **Menu/Exit** to return to standby mode.

Set Bulletin Polling

- 1 Press **Menu/Exit** to enter the menu.
- 2 Press **▼** to select **Polling TX/RX**, press **Enter**.
- 3 Press **Enter** to select **Polling TX**.
- 4 Press **Enter** to select **Bulletin Poll (Box)**.
- 5 Input personal mailbox numbers (1-16), press **Enter** after inputting each mailbox number.
- 6 When finished inputting mailbox numbers, load the document(s).
- 7 The document(s) will be scanned and stored in memory, **Bulletin Msg. in Mem** will display.

! *Memory Polling (Bulletin) and Confidential Faxing share the same 16 mailboxes.*

Printing Polling Documents in Memory

- 1 Press **Menu/Exit** to enter the menu.
- 2 Press ▼ to select **Print from Memory**, press **Enter**.
- 3 Press ▼ to select **Print Personal Box**, press **Enter**.
- 4 Enter the personal mailbox number (1-16) holding the document, press **Enter**.
- 5 The message prints, and the machine returns to standby.

Tips:

- 1) *If no message is stored in the personal mailbox, No Data in Memory will display.*
- 2) *If you want to delete a message without printing it, after inputting the mailbox number and pressing Enter, press the Stop key to stop the printing process. The message Print Personal Box Memory Cancel? will display. Press Enter and the fax will be deleted without printing.*

Dialing Another Fax Machine to Request Documents (Polling Reception)

Your machine can contact a remote fax machine and request documents from it. This is called polling or polling reception.

Your machine can poll only one machine at a time.

- 1 Press **Menu/Exit** to enter the menu.
- 2 Press **▲** to select **Polling TX/RX**, press **Enter**.
- 3 Press **▼** to select **Polling RX**, press **Enter**.
- 4 Enter mailbox numbers, maximum of 20 characters (0-9, space, *, #), press **Enter**.
- 5 Enter desired location using Speed Dial or the numeric keypad.
- 6 Press **Start**.

Printing Faxes Polled into Memory

Use this feature to

- print faxes you have polled from a remote machine
- print documents scanned into your machine for polling.

- 1 Press **Menu/Exit** to enter the **menu**.
- 2 Press **Enter** to select **Print from Memory**.
- 3 Press **▼** to select **Print Memory Poll**, press **Enter**.
- 4 Faxes stored in memory print. The machine returns to standby mode.

Cancelling Polled Faxes in Memory

- 1 Press **Stop**. Then press **Enter**.
- 2 Display shows **Memory Cancel?**
- 3 Press **Enter** to cancel faxes stored in memory.
- 4 Machine returns to standby mode.

Customizing Features and Operations

Many of your fax machine's features and settings can be changed to suit your needs. This section lists the functions you can change to customize machine operations.

- ! *When you press the Help button, a Help List and Function List print. These lists are very helpful when you are moving through the multi-level structure of the menu.*

Identifying Current Settings

The Configuration Report is a list of current settings.

Printing a Configuration Report

- 1 Press **Menu/Exit** to enter the menu.
- 2 Press **▼** to select **Report Print**, press **Enter**.
- 3 Press **▼** or **▲** to select **Configuration**, press **Enter**.
- 4 The report prints.
- 5 Press **Stop** to cancel printing.

Changing Operation Functions

Before making changes, print the Configuration Report. The Configuration Report is a list of current settings. It will help you identify the features and functions you want to change.

Printing a Configuration Report

- 1 Press **Menu/Exit** to enter the menu.
- 2 Press **▼** to select **Report Print**, press **Enter**.
- 3 Press **▼** or **▲** to select **Configuration**, press **Enter**.
- 4 The report prints.
- 5 Press **Stop** to cancel printing.

Changing Operation Functions

- 1 Press the **Menu/Exit** key to enter the menu.
- 2 Enter the speed access number of the operator function you want to change.
- 3 When the display shows the operator function you want, press **▼** or **▲** to select the setting, then press **Enter**
or
▶
- 4 Press **Menu/Exit** to return to standby mode.

List of Operation Functions

Remote Diagnosis

Speed access no. 14.

The remote diagnostics feature allows service personnel to remotely dial and service the machine. This setting should remain **OFF** unless a service representative has asked you to turn it ON.

Available settings are ON and **OFF**.

The default setting is **OFF**.

Transmission (TX) Mode Default

Speed access no. 15.

- ! **When you enter speed access number 15, you move**
- **directly into the resolution settings.**

This function sets the machine's default settings for original document condition and transmission scanning resolution (Type of Original and Resolution).

If you routinely send or receive faxes that require a different settings, use the Transmission (TX) Mode Default to change the settings to match your requirements.

During the programming sequence, the new default combination is shown on the display panel.

The default settings are standard (**STD**) and normal (**Normal**).

Memory Full Save

Speed access no. 17

With features like group dialing, dialing starts after an entire document or set of documents is read into memory.

When this function is set to ON, a message displays when memory becomes full and an operator time out seems likely during the dialing process.

When this function is set to OFF, data not read into memory is deleted automatically.

When set to ON, and memory fills up, all but the last scanned page can be sent to the specified location(s). The remaining page(s) can then be sent as a separate communication.

Available settings are ON and **OFF**.

The default setting is **OFF**.

Instant Dial

Speed access no. 18

In the **ON** state, the document is scanned into memory and dialing starts immediately. Although the function relies on memory availability, connection to the remote location is confirmed and the document transmitted faster when memory is available. If it is set to OFF, the machine first confirms contact with the remote location and then transmits the document reading from the document tray (without scanning into memory).

Available settings are ON and **OFF**.

The default setting is **ON**.

Restrict Access

Speed access no.19

This function controls whether or not machine operation is restricted.

When set to ON (if restriction IDs have been programmed), users must enter a password before being allowed access to the machine's functions.

When set to **OFF**, no password is required (even if restriction IDs have been programmed).

Available settings are ON and **OFF**.

The default setting is **OFF**.

ECM Function

Speed access no. 20

The error correction mode (ECM) function is provided to improve communications in areas where telephone line conditions are very poor.

Available settings are **ON** and OFF.

The default setting is **ON**.

Sender ID Switch

Speed access no. 23

This function determines if the Sender ID is to be printed on the transmitted fax. When set to ON, the ID is included on the fax.

Available settings are **ON** and OFF.

The default setting is **ON**.

- ! ***In the United States, FCC regulation states that fax machines must identify the sender and the telephone number of the sender on each page of every fax sent.***

Pulse Dial Rate

Speed Access no. 46

If the machine is set to Dial Pulse, this function controls the rate of the dialing pulses (which vary by country).

Available settings are **10**, 16 and 20 pps.

The default setting is MF (Modulated Frequencies).

See “Setting Basic Features, Dial and Incoming Call Parameter Settings.”

Pulse Make Ratio

Speed access no. 47

If the machine is set to Dial Pulse, this function controls the make rate of the dialing pulses.

Available settings are 33, **39** and 40%.

The default setting is **39**.

Pulse Dial Type

Speed access no. 48

If the machine is set to Dial Pulse, this function controls the type of pulse dialing it uses. Types of pulse dialing vary by country.

Available settings are *N*, 10-*N* and *N*+1.

The default setting is *N*.

T/F Timer Prg.

Speed access no. 62

When set to T/F, the machine will automatically distinguish between incoming voice and fax communications. The T/F timer controls how long the machine waits for the call to be answered before switching to FAX mode.

Available settings are 20 and 35 seconds.

The default setting is 35.

CNG Count

Speed access no. 65

When set either in the T/F or TAD modes, the machine detects the type of signal (calling tone, CNG) sent from the remote location and initiates fax reception if required. This function sets the CNG detection number.

The available settings are 1-5 times (numeric keypad input).

The default setting is 1.

Ring Response

Speed access no. 66

This function controls how long the machine waits before answering an incoming call.

The available settings are 1 ring, 5, 10, 15 and 20 seconds.

The default setting is 1.

Distinctive Ring

Speed access no. 67

Some telephone carriers offer a service called Distinctive Ring. Distinctive Ring lets you have different numbers on one line, each with its own distinctive ring. You can then use one number exclusively as a fax number without the expense of a second line. Your local telephone carrier can provide you with more information about this service, which usually has an additional charge.

Available settings are:

OFF (not detected)

ON (detected)

SET (programmed)

The default setting is **OFF**.

- ! *You must have your local telephone carrier's Distinctive Ring service.*
- ! *Your fax machine must be in FAX or PC answer mode, and the PBX dial parameter must be set to OFF. Other modes—TEL, TEL/FAX, or TAD—will override Distinctive Ring.*
- ! *This feature may not work properly if you have a telephone other than a genuine Konica optional handset connected to your fax machine.*

Setting Distinctive Ring

To set up your fax machine to recognize another ring pattern:

- 1 Press the **Menu/Exit** key to enter the menu.
- 2 Enter speed access number 67.
- 3 When the display shows the parameter you want, press ▼ or ▲ to select the setting, press **Enter**.
- 4 Press **Menu/Exit** to return to standby mode.

Memory Password

Speed access no. 05

This is a 4-digit numeric password used when the machine is operating in the Memory Only Reception Mode (MEM). When the machine is in this mode, and you don't know the password, you can't make changes or print memory data.

Only one memory password can be programmed in your machine.

Setting a Memory Password

- 1 Press **Menu/Exit** to enter menu.
- 2 Enter speed dial access no. 05, wait.
- 3 Enter 4-digit numeric password (0000-9999) using numeric keypad, press **Enter**.
- 4 Press **Menu/Exit** to return to standby mode.

- ! *Be sure to record the password. Keep the record in a safe place. If you forget the password, you will need to contact a n Authorized Konica Dealer for assistance.*

Cancelling a Registered Password

- 1 Press **Menu/Exit** to enter menu.
- 2 Enter speed dial access no. 05, wait.
- 3 Enter 4-digit numeric password (0000-9999) using numeric keypad, press **Enter**.
- 4 If the password matches the registered number, **Password Close?** displays. If numbers do not match, **Invalid Password** displays.
- 5 At **Password Close**, press **Enter** to confirm password cancellation.
- 6 Press **Menu/Exit** to return to standby mode.

Restricted Access ID

Speed access no. 06

This is a 4-digit numeric password that must be entered to use the machine when it is set in the Restrict Access mode.

Up to 24 passwords can be registered at one time.

- ! *User Function 19 (Restrict Access Mode) must be set to*
 - *ON before the Restrict Access ID may be set.*
- ! *Be sure to record all Restrict Access IDs. Keep the*
 - *record in a safe place. If you forget a Restrict Access ID, you will need to contact an Authorized Konica Dealer for assistance.*

To set restricted access ID

- ! *User Function 19 (Restrict Access Mode) must be set to*
 - *ON before the Restrict Access ID may be set.*
 - ! *Be sure to record the Restrict Access ID(s). Keep the*
 - *record in a safe place. If you forget the Restrict Access ID, you will need to contact a Service Dealer for assistance.*
- 1 Press **Menu/Exit** to enter menu.
 - 2 Enter speed access no. 06, wait.
 - 3 Enter department number (1-24), press **Enter**.
 - 4 Input 4-digit password (0000-9999) using the numeric keypad.
 - 5 If the number is already registered, **INVALID ID** displays.
 - 6 Input another 4-digit password, press **Enter**.
 - 7 Repeat steps 3-6 until all have been registered.
 - 8 Press **Menu/Exit** to return to standby mode.

To use restricted access ID

Enter the 4-digit restricted access ID (password) at the prompt for Enter ID [xxxx].

To cancel restricted access ID

- 1 Press **Menu/Exit** to enter menu.
- 2 Enter speed access no. 06, wait.
- 3 Enter department number (1-24), press **Enter**.
- 4 Enter a 4-digit password using the numeric keypad, press **Enter**.
- 5 If ID matches a registered number, **ID Close** displays. If ID does not match a registered number, **Invalid ID** displays.
- 6 At ID Close press **Enter** to confirm ID cancellation.
- 7 Press **Menu/Exit** to return to standby mode.

Service Function Settings

Service function settings affect the way a facsimile machine operates. If any of the following settings need to be changed, please contact the nearest Service Dealer and request service.

Long Document Scanning/Transmission

(Long Doc. Scan)

Normally the machine will not scan documents longer than 356 millimeters (14 inches). With this function set to ON, the machine is capable of scanning and transmitting a document continuously for up to one hour or 1500 millimeters (61.75 inches) whichever comes first, before a logical jam occurs.

MYD/DMY

This setting controls how the machine displays and prints the date (mm/dd/yy or dd/mm/yy).

Time/Date Print

This setting controls if and how the time and date are printed on faxes transmitted by the machine. The machine can be set to print/not print time and date, print time and date at the top of the first page only, or print time and date at the top of every page.

TSI Print

When TSI Print is set to ON, the telephone number of the sending machine prints at the top of each page of the fax.

The default setting is ON.

- ! ***United States law requires that this information appear on every facsimile.***

See “Setting Basic Features, Setting Your Fax Machine’s ID.”

Reports

Understanding Reports

Your machine provides useful reports that show the current settings, programming, and operations. Some reports print automatically after completion of operations. Refer to the reports listing below to determine which reports you may want to print. For instructions on printing a report, see “Reports, Printing Reports” or “Reports, *Report Name*.”

Printing Reports

Printing a Message Confirmation Report

After transmission, press the **Enter** key once (with no documents loaded) to see a report confirming your transmission on your machines display.

To print the report, press the **Enter** key a second time.

Printing Other Reports

- 1 Press the **Menu/Exit** to enter the menu.
- 2 Press **▲** to select **Report Print**, press **Enter**.
- 3 Press **▼** or **▲** until the report you want appears on the display. Press **Enter**.
- 4 Print all the reports you want, then press **Menu/Exit** to return to standby mode.

List of Reports

Printed from the Menu

- Activity Report
- Active Mem. Files
- Broadcast Confirmation Report (MCF)
- Phone Directory
- Group Directory
- Configuration Report
- Function List
- Protocol Dump
- Log. Report
- G3 Log. Report

- ! *Only Authorized Konica Dealers will access the*
- *Protocol Dump, Log. Report, and G3 Log. Report.*

Automatically Generated

- Message Confirmation Report
- Power Outage Report
- Broadcast Entry Report
- Confidential Reception Report

Activity Report

This report provides a record of your machine's last 30 communications. Information provided on this report includes:

- The total amount of time your machine spent sending faxes and the total amount of time spent receiving faxes.
- The date, time and duration (S,R-TIME) of each transmission or reception.
- The name or telephone number of the fax machine you were communicating with (DISTANT STATION ID).
- The communication mode used.
- The number of pages.
- The result.
- Service codes.

Printing the Activity Report

! *The Activity Report automatically prints after your machine completes 30 communications.*

- 1 Press **Menu/Exit** to enter the menu.
- 2 Press **▲** to select **Report Print**, press **Enter**.
- 3 Press **▼** or **▲** until the report you want appears on the display. Press **Enter**.
- 4 Print all the reports you want, then press **Menu/Exit** to return to standby mode.

Active Memory Files Report

This report provides a list of all messages stored in your machine's memory, including documents waiting for transmission and documents which have been received and not yet printed. Information provided on this report includes:

- The date and time at which the message was scanned into memory for transmission.
- The name or telephone number of the machine you were communicating with
- The communication mode used for each transmission or reception.
- The number of pages.
- The result.

Printing the Active Memory Files Report

- 1 Press **Menu/Exit** to enter the menu.
- 2 Press **▲** to select **Report Print**, press **Enter**.
- 3 Press **▼** or **▲** until the report you want appears on the display. Press **Enter**.
- 4 Print all the reports you want, then press **Menu/Exit** to return to standby mode.

Broadcast Confirmation Report

Use this report to confirm the results of a multiple-location transmission (broadcast). Information provided on this report includes:

- The date and time at which the broadcast started.
- The total amount of time used to complete the broadcast.
- For each location, the Location ID, the number of pages sent and the result of the communication.

Printing the Broadcast Confirmation Report

- 1 Press **Menu/Exit** to enter the menu.
- 2 Press **▲** to select **Report Print**, press **Enter**.
- 3 Press **▼** or **▲** until the report you want appears on the display. Press **Enter**.
- 4 Print all the reports you want, then press **Menu/Exit** to return to standby mode.

Telephone Directory

This report provides a complete listing of all of the telephone numbers programmed into your machine's Speed Dial numbers. The information includes:

- The Location ID and main fax number for each One Touch key and 2 and 3 digit Speed Dial number.
- The alternate number (OR) for each One Touch key.
- The parameter settings for each One Touch key.

Printing the Telephone Directory

- 1 Press **Menu/Exit** to enter the menu.
- 2 Press **▲** to select **Report Print**, press **Enter**.
- 3 Press **▼** or **▲** until the report you want appears on the display. Press **Enter**.
- 4 Print all the reports you want, then press **Menu/Exit** to return to standby mode.

Group Directory Report

This report provides a complete listing of all of the numbers programmed into a specific group. There is a separate report for each group. The information includes:

- Date and Time report was printed
- ID of the machine generating the report
- Group Number
- Group Name
- Location IDs programmed into the Group

Printing the Group Directory

- 1 Press **Menu/Exit** to enter the menu.
- 2 Press **▲** to select **Report Print**, press **Enter**.
- 3 Press **▼** or **▲** until the report you want appears on the display. Press **Enter**.
- 4 Print all the reports you want, then press **Menu/Exit** to return to standby mode.

Configuration Report

The configuration report provides a list of the current operational settings of your machine. The information includes:

- The current User Function settings (except for One Touch Parameter settings, which appear in the telephone directory).
- The Sender ID (ID=), TSI/CSI (TEL NO.), and call back number currently programmed into your machine.
- Your machine's current dial parameter settings.

Printing the Configuration Report

- 1 Press **Menu/Exit** to enter the menu.
- 2 Press **▲** to select **Report Print**, press **Enter**.
- 3 Press **▼** or **▲** until the report you want appears on the display. Press **Enter**.
- 4 Print all the reports you want, then press **Menu/Exit** to return to standby mode.

Function List

The Function List is a report of the structure of the menu for your product.

Use it as a reference while moving through the levels of the menu.

It is **NOT** a report of the current menu settings.

The Configuration Report provides a list of the current menu settings.

See “Reports, Configuration Report.”

Printing the Function List

Press **Help**.

Message Confirmation Report

This report provides information about your last single-location fax transmission or polling transmission.

Information in this report includes:

- The date of the communication.
- The total amount of time your machine spent sending or receiving (S,R-TIME).
- The Location ID or telephone number of the fax machine you were communicating with (DISTANT STATION ID).
- The communication mode.
- The number of pages.
- The result.
- Service codes.
- If any error occurred during the communication, a portion of the page, that experienced a problem, prints after the report.

! *The Result Code 0000 on an MCF Report means that the fax communication was successful.*

Printing the Message Confirmation Report

After transmission, press the **Enter** key once (with no documents loaded) to see a report confirming your transmission on your machines display.

To print the report, press the **Enter** key a second time.

Message Confirmation Report Options

Message Confirmation Report (MCF) is a very convenient feature that is often used on a daily basis to ensure that faxes were sent or arrived at the proper destinations. Use the following functions to set MCF parameters.

MCF (Single-Loc)

Speed Access no. 70

Set to ON, an MCF automatically prints for single location transmissions. When set to *OFF*, no report prints.

MCF (Multi-Loc)

Speed Access no. 71

Set to *ON*, single and multiple location transmission MCFs automatically print. When set to OFF, no report prints.

Image in MCF

Speed Access no. 72

Set to *ON*, a portion of the first page of the fax transmitted prints in the MCF. When set to OFF, no image prints in the report.

Err. Report (MCF)

Speed Access no. 73

Set to *ON*, an error report automatically prints if a fax communication is not successful.

When set to OFF, the report does not automatically print.

- ! *The Result Code 0000 on an MCF Report means that the fax communication was successful.*

Power Outage Report

Your machine has a 72-hour built-in battery backup in the event of a power failure. If power is interrupted to your machine, delayed transmissions, messages received into memory or other communications may be disrupted. As soon as power to the machine is restored, your machine automatically prints a power outage report to alert you.

Broadcast Entry Report

Each time you program a multiple-location transmission (broadcast), you can printing this report to confirm your entries. Information in this report includes:

- The Location ID of the One Touch keys and 2 and 3 digit Speed Dial codes you have selected.
- Telephone numbers you have manually entered.

Confidential Reception Report

This report prints automatically each time your machine receives a confidential message. Information in this report includes.

- The date the message was received.
- The total amount of time your machine spent receiving the message (S, R-TIME).
- The Location ID or telephone number of the fax machine you were communicating with (DISTANT STATION ID).
- The number of the mail box into which the message was received.
- The number of pages received.
- The result.
- Service codes.

Codes Used in Reports

Two types of codes are used in reports.

Result Codes

Communication Codes

Result Codes

Result codes indicate the results of communications.

BUSY

The other machine's line was busy or there was no answer.

CANCL

A message was erased after being held in memory for 10 days.

COMP.

A multiple-location transmission was completed.

COVER

The cover was opened during the communication.

NO

The transmission or reception failed due to a communication error.

OK

The communication was completed successfully.

PUNIT

This error code indicates a problem with the printing unit.
Contact your service person.

R_JAM

A paper jam occurred in your machine while it was receiving a fax, and it was unable to receive the entire message in memory.

S_JAM

A document jam occurred in the sending fax machine.

STOP

The **Stop** key was pressed, ending the communication session.

Communication Codes

Communication codes indicate the communication mode used for a communication.

B.C.

Multiple-location transmission (broadcast).

TX

A communication initiated by your machine.

RX

A communication initiated by a remote fax machine.

Maintenance

This section covers the procedures listed below.

- Cleaning the Scanner Path
- Replacing the Toner Cartridge
- Replacing the Image Drum
- Resetting the Image Drum Counter

Cleaning the Scanner Path

For the best possible scanning quality, clean the paper lint and dust accumulated in the area around the contact image sensor (**a**). Open the control panel and gently wipe the area over the scanner.

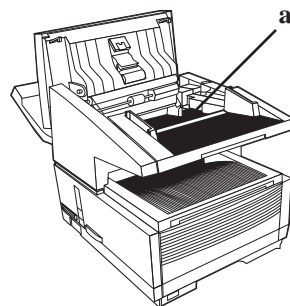

Replacing the Toner Cartridge

- ! *This machine will only operate using the toner cartridge specified by Konica for this machine. The use of any other toner will result in the display of an operation error and in machine malfunction.*

Refer to “Options and Accessories” for information on obtaining the correct toner cartridge.

- ! *Warning: Be careful when handling the toner cartridge. Do not let toner spill onto your clothing or other porous materials. If you experience any problems with toner, see the “Installation, Safety.”*

Toner Yield

The number of pages you can print with one toner cartridge depends on the type of documents you usually receive or copy.

A toner cartridge will print about 2,500 pages/letter size of standard business communications at a typical print coverage of 4% (equivalent of CCITT No. 1 test chart).

The first toner cartridge installed in a new image drum unit will have a decreased yield because the image drum unit has to be filled.

If your machine displays **REPLACE TONER CART**, replace the toner cartridge with a new one. However, if the print quality is good enough, you can continue to use the toner cartridge without replacing it until the print quality becomes unsatisfactory. If the print density becomes low even before your machine displays **REPLACE TONER CART**, gently wipe the lens surface of the LED array (see Step 8). If the print quality does not improve, replace the toner cartridge.

! **CAUTION:** When you open the top cover, you will see a label that reads: (CAUTION-HOT). This part is extremely hot—do not touch it.

- 1 Lift up on the document tray and swing it up and out of the way.

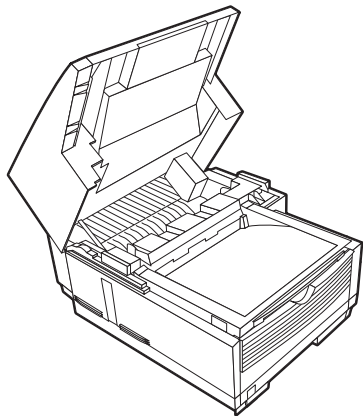

- 2 Press the release buttons located on both sides of the copy stacker. Lift up the stacker.

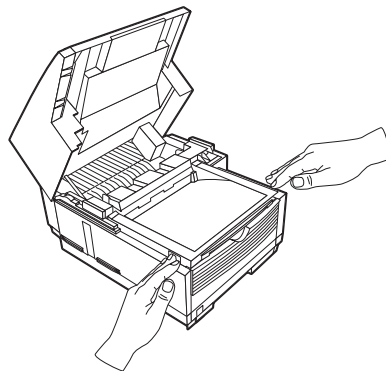

- 3 Pull the lock lever on the toner cartridge in the direction of the arrow.

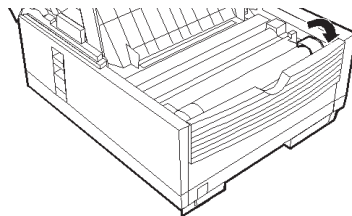

- ! **Warning: Be careful when handling the toner cartridge.**
- **Do not let toner spill onto your clothing or other porous materials. If you experience any problems with toner, see “Installation, Safety.”**

- 4 Carefully lift the toner cartridge out of the image drum unit. For disposal, place it in the plastic bag you received with your new toner cartridge.

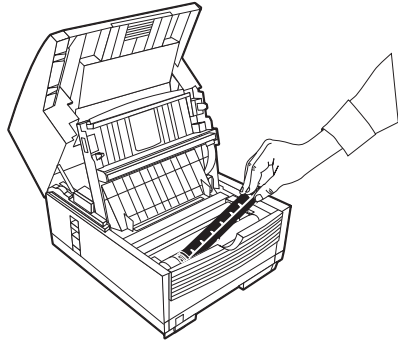

- 5 Unwrap the new toner cartridge and gently shake it to distribute the toner. Then carefully peel the tape from the bottom of the toner cartridge.

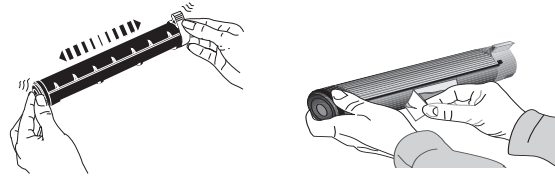

- 6 Holding the toner cartridge with the bottom down, insert the left side into the toner well, placing it under the tab (a).

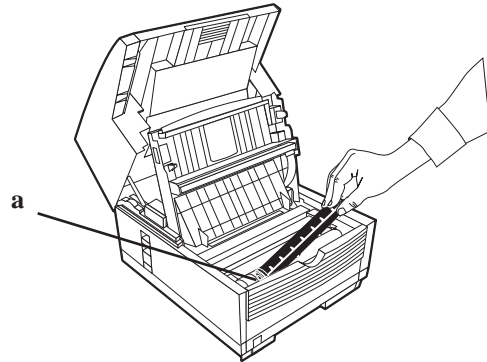

- 7 Lower the right side down into the toner well.

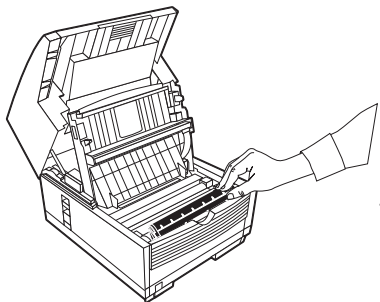

- 8 Push the lock lever (in the direction of the arrow) until it stops.

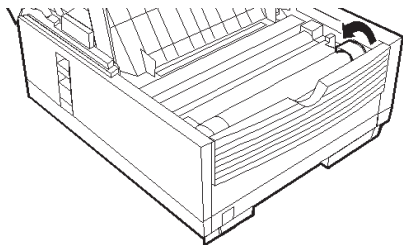

- 9 Use the cleaning wipe provided with your new toner cartridge. Gently wipe back and forth across the full length of the LED array. Use a clean section of the wipe with each pass.

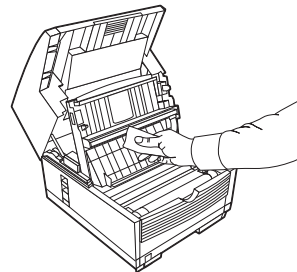

- 10 Close the copy stacker and document tray. Make sure the cover is firmly closed.

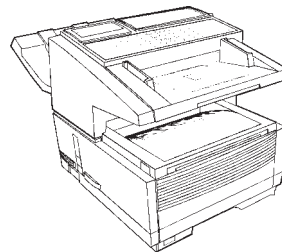

Replacing the Image Drum

- ! *This machine will only operate using the image drum unit specified by Konica for this machine. The use of any other image drum unit will result in the display of an operation error and in machine malfunction.*

Refer to “Options and Accessories” for information on obtaining the correct image drum unit.

- ! *Warning: Be careful when handling the image drum unit. NEVER touch the green surface. Do not let toner spill onto your clothing or other porous materials. If you experience any problems with toner, see “Installation, Safety.”*

- ! *Warning: Never expose the image drum unit to light for more than 5 minutes. Never expose the image drum unit to direct sunlight. Always hold the image drum unit by the ends. Never touch the surface of the green drum inside the image drum unit.*

- ! *CAUTION: When you lift up the document stacker, you will see a label that reads: (CAUTION-HOT).*

Image Drum Yield

The life of an image drum depends on a number of factors, including temperature and humidity, the type of paper you use, and the number of pages per job. The image drum cartridge should last about 20,000 pages for continuous printing, up to 14,000 pages at 3 pages per job, and about 9,000 pages at 1 page per job.

Replace the image drum when

- the faxes you receive are light or have vertical streaks in them and you are not out of toner
- your machine displays a CHANGE DRUM message
- your machine needs a new image drum unit.

- 1 Turn off the power switch.
- 2 Lift up on the document tray and swing it up and out of the way.

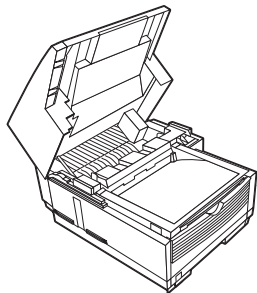

- 3 Press the release buttons located on both sides of the copy stacker. Lift up the stacker.

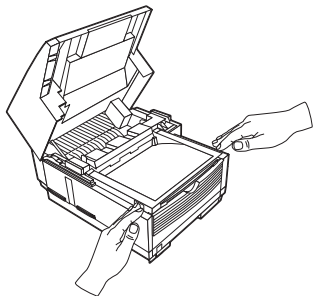

- 4 Firmly lift up to disengage the drum cartridge (with its toner cartridge), then lift it out. *Wrap it in the packaging materials from your new image drum cartridge, and discard it.*

! **Please abide by local laws when disposing of an image drum cartridge.**

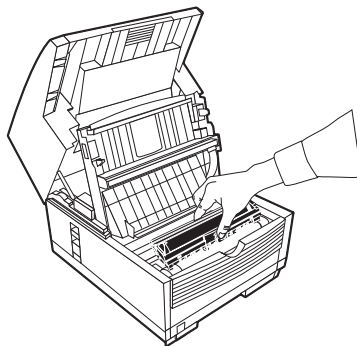

- 5 Insert the new drum cartridge. Press down firmly on both ends to lock the drum in place.

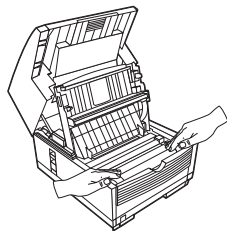

- 6 Lift out the toner well cover and discard.

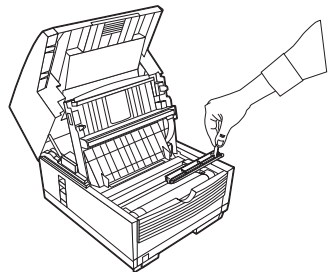

- 7 Install a new toner cartridge.
See “Maintenance, Replacing the Toner Cartridge.”

Resetting the Drum Counter

Use this function to reset the drum counter when you replace the image drum and to clear the **CHANGE DRUM** message.

To reset the image drum counter:

- 1 Press **Menu/Exit** to enter the menu.
- 2 Press **▼** until the > symbol is beside **COUNTER**.
- 3 Press **Enter** twice.
- 4 Press **Clear** twice.
- 5 Press **Menu/Exit** to return to standby mode.

Dual Line

What is Dual Line?

A fax machine with dual line has two modems. Dual line expands the functionality of your machine.

Two phone lines, each with a unique number, must be used with the unit to fully use the dual line feature.

With two phone lines, the unit can handle more fax traffic.

The second line may be programmed to send and receive, send only, or receive only.

For Line 1, you adjust the answering mode, dial, and incoming call options.

For Line 2, you adjust the Option Line Type.

Benefits of Dual Line

A fax machine with dual line gives you the work capacity of two fax machines in the space of one.

A fax machine with dual line makes an excellent relay key station (hub) for relay faxing. If both lines are available for transmission (sending), the relay fax process is done in half the time of a single-line machine.

A dual line machine makes it possible to always have a line dedicated to receiving faxes.

Basic Operations

- Dual Line requires two telephone lines, each with a unique telephone number.

! ***Both lines must be the same type (PSTN or PBX).***

- ***They must both be analog lines.***
- All transmissions using the second line are done from memory.
- The second line may be programmed to send and receive, send only, or receive only.

For Line 1, settings are programmed through the answering mode, dial, and incoming call options.

For Line 2, you set the Option Line Type.

! ***Set the Option Line Type before using the second line.***

- You control the use of the two lines of your Dual Line machine by the way you

- 1 program your machine
- 2 share the telephone numbers of the lines

Be careful how you share the telephone numbers.

Make sure the distribution of the numbers matches how you want to use the machine. If you want one line to *only* transmit (send) faxes, don't give out that number!

- The machine will **ALWAYS** try to transmit (send) using the first line before trying to use the second line.

- The second line does not have a speaker.
- Do not connect any external devices (such as an external phone) to the second line.
- When working with a Dual Line fax machine, remember that there are two TSIs (Transmit Sender Identifications). Each line has its own TSI. Refer to “Setting Basic Features, Setting Your Fax Machine’s ID.”
- When working with a Dual Line fax machine, remember that there is only one Sender ID, not two. You are sending from one location (Sender ID), which uses two lines.
- Some phone companies offer an automatic rollover feature as a service. Your fax machine will work with this feature. Contact your phone company for more information on the rollover feature.

Unpacking

Remove contents from the carton. Be sure that all the items listed below are included.

- ! *If any items are missing, contact Konica immediately.*
- *Keep your packing materials and carton in case you need to ship or transport the unit.*

- 1 Fax Machine
- 2 Toner cartridge
- 3 Image drum (inside machine)
- 4 Power cord
- 5 Telephone line cord(s)
- 6 Document Stacker
- 7 Documentation

User's Manual

Warranty Information

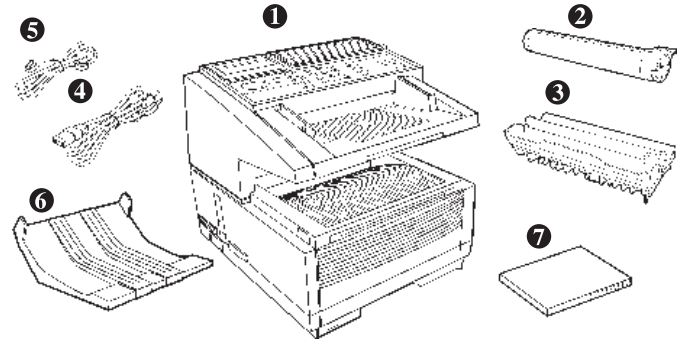

Connecting to the Second Telephone Line

- 1 The primary / first telephone line is connected to the LINE (1).

See “Installation, Setting Up Your Machine, Connecting to the Telephone Line.”

- 2 The second telephone line is connected to the second line jack [dual line access] (2).
- 3 Insert the other end into the wall jack for the second telephone line.

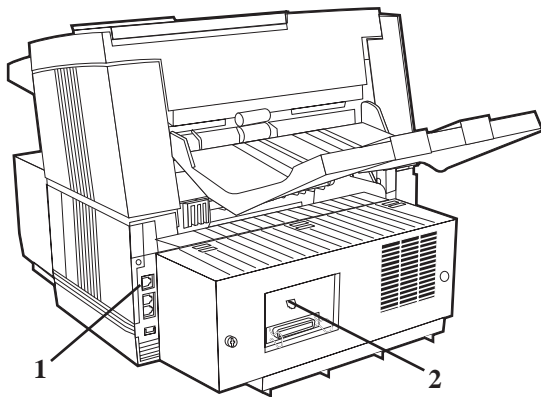

Displays, Reports, and Beeps

The display usually shows the status of the first telephone line. Press **HELP** to display the status of the second telephone line.

The end of a communication (a fax is sent or received) is indicated by a beep. Any beeps are for the line (first or second) being displayed. No beeps sound for the line not being displayed.

Continuous Tone, Speed Access no. 63 must be set to ON if you want to know when the second line is active. The second line does not have a separate audible alarm.

When looking at a report, any information related to the second line is marked with a “#” symbol.

Setting the Option Line Type for the Second Line

The second line type may be set to:

- Send (transmit) only (TX)
- Receive only (RX)
- Send and Receive (ALL)

- 1 Press **Menu/Exit** to enter the menu.
- 2 Input speed access no. 31 (Option Line Type)
- 3 Press ▼ or ▲ to select the desired mode, press **Enter**.
- 4 Press **Menu/Exit** to return to standby mode.

Setting Memory Transmissions to Use the Second Line

! *You must set the Option Line Type for the Second Line before programming Delayed Transmissions (Memory) to use the Second Line.*

The Option Line Type must be set to TX or ALL for use with the Delayed Transmission (Memory) function.

For more information on Delayed Transmission, see “Advanced Operations, Delayed Fax Transmissions.”

Options and Accessories

Obtaining

Before you order, have the correct part number and description of the item.

- Consult the dealer where you purchased your fax machine.
- Consult a Konica Authorized Sales and Service Dealer.
- Order toll-free by phone at 1-800-825-5664 using a major credit card.
- Check office supply catalogs or your local stationery store. Most carry Konica brand supplies.

! *Important: This machine will only operate using the consumables and options specified by Konica for this facsimile machine. The use of any other consumables or options will result in the display of an operation error and in machine malfunction.*

Part Numbers

Consumables

Part Number	Description
950-133	Toner Cartridge Kit, Type 5 TL
950-139	Image Drum Kit, Type 5 (F)

Options

Part Number	Description
950-118	2 MB Memory Expansion Kit
950-119	4 MB Memory Expansion Kit
950-127	2 nd Paper Tray Kit (UST-550)
950-117	Multifunction Printer (MFP) PC Interface Kit

- ! *For the latest product and technical support information, visit the Konica Web site:*

<http://www.Konicabt.com>

Descriptions

The following options are available for enhancing the operation of your fax machine.

The options and accessories available for your machine will depend upon the model of your machine.

Second Paper Tray

The second paper tray has a 500 sheet paper capacity.

With the second paper tray installed, the machine has a 750 sheet paper capacity (250 sheet standard tray plus 500 sheet second tray).

When the main tray runs out of paper, the machine switches to the second tray for uninterrupted printing.

Handset

The optional handset connects directly to your fax machine and works like a telephone.

Multifunction Printer (MFP) PC Interface Kit

The MFP PC Interface Kit is a software package that allows your fax machine to interface with a computer, giving you a multifunctional capable fax machine. With the MFP PC Interface Kit, your fax can function as a printer, scanner, copier and PC-based fax machine. The kit also includes a parallel cable for connection with your computer.

Memory Expansion

Several memory expansion cards are available.

Each has a different memory storage capacity.

All page numbers given are APPROXIMATES.

Your results may vary, depending on the nature of your pages.

An expandable memory slot is located under the back cover of the machine.

- ! *Only one memory slot is available in your machine.*
- *Therefore, only one of the available memory options may be installed at one time.*

You must have the 8 MB expansion card to utilize the 600 dpi TX feature.

2 MB

Capacity:

160 pages of Option 2 MB memory

360 pages of Standard 4 MB memory

520 pages total

4 MB

Capacity:

320 pages of Option 4 MB memory

360 pages of Standard 4 MB memory

680 pages total

8 MB

This item is called the 600 dpi TX Kit.

Capacity:

640 pages of Option 4 MB memory

360 pages of Standard 4 MB memory

1,000 pages total

- ! *You must have the 8 MB expansion card to utilize the 600 dpi TX feature.*
- *600 dpi TX feature.*

Problem Solving

This section lists the most common problems you may encounter while using this machine.

Printing a Cleaning Page

If you notice repeating marks or imperfections on your printouts, try printing a cleaning page before you replace the image drum.

Cleaning page process

- Removes residual impurities from printing surfaces.
- Reduces problems such as repeating marks, blotching, and shading.

To print a cleaning page

- 1 Press the **Menu/Exit** key to activate the menu mode.
- 2 Press **▼** continuously until **Printer Cleaning** displays.
- 3 Press **Enter**. After a moment the cleaning page prints.

Clearing a Document Jam

When a document jam occurs, your machine beeps and an error message appears in the display. If the jammed document appears to be positioned straight in your feeder, press the **Stop** key to try to feed the document the rest of the way through the feeder. If this fails, follow the instructions below.

- 1 Turn off the power switch.
- 2 Lift the document tray up and back on its hinges.

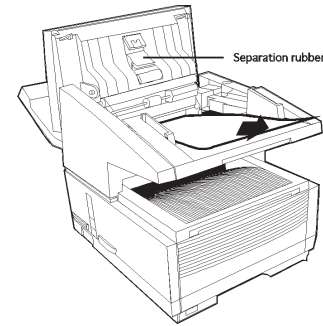

- 3 *Open the control panel fully, being careful not to damage the separation rubber (1).*
- 4 Pull out the jammed document.
- 5 Return the document tray to its original operating position, and push down until it locks in place.
- 6 Turn the power switch back on.

Clearing a Printing Paper Jam

If your machine displays PAPER JAM or NO PAPER when the paper tray still contains paper, there may be one or more sheets of paper jammed in the machine. To clear a paper jam, follow the instructions below.

! *If you are experiencing frequent paper jams, it may be due to the type of paper you are using. For best results, select a paper which has been developed specifically for photocopying or laser printing. Be sure to fan the paper before loading it into your paper tray.*

! *CAUTION: If you open the top cover, you will see a label that reads: (CAUTION-HOT). This portion is extremely hot—do not touch it under any circumstances.*

- 1 Turn off the power switch.
- 2 Grasp the document tray from the bottom and lift up, swinging it up and back out of the way.

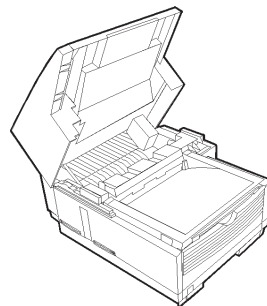

- 3 Press on the latches on both sides of the copier stacker until the cover of the image drum compartment is released and pops up. Lift up and back, revealing the image drum.

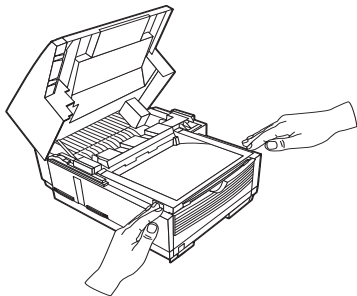

- 4 Grasp the image drum and lift it out of the machine. Set it aside on a clean, dry surface out of direct sunlight.



Warning: *Do not touch the green drum surface.*

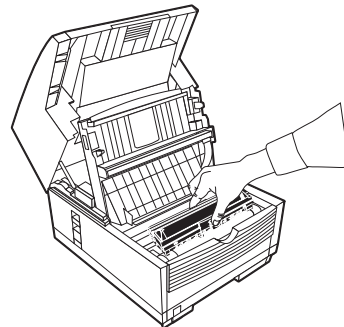

5 Pull out any paper caught inside the machine.

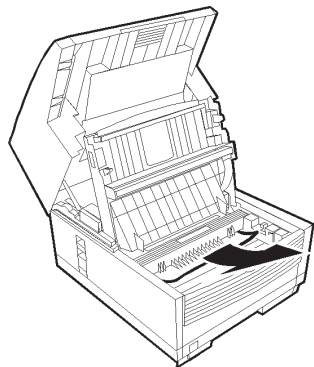

6 Pull out the paper tray.

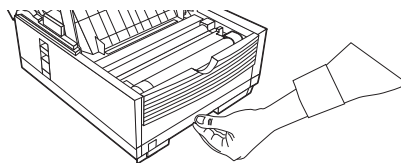

7 Remove any paper caught in the feeder and any damaged paper in the tray.

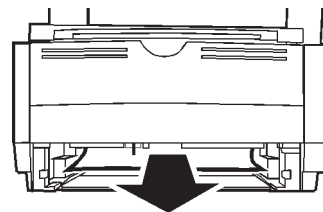

- 8 Load the paper tray, making sure the paper is below the “Paper Full” marking.
- 9 Slide the paper tray back into the machine until it latches in place.
- 10 Place the image drum unit back into the machine.
- 11 Close the cover to the image drum compartment, pushing down on it until both latches catch.
- 12 Return the document tray to working position.
- 13 Turn the power switch back on.

! ***WARNING: Never expose the image drum cartridge to light for more than 5 minutes. Never expose the image drum cartridge to direct sunlight. Always hold the image drum unit by the ends. Never touch the surface of the green drum inside the image drum cartridge.***

Display Panel Messages

This section lists the status and error messages that may appear on your machine's display panel, and explains what they mean and how to correct any problem they indicate.

Normal Display in Standby Mode

Under normal operating condition, information is displayed on the top and bottom lines of the display.

The top line shows the time and the answering mode.

Answering modes options are:

FAX, TEL, PC, T/F or TAD.

The bottom line shows the amount of memory available.

Error Messages

14:14: FAX

COVER OPEN

Cover open: The upper cover is not closed. First check to be sure that the image drum is seated correctly and the toner cartridge is installed properly. Then, check to see that the toner cartridge lock lever is pushed completely forward until it stops. Press down firmly on the cover to make sure it is closed and latched.

NO PAPER

CHECK PAPER SUPPLY

The paper tray is out of paper. Add more paper.

PAPER JAM

CHECK PAPER OR PATH

Jam: Paper is jammed feeding from the paper tray into the printer. Or, paper may be jammed inside the printing mechanism under the image drum. Check the paper path and remove any jammed paper.

See “Problem Solving, Clearing a Paper Jam.”

DOCUMENT JAM

CONFIRM AND STOP

A document being faxed or scanned has jammed in the scanner.

See “Problem Solving, Clearing a Document Jam.”

RELOAD DOCUMENT

Paper-feed error: A document to be faxed or scanned has not fed into the scanner properly. Remove the document and reload it into the document tray.

14:14 :FAX

CHANGE DRUM SOON

Image drum alarm: The image drum is nearing the end of its projected life. Make sure a new drum is available, and replace the drum when print quality begins to deteriorate.

See “Maintenance, Replacing the Image Drum.”

TONER LOW

REPLACE TONER CART.

or

REPLACE TONER CART.

Toner low: Toner is running low in the toner cartridge. Replace the cartridge as soon as possible. When you close the cover after replacing the toner cartridge, the message clears.

See “Maintenance, Replacing the Toner Cartridge.”

PRINTER ALARM 2:TEL
REFER TO USER GUIDE

or

PRINTER ALARM 3:TEL
REFER TO USER GUIDE

or

PRINTER ALARM 4:TEL
REFER TO USER GUIDE

For **PRINTER ALARM 3:TEL**

If you have the second paper tray installed, and the manual feed cover is moved, the machine will display this message.

The manual feed tray door must remain open when a second paper tray is installed.

Make sure that the second paper is correctly installed.

The error should clear.

For all **PRINTER ALARM** messages

Open and close the cover. If this does not clear these messages, turn off your machine and call for service.

INVALID TONER CART.

REFER TO USER GUIDE

This error will occur if an incorrect toner cartridge is installed. **This machine will only operate using toner cartridges specified by Konica for use in this machine.** If you are using the correct toner cartridge, open and close the cover. If this does not clear the message, turn off the machine and contact the nearest authorized Konica dealer for service.

INVALID DRUM CART.

REFER TO USER GUIDE

This error will occur if an incorrect image drum cartridge is installed. **This machine will only operate using image drum cartridges specified by Konica for use in this machine.** If you are using the correct drum cartridge, open and close the cover. If this does not clear the message, turn off the machine and contact the nearest authorized Konica dealer for service.

Counters

Your machine keeps track of the number of pages it has printed or scanned. If you are experiencing a problem, a service person may ask you to check these counters.

- ! *For some of the counters, the Service Bit must be set to ON. Your service person will assist you with setting the service bit.*

Accessing the Print/Scan Counters

- 1 Press **Menu/Exit** to enter the menu.
- 2 Press ▼ to select **Counter**, press **Enter**.
- 3 Press ▼ or ▲ to select the counter you want. Press **Enter**.
- 4 Press **Menu/Exit** to return to standby mode.

Resetting the Image Drum Counter

After you have replaced the image drum cartridge, use this function to reset the drum counter.

See “Maintenance, Replacing the Image Drum Cartridge.”

- 1 Press **Menu/Exit** to enter the menu.
- 2 Press ▼ until the > symbol is beside **COUNTER**.
- 3 Press **Enter** twice.
- 4 Press **Clear** twice.
- 5 Press **Menu/Exit** to return to standby mode.

Problem Checklist

Your fax unit is a complex machine with many features and functions that allow it to operate in different ways. Many problems you experience may be due to improper programming. If you are experiencing a problem, read through the list of problems and solutions before calling your dealer.

The display is blank.

Check the power cord to make sure that it is firmly plugged in and verify that the power switch is in the ON position. Check your wall outlet to make sure that it has power.

Nothing happens when you press the control panel keys.

Turn the machine off, wait 10 seconds, then turn it on again.

The display tells you to replace paper even though there is paper in the paper tray.

Make sure that the paper is firmly stacked in the tray. Check for a paper jam.

Your documents jam.

- Check the document for wrinkles, tears or other damage.
- Make sure there are no staples or paper clips and that the paper is clean and dry.
- Make sure the document is not wider than your machine can load.
- Try making a copy of the document on a photocopier and faxing the copy.

Your machine won't dial.

Check the power cord and wall outlet.

Make sure that your telephone line (not your external telephone or handset) is connected to the LINE outlet on the back of your machine.

If you have an external telephone connected, lift the handset and check for a dial tone.

If you do not hear one, there may be a problem with your telephone line.

If you do hear a dial tone, your machine may be using the wrong dialing method (pulse or tone) for your area.

If you hear changing tones instead of dialing pulses and you know that your area uses pulse dialing, refer to Tone/Pulse (MF/DP) [Speed Access 45] in "Setting Basic Features, Dial and Incoming Call Parameter Settings."

The display shows a communication error:

This alarm indicates any of a number of problems:

- You may be trying to communicate with an incompatible fax machine. Your machine can only communicate with ITU-T Group 3 fax machines.
- The remote machine may not be able to perform the function that you want, such as polling or confidential messages.
- The remote machine may also be out of paper or experiencing a paper jam.
- Bad telephone line conditions can also cause communication errors. Try sending the fax again and check to make sure you are dialing the correct telephone number.
- You have to dial a prefix number to get an outside line, or if you are dialing internationally, you may need to enter a pause (using the Pause One Touch key) after the dial prefix or international dialing code to tell your machine to wait for a dial tone.
- If you have frequent problems communicating with a particular remote fax machine, try programming the number into one of your One Touch keys and then changing the Communication Parameters for that One Touch key. See “Programming Speed Dial Numbers.”
- Your machine or the remote fax machine may need servicing. Try sending a fax to another location to check your machine.

You sent a fax but the image the remote fax machine received was very poor.

If your document had a lot of small type, complex illustrations, photos, or was very light or very dark, try changing your Transmit Resolution and Type of Original settings.

See “Basic Faxing Operations, Loading Documents.”

Copy the document on your machine to see how it will transmit. The problem may be caused by telephone line interference. Try sending the document again later.

You keep getting reports you do not want.

Check your user function settings and turn off the reports you do not want.

See “Reports, Message Confirmation Report Options.”

You sent a fax but it was received completely blank.

Make sure that you have loaded your document face down.

The image received on your machine was very poor

Contact the person sending you the fax and ask them to change their Resolution and Type of Original settings. Ask the person to make a copy of the document on their fax machine to ensure that it is working properly. Then ask them to send the fax again. If you still have a problem, try making a copy of a document on your machine to make sure it is working properly.

You tried dialing using One-Touch or 2-3 digit Speed Dial but nothing happened.

Make sure that something is programmed into the Speed Dial key you are using. Check the fax number to make sure it was entered correctly.

See “Programming Speed Dial Numbers.”

When you are dialing with an 2-3 digit speed dial code, be sure to press the Speed Dial/Search key before you enter the code.

Your machine does not answer the phone or receive faxes.

First check to see that the power cord is connected to the AC outlet. Also check the reception mode you are using. Your machine will not automatically receive faxes in manual answering mode [TEL].

See “Setting Basic Features, Setting the Answering Mode.”

Your received documents are light or have vertical streaks on them and you are not out of toner.

Gently wipe the lens surface of your machine’s LED array and then see if the machine works properly.

See “Maintenance, Replacing the Toner Cartridge.”

If your machine still does not work properly, remove the image drum unit.

See “Maintenance, Replacing the Image Drum.”

Tap the toner cartridge, and gently shake it from side to side several times to redistribute toner. **Be careful!** Some toner may spill from the cartridge.

If this does not work, you may need to replace your image drum cartridge. For information on obtaining a replacement image drum cartridge, see “Options and Accessories.”

You set your machine for delayed transmission but it did not send.

Check the display to make sure that you have set your machine’s clock to the correct time.

See “Setting Basic Features, Setting the Date and Time.”

Your machine disconnected before you could answer a voice request.

You must answer a voice request while the warbling tone is being emitted. When you hear the warbling tone, pick up the handset.

Your machine will not poll a remote fax machine.

Call the person at the remote fax machine and make sure that they have loaded documents and set their fax machine in polling transmission mode.

Your machine is connected to a PBX and you can't dial out.

You must enter your dial prefix before the telephone number for each number that you dial or program into your machine. Your machine must also be programmed for PBX operation before it will work.

See "Setting Basic Features, Connecting to a PBX."

You want to answer an external telephone but your machine always answers first.

If you are using an external telephone, change your machine's ring response user function setting.

See "Customizing Features and Operations, Changing Operation Functions, Restrict Access."

Your received faxes sometimes look distorted.

If the document received is wider or longer than the paper you have loaded into your paper tray, your machine automatically reduces the length of the document to fit on your paper.

This type of problem could be communication related.

The document may have jammed during scanning.

If the document is unreadable, ask the sender to fax the document again.

You are constantly receiving unsolicited advertising on your machine.

Try using the closed network function.

See "Basic Faxing, Rejecting Unsolicited Fax Messages."

Your machine does not immediately switch to TEL mode when you make or receive a voice call.

Try pressing the **Stop** key. Your machine will return to standby mode so that you can converse. This condition may happen infrequently due to telephone line conditions, or the type of external telephone used. If this problem happens often, consult your service representative.

Your machine receives faxes, but doesn't print them.

Your machine may be out of paper.

Check the paper tray.

If empty, supply paper.

Your machine may be out of toner.

Check the display for a TONER LOW message.

If displayed, replace the toner cartridge.

Your machine may need a new drum.

Check the display for a REPLACE IMAGE DRUM message.

If displayed, replace the toner cartridge.

Your machine may be set to Answering Mode: Memory Reception Mode.

Change the Answering Mode to Auto Receive Mode [FAX].

See "Setting Basic Features, Setting the Answering Mode."

Your machine doesn't print the Message Confirmation Report or the Message Confirmation Report doesn't print the way you want it to.

There are several options for the Message Confirmation Report. Make sure that these options are set the way you want them to be.

See "Reports, Message Confirmation Report."

Packing Your Machine

United States and Canada

Use this procedure to ship the machine.

- 1 Remove the image drum unit (with toner cartridge).
- 2 Place the image drum unit (with toner cartridge still installed) into a polyethylene plastic bag (black) and store it in a cool place away from direct sunlight.
- 3 Package the machine.

! **Warning:** *DO NOT ship the machine with the image drum unit installed.*

Specifications

All specifications are subject to change without notice.
For the latest product and technical support information,
visit the Konica Web site:

<http://www.Konicabt.com>

Dialing

One-Touch

80

Auto Dials

150

Groups

20, up to 230 numbers each

Broadcast Transmissions

240 locations

General

Protocol

ITU-T G3

Modem Speed

Maximum 33.6 Kbps

Transmission Speed

2.5 seconds per page (ITU-T Test Chart #1)

Print Speed

Maximum 10 pages per minute

Print Resolution

600 dpi

Communication Method

Half duplex

Coding Scheme

MH / MR / MMR / JBIG with ITU-T ECM error correction

Memory

Standard

12.5 MB

Optional

! *Only one memory slot is available in your machine.*

• *Therefore, only one of the available memory options may be installed at a time.*

You must have the 8 MB expansion card to utilize the 600 dpi TX feature.

Capacity

All page numbers given are APPROXIMATES.

Your results may vary, depending on the nature of your pages.

2 MB

Capacity:

160 pages of Option 2 MB memory

360 pages of Standard 4 MB memory

520 pages total

4 MB

Capacity:

320 pages of Option 4 MB memory

360 pages of Standard 4 MB memory

680 pages total

8 MB

This item is called the 600 dpi TX Kit.

Capacity:

640 pages of Option 4 MB memory

360 pages of Standard 4 MB memory

1,000 pages total

Scanning

Scan Speed

1.5 seconds per page

Scan Resolution

300 dpi

Scan Width

8.5 inches (21.5 centimeters)

Scan Length

5 to 14 inches (12.8 to 35.6 centimeters)

Gray Scale

64 levels

Consumables

Toner Yield

The number of pages you can print with one toner cartridge depends on the type of documents you usually receive or copy.

A toner cartridge will print about 2,500 pages/letter size of standard business communications at a typical print coverage of 4% (equivalent of CCITT No. 1 test chart).

The first toner cartridge installed in a new image drum unit will have a decreased yield because the image drum unit has to be filled.

Drum Yield

The life of an image drum depends on a number of factors, including temperature and humidity, the type of paper you use, and the number of pages per job.

The image drum cartridge should last approximately

- 20,000 pages for continuous printing
- 14,000 pages at 3 pages per job
- 9,000 pages at 1 page per job

Paper Handling

Automatic Document Feeder

Letter, A4

50 sheets of 13 to 20-lb. paper (49 to 75 g/m²)

30 sheets 21 to 28-lb. paper (79 to 105.5 g/m²)

Single sheet of 32-lb paper (121 g/m²)

Universal Tray

Letter, legal 13 inch, legal 14 inch, Executive, A4, A5, A6.

250 sheets maximum

16 to 24 lb. (60 to 91 g/m²)

Manual Feeder

Single Sheet

Letter, legal 13 inch, legal 14 inch, Executive, A4, A5,
A6, JIS B5

16 to 32 lb. (60 to 121 g/m²)

Envelopes

Monarch, COM-10, DL, C5, COM-9

! *You must use envelopes with a straight-cut flap.*

Physical

Dimensions

! *The paper tray is NOT included in any measurements.*

Width

14.2 inches (36 centimeters)

Depth

18.6 inches (47.2 centimeters)

Height

13.8 inches (35.2 centimeters)

Weight

Includes image drum

30.9 pounds (14 kilograms)

Electrical

Power

120 VAC +6%, -15%

50/60 Hz +/- 2%

or

220/240 VAC +/- 15%

50/50 Hz +/- 2%

Battery Backup

72 hours

Power Modes

Ready

Energy Saving

Standby

Warmup Time

From Standby, 30 seconds

Environmental

Temperature

Operating

50 to 90 degrees Fahrenheit

10 to 32 degrees Celsius

Storage

14 to 110 degrees Fahrenheit

-10 to 43 degrees Celsius

Humidity

Operating

20 to 80% Relative Humidity, non-condensing

Storage

10 to 90% Relative Humidity, non-condensing

Index

Symbols

- 0000 Code on Reports 167, 168
- 2-digit Speed Dial
 - Sending a Fax 80
 - Speed Dial/Search Key 22
- 3-digit Speed Dial
 - Sending a Fax 80
 - Speed Dial/Search Key 22
- 600 dpi TX Kit (Option)
 - 187, 188, 189, 211

A

- Access Digit (PBX) 55
- Accessories 186
- Active Memory Files Report 89, 163
- Activity Report 162
- Address, Personal Mailbox 116

Alarms

- Adjusting the Buzzer 59
- Adjusting the Speaker Volume 59
- Alarm Indicator Location 20
- Continuous Tone 58, 184
- Incoming Ring 57
- Signal Tones 26
- Stop Key 23

Alphanumeric

- Caps Key 25
- Programming the Keys 24
- Telephone Directory 12

ALT# (Speed Dial Number) 66

Alternate Number 12, 24

Answering Machine

- and Telephone, Install 38
- Installation 38
- Remote Receive 51
- Telephone Answering Device Mode [TAD] 51

Answering Mode

- Answering Machines 38
 - Auto Receive Mode [FAX] 50
 - Automatic Mode Detection 13
 - Forwarding Mode [FWD] 52
 - Manual Receive Mode [TEL] 51
 - Memory Reception Mode [MEM] 52
 - PC Fax Mode [PC] 52
 - Setting 50
 - Telephone Answering Device Mode [TAD] 51
 - Telephone/Fax Mode [T/F] 51
- ## Auto Dial
- Number of 209
 - Relay Broadcast Report Confirmation (#99) 130
- Auto Receive Mode [FAX] 50
- Auto Start 54
- Automatic Document Feeder 12
- Automatic page re-transmission 13
- Automatic redial 13

B

- B.C. (Communication Code) 171
- Back Cover 17
- Batch, Delayed Transmission 110
- Battery Backup 12
 - Specifications 214
- Broadcast
 - Confirmation Report 164
 - Definition 99, 105
 - Enter Key 21
 - Entry Report 169
 - Locations (Number of) 209
 - Sending 105
 - vs. Group 98
- Busy
 - BUSY (Result Code) 170
 - Busy Signal
 - Redial Interval 54
 - Redial Tries 54
 - Busy Tone 55
- Buzzer, Adjusting the Volume 59

C

- Call Forwarding 123, 124
- Cancel
 - CANCL (Result Code) 170
 - Clear Key 21
 - Delayed Transmissions 109
 - Faxes Polled into Memory 146
 - Messages Stored in Memory 90
 - Stop Key 23
- Capitalization, Caps Key 25
- Chain Dial 25, 74
 - Creating a Chain Dial Number 74
 - Dialing a Chain Dial Number 74
 - Number 25
 - Plus Key 25
- Characters
 - Caps Key 25
 - Unique Key 21
- Cleaning
 - Cleaning Page 190
 - Scanner Path 172
- Clear
 - Clear Key Location 21
 - Document Jams 191
 - Printing Paper Jams 192
- Clock Adjustment 45, 48
- Closed Network 13, 82
 - Problem Solving 206
 - Setting 82
 - Unsolicited Faxes 13
- CNG Count 154
- Codes
 - Communication 171
 - Result 170
- Coding Scheme 210
- Communication
 - Communication Codes 171
 - Communication Error 203
 - Communication Method 210
 - Errors 26
- COMP. (Result Code) 170
- Computer
 - PC Fax Mode [PC, optional] 52

- Confidential
 - Confidential Reception Report 122
 - Deleting Faxes 123
 - Faxes 115
 - Knowing when you've received a confidential fax 122
 - Mailboxes 13
 - Printing Faxes 122
 - Receiving Faxes 121
 - Requirements 121
 - Reception 13
 - Reception Report 169
 - Remote Mailbox Information 120
 - Requirements 115
 - Sending Faxes 120
- Configuration Report 165
 - Changing Functions 149
 - Current Settings 148
 - Printing 148, 149
- Confirming Results 85
- Consumables
 - Image Drum 187
 - Handling 29
 - Replacement 177
 - Resetting the Counter 179
 - Yield 177, 212
 - Obtaining Replacements 186
 - One-Touch Label 23, 187
 - Toner Cartridge 187
 - Handling 29
 - Replacement 173
 - Yield 173, 212
- Continuous Tone 58, 184
- Contrast
 - Resolution Key 21
 - Set while Loading Documents 79
- Control Access to Your Machine 5
- Control Panel 12, 15, 19
 - Alarm Indicator 20
 - Enter Key 21
 - No response when keys are pressed 201
 - Shift Down Key 20
 - Shift Left Key 20
 - Shift Right Key 20
 - Shift Up Key 20
- Copy 13
 - Copy Output Lever 16
 - Copy Stacker 16
 - Copy Stacker Extension 16
 - Copy Stacker Release Buttons 15
 - Dual Access 92
 - Face Up or Face Down 97
 - Copy Output Lever 16
 - Making Copies 95
 - Start/Copy Key 22
- Counters 200
 - Accessing 200
 - Image Drum, Resetting 200
 - Resetting the Image Drum Counter 179
- Country
 - Overseas Communications
 - Echo Protection 67
 - PBX assistance 60
 - Pulse Dial Rate 153
 - Pulse Dial Type 153
 - Pulse Make Ratio 153
 - Setting the Language 59
- COVER (Result Code) 170
- Current Settings
 - Configuration Report 148
- Customer Support 6

D

- Date, Setting 48
- Del Key 24
- Delayed
 - Definition 107
 - Delayed Batch
 - Canceling 113
 - Destination Number 110
 - Sending 110, 112
 - Setting the Time 111
 - Speed Dials 31 - 40 107, 110
 - Delayed Fax vs. Delayed Batch 107
 - Delayed Transmission 4, 107
 - Canceling 109
 - Number of Sessions 107
 - Sending 108
- Delete
 - Deleting Characters (DEL Key) 24
 - Deleting Confidential Faxes 123
 - Groups 102

Dial

- Broadcast Transmissions 209
- Chain Dial 74
- Communication Speed 67
- Dial Options 46
- Dial Parameter Settings 53
 - Factory Defaults 54
 - Programming 53
- Dial Prefix 56
 - Clearing the Number 61
 - Entering the Number 61
- Dial Pulse (DP) 55
- Dial Tone
 - Detection 54
 - Hook Key 22
- Dialing Characteristics
 - Space Key 25
- Echo Protection 67
- Enter Number before Loading
 - Document 93
- Long Numbers (more than 40 digits) 74
 - Creating 74
 - Dialing 74
- Machine won't dial 202
- Number of Auto Dials 209
- Number of One-Touch Keys 209
- One-Touch Keys 24
- Pauses 25
- Pulse Dial Rate 153

- Pulse Dial Type 153
- Pulse Make Ratio 153
- Real-Time 85
- Redial 85
- Specifications 209
- Variations by Country
 - FLASH/EARTH/NORMAL 56
 - Variations by Country (MF) 55
- Dimensions 213
- Display
 - Blank Display 201
 - Display Messages
 - Normal Display 196
 - Transmission 84
 - Display Panel 12
 - Location 14, 20
 - Display Panel Messages 196
- Distinctive Ring 155
- Incoming Ring 57
- Restrictions 155
- Setting 155

Document

- Document Guides 15
 - Document Jam 191
 - Document Stacker
 - Installation 36
 - Location 15
 - Document Tray
 - Extension 16
 - Location 16
 - Guidelines 76
 - Loading 78
 - Multiple Page 77
 - Single Page 77
- DP (Dial Pulse) 55
- Drum
 - Yield 212
- Dual Access 13, 78, 92
 - While Copying 92
 - While Receiving a Fax 94
 - While Sending a Fax 93
- Dual Line 180
 - Basic Operations 181
 - Benefits 180
 - Definition 180
 - Displays and Reports 184
 - Second Line
 - Connecting 184
 - Option Line Type 185
 - Unpacking 183

E

- EARTH 56
- ECM Function 152
- Electrical
 - Specifications 214
 - Battery Backup 214
 - Power 214
 - Power Modes 214
 - Warmup Time 214
- Emergency
 - Contact Information ii
 - Toner Emergency First Aid ii
- End of Session Tone 26
- English
 - Change the Language 59
- Enter Key 21
- Envelopes 213
 - Straight Cut Flap 213
- Environmental
 - Specifications 214
 - Humidity 214
 - Temperature 214
- Error
 - Err. Report (MCF) 168
 - Error Correction Code 210
 - Error Correction Mode (ECM) 152
 - Error Messages 196
 - Error Tone 26

Exposure

- Image Drum to Light 29
- External Telephone
 - Machine answers first 206

F

- Face Down
 - Copy Output Lever 16
 - Placing Documents 93, 94
 - Stacking 97
- Face Up
 - Copy Output Lever 16
 - Stacking 97
- Factory Defaults
 - Dial Parameter Settings 54
- Faxing
 - Document Guidelines 76
 - General 76
 - Forwarding 13
 - Group vs. Broadcast 98
 - Loading Documents 78
 - Multiple Page 77
 - Receiving Confidential Faxes 121
 - Sending a Delayed Batch 112
 - Sending a Delayed Fax 108
 - Sending Confidential Faxes 120
 - Sending to a Group 103
 - Single Page Specifications 77
 - to Multiple Locations 98

FCC

Sender ID 49

TSI/CSI 49

Features 12

Feeder (Document Tray) Polling 140

First Aid ii

FLASH 56

Forwarding

Call Forwarding 124

Clearing 125

FWD Mode 52

Paper Error 126

Paper Error Limitations 126

Set a Forwarding Number 124

Set Paper/Toner Error Number
126

Setting the Auto Answer Mode
125

Toner Error 126

Toner Error Limitations 126

French

Change the Language 59

Setting the Language 48

Functions

Function List 21, 166

Primary 41

Selecting 40

FWD Mode 52

G

Gray Scale 212

Group

Creating 101

Definition 99

Deleting 102

Dialing 12

Directory 165

Finding by Name 103

Group Directory Report 103

Names

Speed Dial/Search Key 22

Numeric Keypad 22

Sending a fax 103

Specifications 100

Speed Dial / Search 104

vs. Broadcast 98

H

Half Duplex 210

Half-tone 12

Resolution Key 21

Handset

Installation 37

Manual Reception 86

Help 1, 2, 21

Function List 2, 42

Help List 2, 21

Help Button 12, 212

Helpful Hints 7

Checking Information During

Transmissions 8

Quick Message Confirmation
Report 8

Recording Addresses and Pass-
words 10

References 9

Configuration Report 9

Group Directory 9

Help and Function Lists 9

Telephone Directory 9

Send a Fax and Save the Number
7

Hook Key 22

Hub (Relay Key Station) 127

Humidity, Specifications 214

Hyphen Key 22

I

ID

- Deleting Characters 24
- ID/Password Programming 45
- Space Key 25

Identification

- Sender ID 49
- Sender ID on Transmitted Fax 152
- TSI/CSI 49

IEEE-1284 Parallel Port 17

Image

- Gray Scale 212
- Image Contrast
 - Resolution Key 21
- Image in Message Confirmation Report (MCF) 168
- Legal-to-Letter Reduction 39
- Light Print 205
- Received Faxes Distorted 206
- Received Image Quality Poor 204
- Received image very poor 204
- Vertical Streaks 205

Image Drum 18

- Exposure to Light 29
- Protective Sheet 33
- Replacement 177
- Resetting the Drum Counter
 - 179, 200
- Yield 177

Incoming

- Call Parameter Settings 53
 - Call Parameters 57
 - Incoming Ring 57
 - Programming Call Parameter Setting 53
 - Speed Access Options 46
- ### Installation 27
- Contents List 31
 - Document Stacker 36
 - Hints 28
 - Location 30
 - Safety 28
 - Setting up the machine 32
 - Toner Cartridge 34
 - Unpacking 31
- ### Instant Dial 151

J

Jams 202

- Document 191
- Printing Paper 192

JetSuite Pro

- PC Fax Mode [PC, optional] 52

Junk Faxes 13, 82, 206

- Closed Network 82

K

Key Select Tone 26

- L**
 - Label, One-Touch 23
 - LAN Options 47
 - Language
 - Change 59
 - Setting 48
 - LCD Panel. See Display Panel
 - LED Printhead 18
 - Legal
 - Legal to Letter reduction 39
 - Setting the Paper Size 60
 - Tray Extension 39
 - Length, Scanning 212
 - Letter
 - Legal to Letter reduction 39
 - Setting the Paper Size 60
 - LINE Jack
 - Connecting 36
 - Loading Documents
 - Dual Access 78
 - Resolution 79
 - Setting the Contrast 79
 - Setting the Resolution 79
 - Type of Original 79
 - LOC# (Speed Dial Number) 66
 - Location Name (ID)
 - Entering Spaces 25
 - Entering Symbols 21
 - Find 22
 - Loudness
 - Adjusting the Buzzer 59
 - Adjusting the Volume 59
 - Lowercase, Caps Key 25
- M**
 - Machine
 - Dimensions 213
 - Setting the Machine ID 49
 - Speed Access Settings 45
 - Maintenance 172
 - Image Drum
 - Location 18
 - Replacement 177
 - LED Printhead
 - Location 18
 - Toner Cartridge
 - Location 18
 - Replacement 173
 - Manual
 - Dial with Hook Key 22
 - Paper Feeder
 - Location 15
 - Using 96
 - Receive Mode [TEL] 51
 - Reception 86
 - Start/Copy Key 22
 - Stop Key 23
 - Transmission
 - Start/Copy Key 22
 - Stop Key 23

- MCF. *See also* Message Confirmation Report
 - Multi-Location 168
 - Report Options 168
 - Single-Location 168
- MEM Mode 52
- Memory 12
 - Available Memory 89
 - Battery Backup 12, 91
 - Memory Backup
 - Power Failures 83
 - Memory Full Save 151
 - Memory Messages
 - Erasing without Printing 90
 - Limitations 89
 - Power Loss 91
 - Power Outage Report 91
 - Printing 88, 90
 - Switch to Auto Receive Mode 90
 - Memory Password 156
 - Cancelling 156
 - Setting 156
 - Memory Polling 141
 - Memory Polling (Bulletin) 142
- Memory Reception 13, 88
 - [MEM] 52
 - No Paper Reception 87
 - No Toner Reception 87
- Memory Transmission 13
- No paper reception 13
- Specifications 211
 - and 600 dpi TX 211
 - Installation Limitations 211
 - Optional 211
 - Standard 211
- Menu
 - Help Key 42
 - Menu/Exit Key
 - Location 21
 - Navigating 41
 - Primary Functions 41
 - Setting the Paper Size 60
 - Structure 40
- Message Confirmation Report 21, 167
 - Automatic Print when Error Occurs 168
 - Confirming Results 85
 - Doesn't print or doesn't print correctly 207
 - Enter Key 21
 - Image on Report 168
 - Options 168
 - Printing 160
- MF 55
- MFP Option
 - PC Fax Mode [PC, optional] 52
- Modem Speed 210
- Modes
 - Auto Receive Mode [FAX] 50
 - Forwarding Mode [FWD] 52
 - Manual Receive Mode [TEL] 51
 - Memory Reception Mode [MEM] 52
 - PC Fax Mode [PC, optional] 52
 - Remote Receive 57
 - Telephone Answering Device Mode [TAD] 51
 - Telephone/Fax Mode [T/F] 51
- Monitor Volume
 - Adjusting Loudness 59
- Multi-frequency Dialing 55

N

- Navigating
 - Keys 40
 - Menu 41
- Network
 - LAN Options 47
 - Printing
 - Face Up or Face Down 16
- NO (Result Code) 170
- No paper reception 13
- NORMAL 56
- Normal Operation
 - Start/Copy Key 22
- Norwegian Characters
 - Unique Key 21, 24, 68, 69
- Numeric Keypad 14, 22
 - Sending a Fax 81

O

- Off-Hook (Alarm Tone) 26
- OK (Result Code) 171
- One-Touch
 - Dialing 24
 - Keypad 14, 23, 24
 - Label Location 23
 - Labels 23
 - Latch 23
 - Number of 209
 - Programming 24
 - Searching 24
 - Second Panel 26
 - Sending a Fax 80
 - Speed Dial/Search Key 22
- Operation and Maintenance
 - Safety 29
- Operation Functions 150
 - Changing 149
 - CNG Count 154
 - Distinctive Ring 155
 - ECM Function 152
 - Instant Dial 151
 - Memory Full Save 151
 - Memory Password 156
 - Pulse Dial Rate 153
 - Pulse Dial Type 153
 - Pulse Make Ratio 153
 - Remote Diagnosis 150
 - Restrict Access 152
 - Restricted Access ID 157
 - Ring Response 154
 - Sender ID Switch 152
 - T/F Timer Prg. 154
 - Transmission (TX) Mode Default 150
- Option Line Type, Dual Line (Second Line) 185
- Options 186
 - 600 dpi TX Kit 187

- Answering Machine and Telephone, Install 38
- Answering Machine, Install 38
- External Telephone, Install 37
- Handset 37, 187
- Memory Expansion 187
- MFP Kit 187
- Obtaining 186
- Second Paper Tray 187
- Original Documents. See Document Stacker: Location
- Out of paper 13
- Outside Line
 - Dial Prefix (PBX) 56
 - Clearing 61
 - Entering 61
 - PBX 55
 - Connecting to 60

P

- Packing 208
 - Materials used 31
- Paper
 - Automatic Document Feeder 213
 - Capacity 13
 - Changing Sizes 39
 - Clearing Document Jams 191
 - Clearing Printing Paper Jams 192

- Documents
 - General Guidelines 76
 - Multiple Page 77
 - Single Page 77
- Factory Default Size 39
- Legal to Letter Reduction 39
- Length Adjustment Guide 39
- Loading Documents 78
- Loading into the Paper Tray 39
- Manual Feed 96
- No Paper Reception 87
- Paper Indicator 16
- Paper-Size Setting 60
- Print Side 39
- REPLACE PAPER 201
- Setting the Size 60
- Specifications
 - Automatic Document Feeder 213
 - Documents 76, 77
 - Envelopes 213
 - Handling 213
 - Manual Feeder 213
 - Single Sheet 213
 - Universal Tray 213
- Width Guides 39
- Paper Indicator 16
 - Location 16

- Paper Tray
 - Capacity 16
 - Location 16
 - Paper Sizes 16
- Parameters
 - Incoming Calls 57
- Password
 - Changing 118
 - If forgotten 115
 - Memory 156
 - Recording 115
 - Restricted Access ID 157
- Pauses
 - Entering Pauses 25
 - Pause Key 25
- PBX
 - Connecting to 60
 - Machine won't dial out 206
 - PBX Dial Prefix
 - Clearing the Number 61
 - Entering the Number 61
 - PBX Line 55
 - Dial Prefix 56
 - Variations by Country 56
- PC Fax Mode [PC] 52
- PC Mode 52

- PC Print
 - Face Up or Face Down
 - Copy Output Lever 16, 17
- PC/FAX Switch 58
- Personal (Confidential) Mailboxes
 - Closing 119
 - Creating 117
 - Programming 116
- Personal Computer
 - PC/FAX Switch 58
- Personal Mailbox 13
 - Address 116
 - Changing Password 118
 - Number of 116
 - Type 116
- Phone Line, Machine doesn't answer 205
- Photos, Faxing 79
- Physical Dimensions of Machine 213
- Polling 13
 - Machine won't poll 205
 - Reception 145
 - Transmission 137
 - Explanation of Types 138
 - Feeder (Document Tray)
 - Polling 140
 - Memory Polling 141
 - Memory Polling (Bulletin) 142
- Power
 - Power Cord
 - Connecting 38
 - Location 17
 - Power Failures 83
 - Power Outage Battery Backup 12
 - Power Outage Report 83, 169
 - Power Save Mode 22
 - Power Switch 15
- Primary Number 24
- Print
 - Cleaning Page 190
 - Confidential Faxes 122
 - Face Up or Face Down
 - Copy Output Lever 16
 - Faxes Polled into Memory 146
 - Paper Jam 192
 - Print Resolution 210
 - Received faxes won't print 207
 - Reports 160
 - Activity Report 162
 - Message Confirmation Report (MCF) 160
 - Sender ID on Transmitted Fax 152
 - Speed 210
- Priority Transmission 114
- Problem Solving 190
 - Alarm Indicator 20
 - Audible Alarms 26
 - Automatic MCF when Error Occurs 168
 - Checklist 201
 - Closed Network (Rejecting Unsolicited Faxes) 82
 - Communications Speed 67
 - Dial Tone Detection 54
 - Documents Blurry 79
 - Documents too Dark 79
 - Documents too Light 79
 - Echo Protection 67
 - Image Quality
 - Resolution Key 21
 - Type of Original Key 21

- Include Image on MCF 168
- Incoming Ring 57
- Message Confirmation (MCF)
 - Report Options 168
- No Paper Reception 87
- No Toner Reception 87
- PBX Line Access Digit 55
- Power Failures 83
- Power Outage Report 83
- Remote Diagnosis 150
- Report Options 46
- Stop Key 23
- Programming
 - Alphabet Keys 24
 - Alternate Number 24
 - Clear Key 21
 - Creating a Group 101
 - Date 48
 - Deleting Characters 24
 - Dial Parameter Settings 53
 - Enter Key 21
 - Hyphen Key 22
 - Incoming Call Parameter Settings 53
 - Language 48
 - Menu/Exit Key 21
 - Norwegian Characters
 - Unique Key 21, 24, 68, 69
 - One-Touch Keypad 24

- One-Touch Keys 24
- Pauses 25
- PBX Dial Prefix, Clearing 61
- PBX Dial Prefix, Entering 61
- Personal (Confidential) Mailboxes 116
- Primary Number 24
- Sender ID 49
- Setting Machine ID 49
- Setting the Answering Mode 50
- Shift Down Key 20
- Shift Left Key 20
- Shift Right Key 20
- Shift Up Key 20
- Space Key 25
- Special character keys 25
- Speed Dial Numbers 62, 66, 68
 - Collect Information 66
- Stop Key 23
- Symbols
 - Unique Key 21, 24, 68
- Time 48
- Tone Key 21
- TSI/CSI 49
- Unique Key 21
- Programming Functions
 - Deleting Characters 24
- Programming Keys. See Control Panel Keys: Location
- Protective Sheet (for Image Drum) 33

- Protocol
 - Facsimile Protocol 210
- Pulse Dial
 - Pulse Dial Rate 153
 - Pulse Dial Type 153
 - Pulse Make Ratio 153
 - Tone Key 21
- PUNIT (Result Code) 171
- Purchasing Supplies 186

R

- R_JAM (Result Code) 171
- Real-Time Dialing 85
- Receiving
 - Answering Machine 51
 - Confidential Faxes 13
 - Continuous Tone 58, 184
 - Dual Access 94
 - Fax and Telephone Calls 51
 - Faxes are distorted 206
 - Faxes won't print 207
 - Forwarding Mode [FWD] 52
 - Incoming Call Parameters 57
 - Incoming Options 46
 - Incoming Settings 53
 - Manual Reception 86
 - Memory Reception Mode [MEM] 52

- No Paper Reception 87
- No Toner Reception 87
- PC Fax Mode [PC, optional] 52
- Programming Incoming Settings 53
- Remote Receive 57
 - to Memory 88
 - Unit won't receive 205
- Reception Functions 12
- Redial 85
 - Redial Interval 54
 - Redial Key 22
 - Redial Tries 54
- Rejecting Unsolicited Fax Messages 82
 - Closed Network 82
- Relay
 - Relay Broadcast
 - Confirmation Report (Relay Broadcast Report) 130
 - Initiating 132
 - Relay Broadcast Report 131
 - Relay Broadcast Report
 - Auto Dial 99 130
 - Contact Number 130
 - Contact Number Programming 130

- Relay Faxing 4, 127
 - Contact Number (Relay Broadcast Report) 130
 - Destination Groups 134
 - Destination Numbers 134
 - Hub (Key Station) 127
 - Relay Broadcast Report 131, 135
 - Relay Password 134
 - Requirements 127
- Relay Group Numbers 129
- Relay Initiating Station 127
 - Using Your Machine as a 128
- Relay Key Station (Hub) 127, 129
 - Printing the Relay Fax 136
 - Requirements 133
 - Using Your Machine as a 133
- Relay Password 129
- RELOAD DOCUMENT 86
- Remote Diagnosis 150
- Remote Mailboxes
 - Confidential Faxes 120
- Remote Receive 57
 - Answering Machine 51

- Replacement
 - How to Obtain Replacement Parts 186
 - Image Drum 18
 - Toner Cartridge 18
- Reports 13, 160
 - 0000 Code 167, 168
 - Active Memory Files 89, 163
 - Activity Report 162
 - Audible Alarms 26
 - Automatically Generated 161
 - Broadcast Confirmation 164
 - Broadcast Entry Report 169
 - Codes 170
 - Communication Codes 171
 - Result Codes 170
 - Confidential Reception 122, 169
 - Configuration Report 148, 165
 - Function List 166
 - Group Directory Report 103, 165
 - List 161
 - Message Confirmation (MCF) 167
 - Doesn't print or doesn't print correctly 207
 - Image included on report 168
 - Options 168
 - Prints if errors occur 168
 - Power Outage 83, 91, 169
 - Printed from menu 161

- Printing 160
- Relay Broadcast Report 130, 131
 - Program the Number 130
- Report Options 46
- Telephone Directory 12, 164
- Unwanted 204
- Resetting the Drum Counter 179
- Resolution
 - Print 210
 - Resolution Key 21
 - Scanning 212
 - Set while Loading Documents 79
 - Transmission (TX) Mode Default 150
- Restrict Access 152
 - Restricted Access ID 157
 - Cancelling 158
 - Setting 157
 - Using 158
- Result Codes 170
- Ring Response 154
- Ringing, Incoming Ring 57
- RX (Communication Code) 171

S

- S_JAM (Result Code) 171
- Safety
 - Emergency First Aid 30
 - Image Drum Handling 29
 - Installation 28
 - Operation and Maintenance 29
 - Toner
 - Handling 29
 - if swallowed 30
 - in the eyes 30
 - Inhaled Toner 30
- Saving Money 4
 - Control Access to Your Machine 5
 - Passwords 5
 - Restrict Phone Numbers 5
 - Delayed Transmission 4
 - Relay Faxing 4
- Saving Time 6
 - Auto Start 54
 - Dual Access 6
 - Help Button 6
 - Konica Web Site 6
 - Speed Dial Numbers 6
- Scanning 212
 - Cleaning the Scanner Path 172
 - Gray Scale 212
 - Length 212
 - Resolution 212
 - Speed 212
 - Width 212
- Search
 - by Group Name 103
 - Group 104
 - One-Touch Keys 24
 - Search to Send a Fax 81
 - Speed Dial/Search Key 22
- Second Panel
 - Accessing 26
 - Location 23
 - One-Touch Keys 26
- Second Paper Tray
 - Setting the Size 60
- Security 13
 - Closed Network 206
 - Confidential Faxes 115
 - Confidential Mailboxes 13

- Confidential Reception 13
- Personal Mailboxes 13
- Restrict Access 152
- Restricted Access ID 157
- Unsolicited Fax Messages 13
- Sender ID
 - Setting 49
 - Speed Access No. 23 152
 - Unique Key 21
- Sending 80
 - Blank fax received 204
 - Broadcast Fax 105
 - Dial Options 46
 - Document Guidelines 76
 - General 76
 - Loading Documents 78
 - Multi-Location Message Confirmation Report 168
 - Multiple Page Documents 77
 - Poor Quality Received Image 204
 - Relay Faxing 127
 - Single Location Message Confirmation Report 168
 - Single Page Specifications 77
 - to a Single Location 80
- Using a 2-digit Speed Dial 80
- Using a 3-digit Speed Dial 80
- Using a One-Touch 80
- Using an External Telephone 81
- Using the Numeric Keypad 81
- Using the Search Function 81
- Service Function Settings 159
 - MYD/DMY 159
 - Time/Date Print 159
 - TSI Print 159
- Settings, Selecting 40
- Shift Keys
 - Down 20
 - Left 20
 - Right 20
 - Up 20
- Shipping 31, 208
- Signals
 - CNG Count 154
 - Distinctive Ring 155
 - Signal Tones 26
- Size
 - Multiple Page Documents 77
 - Paper 60
 - Single Page Specifications 77
- Sounds
 - Signal Tones 26
- Space Key 25
- Spanish
 - Change the Language 59
 - Setting the Language 48
- Speaker
 - Adjusting the Volume 59
- Special character keys 25
- Specifications 209
 - Coding Scheme 210
 - Communications 210
 - Consumables
 - Drum Yield 212
 - Toner Yield 212
 - Dialing 209
 - Electrical 214
 - Environmental 214
 - Image Drum Yield 177
 - Memory 211
 - and 600 dpi TX 211
 - Installation Limitations 211
 - Optional 211
 - Standard 211
 - Modem Speed 210
 - Paper Handling 213
 - Automatic Document Feeder 213
 - Envelopes 213

- Manual Feeder 213
 - Single Sheets 213
 - Universal Tray 213
 - Physical Dimensions 213
 - Print Resolution 210
 - Print Speed 210
 - Protocol 210
 - Scanning 212
 - Toner Cartridge Yield 173
 - Transmission Speed 210
 - Speed
 - Instant Dial 151
 - Modem 210
 - Print 210
 - Scanning 212
 - Transmission 210
 - Speed Access
 - Dial Options 46
 - ID/Password Programming 45
 - Incoming Options 46
 - LAN Options 47
 - Machine Settings 45
 - Numbers, Types 44
 - Numeric Keypad 22
 - Report Options 46
 - Speed Dial
 - 2-Digit 65
 - 3-Digit 65
 - Alternate Telephone Number 66
 - and Closed Network 82
 - Chain Dialing 74
 - Creating a Chain Dial Number 74
 - Dialing a Chain Dial Number 74
 - Plus Key 25
 - Clearing 73
 - Communication Speed 67
 - Dialing 12
 - Echo Protection 67
 - Group 65, 104
 - Keys don't work 204
 - Name 66
 - Numeric Keypad 22, 68
 - One-Touch
 - Accessing 64
 - One-Touch Keypad 69
 - Primary Telephone Number 66
 - Programming 66, 68, 71
 - Collect Information 66
 - Speed Dial Numbers 62
 - Speed Dial/Search Key 22
 - Types of Speed Dial Numbers 63
 - Stacking
 - Face Up / Face Down 97
 - Standby
 - Menu/Exit Key 21
 - Standby Mode 196
 - Start/Copy Key, Location 22
 - STOP (Result Code) 171
 - Stop Key, Location 23
 - Stopping a Transmission 86
 - Sunlight and Image Drum Exposure 29
 - Supplies 186
 - Symbols
 - Unique Key 21, 24, 68
- ## T
- T/F Mode 51
 - T/F Timer Prg. 154
 - TAD Mode 51
 - Answering Machine 38

- TEL Jack 1 17
- TEL Jack 2 17
- TEL Mode 51
 - Manual Reception 86
 - Unit doesn't switch 206
- Telephone
 - External
 - Installation 37
 - Real-Time Dialing 85
 - Using to Send a Fax 81
 - Telephone Answering Device Mode [TAD] 51
 - Telephone Directory 164
 - Speed Dial/Search Key 22
 - Telephone Line
 - Connection 36
 - Dial Prefix 56
 - Distinctive Ring 155
 - Hook Key 22
 - Line Jack 17
 - PBX 55
 - Poor Conditions (ECM Function) 152
 - TEL Jack 1 17
 - TEL Jack 2 17
 - Variations by Country 56
 - Telephone Number
 - Alternate Number 24, 66
 - Deleting Characters 24
 - Dial Prefix 56
 - Dial Settings 53
 - Forwarding Mode [FWD] 52
 - Numeric Keypad 22
 - Primary Number 24, 66
 - Programming Dial Settings 53
 - Redial Key 22
 - Sender ID 49
 - TSI/CSI 49
 - Telephone/Fax Mode [T/F] 51
 - Telephone and Answering Machine
 - External
 - Installation 38
- Temperature Specifications 214
- Time
 - Setting 48
 - Setting for Delayed Fax 205
- Timing
 - Ring Response 154
 - T/F Timer Prg. 154
- Tone (MF) Duration 55
- Tone Key 21
- Tone/Plus (MF/DP) 55
- Toner

- Cleaning 29
- Emergency First Aid 30
- Handling 29
- In the eyes 30
- Inhaled 30
- Installation 34
- Location 18
- No Toner Reception 87
- Replacement 173
- Swallowed 30
- Toner Low
 - No Toner Reception 87
- Yield 173, 212
- Toner Emergency First Aid 30
- Touch Tone
 - MF 55
- Transmission
 - Delayed 107
 - Batch 110
 - Didn't work 205
 - Fax 107

- Fax vs. Batch 107
- Dial Settings, Programming 53
- Display Messages 84
- Dual Access 93
- Fax forwarding 13
- Functions 12
- Options 46
- Priority Transmission 114
- Speed 210
- Start/Copy Key 22
- Stop Key 23
- Stopping 86
- Transmission (TX) Mode Default 150
- Transmission Rate 12
- Transmit
 - Broadcast Fax 105
 - Group vs. Broadcast 98
- TSI/CSI
 - Hyphen Key 22
 - Numbers 22
 - Setting 49
- TX (Communication Code) 171
- Type of Original Key, Location 21

U

- Umlaut Characters, use Unique Key 24
- Unique
 - Characters 21
 - Unique Key 21, 24
- Unpacking
 - Missing Items 31
- Unsolicited Faxes 82, 206
 - Closed Network 82
- Unwanted Faxes 206
- Uppercase (Caps Key) 25
- User Language, Changing 59

V

Ventilation

Installing the Machine 30

Voice Request

Machine disconnects before it
answers 205

Volume

Buzzer Adjustments 59

Speaker Adjustments 59

W

Warranty

LED Printhead (Location)

Location 18

Width, Scanning 212