

INSTALLATION INSTRUCTIONS - #99-7899

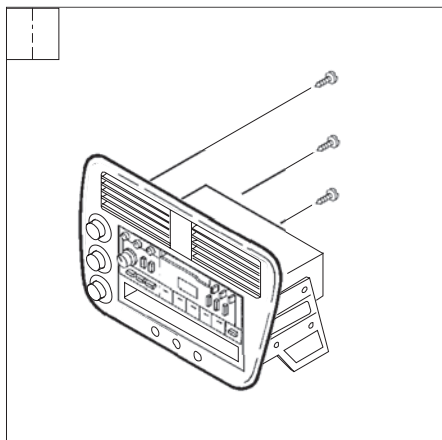

Mount the climate control pod to the back of the dash trim bezel with (3) Phillips screws previously removed in step #2.

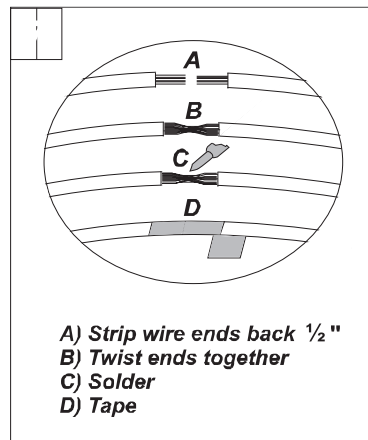

- A) Strip wire ends back 1/2"
- B) Twist ends together
- C) Solder
- D) Tape

Locate the factory wiring harness in the dash. Metra recommends using the proper mating adaptor and making connections as shown. (Isolate and individually tape off the ends of any unused wires to prevent electrical short circuit).

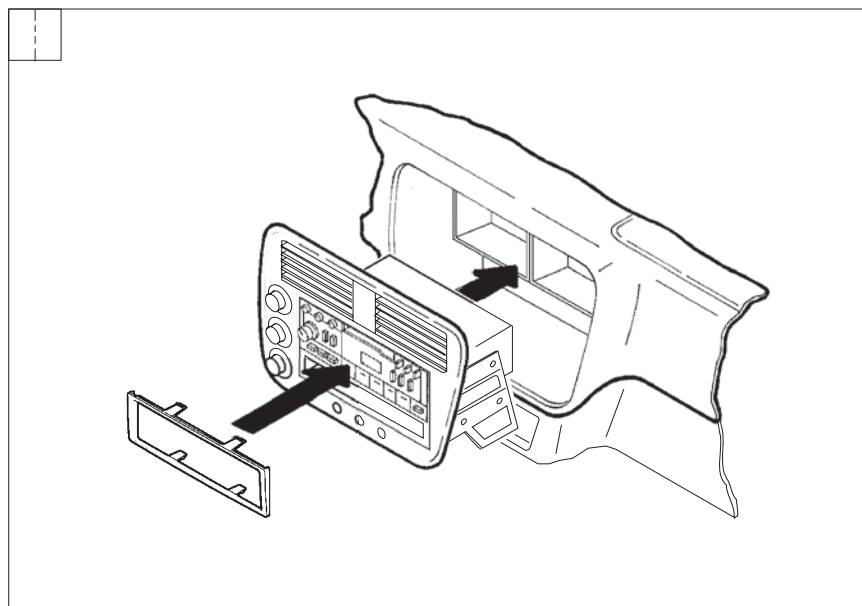

Re-connect the battery terminal and test the unit for proper operation. Snap the *Trimplate* over the mounted head unit. Slide the dash trim bezel assembly into the sub dash until secure.

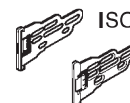
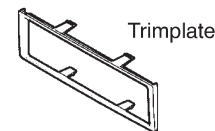
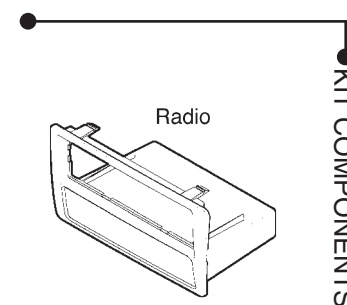

KIT COMPONENTS

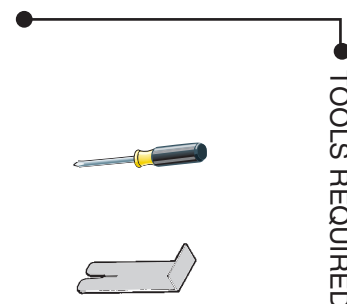

TOOLS REQUIRED

VEHICLE APPLICATIONS

Vehicle Type
HONDA
Civic 2001 - 2005

Page
1 - 3

99-7899

KIT FEATURES

- DIN head unit provision with pocket
- ISO head unit provision with pocket

Questions?

Call the Help Line: (800)253 TECH
Monday - Friday 9:00 am - 7:00 pm EST
Saturday - Sunday 10:00 am - 4:00 pm EST

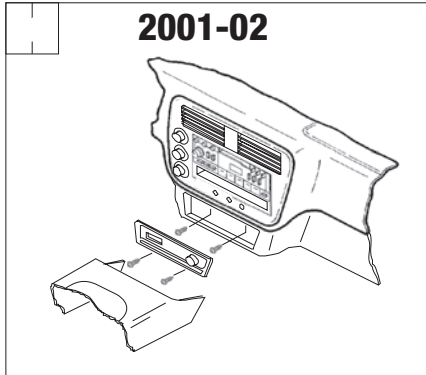

2001-02

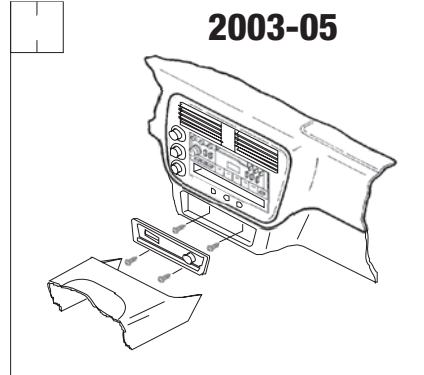

2003-05

Disconnect the negative battery terminal to prevent an accidental short circuit. Unclip the parking brake trim panel and remove (2) Phillips screws exposed (under radio assembly, facing up). Remove (1) plastic clip and (1) Phillips screw from each side of the center console. Slide the center console toward the back of the vehicle to access (2) Phillips screws on the power outlet panel. Unclip the power outlet panel and remove (2) Phillips screws exposed. Unclip the dash trim bezel assembly (including the head unit and climate controls) and remove the assembly.

Unsnap and remove triming from around floor shifter. Unsnap and remove larger trim around floor console shifter. Remove (2) Phillips screws from in-between cupholder and shifter. Unsnap sides of console (2 snaps per side) and remove with power outlet assembly. Remove (2) Phillips screws from under radio assembly, facing up.

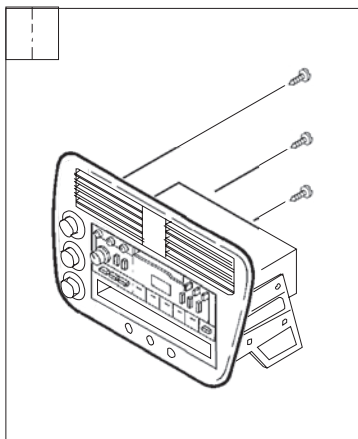

Remove (3) screws securing the climate control pod to the back of the dash trim bezel and remove the pod.

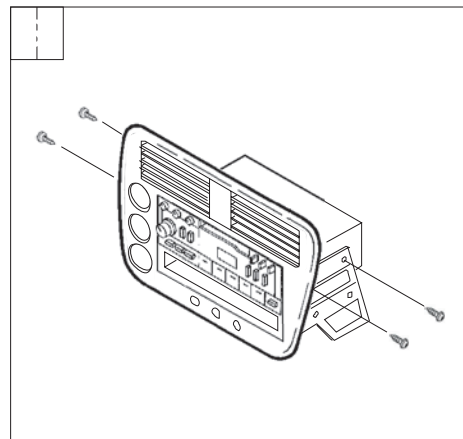

Remove (4) Phillips screws from each side securing the factory head unit to the bracket assembly and remove the unit.

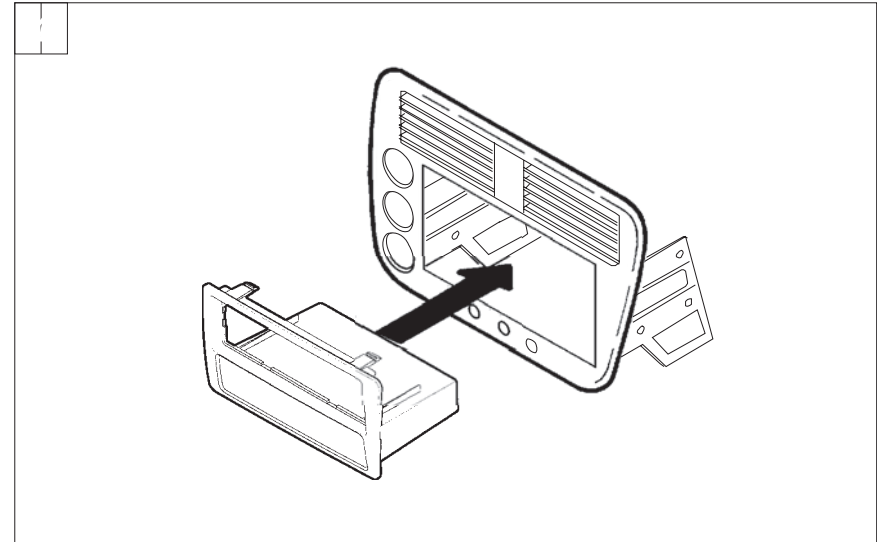

Snap the **Radio Housing** into the sub dash.

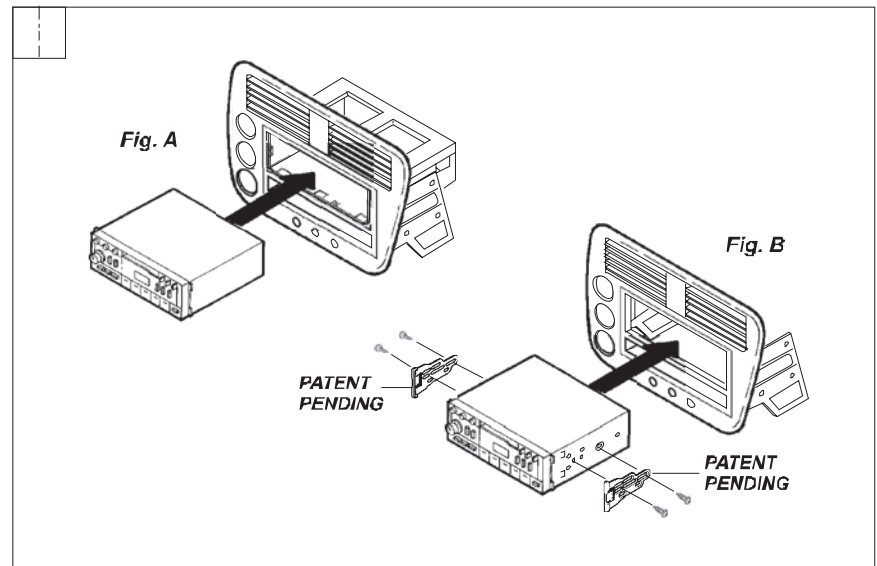

DIN HEAD UNITS: Slide the DIN cage into the **Radio Housing** and secure by bending the metal locking tabs down. Slide the aftermarket head unit into the cage and secure. (see Fig. A)
ISO HEAD UNITS: Align the holes in the **ISO Brackets** with the holes in the head unit and mount the Brackets to the head unit with the screws supplied with the unit. Snap the head unit/bracket assembly into the **Radio Housing**. (see Fig. B).