

## ALL VEHICLES

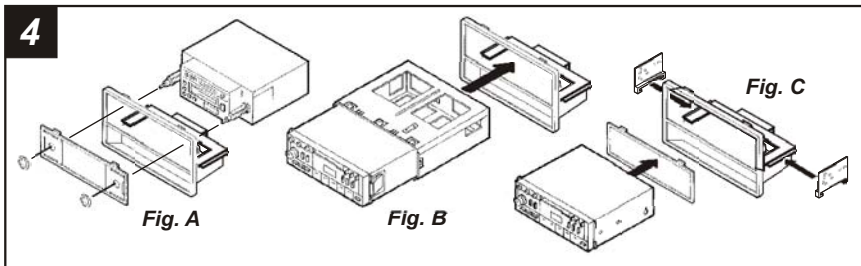

**2-SHAFT HEAD UNITS:** Snap the Faceplate into the **Radio Housing**. Slide the aftermarket head unit into the kit and secure with shaft nuts. (see Fig. A)

**DIN HEAD UNITS:** Slide the DIN cage into the kit and secure by bending the metal locking tabs down. Slide the aftermarket head unit into the cage until secure. (see Fig. B)

**ISO-DIN HEAD UNITS:** Slide the **ISO-DIN Brackets** onto the sides of the **Rear Support Bracket**. Cut and remove the shaft supports from the **Faceplate** and snap into the **Radio Housing**. Slide the aftermarket head unit into the Housing, align the holes in the unit with the holes in the ISO-DIN Brackets and mount with the screws supplied with the unit. (see Fig. C)

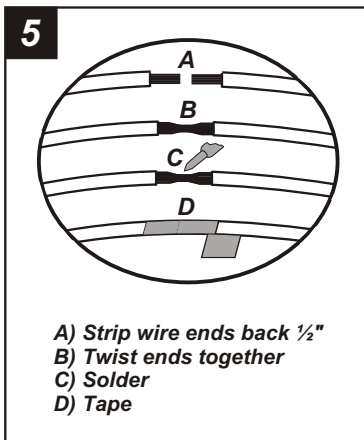

Locate the factory wiring harness in the dash. Metra recommends using the proper mating adaptor and making connections as shown. (Isolate and individually tape off the ends of any unused wires to prevent electrical short circuit).

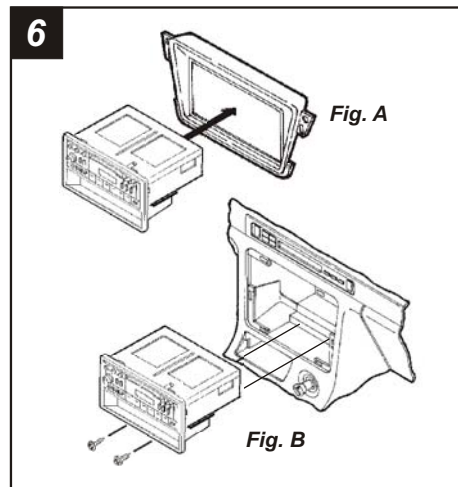

**ACCORD 1990-93, INTEGRA, ODYSSEY, OASIS:** Re-connect the battery terminal and test the unit for proper operation. Snap the head unit/kit assembly into the sub-dash.

**LEGEND, TL, VIGOR:** Re-connect the battery terminal and test the unit for proper operation. Snap the head unit/kit assembly into the factory trim bezel. Mount the bezel to the dash with those screws previously removed in step #1. (see Fig. A)

**ACCORD 1994-97, CL:** Re-connect the battery terminal and test the unit for proper operation. Slide the head unit/kit assembly into the sub-dash and mount the **Rear Support Bracket** to the rear support provision with (2) hex-head bolts previously removed. (see Fig. B)

rev. 250701

### KIT FEATURES

- ▶ Shaft, DIN and ISO-DIN unit provisions
- ▶ Pocket provisions

### KIT COMPONENTS

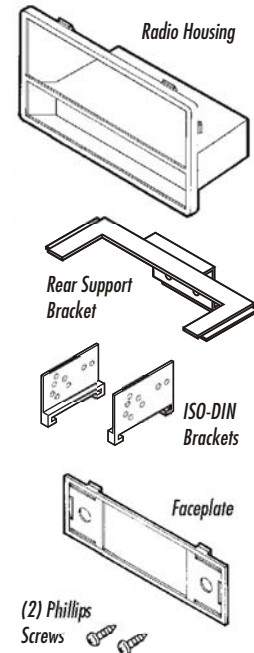

### TOOLS REQUIRED



# 99-7892 INSTALLATION INSTRUCTIONS

## APPLICATIONS

CAR	PAGE
ACURA	
CL 1997-99.....	1
Integra 1990-93.....	2
Integra 1994-00.....	3
Legend 1990.....	4
Legend 1991-96.....	5
TL 1996-98.....	6
Vigor 1992-94.....	7
HONDA	
Accord 1990-93.....	8
Accord 1994-97.....	9
Odyssey 1995-98.....	10
ISUZU	
Oasis 1996-99.....	10

## ACURA CL 1997-99

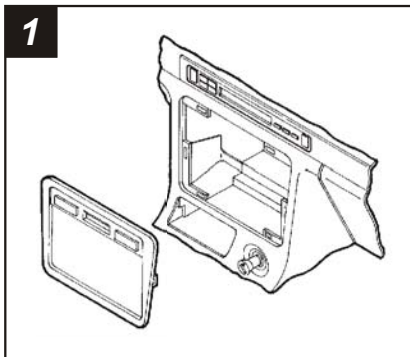

1  
Disconnect the negative battery terminal to prevent an accidental short circuit. Unclip the radio trim bezel and disconnect the clock and climate control wiring. Remove (2) 8mm hex-head screws securing the factory head unit and disconnect the wiring.

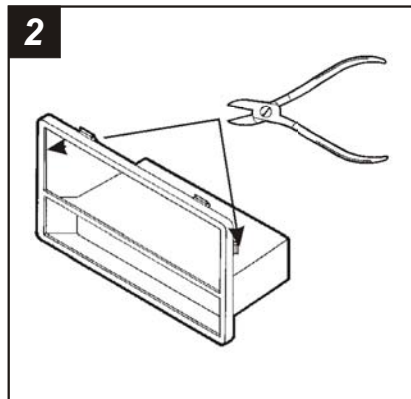

2  
Cut and remove the *SIDE* clips from the **Radio Housing**.

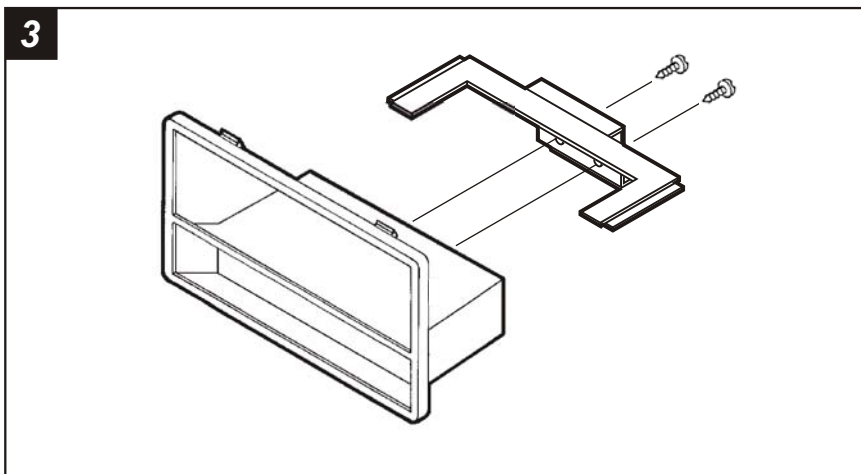

3  
Mount the **Rear Support Bracket** to the back of the pocket with (2) **Phillips Screws** supplied. Skip to the *Installation Instructions for ALL VEHICLES* on Page #11.

## HONDA Odyssey 1995-98 / ISUZU Oasis 1996-99

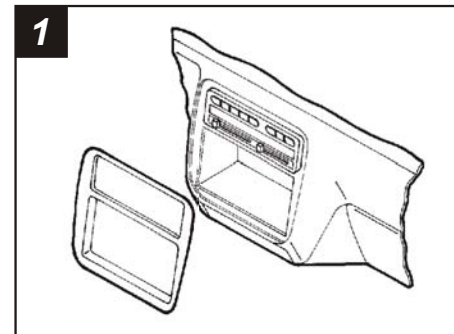

1  
Disconnect the negative battery terminal to prevent an accidental short circuit. Remove (2) 8mm screws under the glove box. Remove (1) Phillips screw on the glove box arm and remove the box. Remove (2) Phillips screws exposed in the glove box cavity. Remove (2) Phillips screws below the storage box door (under the ashtray). Remove (2) screws from the left side of the dash console. Remove (1) Phillips screw from the coin tray. Remove (1) Phillips screw under the ignition. Remove (4) Phillips screws securing the factory cupholder. Remove (2) 8mm hex-head screws from the rear support bracket and disconnect the wiring.

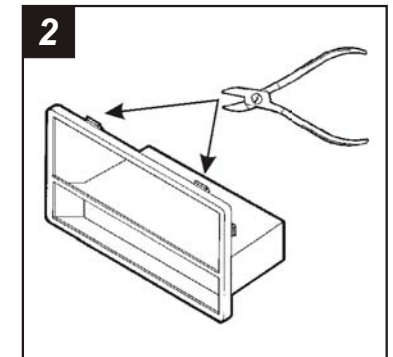

2  
Cut and remove the *TOP* clips from the **Radio Housing**.

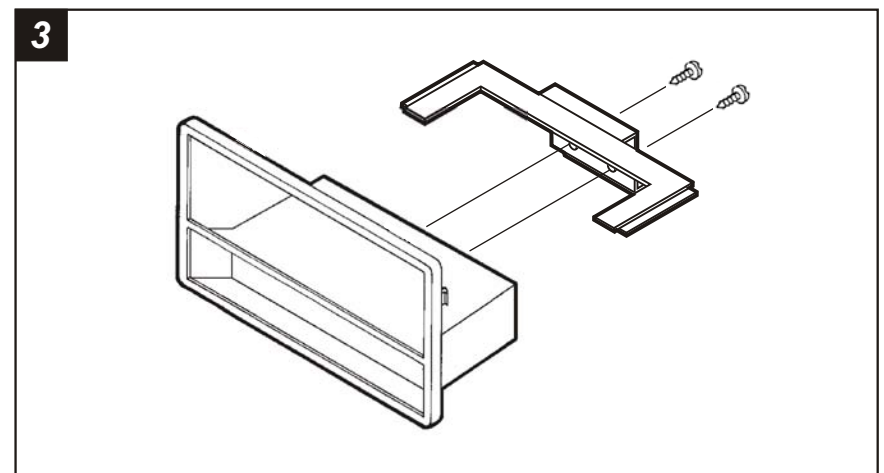

3  
**ISO-DIN HEAD UNITS:** Mount the **Rear Support Bracket** to the back of the pocket with (2) **Phillips Screws** supplied. Skip to the *Installation Instructions for ALL VEHICLES* on Page #11.

## HONDA Accord 1994-97

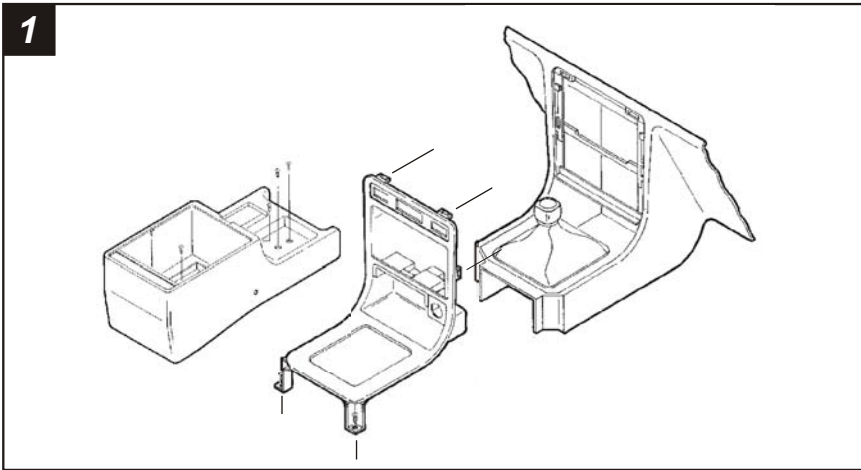

Disconnect the negative battery terminal to prevent an accidental short circuit. Remove the ashtray and (1) ¼" #8 Phillips screw exposed. Open the storage compartment and remove (2) #8 Phillips screws exposed. Remove the cupholder tray and (3) #8 Phillips screws inside. Lift the center console out and remove (2) Phillips screws exposed at the base of the dash trim bezel. Unclip the bezel and remove. Remove (2) hex-head screws securing the factory head unit and disconnect the wiring.

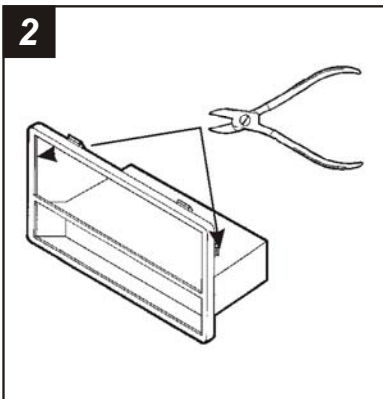

Cut and remove the **SIDE** clips from the **Radio Housing**.

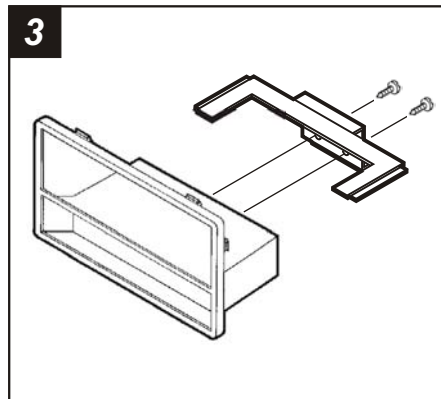

Mount the **Rear Support Bracket** to the back of the pocket with (2) **Phillips Screws** supplied. Skip to the **Installation Instructions for ALL VEHICLES** on Page #11.

## ACURA Integra 1990-93

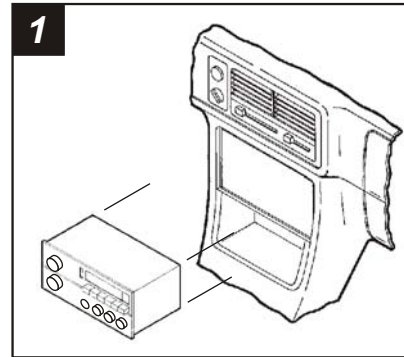

Disconnect the negative battery terminal to prevent an accidental short circuit. Remove (3) screws from each side of the center console and remove the console. Remove (2) screws securing the factory head unit to the sub-dash support bracket. Slide the head unit/pocket assembly out and disconnect the wiring.

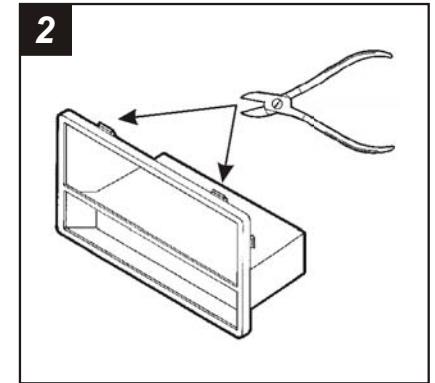

Cut and remove the **TOP** clips from the **Radio Housing**.

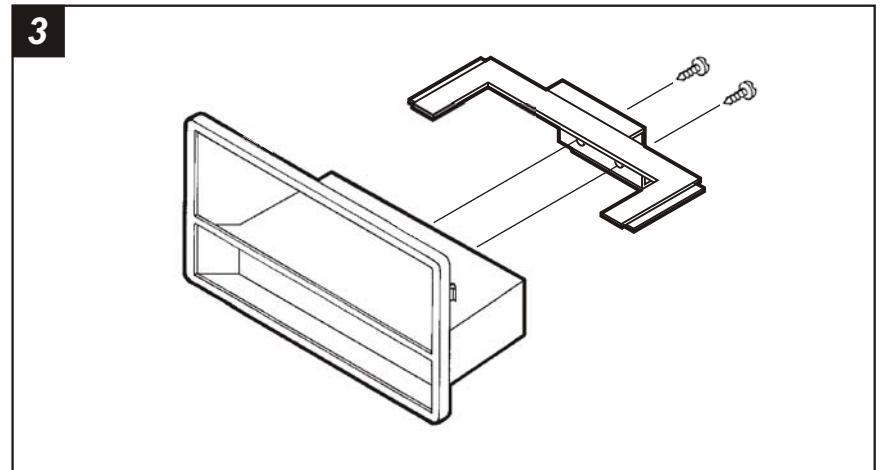

**ISO-DIN HEAD UNITS:** Mount the **Rear Support Bracket** to the back of the pocket with (2) **Phillips Screws** supplied. Skip to the **Installation Instructions for ALL VEHICLES** on Page #11.

## ACURA Integra 1994-00

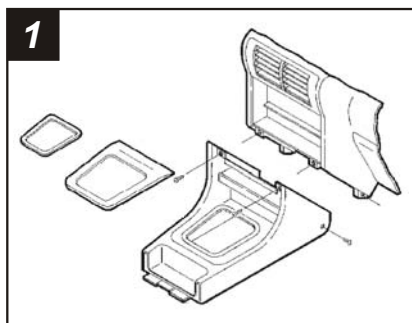

1  
Disconnect the negative battery terminal to prevent an accidental short circuit. Remove the cover cap located under the emergency brake and remove (2) screws exposed. Remove (2) screws from the rear corners of the lower dash trim bezel and remove. Remove the ashtray and (2) screws exposed. Unsnap the ashtray housing and disconnect the cigarette lighter harness. Remove the gear shifter knob and unsnap the shifter trim. Remove (2) screws below the radio opening and remove the upper dash trim bezel. Remove (2) 8mm screws securing the factory head unit and disconnect the wiring.

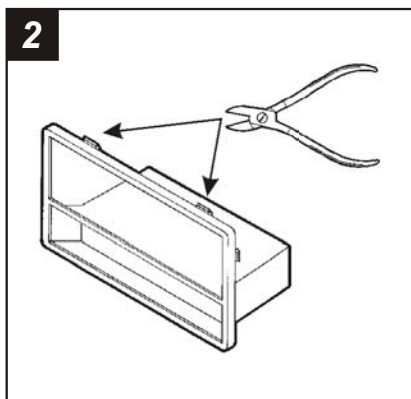

2  
Cut and remove the TOP clips from the **Radio Housing**.

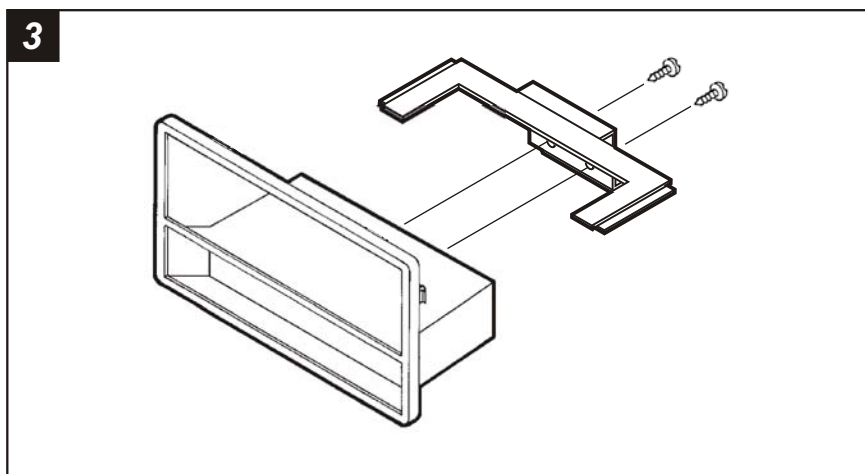

3  
**ISO-DIN HEAD UNITS:** Mount the **Rear Support Bracket** to the back of the pocket with (2) **Phillips Screws** supplied. Skip to the *Installation Instructions for ALL VEHICLES* on Page #11.

## HONDA Accord 1990-93

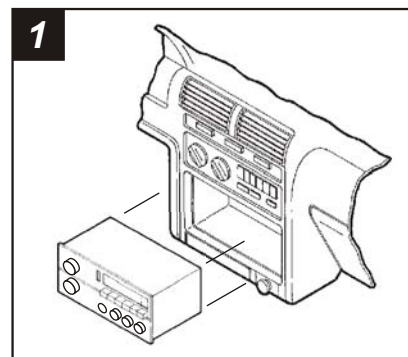

1  
Disconnect the negative battery terminal to prevent an accidental short circuit. Remove (4) screws from the lower portion of the center console. Remove the gear shifter knob and lift the console out. Remove the ashtray and ashtray bracket. Remove (2) screws from the bottom of the head unit support, slide the unit out and disconnect the wiring.

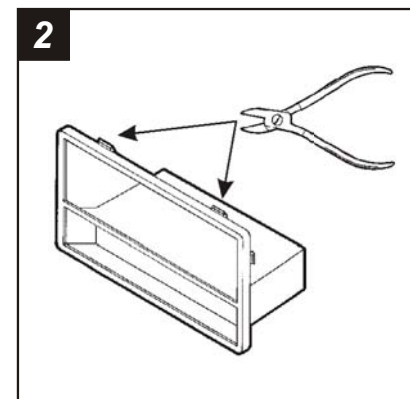

2  
Cut and remove the TOP clips from the **Radio Housing**.

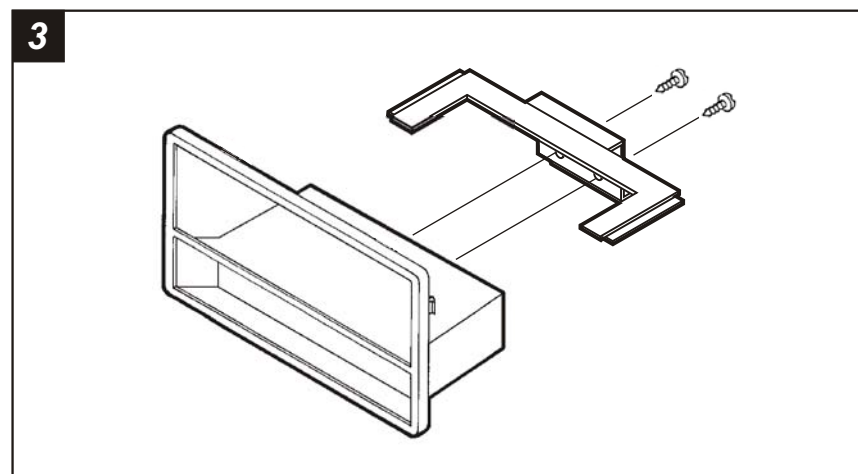

3  
**ISO-DIN HEAD UNITS:** Mount the **Rear Support Bracket** to the back of the pocket with (2) **Phillips Screws** supplied. Skip to the *Installation Instructions for ALL VEHICLES* on Page #11.

## ACURA Vigor 1992-94

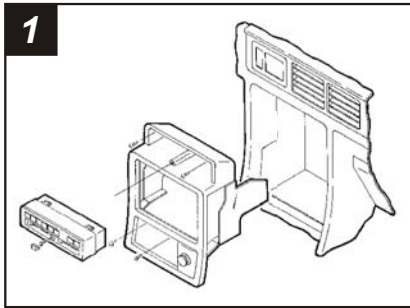

1  
Disconnect the negative battery terminal to prevent an accidental short circuit. Remove the access cap from the climate control cluster and (1) screw exposed. Unclip the cluster and remove (2) screws exposed. Remove the ashtray and (2) Phillips screws exposed. Remove the cover caps from each front corner of the center console and the screws exposed. Open the storage compartment, lift up the carpet and remove (2) screws exposed. Lift up on the center console and remove. Unclip the radio trim bezel and disconnect the wiring. Remove (2) bolts from the back of the factory head unit and disconnect the wiring.

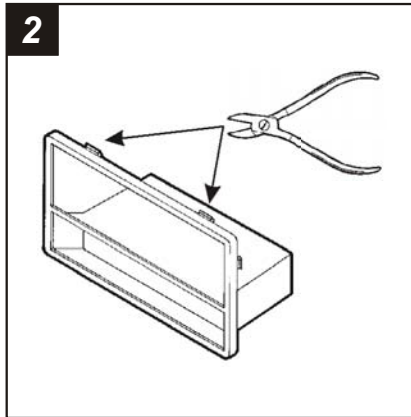

2  
Cut and remove the TOP clips from the **Radio Housing**.

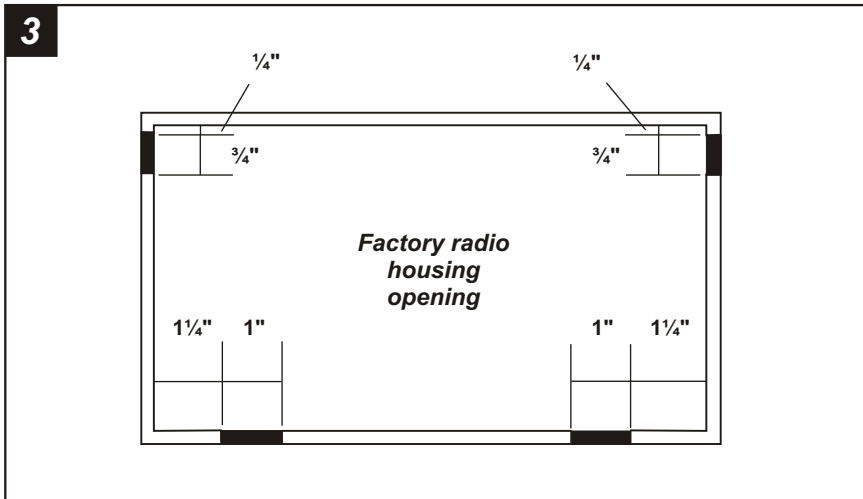

3  
Modify the factory radio housing by trimming the *shaded* portions of the housing lip. Skip to the *Installation Instructions for ALL VEHICLES on Page #11*.

## ACURA Legend 1990

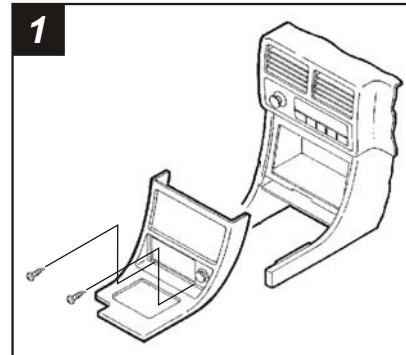

1  
Disconnect the negative battery terminal to prevent an accidental short circuit. Remove (2) screws below the ashtray. Unclip the dash trim bezel. Disconnect the cigarette lighter wiring and remove the bezel. Remove (2) bolts securing the rear of the factory head unit and disconnect the wiring.

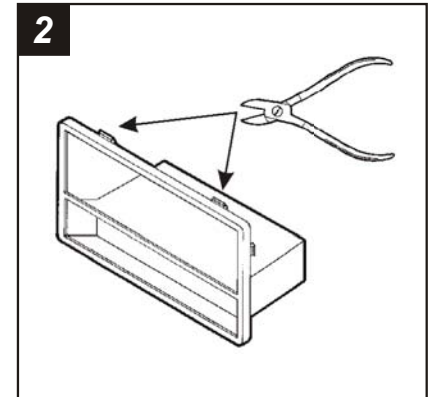

2  
Cut and remove the TOP clips from the **Radio Housing**.

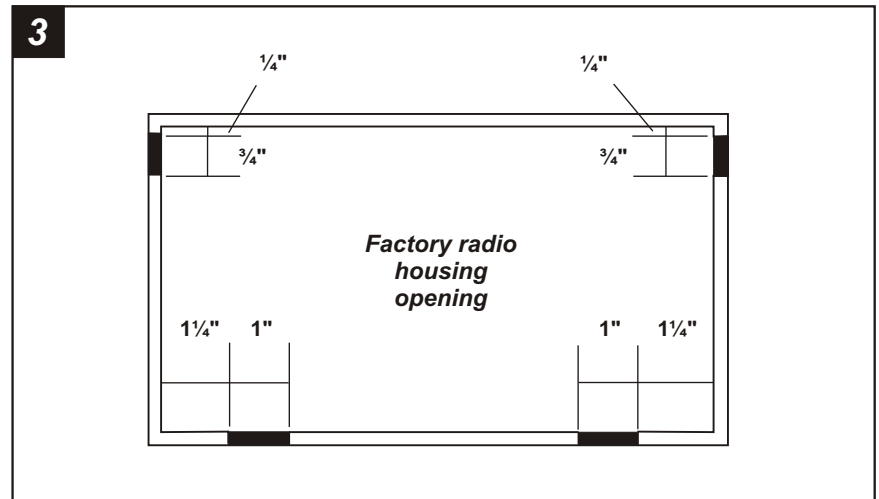

3  
Modify the factory radio housing by trimming the *shaded* portions of the housing lip. Skip to the *Installation Instructions for ALL VEHICLES on Page #11*.



## ACURA Legend 1991-96

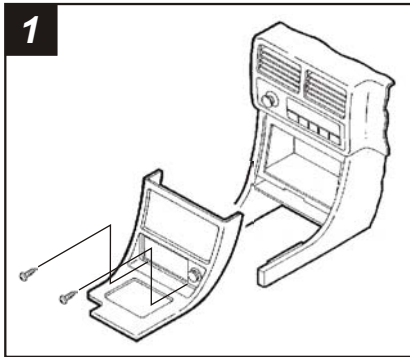

1  
Disconnect the negative battery terminal to prevent an accidental short circuit. Remove (2) screws below the ashtray. Unclip the dash trim bezel. Disconnect the cigarette lighter wiring and remove the bezel. Remove (2) bolts securing the rear of the factory head unit and disconnect the wiring.

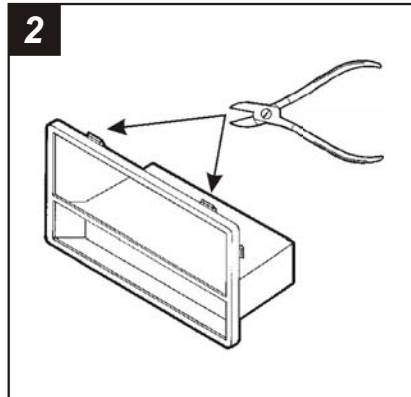

2  
Cut and remove the **TOP** clips from the **Radio Housing**.

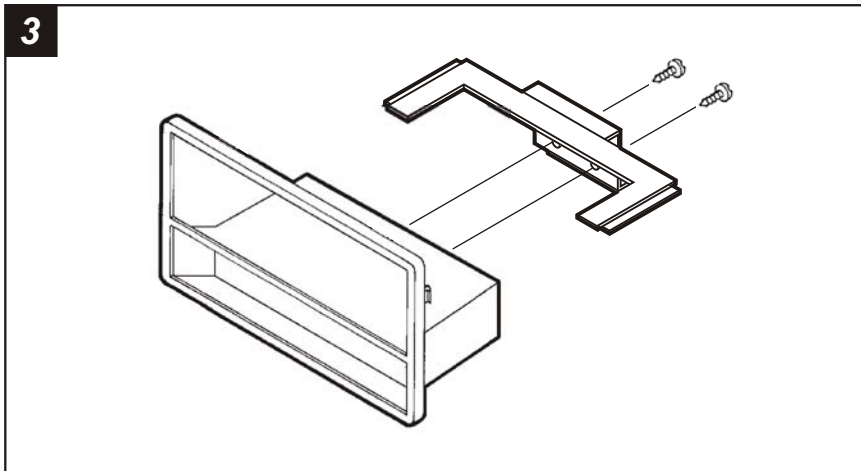

3  
**ISO-DIN HEAD UNITS:** Mount the **Rear Support Bracket** to the back of the pocket with (2) **Phillips Screws** supplied. Skip to the **Installation Instructions for ALL VEHICLES** on Page #11.

## ACURA TL 1996-98

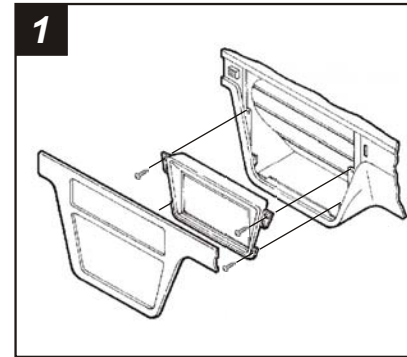

1  
Disconnect the negative battery terminal to prevent an accidental short circuit. Using a small screwdriver, unclip the perimeter of the radio trim bezel. Disconnect the climate control and rear defroster wiring and remove the bezel. Remove (4) Phillips screws securing the factory head unit/trim bezel assembly. Loosen (2) Phillips screws securing the back of the head unit to the metal housing and slide the unit out. (It is NOT necessary to remove the screws securing the metal housing to the bezel). Disconnect the wiring.

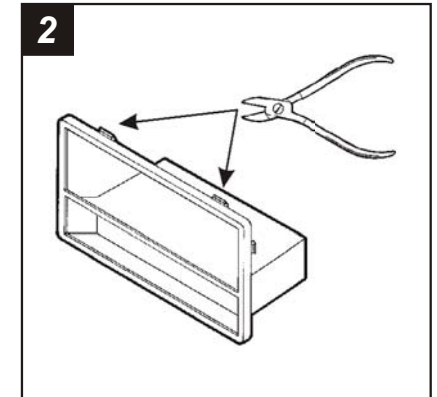

2  
Cut and remove the **TOP** clips from the **Radio Housing**.

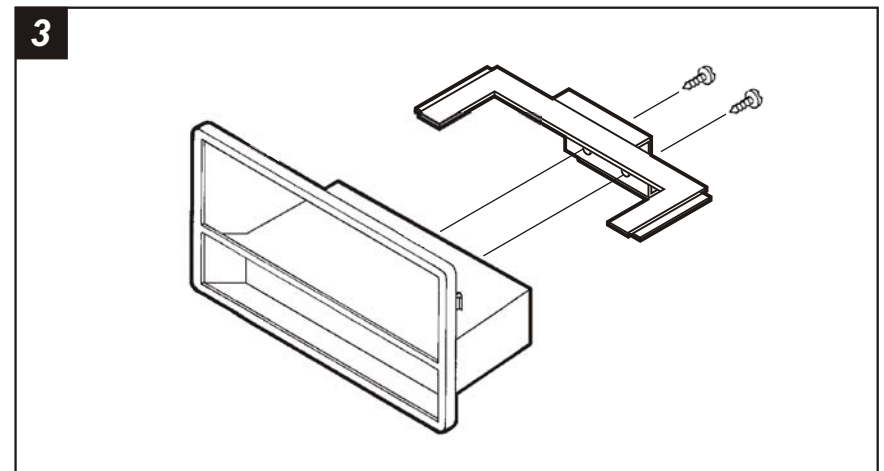

3  
**ISO-DIN HEAD UNITS:** Mount the **Rear Support Bracket** to the back of the pocket with (2) **Phillips Screws** supplied. Skip to the **Installation Instructions for ALL VEHICLES** on Page #11.