



INSTALLATION INSTRUCTIONS FOR PART 99-73355

APPLICATIONS HYUNDAI Veracruz 2007-2010

Automatic climate control only

99-73355

KIT FEATURES

- DIN Radio Provision with Pocket
- ISO Mount Radio Provision with Pocket
- Double DIN Radio Provision
- Stacked ISO Mount Units Provision
- **Painted to match factory dash-"S"=Silver**



KIT COMPONENTS

- A) Radio Housing • B) ISO Brackets • C) ISO Trim Plate • D) Double DIN Brackets
- E) Double DIN Trim Plate • F) Pocket

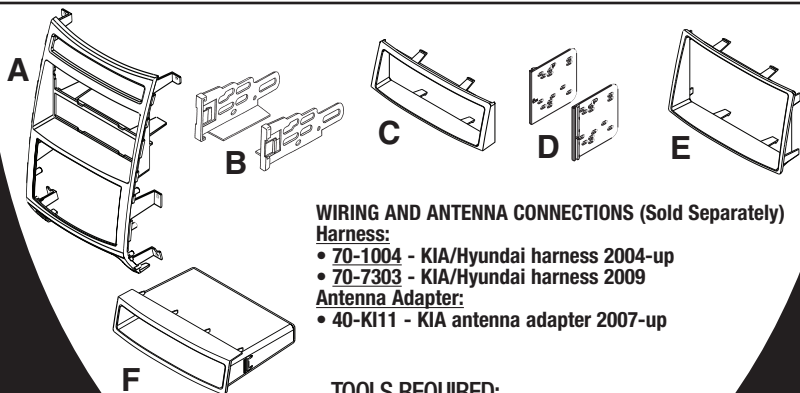

WIRING AND ANTENNA CONNECTIONS (Sold Separately) Harness:

- 70-1004 - KIA/Hyundai harness 2004-up
- 70-7303 - KIA/Hyundai harness 2009

Antenna Adapter:

- 40-K111 - KIA antenna adapter 2007-up

TOOLS REQUIRED:

- Small Flat Blade Screwdriver/ Panel Removal Tool
- Phillips Screwdriver



1-800-221-0932



www.metraonline.com

© COPYRIGHT 2009 METRA ELECTRONICS CORPORATION



TABLE OF CONTENTS

Dash Disassembly

**- Hyundai Veracruz 2007-2010
(Automatic climate control only)1**

Kit Assembly

- Kit Preparation 2
- DIN Mount Radio Provision with Pocket3
- ISO Mount Radio Provision with Pocket..... 4

Note:

Refer also to the instructions included with the aftermarket radio.



KNOWLEDGE IS POWER

Enhance your installation and fabrication skills by enrolling in the most recognized and respected mobile electronics school in our industry. Log onto www.installerinstitute.com or call 800-354-6782 for more information and take steps toward a better tomorrow.

HYUNDAI VERACRUZ 2007-2010

- 1 Disconnect the negative battery terminal to prevent an accidental short circuit.
- 2 Unclip and remove the side trim panels. (Tip: start at the bottom of the panels) (Figure A)
- 3 Remove (6) Phillips head screws securing the radio trim panel and remove trim panel. (Figure B)
- 4 Remove (4) Phillips screws securing the climate control, (2) Phillips screws securing the clock display and (4) Phillips screws securing the pocket from the radio trim panel. (Figure C)

Continue to kit preparation.

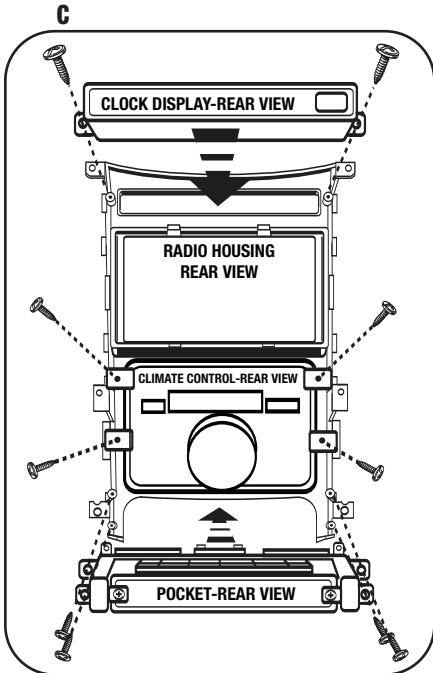
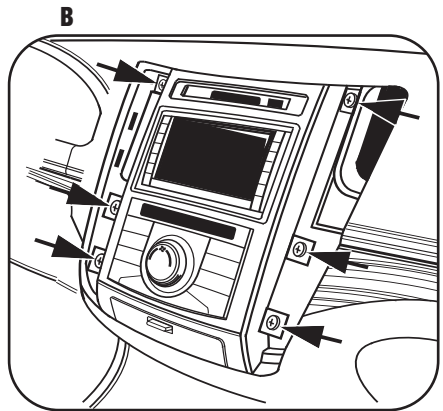
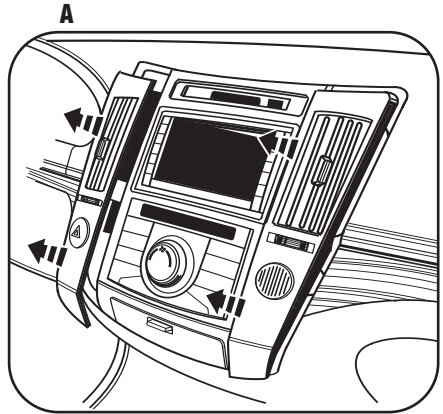

KIT PREPARATION

- 1 Attach the climate control, pocket and the clock display into the 99-7335S radio housing using the factory hardware. (Figure A)

Continue to kit assembly.

A

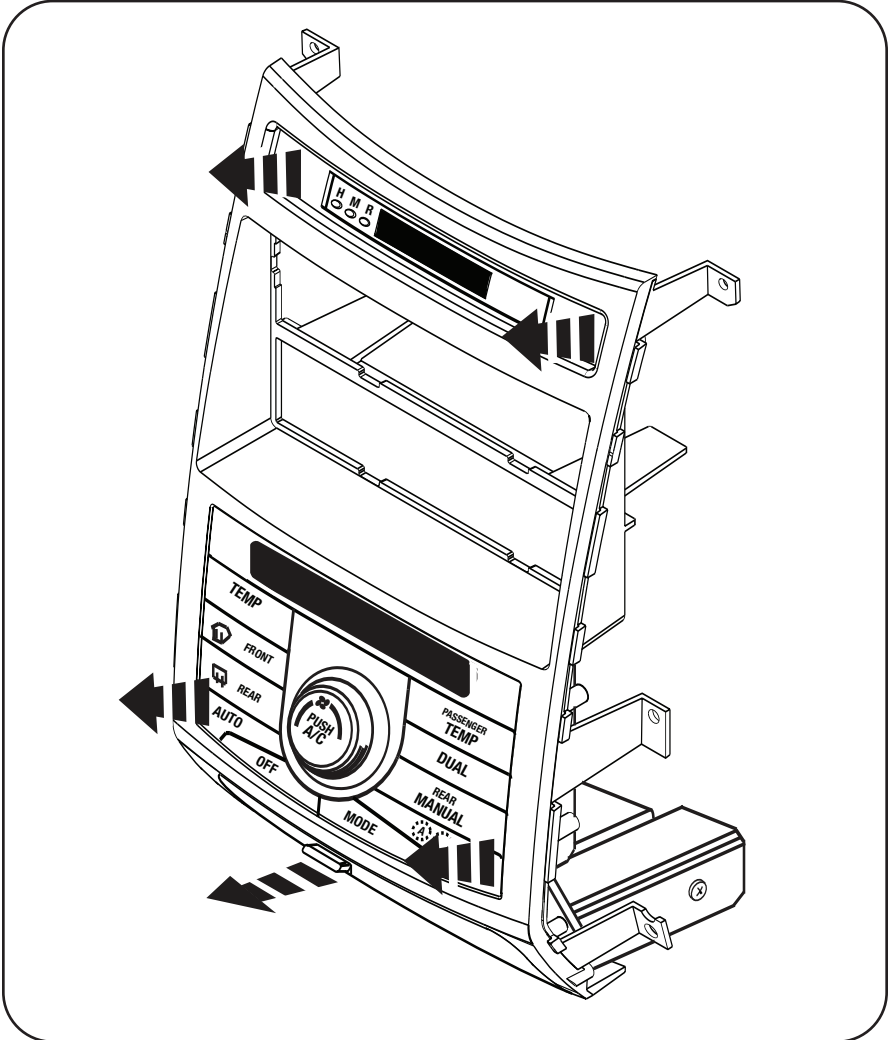

DIN MOUNT RADIO PROVISION WITH POCKET

**Note: Refer also to the instructions included with the aftermarket radio.*

- 1 Locate the factory wiring harness in the dash. Metra recommends using the proper mating adapter from Metra or AXCESS. Re-connect the negative battery terminal and test the unit for proper operation.
- 2 Slide the DIN cage into the Radio Housing and secure by bending the metal locking tabs down. (Figure A)
- 3 Snap the pocket into the bottom opening of the radio housing. (Figure B)
- 4 Slide the aftermarket head unit into the cage and secure. (Figure C)
- 5 Reassemble dash in reverse order of disassembly.

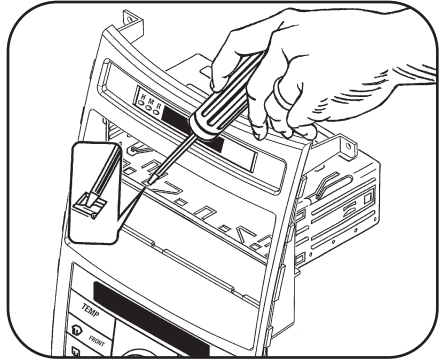
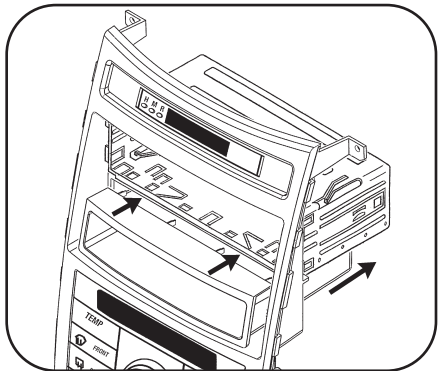
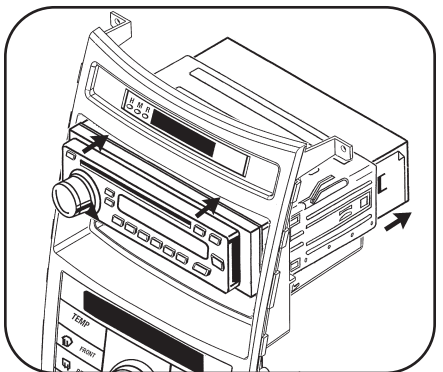
A**B****C**

ISO MOUNT RADIO PROVISION WITH POCKET

**Note: Refer also to the instructions included with the aftermarket radio.*

- 1 Locate the factory wiring harness in the dash. Metra recommends using the proper mating adapter from Metra or AXXESS. Re-connect the negative battery terminal and test the unit for proper operation.
- 2 Mount the ISO Brackets to the head unit with the screws supplied with the unit. (Figure A)
- 3 Snap the pocket into the bottom opening of the radio housing. (Figure B)
- 4 Slide the head unit into the radio opening until the side clips engage. (Figure C)
- 5 Snap the Trim plate into the Radio Housing. (Figure C)
- 6 Reassemble dash in reverse order of disassembly.

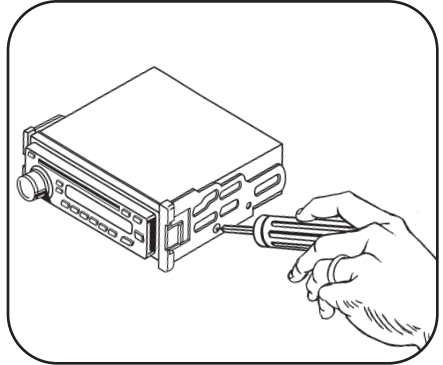
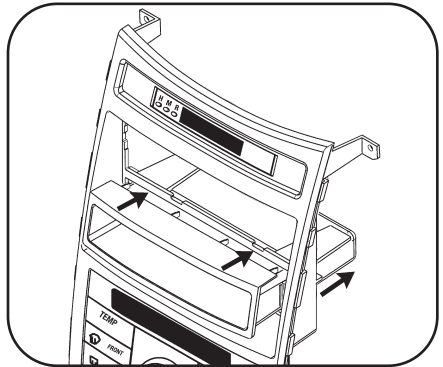
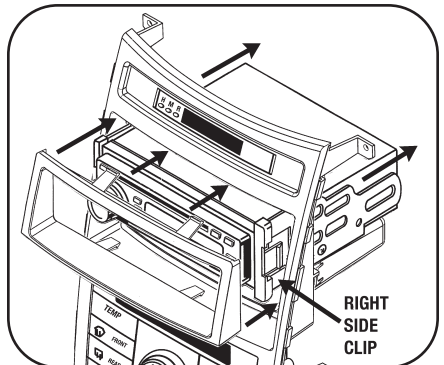
A

B

C

DOUBLE DIN/STACKED ISO MOUNT UNITS RADIO PROVISION

**Note: Refer also to the instructions included with the aftermarket radio.*

- 1 Locate the factory wiring harness in the dash. Metra recommends using the proper mating adapter from Metra or AXXESS. Re-connect the negative battery terminal and test the unit for proper operation.

- 2 Cut and remove the center bar from the radio housing. (Figure A)

- 3 Snap the Double DIN brackets to the inside edge of the Double DIN trim plate. (Figure B)

- 4 Slide the Double DIN head unit or stacked ISO head units into the bracket/radio housing assembly and secure the Double DIN head unit or stacked ISO head units to the assembly using the screws supplied with the radio. (Figure C)

- 5 Snap the Double DIN trim plate into the Radio Housing.

- 6 Reassemble dash in reverse order of disassembly.

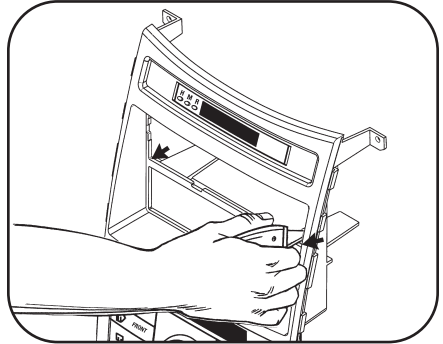
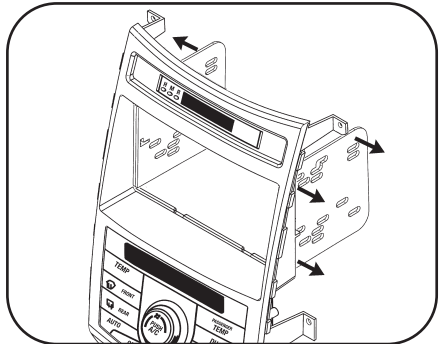
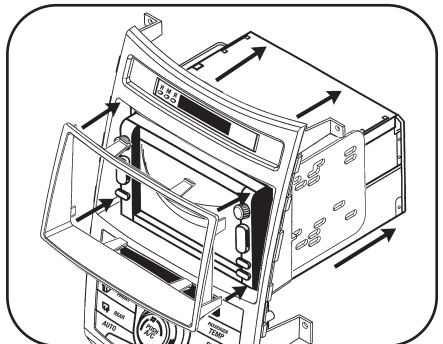
A

B

C

99-73355 INSTRUCTIONS



1-800-221-0932



www.metraonline.com

REV. 09/02/09 © COPYRIGHT 2009 METRA ELECTRONICS CORPORATION INST99-7335S