



## INSTALLATION INSTRUCTIONS FOR PART 99-5819

### APPLICATIONS **FORD** **F-150 (XL Models Only) 2009-10**

# 99-5819



#### KIT FEATURES

- DIN Radio Provision With Pocket
- ISO Mount Radio Provision With Pocket

#### KIT COMPONENTS

- A) Radio Housing
- B) Radio Housing Brackets
- C) ISO Brackets
- D) Trim Plate

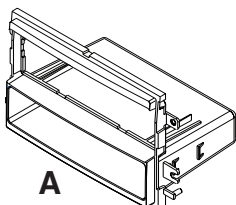

A

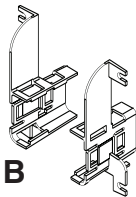

B

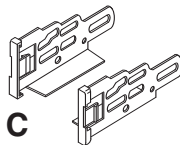

C

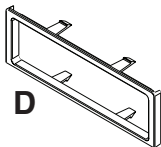

D

#### WIRING AND ANTENNA CONNECTIONS (Sold Separately)

##### Wire harness:

- 70-5520 Ford harness 2003-up

##### Antenna adapter:

- 40-CR10 Chrysler antenna 2002-up

#### TOOLS REQUIRED:

- Cutting Tool
- Phillips Screwdriver
- Socket Wrench

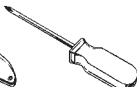

1-800-221-0932



www.metraonline.com

© COPYRIGHT 2010 METRA ELECTRONICS CORPORATION



**TABLE OF CONTENTS**

**Dash Disassembly**

**- FORD F-150 (XL Models Only) 2009-10 .....1**

**Kit Assembly**

**- DIN Radio Provision With Pocket .....2**

**- ISO Mount Radio Provision With Pocket.....3**

**Final Assembly .....4**

**\*Note:**

**Refer also to the instructions included with the aftermarket radio.**

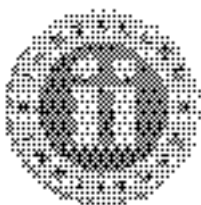

**KNOWLEDGE IS POWER**

Improve your installation and fabrication skills by enrolling in the most recognized and respected mobile electronics school in our industry. Log onto [www.metradeforstate.com](http://www.metradeforstate.com) or call 800-809-8777 for more information and take steps toward a better tomorrow.

## **FORD F-150 (XL Models Only) 2009-10**

- 1 Disconnect the negative battery terminal to prevent an accidental short circuit.
- 2 Unclip and remove the switch panel to the right of the cigarette lighter then remove the (1) 9/32" screw exposed. (Figure A)
- 3 Remove the rubber pad at the top of the radio trim panel then remove the (2) 9/32" screws exposed. (Figure B)
- 4 Unclip and pull the side panels containing the a/c vents away from the radio trim panel. **Note: It is not necessary to remove the panels completely.** (Figure C)
- 5 Unclip and remove the radio trim panel. (Figure D)
- 6 Remove (4) 9/32" screws to remove the factory radio.

*Continue to kit assembly.*

A

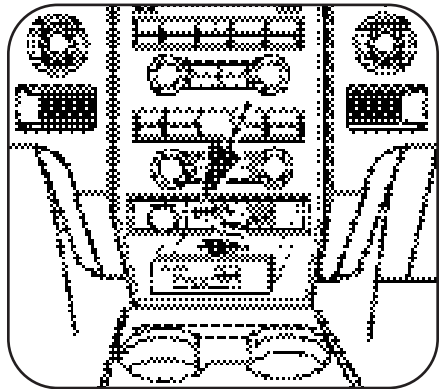

B

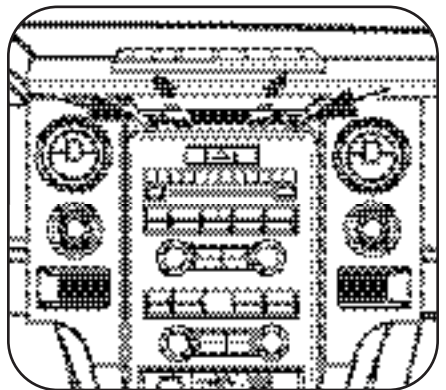

C

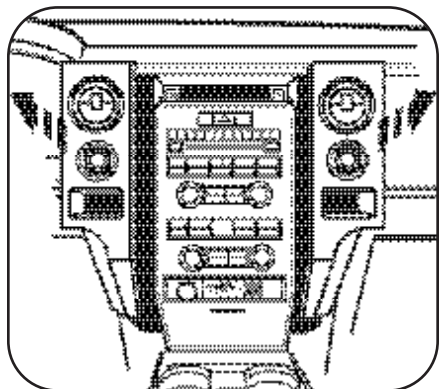

D

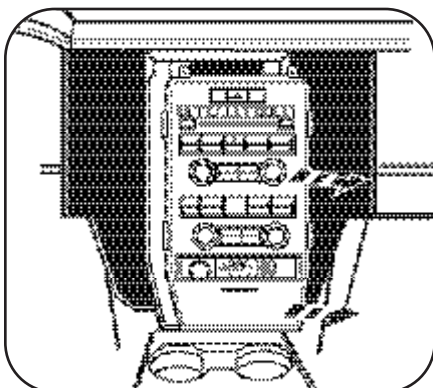

## DIN RADIO PROVISION WITH POCKET

*\*Note: Refer also to the instructions included with the aftermarket radio.*

- 1 Cut and remove the top (2) mounting holes off of the radio housing.

**Note: The notch in the housing should be on top.** (Figure A)

- 2 Slide the included brackets onto the sides of the radio housings pocket from the back of the housing forward. (Figure B)

- 3 Slide the DIN cage into the Radio Housing and secure by bending the metal locking tabs down. (Figure C)

- 4 Slide the aftermarket head unit into the cage and secure. (Figure D)

*Continue to final assembly.*

**A**

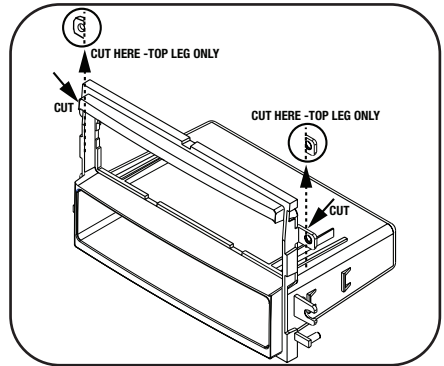

**B**

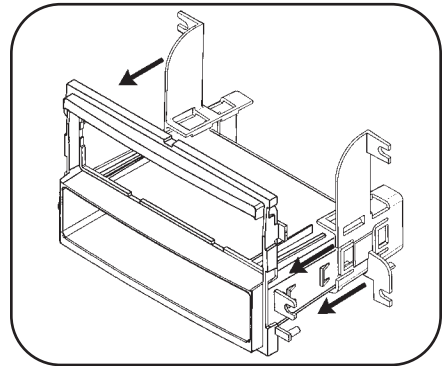

**C**

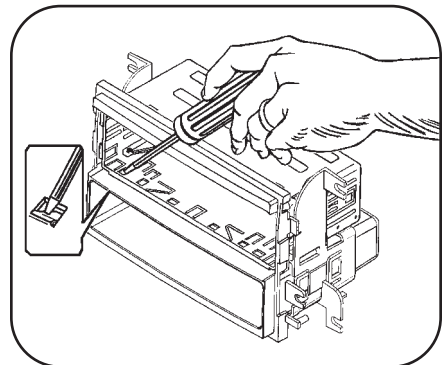

**D**

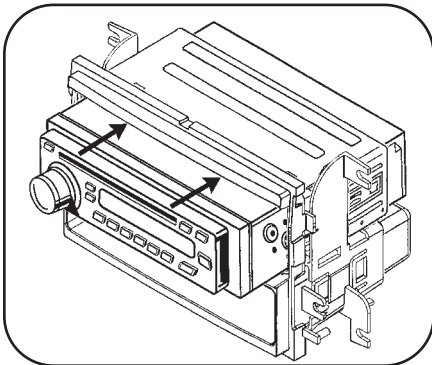

## ISO MOUNT RADIO PROVISION WITH POCKET

*\*Note: Refer also to the instructions included with the aftermarket radio.*

- 1 Cut and remove the top (2) mounting holes off of the radio housing.

**Note:** *The notch in the housing should be on top.* (Figure A)

- 2 Slide the included brackets onto the sides of the radio housings pocket from the back of the housing forward. (Figure B)

- 3 Mount the ISO Brackets to the head unit with the screws supplied with the unit. (Figure C)

- 4 Slide the head unit into the radio opening until the side clips engage. (Figure D)

- 5 Snap the trim plate into the Radio Housing. (Figure D)

*Continue to final assembly.*

**A**

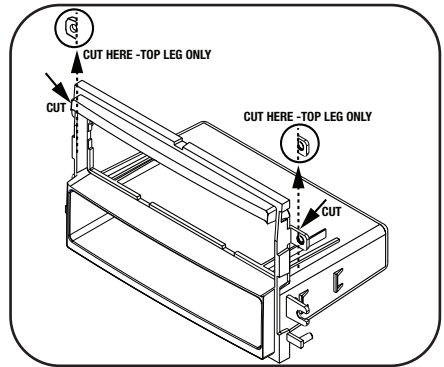

**B**

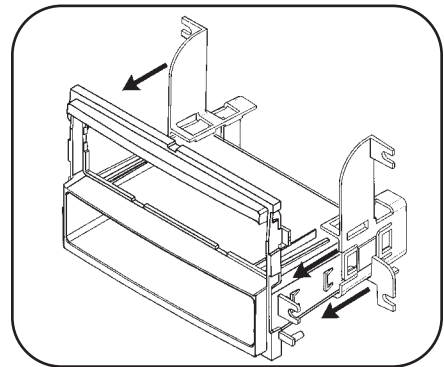

**C**

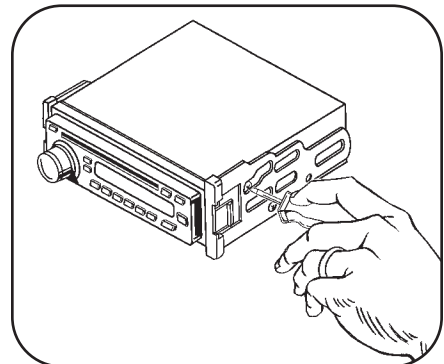

**D**

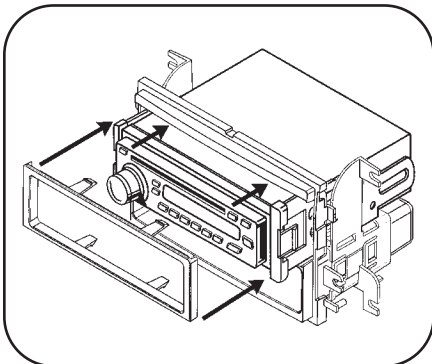

# FINAL ASSEMBLY

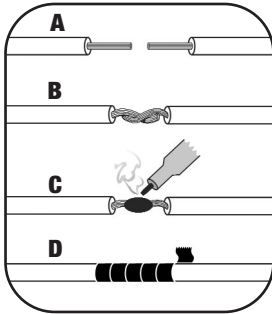

- (A) Strip wire ends back 1/2"**
- B) Twist ends together**
- C) Solder**
- D) Tape**

- 1** Locate the factory wiring harness in the dash. Metra recommends using the proper mating adapter and making the connections as shown. (Isolate and individually tape off the ends of any unused wires to prevent electrical short circuit).
- 2** Re-connect the negative battery terminal and test the unit for proper operation.
- 3** Position the factory bracket/aftermarket radio assembly into the dash and secure using the factory hardware.
- 4** Secure the Double DIN radio housing to the sub dash using the factory hardware.
- 5** Reassemble the rest of the dash in reverse order of disassembly.

## FINAL WIRING CONNECTIONS

Make wiring connections using the EIA color code chart shown below and the instructions included with the head unit. Metra recommends making connections shown below; Strip, Splice, Solder, Tape. Isolate and individually tape off ends of any unused wires to prevent electrical short circuit.

### METRA / EIA WIRING CODE

12V Ignition / Acc. . . . . Red	Right Front (+) . . . . . Gray
12V Batt / Memory . . . . . Yellow	Right Front (-). . . . . Gray/ Black
Ground . . . . . Black*	Left Front (+) . . . . . White
Power Antenna . . . . . Blue	Left Front (-). . . . . White / Black
Amp Turn-On . . . . . Blue / White	Right Rear (+) . . . . . Violet
Amp Ground . . . . . Black / White	Right Rear (-). . . . . Violet / Black
Illumination . . . . . Orange	Left Rear (+) . . . . . Green
Dimmer . . . . . Orange / White	Left Rear (-). . . . . Green / Black

**\*NOTE: When a Black wire is not present, ground radio to vehicle chassis. All colors may not be present on all leads due to manufacturer's specifications.**



# 99-5819 INSTRUCTIONS



**1-800-221-0932**



**[www.metraonline.com](http://www.metraonline.com)**

REV. 04/23/10 © COPYRIGHT 2010 METRA ELECTRONICS CORPORATION INST99-5819